

VEVOR[®]

TOUGH TOOLS, HALF PRICE

Technical Support and E-Warranty Certificate www.vevor.com/support

Candy Vending Machine

We continue to be committed to provide you tools with competitive price.

"Save Half", "Half Price" or any other similar expressions used by us only represents an estimate of savings you might benefit from buying certain tools with us compared to the major top brands and does not necessarily mean to cover all categories of tools offered by us. You are kindly reminded to verify carefully when you are placing an order with us if you are actually saving half in comparison with the top major brands.

VEVOR®

TOUGH TOOLS, HALF PRICE

Candy Vending Machine

MODEL: AK19-08

(RED / YELLOW / BLACK)



MODEL: AK29-11

(BLUE)



NEED HELP? CONTACT US!

Have product questions? Need technical support? Please feel free to contact us:

Technical Support and E-Warranty Certificate
www.vevor.com/support

This is the original instruction, please read all manual instructions carefully before operating. VEVOR reserves a clear interpretation of our user manual. The appearance of the product shall be subject to the product you received. Please forgive us that we won't inform you again if there are any technology or software updates on our product.

PRODUCT PARAMETERS

Product Name:	Candy Vending Machine	
Model:	Ak19-08	ak29-11
Product size:	210x200x430 mm	215x200x410mm
Product Color:	Red / Yellow / Black Three types	Blue
Candy Box:	3PCS	4PCS
Candy capacity:	Approx 8LBS / Candy Box	
Gumball capacity:	Approx 320 of 1" gumballs / Candy Box	
Coin type:	Twenty-five cents	

USE PRECAUTIONS



WARNING:

1. vending machines are designed to work with 0.9-1.3 inch bubble gum/Little twisted egg/single force ball. Capsules or balls of different sizes will not function with this machine.
2. Please use a clean cloth to clean the sugar bin before pouring the candy;
3. Do not pull violently when using it.
4. Please set candies within the parameters described in the specification.
5. Please do not set the product outdoors to avoid rain.

SAVE THESE INSTRUCTIONS

Product introduction

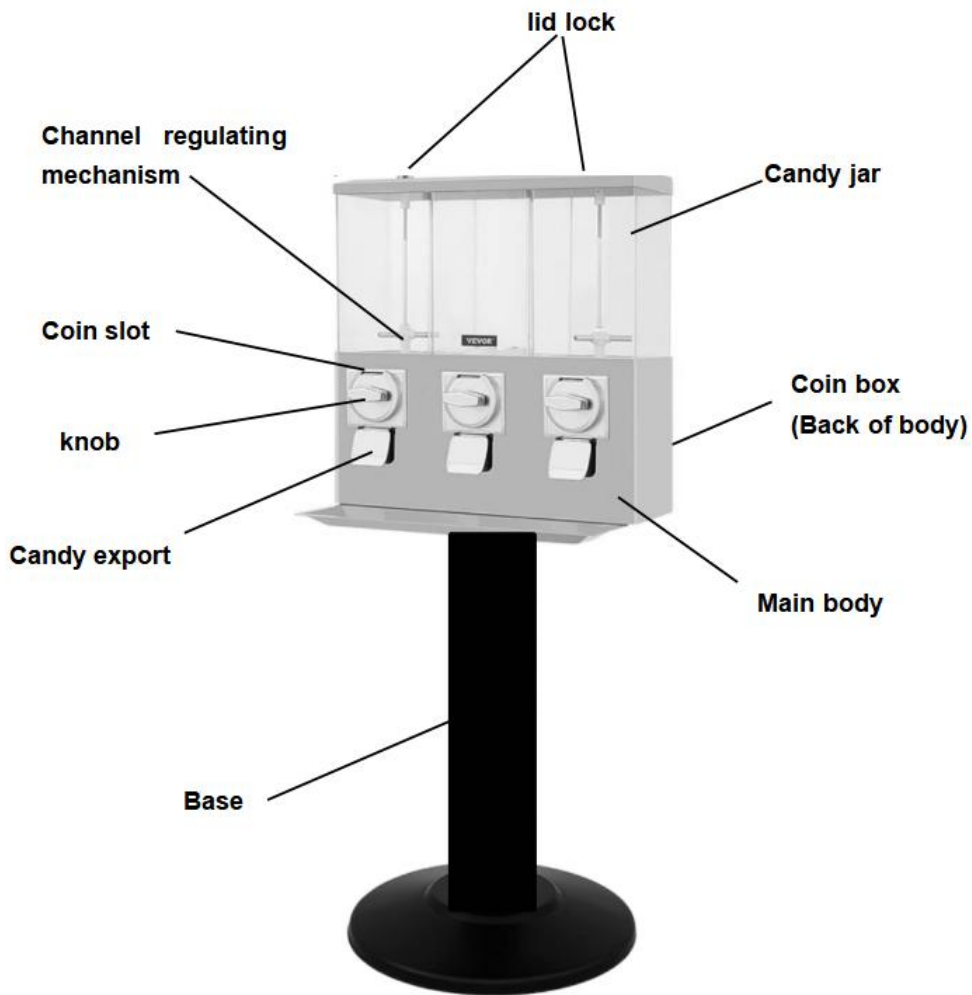

Model:AK19-08

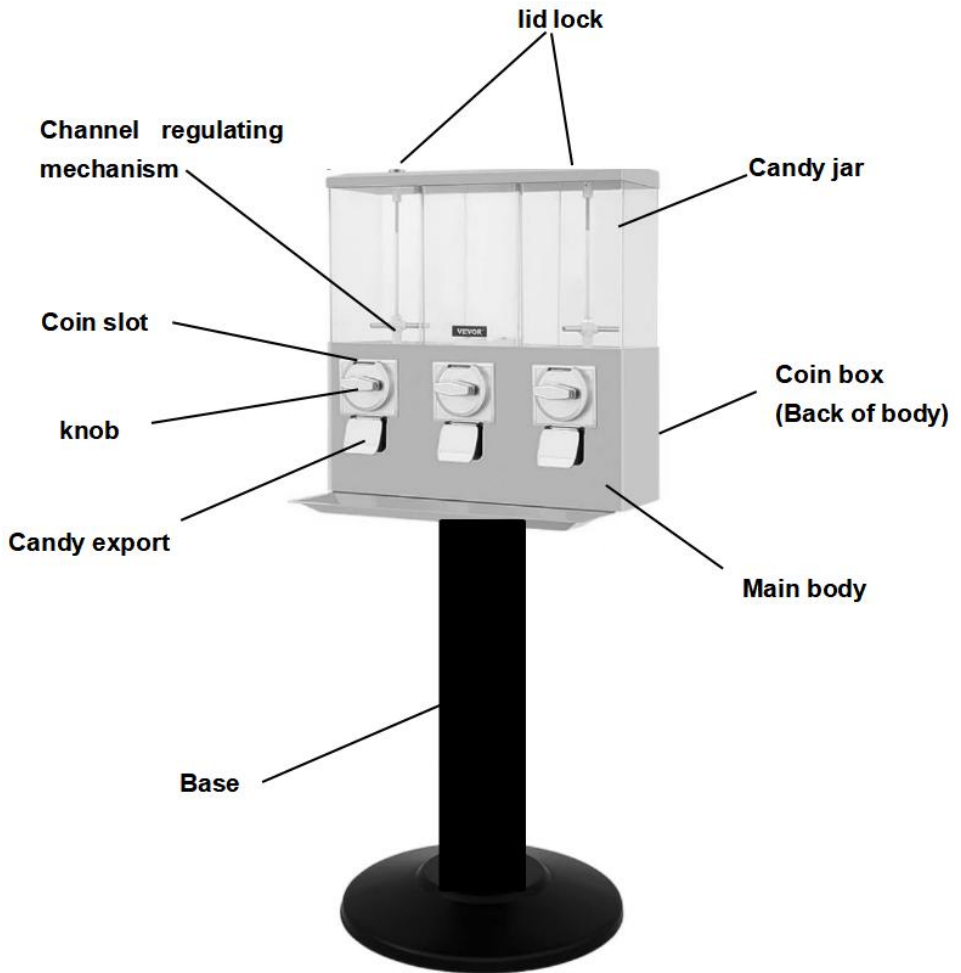

Model:AK29-11

User guide

1.Candy aisle setup

- A)** Unlock and open globe lid by unscrewing lock.
- B)** Remove two post screws holding globe to hopper.
- C)** Remove candy brush plate from the hopper
- D)** Lift up adjuster plate and move to the desired wheel setting

Cleaning

-Clean the candy jar regularly with a soft cloth and remove the coins inside the body

Manufacturer: Shanghaimuxinmuyeyouxiangongsi

Address: Baoshanqu Shuangchenglu 803long 11hao 1602A-1609shi
Shanghai

Imported to AUS:SIHAO PTY LTD.1 ROKEVA STREETEASTWOOD
NSW 2122 Australia

Imported to USA:Sanven Technology Ltd. Suite 250,9166 Anaheim
Place,Rancho Cucamonga,CA91730



Pooledas Group Ltd
Unit 5 Albert Edward House,
The Pavilions Preston, United Kingdom
pooledas123@gmail.com
01772418127

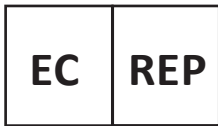

SHUNSHUN GmbH
Römeräcker 9 Z2021,76351
Linkenheim-Hochstetten, Germany
euvertreter@gmail.com
+49 1727041930

VEVOR[®]

TOUGH TOOLS, HALF PRICE

Support and E-Warranty Certificate

www.vevor.com/support

VEVOR[®]

TOUGH TOOLS, HALF PRICE

Technique Assistance et certificat de garantie électronique

www.vevor.com/support

Distributeur automatique de bonbons

We continue to be committed to provide you tools with competitive price.

"Save Half", "Half Price" or any other similar expressions used by us only represents an estimate of savings you might benefit from buying certain tools with us compared to the major top brands and does not necessarily mean to cover all categories of tools offered by us. You are kindly reminded to verify carefully when you are placing an order with us if you are actually saving half in comparison with the top major brands.

VEVOR®

TOUGH TOOLS, HALF PRICE

Candy Vending Machine

MODÈLE : AK19-08 MODÈLE : AK29-11

(ROUGE/JAUNE/NOIR) (BLEU)



NEED HELP? CONTACT US!

Have product questions? Need technical support? Please feel free to contact us:

Technical Support and E-Warranty Certificate
www.vevor.com/support

This is the original instruction, please read all manual instructions carefully before operating. VEVOR reserves a clear interpretation of our user manual. The appearance of the product shall be subject to the product you received. Please forgive us that we won't inform you again if there are any technology or software updates on our product.

PARAMÈTRES DU PRODUIT

Nom du produit : _	Distributeur automatique de bonbons	
Modèle:	Ak19-08	ak29-11
du produit :	210x200x430mm	215x200x410mm
Couleur du produit : _	Rouge / Jaune / Noir Trois types	Bleu
Boite de bonbons:	3 PIÈCES	4 PIÈCES
Capacité des bonbons :	Environ 8LBS / Boîte à bonbons	
Capacité de la boule de gomme :	Environ 320 boules de gomme de 1" / Boîte à bonbons	
Type de pièce :	Vingt-cinq cents	

PRÉCAUTIONS D'UTILISATION



AVERTISSEMENT:

1. Les distributeurs automatiques sont conçus pour fonctionner avec du bubble-gum de 0,9 à 1,3 pouces/un petit œuf torsadé/une boule à force unique. Les capsules ou billes de différentes tailles ne fonctionneront pas avec cette machine.
2. Veuillez utiliser un chiffon propre pour nettoyer le bac à sucre avant de verser les bonbons.
3. Ne tirez pas violemment lorsque vous l'utilisez.
4. Veuillez définir les bonbons selon les paramètres décrits dans les spécifications.

5. Veuillez ne pas placer le produit à l'extérieur pour éviter la pluie.

CONSERVEZ CES INSTRUCTIONS

Présentation du produit

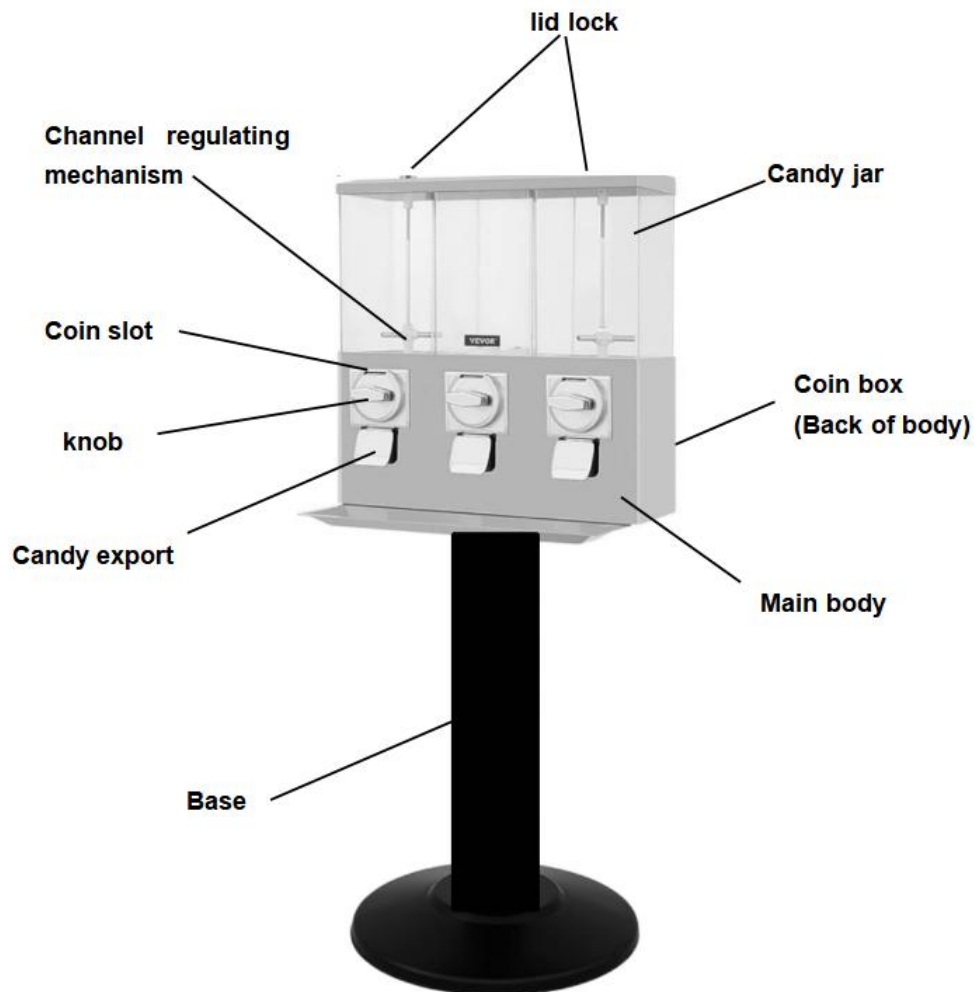

Modèle:AK19-08

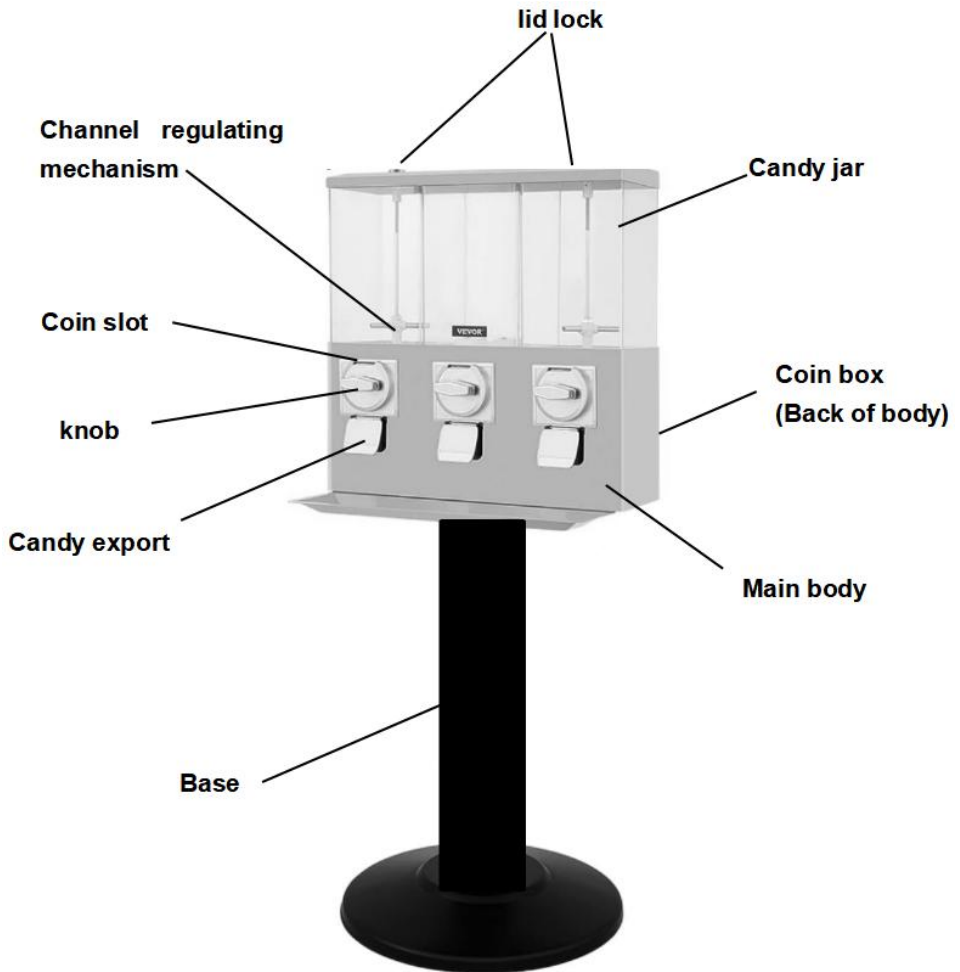

Modèle:AK29-11

Mode d'emploi

1. Configuration de l'allée des bonbons

- A) Déverrouillez et ouvrez le couvercle du globe en dévissant le verrou.
- B) Retirez les deux vis de poteau retenant le globe à la trémie.
- C) Retirez la plaque à pinceaux à bonbons de la trémie.
- D) Soulevez la plaque de réglage et déplacez-la jusqu'à l'encoche de

réglage de la roue souhaitée (fig.2). encoche n°1 (l'encoche au loin à gauche) est destiné aux plus petites ventes et l'encoche n°5 est destinée aux plus grandes ventes. Si vous le souhaitez, la plaque de réglage peut être entièrement retirée pour la vente de gros produits tels que les cacahuètes M&M.

E) Vous devez utiliser la roue à gommages de 1-3/8" et la plaque à brosse pour les boules de gomme ou les capsules. La roue à gommages est installée en installant d'abord la colonne montante (Fig.3). L'ouverture de la colonne montante doit faire face à l'avant du vendeur. Ensuite, installez une roue pour boules de gomme de sorte que l'un des trous de distribution soit positionné au-dessus de l'ouverture de la colonne montante. Installez la plaque de brosse pour boules de gomme. Desserrez la (1) vis de réglage sur le dessus de la roue pour boules de gomme située à côté de chaque cavité pour boules de gomme. Tournez la molette de réglage pour ajuster l'ouverture en fonction du produit ventilé. Les ressorts de la plaque brosse à boules de gomme doivent être vers le monnayeur ou vers l'avant du vendeur.

2.Pour récupérer des pièces :

Ouvrez la tirelire avec la clé et sortez les pièces

Remarque : ne dépassez pas serrez le verrou car seul un ajustement parfait est nécessaire.

Si vous avez des questions sur notre produit, veuillez contacter notre service client ; merci!

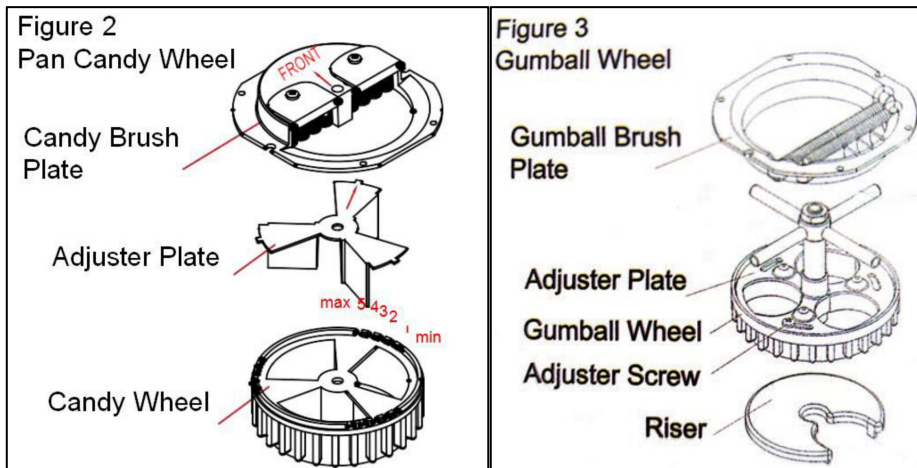

Nettoyage

-Nettoyez régulièrement le pot à bonbons avec un chiffon doux et retirez les pièces à l'intérieur du corps

Fabricant: Shanghaimuxinmuyeyouxiangongsi

Adresse: Baoshanqu Shuangchenglu 803long 11ha 1602A-1609shi
Shanghai

Importé à AUS : SIHAO PTY LTD.1 ROKEVA RUEESTBOIS
Nouvelle-Galles du Sud 2122 Australie

Importé à États-Unis : Sanven Technologie Ltd. Suite 250,9166 Anaheim
Lieu, Rancho Cucamonga,CA91730



Pooledas Group Ltd
Unit 5 Albert Edward House,
The Pavilions Preston, United Kingdom
pooledas123@gmail.com
01772418127



SHUNSHUN GmbH
Römeräcker 9 Z2021,76351
Linkenheim-Hochstetten, Germany
euvertreter@gmail.com
+49 1727041930

VEVOR[®]

TOUGH TOOLS, HALF PRICE

Assistance et certificat de garantie électronique

www.vevor.com/support

VEVOR[®]

TOUGH TOOLS, HALF PRICE

Technisch Support- und E-Garantie-Zertifikat www.vevor.com/support

Süßigkeitenautomat _

We continue to be committed to provide you tools with competitive price.

"Save Half", "Half Price" or any other similar expressions used by us only represents an estimate of savings you might benefit from buying certain tools with us compared to the major top brands and does not necessarily mean to cover all categories of tools offered by us. You are kindly reminded to verify carefully when you are placing an order with us if you are actually saving half in comparison with the top major brands.

VEVOR®

TOUGH TOOLS, HALF PRICE

Candy Vending Machine

MODELL: AK19-08. MODELL: AK29-11
(ROT / GELB / SCHWARZ) (BLAU)



NEED HELP? CONTACT US!

Have product questions? Need technical support? Please feel free to contact us:

Technical Support and E-Warranty Certificate
www.vevor.com/support

This is the original instruction, please read all manual instructions carefully before operating. VEVOR reserves a clear interpretation of our user manual. The appearance of the product shall be subject to the product you received. Please forgive us that we won't inform you again if there are any technology or software updates on our product.

PRODUKTPARAMETER

Produktname : _ _ _	Süßigkeitenautomat	
Modell:	Ak19-08	ak29-11
Produktgröße : _	210x200x430 mm	215x200x410mm
Produktfarbe : _ _ _	Rot / Gelb / Schwarz Drei Typen	Blau
Süßigkeiten Box:	3 Stück	4 STÜCK
Süßigkeitenkapa zität:	Ca. 8 Pfund / Bonbonschachtel	
Kaugummikapaz ität:	Ca. 320 2,5 cm große Kaugummikugeln/Süßigkeitenschachtel	
Münztyp:	Fünfundzwanzig Cent	

VORSICHTSMASSNAHMEN VERWENDEN



WARNUNG:

1. Verkaufsautomaten sind für die Verwendung von 0,9 – 1,3 Zoll großen Kaugummis/kleinen gedrehten Eiern/Kugeln mit einfacher Kraft ausgelegt. Kapseln oder Kugeln unterschiedlicher Größe funktionieren mit dieser Maschine nicht.
2. Bitte reinigen Sie den Zuckerbehälter mit einem sauberen Tuch, bevor Sie die Süßigkeiten einschenken.
3. Ziehen Sie bei der Verwendung nicht gewaltsam daran.
4. Bitte stellen Sie die Bonbons innerhalb der in der Spezifikation beschriebenen Parameter ein.
5. Bitte stellen Sie das Produkt nicht im Freien auf, um Regen zu

vermeiden.

ANLEITUNG AUFBEWAHREN

Produkteinführung

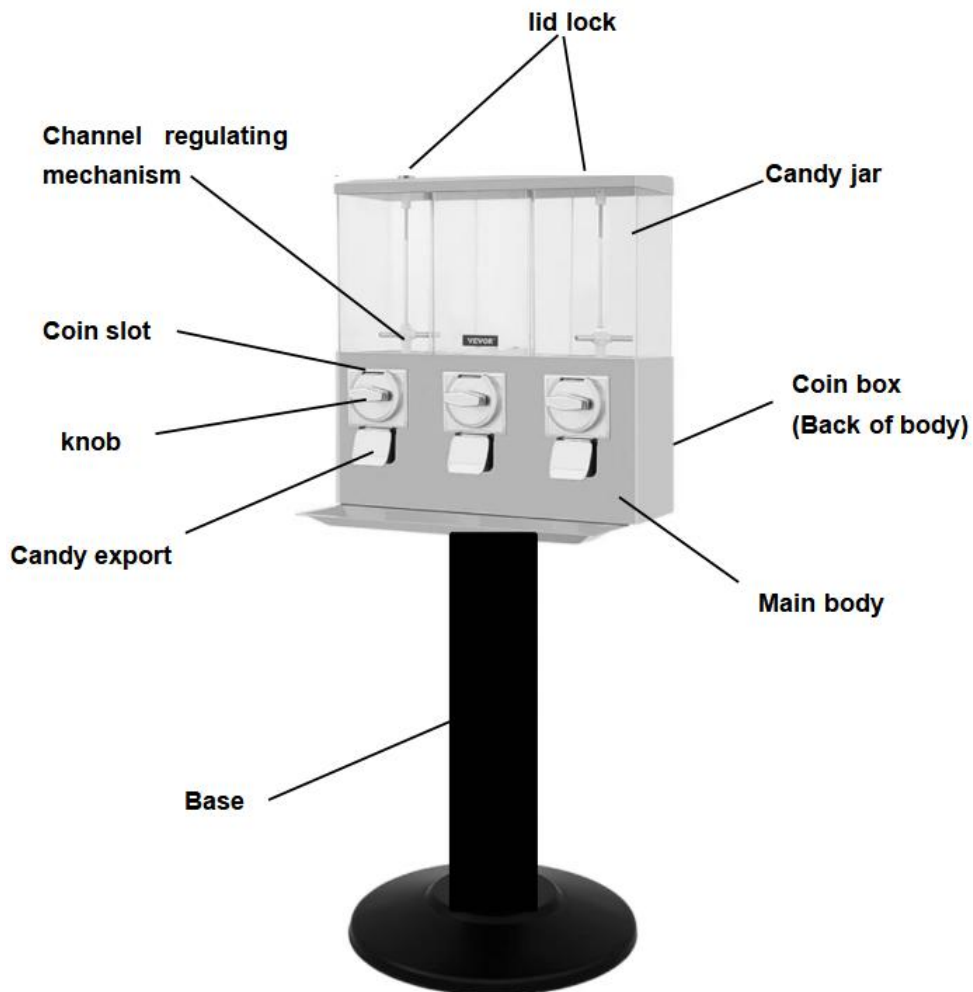

Modell: AK19-08

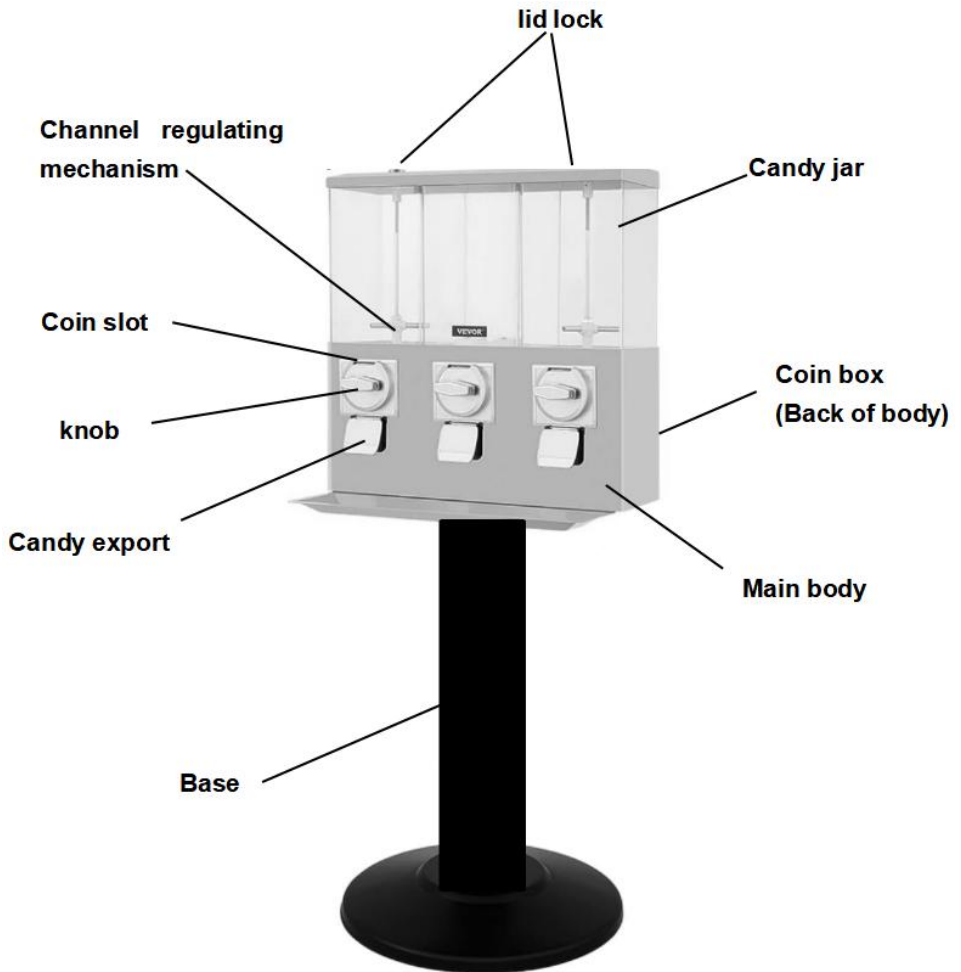

Modell: AK29-11

Benutzerhandbuch

1. Einrichtung des Süßigkeitengangs

A) Entriegeln und öffnen Sie den Globusdeckel, indem Sie das Schloss abschrauben.

B) Entfernen Sie die beiden Pfostenschrauben, mit denen die Kugel am Trichter befestigt ist.

C) Entfernen Sie die Candy-Bürstenplatte vom Trichter

D) Heben Sie die Einstellplatte an und stellen Sie sie auf die gewünschte Radeinstellkerbe ein (Abb. 2). Kerbe Nr. 1 (die Kerbe weiter entfernt, links) ist für die kleinsten Verkäufe und Kerbe Nr. 5 ist für die größten Verkäufe. Auf Wunsch kann die Einstellplatte vollständig entfernt werden, um große Produkte wie Erdnuss-M&M zu verkaufen.

E) Sie müssen das 1-3/8-Zoll-Gumball-Rad und die Bürstenplatte für Gumballs oder Kapseln verwenden. Das Gumball-Rad wird installiert, indem zuerst das Steigrohr installiert wird (Abb. 3). Die Öffnung des Steigrohrs muss zur Vorderseite des Verkäufers zeigen. Als nächstes installieren Sie ein Gumball-Rad, sodass eines der Verkaufslöcher über der Öffnung im Steigrohr positioniert ist. Installieren Sie die Gumball-Bürstenplatte. Lösen Sie die eine (1) Einstellschraube oben am Gumball-Rad, die sich neben jedem Gumball-Hohlraum befindet. Drehen Sie Verwenden Sie das Einstellrad, um die Öffnung entsprechend dem belüfteten Produkt anzupassen. Die Federn an der Gumball-Bürstenplatte müssen zum Münzmechanismus oder zur Vorderseite des Automaten zeigen.

2.Um Münzen abzurufen:

Öffnen Sie das Münzfach mit dem Schlüssel und entnehmen Sie die Münzen

Hinweis: Nicht übertreiben Ziehen Sie die Verriegelung fest, da nur ein fester Sitz erforderlich ist.

Wenn Sie Fragen zu unserem Produkt haben, wenden Sie sich bitte an unseren Kundenservice; Danke!

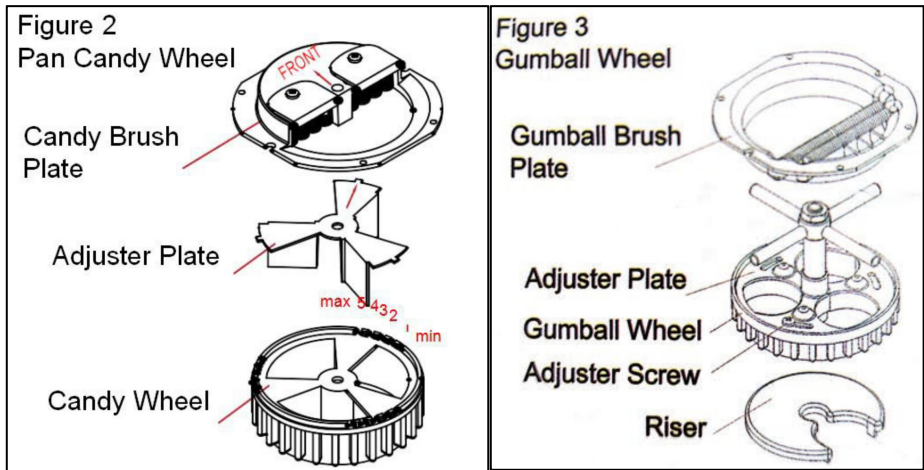

Reinigung

-Reinigen Sie das Bonbonglas regelmäßig mit einem weichen Tuch und entfernen Sie die Münzen im Gehäuse

Hersteller: Shanghaimuxinmuyeyouxiangongsi

Adresse: Baoshanqu Shuangchenglu 803lang 11hao 1602A-1609shi
Shanghai

Importiert Zu AUS: SIHAO PTY LTD.1 ROKEVA STREETEASTWOOD
NSW 2122 Australien

Importiert Zu USA: Sanven Technologie GmbH. Suite 250.9166 Anaheim
Ort, Rancho Cucamonga, CA91730



Pooledas Group Ltd
Unit 5 Albert Edward House,
The Pavilions Preston, United Kingdom
pooledas123@gmail.com
01772418127



SHUNSHUN GmbH
Römeräcker 9 Z2021,76351
Linkenheim-Hochstetten, Germany
euvertreter@gmail.com
+49 1727041930

VEVOR[®]

TOUGH TOOLS, HALF PRICE

Support- und E-Garantiezertifikat

www.vevor.com/support

VEVOR[®]

TOUGH TOOLS, HALF PRICE

Tecnico Supporto e certificato di garanzia elettronica www.vevor.com/support

Distributore automatico di caramelle

We continue to be committed to provide you tools with competitive price.

"Save Half", "Half Price" or any other similar expressions used by us only represents an estimate of savings you might benefit from buying certain tools with us compared to the major top brands and does not necessarily mean to cover all categories of tools offered by us. You are kindly reminded to verify carefully when you are placing an order with us if you are actually saving half in comparison with the top major brands.

VEVOR®

TOUGH TOOLS, HALF PRICE

Candy Vending Machine

MODELLO: AK19-08 MODELLO: AK29-11

(ROSSO/GIALLO/NERO) (BLU)



NEED HELP? CONTACT US!

Have product questions? Need technical support? Please feel free to contact us:

Technical Support and E-Warranty Certificate
www.vevor.com/support

This is the original instruction, please read all manual instructions carefully before operating. VEVOR reserves a clear interpretation of our user manual. The appearance of the product shall be subject to the product you received. Please forgive us that we won't inform you again if there are any technology or software updates on our product.

PARAMETRI DEL PRODOTTO

Nome del prodotto : _	Distributore automatico di caramelle	
Modello:	Ak19-08	ak29-11
del prodotto :	210x200x430 mm	215x200x410 mm
Colore del prodotto : _	Rosso/Giallo/Nero Tre tipi	Blu
Scatola di caramelle:	3 pezzi	4 pezzi
Capacità caramelle:	Circa 8 libbre/scatola di caramelle	
Capacità della gomma da masticare:	Circa 320 caramelle gommosse da 1 pollice/scatola di caramelle	
Tipo di moneta:	Venticinque centesimi	

USARE LE PRECAUZIONI



AVVERTIMENTO:

1. I distributori automatici sono progettati per funzionare con gomme da masticare da 0,9-1,3 pollici/uovo ritorto/sfera a forza singola. Capsule o palline di dimensioni diverse non funzionano con questa macchina.
2. Utilizzare un panno pulito per pulire il contenitore dello zucchero prima di versare le caramelle;
3. Non tirare violentemente durante l'utilizzo.
4. Impostare le caramelle entro i parametri descritti nelle specifiche.
5. Si prega di non posizionare il prodotto all'aperto per evitare la pioggia.

CONSERVA QUESTE ISTRUZIONI

Introduzione al prodotto

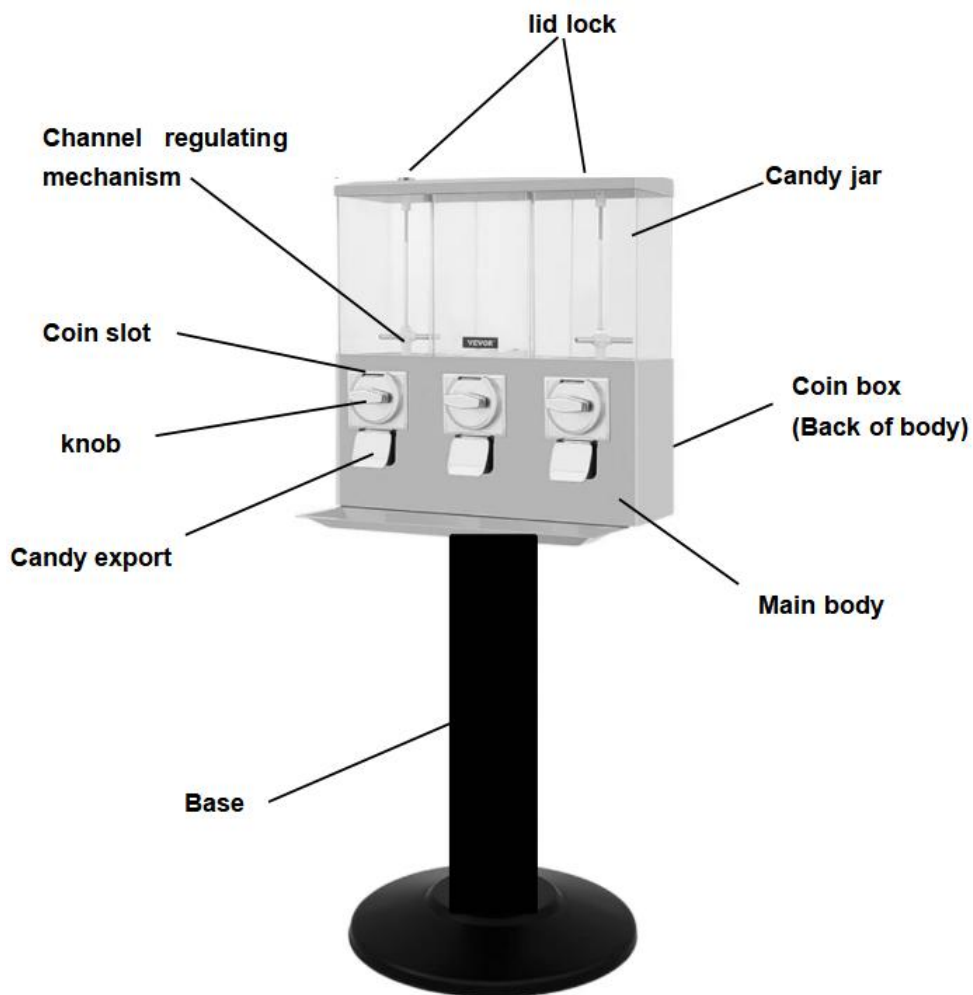

Modello: AK19-08

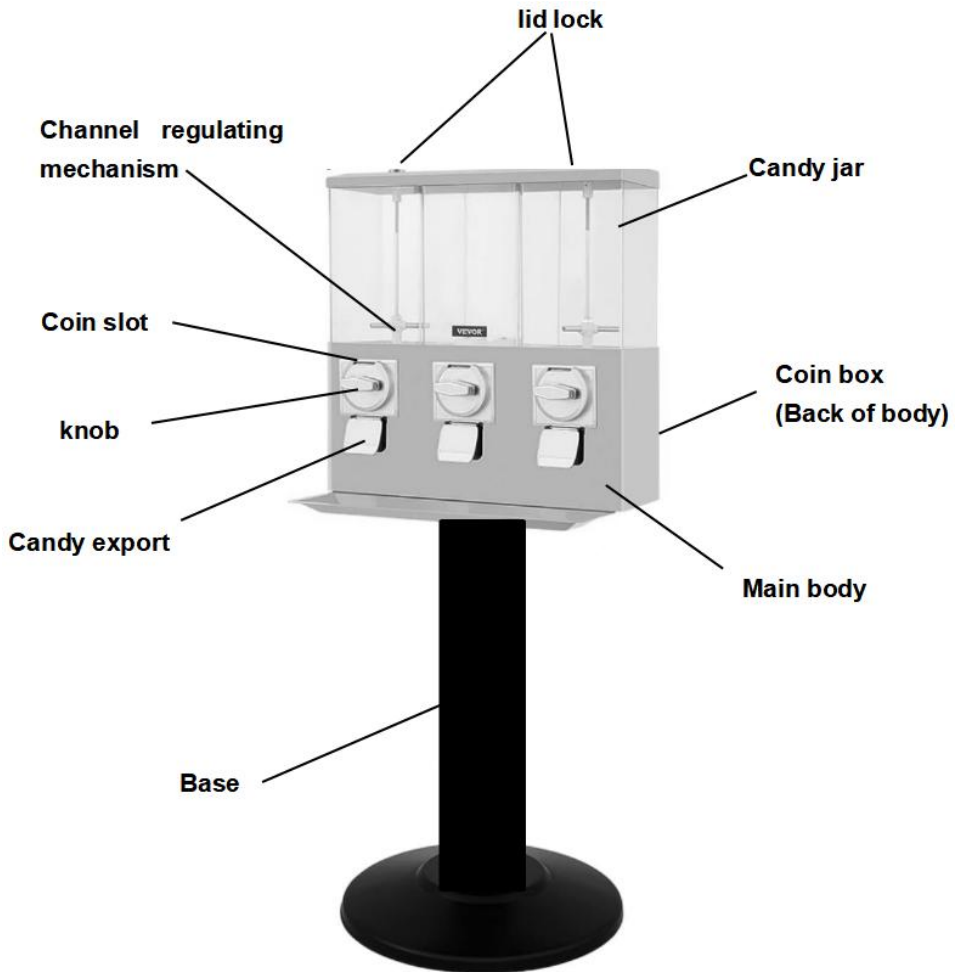

Modello: AK29-11

Guida utente

1. Configurazione del corridoio Candy

- A)** Sbloccare e aprire il coperchio del globo svitando la serratura.
- B)** Rimuovere le due viti del montante che fissano il globo alla tramoggia.
- C)** Rimuovere la piastra della spazzola per caramelle dalla tramoggia
- D)** Sollevare la piastra di regolazione e spostarsi sulla tacca di

regolazione della ruota desiderata (fig.2). tacca n. 1 (la tacca più lontana a sinistra) è per le vendite più piccole e la tacca n. 5 è per le vendite più grandi. Se lo si desidera, la piastra di regolazione può essere rimossa completamente per la vendita di prodotti di grandi dimensioni come M&M alle arachidi.

E) È necessario utilizzare la ruota per gumball da 1-3/8" e la piastra della spazzola per gomme da masticare o capsule. La ruota per gumball viene installata installando prima il montante (Fig.3). L'apertura del montante deve essere rivolta verso la parte anteriore del venditore.

Successivamente, installare una ruota del gumball in modo che uno dei fori di distribuzione sia posizionato sopra l'apertura nel montante.

Installare la piastra della spazzola del gumball. Allentare una (1) vite di regolazione sulla parte superiore della ruota del gumball situata accanto a ciascuna cavità del gumball. Girare la rotella di regolazione per regolare l'apertura in base al prodotto scaricato Le molle del piatto spazzola del gumball devono essere rivolte verso la gettoniera o verso la parte anteriore del distributore.

2.Per recuperare le monete:

Apri la gettoniera con la chiave ed estrai le monete

Nota: non superare stringere il fermo poiché è necessaria solo una perfetta aderenza.

Se hai domande sul nostro prodotto, contatta il nostro servizio clienti;

Grazie!

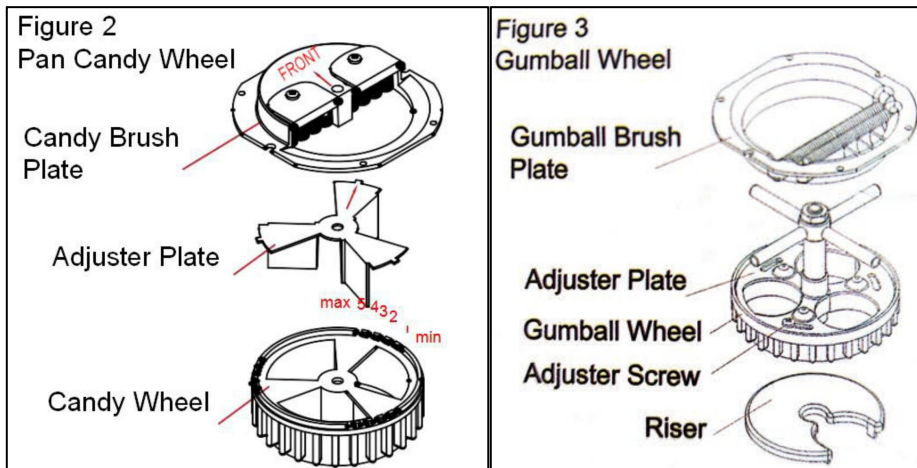

Pulizia

-Pulire regolarmente il barattolo delle caramelle con un panno morbido e rimuovere le monete all'interno del corpo

Produttore: Shanghaimuxinmuyeyouxiangongsi

Indirizzo: Baoshanqu Shuangchenglu 803 lungo 11hao 1602A-1609shi
Shangai

Importato A Australia: SIHAO PTY LTD.1 ROKEVA
STREETEASTWOOD

Nuovo Galles del Sud 2122 Australia

Importato A Stati Uniti: Sanven Tecnologia Ltd. Suite 250,9166 Anaheim
Posto, Rancho Cucamonga,CA91730



Pooledas Group Ltd
Unit 5 Albert Edward House,
The Pavilions Preston, United Kingdom
pooledas123@gmail.com
01772418127

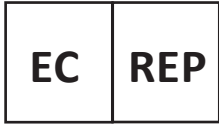

SHUNSHUN GmbH
Römeräcker 9 Z2021,76351
Linkenheim-Hochstetten, Germany
euvertreter@gmail.com
+49 1727041930

VEVOR[®]

TOUGH TOOLS, HALF PRICE

Supporto e certificato di garanzia elettronica

www.vevor.com/support

VEVOR[®]

TOUGH TOOLS, HALF PRICE

Técnico Soporte y certificado de garantía electrónica www.vevor.com/support

Máquina expendedora de dulces

We continue to be committed to provide you tools with competitive price.

"Save Half", "Half Price" or any other similar expressions used by us only represents an estimate of savings you might benefit from buying certain tools with us compared to the major top brands and does not necessarily mean to cover all categories of tools offered by us. You are kindly reminded to verify carefully when you are placing an order with us if you are actually saving half in comparison with the top major brands.

VEVOR®

TOUGH TOOLS, HALF PRICE

Candy Vending Machine

MODELO: AK19-08 MODELO: AK29-11
(ROJO / AMARILLO / NEGRO) (AZUL)



NEED HELP? CONTACT US!

Have product questions? Need technical support? Please feel free to contact us:

Technical Support and E-Warranty Certificate
www.vevor.com/support

This is the original instruction, please read all manual instructions carefully before operating. VEVOR reserves a clear interpretation of our user manual. The appearance of the product shall be subject to the product you received. Please forgive us that we won't inform you again if there are any technology or software updates on our product.

PARAMETROS DEL PRODUCTO

Nombre del producto : _	Máquina expendedora de dulces	
Modelo:	Ak19-08	ak29-11
del producto :	210x200x430mm	215x200x410mm
Color del producto : _	Rojo / Amarillo / Negro Tres tipos	Azul
Caja de dulces:	3 PIEZAS	4 PIEZAS
Capacidad de caramelos:	Aproximadamente 8 libras/caja de dulces.	
Capacidad de chicles:	Aproximadamente 320 chicles de 1"/caja de dulces	
Tipo de moneda:	Veinticinco centavos	

PRECAUCIONES DE USO



ADVERTENCIA:

1. Las máquinas expendedoras están diseñadas para funcionar con chicle de 0,9 a 1,3 pulgadas/huevo pequeño retorcido/bola de fuerza única. Las cápsulas o bolas de diferentes tamaños no funcionarán con esta máquina.
2. Utilice un paño limpio para limpiar el depósito de azúcar antes de verter el caramelo;
3. No tire violentamente cuando lo utilice.
4. Configure los dulces dentro de los parámetros descritos en las especificaciones.
5. No coloque el producto al aire libre para evitar la lluvia.

GUARDA ESTAS INSTRUCCIONES

Introducción del producto

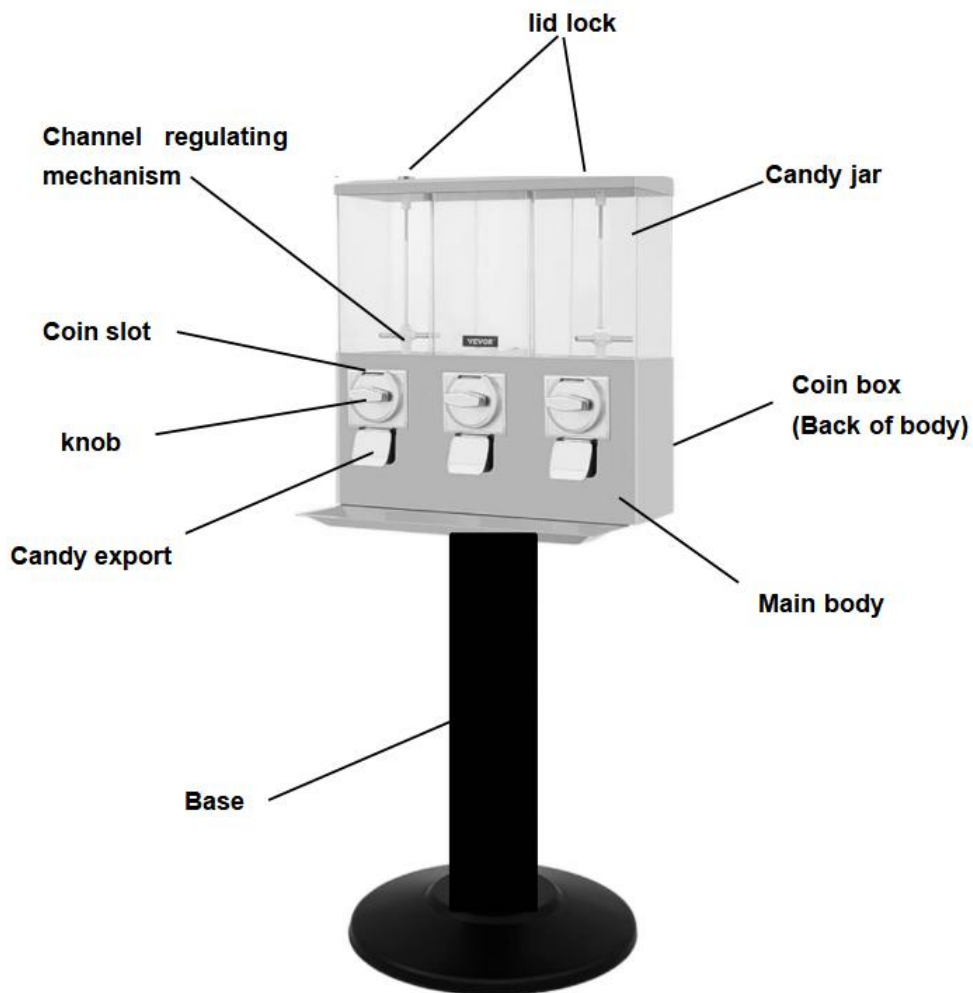

Modelo:AK19-08

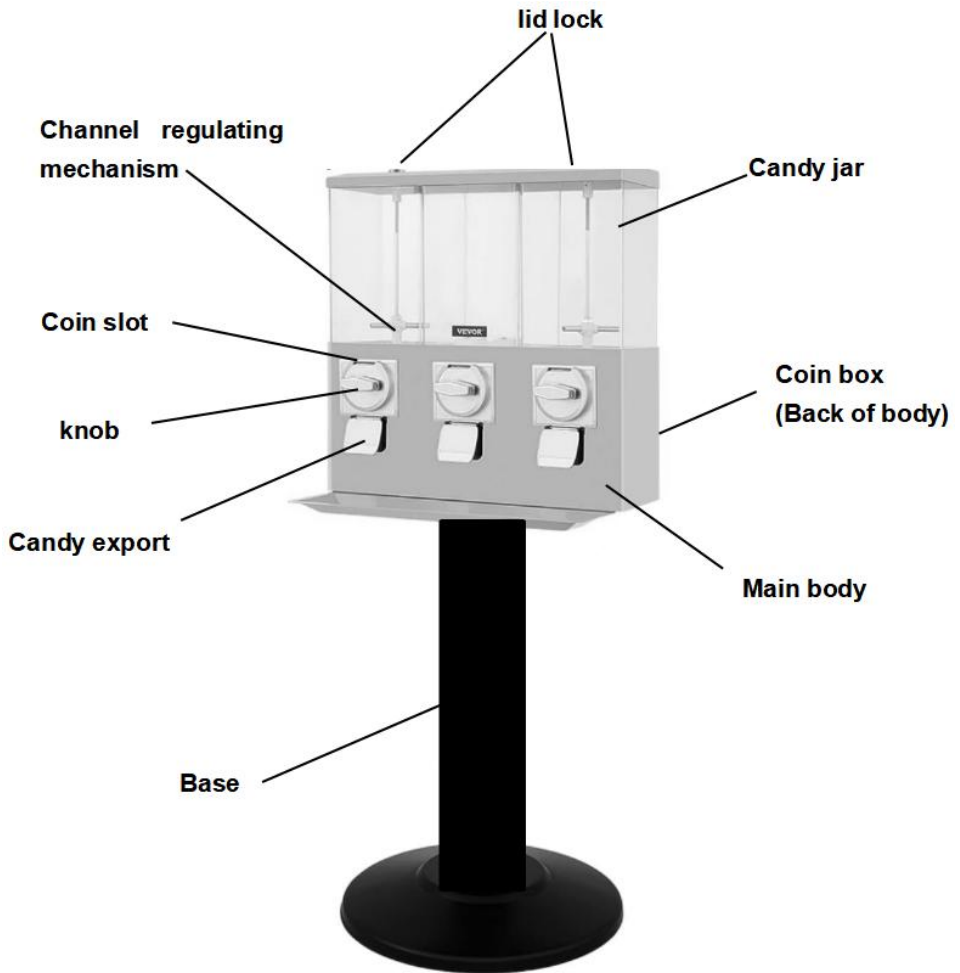

Modelo:AK29-11

Guía del usuario

1.Configuración del pasillo de dulces

- A)** Desbloquee y abra la tapa del globo desenroscando el seguro.
- B)** Retire los dos tornillos del poste que sujetan el globo a la tolva.
- C)** Retire la placa del cepillo para dulces de la tolva.
- D)** Levante la placa de ajuste y muévela a la muesca de ajuste de rueda

deseada (fig.2). muesca #1 (la muesca más alejada izquierda) es para las ventas más pequeñas y la muesca #5 es para las ventas más grandes. Si lo desea, la placa de ajuste se puede quitar por completo para vender productos grandes como M&M de maní.

E) Debe usar la rueda de chicles de 1-3/8" y la placa de cepillo para chicles o cápsulas. La rueda de chicles se instala instalando primero el elevador (Fig.3). La abertura del elevador debe mirar hacia el frente del vendedor. Luego, instale una rueda de chicle de modo que uno de los orificios de venta quede colocado sobre la abertura en el elevador. Instale la placa del cepillo de chicle. Afloje el (1) tornillo de ajuste en la parte superior de la rueda de chicle ubicada al lado de cada cavidad de chicle. Gire la rueda de ajuste para ajustar la apertura según el producto ventilado. Los resortes en la placa del cepillo de chicles deben estar hacia el monedero o el frente del expendedor.

2. Para recuperar monedas:

Abre la caja de monedas con la llave y saca las monedas.

Nota: no te excedas apriete la cerradura ya que sólo es necesario un ajuste perfecto.

Si tiene alguna pregunta sobre nuestro producto, póngase en contacto con nuestro servicio de atención al cliente; ¡gracias!

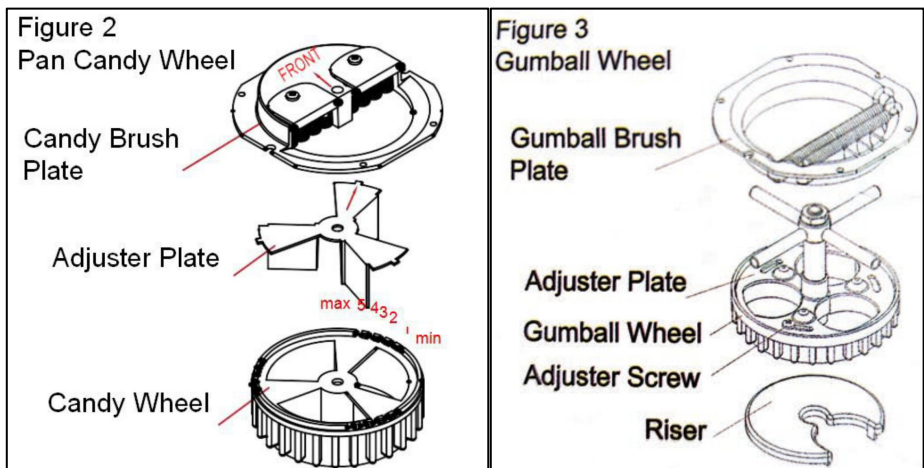

Limpieza

-Limpia el tarro de caramelos periódicamente con un paño suave y retira las monedas del interior del cuerpo.

Fabricante: Shanghaimuxinmuyeyouxiangongsi

DIRECCIÓN: Baoshanqu Shuangchenglu 803largo 11hao 1602A-1609shi
Llevar a la fuerza

Importado a AUS: SIHAO PTY LTD.1 ROKEVA CALLE ASTWOOD
Nueva Gales del Sur 2122 Australia

Importado a Estados Unidos: Sanven Tecnología Limitado. Suite
250,9166 anaheim
Lugar, Rancho Cucamonga,CA91730



Pooledas Group Ltd
Unit 5 Albert Edward House,
The Pavilions Preston, United Kingdom
pooledas123@gmail.com
01772418127



SHUNSHUN GmbH
Römeräcker 9 Z2021,76351
Linkenheim-Hochstetten, Germany
euvertreter@gmail.com
+49 1727041930

VEVOR[®]

TOUGH TOOLS, HALF PRICE

Certificado de soporte y garantía electrónica

www.vevor.com/support

VEVOR[®]

TOUGH TOOLS, HALF PRICE

Techniczny Certyfikat wsparcia i e-gwarancji www.vevor.com/support

Automat ze słodyczami

We continue to be committed to provide you tools with competitive price.

"Save Half", "Half Price" or any other similar expressions used by us only represents an estimate of savings you might benefit from buying certain tools with us compared to the major top brands and does not necessarily mean to cover all categories of tools offered by us. You are kindly reminded to verify carefully when you are placing an order with us if you are actually saving half in comparison with the top major brands.

VEVOR®

TOUGH TOOLS, HALF PRICE

Candy Vending Machine

MODEL: AK19-08 MODEL: AK29-11

(CZERWONY / ŻÓŁTY / CZARNY) (NIEBIESKI)



NEED HELP? CONTACT US!

Have product questions? Need technical support? Please feel free to contact us:

Technical Support and E-Warranty Certificate
www.vevor.com/support

This is the original instruction, please read all manual instructions carefully before operating. VEVOR reserves a clear interpretation of our user manual. The appearance of the product shall be subject to the product you received. Please forgive us that we won't inform you again if there are any technology or software updates on our product.

PARAMETRY PRODUKTU

Nazwa produktu : _ _	Automat ze słodyczami	
Model:	Ak19-08	ak29-11
Rozmiar produktu :	210 x 200 x 430 mm	215x200x410mm
Kolor produktu : --	Czerwony / żółty / czarny Trzy typy	Niebieski
Pudełko słodyczy:	3 SZT	4szt
Pojemność cukierków:	Okolo 8 funtów / pudełko cukierków	
Pojemność Gumballa:	Okolo 320 1-calowych gumek do żucia / pudełka cukierków	
Rodzaj monety:	Dwadzieścia pięć centów	

STOSOWAĆ ŚRODKI OSTROŻNOŚCI



OSTRZEŻENIE:

1. Automaty sprzedające są przeznaczone do pracy z gumą balonową o średnicy 0,9 - 1,3 cala/małym skręconym jajkiem/kulką o pojedynczej sile. Kapsułki lub kulki o różnych rozmiarach nie będą działać w tym urządzeniu.
2. Przed wsypaniem cukierków wyczyść pojemnik na cukier czystą szmatką;
3. Nie ciągnij gwałtownie podczas używania.
4. Prosimy o ustawienie cukierków w zakresie parametrów opisanych w specyfikacji.

5. Proszę nie ustawiać produktu na zewnątrz, aby uniknąć deszczu.

ZACHOWAJ TE INSTRUKCJE

Wprowadzenie produktów

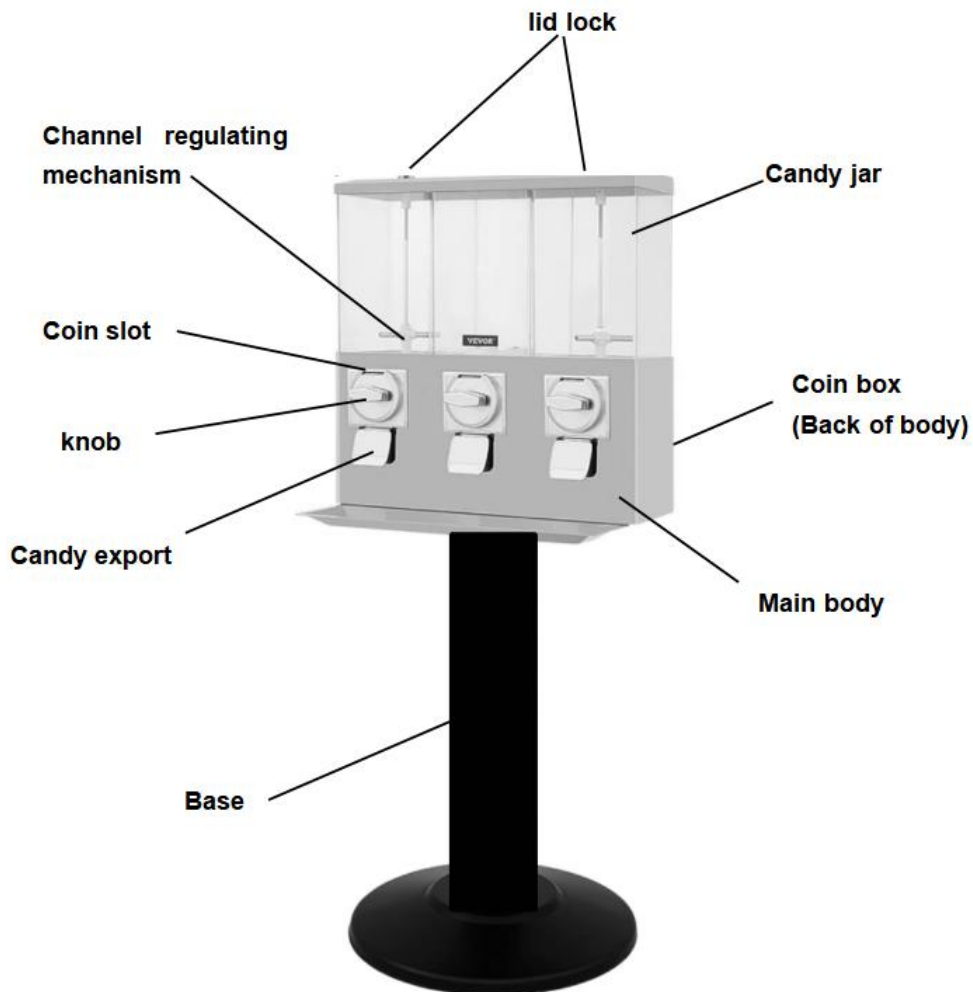

Model:AK19-08

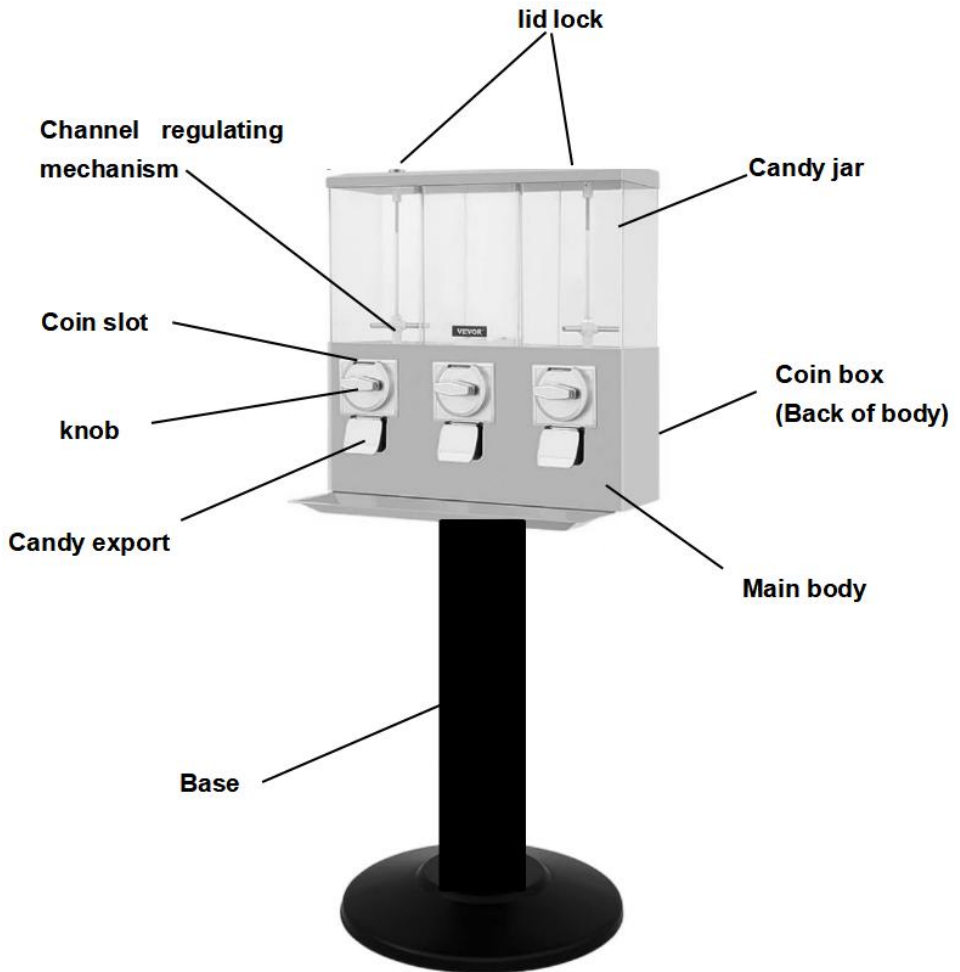

Model:AK29-11

Podręcznik użytkownika

1. Konfiguracja przejścia ze słodyczami

- Odblokuj i otwórz pokrywę kuli poprzez odkręcenie zamka.
- Wykręć dwie śruby słupkowe mocujące kulę do leja.
- Wyjmij płytkę pędzla do cukierków z leja zasypowego
- Podnieś płytkę regulacyjną i przesunij dożądanego wycięcia

ustawienia koła (rys.2). wycięcie nr 1 (wycięcie daleko po lewej) jest przeznaczony dla najmniejszych sklepów, a wycięcie nr 5 dla największych. W razie potrzeby płytkę regulacyjną można całkowicie zdjąć w celu sprzedaży dużych produktów, takich jak M&M z orzeszkami ziemnymi.

E) Do gumballi lub kapsulek należy użyć kółka i szczoteczki 1-3/8" oraz płytki szczotkowej. Kółko do gumy instaluje się, instalując najpierw podstawkę (rys. 3). Otwór podkładki musi być skierowany w stronę przodu sprzedawcy. Następnie zamontuj kółko do gumek Tak, aby jeden z otworów do sprzedaży znajdował się nad otworem w podstawie. Zamontuj płytkę szczoteczki do gumek. Poluzuj jedną (1) śrubę regulacyjną na górze kółka do gumek, znajdującą się obok każdego wgłębienia na gumki. Obróć pokrętko regulacyjne, aby wyregulować otwór w zależności od wentylowanego produktu. Sprężyny na płycie szczoteczki do gumy muszą być skierowane w stronę mechanizmu monetowego lub przodu sprzedawcy.

2. Aby odzyskać monety:

Otwórz skrzynkę na monety kluczem i wyjmij monety

Uwaga: nie przekraczaj dokręć blokadę, ponieważ konieczne jest jedynie dokładne dopasowanie.

Jeśli masz jakiegokolwiek pytania dotyczące naszego produktu, skontaktuj się z naszym działem obsługi klienta; Dziękuję!

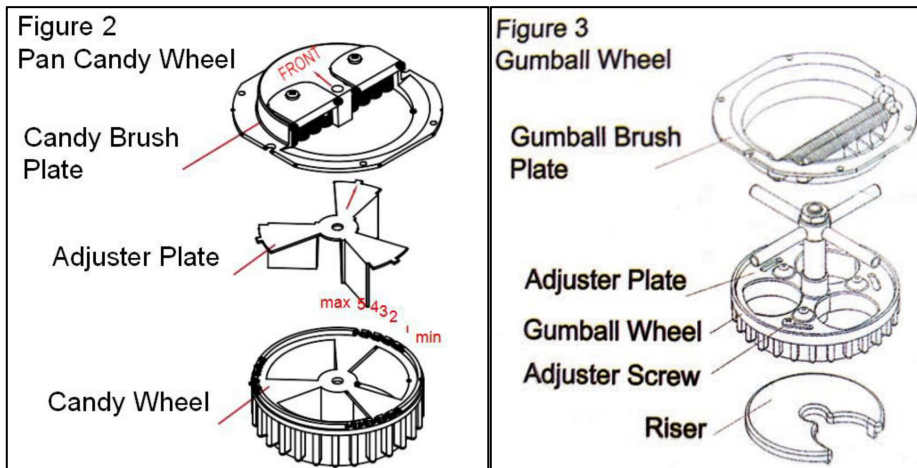

Czyszczenie

- Regularnie czyść słoik po cukierkach miękką szmatką i usuwaj monety znajdujące się w korpusie

Producent: Shanghaimuxinmuyeyouxiangongsi

Adres: Baoshanqu Shuangchenglu 803długa 11hao 1602A-1609shi
Szanghaj

Importowany Do AUS: SIHAO PTY LTD.1 ROKEVA
STREETEASTWOOD

Nowa Południowa Walia 2122 Australia

Importowany Do USA: Sanven Technologia Sp. z o.o. Zestaw 250,9166
Anaheim

Miejsce, Rancho Cucamonga, CA91730



Pooledas Group Ltd
Unit 5 Albert Edward House,
The Pavilions Preston, United Kingdom
pooledas123@gmail.com
01772418127



SHUNSHUN GmbH
Römeräcker 9 Z2021,76351
Linkenheim-Hochstetten, Germany
euvertreter@gmail.com
+49 1727041930

VEVOR[®]

TOUGH TOOLS, HALF PRICE

Certyfikat wsparcia i e-gwarancji

www.vevor.com/support

VEVOR[®]

TOUGH TOOLS, HALF PRICE

Technisch Ondersteuning en e-garantiecertificaat www.vevor.com/support

Snoepautomaat _

We continue to be committed to provide you tools with competitive price.

"Save Half", "Half Price" or any other similar expressions used by us only represents an estimate of savings you might benefit from buying certain tools with us compared to the major top brands and does not necessarily mean to cover all categories of tools offered by us. You are kindly reminded to verify carefully when you are placing an order with us if you are actually saving half in comparison with the top major brands.

VEVOR®

TOUGH TOOLS, HALF PRICE

Candy Vending Machine

MODEL: AK19-08 MODEL: AK29-11

(ROOD / GEEL / ZWART) (BLAUW)



NEED HELP? CONTACT US!

Have product questions? Need technical support? Please feel free to contact us:

Technical Support and E-Warranty Certificate
www.vevor.com/support

This is the original instruction, please read all manual instructions carefully before operating. VEVOR reserves a clear interpretation of our user manual. The appearance of the product shall be subject to the product you received. Please forgive us that we won't inform you again if there are any technology or software updates on our product.

PRODUCTPARAMETERS

Productnaam : _ _ _	Snoepautomaat	
Model:	Ak19-08	ak29-11
Product grootte :	210x200x430 mm	215x200x410mm
P roductkleur : _ _	Rood / Geel / Zwart Drie soorten	Blauw
Snoepdoos:	3 STUKS	4 STUKS
Snoepcapaciteit :	Ongeveer 8 pond / snoepdoos	
Kauwgomballen capaciteit:	Ongeveer 320 kauwgomballen / snoepdoos van 1 inch	
Muntsoort:	Vijfentwintig cent	

GEBRUIK VOORZORGSMAATREGELEN



WAARSCHUWING:

1. Verkoopautomaten zijn ontworpen om te werken met kauwgom van 0,9 - 1,3 inch / klein gedraaid ei / bal met enkele kracht. Capsules of balletjes van verschillende groottes werken niet met deze machine.
2. Gebruik een schone doek om het suikerbakje schoon te maken voordat je het snoepje giet;
3. Trek niet gewelddadig tijdens het gebruik.
4. Stel de snoepjes in binnen de parameters die in de specificatie worden beschreven.
5. Zet het product niet buiten om regen te voorkomen.

BEWAAR DEZE INSTRUCTIES

Product Introductie

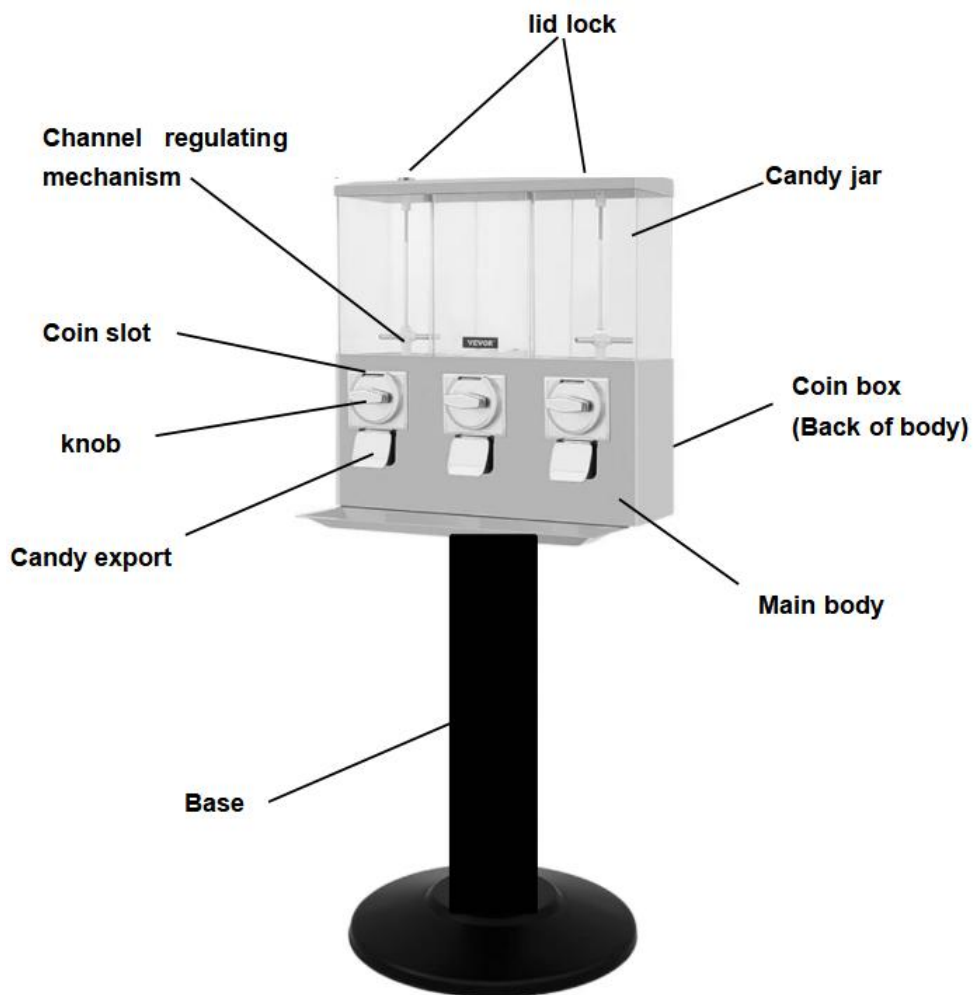

Model:AK19-08

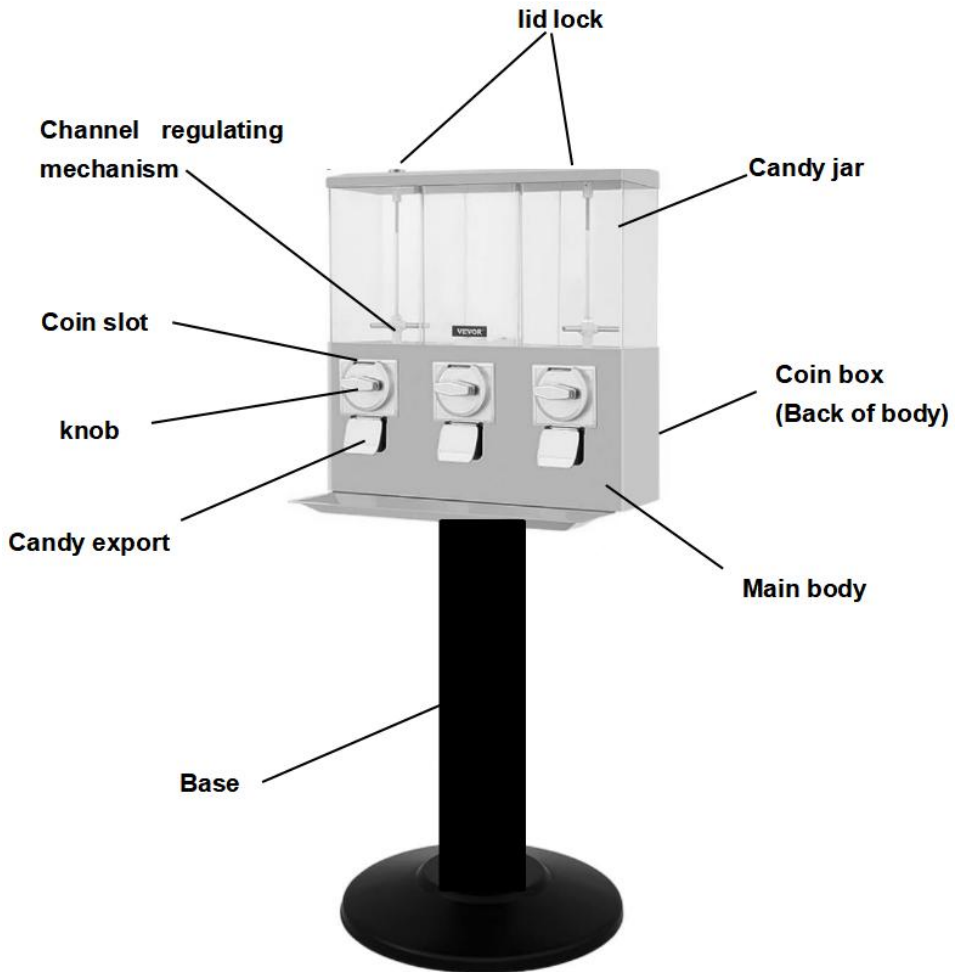

Model:AK29-11

Gebruikershandleiding

1. Snoepgangpadopstelling

- A) Ontgrendel en open het wereldboldeksel door het slot los te draaien.
- B) Verwijder de twee postschroeven waarmee de bol aan de trechter is bevestigd.
- C) Verwijder de snoepborstelplaat uit de trechter

D) Til de afstelplaat op en verplaats deze naar de gewenste inkeping voor de wielinstelling (fig.2). inkeping #1 (de inkeping tot het uiterste links) is voor de kleinste verkopen en inkeping#5 is voor de grootste verkopen. Indien gewenst kan de stelplaat geheel worden verwijderd voor het verkopen van grote producten zoals pinda-M&M.

E) U moet het 1-3/8" kauwgomballenwiel en de borstelplaat gebruiken voor kauwgomballen of capsules. Het kauwgomballenwiel wordt geïnstalleerd door eerst de stijgbuis te installeren (Fig.3). De opening van de stijgbuis moet naar de voorkant van de verkoper gericht zijn. Installeer vervolgens een kauwgomballenwiel, zodat een van de verkoopgaten zich boven de opening in de stijgbuis bevindt. Installeer de kauwgomballenborstelplaat. Draai de ene (1) stelschroef bovenop het kauwgomballenwiel los, die zich naast elke kauwgomballenholte bevindt. Draaien. het afstelwiel om de opening aan te passen aan het geventileerde product. De veren op de kauwgomballenborstelplaat moeten naar het muntmechanisme of de voorkant van de verkoper gericht zijn.

2. Munten ophalen:

Open de muntautomaat met de sleutel en haal de munten eruit

Let op: niet voorbij draai het slot vast, aangezien alleen een goede pasvorm nodig is.

Als u vragen heeft over ons product, neem dan contact op met onze klantenservice; Bedankt!

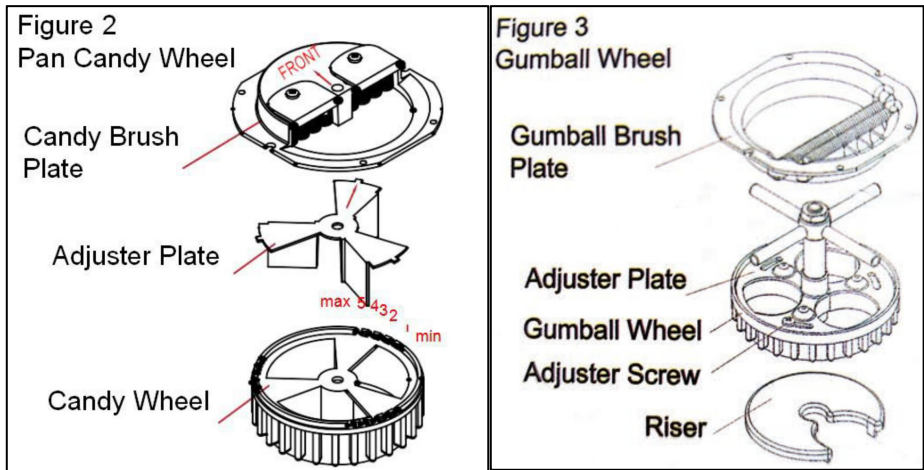

Schoonmaak

-Reinig de snoeppot regelmatig met een zachte doek en verwijder de munten uit het lichaam

Fabrikant: Shanghaimuxinmuyeyouxiangongsi

Adres: Baoshanqu Shuangchenglu 803lang 11hao 1602A-1609shi
Sjanghai

Geïmporteerd naar AUS: SIHAO PTY LTD.1 ROKEVA
STRAATSTEASTHOUT
NSW 2122 Australië

Geïmporteerd naar VS: Sanven Technologie Ltd. Suite 250.9166
Anaheim
Plaats, Rancho Cucamonga,CA91730



Pooledas Group Ltd
Unit 5 Albert Edward House,
The Pavilions Preston, United Kingdom
pooledas123@gmail.com
01772418127



SHUNSHUN GmbH
Römeräcker 9 Z2021,76351
Linkenheim-Hochstetten, Germany
euvertreter@gmail.com
+49 1727041930

VEVOR[®]

TOUGH TOOLS, HALF PRICE

Ondersteuning en e-garantiecertificaat

www.vevor.com/support

VEVOR[®]

TOUGH TOOLS, HALF PRICE

Teknisk Support och e-garanticertifikat www.vevor.com/support

Godisautomat _

We continue to be committed to provide you tools with competitive price.

"Save Half", "Half Price" or any other similar expressions used by us only represents an estimate of savings you might benefit from buying certain tools with us compared to the major top brands and does not necessarily mean to cover all categories of tools offered by us. You are kindly reminded to verify carefully when you are placing an order with us if you are actually saving half in comparison with the top major brands.

VEVOR®

TOUGH TOOLS, HALF PRICE

Candy Vending Machine

MODELL: AK19-08 MODELL: AK29-11

(RÖD / GUL / SVART) (BLÅ)



NEED HELP? CONTACT US!

Have product questions? Need technical support? Please feel free to contact us:

Technical Support and E-Warranty Certificate
www.vevor.com/support

This is the original instruction, please read all manual instructions carefully before operating. VEVOR reserves a clear interpretation of our user manual. The appearance of the product shall be subject to the product you received. Please forgive us that we won't inform you again if there are any technology or software updates on our product.

PRODUKTPARAMETRAR

Produktnamn : _ _ _	Godisautomat	
Modell:	Ak19-08	ak29-11
Produktstorlek : _	210x200x430 mm	215x200x410mm
P roduktfärg : _ _	Röd / Gul / Svart Tre typer	Blå
Godislåda:	3 st	4 st
Godiskapacitet:	Ca 8LBS / godislåda	
Gumbalkapacitet:	Cirka 320 av 1" tuggummibollar / godislåda	
Mynttyp:	Tjugofem cent	

ANVÄND FÖRSIKTIGHETSÅTGÄRDER



VARNING:

1. varuautomater är konstruerade för att fungera med 0,9-1,3 tums tuggummi/litet vridet ägg/single force ball. Kapslar eller bollar av olika storlekar fungerar inte med denna maskin.
2. Använd en ren trasa för att rengöra sockerbehållaren innan du håller upp godiset;
3. Dra inte våldsamt när du använder den.
4. Ställ in godis inom de parametrar som beskrivs i specifikationen.
5. Ställ inte produkten utomhus för att undvika regn.

SPARA DESSA INSTRUKTIONER

Produkt introduktion

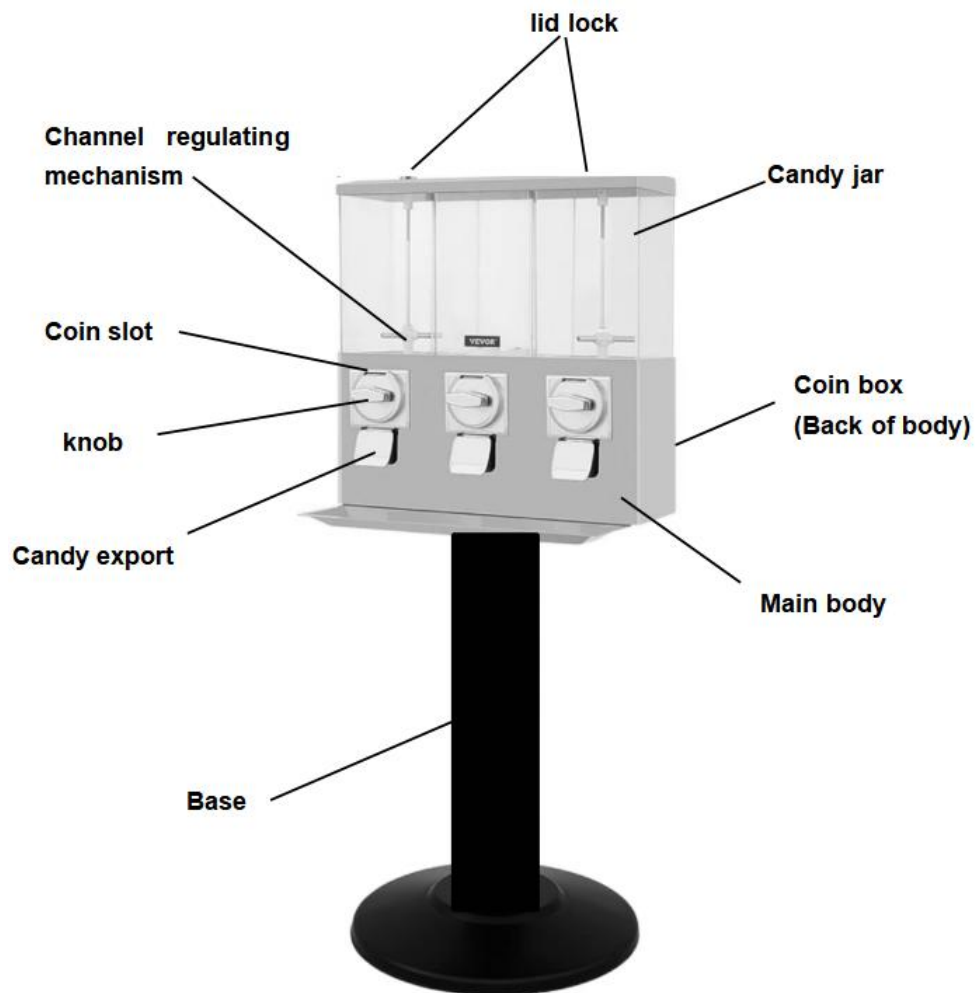

Modell: AK19-08

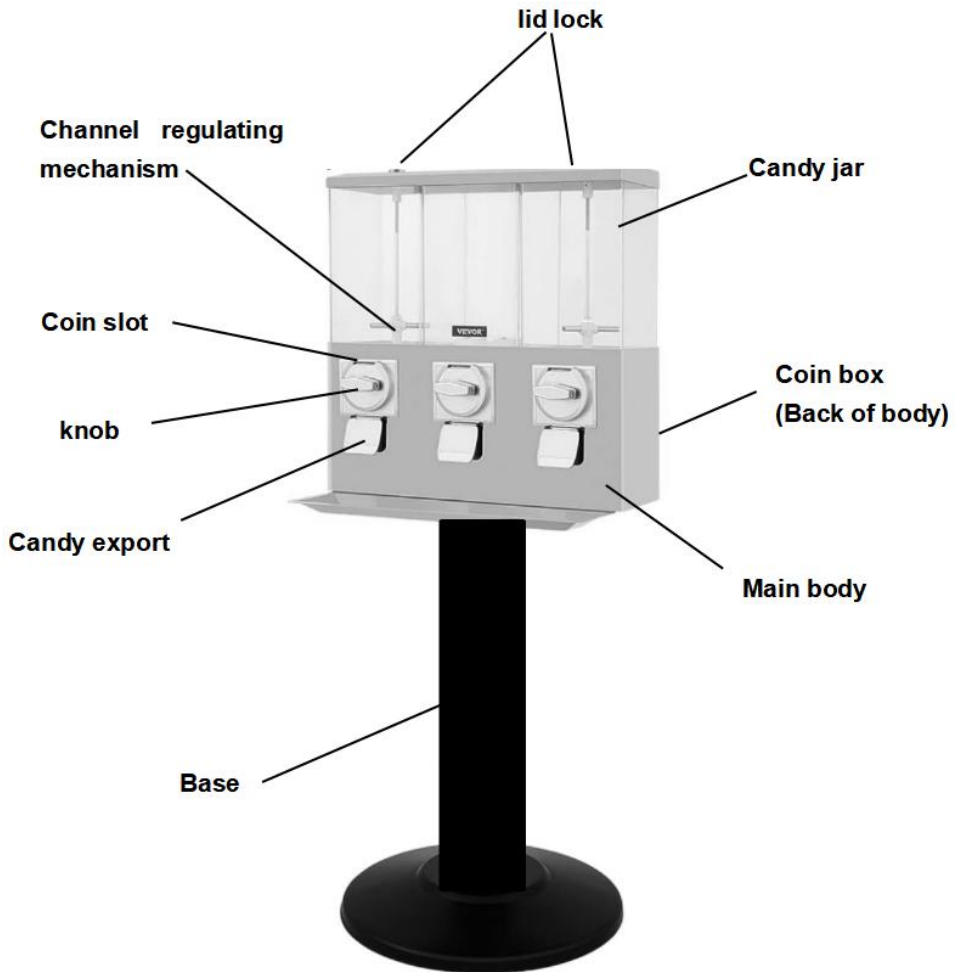

Modell: AK29-11

Användarguide

1. Inställning av godisgång

- A) Lås upp och öppna klotlocket genom att skruva av låset.
- B) Ta bort två stolpskruvar som håller fast jordklotet på behållaren.
- C) Ta bort godisborstplattan från behållaren
- D) Lyft upp justerplattan och flytta till önskat hjulinställningsskåra (fig.2).

Rengöring

-Rengör godisburken regelbundet med en mjuk trasa och ta bort mynten inuti kroppen

Tillverkare: Shanghaimuxinmuyeyouxiangongsi

Adress: Baoshanqu Shuangchenglu 803 lång 11hao 1602A-1609shi
Shanghai

Importerad till AUS: SIHAO PTY LTD.1 ROKEVA STREETEASTWOOD
NSW 2122 Australien

Importerad till USA: Sanven Teknologi Ltd. Svit 250,9166 Anaheim
Plats, Rancho Cucamonga, CA91730



Pooledas Group Ltd

Unit 5 Albert Edward House,

The Pavilions Preston, United Kingdom

pooledas123@gmail.com

01772418127



SHUNSHUN GmbH

Römeräcker 9 Z2021,76351

Linkenheim-Hochstetten, Germany

euvertreter@gmail.com

+49 1727041930

VEVOR[®]

TOUGH TOOLS, HALF PRICE

Support och e-garanticertifikat

www.vevor.com/support