

# VEVOR

**Upgrade · The Home Creator Way**

## **WALL MOULDING TRIM**

**MODEL: JX36#-L2438/JX88#-L2690/JX88#-L2165/  
JX36#-L1920/JX60#-L3842/JX88#-L1920/  
JC956#-JC960-L2044**



Model:JX36#-L2438

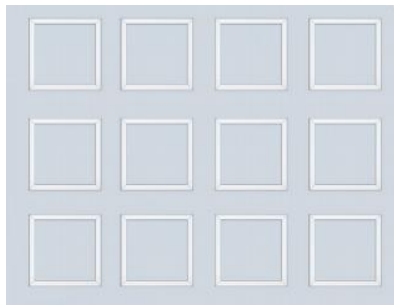

Model:JX88#-L2690

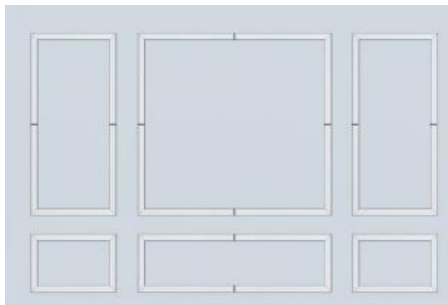

Model:JX88#-L2165

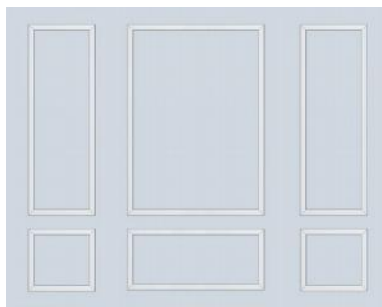

Model:JC956#-JC960-L2044

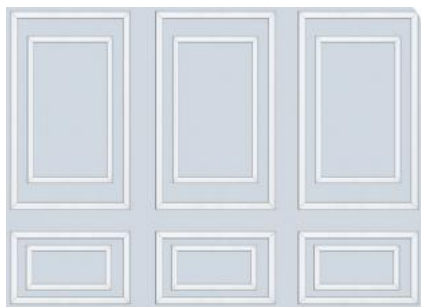

Model:JX36#-L1920

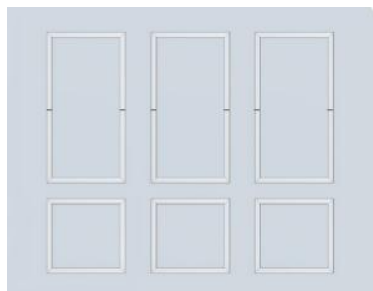

Model:JX60#-L3842

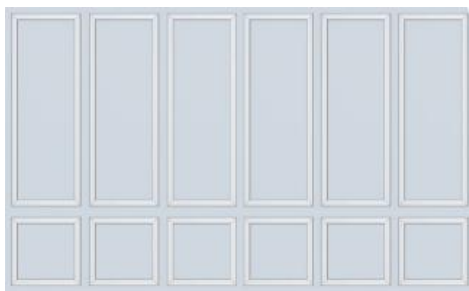

Model:JX88#-L1920

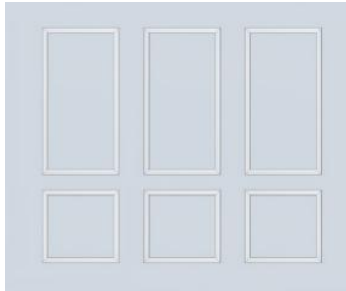

This is the original instruction, please read all manual instructions carefully before operating. VEVOR reserves a clear interpretation of our user manual. The appearance of the product shall be subject to the product you received. Please forgive us that we won't inform you again if there are any technology or software updates on our product.









Warning-To reduce the risk of injury, user must read instructions manual carefully.

## **WALL MOULDINGDIMENSIONS**



Measure your wall before ordering to ensure correct amount ordered



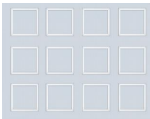
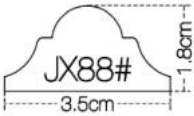
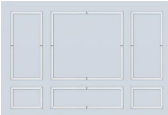
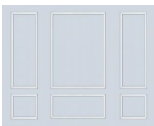

Thank you very much for choosing this Wall Moulding Trim . Please read all of the instructions before using it.The information will help you achieve the best possible results.

## TOOLS REQUIREMENT INTRODUCTION

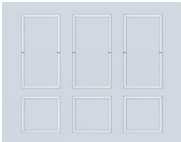
|   |   |   |
|---|---|---|
|  |  |  |
| Construction Adhesive   | Tape Measure  | Pencil  |
|  |  |  |
| Towel   | Marking Tape  | Gloves  |

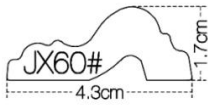
## SAVE THIS MANUAL

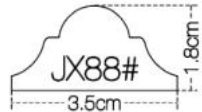
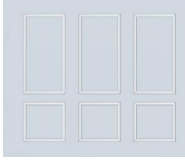
| Model       | Strip pattern   | Collage effect  |
|-------------|---|---|
| JX36#-L2438 |    |   |
| JX88#-L2690 |  |  |
| JX88#-L2165 |   |  |
| JX36#-L1920 |  |  |

|                    |   |   |
|--------------------|---|---|
| JX60#-L3842        |   |   |
| JX88#-L1920        |  |  |
| JC956#-JC960-L2044 |  |  |

## BEFORE INSTALLATION: FOUNDATION PREPARATION

### **Wall condition inspection: Ensure that the "base is qualified"**

The installation of decorative strips relies on flat, dry, and sturdy walls, and needs to be checked one by one in the early stage:

**Flatness:** Use a 2-meter ruler to test the wall surface, with an error of  $\leq 3\text{mm}$ . If there are protrusions, depressions, or cracks on the wall surface, apply putty to level it first (it is recommended to use water-resistant putty, especially in damp areas such as bathrooms and kitchens). After drying, use sandpaper to polish it smooth.

**Drying degree:** The new wall surface should be completely dry (it is recommended to ventilate for at least 7 days after painting latex paint walls, and maintain for 28 days for cement walls), to avoid moisture regain on the wall surface in the later stage, which may cause the decorative strips to fall off or mold.

**Cleanliness:** Remove dust, oil stains, and floating ash from the wall surface. Use a damp cloth to wipe and air dry to prevent a decrease in adhesive adhesion.

## INSTALLATION STEPS

### JX36#-L2438

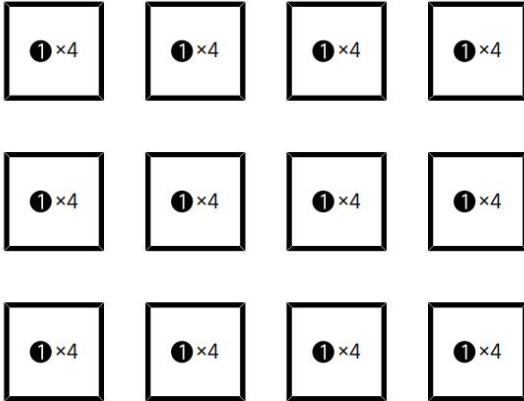

 20"  
 48 Pieces

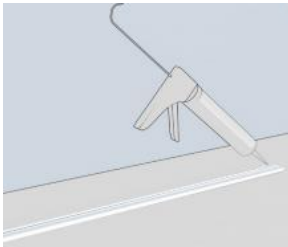
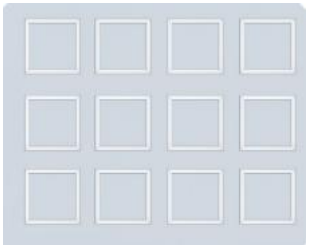
|  |   |   |
|--|---|---|
|                      |  |   |
| <p>Step 1: After measuring the dimensions, use a pencil and ruler to mark the correct positions.</p> | <p>Step 2: Apply construction adhesive to the back of the molding trims.</p>      | <p>Step 3: Attach them to the wall according to their numbers. Use tape to hold them in place until the adhesive cures.</p> |

## JX88#-L2690

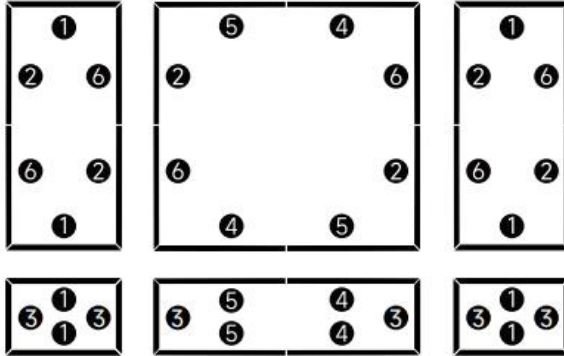

**1** 31"

8 Pieces



**2** 31.5"

6 Pieces



**3** 24"

6 Pieces



**4** 36"

4 Pieces



**5** 36"

4 Pieces



**6** 31.5"

6 Pieces



Step 1: After measuring the dimensions, use a pencil and ruler to mark the correct positions.

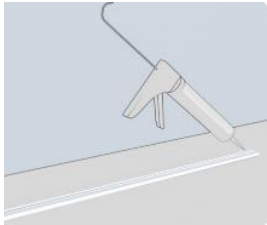

Step 2: Apply construction adhesive to the back of the molding trims.

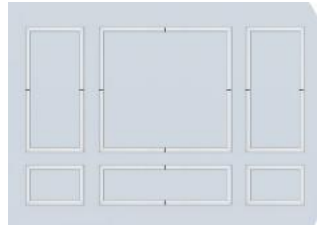

Step 3: Attach them to the wall according to their numbers. Use tape to hold them in place until the adhesive cures.

**JX88#-L2165**

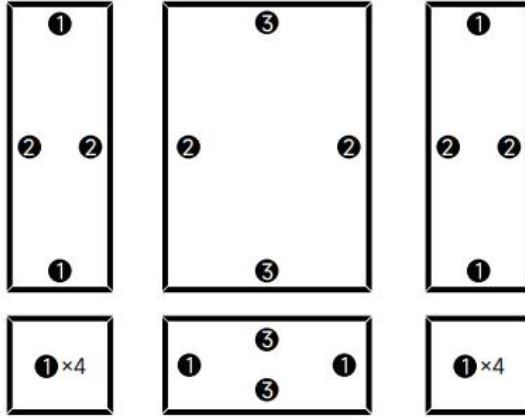

**1** 23"  
14 Pieces



**2** 56.3"  
6 Pieces



**3** 48"  
4 Pieces

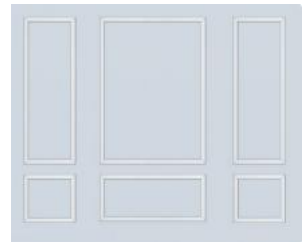
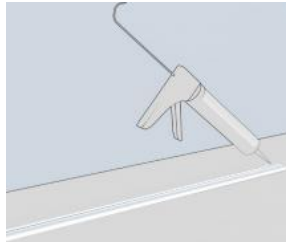
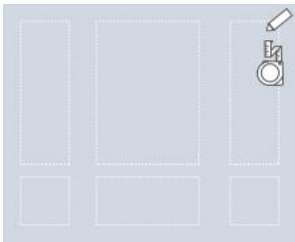

Step 1: After measuring the dimensions, use a pencil and ruler to mark the correct positions.

Step 2: Apply construction adhesive to the back of the molding trims.

Step 3: Attach them to the wall according to their numbers. Use tape to hold them in place until the adhesive cures.

## JX36#-L1920

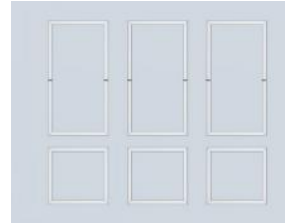
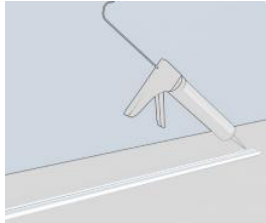
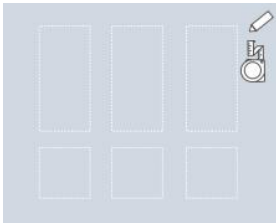
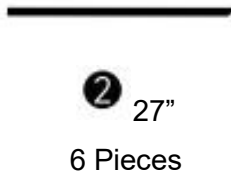
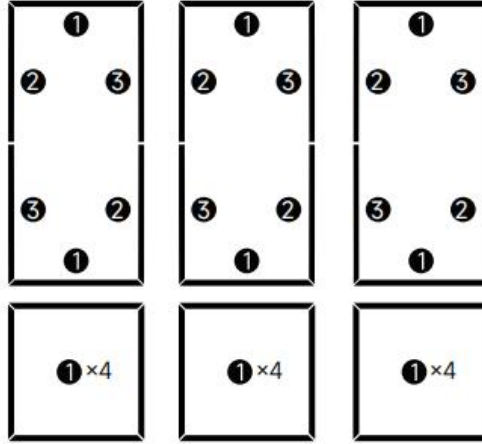

Step 1: After measuring the dimensions, use a pencil and ruler to mark the correct positions.

Step 2: Apply construction adhesive to the back of the molding trims.

Step 3: Attach them to the wall according to their numbers. Use tape to hold them in place until the adhesive cures.

JX60#-L3842

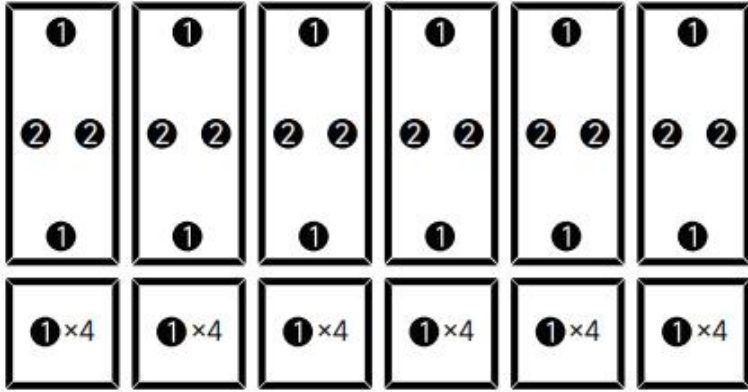

1 24"

36 Pieces



2 54"

12 Pieces

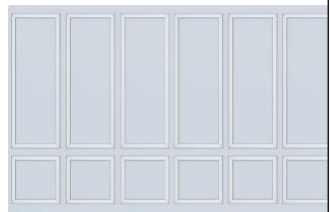
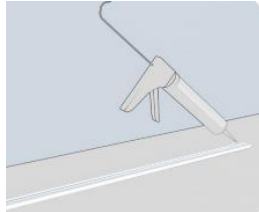

Step 1: After measuring the dimensions, use a pencil and ruler to mark the correct positions.

Step 2: Apply construction adhesive to the back of the molding trims.

Step 3: Attach them to the wall according to their numbers. Use tape to hold them in place until the adhesive cures.

**JX88#-L1920**

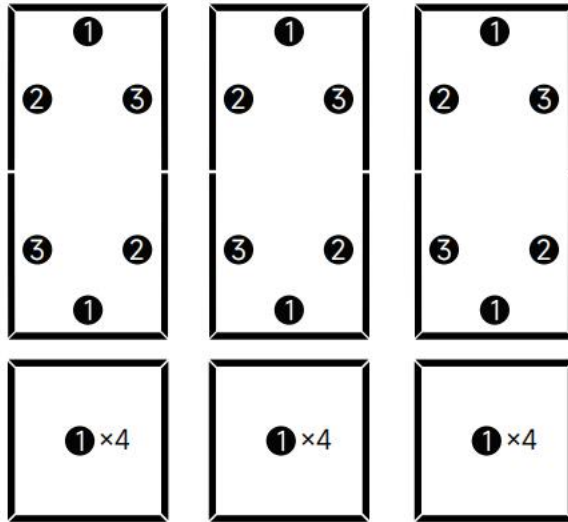

**1** 24"

18 Pieces



**2** 27"

6 Pieces



**3** 27"

6 Pieces

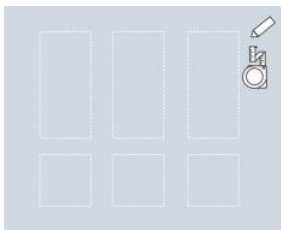

Step 1: After measuring the dimensions, use a pencil and ruler to mark the correct positions.

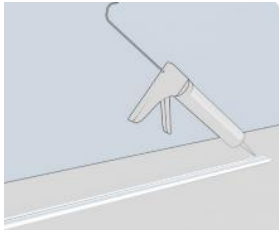

Step 2: Apply construction adhesive to the back of the molding trims.

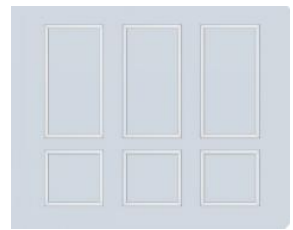

Step 3: Attach them to the wall according to their numbers. Use tape to hold them in place until the adhesive cures.

JC956#-JC960-L2044

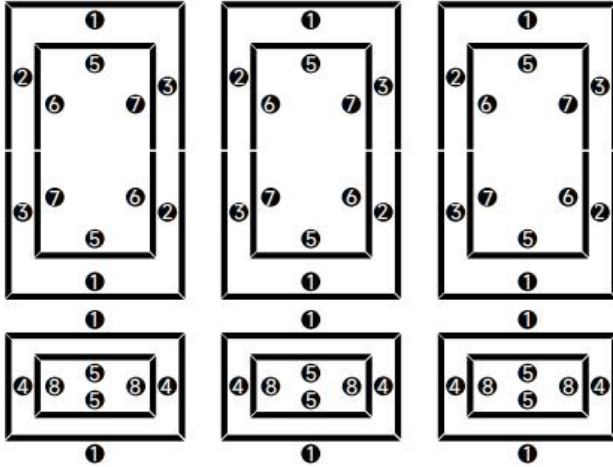

**1** 31"

12 Pieces



**2** 27"

6 Pieces



**3** 27"

6 Pieces



**4** 18"

6 Pieces



**5** 19"

12 Pieces



**6** 19"

6 Pieces



**7** 19"

6 Pieces



**8** 6"

6 Pieces

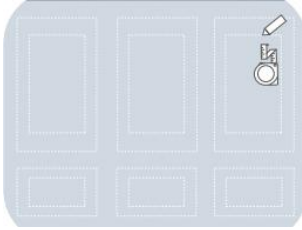
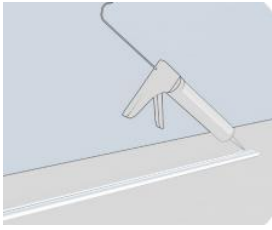
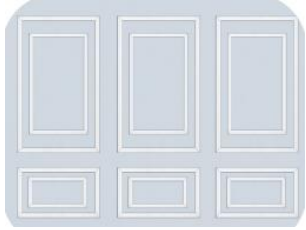
|  |  |   |
|--|--|---|
|                       |  |    |
| <p>Step 1: After measuring the dimensions, use a pencil and ruler to mark the correct positions.</p> | <p>Step 2: Apply construction adhesive to the back of the molding trims.</p>     | <p>Step 3: Attach them to the wall according to their numbers. Use tape to hold them in place until the adhesive cures.</p> |

## SUMMARY

The core of installing wall decorative strips is "pre measurement, mid-term fixation, and later repair". It is necessary to match the wall conditions and tools according to the material of the decorative strips, especially paying attention to details such as internal and external corner splicing and adhesive selection, in order to achieve a "smooth, seamless, firm and durable" decorative effect and avoid rework or aesthetic decline due to improper operation.

**Manufacturer:** Shanghaimuxinmuyeyouxiangongsi

**Address:** Shuangchenglu 803nong11hao1602A-1609shi, baoshanqu, shanghai 200000 CN.

**Imported to AUS:** SIHAO PTY LTD. 1 ROKEVA STREETEASTWOOD NSW 2122 Australia

**Imported to USA:** Sanven Technology Ltd. Suite 250, 9166 Anaheim Place, Rancho Cucamonga, CA 91730

|           |            |
|-----------|------------|
| <b>UK</b> | <b>REP</b> |
|-----------|------------|

YH CONSULTING LIMITED. C/O YH Consulting Limited Office 147, Centurion House, London Road, Staines-upon-Thames, Surrey, TW18 4AX

|           |            |
|-----------|------------|
| <b>EC</b> | <b>REP</b> |
|-----------|------------|

E-CrossStu GmbH  
Mainzer Landstr.69,  
60329 Frankfurt am Main.



# **VEVOR**

**Upgrade · The Home Creator Way**

## **MOULURES MURALES**

**MODÈLE : JX36#-L2438/JX88#-L2690/JX88#-L2165/  
JX36#-L1920/JX60#-L3842/JX88#-L1920/  
JC956#-JC960-L2044**



Modèle : JX36#-L2438

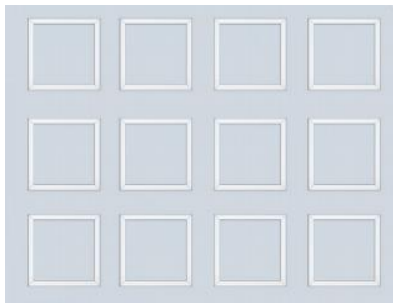

Modèle : JX88#-L2690

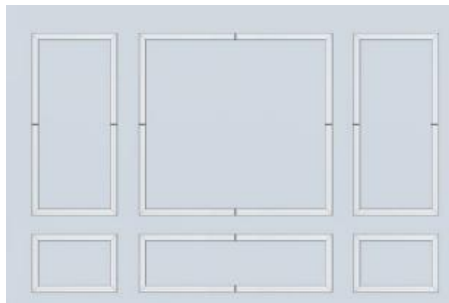

Modèle : JX88#-L2165

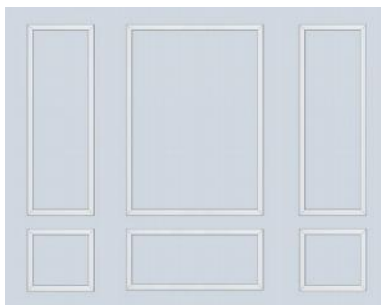

Modèle : JC956#-JC960-L2044

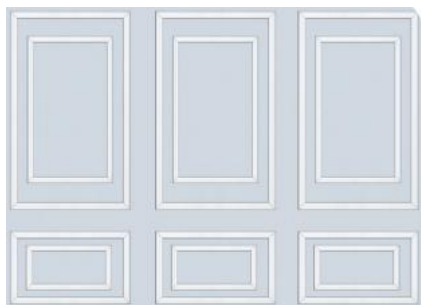

Modèle : JX36#-L1920

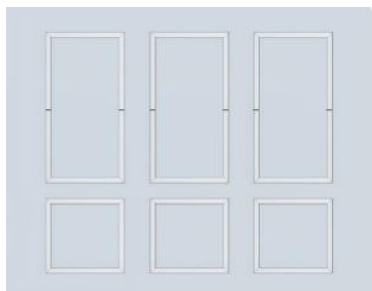

Modèle : JX60#-L3842

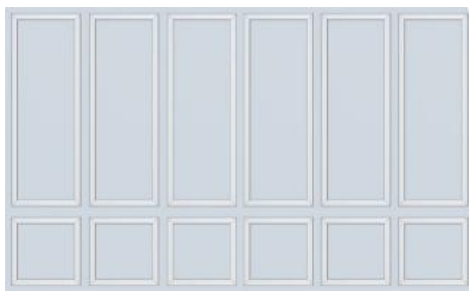

Modèle : JX88#-L1920

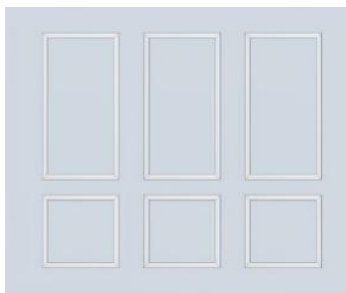

Voici le mode d'emploi original. Veuillez lire attentivement toutes les instructions du manuel avant utilisation. VEVOR se réserve le droit d'interpréter ce manuel à sa guise. L'apparence du produit que vous recevrez peut différer. Nous vous prions de nous excuser si nous ne vous informons pas des mises à jour techniques ou logicielles concernant notre produit.









Avertissement – Afin de réduire les risques de blessure, l'utilisateur doit lire attentivement le manuel d'instructions.

## **DIMENSIONS DES MOULURES MURALES**



Mesurez votre mur avant de commander. pour garantir la quantité correcte commandée

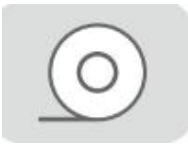

Merci d'avoir choisi cette moulure murale. Veuillez lire attentivement toutes les instructions avant utilisation. Ces informations vous permettront d'obtenir un résultat optimal.

## TOOLS REQUIREMENT INTRODUCTION

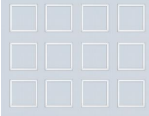
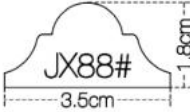
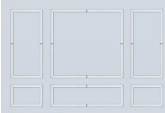
|   |   |   |
|---|---|---|
|  |  |  |
| Construction<br>Adhésif   | Mètre à ruban   | Crayon  |
|  |  |  |
| Serviette   | Ruban de marquage   | Gants   |

## SAVE THIS MANUAL

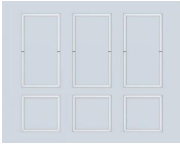
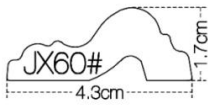
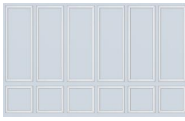
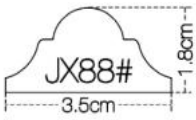
| Modèle      | Motif à rayures   | Effet collage   |
|-------------|---|---|
| JX36#-L2438 |   |   |
| JX88#-L2690 |  |  |
| JX88#-L2165 |   |  |

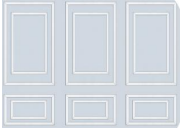
|                    |   |   |
|--------------------|---|---|
| JX36#-L1920        |  |   |
| JX60#-L3842        |  |  |
| JX88#-L1920        |  |  |
| JC956#-JC960-L2044 |  |  |

## BEFORE INSTALLATION: FOUNDATION PREPARATION

### Inspection de l'état des murs : s'assurer que la « base est qualifiée ».

La pose de baguettes décoratives nécessite des murs plats, secs et solides, et doit être vérifiée une par une au début du projet :

**Planéité :** Utilisez une règle de 2 mètres pour vérifier la planéité du mur, avec une marge d'erreur de 3 mm maximum. En cas de protubérances, de creux ou de fissures, appliquez d'abord un enduit de lissage (il est recommandé d'utiliser un enduit hydrofuge, notamment dans les pièces humides comme les salles de bains et les cuisines). Après séchage, poncez pour obtenir une surface lisse.

**Degré de séchage :** La nouvelle surface du mur doit être complètement sèche (il est recommandé de ventiler pendant au moins 7 jours après l'application d'une peinture au latex sur les murs, et de maintenir cette ventilation pendant 28 jours pour les murs en ciment), afin d'éviter une

réapparition d'humidité sur la surface du mur ultérieurement, ce qui pourrait entraîner le décolllement des bandes décoratives ou la formation de moisissures.

Nettoyage : Enlevez la poussière, les taches d'huile et les cendres en suspension sur la surface du mur. Essuyez avec un chiffon humide et laissez sécher à l'air libre pour éviter une diminution de l'adhérence de la colle.

## INSTALLATION STEPS



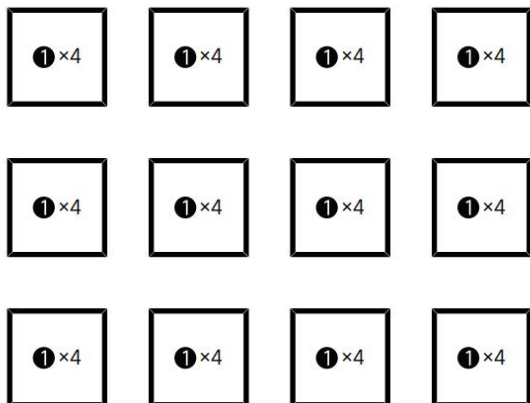



### JX36#-L2438







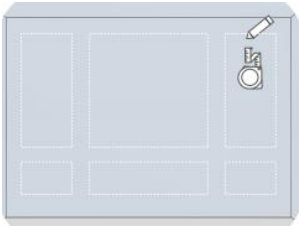
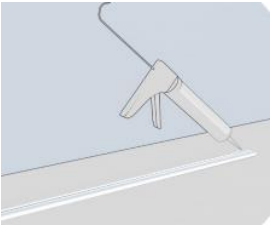
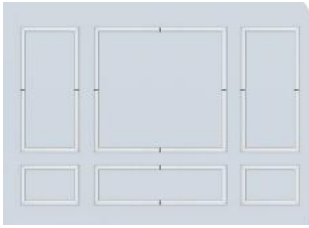

**1** 20 pouces  
48 pièces

|   |  |   |
|---|--|---|
|   |  |   |
| <p>Étape 1 : Après avoir mesuré les dimensions, utilisez un crayon et</p> | <p>Étape 2 : Appliquez de la colle de construction à</p> | <p>Étape 3 : Fixez-les au mur en suivant leur numéro. Utilisez du</p> |



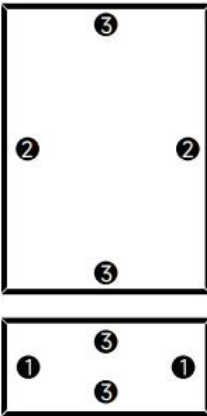
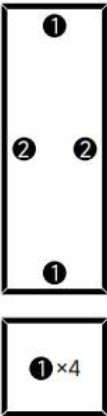

|  |                                 |   |
|--|---------------------------------|---|
| <p>une règle pour marquer les positions correctes.</p> | <p>l'arrière des moulures .</p> | <p>ruban adhésif pour les maintenir en place jusqu'à ce que la colle sèche.</p> |
|--|---------------------------------|---|

| <p align="center"><b>JX88#-L2690</b></p>   |  |  |
|--|--|--|
|  |  |  |
|  <p><b>1</b> 31<br/>8 pièces</p>          |  <p><b>2</b> 31,5 pouces<br/>6 pièces</p> |  <p><b>3</b> 24 pouces<br/>6 pièces</p>     |
|  <p><b>4</b> 36 pouces<br/>4 pièces</p> |  <p><b>5</b> 36 pouces<br/>4 pièces</p> |  <p><b>6</b> 31,5 pouces<br/>6 pièces</p> |

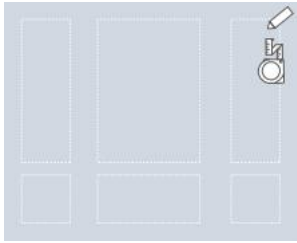
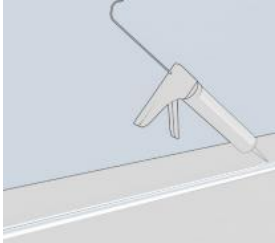
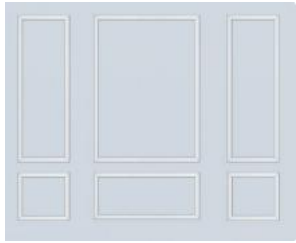

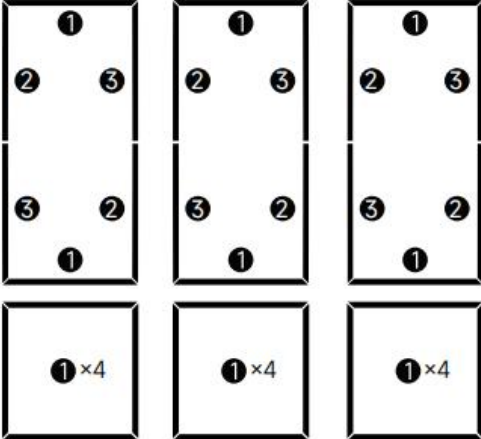
|   |   |  |
|---|---|--|
|    |   |   |
| <p>Étape 1 : Après avoir mesuré les dimensions, utilisez un crayon et une règle pour marquer les positions correctes.</p> | <p>Étape 2 : Appliquez de la colle de construction à l'arrière des moulures .</p> | <p>Étape 3 : Fixez-les au mur en suivant leur numéro. Utilisez du ruban adhésif pour les maintenir en place jusqu'à ce que la colle sèche.</p> |

| <b>JX88#-L2165</b>  |  |  |
|---|--|--|
|   |    |    |
|  <p><b>1</b> 23 pouces<br/>14 pièces</p> |  <p><b>2</b> 56,3 pouces<br/>6 pièces</p> |  <p><b>3</b> 48 pouces<br/>4 pièces</p> |

|   |  |   |
|---|--|---|
|    |  |    |
| <p>Étape 1 : Après avoir mesuré les dimensions, utilisez un crayon et une règle pour marquer les positions correctes.</p> | <p>Étape 2 : Appliquez de la colle de construction à l'arrière des moulures.</p> | <p>Étape 3 : Fixez-les au mur en suivant leur numéro. Utilisez du ruban adhésif pour les maintenir en place jusqu' à ce que la colle sèche.</p> |

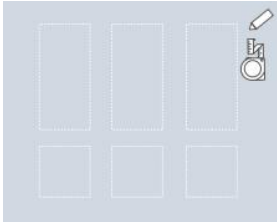
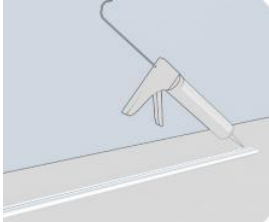
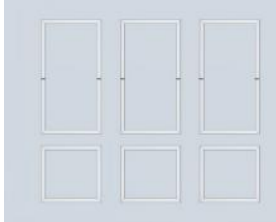

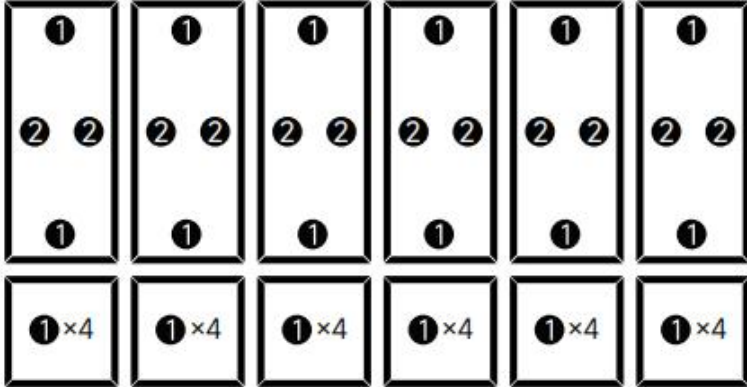
|  |   |   |
|--|---|---|
| <b>JX36#-L1920</b>   |   |   |
|    |   |   |
|  <p><b>1</b> 24<br/>pouces<br/>18 pièces</p> |  <p><b>2</b> 27 pouces</p> |  <p><b>3</b> 27 pouces</p> |

|   | 6 pièces  | 6 pièces   |
|---|---|--|
|    |  |    |
| <p>Étape 1 : Après avoir mesuré les dimensions, utilisez un crayon et une règle pour marquer les positions correctes.</p> | <p>Étape 2 : Appliquez de la colle de construction à l'arrière des moulures.</p>  | <p>Étape 3 : Fixez-les au mur en suivant leur numéro. Utilisez du ruban adhésif pour les maintenir en place jusqu'à ce que la colle sèche.</p> |

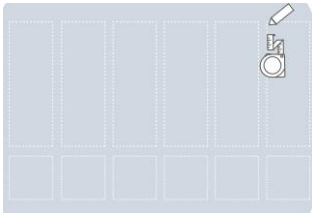
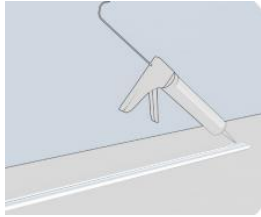
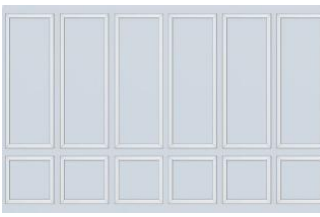
| JX60#-L3842   |   |  |
|---|---|--|
|                                       |   |  |
|  <p>1 24<br/>pouces<br/>36 pièces</p> |  <p>2 54 "<br/>12 pièces</p> |  |

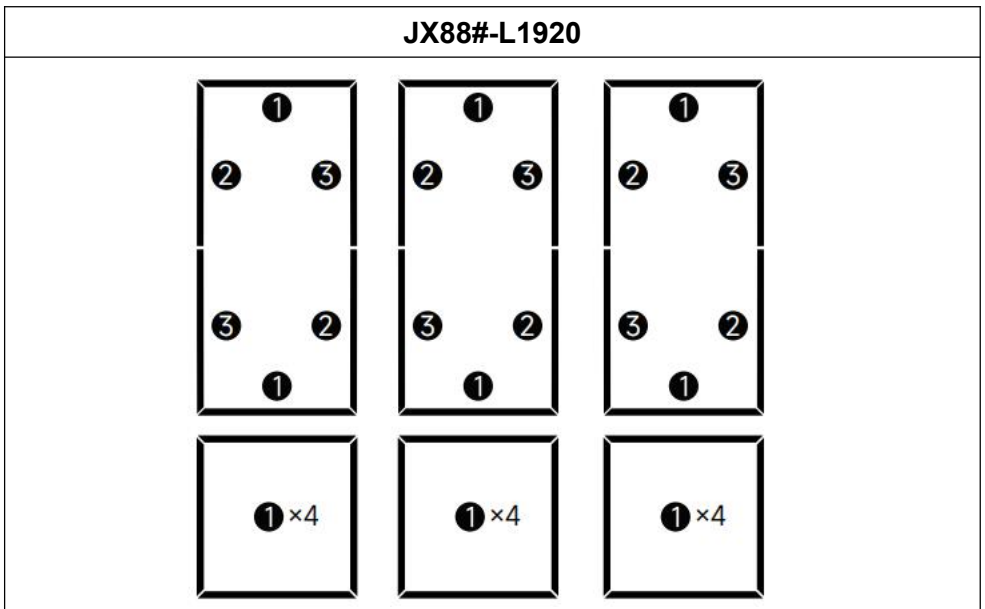



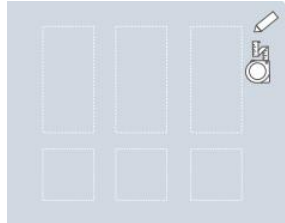
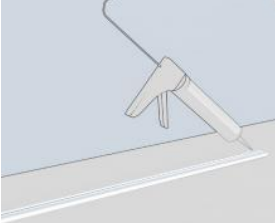
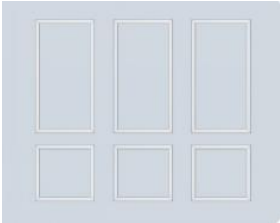

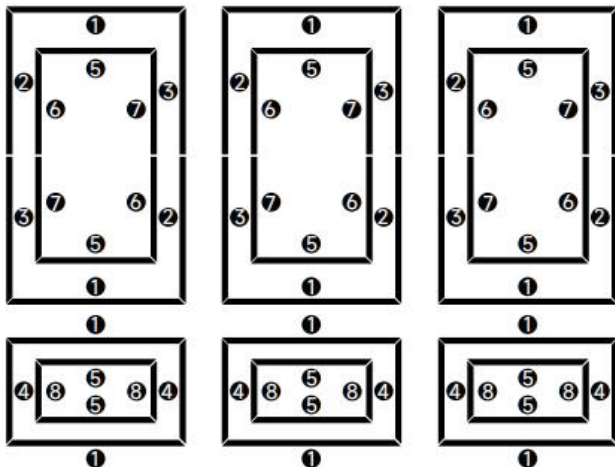

|   |  |  |
|---|--|--|
|    |  |   |
| <p>Étape 1 : Après avoir mesuré les dimensions, utilisez un crayon et une règle pour marquer les positions correctes.</p> | <p>Étape 2 : Appliquez de la colle de construction à l'arrière des moulures.</p> | <p>Étape 3 : Fixez-les au mur en suivant leur numéro. Utilisez du ruban adhésif pour les maintenir en place jusqu'à ce que la colle sèche.</p> |



|   |   |  |
|---|---|--|
|  <p>24<br/>pouces<br/>18 pièces</p>       |  <p>27 pouces<br/>6 pièces</p> |  <p>27 pouces<br/>6 pièces</p>                                |
|   |                                |    |
| <p>Étape 1 : Après avoir mesuré les dimensions, utilisez un crayon et une règle pour marquer les positions correctes.</p> | <p>Étape 2 : Appliquez de la colle de construction à l'arrière des moulures.</p>                                | <p>Étape 3 : Fixez-les au mur en suivant leur numéro. Utilisez du ruban adhésif pour les maintenir en place jusqu'à ce que la colle sèche.</p> |

JC956#-JC960-L2044

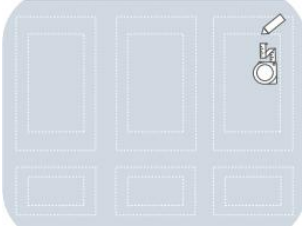
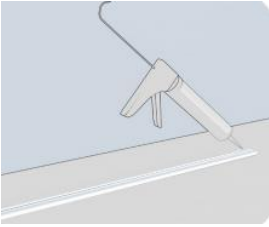
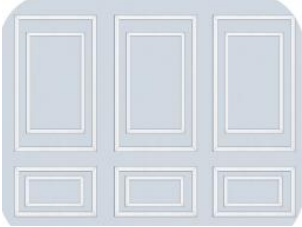

|   |   |  |
|---|---|--|
|  <p><b>1</b> 31<br/>12 pièces</p>         |  <p><b>2</b> 27 pouces<br/>6 pièces</p> |  <p><b>3</b> 27 pouces<br/>6 pièces</p>                        |
|  <p><b>4</b> 18 pouces<br/>6 pièces</p>  |  <p><b>5</b> 19"<br/>12 pièces</p>     |  <p><b>6</b> 19"<br/>6 pièces</p>                             |
|  <p><b>7</b> 19"<br/>6 pièces</p>        |  <p><b>8</b> 6 pouces<br/>6 pièces</p> |  |
|   |                                        |    |
| <p>Étape 1 : Après avoir mesuré les dimensions, utilisez un crayon et une règle pour marquer les positions correctes.</p> | <p>Étape 2 : Appliquez de la colle de construction à l'arrière des moulures .</p>                                       | <p>Étape 3 : Fixez-les au mur en suivant leur numéro. Utilisez du ruban adhésif pour les maintenir en place jusqu'à ce que la colle sèche.</p> |

## SUMMARY

La pose de baguettes décoratives murales repose sur trois étapes essentielles : la prise de mesures préalables, la fixation provisoire et les

réparations ultérieures. Il est indispensable d'adapter les outils et les caractéristiques du mur au matériau des baguettes, en portant une attention particulière aux détails tels que les raccords d'angle (intérieurs et extérieurs) et le choix de la colle, afin d'obtenir un résultat esthétique harmonieux, uniforme et durable, et d'éviter les retouches ou une dégradation du rendu due à une mauvaise application.

**Fabricant** : Shanghaimuxinmuyeyouxiangongsi

**Adresse** : Shuangchenglu 803nong11hao1602A-1609shi, baoshanqu, Shanghai 200000 CN.

**Importé en Australie** : SIHAO PTY LTD. 1 ROKEVA  
STREETEASTWOOD  
NSW 2122 Australie

**Importé aux États-Unis** : Sanven Technology Ltd., Suite 250, 9166  
Anaheim  
Rancho Cucamonga, CA 91730

|           |            |
|-----------|------------|
| <b>UK</b> | <b>REP</b> |
|-----------|------------|

YH CONSULTING LIMITED. C/O YH Consulting  
Limited Office 147, Centurion House, London  
Road, Staines-upon-Thames, Surrey, TW18 4AX

|           |            |
|-----------|------------|
| <b>EC</b> | <b>REP</b> |
|-----------|------------|

E-CrossStu GmbH  
Mainzer Landstr.69,  
60329 Frankfurt am Main.





# **VEVOR**

**Upgrade · The Home Creator Way**

## **WANDLEISTENLEISTE**

**MODELL: JX36#-L2438/JX88#-L2690/JX88#-L2165/  
JX36#-L1920/JX60#-L3842/JX88#-L1920/  
JC956#-JC960-L2044**



Modell: JX36#-L2438

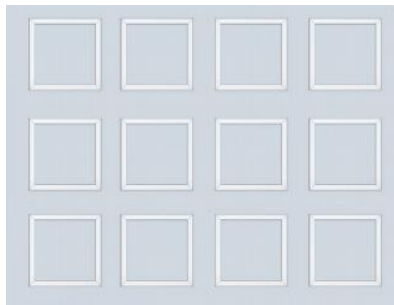

Modell: JX88#-L2690

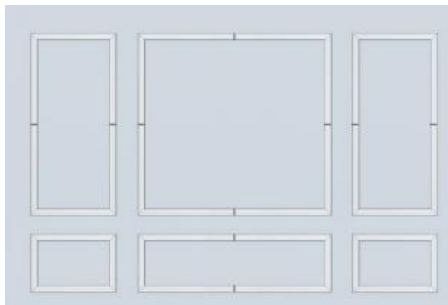

Modell: JX88#-L2165

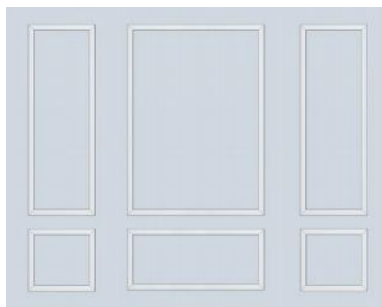

Modell: JC956#-JC960-L2044

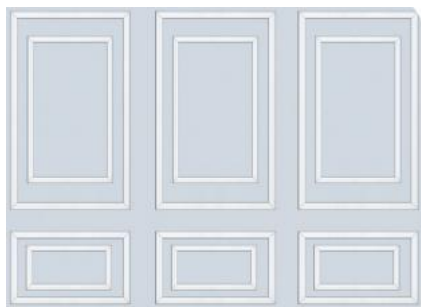

Modell: JX36#-L1920

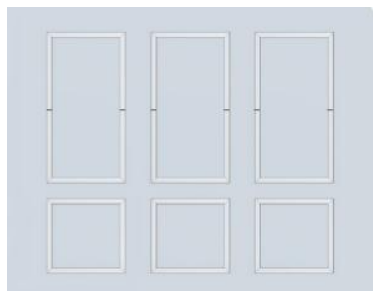

Modell: JX60#-L3842

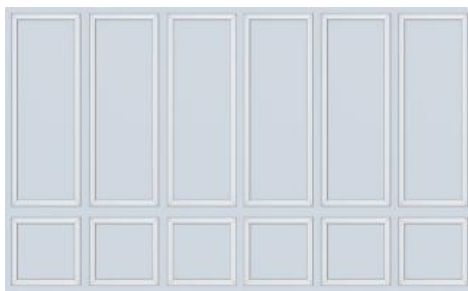

Modell: JX88#-L1920

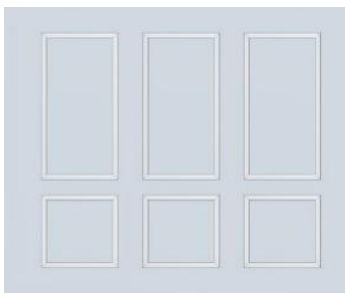

Dies ist die Originalanleitung. Bitte lesen Sie die gesamte Bedienungsanleitung vor der Inbetriebnahme sorgfältig durch. VEVOR behält sich die Auslegung der Bedienungsanleitung vor. Das Aussehen des Produkts kann von dem gelieferten Produkt abweichen. Wir bitten um Verständnis, dass wir Sie nicht erneut über etwaige Technologie- oder Software-Updates informieren werden .









Warnung – Um das Verletzungsrisiko zu verringern, muss der Benutzer die Bedienungsanleitung sorgfältig lesen.

### **Wandleistenabmessungen**



Messen Sie Ihre Wand vor der Bestellung aus, um sicherzustellen, dass die bestellte Menge korrekt ist

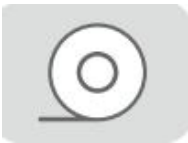

Vielen Dank, dass Sie sich für diese Wandleiste entschieden haben. Bitte lesen Sie die gesamte Anleitung vor der Anwendung sorgfältig durch. Die Informationen helfen Ihnen, optimale Ergebnisse zu erzielen.

## TOOLS REQUIREMENT INTRODUCTION

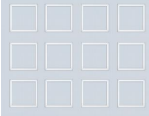
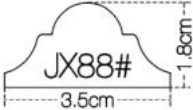
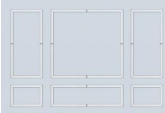
|   |   |   |
|---|---|---|
|  |  |  |
| Konstruktion<br>Klebstoff   | Bandmaß   | Bleistift   |
|  |  |  |
| Handtuch  | Markierungsband   | Handschuhe  |

## SAVE THIS MANUAL

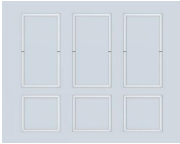
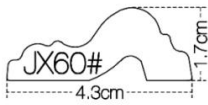
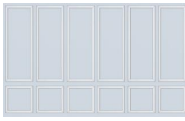
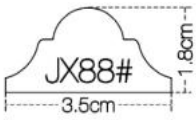
| Modell      | Streifenmuster  | Collage-Effekt  |
|-------------|---|---|
| JX36#-L2438 |   |   |
| JX88#-L2690 |  |  |
| JX88#-L2165 |   |  |

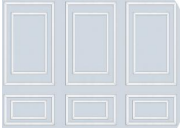
|                    |   |   |
|--------------------|---|---|
| JX36#-L1920        |  |   |
| JX60#-L3842        |  |  |
| JX88#-L1920        |  |  |
| JC956#-JC960-L2044 |  |  |

## BEFORE INSTALLATION: FOUNDATION PREPARATION

### **Zustandsprüfung der Wände: Sicherstellen, dass der „Fundamentzustand den Anforderungen entspricht“.**

Die Anbringung von Zierleisten erfordert ebene, trockene und stabile Wände und muss in der Anfangsphase einzeln überprüft werden:











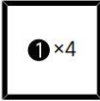

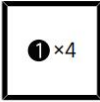

**Ebenheit:** Prüfen Sie die Wandoberfläche mit einem 2-Meter-Lineal auf Unebenheiten (Abweichung  $\leq 3$  mm). Falls die Wand Unebenheiten, Vertiefungen oder Risse aufweist, gleichen Sie diese zunächst mit Spachtelmasse aus (in Feuchträumen wie Badezimmern und Küchen empfiehlt sich wasserfeste Spachtelmasse). Nach dem Trocknen glätten Sie die Oberfläche mit Schleifpapier.

**Trocknungsgrad:** Die neue Wandoberfläche sollte vollständig trocken sein (es wird empfohlen, nach dem Streichen von Latexfarbenwänden mindestens 7 Tage lang zu lüften und bei Zementwänden 28 Tage lang),

um zu vermeiden, dass später erneut Feuchtigkeit an die Wandoberfläche gelangt, was zum Abfallen der Zierleisten oder zu Schimmelbildung führen kann.

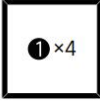
Reinigung: Entfernen Sie Staub, Ölflecken und Aschepartikel von der Wandoberfläche. Wischen Sie die Oberfläche mit einem feuchten Tuch ab und lassen Sie sie an der Luft trocknen, um die Haftung des Klebstoffs nicht zu beeinträchtigen.

## INSTALLATION STEPS

| JX36#-L2438   |   |   |   |   |
|---|---|---|---|---|
|  |  |  |  | <br> 20 Zoll<br>48 Stück |
|  |  |  |  |   |
|  |  |  |  |   |

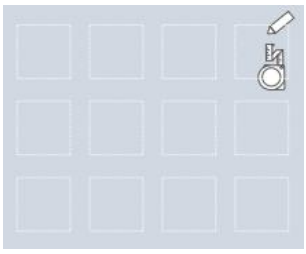
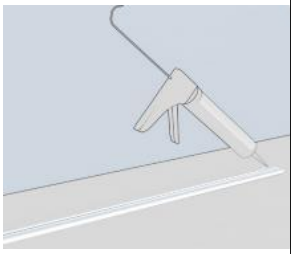
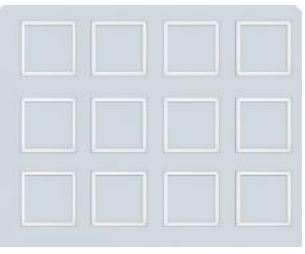
|  |   |  |
|--|---|--|
|  |  |  |
| Schritt 1: Nachdem Sie die Abmessungen gemessen haben,                             | Schritt 2: Tragen Sie Konstruktionskleber auf die Rückseite                         | Schritt 3: Befestigen Sie sie entsprechend ihrer Nummerierung an                     |

|   |                              |  |
|---|------------------------------|--|
| <p>markieren Sie die korrekten Positionen mit Bleistift und Lineal.</p> | <p>der Zierleisten auf .</p> | <p>der Wand. Fixieren Sie sie mit Klebeband, bis der Kleber ausgehärtet ist.</p> |
|---|------------------------------|--|

**JX88#-L2690**

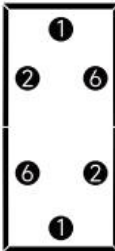
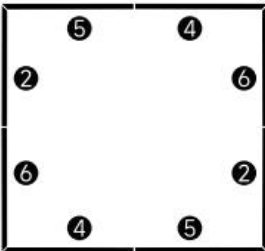
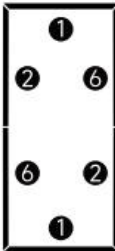







**1** 31 Zoll  
8 Stück



**2** 31,5 Zoll  
6 Stück



**3** 24 Zoll  
6 Stück



**4** 36 Zoll  
4 Stück









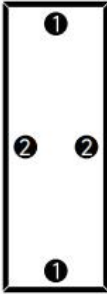
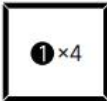
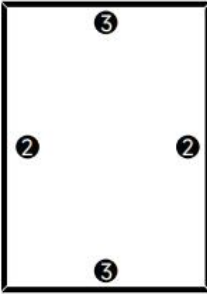

**5** 36 Zoll  
4 Stück

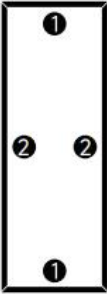
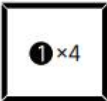



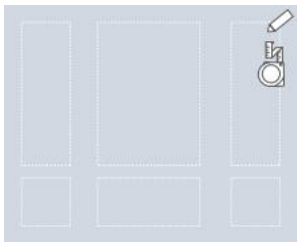
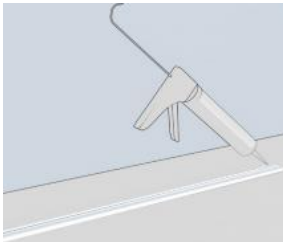

**6** 31,5 Zoll  
6 Stück

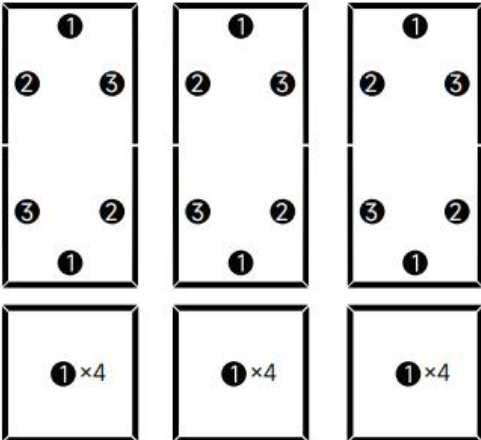

|  |  |   |
|--|--|---|
|   |          |    |
| <p>Schritt 1: Nachdem Sie die Abmessungen gemessen haben, markieren Sie die korrekten Positionen mit Bleistift und Lineal.</p> | <p>Schritt 2: Tragen Sie Konstruktionskleber auf die Rückseite der Zierleisten auf .</p> | <p>Schritt 3: Befestigen Sie sie entsprechend ihrer Nummerierung an der Wand. Fixieren Sie sie mit Klebeband, bis der Kleber ausgehärtet ist.</p> |

| <b>JX88#-L2165</b>  |   |   |
|---|---|---|
| <br> | <br> | <br> |
|  <p><b>1</b> 23 Zoll<br/>14 Stück</p>  |  <p><b>2</b> 56,3 Zoll<br/>6 Stück</p>   |  <p><b>3</b> 48 Zoll<br/>4 Stück</p>   |

|  |   |  |
|--|---|--|
|   |         |   |
| <p>Schritt 1: Nachdem Sie die Abmessungen gemessen haben, markieren Sie die korrekten Positionen mit Bleistift und Lineal.</p> | <p>Schritt 2: Tragen Sie Konstruktionskleber auf die Rückseite der Zierleisten auf.</p> | <p>Schritt 3: Befestigen Sie die Teile entsprechend ihrer Nummerierung an der Wand. Fixieren Sie sie mit Klebeband, bis der Klebstoff ausgehärtet ist.</p> |

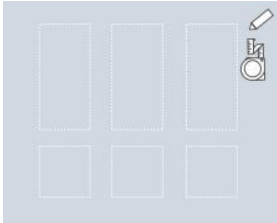
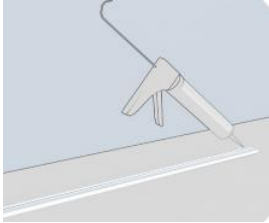
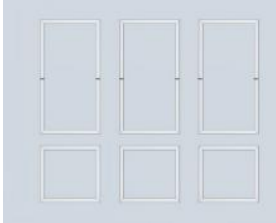
|   |   |   |
|---|---|---|
| <p><b>JX36#-L1920</b></p>   |   |   |
|   |   |   |
|  <p><b>1</b> 24<br/>Zoll<br/>18 Stück</p> |  <p><b>2</b> 27 Zoll</p> |  <p><b>3</b> 27 Zoll</p> |

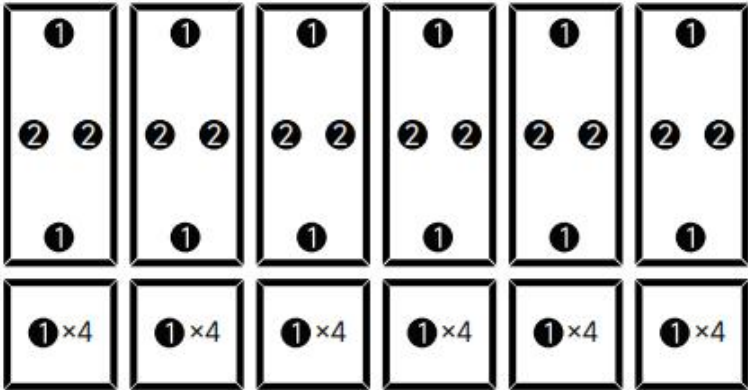
|   | 6 Stück   | 6 Stück   |
|---|---|---|
|                                        |  |   |
| Schritt 1: Nachdem Sie die Abmessungen gemessen haben, markieren Sie die korrekten Positionen mit Bleistift und Lineal. | Schritt 2: Tragen Sie Konstruktionskleber auf die Rückseite der Zierleisten auf.  | Schritt 3: Befestigen Sie die Teile entsprechend ihrer Nummerierung an der Wand. Fixieren Sie sie mit Klebeband, bis der Klebstoff ausgehärtet ist. |

| JX60#-L3842  |   |  |
|--|---|--|
|              |   |  |
|  <p>Zoll</p> |  |  |

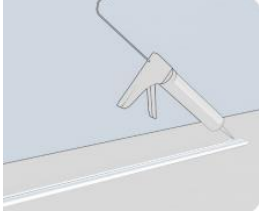
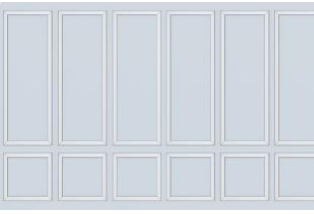
| 36 Stück   | 12 Stück  |  |
|--|---|--|
|    |        |    |
| <p>Schritt 1: Nachdem Sie die Abmessungen gemessen haben, markieren Sie die korrekten Positionen mit Bleistift und Lineal.</p> | <p>Schritt 2: Tragen Sie Konstruktionskleber auf die Rückseite der Zierleisten auf.</p> | <p>Schritt 3: Befestigen Sie die Teile entsprechend ihrer Nummerierung an der Wand. Fixieren Sie sie mit Klebeband, bis der Klebstoff ausgehärtet ist.</p> |

**JX88#-L1920**

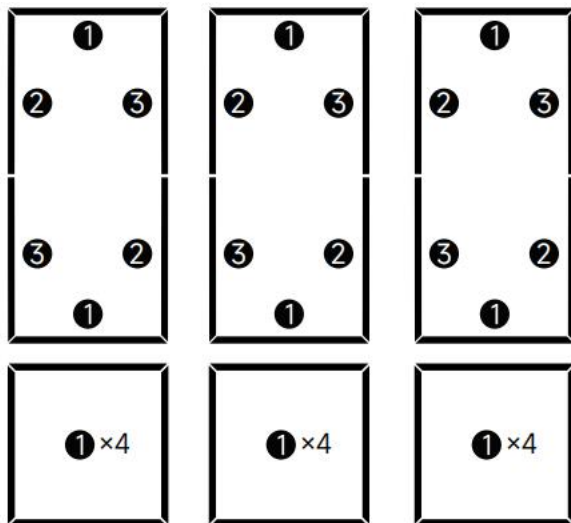

1 24

Zoll  
18 Stück



2 27 Zoll

6 Stück



3 27 Zoll

6 Stück

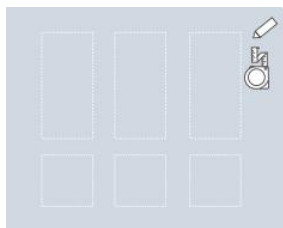

Schritt 1: Nachdem Sie die Abmessungen gemessen haben, markieren Sie die korrekten Positionen mit Bleistift und Lineal.

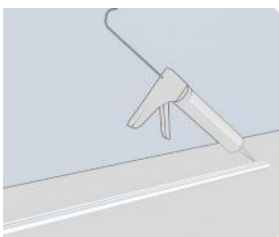

Schritt 2: Tragen Sie Konstruktionskleber auf die Rückseite der Zierleisten auf.

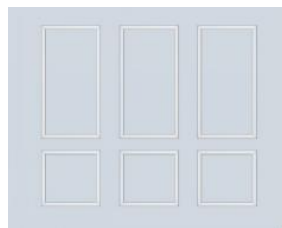

Schritt 3: Befestigen Sie die Teile entsprechend ihrer Nummerierung an der Wand. Fixieren Sie sie mit Klebeband, bis der Klebstoff ausgehärtet ist.

JC956#-JC960-L2044

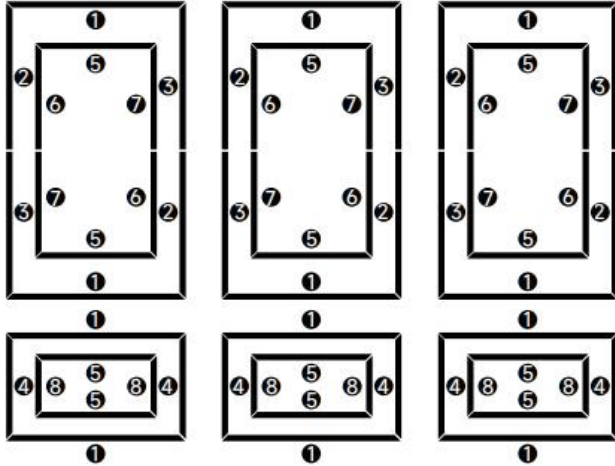

**1** 31 Zoll  
12 Stück



**2** 27 Zoll  
6 Stück



**3** 27 Zoll  
6 Stück



**4** 18 Zoll  
6 Stück



**5** 19 Zoll  
12 Stück



**6** 19 Zoll  
6 Stück



**7** 19 Zoll  
6 Stück



**8** 6 Zoll  
6 Stück

|  |  |   |
|--|--|---|
|   |          |    |
| <p>Schritt 1: Nachdem Sie die Abmessungen gemessen haben, markieren Sie die korrekten Positionen mit Bleistift und Lineal.</p> | <p>Schritt 2: Tragen Sie Konstruktionskleber auf die Rückseite der Zierleisten auf .</p> | <p>Schritt 3: Befestigen Sie sie entsprechend ihrer Nummerierung an der Wand. Fixieren Sie sie mit Klebeband, bis der Kleber ausgehärtet ist.</p> |

## SUMMARY

Die Montage von Wanddekorleisten basiert im Wesentlichen auf dem Prinzip „Vorausmessen, vorläufige Befestigung und spätere Ausbesserung“. Es ist wichtig, die Wandbeschaffenheit und die Werkzeuge an das Material der Dekorleisten anzupassen und dabei insbesondere auf Details wie die Verbindung von Innen- und Außenecken sowie die Wahl des Klebstoffs zu achten. So lässt sich ein gleichmäßiges, nahtloses, festes und dauerhaftes Dekorationsergebnis erzielen und Nacharbeiten oder ästhetische Beeinträchtigungen durch unsachgemäße Ausführung vermeiden.

**Hersteller:** Shanghaimuxinmuyeyouxiangongsi

**Adresse:** Shuangchenglu 803nong11hao1602A-1609shi, baoshanqu, Shanghai 200000 CN.

**Importiert nach Australien:** SIHAO PTY LTD. 1 ROKEVA STREET, EASTWOOD

NSW 2122 Australien

**Importiert in die USA:** Sanven Technology Ltd. Suite 250, 9166 Anaheim Ort, Rancho Cucamonga, CA 91730

|           |            |  |
|-----------|------------|--|
| <b>UK</b> | <b>REP</b> | YH CONSULTING LIMITED. C/O YH Consulting Limited Office 147, Centurion House, London Road, Staines-upon-Thames, Surrey, TW18 4AX |
|-----------|------------|--|

|           |            |  |
|-----------|------------|--|
| <b>EC</b> | <b>REP</b> | E-CrossStu GmbH<br>Mainzer Landstr.69,<br>60329 Frankfurt am Main. |
|-----------|------------|--|



# **VEVOR**

**Upgrade · The Home Creator Way**

## **MODANATURA PER PARETE**

**MODELLO: JX36#-L2438/JX88#-L2690/JX88#-L2165/  
JX36#-L1920/JX60#-L3842/JX88#-L1920/  
JC956#-JC960-L2044**



Modello: JX36#-L2438

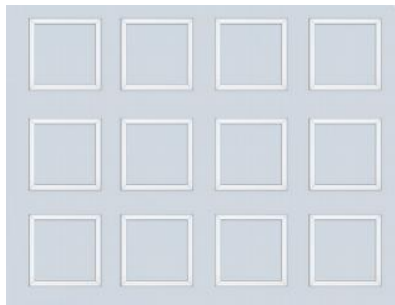

Modello: JX88#-L2690

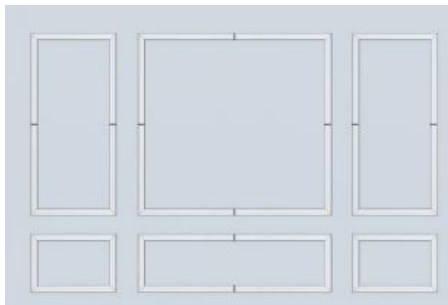

Modello: JX88#-L2165

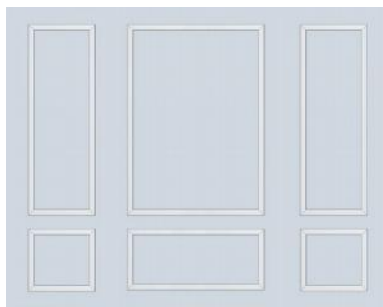

Modello: JC956#-JC960-L2044

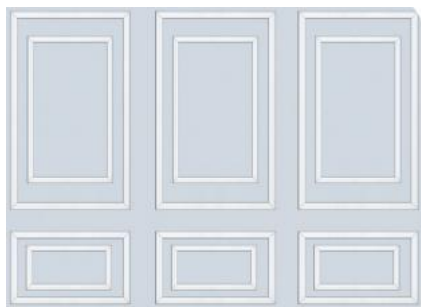

Modello: JX36#-L1920

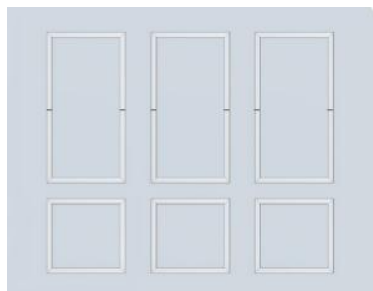

Modello: JX60#-L3842



Modello: JX88#-L1920

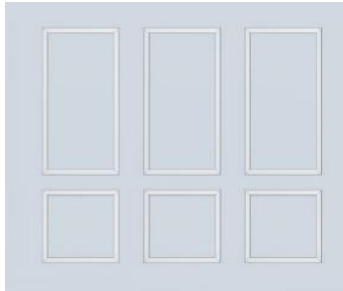

Queste sono le istruzioni originali, si prega di leggere attentamente tutte le istruzioni del manuale prima dell'uso. VEVOR si riserva la piena interpretazione del proprio manuale utente. L'aspetto del prodotto dipenderà dal prodotto ricevuto. Vi preghiamo di scusarci se non vi informeremo più in caso di aggiornamenti tecnologici o software sul nostro prodotto.



Avvertenza: per ridurre il rischio di lesioni, l'utente deve leggere attentamente il manuale di istruzioni.

## **DIMENSIONI MODANATURA PARETE**



Misura la tua parete prima di ordinare per garantire la corretta quantità ordinata

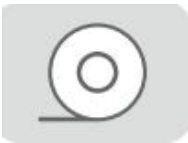

Grazie mille per aver scelto questa modanatura murale. Leggere attentamente le istruzioni prima di utilizzarla. Le informazioni vi aiuteranno a ottenere i migliori risultati possibili.

## TOOLS REQUIREMENT INTRODUCTION

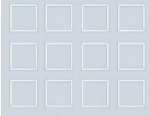
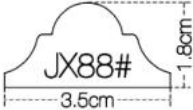
|   |   |   |
|---|---|---|
|  |  |  |
| Costruzione<br>Adesivo  | metro a nastro  | Matita  |
|  |  |  |
| Asciugamano   | Nastro di marcatura   | Guanti  |

## SAVE THIS MANUAL

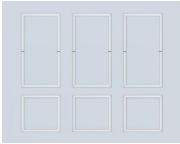
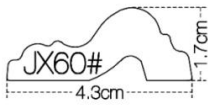
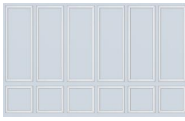
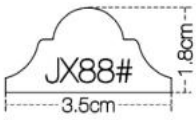
| Modello     | Motivo a strisce  | Effetto collage   |
|-------------|---|---|
| JX36#-L2438 |   |   |
| JX88#-L2690 |  |  |
| JX88#-L2165 |   |  |

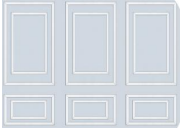
|                    |   |   |
|--------------------|---|---|
| JX36#-L1920        |  |   |
| JX60#-L3842        |  |  |
| JX88#-L1920        |  |  |
| JC956#-JC960-L2044 |  |  |

## BEFORE INSTALLATION: FOUNDATION PREPARATION

### Ispezione delle condizioni della parete: assicurarsi che la "base sia qualificata"

L'installazione delle strisce decorative si basa su pareti piane, asciutte e robuste e deve essere verificata una per una nella fase iniziale:

**Planarità:** utilizzare un righello da 2 metri per testare la superficie della parete, con un errore  $\leq 3$  mm. Se sono presenti sporgenze, depressioni o crepe sulla superficie della parete, applicare prima dello stucco per livellarla (si consiglia di utilizzare stucco resistente all'acqua, soprattutto in aree umide come bagni e cucine). Dopo l'asciugatura, utilizzare carta vetrata per lucidare fino a ottenere una superficie liscia.

**Grado di asciugatura:** la nuova superficie della parete deve essere completamente asciutta (si consiglia di ventilare per almeno 7 giorni dopo aver dipinto le pareti con vernice al lattice e di mantenerla per 28 giorni per

le pareti in cemento), per evitare che l'umidità si riformi sulla superficie della parete in una fase successiva, il che potrebbe causare la caduta o la formazione di muffa delle strisce decorative.

Pulizia: rimuovere polvere, macchie d'olio e cenere galleggiante dalla superficie della parete. Utilizzare un panno umido per pulire e asciugare all'aria per evitare che l'adesivo perda aderenza.

## INSTALLATION STEPS

### JX36#-L2438

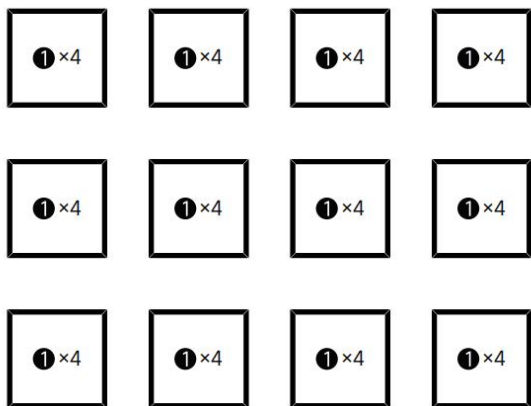

**1** 20"  
48 pezzi

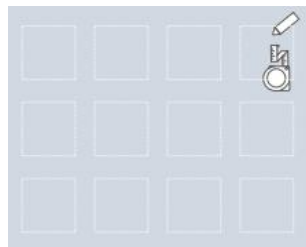

P assaggio 1: Dopo aver misurato le dimensioni, utilizzare una matita e un righello

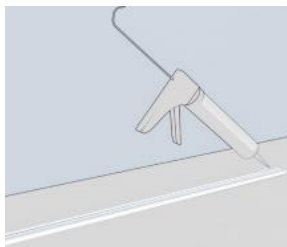



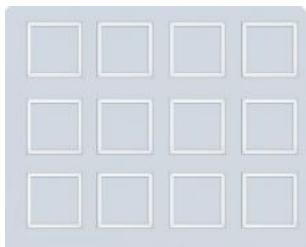



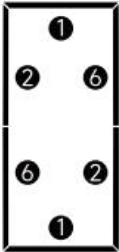
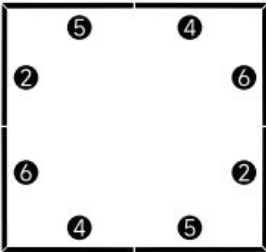
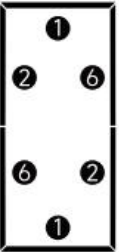
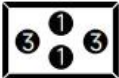

Fase 2: Applicare l'adesivo da costruzione sul retro delle modanature .

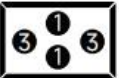





Fase 3: Fissateli al muro in base al numero. Usate del nastro adesivo per

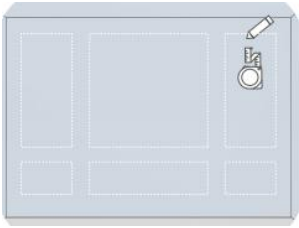
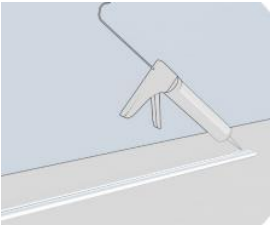
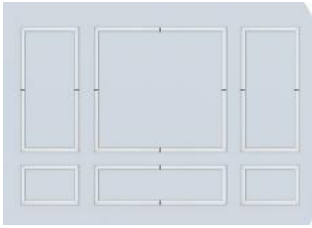

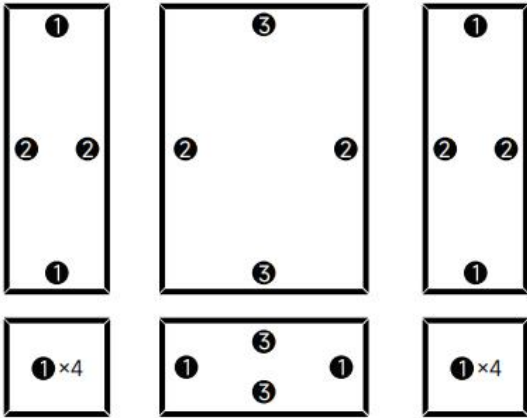

|                                    |  |  |
|------------------------------------|--|--|
| per segnare le posizioni corrette. |  | tenerli fermi finché l'adesivo non si asciuga. |
|------------------------------------|--|--|

| JX88#-L2690  |  |  |
|--|--|--|
|   |   |   |
|   |   |   |
|  <p data-bbox="199 962 288 1007">① 31 "</p> <p data-bbox="199 1034 288 1066">8 pezzi</p>    |  <p data-bbox="505 962 628 1007">② 31,5 "</p> <p data-bbox="505 1034 605 1066">6 pezzi</p>  |  <p data-bbox="829 943 930 991">③ 24 "</p> <p data-bbox="829 1018 930 1050">6 pezzi</p>       |
|  <p data-bbox="199 1142 288 1190">④ 36 "</p> <p data-bbox="199 1217 288 1249">4 pezzi</p> |  <p data-bbox="516 1142 605 1190">⑤ 36 "</p> <p data-bbox="516 1217 605 1249">4 pezzi</p> |  <p data-bbox="818 1142 941 1190">⑥ 31,5 "</p> <p data-bbox="829 1217 930 1249">6 pezzi</p> |

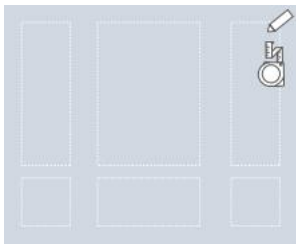
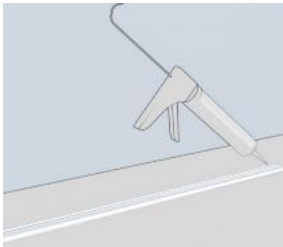
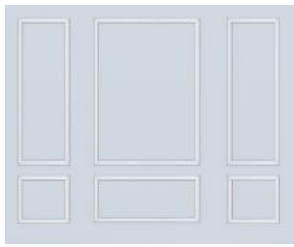

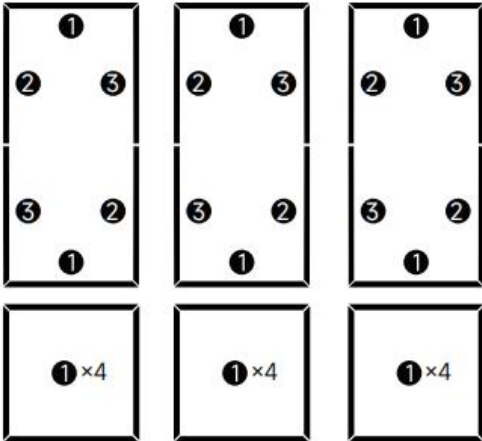
|   |  |   |
|---|--|---|
|    |  |    |
| <p>P assaggio 1: Dopo aver misurato le dimensioni, utilizzare una matita e un righello per segnare le posizioni corrette.</p> | <p>Fase 2: Applicare l'adesivo da costruzione sul retro delle modanature .</p>   | <p>Fase 3: Fissateli al muro in base al numero. Usate del nastro adesivo per tenerli fermi finché l'adesivo non si asciuga.</p> |

| <b>JX88#-L2165</b>  |  |  |
|---|--|--|
|                                     |  |  |
|  <p><b>1</b> 23 ”<br/>14 pezzi</p> |  <p><b>2</b> 56,3 ”<br/>6 pezzi</p> |  <p><b>3</b> 48 ”<br/>4 pezzi</p> |

|  |  |   |
|--|--|---|
|   |  |    |
| <p>Fase 1: Dopo aver misurato le dimensioni, utilizzare una matita e un righello per contrassegnare le posizioni corrette.</p> | <p>Fase 2: applicare l'adesivo da costruzione sul retro delle modanature.</p>    | <p>Fase 3: Fissateli al muro in base al numero. Usate del nastro adesivo per tenerli fermi finché l'adesivo non si asciuga.</p> |

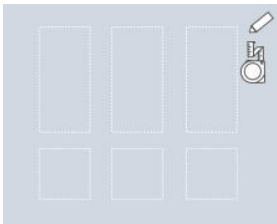
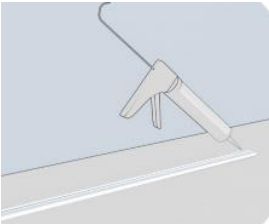
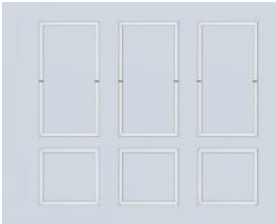

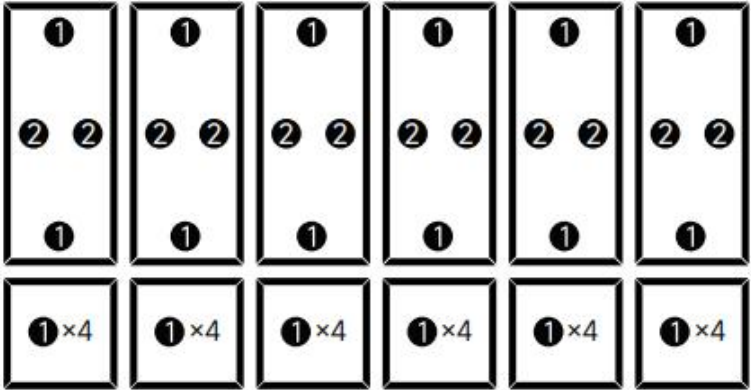
| <b>JX36#-L1920</b>   |  |  |
|--|--|--|
|                                    |  |  |
|  <p><b>1</b> 24<br/>" 18 pezzi</p> |  <p><b>2</b> 27 "<br/>6 pezzi</p> |  <p><b>3</b> 27 "<br/>6 pezzi</p> |

|  |  |   |
|--|--|---|
|    |  |    |
| <p>Fase 1: Dopo aver misurato le dimensioni, utilizzare una matita e un righello per contrassegnare le posizioni corrette.</p> | <p>Fase 2: applicare l'adesivo da costruzione sul retro delle modanature.</p>    | <p>Fase 3: Fissateli al muro in base al numero. Usate del nastro adesivo per tenerli fermi finché l'adesivo non si asciuga.</p> |

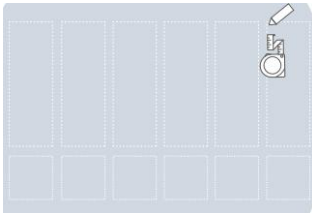
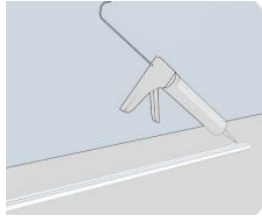
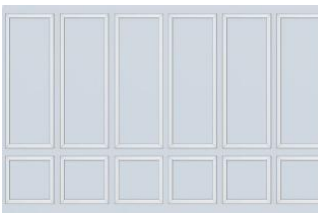
|   |   |  |
|---|---|--|
| <b>JX60#-L3842</b>  |   |  |
|   |   |  |
|  <p style="text-align: center;">"</p> <p style="text-align: center;">36 pezzi</p> |  <p style="text-align: center;">54 "</p> <p style="text-align: center;">12 pezzi</p> |  |

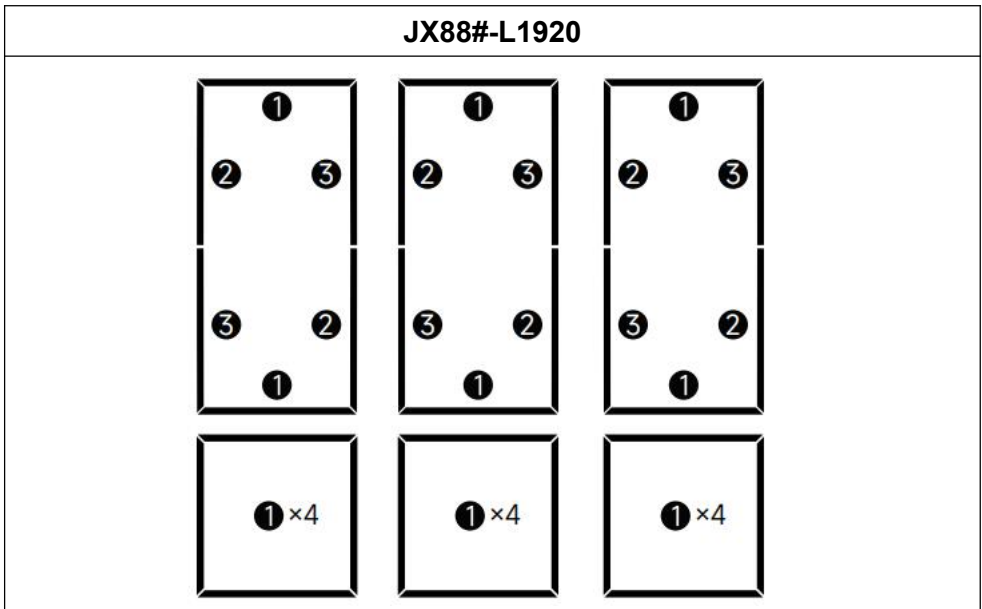



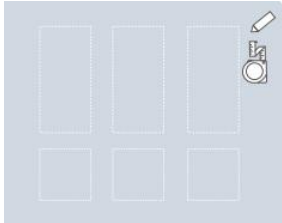
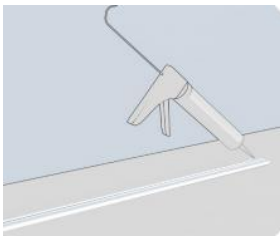
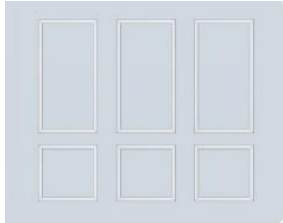

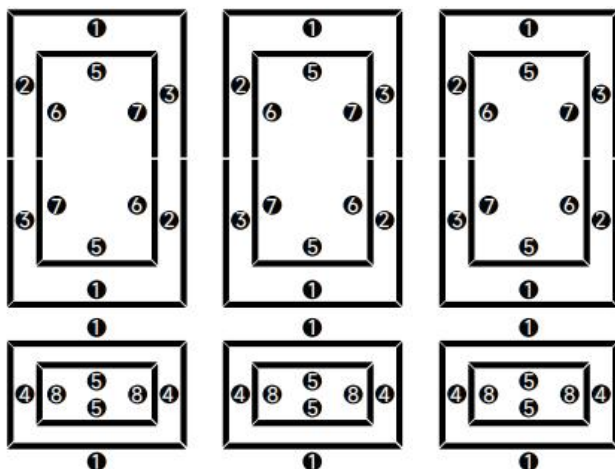

|  |  |   |
|--|--|---|
|   |  |    |
| <p>Fase 1: Dopo aver misurato le dimensioni, utilizzare una matita e un righello per contrassegnare le posizioni corrette.</p> | <p>Fase 2: applicare l'adesivo da costruzione sul retro delle modanature.</p>    | <p>Fase 3: Fissateli al muro in base al numero. Usate del nastro adesivo per tenerli fermi finché l'adesivo non si asciuga.</p> |



|  |  |   |
|--|--|---|
|  <p>"</p> <p>18 pezzi</p>                      |  <p>27"</p> <p>6 pezzi</p> |  <p>27"</p> <p>6 pezzi</p> |
|    |   |   |
| <p>Fase 1: Dopo aver misurato le dimensioni, utilizzare una matita e un righello per contrassegnare le posizioni corrette.</p> | <p>Fase 2: applicare l'adesivo da costruzione sul retro delle modanature.</p>  | <p>Fase 3: Fissateli al muro in base al numero. Usate del nastro adesivo per tenerli fermi finché l'adesivo non si asciuga.</p>       |

### JC956#-JC960-L2044

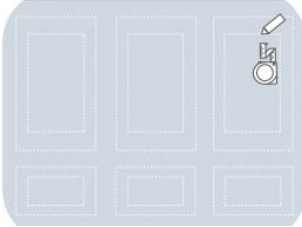
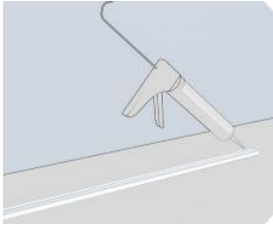
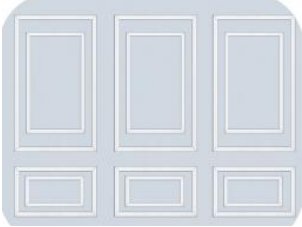

|   |  |   |
|---|--|---|
|  <p><b>1</b> 31 "</p> <p>12 pezzi</p>         |  <p><b>2</b> 27 "</p> <p>6 pezzi</p>   |  <p><b>3</b> 27 "</p> <p>6 pezzi</p>            |
|  <p><b>4</b> 18 "</p> <p>6 pezzi</p>         |  <p><b>5</b> 19 "</p> <p>12 pezzi</p> |  <p><b>6</b> 19 "</p> <p>6 pezzi</p>           |
|  <p><b>7</b> 19 "</p> <p>6 pezzi</p>         |  <p><b>8</b> 6 "</p> <p>6 pezzi</p>   |   |
|   |                                       |   |
| <p>P assaggio 1: Dopo aver misurato le dimensioni, utilizzare una matita e un righello per segnare le posizioni corrette.</p> | <p>Fase 2: Applicare l'adesivo da costruzione sul retro delle modanature .</p>   | <p>Fase 3: Fissateli al muro in base al numero. Usate del nastro adesivo per tenerli fermi finché l'adesivo non si asciuga.</p> |

## SUMMARY

Il fulcro dell'installazione di strisce decorative murali è la "misurazione preliminare, il fissaggio a metà strada e la successiva riparazione". È

necessario adattare le condizioni della parete e gli strumenti in base al materiale delle strisce decorative, prestando particolare attenzione a dettagli come la giunzione degli angoli interni ed esterni e la scelta dell'adesivo, al fine di ottenere un effetto decorativo "liscio, senza soluzione di continuità, solido e durevole" ed evitare rilavorazioni o deterioramenti estetici dovuti a un utilizzo improprio.

**Produttore:** Shanghai muxinmuyeyouxiangongsi

**Indirizzo:** Shuangchenglu 803nong11hao1602A-1609shi, baoshanqu, Shanghai 200000 CN.

**Importato in AUS:** SIHAO PTY LTD. 1 ROKEVA STREET EASTWOOD  
Nuovo Galles del Sud 2122 Australia

**Importato negli USA:** Sanven Technology Ltd. Suite 250, 9166 Anaheim  
Luogo, Rancho Cucamonga, CA 91730

|           |            |  |
|-----------|------------|--|
| <b>UK</b> | <b>REP</b> | YH CONSULTING LIMITED. C/O YH Consulting<br>Limited Office 147, Centurion House, London<br>Road, Staines-upon-Thames, Surrey, TW18 4AX |
|-----------|------------|--|

|           |            |  |
|-----------|------------|--|
| <b>EC</b> | <b>REP</b> | E-CrossStu GmbH<br>Mainzer Landstr.69,<br>60329 Frankfurt am Main. |
|-----------|------------|--|



# **VEVOR**

**Upgrade · The Home Creator Way**

## **MOLDURA DE PARED**

**MODELO: JX36#-L2438/JX88#-L2690/JX88#-L2165/  
JX36#-L1920/JX60#-L3842/JX88#-L1920/  
JC956#-JC960-L2044**



Modelo: JX36#-L2438

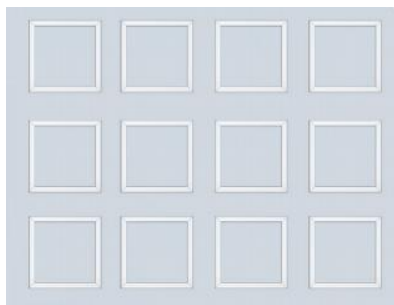

Modelo: JX88#-L2690

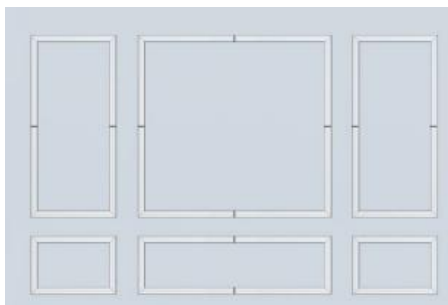

Modelo: JX88#-L2165

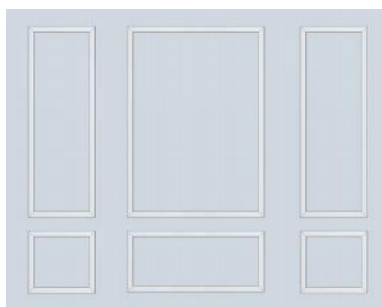

Modelo: JC956#-JC960-L2044

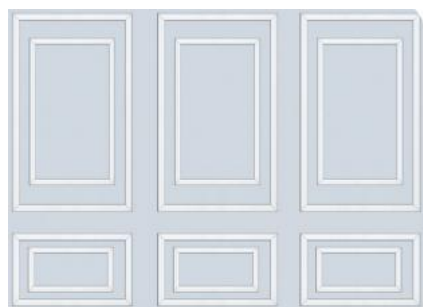

Modelo: JX36#-L1920

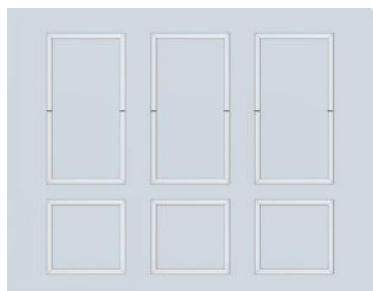

Modelo: JX60#-L3842

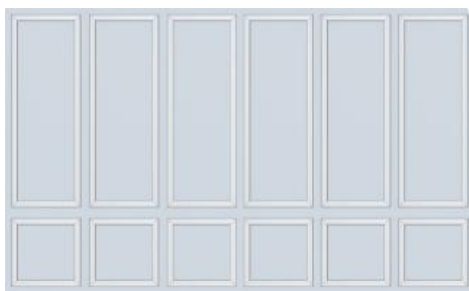

Modelo: JX88#-L1920

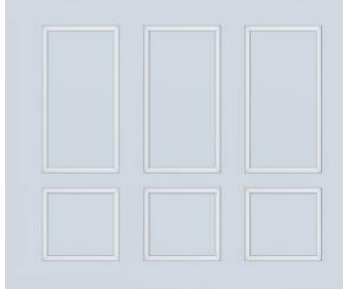

Estas son las instrucciones originales; lea atentamente todas las instrucciones del manual antes de utilizarlo. VEVOR se reserva el derecho de interpretar este manual de usuario. La apariencia del producto dependerá del producto que haya recibido. Le rogamos que nos disculpe si no le informamos de nuevo si hay actualizaciones tecnológicas o de software en nuestro producto.





Advertencia: Para reducir el riesgo de lesiones, el usuario debe leer atentamente el manual de instrucciones.

## **DIMENSIONES DE MOLDURA DE PARED**



Mide tu pared antes de realizar el pedido Para garantizar la cantidad correcta solicitada

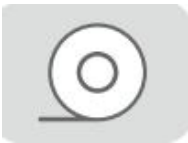

Muchas gracias por elegir esta moldura de pared. Lea todas las instrucciones antes de usarla. Esta información le ayudará a obtener los mejores resultados.

## TOOLS REQUIREMENT INTRODUCTION

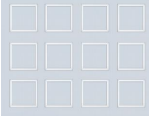
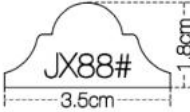
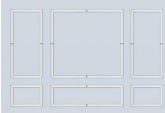
|   |   |   |
|---|---|---|
|  |  |  |
| Construcción<br>Adhesivo  | Cinta métrica   | Lápiz   |
|  |  |  |
| Toalla  | Cinta de marcado  | Guantes   |

## SAVE THIS MANUAL

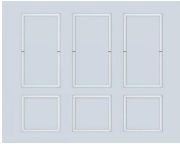
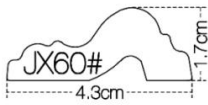
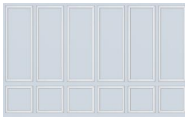
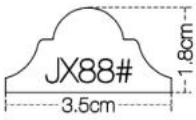
| Modelo      | Patrón de tiras   | Efecto collage  |
|-------------|---|---|
| JX36#-L2438 |   |   |
| JX88#-L2690 |  |  |
| JX88#-L2165 |   |  |

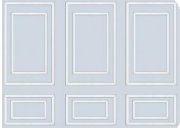
|                    |   |   |
|--------------------|---|---|
| JX36#-L1920        |  |   |
| JX60#-L3842        |  |  |
| JX88#-L1920        |  |  |
| JC956#-JC960-L2044 |  |  |

## BEFORE INSTALLATION: FOUNDATION PREPARATION

### **Inspección del estado de la pared: Asegúrese de que la "base esté calificada"**

La instalación de tiras decorativas depende de paredes planas, secas y resistentes, y es necesario verificarlas una por una en la etapa inicial:

**Planitud:** Use una regla de 2 metros para comprobar la superficie de la pared, con un error de  $\leq 3$  mm. Si hay protuberancias, depresiones o grietas en la pared, aplique primero masilla para nivelarla (se recomienda usar masilla resistente al agua, especialmente en zonas húmedas como baños y cocinas). Después del secado, use papel de lija para pulirla hasta que quede lisa.

**Grado de secado:** La nueva superficie de la pared debe estar completamente seca (se recomienda ventilar durante al menos 7 días después de pintar paredes con pintura de látex, y mantener durante 28

días para paredes de cemento), para evitar la recuperación de humedad en la superficie de la pared en la etapa posterior, lo que puede provocar que las tiras decorativas se caigan o se enmohezcan.

Limpieza: Elimine el polvo, las manchas de aceite y la ceniza flotante de la superficie de la pared. Use un paño húmedo para limpiar y deje secar al aire para evitar que el adhesivo pierda adherencia.

## INSTALLATION STEPS

### JX36#-L2438

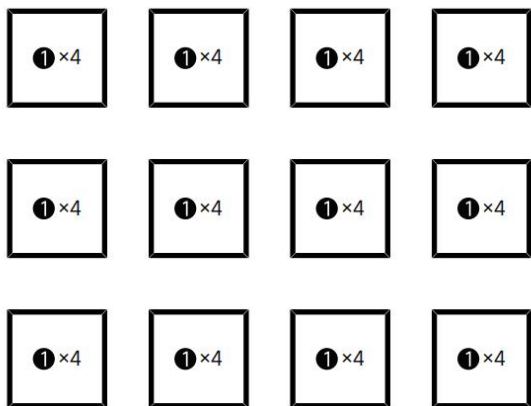

**1** 20"  
48 piezas

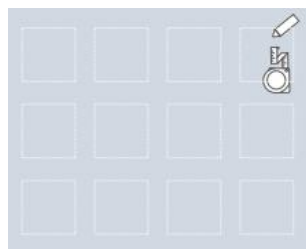

Paso 1: Después de medir las dimensiones, utilice un lápiz y una regla para marcar las

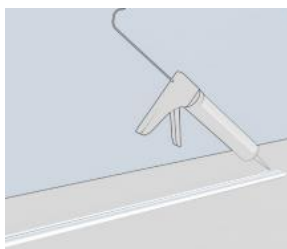



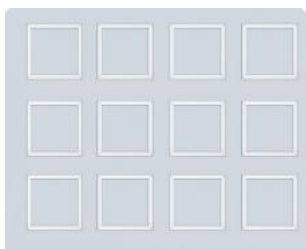





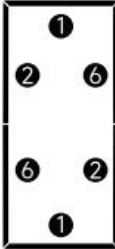
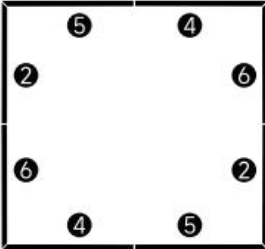
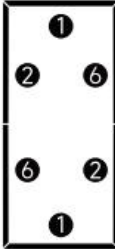
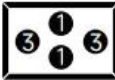

Paso 2: Aplique adhesivo de construcción en la parte posterior de





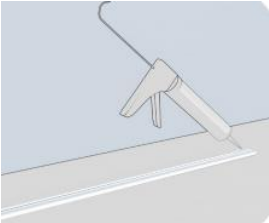
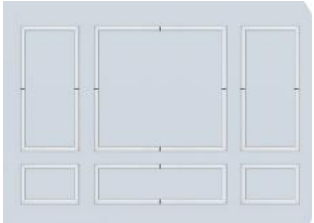

Paso 3: Pégalos a la pared según su número. Usa cinta adhesiva para fijarlos

|                       |                |                                 |
|-----------------------|----------------|---------------------------------|
| posiciones correctas. | las molduras . | hasta que el adhesivo se seque. |
|-----------------------|----------------|---------------------------------|



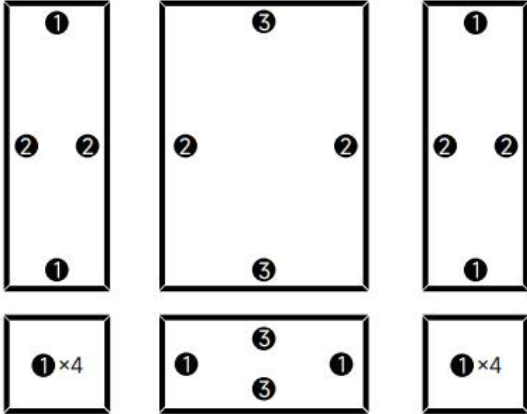

**JX88#-L2690**

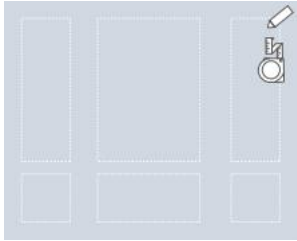
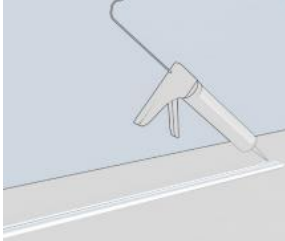
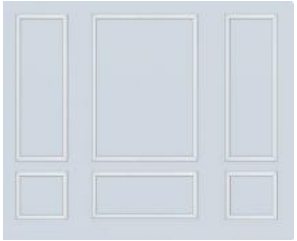
|  |  |  |
|--|--|--|
|                                 |                                 |                                   |
|                                 |                                 |                                   |
| <br><b>1</b> 31 "<br>8 piezas   | <br><b>2</b> 31,5 "<br>6 piezas | <br><b>3</b> 24 "<br>6 piezas     |
| <br><b>4</b> 36 "<br>4 piezas | <br><b>5</b> 36 "<br>4 piezas | <br><b>6</b> 31,5 "<br>6 piezas |
|                                |                               |                                |

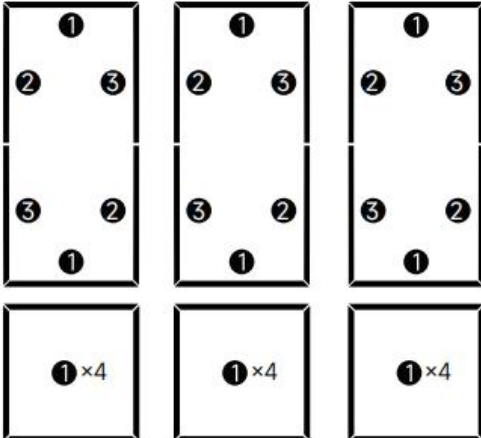

|   |   |   |
|---|---|---|
| <p>Paso 1: Después de medir las dimensiones, utilice un lápiz y una regla para marcar las posiciones correctas.</p> | <p>Paso 2: Aplique adhesivo de construcción en la parte posterior de las molduras .</p> | <p>Paso 3: Pégalos a la pared según su número. Usa cinta adhesiva para fijarlos hasta que el adhesivo se seque.</p> |
|---|---|---|

| <b>JX88#-L2165</b>  |  |  |
|---|--|--|
|                                        |  |  |
|  <p><b>1</b> 23 "</p> <p>14 piezas</p> |  <p><b>2</b> 56.3 "</p> <p>6 piezas</p> |  <p><b>3</b> 48 "</p> <p>4 piezas</p> |
|                                       |                                       |                                    |
| <p>Paso 1: Después de medir las dimensiones,</p>  | <p>Paso 2: Aplique adhesivo de</p>   | <p>Paso 3: Fíjalos a la pared según su</p>   |

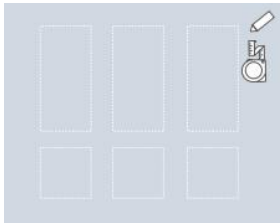
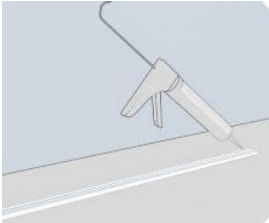
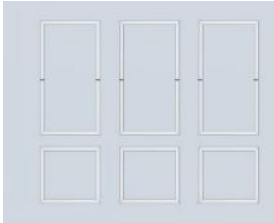
|   |  |   |
|---|--|---|
| <p>use un lápiz y una regla para marcar las posiciones correctas.</p> | <p>construcción en la parte posterior de las molduras.</p> | <p>número. Usa cinta adhesiva para fijarlos hasta que el adhesivo se seque.</p> |
|---|--|---|

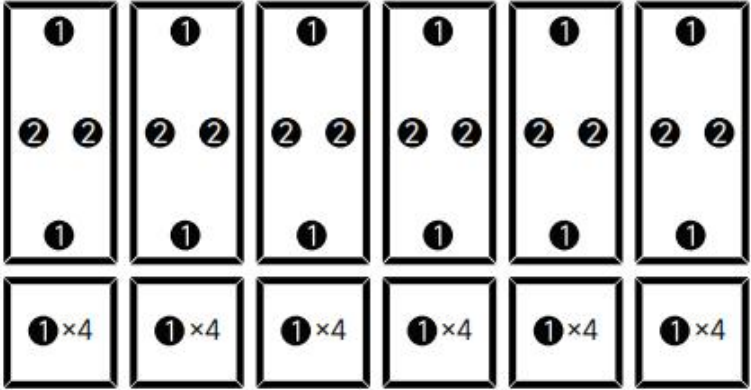

| <p align="center"><b>JX36#-L1920</b></p>  |  |  |
|---|--|--|
|    |  |  |
|  <p align="center"><b>1</b> 24 "</p> <p align="center">18 piezas</p> |  <p align="center"><b>2</b> 27 "</p> <p align="center">6 piezas</p> |  <p align="center"><b>3</b> 27 "</p> <p align="center">6 piezas</p> |
|    |   |    |
| <p>Paso 1: Después de medir las dimensiones,</p>  | <p>Paso 2: Aplique adhesivo de</p>   | <p>Paso 3: Fíjalos a la pared según su</p>   |

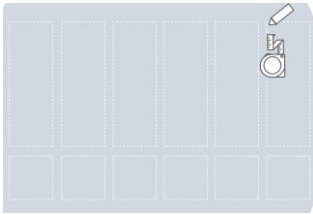
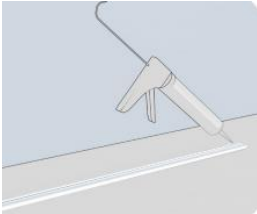
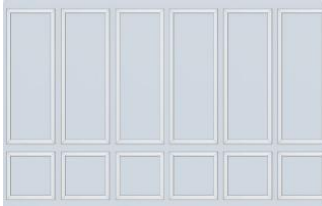

|   |  |   |
|---|--|---|
| <p>use un lápiz y una regla para marcar las posiciones correctas.</p> | <p>construcción en la parte posterior de las molduras.</p> | <p>número. Usa cinta adhesiva para fijarlos hasta que el adhesivo se seque.</p> |
|---|--|---|

| <p align="center"><b>JX60#-L3842</b></p>  |   |  |
|---|---|--|
|    |   |  |
|  <p align="center"><b>1</b> 24 "</p> <p align="center">36 piezas</p> |  <p align="center"><b>2</b> 54 "</p> <p align="center">12 piezas</p> |  |
|   |    |  |
| <p>Paso 1: Después de medir las dimensiones, use un lápiz y una regla</p>   | <p>Paso 2: Aplique adhesivo de construcción en la</p>   | <p>Paso 3: Fíjalos a la pared según su número. Usa cinta</p>                         |





|                                       |                                  |  |
|---------------------------------------|----------------------------------|--|
| para marcar las posiciones correctas. | parte posterior de las molduras. | adhesiva para fijarlos hasta que el adhesivo se seque. |
|---------------------------------------|----------------------------------|--|



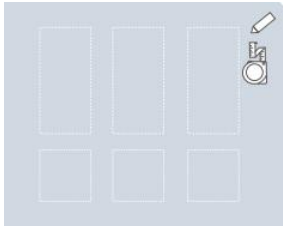
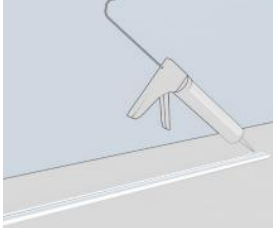
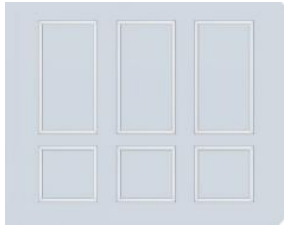

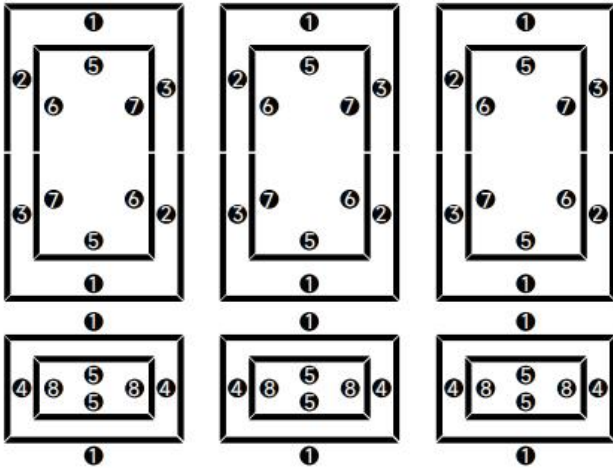
**JX88#-L1920**

|  |   |   |
|--|---|---|
|  24"<br>18 piezas |  27"<br>6 piezas |  27"<br>6 piezas |
|--|---|---|

|   |  |   |
|---|--|---|
|                                  |        |                                    |
| <p>Paso 1: Después de medir las dimensiones, use un lápiz y una regla para marcar las posiciones correctas.</p> | <p>Paso 2: Aplique adhesivo de construcción en la parte posterior de las molduras.</p> | <p>Paso 3: Fíjalos a la pared según su número. Usa cinta adhesiva para fijarlos hasta que el adhesivo se seque.</p> |

|   |  |  |
|---|--|--|
| <b>JC956#-JC960-L2044</b>   |  |  |
|   |  |  |
|  <p style="text-align: center;"><b>1</b> 31 "</p> <p style="text-align: center;">12 piezas</p> |  <p style="text-align: center;"><b>2</b> 27 "</p> <p style="text-align: center;">6 piezas</p> |  <p style="text-align: center;"><b>3</b> 27 "</p> <p style="text-align: center;">6 piezas</p> |

|   |  |   |
|---|--|---|
|  <p><b>4</b> 18 ”<br/>6 piezas</p> |  <p><b>5</b> 19 ”<br/>12 piezas</p> |  <p><b>6</b> 19 ”<br/>6 piezas</p> |
|  <p><b>7</b> 19 ”<br/>6 piezas</p> |  <p><b>8</b> 6 ”<br/>6 piezas</p>   |   |
|                                     |                                     |                                   |
| <p>Paso 1: Después de medir las dimensiones, utilice un lápiz y una regla para marcar las posiciones correctas.</p> | <p>Paso 2: Aplique adhesivo de construcción en la parte posterior de las molduras .</p>                              | <p>Paso 3: Pégalos a la pared según su número. Usa cinta adhesiva para fijarlos hasta que el adhesivo se seque.</p> |

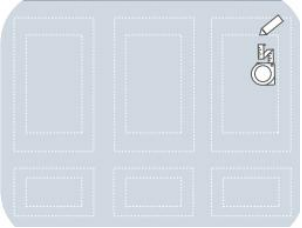
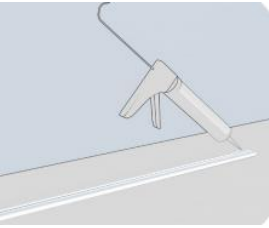
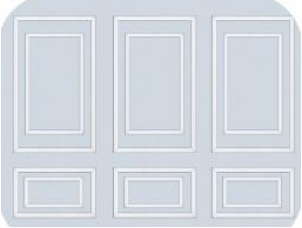
## SUMMARY

La base de la instalación de tiras decorativas de pared es la medición previa, la fijación intermedia y la posterior reparación. Es necesario adaptar las condiciones de la pared y las herramientas al material de las tiras decorativas, prestando especial atención a detalles como la unión de las esquinas internas y externas y la selección del adhesivo, para lograr un efecto decorativo uniforme, firme y duradero, y evitar repasos o deterioro estético por un uso inadecuado.

**Fabricante:** Shanghaimuxinmuyeyouxiangongsi

**Dirección:** Shuangchenglu 803nong11hao1602A-1609shi, baoshanqu, Shanghái 200000 CN.

**Importado a AUS:** SIHAO PTY LTD. 1 ROKEVA STREET EASTWOOD NSW 2122 Australia

**Importado a EE. UU.:** Sanven Technology Ltd. Suite 250, 9166 Anaheim Lugar, Rancho Cucamonga, CA 91730

|           |            |  |
|-----------|------------|--|
| <b>UK</b> | <b>REP</b> | YH CONSULTING LIMITED. C/O YH Consulting Limited Office 147, Centurion House, London Road, Staines-upon-Thames, Surrey, TW18 4AX |
|-----------|------------|--|

|           |            |  |
|-----------|------------|--|
| <b>EC</b> | <b>REP</b> | E-CrossStu GmbH<br>Mainzer Landstr.69,<br>60329 Frankfurt am Main. |
|-----------|------------|--|



# **VEVOR**

**Upgrade · The Home Creator Way**

## **LISTWA ŚCIENNA**

**MODELE: JX36#-L2438/JX88#-L2690/JX88#-L2165/  
JX36#-L1920/JX60#-L3842/JX88#-L1920/  
JC956#-JC960-L2044**



Model: JX36#-L2438

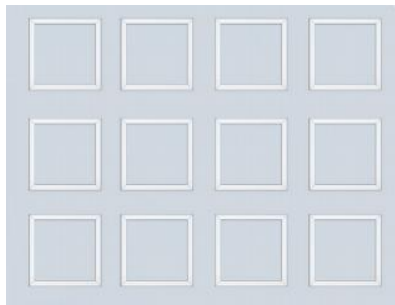

Model: JX88#-L2690

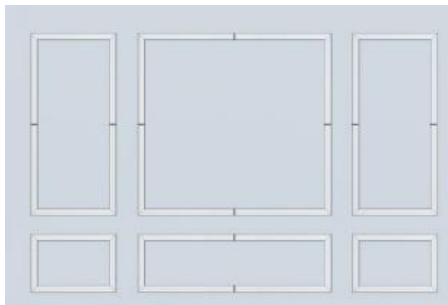

Model: JX88#-L2165

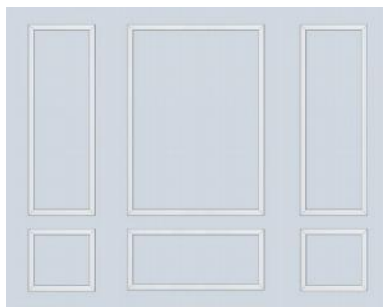

Model: JC956#-JC960-L2044

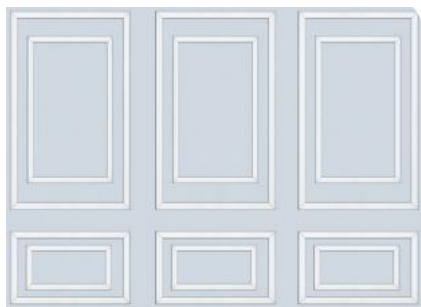

Model: JX36#-L1920

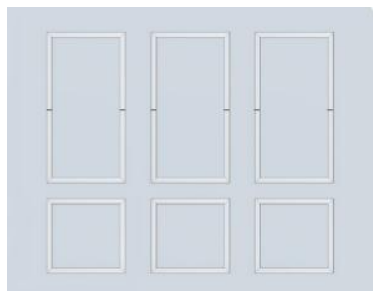

Model: JX60#-L3842

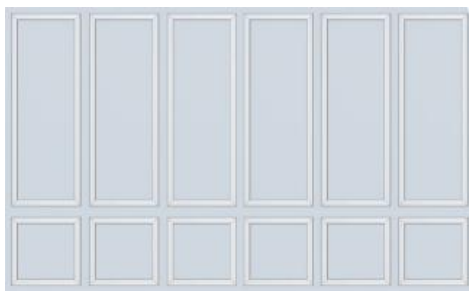

Model: JX88#-L1920

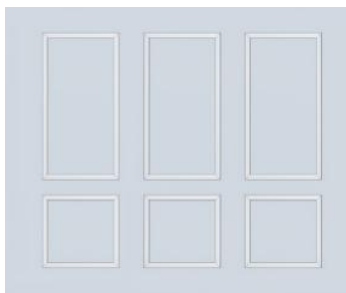

To jest oryginalna instrukcja obsługi. Przed użyciem prosimy o dokładne zapoznanie się z treścią instrukcji. Firma VEVOR zastrzega sobie prawo do jednoznacznej interpretacji niniejszej instrukcji obsługi. Wygląd produktu zależy od stanu, w jakim go otrzymali Państwo. Prosimy o wyrozumiałość, ale nie będziemy Państwa ponownie informować o aktualizacjach technologicznych lub oprogramowania naszego produktu.



Ostrzeżenie: Aby zminimalizować ryzyko obrażeń, użytkownik powinien uważnie przeczytać instrukcję obsługi.

## WYMIARY LISTWY ŚCIENNEJ



Zmierz ścianę przed złożeniem zamówienia aby upewnić się, że zamówiona ilość jest prawidłowa



Dziękujemy bardzo za wybór tej listwy ściiennej. Przed użyciem prosimy o przeczytanie całej instrukcji. Zawarte w niej informacje pomogą Państwu osiągnąć jak najlepsze rezultaty.

## TOOLS REQUIREMENT INTRODUCTION

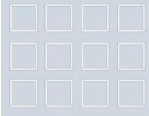
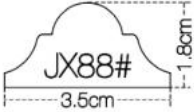
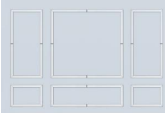
|   |   |   |
|---|---|---|
|  |  |  |
| B u r u k c j a<br>S p o i w o  | Taśma miernicza   | Ołówek  |
|  |  |  |
| Ręcznik   | Taśma znakująca   | Rękawice  |

## SAVE THIS MANUAL

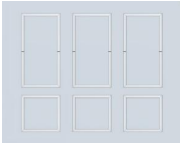
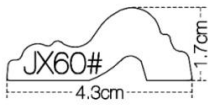
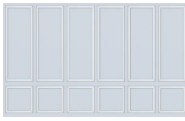
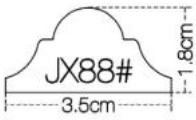
| Model       | Wzór pasków   | Efekt kolażu  |
|-------------|---|---|
| JX36#-L2438 |   |   |
| JX88#-L2690 |  |  |
| JX88#-L2165 |   |  |

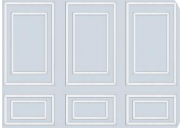
|                    |   |   |
|--------------------|---|---|
| JX36#-L1920        |  |   |
| JX60#-L3842        |  |  |
| JX88#-L1920        |  |  |
| JC956#-JC960-L2044 |  |  |

## BEFORE INSTALLATION: FOUNDATION PREPARATION

### Kontrola stanu ścian: Upewnij się, że „podłoże jest kwalifikowane”

Montaż pasów dekoracyjnych odbywa się na płaskich, suchych i solidnych ścianach, dlatego też należy go sprawdzać indywidualnie na wczesnym etapie:

**Płaskość:** Użyj 2-metrowej linijki, aby sprawdzić powierzchnię ściany, z tolerancją  $\leq 3$  mm. Jeśli na powierzchni ściany występują wypukłości, zagłębienia lub pęknięcia, najpierw wyrównaj ją szpachlówką (zaleca się stosowanie szpachli wodoodpornej, szczególnie w wilgotnych pomieszczeniach, takich jak łazienki i kuchnie). Po wyschnięciu wypoleruj powierzchnię papierem ściernym.

**Stopień wysuszenia:** Nowa powierzchnia ściany powinna być całkowicie sucha (zaleca się wietrzenie ścian przez co najmniej 7 dni po pomalowaniu ich farbą lateksową, a przez 28 dni w przypadku ścian cementowych), aby

zapobiec ponownemu zawilgoceniu powierzchni ściany w późniejszym etapie, co może spowodować odpadanie pasków dekoracyjnych lub powstawanie pleśni.

Czystość: Usuń kurz, plamy oleju i unoszący się popiół z powierzchni ściany. Przetrzyj wilgotną ściereczką i pozostaw do wyschnięcia na powietrzu, aby zapobiec utracie przyczepności kleju.

## INSTALLATION STEPS

### JX36#-L2438

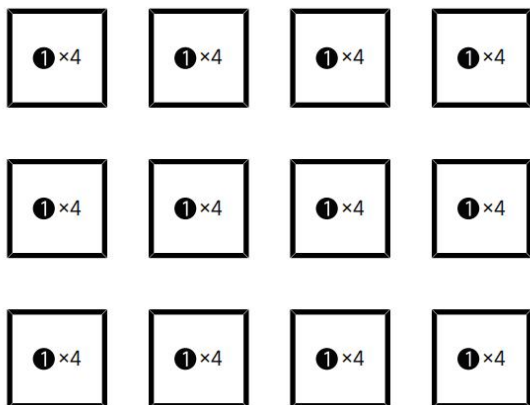

**1** 20 cali  
48 sztuk

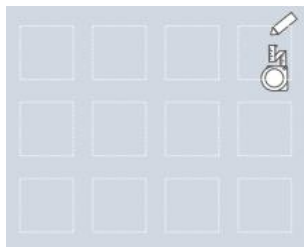

Krok 1: Po zmierzeniu wymiarów zaznacz odpowiednie pozycje ołówkiem i linijką.

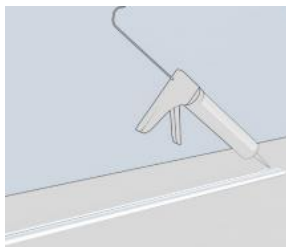

Krok 2: Nałóż klej budowlany na tylną część listew wykończeniowych .

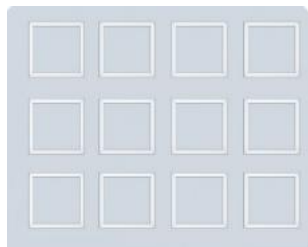

Krok 3: Przymocuj je do ściany zgodnie z ich numeracją. Użyj taśmy klejącej, aby je

przytrzymać, aż klej wyschnie.

### JX88#-L2690

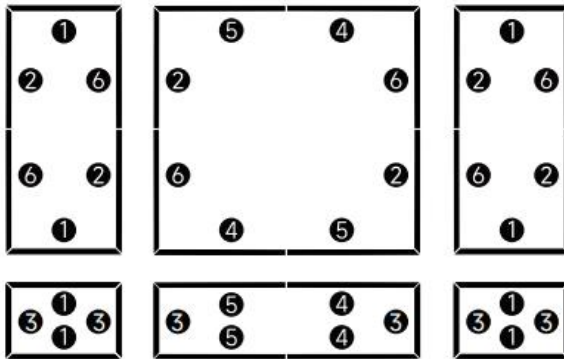

**1** 31 cali  
8 sztuk



**2** 31,5 cala  
6 sztuk



**3** 24 cale  
6 sztuk



**4** 36 cali  
4 sztuki







**5** 36 cali  
4 sztuki

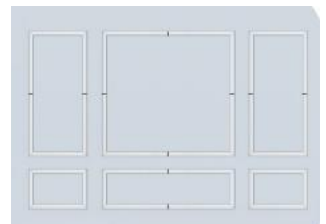
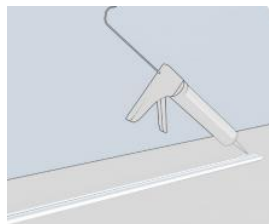
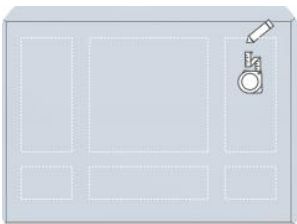



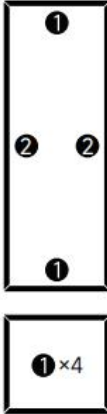
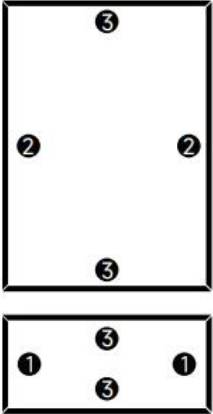
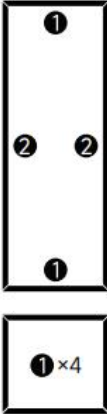

**6** 31,5 cala  
6 sztuk

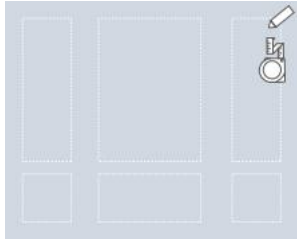
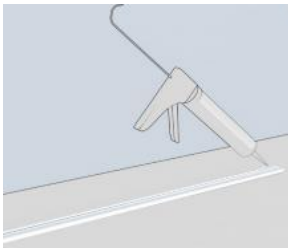
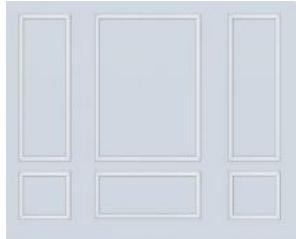

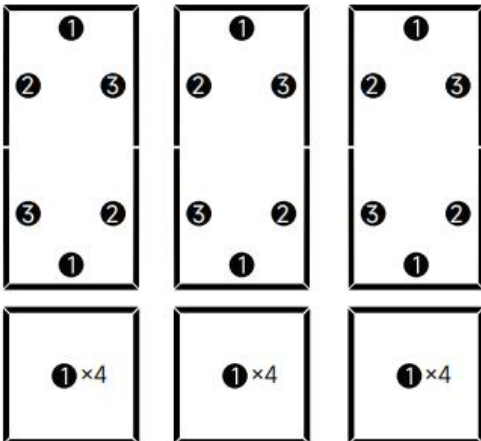

|   |   |   |
|---|---|---|
| <p>Krok 1: Po zmierzeniu wymiarów zaznacz odpowiednie pozycje ołówkiem i linijką.</p> | <p>Krok 2: Nałóż klej budowlany na tylną część listew wykończeniowych .</p> | <p>Krok 3: Przymocuj je do ściany zgodnie z ich numeracją. Użyj taśmy klejącej, aby je przytrzymać, aż klej wyschnie.</p> |
|---|---|---|

| <b>JX88#-L2165</b>   |   |  |
|--|---|--|
|                                       |                                        |                                       |
|  <p><b>1</b> 23 cale<br/>14 sztuk</p> |  <p><b>2</b> 56,3 cala<br/>6 sztuk</p> |  <p><b>3</b> 48 cali<br/>4 sztuki</p> |
|                                      |                                      |                                    |
| <p>Krok 1: Po zmierzeniu wymiarów zaznacz</p>  | <p>Krok 2: Nałóż klej budowlany na tylną</p>  | <p>Krok 3: Przymocuj je do ściany zgodnie z ich</p>  |

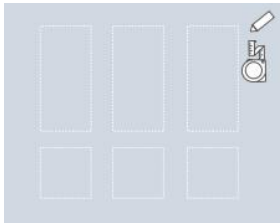
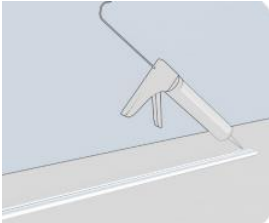
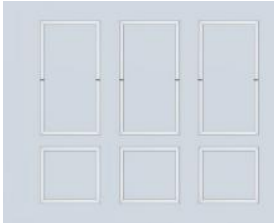
|  |                                      |   |
|--|--------------------------------------|---|
| <p>odpowiednie pozycje ołówkiem i linijką.</p> | <p>część listew wykończeniowych.</p> | <p>numeracją. Użyj taśmy klejącej, aby je przytrzymać, aż klej stwardnieje.</p> |
|--|--------------------------------------|---|

| <p style="text-align: center;"><b>JX36#-L1920</b></p>   |   |   |
|---|---|---|
|    |   |   |
|  <p><b>1</b> 24<br/>cale<br/>18 sztuk</p> |  <p><b>2</b> 27 cali<br/>6 sztuk</p> |  <p><b>3</b> 27 cali<br/>6 sztuk</p> |
|                                        |                                    |                                   |
| <p>Krok 1: Po zmierzeniu wymiarów zaznacz</p>   | <p>Krok 2: Nałóż klej budowlany na tylną</p>  | <p>Krok 3: Przymocuj je do ściany zgodnie z ich</p>   |

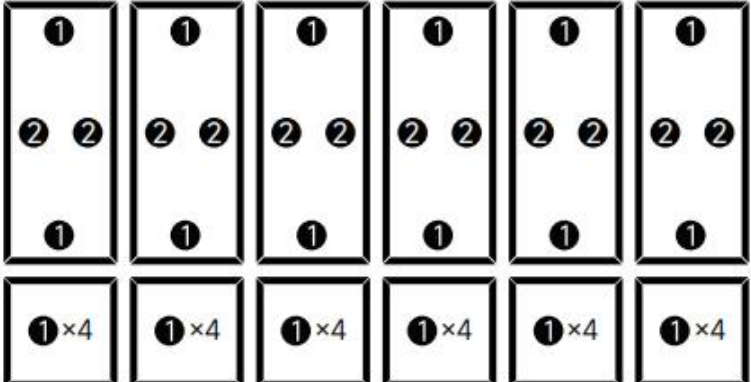
|   |                               |   |
|---|-------------------------------|---|
| odpowiednie pozycje ołówkiem i linijką. | część listew wykończeniowych. | numeracją. Użyj taśmy klejącej, aby je przytrzymać, aż klej wyschnie. |
|---|-------------------------------|---|

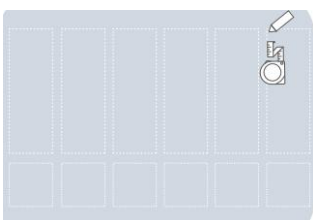
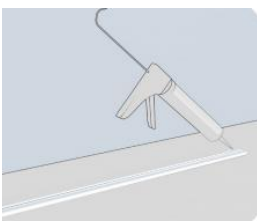
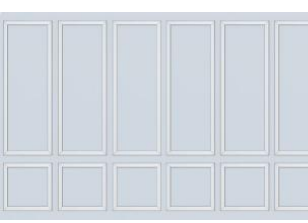





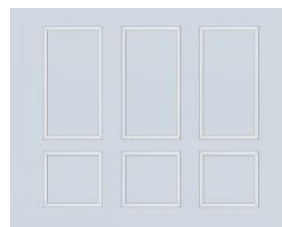
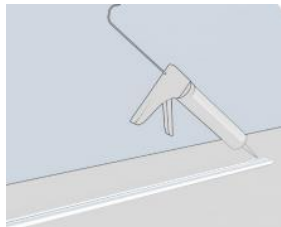
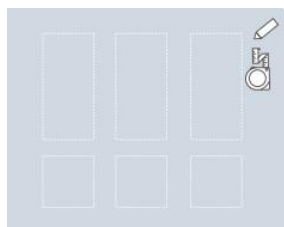
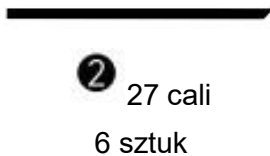
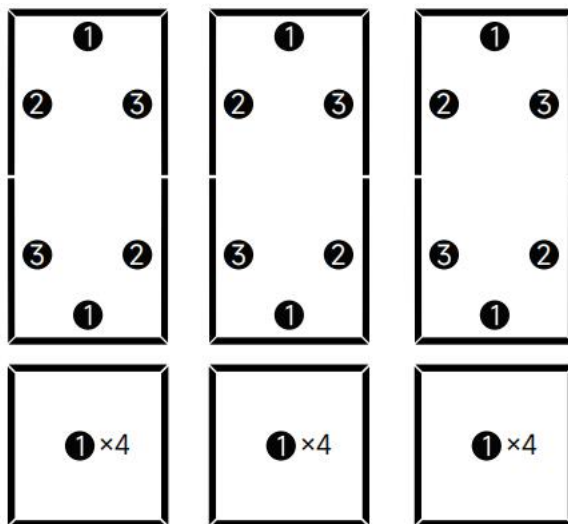

| <b>JX60#-L3842</b>   |   |  |
|--|---|--|
|                     |   |  |
| <br>cale<br>36 sztuk | <br>12 sztuk |  |
|                    |            |        |
| <p>Krok 1: Po zmierzeniu wymiarów zaznacz odpowiednie pozycje ołówkiem i linijką.</p>                | <p>Krok 2: Nałóż klej budowlany na tylną część listew wykończeniowych.</p>                    | <p>Krok 3: Przymocuj je do ściany zgodnie z ich numeracją. Użyj taśmy klejącej, aby je</p> |

przytrzymać, aż klej  
wyschnie.

### JX88#-L1920



|   |  |   |
|---|--|---|
| <p>Krok 1: Po zmierzeniu wymiarów zaznacz odpowiednie pozycje ołówkiem i linijką.</p> | <p>Krok 2: Nałóż klej budowlany na tylną część listew wykończeniowych.</p> | <p>Krok 3: Przymocuj je do ściany zgodnie z ich numeracją. Użyj taśmy klejącej, aby je przytrzymać, aż klej wyschnie.</p> |
|---|--|---|

| <b>JC956#-JC960-L2044</b>   |  |   |
|---|--|---|
|   |  |   |
|  <p><b>1</b> 31 cali<br/>12 sztuk</p>  |  <p><b>2</b> 27 cali<br/>6 sztuk</p>    |  <p><b>3</b> 27 cali<br/>6 sztuk</p>   |
|  <p><b>4</b> 18 cali<br/>6 sztuk</p> |  <p><b>5</b> 19 cali<br/>12 sztuk</p> |  <p><b>6</b> 19 cali<br/>6 sztuk</p> |
|                                      |                                       |   |

|   |   |   |
|---|---|---|
| <p><b>7</b> 19 cali<br/>6 sztuk</p>   | <p><b>8</b> 6 cali<br/>6 sztuk</p>  |   |
|       |  |   |
| <p>Krok 1: Po zmierzeniu wymiarów zaznacz odpowiednie pozycje ołówkiem i linijką.</p> | <p>Krok 2: Nałóż klej budowlany na tylną część listew wykończeniowych .</p>       | <p>Krok 3: Przymocuj je do ściany zgodnie z ich numeracją. Użyj taśmy klejącej, aby je przytrzymać, aż klej wyschnie.</p> |

## SUMMARY

Kluczem do montażu dekoracyjnych listew ściennych jest „wstępny pomiar, montaż w trakcie montażu i późniejsza naprawa”. Konieczne jest dopasowanie stanu ściany i narzędzi do materiału listew dekoracyjnych, ze szczególnym uwzględnieniem takich szczegółów, jak łączenie narożników wewnętrznych i zewnętrznych oraz dobór kleju, aby uzyskać „gładki, jednolity, solidny i trwały” efekt dekoracyjny i uniknąć przeróbek lub pogorszenia estetyki spowodowanego niewłaściwą obsługą.

**Producent:** Shanghaimuxinmuyeyouxiangongsi

**Adres:** Shuangchenglu 803nong11hao1602A-1609shi, baoshanqu, szanghaj 200000 CN.

**Importowane do AUS:** SIHAO PTY LTD. 1 ROKEVA  
STREETEASTWOOD  
NSW 2122 Australia

**Importowane do USA:** Sanven Technology Ltd. Suite 250, 9166 Anaheim  
Miejsce, Rancho Cucamonga, CA 91730

|           |            |
|-----------|------------|
| <b>UK</b> | <b>REP</b> |
|-----------|------------|

YH CONSULTING LIMITED. C/O YH Consulting  
Limited Office 147, Centurion House, London  
Road, Staines-upon-Thames, Surrey, TW18 4AX

|           |            |
|-----------|------------|
| <b>EC</b> | <b>REP</b> |
|-----------|------------|

E-CrossStu GmbH  
Mainzer Landstr.69,  
60329 Frankfurt am Main.



# **VEVOR**

**Upgrade · The Home Creator Way**

## **WANDLIJST AFWERKING**

**MODEL: JX36#-L2438/JX88#-L2690/JX88#-L2165/  
JX36#-L1920/JX60#-L3842/JX88#-L1920/  
JC956#-JC960-L2044**



Model: JX36#-L2438

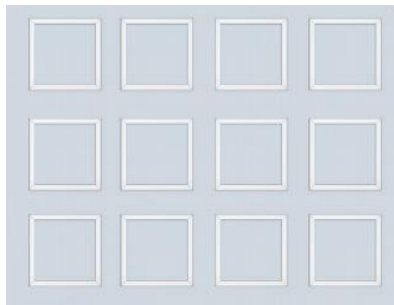

Model: JX88#-L2690

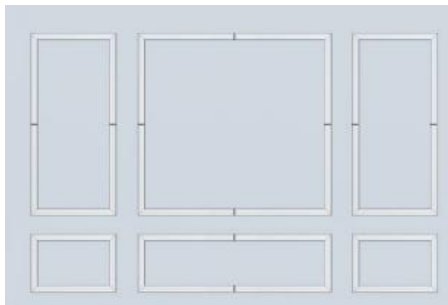

Model: JX88#-L2165

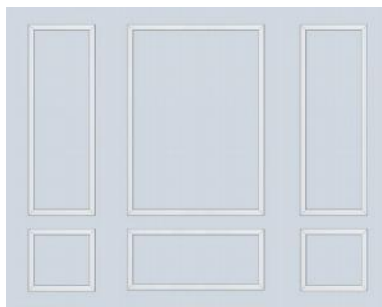

Model: JC956#-JC960-L2044

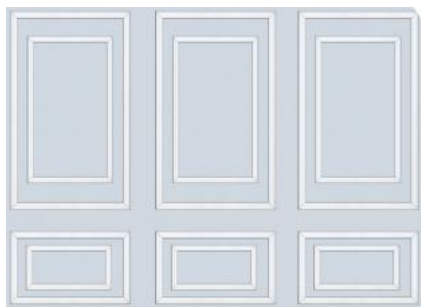

Model: JX36#-L1920

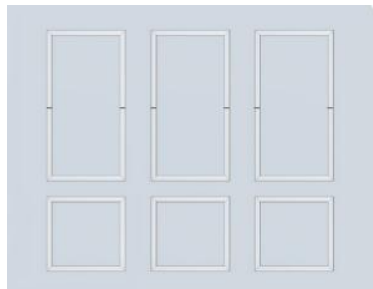

Model: JX60#-L3842

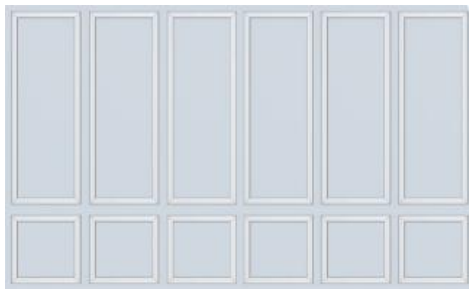

Model: JX88#-L1920

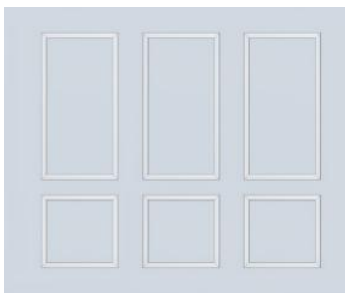

Dit is de originele handleiding. Lees alle instructies zorgvuldig door voordat u het product gebruikt. VEVOR behoudt zich het recht voor om de gebruiksaanwijzing duidelijk te interpreteren. Het uiterlijk van het product is afhankelijk van het product dat u hebt ontvangen. Neemt u het ons niet kwalijk dat we u niet meer op de hoogte stellen van eventuele technologische of software-updates voor ons product.









Waarschuwing: om het risico op letsel te verminderen, moet de gebruiker de gebruiksaanwijzing zorgvuldig lezen.

### **Wandlijsten afmetingen**



Meet uw muur op voordat u bestelt om ervoor te zorgen dat de juiste hoeveelheid wordt besteld

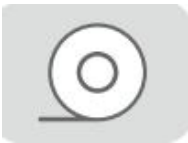

Hartelijk dank voor uw keuze voor deze wandlijst. Lees de instructies aandachtig door voordat u deze gebruikt. Deze informatie helpt u de best mogelijke resultaten te bereiken.

## TOOLS REQUIREMENT INTRODUCTION

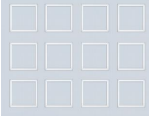
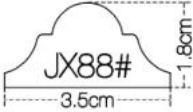
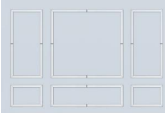
|   |   |   |
|---|---|---|
|  |  |  |
| Bouw<br>Lijm  | Meetlint  | Potlood   |
|  |  |  |
| Handdoek  | Markeringstape  | Handschoenen  |

## SAVE THIS MANUAL

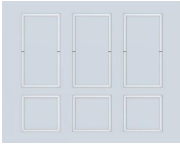
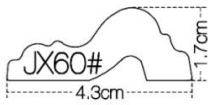
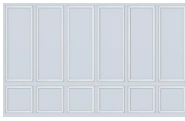
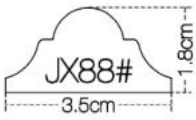
| Model       | Strokenpatroon  | Collage-effect  |
|-------------|---|---|
| JX36#-L2438 |   |   |
| JX88#-L2690 |  |  |
| JX88#-L2165 |   |  |

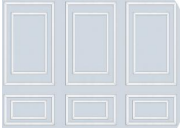
|                    |   |   |
|--------------------|---|---|
| JX36#-L1920        |  |   |
| JX60#-L3842        |  |  |
| JX88#-L1920        |  |  |
| JC956#-JC960-L2044 |  |  |

## BEFORE INSTALLATION: FOUNDATION PREPARATION

### Inspectie van de staat van de muur: zorg ervoor dat de "fundering gekwalificeerd is"

Voor de installatie van decoratieve strips zijn vlakke, droge en stevige muren nodig. Deze moeten in een vroeg stadium één voor één worden gecontroleerd:

**Vlakheid:** Gebruik een liniaal van 2 meter om het muuroppervlak te testen, met een fout van  $\leq 3$  mm. Als er uitstekende delen, kuilen of scheuren in het muuroppervlak zitten, breng dan eerst plamuur aan om het te egaliseren (het is aan te raden om waterbestendige plamuur te gebruiken, vooral in vochtige ruimtes zoals badkamers en keukens). Na droging, polijst u het met schuurpapier glad.

**Droogtegraad:** Het nieuwe muuroppervlak moet volledig droog zijn (aanbevolen wordt om minimaal 7 dagen te ventileren na het verven van

latexverfwanden, en 28 dagen bij cementmuren), om te voorkomen dat er later vocht op het muuroppervlak terugkomt, waardoor de decoratieve strips los kunnen raken of kunnen gaan schimmelen.

Reiniging: Verwijder stof, olievlekken en zwevende as van het muuroppervlak. Veeg de muur af met een vochtige doek en laat aan de lucht drogen om te voorkomen dat de lijm minder goed hecht.

## INSTALLATION STEPS

### JX36#-L2438

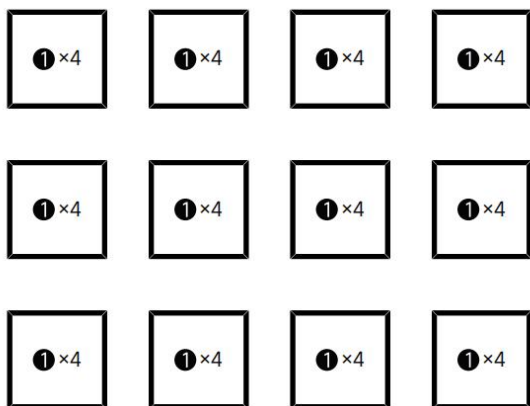

**1** 20"  
48 stuks

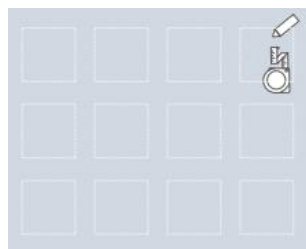

Stap 1: Nadat u de afmetingen hebt gemeten, markeert u de juiste posities met een

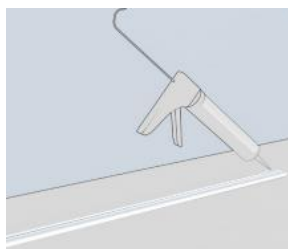

Stap 2: Breng montagelijm aan op de achterkant van de sierlijsten .

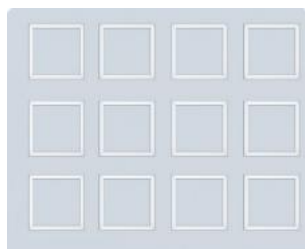

Stap 3: Bevestig ze volgens hun nummer aan de muur. Gebruik tape om ze op hun

potlood en een liniaal.

plaats te houden totdat de lijm is uitgehard.

### JX88#-L2690

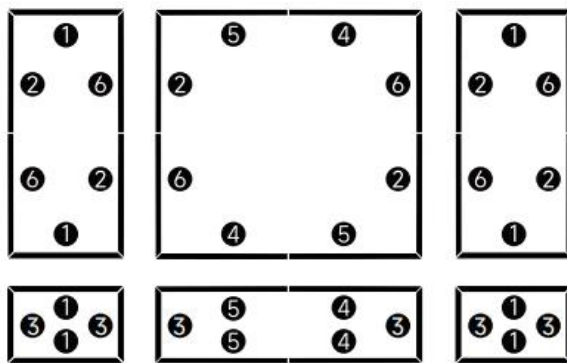

1 31 "

8 stuks



2 31,5 inch

6 stuks



3 24 "

6 stuks



4 36 "

4 stuks



5 36 "

4 stuks





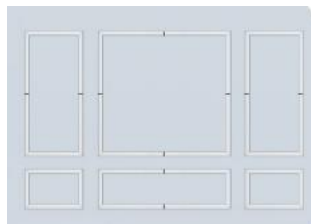
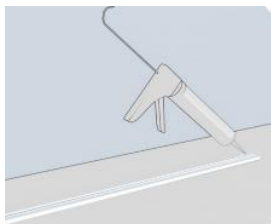
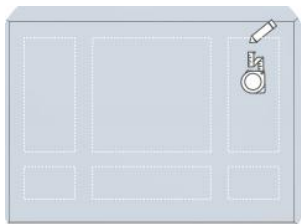

6 31,5 inch

6 stuks

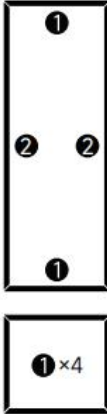
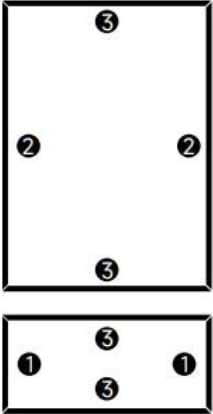
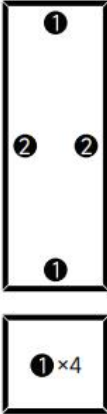

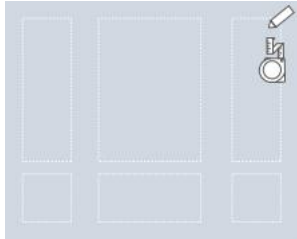
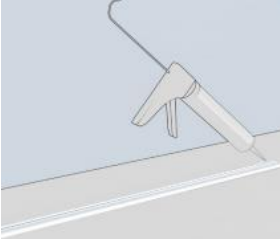
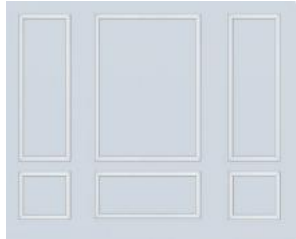

|  |  |  |
|--|--|--|
| <p>Stap 1: Nadat u de afmetingen hebt gemeten, markeert u de juiste posities met een potlood en een liniaal.</p> | <p>Stap 2: Breng montagelijm aan op de achterkant van de sierlijsten .</p> | <p>Stap 3: Bevestig ze volgens hun nummer aan de muur. Gebruik tape om ze op hun plaats te houden totdat de lijm is uitgehard.</p> |
|--|--|--|

| <p style="text-align: center;"><b>JX88#-L2165</b></p>  |   |   |
|--|---|---|
|   |    |    |
|  <p style="text-align: center;"><b>1</b> 23 "</p> <p style="text-align: center;">14 stuks</p> |  <p style="text-align: center;"><b>2</b> 56,3 "</p> <p style="text-align: center;">6 stuks</p> |  <p style="text-align: center;"><b>3</b> 48 "</p> <p style="text-align: center;">4 stuks</p> |
|    |    |   |
| <p>Stap 1: Nadat u de afmetingen hebt</p>  | <p>Stap 2: Breng montagelijm aan op</p>   | <p>Stap 3: Bevestig ze aan de muur volgens</p>  |

|  |                                   |  |
|--|-----------------------------------|--|
| gemeten, markeert u de juiste posities met een potlood en een liniaal. | de achterkant van de sierlijsten. | hun nummers. Gebruik tape om ze op hun plaats te houden totdat de lijm is uitgehard. |
|--|-----------------------------------|--|

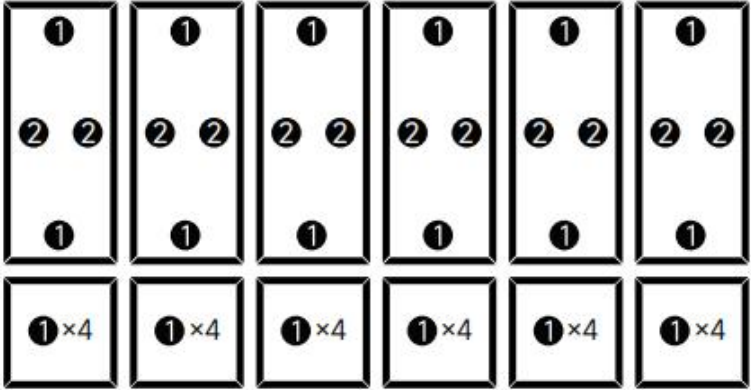

| <b>JX36#-L1920</b>                   |                                     |   |
|--------------------------------------|-------------------------------------|---|
|                                      |                                     |   |
| <p><b>1</b> 24 "</p> <p>18 stuks</p> | <p><b>2</b> 27 "</p> <p>6 stuks</p> | <p><b>3</b> 27 "</p> <p>6 stuks</p>     |
|                                      |                                     |   |
| Stap 1: Nadat u de afmetingen hebt   | Stap 2: Breng montagelijm aan op    | Stap 3: Bevestig ze aan de muur volgens |

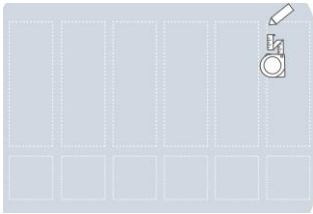
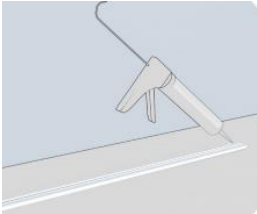
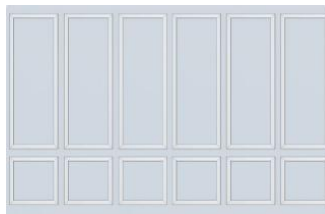
|  |                                   |  |
|--|-----------------------------------|--|
| gemeten, markeert u de juiste posities met een potlood en een liniaal. | de achterkant van de sierlijsten. | hun nummers. Gebruik tape om ze op hun plaats te houden totdat de lijm is uitgehard. |
|--|-----------------------------------|--|





| <b>JX60#-L3842</b>   |  |  |
|--|--|--|
|                               |  |  |
| <br><b>1</b> 24 "<br>36 stuks | <br><b>2</b> 54 "<br>12 stuks |  |
|                              |                             |  |
| Stap 1: Nadat u de afmetingen hebt gemeten, markeert u de  | Stap 2: Breng montagelijm aan op de achterkant van de  | Stap 3: Bevestig ze aan de muur volgens hun nummers. Gebruik                         |



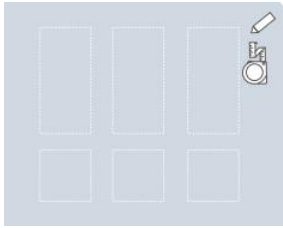
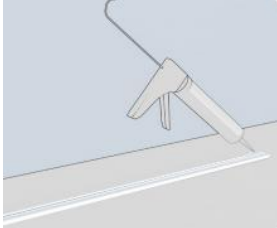
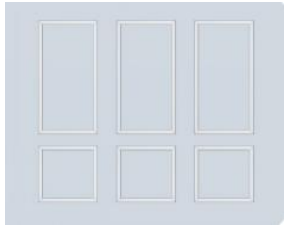

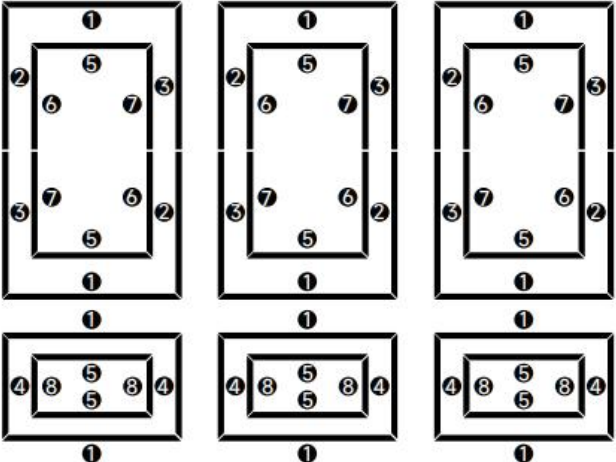
|   |              |   |
|---|--------------|---|
| juiste posities met een potlood en een liniaal. | sierlijsten. | tape om ze op hun plaats te houden totdat de lijm is uitgehard. |
|---|--------------|---|

**JX88#-L1920**

|  |   |   |
|--|---|---|
| <br><b>1</b> 24 "<br>18 stuks | <br><b>2</b> 27 "<br>6 stuks | <br><b>3</b> 27 "<br>6 stuks |
|--|---|---|

|  |  |   |
|--|--|---|
|                                   |  |    |
| <p>Stap 1: Nadat u de afmetingen hebt gemeten, markeert u de juiste posities met een potlood en een liniaal.</p> | <p>Stap 2: Breng montagelijm aan op de achterkant van de sierlijsten.</p>        | <p>Stap 3: Bevestig ze aan de muur volgens hun nummers. Gebruik tape om ze op hun plaats te houden totdat de lijm is uitgehard.</p> |

|  |   |   |
|--|---|---|
| <b>JC956#-JC960-L2044</b>  |   |   |
|                                        |   |   |
|  <p><b>1</b> 31 "</p> <p>12 stuks</p> |  <p><b>2</b> 27 "</p> <p>6 stuks</p> |  <p><b>3</b> 27 "</p> <p>6 stuks</p> |

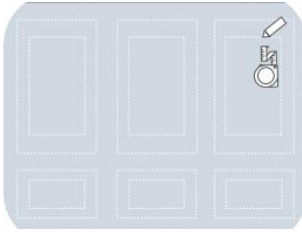
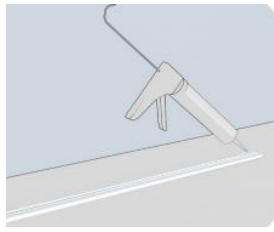
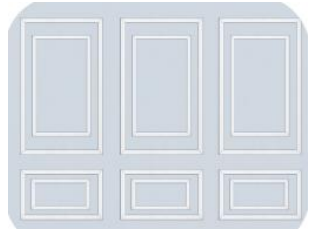
|   |  |  |
|---|--|--|
|  <p><b>4</b> 18 "</p> <p>6 stuks</p> |  <p><b>5</b> 19 "</p> <p>12 stuks</p> |  <p><b>6</b> 19 "</p> <p>6 stuks</p>              |
|  <p><b>7</b> 19 "</p> <p>6 stuks</p> |  <p><b>8</b> 6 "</p> <p>6 stuks</p>   |  |
|                                       |                                       |    |
| <p>Stap 1: Nadat u de afmetingen hebt gemeten, markeert u de juiste posities met een potlood en een liniaal.</p>      | <p>Stap 2: Breng montagelijm aan op de achterkant van de sierlijsten .</p>   | <p>Stap 3: Bevestig ze volgens hun nummer aan de muur. Gebruik tape om ze op hun plaats te houden totdat de lijm is uitgehard.</p> |

## SUMMARY

De kern van het installeren van decoratieve wandstrips is "vooraf meten, tussentijdse bevestiging en latere reparatie". Het is noodzakelijk om de muromstandigheden en het gereedschap af te stemmen op het materiaal van de decoratieve strips, met bijzondere aandacht voor details zoals het verbinden van binnen- en buitenhoeken en de keuze van de lijm. Dit om een "glad, naadloos, stevig en duurzaam" decoratief effect te bereiken en herbewerking of esthetische achteruitgang door onjuist gebruik te

voorkomen.

**Fabrikant:** Shanghaimuxinmuyeyouxiangongsi

**Adres:** Shuangchenglu 803nong11hao1602A-1609shi, baoshanqu, shanghai 200000 CN.

**Geïmporteerd naar AUS:** SIHAO PTY LTD. 1 ROKEVA  
STREETEASTWOOD  
NSW 2122 Australië

**Geïmporteerd naar de VS:** Sanven Technology Ltd. Suite 250, 9166  
Anaheim  
Plaats, Rancho Cucamonga, CA 91730

|           |            |
|-----------|------------|
| <b>UK</b> | <b>REP</b> |
|-----------|------------|

YH CONSULTING LIMITED. C/O YH Consulting  
Limited Office 147, Centurion House, London  
Road, Staines-upon-Thames, Surrey, TW18 4AX

|           |            |
|-----------|------------|
| <b>EC</b> | <b>REP</b> |
|-----------|------------|

E-CrossStu GmbH  
Mainzer Landstr.69,  
60329 Frankfurt am Main.



# **VEVOR**

**Upgrade · The Home Creator Way**

## **VÄGGLISTLIST**

**MODELL: JX36#-L2438/JX88#-L2690/JX88#-L2165/  
JX36#-L1920/JX60#-L3842/JX88#-L1920/  
JC956#-JC960-L2044**



Modell: JX36#-L2438

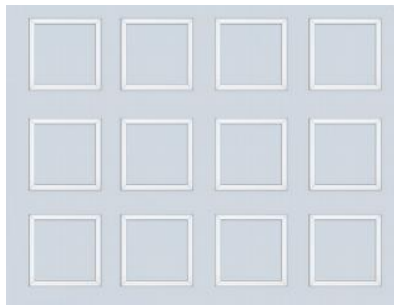

Modell: JX88#-L2690

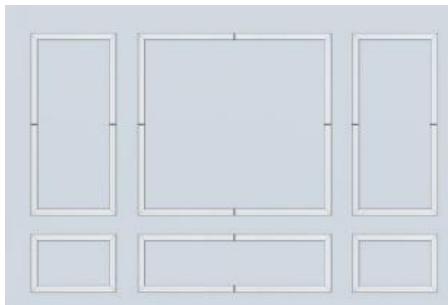

Modell: JX88#-L2165

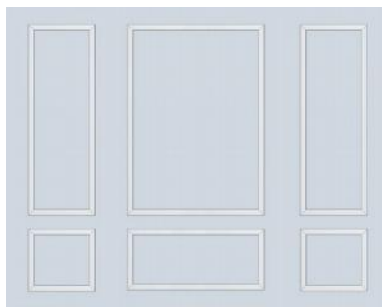

Modell: JC956#-JC960-L2044

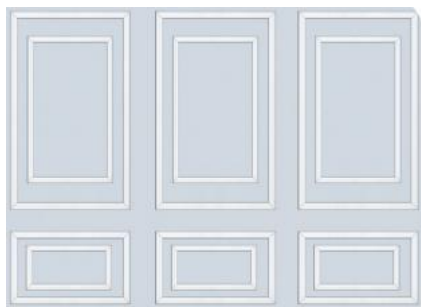

Modell: JX36#-L1920

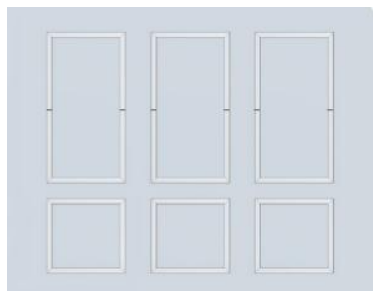

Modell: JX60#-L3842



Modell: JX88#-L1920

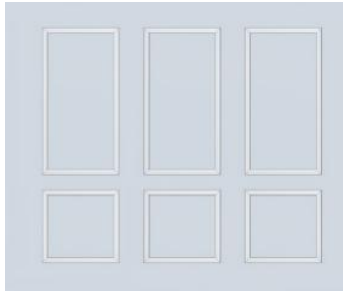

Detta är originalinstruktionerna, vänligen läs alla instruktioner noggrant innan du använder produkten. VEVOR förbehåller sig en tydlig tolkning av vår användarmanual. Produktens utseende ska vara beroende av den produkt du mottagit. Vi ber om ursäkt för att vi inte kommer att informera dig igen om det finns några teknik- eller programuppdateringar för vår produkt.









Varning – För att minska risken för skador måste användaren läsa instruktionsmanualen noggrant.

## VÄGGLISTERMÅTT





Mät din vägg innan du beställer för att säkerställa att rätt beställd mängd

Tack så mycket för att du valde denna vägglist. Läs alla instruktioner innan du använder den. Informationen hjälper dig att uppnå bästa möjliga resultat.

## TOOLS REQUIREMENT INTRODUCTION

|   |   |   |
|---|---|---|
|  |  |  |
| Byggnation<br>Lim   | Måttband  | Penna   |
|  |  |  |
| Handduk   | Märkningstejp   | Handskar  |

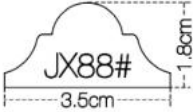
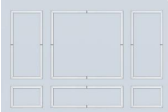
## SAVE THIS MANUAL

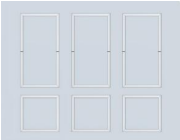
| Modell      | Remsmönster   | Collageeffekt   |
|-------------|---|---|
| JX36#-L2438 |    |   |
| JX88#-L2690 |  |  |
| JX88#-L2165 |   |  |
| JX36#-L1920 |  |  |

|                    |  |  |
|--------------------|--|--|
| JX60#-L3842        |  |  |
| JX88#-L1920        |  |  |
| JC956#-JC960-L2044 |  |  |

## BEFORE INSTALLATION: FOUNDATION PREPARATION

### Inspektion av väggens skick: Säkerställ att "grunden är kvalificerad"

Installationen av dekorlister är beroende av plana, torra och robusta väggar och behöver kontrolleras en efter en i ett tidigt skede:

**Planhet:** Använd en 2-meterslinjal för att testa väggytan, med ett fel på  $\leq 3$  mm. Om det finns utskjutande delar, fördjupningar eller sprickor på väggytan, applicera först spackel för att jämna ut den (det rekommenderas att använda vattenbeständig spackel, särskilt i fuktiga utrymmen som badrum och kök). Använd sandpapper för att polera den slät efter torkning.

**Torkgrad:** Den nya väggytan ska vara helt torr (det rekommenderas att ventileras i minst 7 dagar efter målning av latexfärgade väggar och låta cementväggar vädras i minst 28 dagar) för att undvika att fukt återfår väggytan i senare skede, vilket kan orsaka att dekorlisterna faller av eller möglar.

**Renlighet:** Avlägsna damm, oljefläckar och flytande aska från väggytan. Använd en fuktig trasa för att torka och lufttorka för att förhindra att limmet vidhäftar mindre.

## INSTALLATION STEPS

### JX36#-L2438

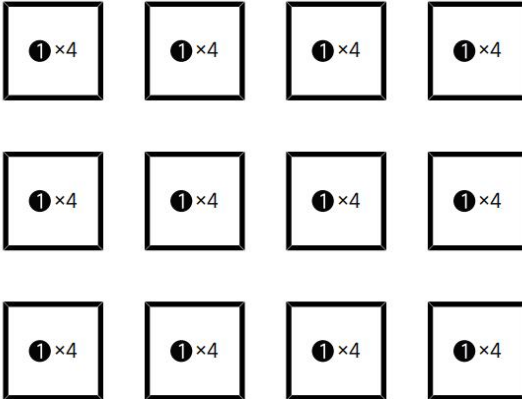

1 20"

48 stycken

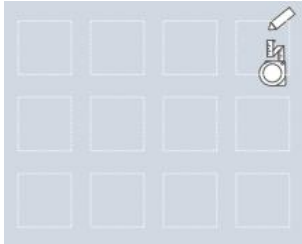

Steg 1: Efter att ha mätt måtten, använd en penna och linjal för att markera rätt positioner.

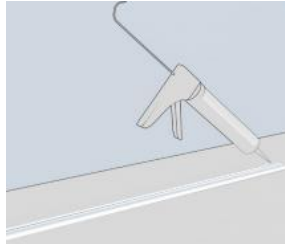

Steg 2: Applicera konstruktionslim på baksidan av listerna .

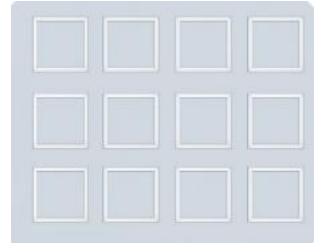

Steg 3: Fäst dem på väggen enligt deras antal. Använd tejp för att hålla dem på plats tills limmet härdar.

### JX88#-L2690

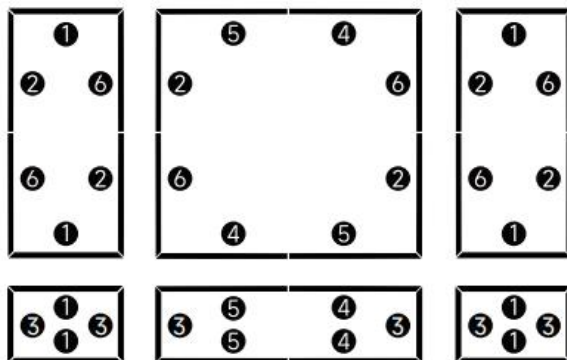

1 31 "

8 stycken



2 31,5 "

6 stycken



3 24 "

6 stycken



4 36 "

4 stycken



5 36 "

4 stycken



6 31,5 "

6 stycken

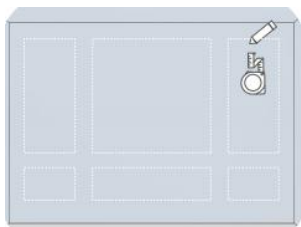

Steg 1: Efter att ha mätt måtten, använd en penna och linjal för att markera rätt positioner.

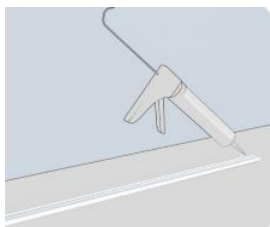

Steg 2: Applicera konstruktionslim på baksidan av listerna .

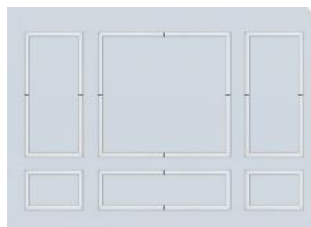

Steg 3: Fäst dem på väggen enligt deras antal. Använd tejp för att hålla dem på plats tills limmet härdar.

**JX88#-L2165**

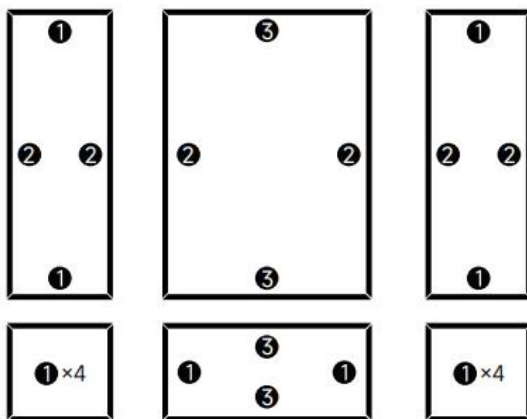

1 23 "

14 stycken



2 56,3 "

6 stycken



3 48 "

4 stycken

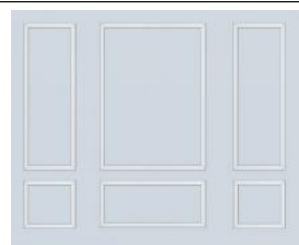
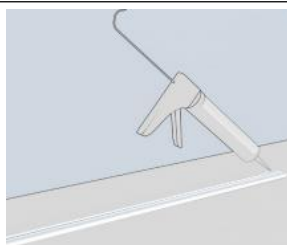
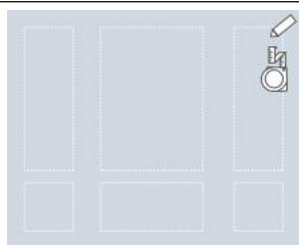

Steg 1: Efter att ha mätt måtten, använd en penna och linjal för att markera rätt positioner.

Steg 2: Applicera konstruktionslim på baksidan av listerna.

Steg 3: Fäst dem på väggen enligt deras antal. Använd tejp för att hålla dem på plats tills limmet härdar.

**JX36#-L1920**

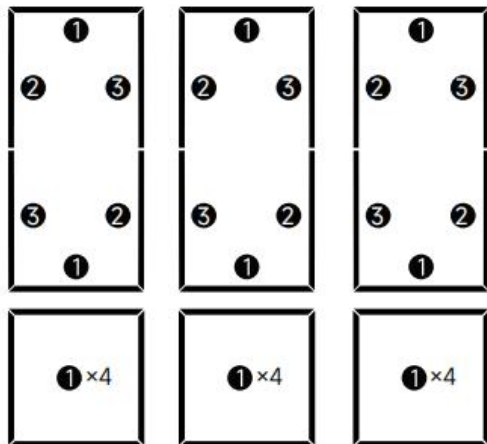

**1** 24 "

18 stycken



**2** 27 "

6 stycken



**3** 27 "

6 stycken

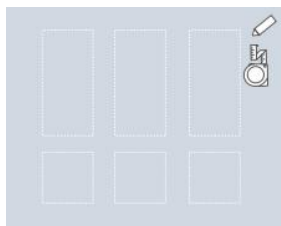

Steg 1: Efter att ha mätt måtten, använd en penna och linjal för att markera rätt positioner.

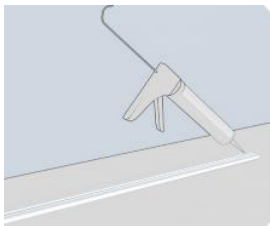

Steg 2: Applicera konstruktionslim på baksidan av listerna.

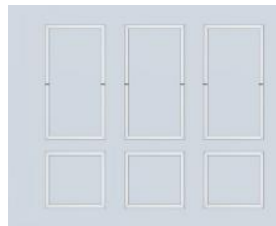

Steg 3: Fäst dem på väggen enligt deras antal. Använd tejp för att hålla dem på plats tills limmet härdar.

**JX60#-L3842**

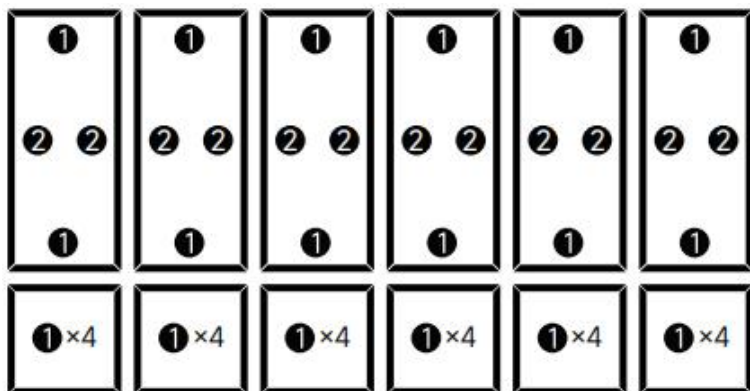

1 24 "

36 stycken



2 54 "

12 stycken

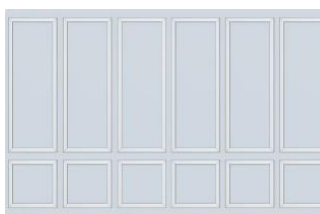
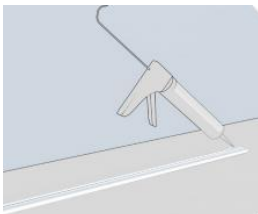

Steg 1: Efter att ha mätt måtten, använd en penna och linjal för att markera rätt positioner.

Steg 2: Applicera konstruktionslim på baksidan av listerna.

Steg 3: Fäst dem på väggen enligt deras antal. Använd tejp för att hålla dem på plats tills limmet härdar.

**JX88#-L1920**

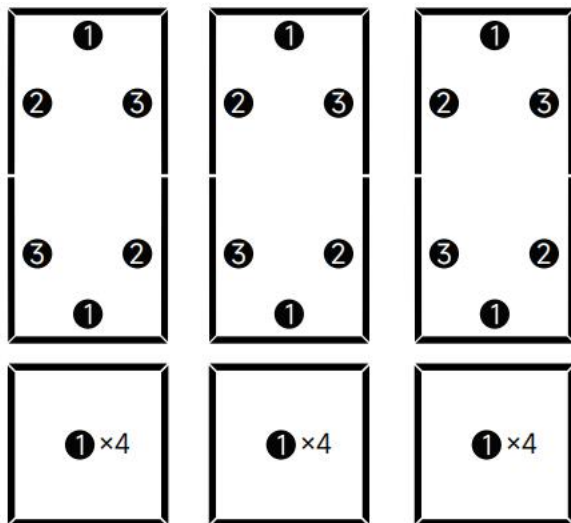

1 24 "

18 stycken



2 27 "

6 stycken



3 27 "

6 stycken

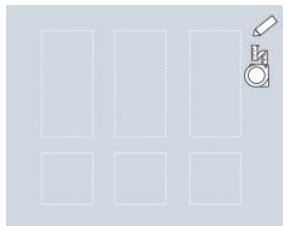

Steg 1: Efter att ha mätt måtten, använd en penna och linjal för att markera rätt positioner.

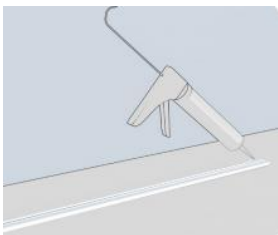

Steg 2: Applicera konstruktionslim på baksidan av listerna.

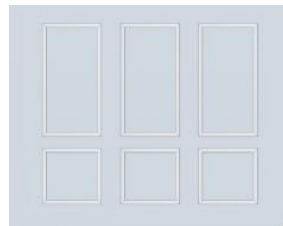

Steg 3: Fäst dem på väggen enligt deras antal. Använd tejp för att hålla dem på plats tills limmet härdar.

JC956#-JC960-L2044

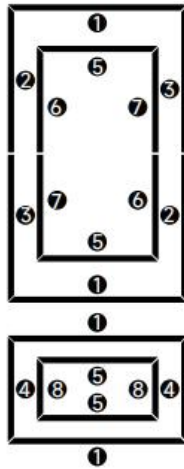
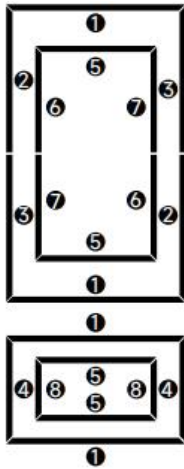

**1** 31 "

12 stycken



**2** 27 "

6 stycken



**3** 27 "

6 stycken



**4** 18 "

6 stycken



**5** 19 "

12 stycken



**6** 19 "

6 stycken



**7** 19 "

6 stycken



**8** 6 "

6 stycken

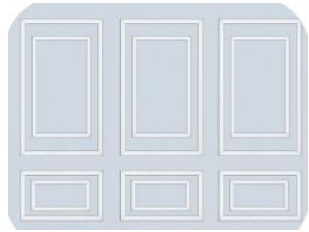
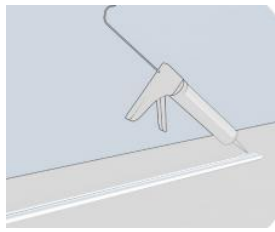
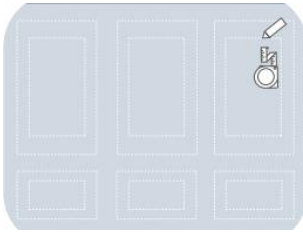

|  |   |   |
|--|---|---|
| <p>Steg 1: Efter att ha mätt måtten, använd en penna och linjal för att markera rätt positioner.</p> | <p>Steg 2: Applicera konstruktionslim på baksidan av listerna .</p> | <p>Steg 3: Fäst dem på väggen enligt deras antal. Använd tejp för att hålla dem på plats tills limmet härdar.</p> |
|--|---|---|

## SUMMARY

Kärnan i installationen av väggdekorationslister är "förmätning, fixering på medellång sikt och senare reparation". Det är nödvändigt att matcha väggens skick och verktyg efter materialet i dekorationslisterna, särskilt med uppmärksamhet på detaljer som invändig och utvändig hörnskarvning och val av lim, för att uppnå en "slät, sömlös, fast och hållbar" dekorativ effekt och undvika omarbetning eller estetisk försämring på grund av felaktig användning.

**Tillverkare:** Shanghaimuxinmuyeyouxiangongsi

**Adress:** Shuangchenglu 803nong11hao1602A-1609shi, baoshanqu, Shanghai 200 000 kanadensiska republiken.

**Importerad till Australien:** SIHAO PTY LTD. 1 ROKEVA  
STREETEASTWOOD  
NSW 2122 Australien

**Importerad till USA:** Sanven Technology Ltd. Suite 250, 9166 Anaheim

Plats, Rancho Cucamonga, Kalifornien 91730

|           |            |
|-----------|------------|
| <b>UK</b> | <b>REP</b> |
|-----------|------------|

YH CONSULTING LIMITED. C/O YH Consulting  
Limited Office 147, Centurion House, London  
Road, Staines-upon-Thames, Surrey, TW18 4AX

|           |            |
|-----------|------------|
| <b>EC</b> | <b>REP</b> |
|-----------|------------|

E-CrossStu GmbH  
Mainzer Landstr.69,  
60329 Frankfurt am Main.

