

VEVOR

Affordable. Reliable. Home Improvement.

STEERING WHEEL STAND

MODEL:6001

VEVOR

Affordable. Reliable. Home Improvement.

STEERING WHEEL STAND

Model:6001



This is the original instruction, please read all manual instructions carefully before operating. VEVOR reserves a clear interpretation of our user manual. The appearance of the product shall be subject to the product you received. Please forgive us that we won't inform you again if there are any technology or software updates on our product.





Warning-To reduce the risk of injury, user must read instructions manual carefully.



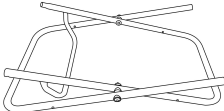
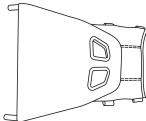
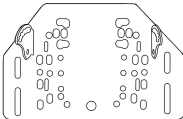

Attentions



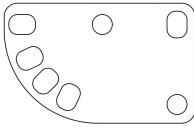
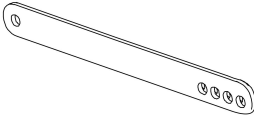
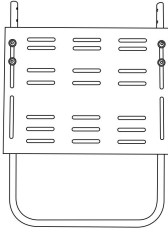
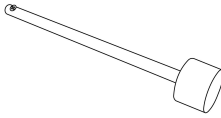
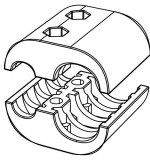

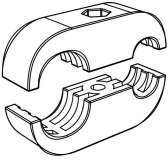
- Please install and use the stand according to instruction.
 - Please install moderately, avoid strong vibration.
 - Don't keep in humid conditions, high temperatures, or a dusty location.
 - The product structure is flexible, wear work gloves during assembly.
- Please take care of a hurting hand when installing .
- Children should be under adult supervision when using the product.

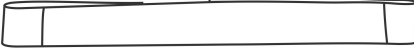
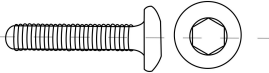
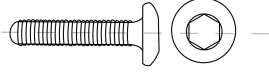
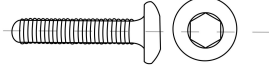
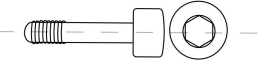
Save the manual.

Part List			
Code	Picture	Name	QTY.
1		Main Bracket	1
2		Back of head	1
3		Steering Wheel Panel	1
4		U-shaped part	1

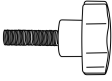
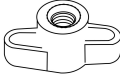
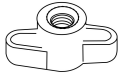
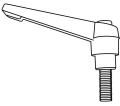
5		6001split pedal frame-U shaped	1
6		Adjust connection part for the pedal frame	2
7		Frame connector	4
8		6001split pedal panel	1
9		Anti-overturning support rod	1
10		Plastic fasteners (25/12)	1

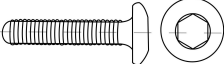
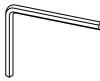
11		Plastic fasteners (25/16)	2
12		Tie-down strap	6
13		Lumbar support belt	1
A		Screw M8×20	2+1
B		Screw M6×25	8+1
C		Screw M6×35	4+1
D		Screw M6×35	4+1
E		Lock nut M6	8+1
F		Flange nut M6	8+6

G		Torx handle screw M6×15	2
H		Slotted Thumb Nut M6	2
I		Slotted Thumb Nut M8	2
J		L-shaped wrench M8×16	2
K		Flange nut M8	2+1
L		Screw M6×16	12
M		Hex wrench 5mm	1
N		open-end Spanner 10-13	1

Note: 12pcs screws M6*16 and 6pcs nuts M6 are complimentary.

★ For the list of seat kits and installation, please refer to the seat installation procedure manual attachment.

STEP 1:

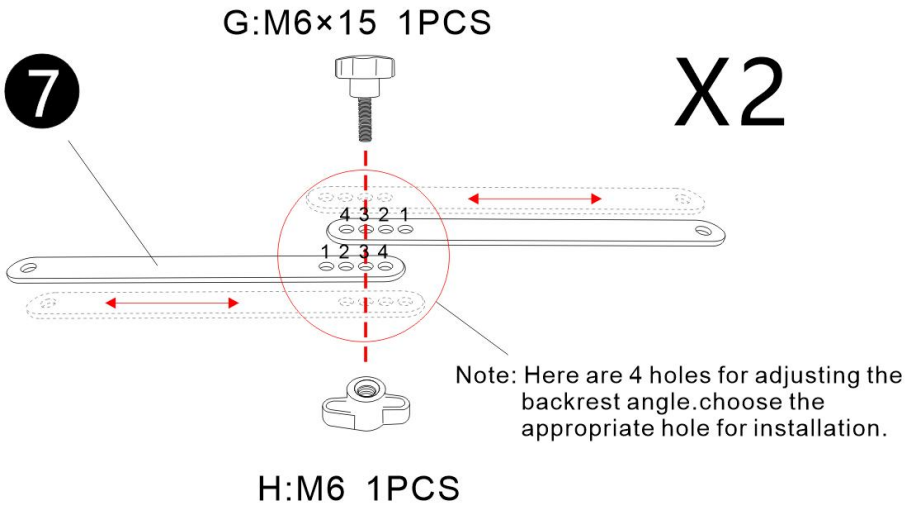

STEP 2:

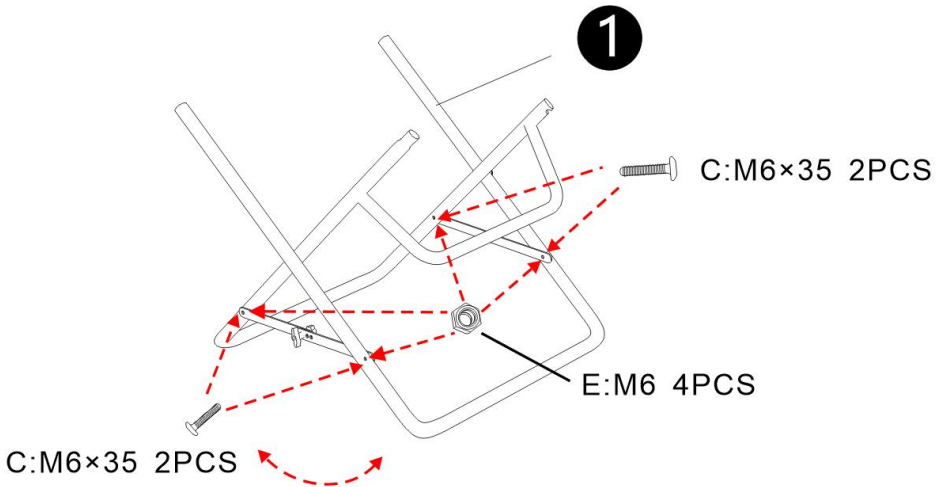

STEP 3:

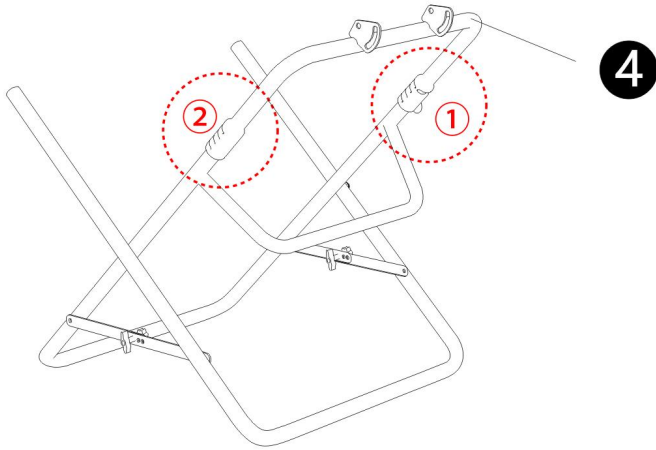

① **First insert 4 into the left side of the frame tube.**



step1: press the button spring at the long side of 4,insert the long side of 4 into the frame 1,when hearing a "click" sound, the marble slides into the main frame slot.

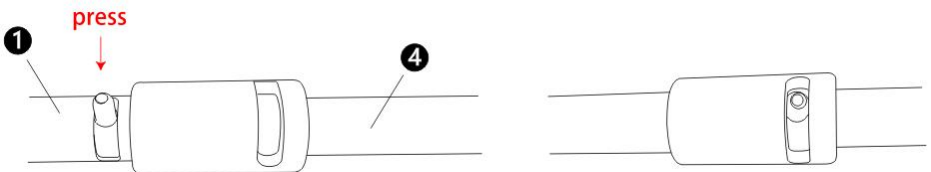

step2: press the button spring again,slide the long side buckle tube to the main frame, when hearing a "click" sound, the marble slides into the buckle tube slot.

②Then attach 4 to the other side of the frame tube.

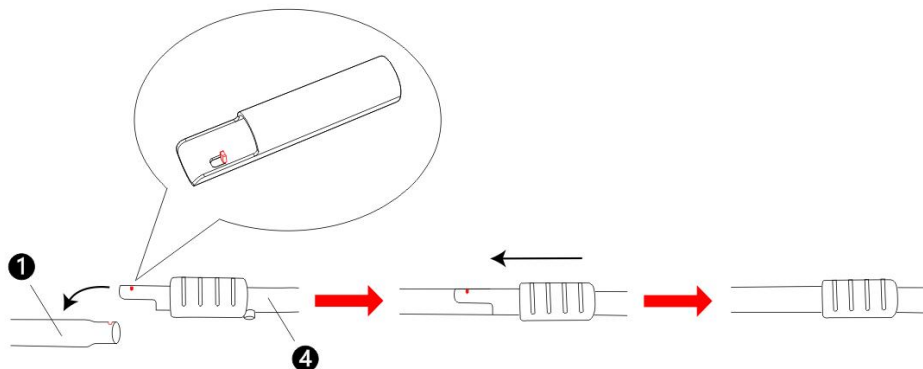

step3: Put the bump of the short side 4 into the slot of the main frame, and slide the buckle tube of the short end into the main frame

STEP 4:

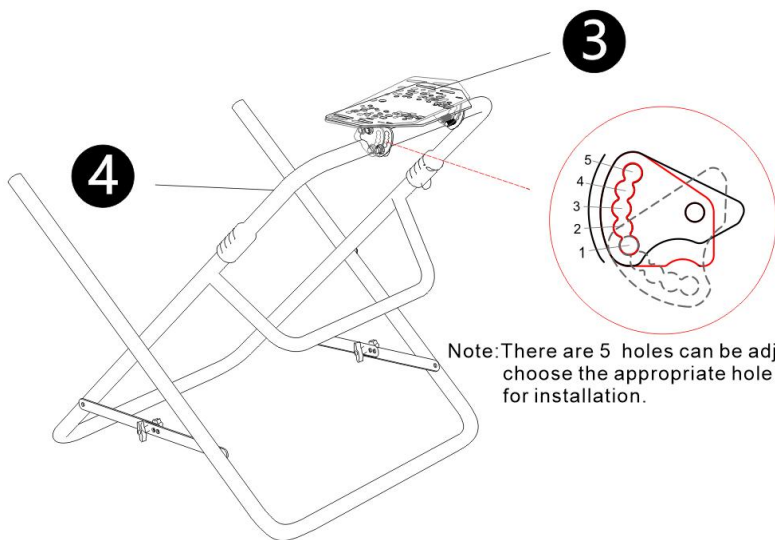

Note: There are 5 holes can be adjusted. choose the appropriate hole for installation.

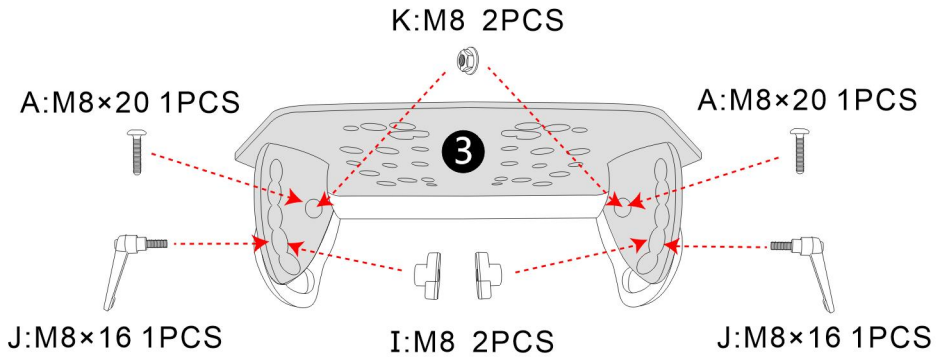

STEP 5:

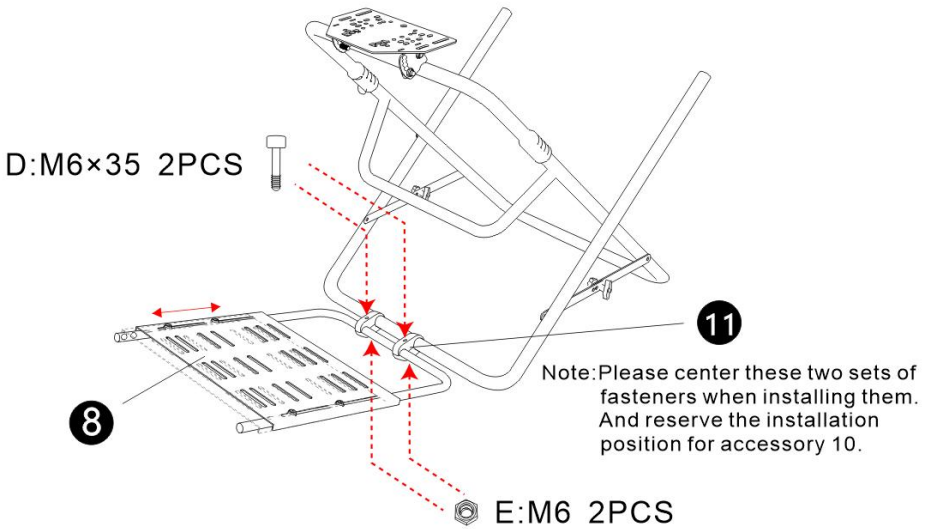

STEP 6:

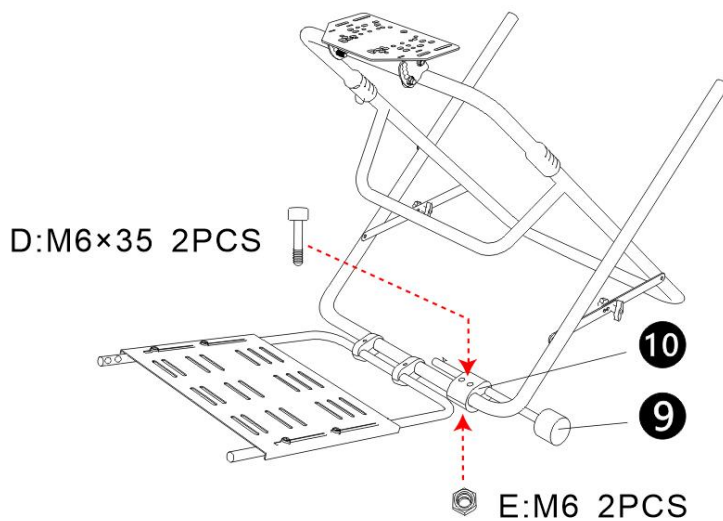

STEP 7:

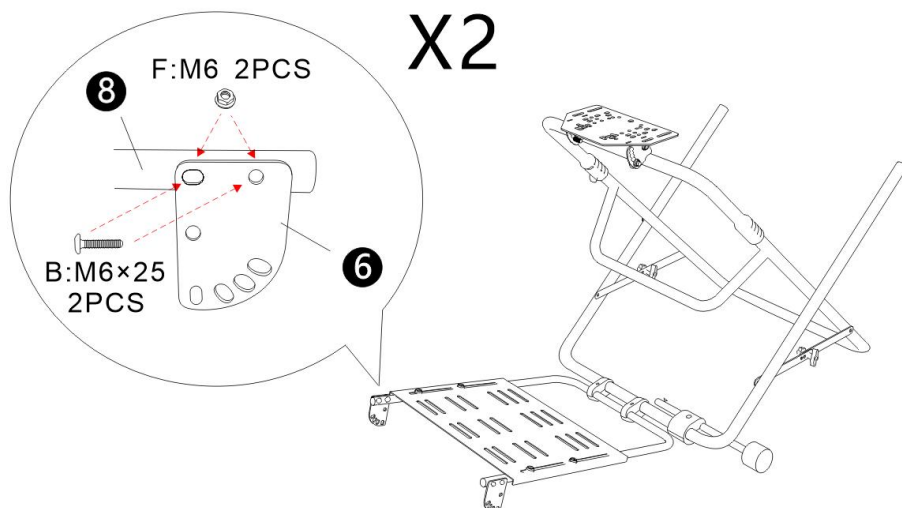

STEP 8:

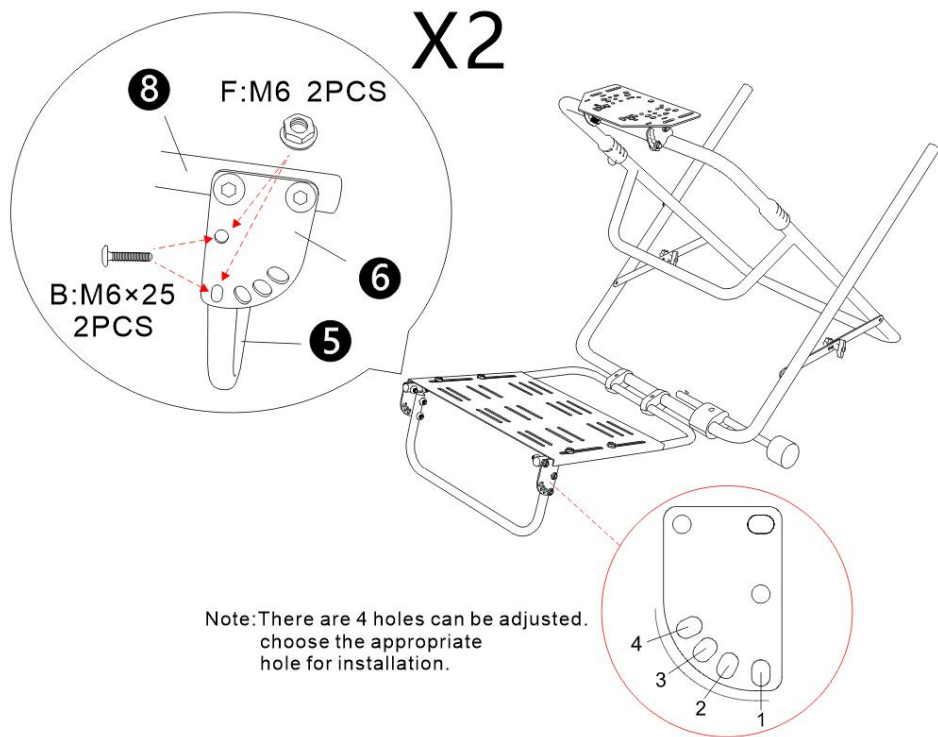

STEP 9:

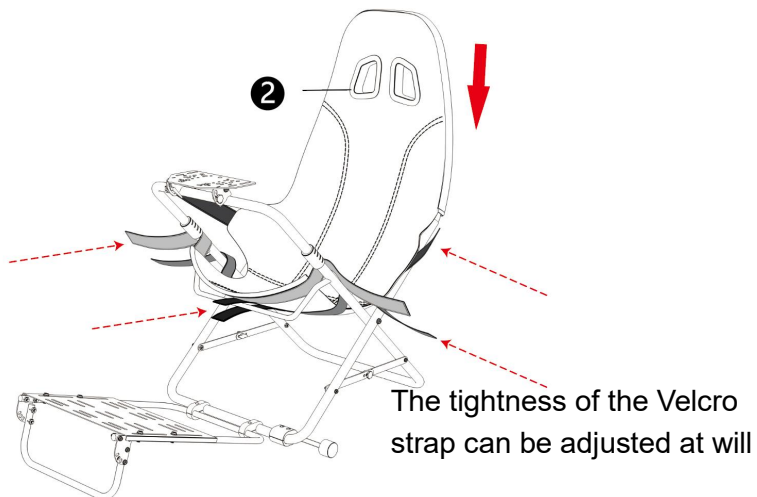

STEP 10:

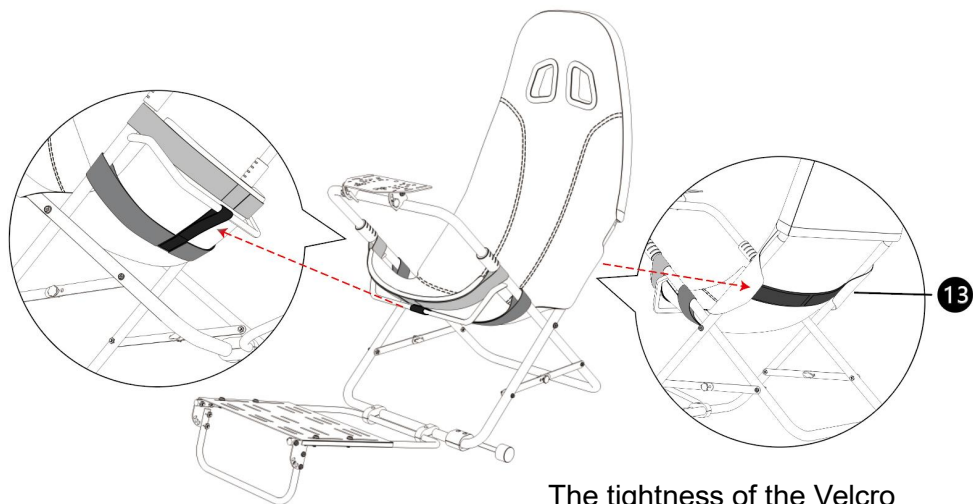

The tightness of the Velcro strap can be adjusted at will

Complete assembly



Manufacturer: Shanghaimuxinmuyeyouxiangongsi

Address: Shuangchenglu 803nong11hao1602A-1609shi, baoshanqu, shanghai 200000 CN.

Imported to AUS: SIHAO PTY LTD. 1 ROKEVA STREETEASTWOOD NSW 2122 Australia

Imported to USA: Sanven Technology Ltd. Suite 250, 9166 Anaheim Place, Rancho Cucamonga, CA 91730

UK	REP
-----------	------------

YH CONSULTING LIMITED. C/O YH Consulting Limited Office 147, Centurion House, London Road, Staines-upon-Thames, Surrey, TW18 4AX

EC	REP
-----------	------------

E-CrossStu GmbH
Mainzer Landstr.69,
60329 Frankfurt am Main.



VEVOR

Affordable. Reliable. Home Improvement.

SUPPORT DE VOLANT

MODÈLE : 6001

VEVOR

Affordable. Reliable. Home Improvement.

STEERING WHEEL STAND

Modèle : 6001



Ceci est le mode d'emploi d'origine. Veuillez lire attentivement l'intégralité du manuel avant utilisation. VEVOR se réserve le droit d'interpréter clairement ce manuel d'utilisation. L'apparence du produit dépend du produit que vous avez reçu. Veuillez nous excuser pour les éventuelles mises à jour technologiques ou logicielles.







Avertissement - Pour réduire le risque de blessure, l'utilisateur doit lire attentivement le manuel d'instructions.



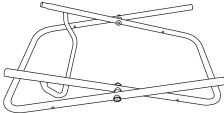
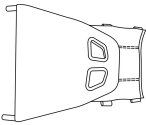
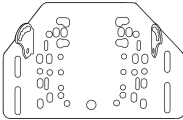

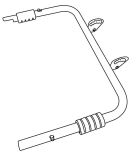
Attention

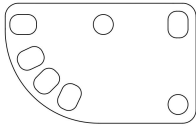
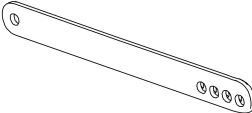
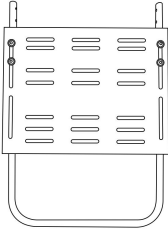
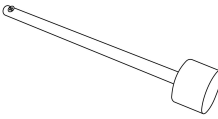



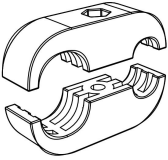

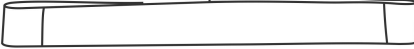
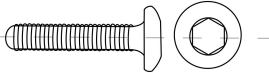
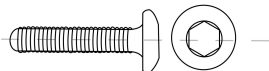
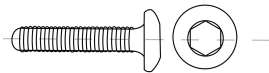
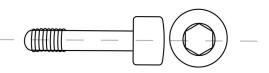
- Veuillez installer et utiliser le support conformément aux instructions .
- Veuillez installer modérément, évitez les fortes vibrations .
- Ne pas conserver dans des conditions humides, à des températures élevées ou dans un endroit poussiéreux .
- La structure du produit est flexible. Portez des gants de travail lors de l'assemblage. Attention aux mains blessées lors de l'installation.
- Les enfants doivent être sous la surveillance d'un adulte lorsqu'ils utilisent le produit.

Conservez le manuel.

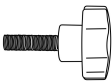
Liste des pièces			
Code	Image	Nom	Qté.
1		Support principal	1
2		Arrière de la tête	1
3		Panneau de volant	1

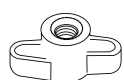
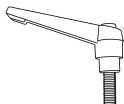
4		pièce en forme de U	1
5		Cadre de pédale divisé 6001 en forme de U	1
6		Ajuster la pièce de connexion pour le cadre de la pédale	2
7		Connecteur de cadre	4
8		Panneau de pédale divisé 6001	1
9		Tige de support anti-renversement	1
10		Attaches en plastique (25/12)	1

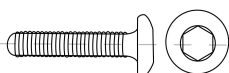
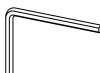
11		Attaches en plastique (25/16)	2
12		Sangle d'arrimage	6
13		Ceinture de soutien lombaire	1
UN		Vis M 8x20	2+1
B		Vis M 6x25	8+1
C		Vis M 6x35	4+1
D		Vis M 6x35	4+1
E		Contre-écrou M6	8+1
F		Écrou à bride M6	8+6

G		Vis de poignée Torx M6×15	2
H		Écrou à oreilles fendu M6	2
je		Écrou à oreilles fendu M8	2
J		Clé en L M8× 16	2
K		Écrou à bride M8	2+1
L		Vis M 6×16	12
M		Clé hexagonale 5 mm	1
N		ouvert Clé 10-13	1

Remarque : 12 vis M6*16 et 6 écrous M6 sont gratuits.

★ Pour la liste des kits de siège et l'installation, veuillez vous référer au manuel de procédure d'installation du siège en pièce jointe.

ÉTAPE 1 :

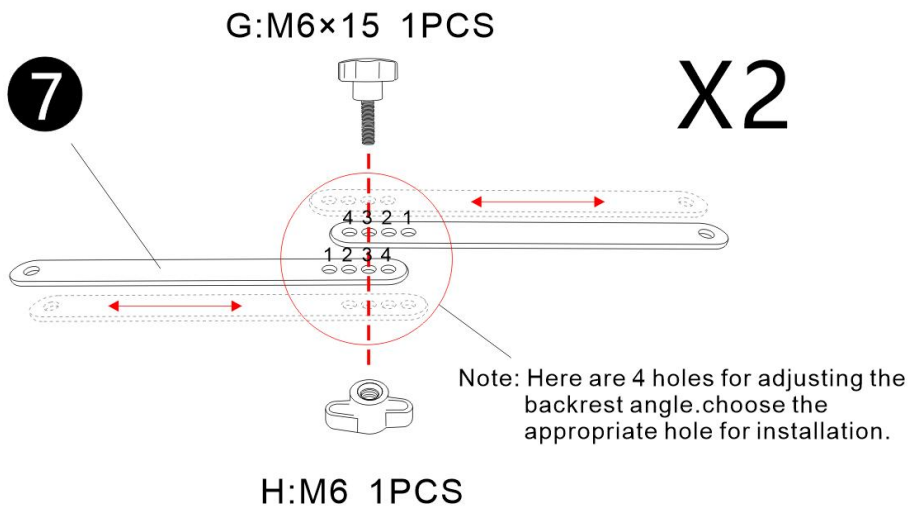

ÉTAPE 2 :

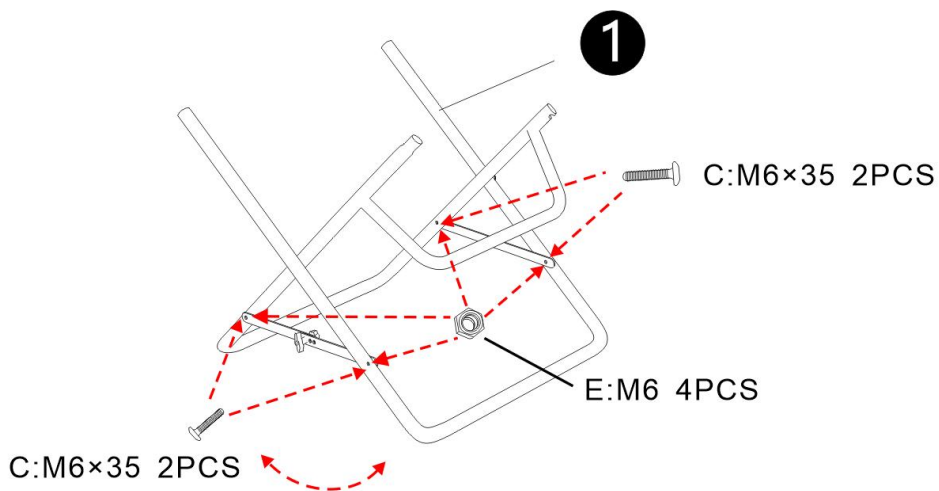

ÉTAPE 3 :

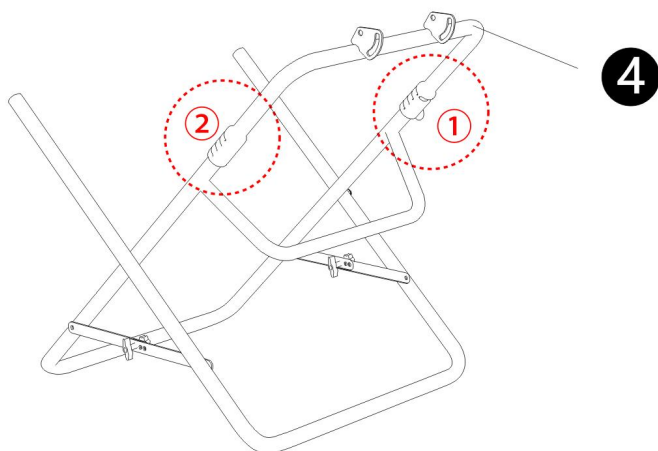

1 Insérez d'abord 4 dans le côté gauche du tube du cadre.



étape 1 : appuyez sur le bouton à ressort sur le côté long du 4, insérez le côté long du 4 dans le cadre 1, lorsque vous entendez un son de « clic », la bille glisse dans la fente du cadre principal .

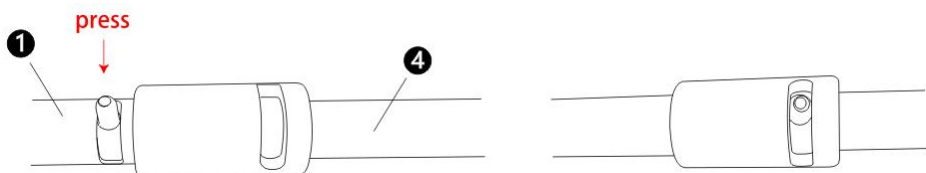

étape 2 : appuyez à nouveau sur le ressort du bouton, faites glisser le tube de boucle latéral long vers le principal cadre, en entendant un son de « clic », la bille glisse dans la fente du tube de boucle .

2. Fixez ensuite 4 de l' autre côté du tube du cadre.

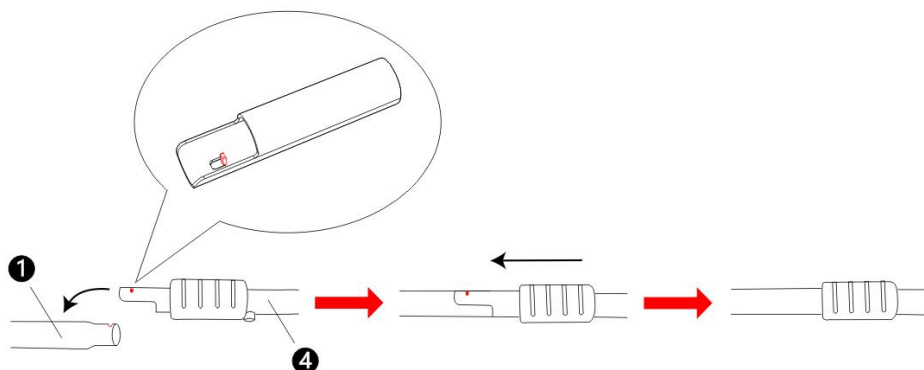

étape 3 : Placez la bosse du côté court 4 dans la fente du cadre principal et faites glisser le tube de boucle de l'extrémité courte dans le cadre principal

ÉTAPE 4 :

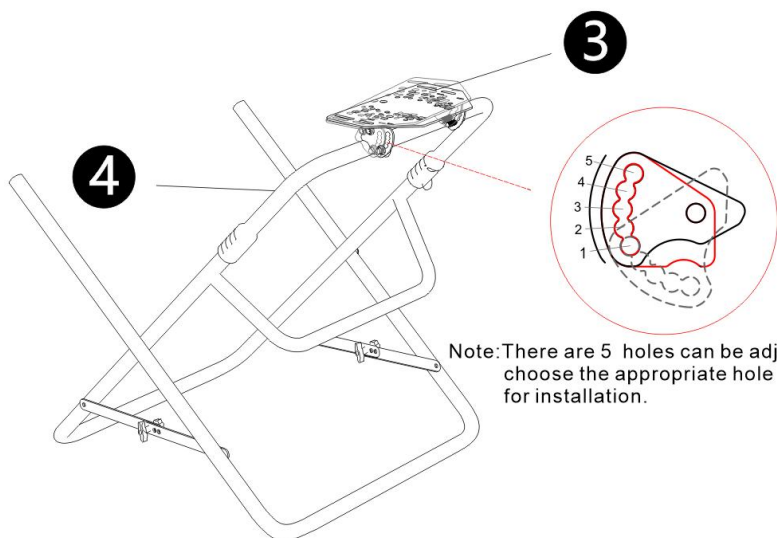

Note: There are 5 holes can be adjusted. choose the appropriate hole for installation.

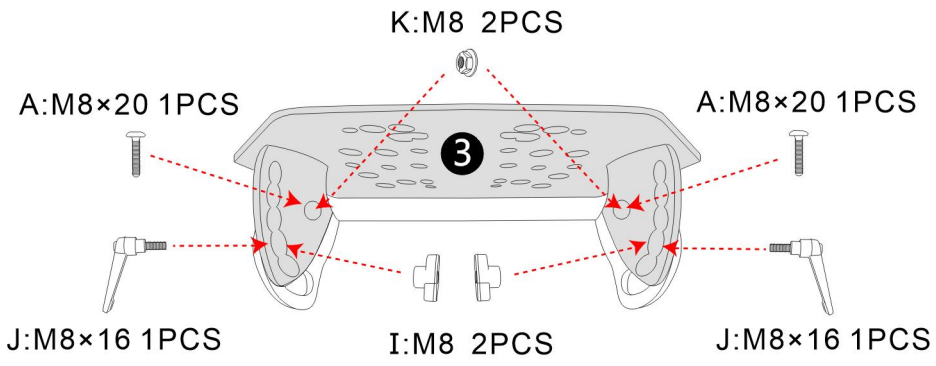

ÉTAPE 5 :

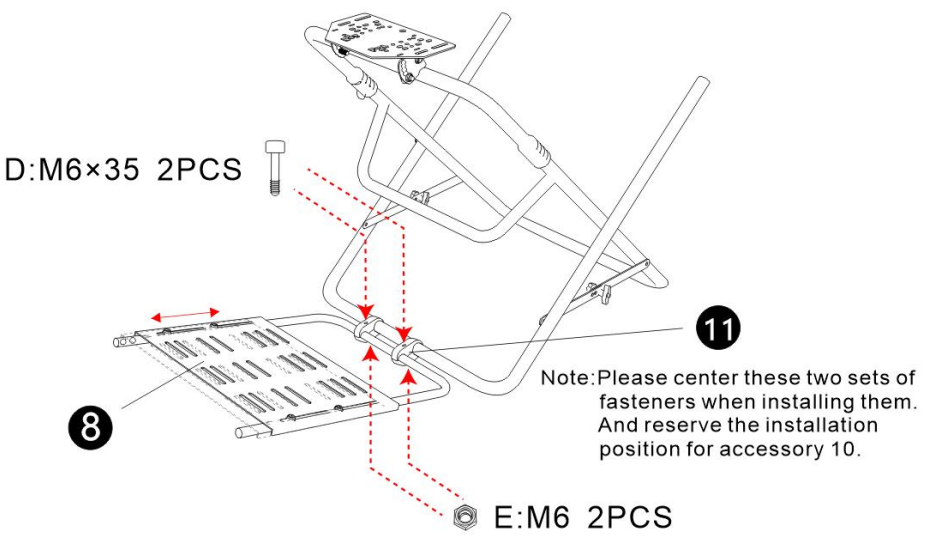

ÉTAPE 6 :

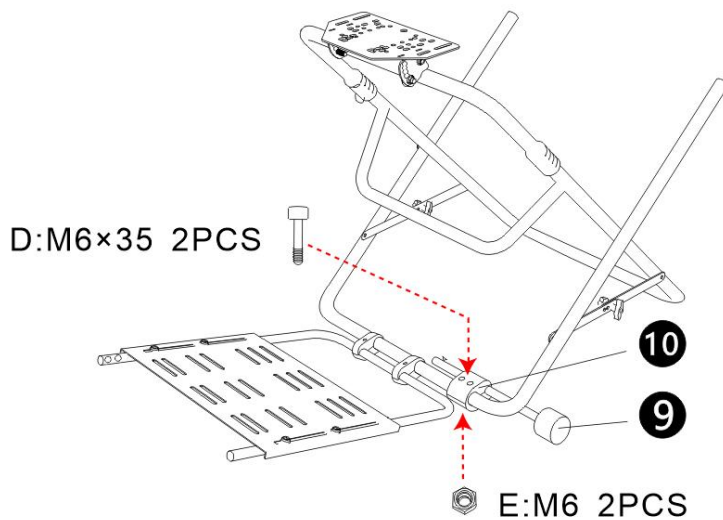

ÉTAPE 7 :

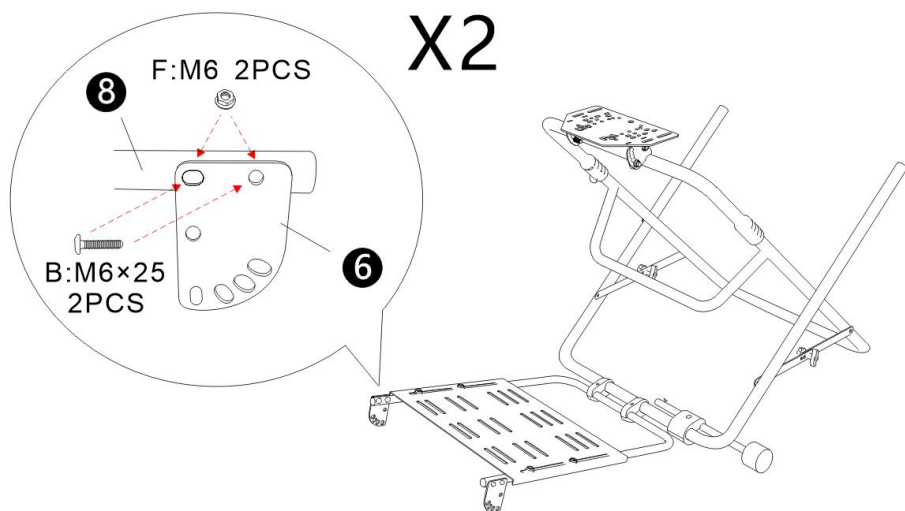

ÉTAPE 8 :

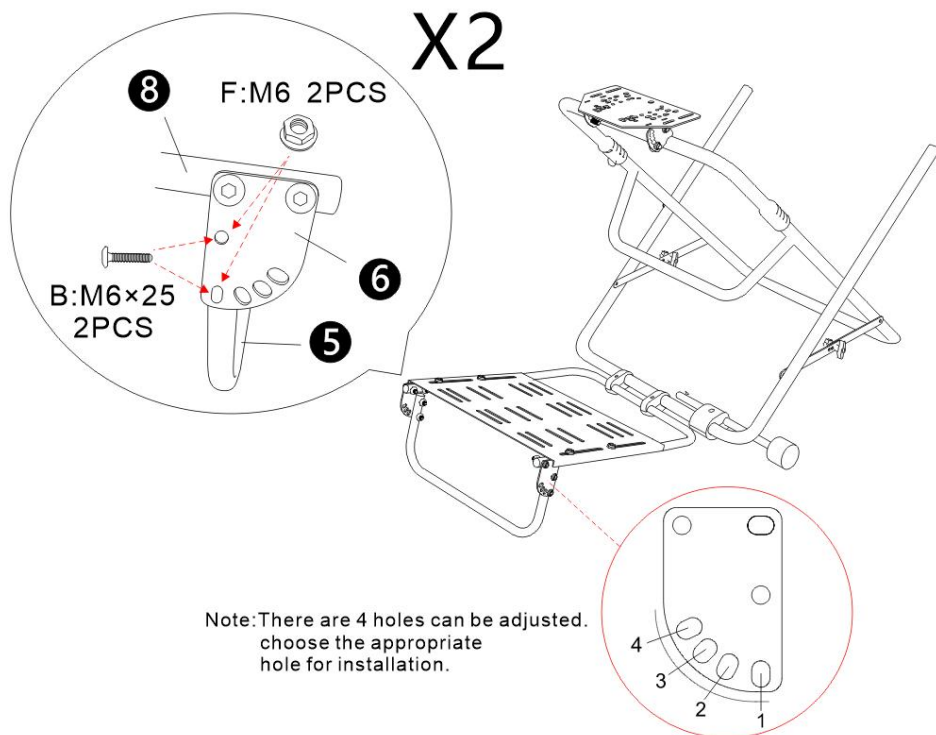

ÉTAPE 9 :

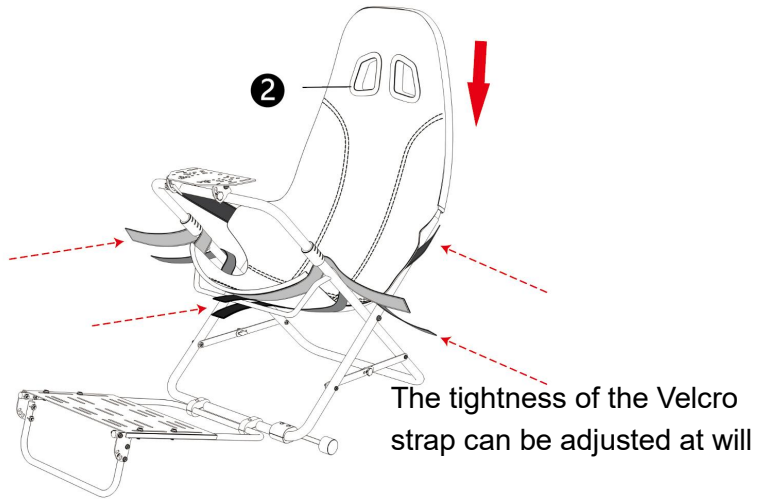

ÉTAPE 10 :

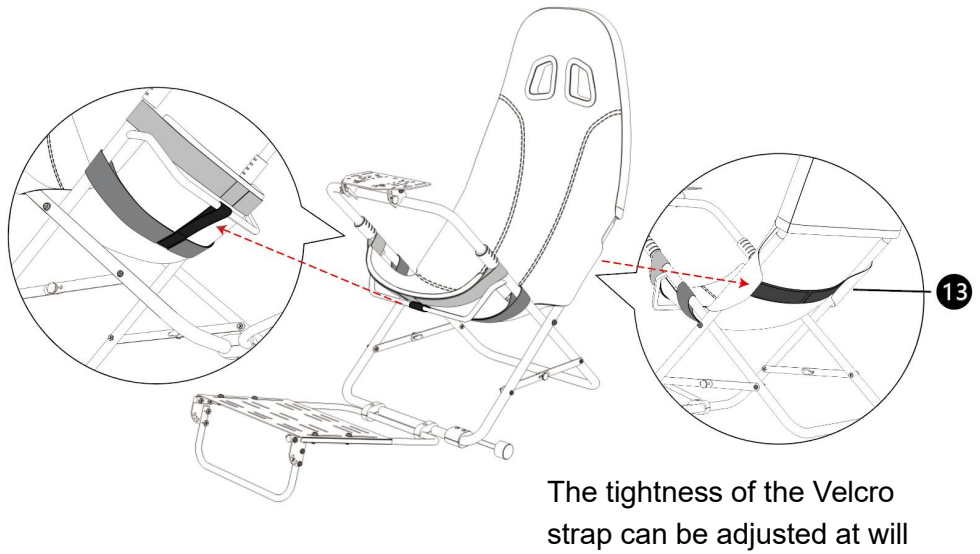

Assemblage complet



Fabricant : Shanghaimuxinmuyeyouxiangongsi

Adresse : Shuangchenglu 803nong11hao1602A-1609shi, baoshanqu, Shanghai 200 000 CN.

Importé en Australie : SIHAO PTY LTD. 1 ROKEVA STREET, ASTWOOD NSW 2122 Australie

Importé aux États-Unis : Sanven Technology Ltd. Suite 250, 9166 Anaheim

Lieu, Rancho Cucamonga, CA 91730

UK	REP
-----------	------------

YH CONSULTING LIMITED. C/O YH Consulting Limited Office 147, Centurion House, London Road, Staines-upon-Thames, Surrey, TW18 4AX

EC	REP
-----------	------------

E-CrossStu GmbH
Mainzer Landstr.69,
60329 Frankfurt am Main.



VEVOR

Affordable. Reliable. Home Improvement.

LENKRADSTÄNDER

MODELL: 6001

VEVOR

Affordable. Reliable. Home Improvement.

STEERING WHEEL STAND

Modell:6001



Dies ist die Originalanleitung. Bitte lesen Sie alle Anweisungen sorgfältig durch, bevor Sie das Gerät in Betrieb nehmen. VEVOR behält sich eine klare Auslegung unserer Bedienungsanleitung vor. Das Aussehen des Produkts hängt vom gelieferten Produkt ab. Bitte haben Sie Verständnis dafür, dass wir Sie nicht erneut über Technologie- oder Software-Updates informieren.





Warnung: Um das Verletzungsrisiko zu verringern, muss der Benutzer die Bedienungsanleitung sorgfältig lesen.



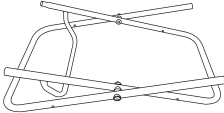
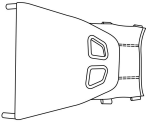

Aufmerksamkeiten

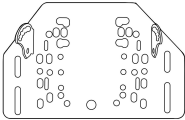
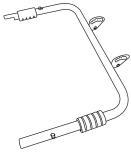
- Bitte installieren und verwenden Sie den Ständer gemäß der Anleitung .
- Bitte maßvoll installieren, starke Vibrationen vermeiden .
- Nicht in feuchter Umgebung, bei hohen Temperaturen oder an einem staubigen Ort aufbewahren .
- Die Produktstruktur ist flexibel. Tragen Sie bei der Montage Arbeitshandschuhe. Achten Sie bei der Installation darauf, dass Ihre Hände nicht verletzen.
- Kinder sollten bei der Verwendung des Produkts unter Aufsicht von Erwachsenen stehen.

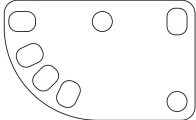
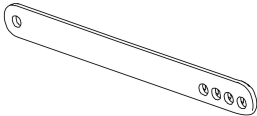
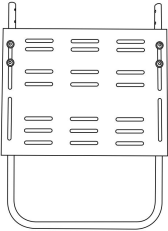
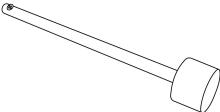
Bewahren Sie das Handbuch auf.

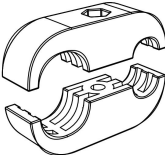
Teilleiste			
Code	Bild	Name	MEN GE.
1		Haupthalterung	1
2		Hinterkopf	1

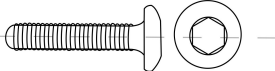
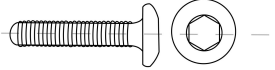
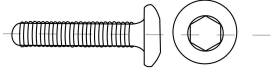
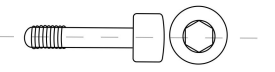
3		Lenkradverkleidung	1
4		U-förmiges Teil	1
5		6001 geteilter Pedalrahmen – U-förmig	1
6		Verbindungsteil für Pedalrahmen anpassen	2
7		Rahmenverbinder	4
8		6001geteiltes Pedalpanel	1
9		Kippsichere Stützstange	1

10		Kunststoffverschlüsse (25/12)	1
11		Kunststoffverschlüsse (25/16)	2
12		Zurrurt	6
13		Lordosenstützgürtel	1
A		Schraube M 8×20	2+1
B		Schraube M 6×25	8+1
C		Schraube M 6×35	4+1
D		Schraube M 6×35	4+1
E		Kontermutter M6	8+1

F		Flanschmutter M6	8+6
G		Torx-Griffschraube M6x15	2
H		Schlitz-Rändelmutter r M6	2
ICH		Schlitz-Rändelmutter r M8	2
J		L-förmiger Schraubenschlüssel M8x 16	2
K		Flanschmutter M8	2+1
L		Schraube M 6x16	12
M		Sechskantschlüssel 5mm	1
N		offenes Ende Schraubenschlüssel 10-13	1

Hinweis: 12 Schrauben M6*16 und 6 Muttern M6 sind im Lieferumfang enthalten.

★ Eine Liste der Sitzbausätze und der Installation finden Sie im Anhang des Handbuchs zur Sitzinstallation.

SCHRITT 1 :

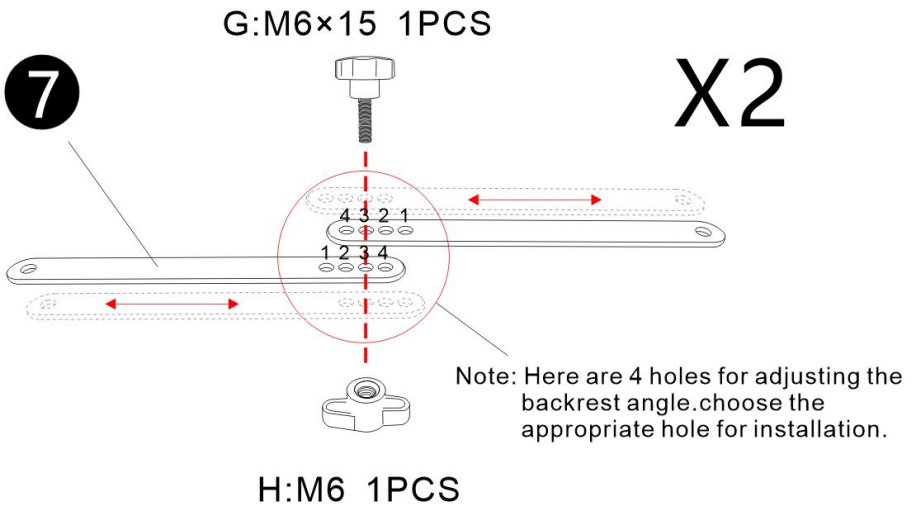

SCHRITT 2:

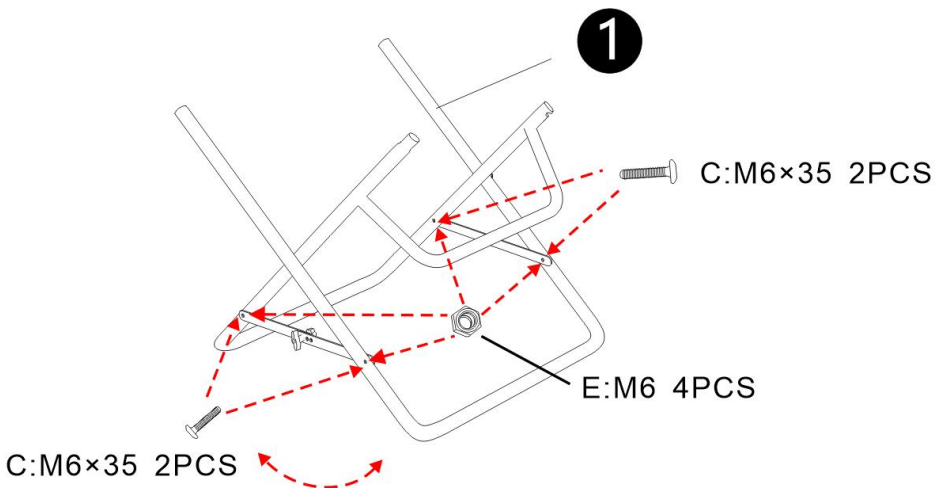

SCHRITT 3:

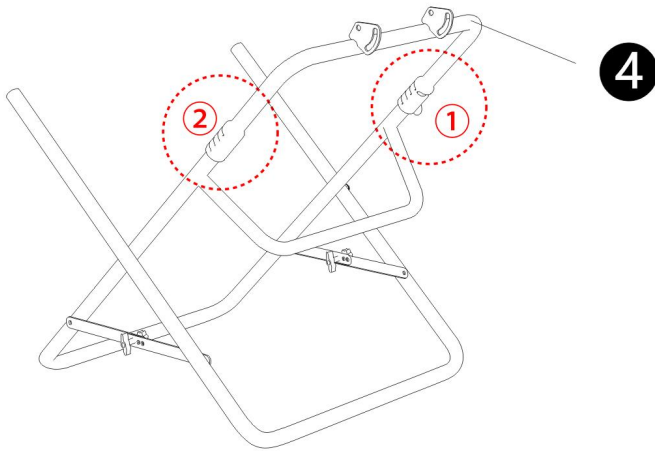

① Zuerst 4 in die linke Seite des Rahmenrohrs einführen.



Schritt 1 : Drücken Sie die Knopffeder an der langen Seite von 4, stecken Sie die lange Seite von 4 in die Rahmen 1: Wenn Sie ein „Klick

“-Geräusch hören, gleitet die Murmel in den Schlitz des Hauptrahmens .

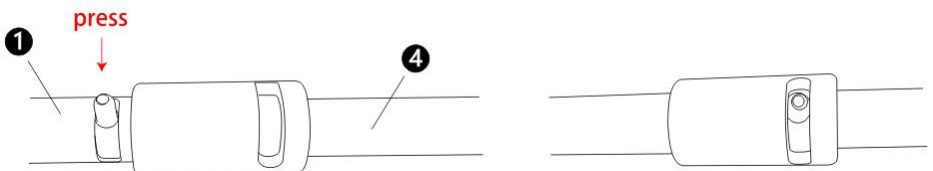

Schritt 2 : Drücken Sie die Knopffeder erneut und schieben Sie das lange Schnallenrohr zum Hauptteil Rahmen. Wenn Sie ein „Klick“-Geräusch hören, gleitet die Murmel in den Schlitz des Schnallenrohrs .

② **Befestigen Sie dann 4 an der anderen Seite des Rahmenrohrs.**

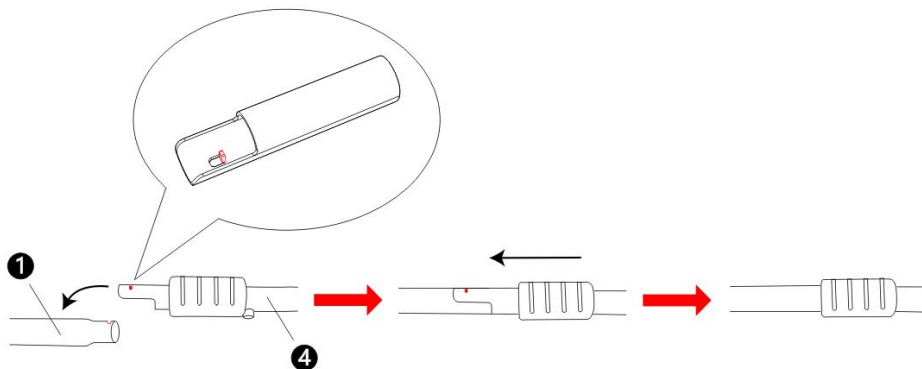

Schritt 3 : Setzen Sie die Erhebung der kurzen Seite 4 in den Schlitz des Hauptrahmens ein und schieben Sie das Schnallenrohr des kurzen Endes in den Hauptrahmen

SCHRITT 4:

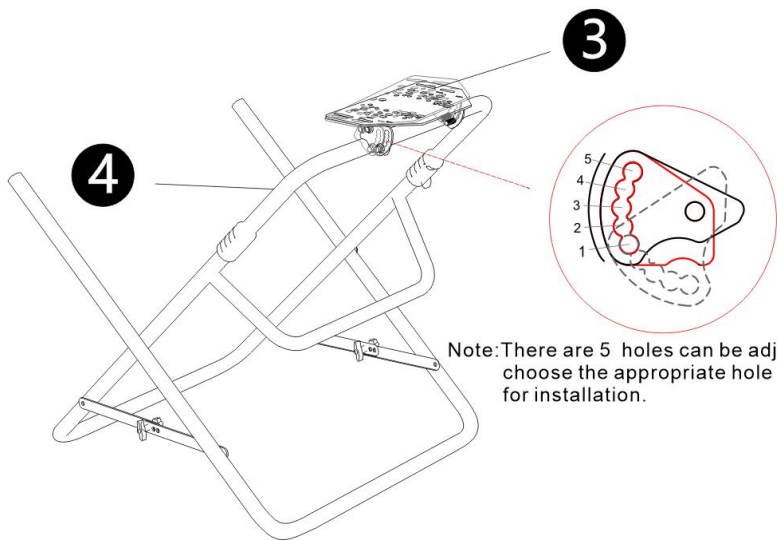

Note: There are 5 holes can be adjusted. choose the appropriate hole for installation.

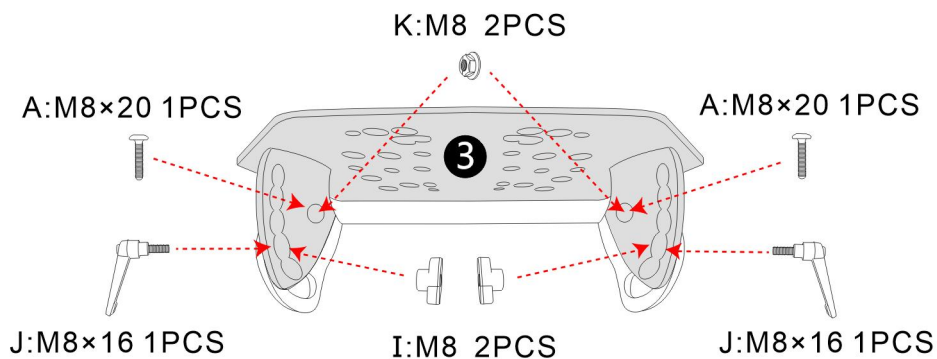

SCHRITT 5:

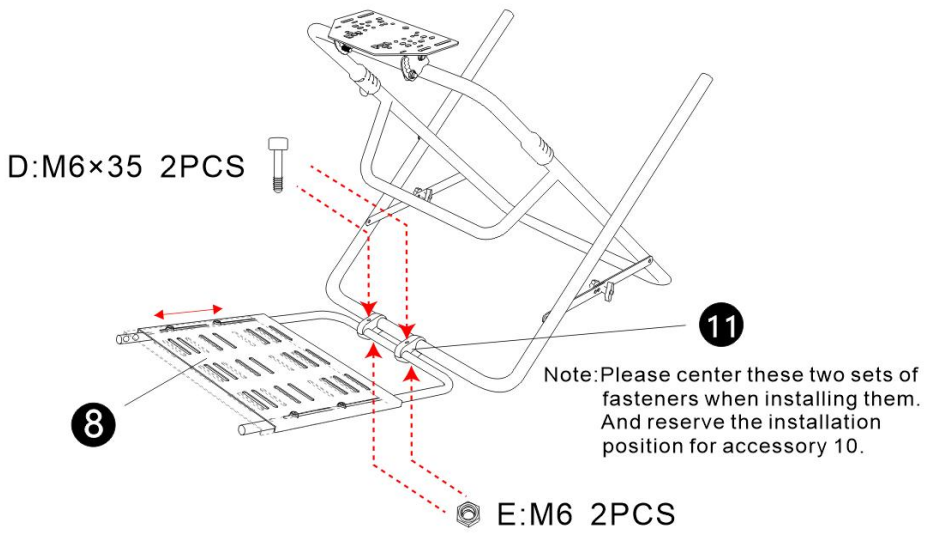

SCHRITT 6:

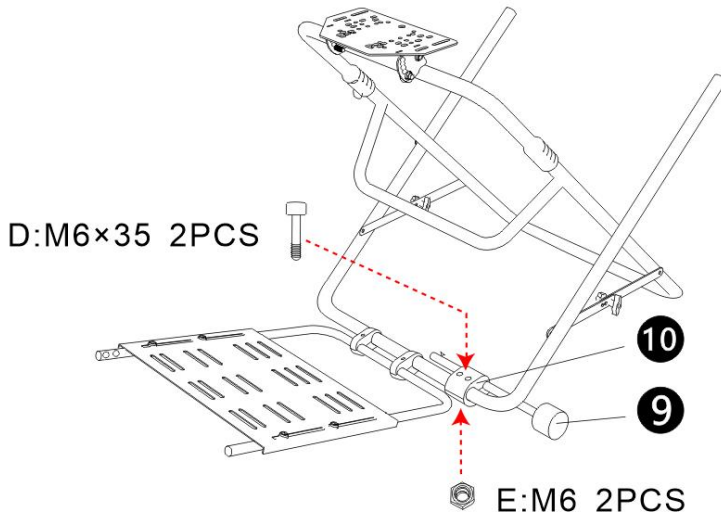

SCHRITT 7:

X2

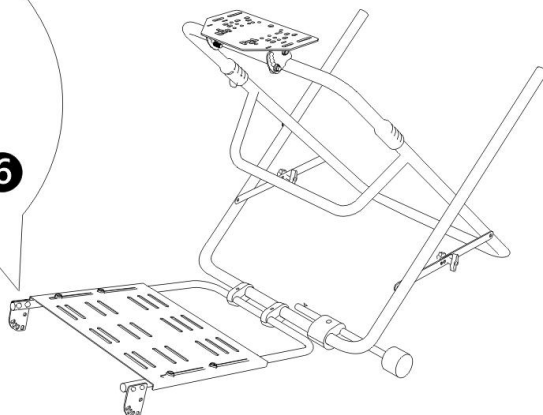
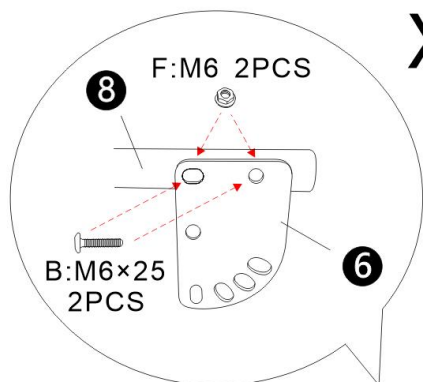

SCHRITT 8:

X2

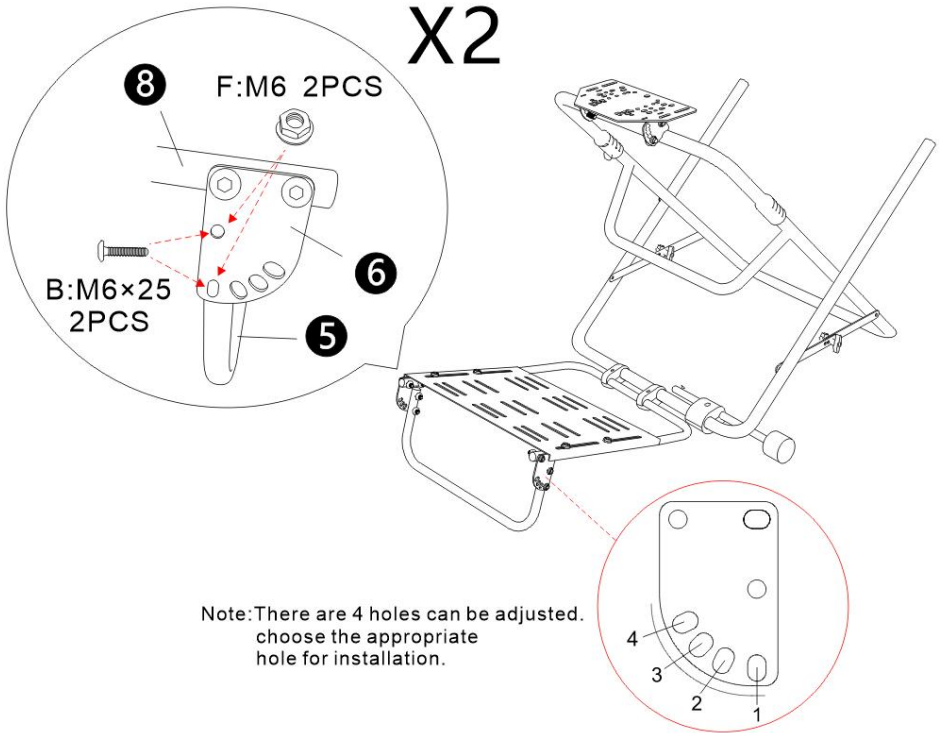

SCHRITT 9:

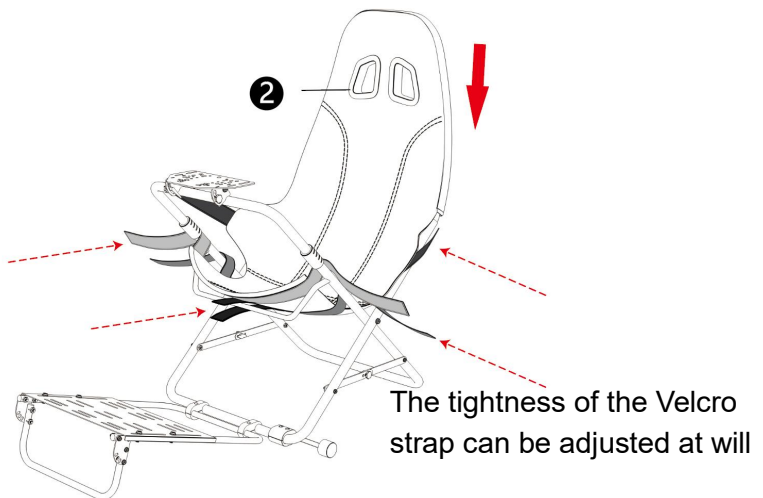

SCHRITT 10:

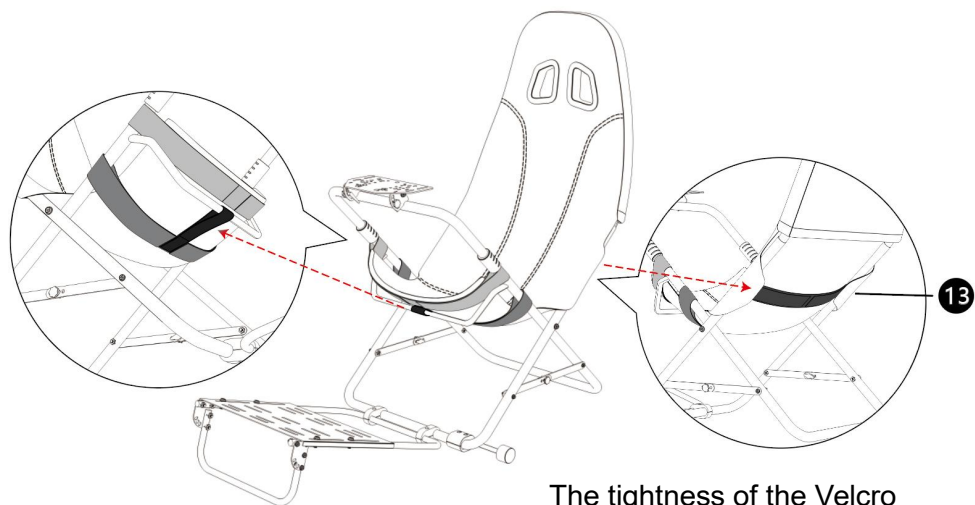

The tightness of the Velcro strap can be adjusted at will

Komplettmontage



Hersteller: Shanghaimuxinmuyeyouxiangongsi

Adresse: Shuangchenglu 803nong11hao1602A-1609shi, baoshanqu, Shanghai 200000 CN.

Importiert nach AUS: SIHAO PTY LTD. 1 ROKEVA STREETEASTWOOD NSW 2122 Australien

Importiert in die USA: Sanven Technology Ltd. Suite 250, 9166 Anaheim Place, Rancho Cucamonga, CA 91730

UK	REP
-----------	------------

YH CONSULTING LIMITED. C/O YH Consulting Limited Office 147, Centurion House, London Road, Staines-upon-Thames, Surrey, TW18 4AX

EC	REP
-----------	------------

E-CrossStu GmbH
Mainzer Landstr.69,
60329 Frankfurt am Main.



VEVOR

Affordable. Reliable. Home Improvement.

SUPPORTO PER VOLANTE

MODELLO: 6001

VEVOR

Affordable. Reliable. Home Improvement.

STEERING WHEEL STAND

Modello:6001



Queste sono le istruzioni originali, si prega di leggere attentamente tutte le istruzioni del manuale prima dell'uso. VEVOR si riserva la piena interpretazione del proprio manuale utente. L'aspetto del prodotto dipenderà dal prodotto ricevuto. Vi preghiamo di scusarci se non vi informeremo più in caso di aggiornamenti tecnologici o software sul nostro prodotto.





Avvertenza: per ridurre il rischio di lesioni, l'utente deve leggere attentamente il manuale di istruzioni.



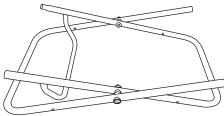
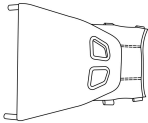

Attenzioni

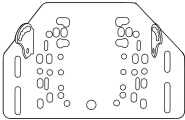
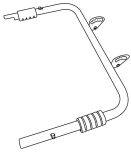

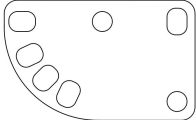
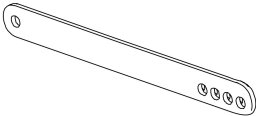
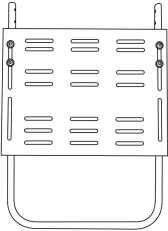
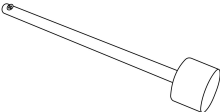

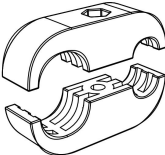
- Installare e utilizzare il supporto seguendo le istruzioni .
- Si prega di installare con moderazione, evitando forti vibrazioni .
- Non conservare in condizioni di umidità, temperature elevate o luoghi polverosi .
- La struttura del prodotto è flessibile, indossare guanti da lavoro durante il montaggio. Fare attenzione a non farsi male alle mani durante l'installazione.
- I bambini devono utilizzare il prodotto sotto la supervisione di un adulto.

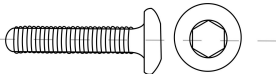
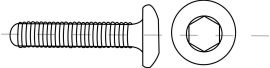
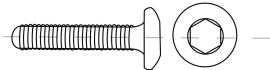
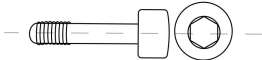
Salva il manuale.

Elenco delle parti			
Codice	Immagine	Nome	QUANTITÀ
1		Staffa principale	1
2		Parte posteriore della testa	1

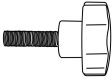
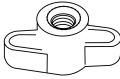
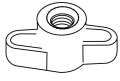
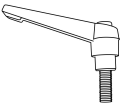
3		Pannello del volante	1
4		Parte a forma di U	1
5		Telaio del pedale diviso 6001-a forma di U	1
6		Regolare la parte di collegamento per il telaio del pedale	2
7		Connettore del telaio	4
8		6001 pannello pedali diviso	1
9		Asta di supporto antiribaltamento	1

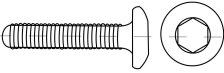
10		Elementi di fissaggio in plastica (25/12)	1
11		Elementi di fissaggio in plastica (25/16)	2
12		Cinghia di ancoraggio	6
13		Cintura di supporto lombare	1
UN		Vite M 8×20	2+1
B		Vite M 6×25	8+1
C		Vite M 6×35	4+1
D		Vite M 6×35	4+1
E		Controdado M6	8+1

F		Dado flangiato M6	8+6
G		Vite con impugnatura Torx M6x15	2
H		Dado a testa zigrinata M6	2
IO		Dado a testa zigrinata M8	2
J		Chiave a L M8x 16	2
K		Dado flangiato M8	2+1
L		Vite M 6x16	12
M		Chiave esagonale da 5 mm	1
N		aperto Chiave inglese 10-13	1

Nota: 12 viti M6*16 e 6 dadi M6 sono gratuiti.

★ Per l'elenco dei kit di sedili e l'installazione, fare riferimento al manuale

di istruzioni per l'installazione dei sedili allegato.

PASSO 1 :

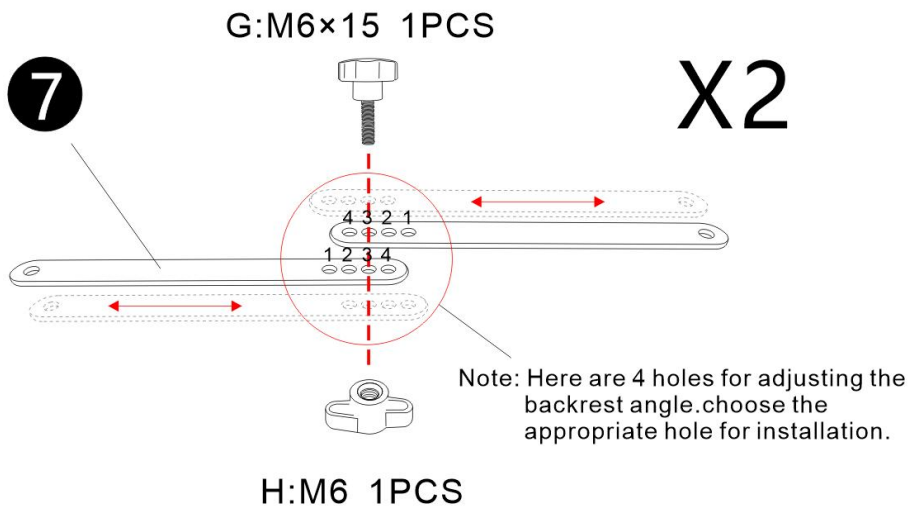

PASSO 2:

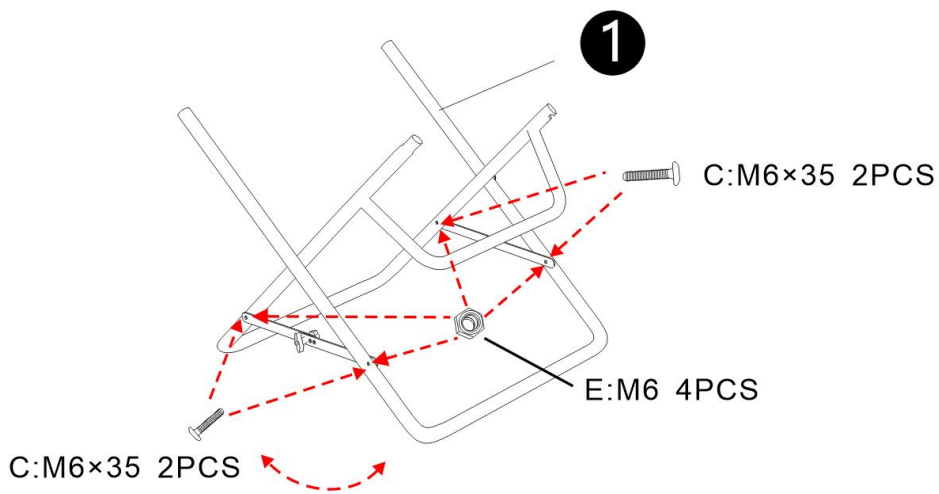

PASSO 3:

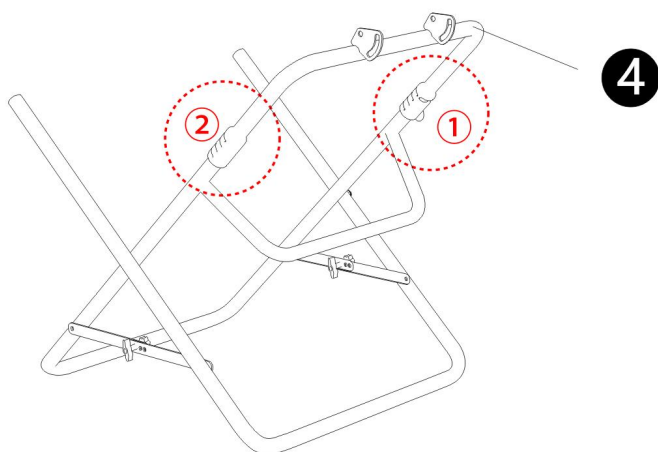

① Inserire prima 4 nel lato sinistro del tubo del telaio.



passo 1 : premere la molla del pulsante sul lato lungo del 4, inserire il lato lungo del 4 nel fotogramma 1, quando si sente un "clic", la biglia scivola nella fessura del telaio principale .

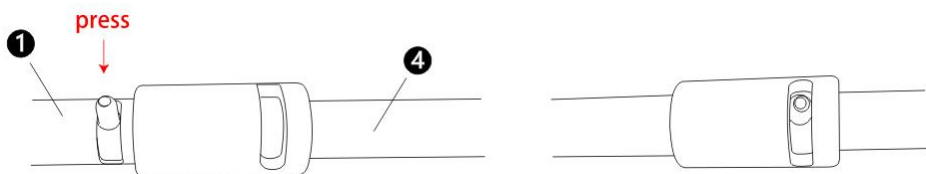

passo 2 : premere nuovamente la molla del pulsante, far scorrere il tubo della fibbia laterale lungo verso la parte principale telaio, quando si sente

un "clic", la biglia scivola nella fessura del tubo della fibbia .

② Quindi fissare 4 all'altro lato del tubo del telaio.

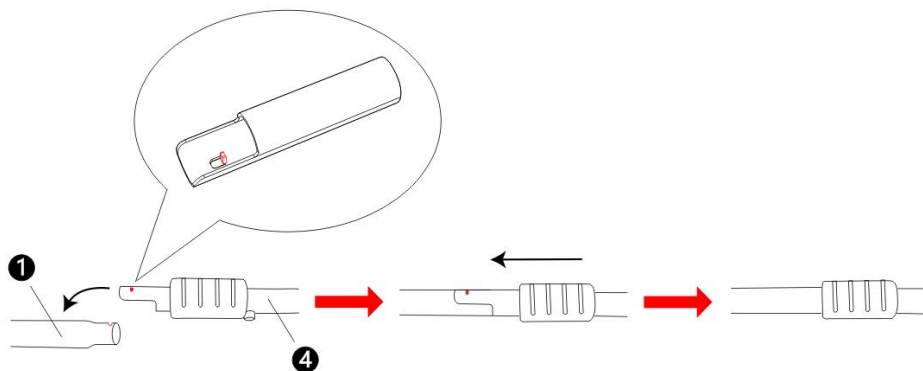

passo 3 : Inserire la protuberanza del lato corto 4 nella fessura del telaio principale e farla scorrere il tubo della fibbia dell'estremità corta nel telaio principale

PASSO 4:

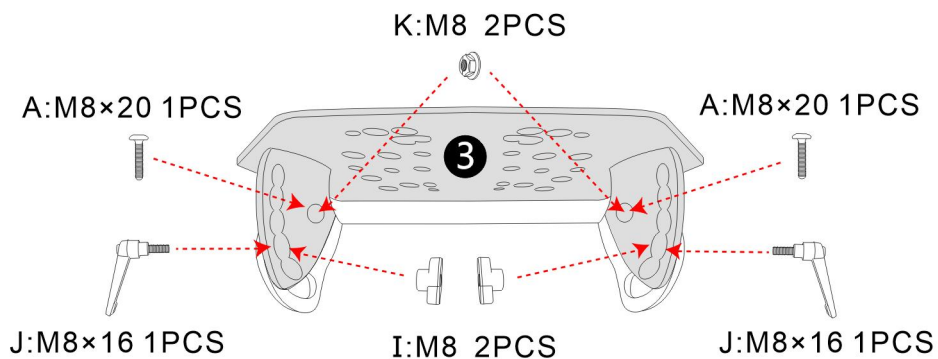
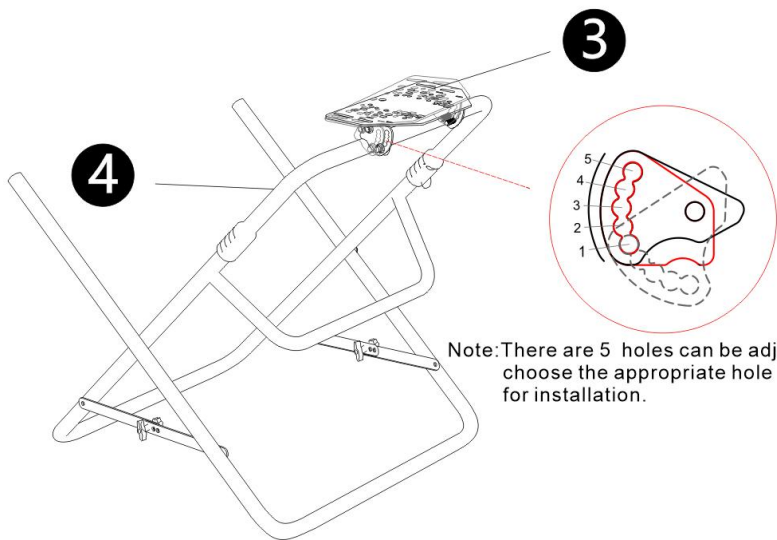

PASSO 5:

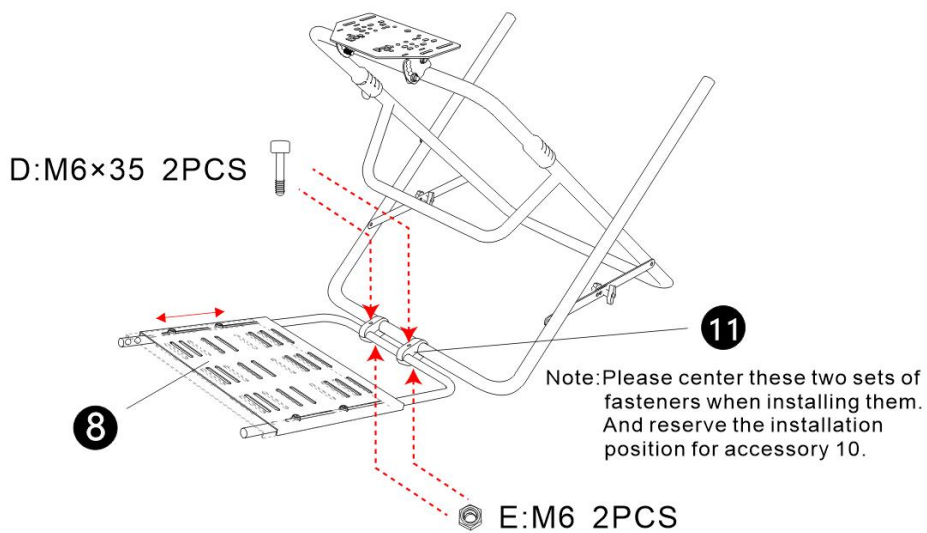

PASSO 6:

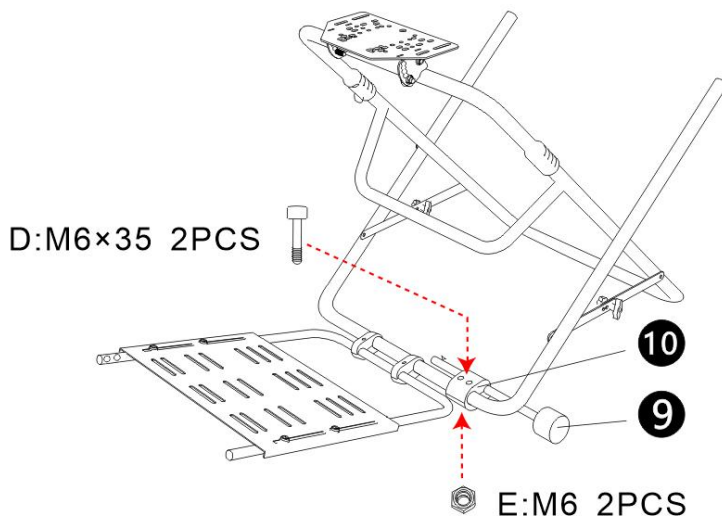

PASSO 7:

X2

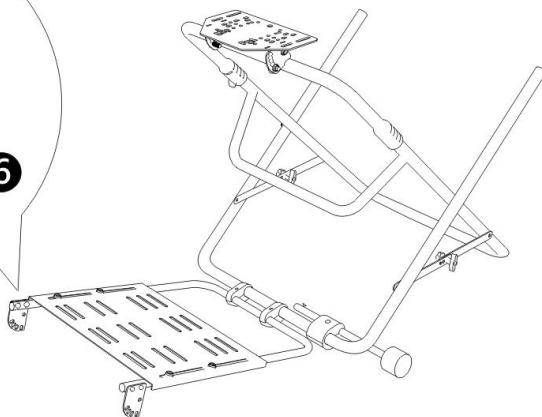
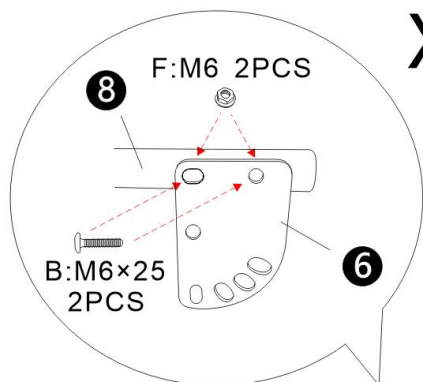

PASSO 8:

X2

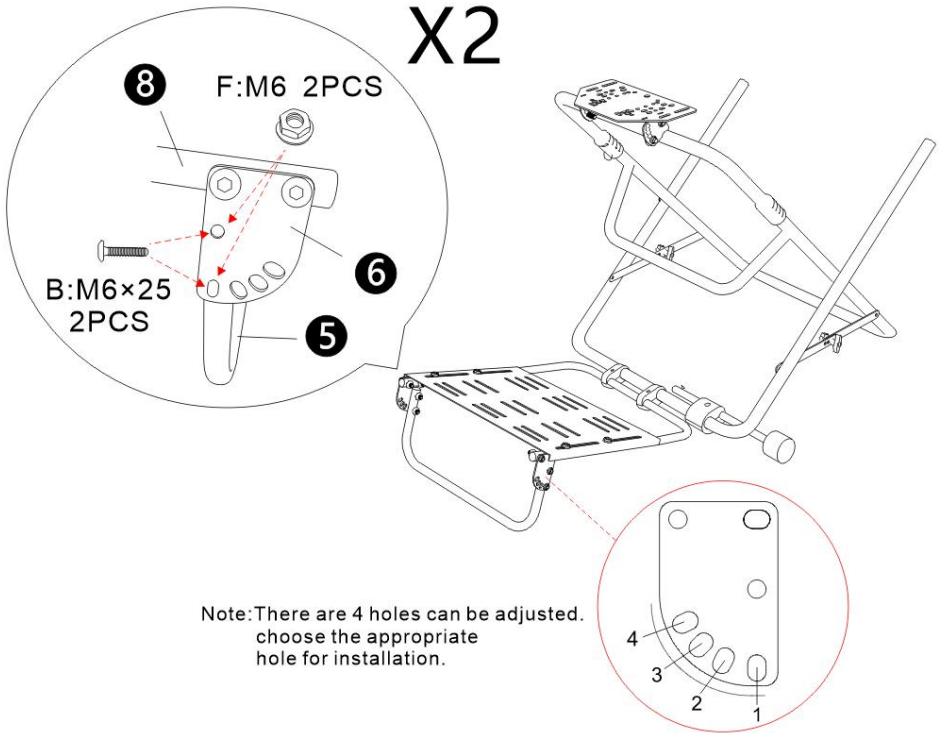

PASSO 9:

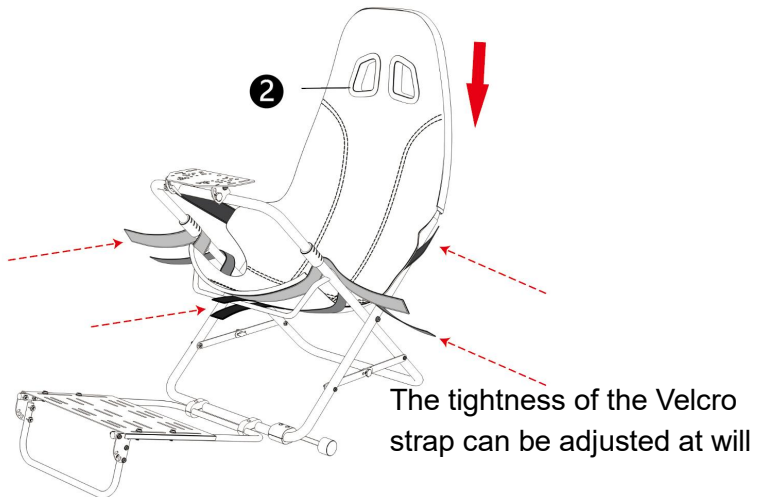

PASSO 10:

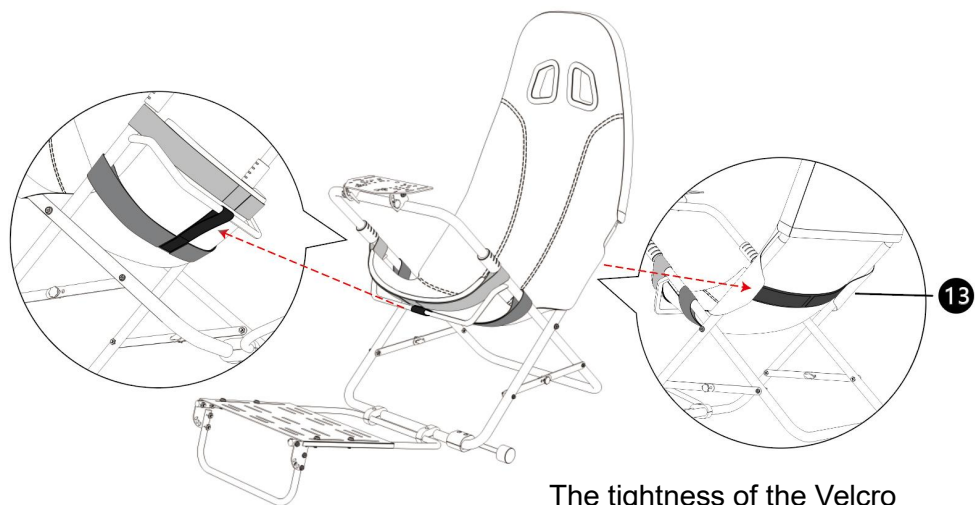

The tightness of the Velcro strap can be adjusted at will

Montaggio completo



Produttore: Shanghaimuxinmuyeyouxiangongsi

Indirizzo: Shuangchenglu 803nong11hao1602A-1609shi, baoshanqu, Shanghai 200000 CN.

Importato in AUS: SIHAO PTY LTD. 1 ROKEVA STREETEASTWOOD
Nuovo Galles del Sud 2122 Australia

Importato negli USA: Sanven Technology Ltd. Suite 250, 9166 Anaheim
Luogo, Rancho Cucamonga, CA 91730

UK	REP
-----------	------------

YH CONSULTING LIMITED. C/O YH Consulting
Limited Office 147, Centurion House, London
Road, Staines-upon-Thames, Surrey, TW18 4AX

EC	REP
-----------	------------

E-CrossStu GmbH
Mainzer Landstr.69,
60329 Frankfurt am Main.



VEVOR

Affordable. Reliable. Home Improvement.

SOPORTE PARA VOLANTE

MODELO: 6001

VEVOR

Affordable. Reliable. Home Improvement.

STEERING WHEEL STAND

Modelo: 6001



Estas son las instrucciones originales; lea atentamente todas las instrucciones del manual antes de utilizarlo. VEVOR se reserva el derecho de interpretar este manual de usuario. La apariencia del producto dependerá del producto que haya recibido. Le rogamos que no le informemos si hay actualizaciones tecnológicas o de software en nuestro producto.





Advertencia: Para reducir el riesgo de lesiones, el usuario debe leer atentamente el manual de instrucciones.



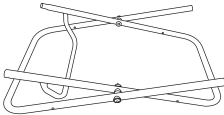
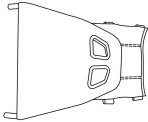

Atenciones

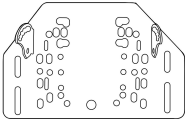
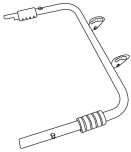
- Instale y utilice el soporte según las instrucciones .
- Por favor, instálolo con moderación, evitando vibraciones fuertes .
- No lo guarde en condiciones de humedad, altas temperaturas o en un lugar polvoriento .
- La estructura del producto es flexible, por lo que se recomienda usar guantes de trabajo durante el montaje. Tenga cuidado con las manos lastimadas al instalarlo.
- Los niños deben estar bajo la supervisión de un adulto cuando utilicen el producto.

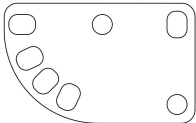
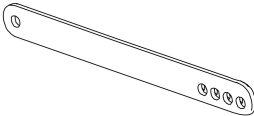
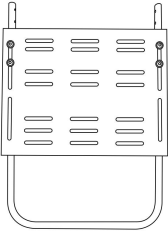
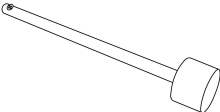
Guarde el manual.

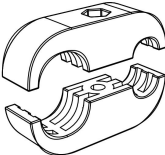
Lista de piezas			
Código	Imagen	Nombre	CANTIDAD.
1		Soporte principal	1
2		Parte posterior de la cabeza	1

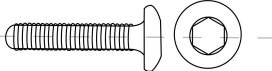
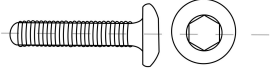
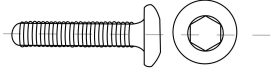
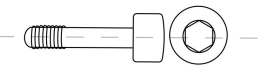
3		Panel del volante	1
4		Pieza en forma de U	1
5		Marco de pedales dividido 6001 en forma de U	1
6		Ajuste de la pieza de conexión para el marco del pedal	2
7		Conector de marco	4
8		Panel de pedales dividido 6001	1
9		Varilla de soporte antivuelco	1

10		Sujetadores de plástico (25/12)	1
11		Sujetadores de plástico (25/16)	2
12		Correa de amarre	6
13		Cinturón de soporte lumbar	1
A		Tornillo M 8x20	2+1
B		Tornillo M 6x25	8+1
do		Tornillo M 6x35	4+1
D		Tornillo M 6x35	4+1
mi		Tuerca de seguridad M6	8+1

F		Tuerca de brida M6	8+6
GRAM O		Tornillo de mango Torx M6×15	2
H		Tuerca de mariposa ranurada M6	2
I		Tuerca de mariposa ranurada M8	2
Yo		Llave en forma de L M8× 16	2
K		Tuerca de brida M8	2+1
Yo		Tornillo M 6×16	12
METR O		Llave hexagonal de 5 mm	1
norte		abierto Llave inglesa 10-13	1

Nota: 12 tornillos M6*16 y 6 tuercas M6 son gratuitos.

★ Para obtener la lista de kits de asientos y su instalación, consulte el

manual de procedimiento de instalación del asiento adjunto.

PASO 1 :

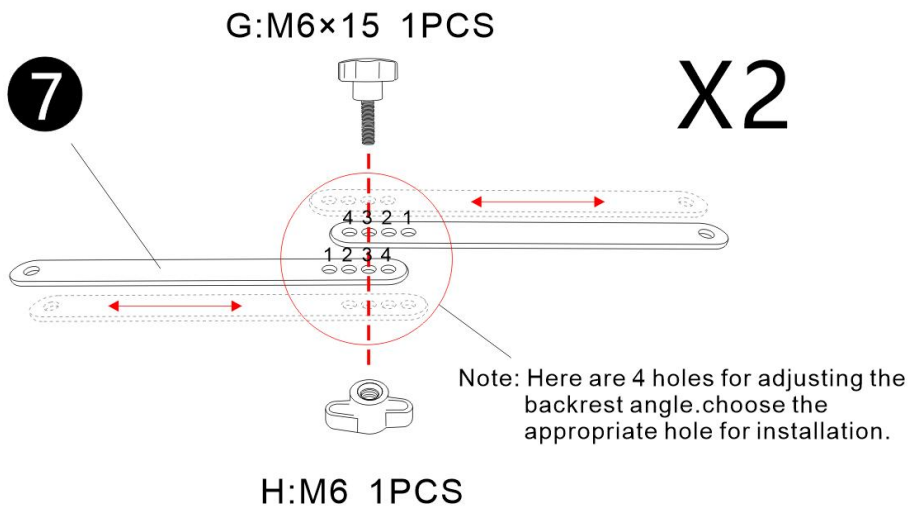

PASO 2:

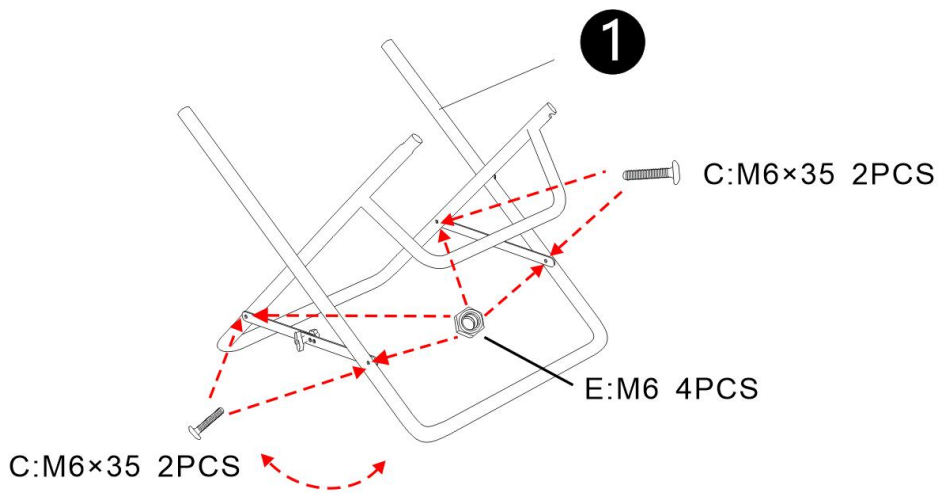

PASO 3:

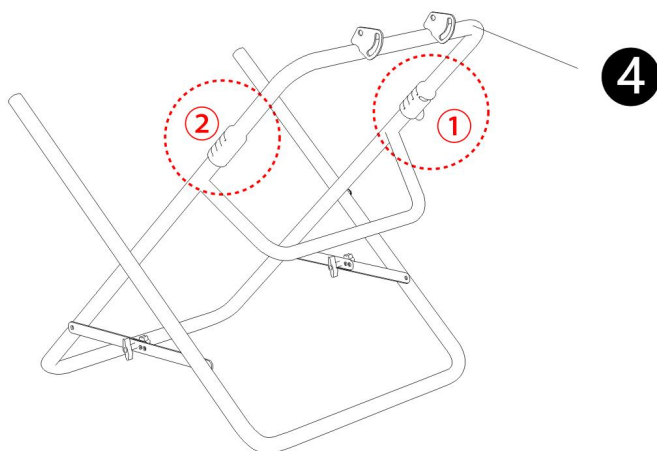

① Primero inserte 4 en el lado izquierdo del tubo del marco.



Paso 1 : Presione el resorte del botón en el lado largo de 4, inserte el lado largo de 4 en el Marco 1, cuando se escucha un sonido de "clic", la canica se desliza hacia la ranura del marco principal .

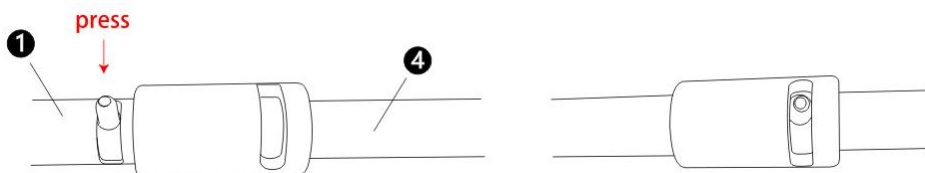

Paso 2 : Presione nuevamente el resorte del botón, deslice el tubo de la hebilla del lado largo hacia el principal Marco, al escuchar un sonido de

"clic", la canica se desliza dentro de la ranura del tubo de la hebilla .

② Luego, fija el 4 al otro lado del tubo del marco.

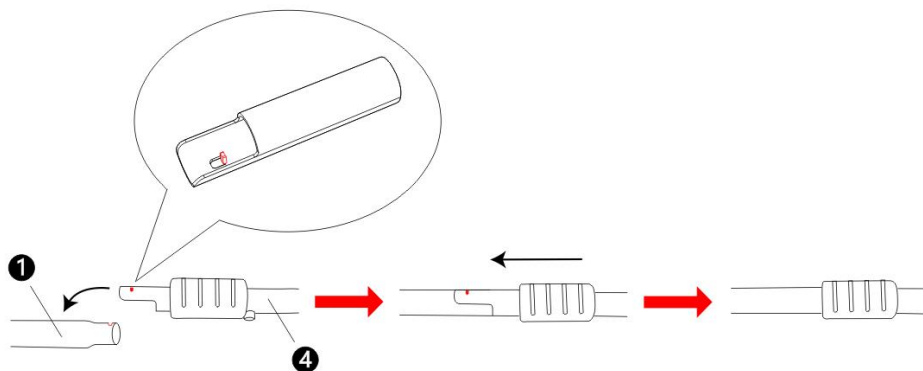

Paso 3 : Coloque la protuberancia del lado corto 4 en la ranura del marco principal y deslícela El tubo de la hebilla del extremo corto en el marco principal

PASO 4:

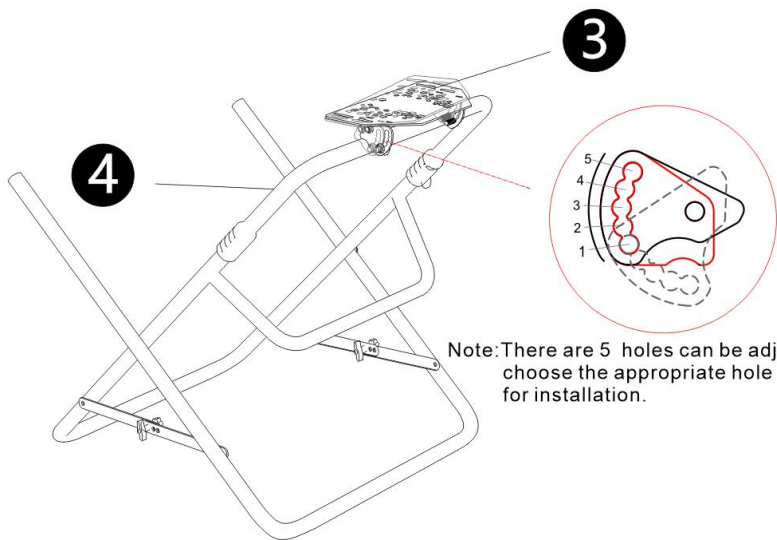

Note: There are 5 holes can be adjusted. choose the appropriate hole for installation.

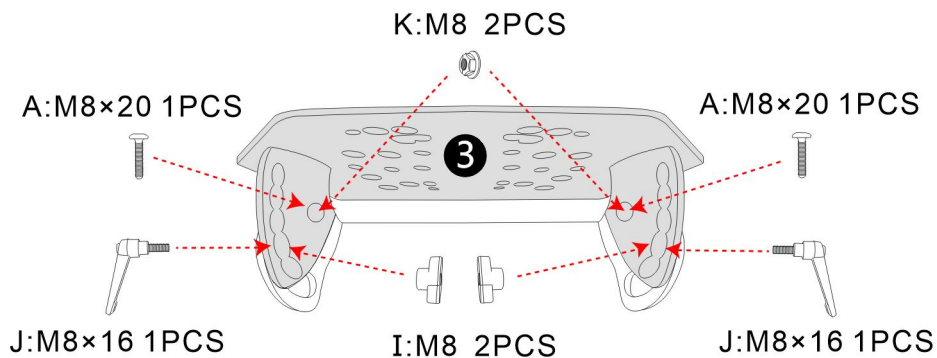

PASO 5:

D:M6×35 2PCS

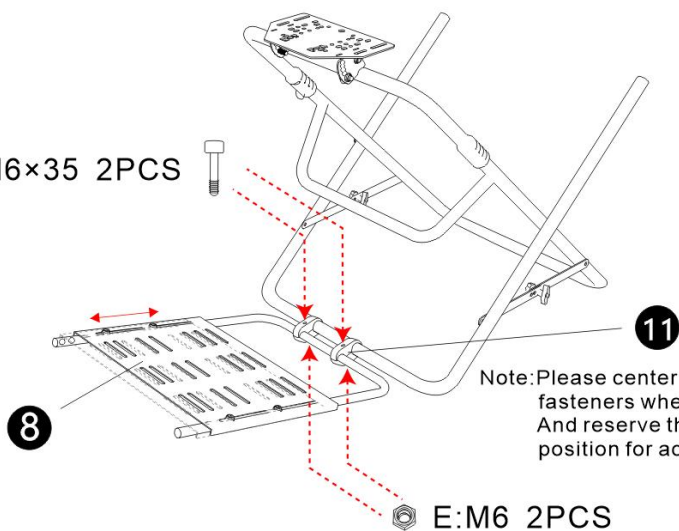

PASO 6:

D:M6×35 2PCS

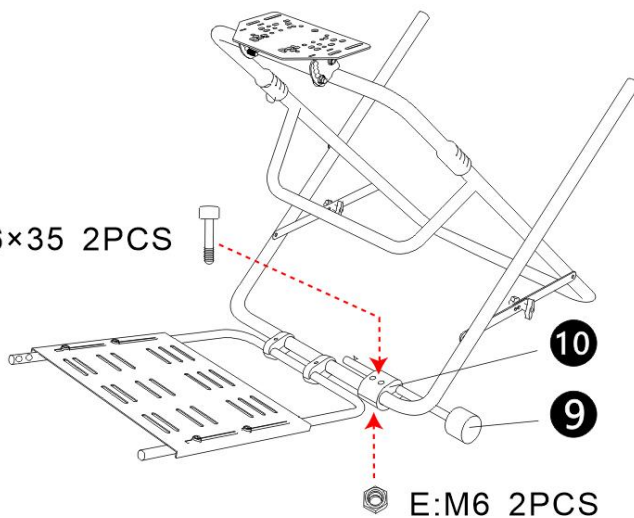

PASO 7:

X2

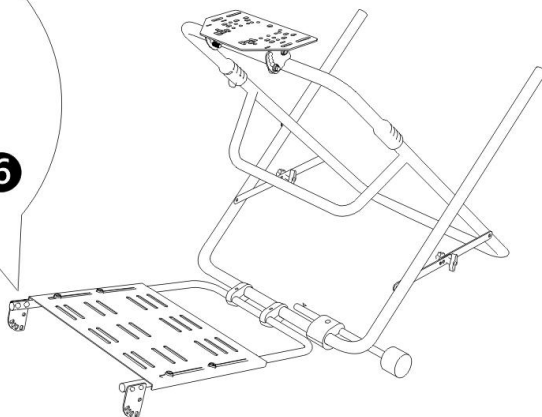
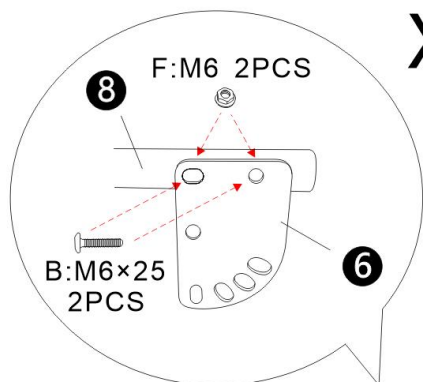

PASO 8:

X2

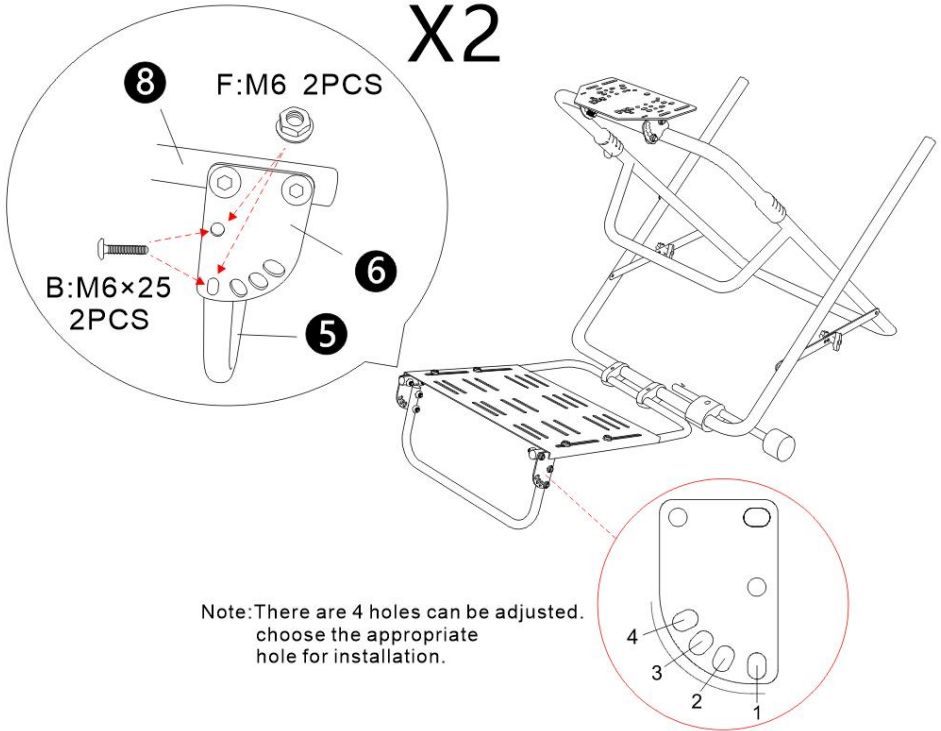

PASO 9:

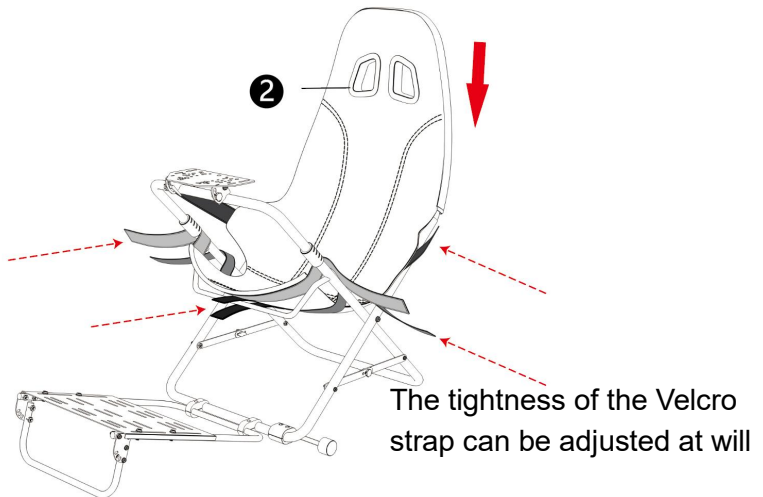

PASO 1 0:

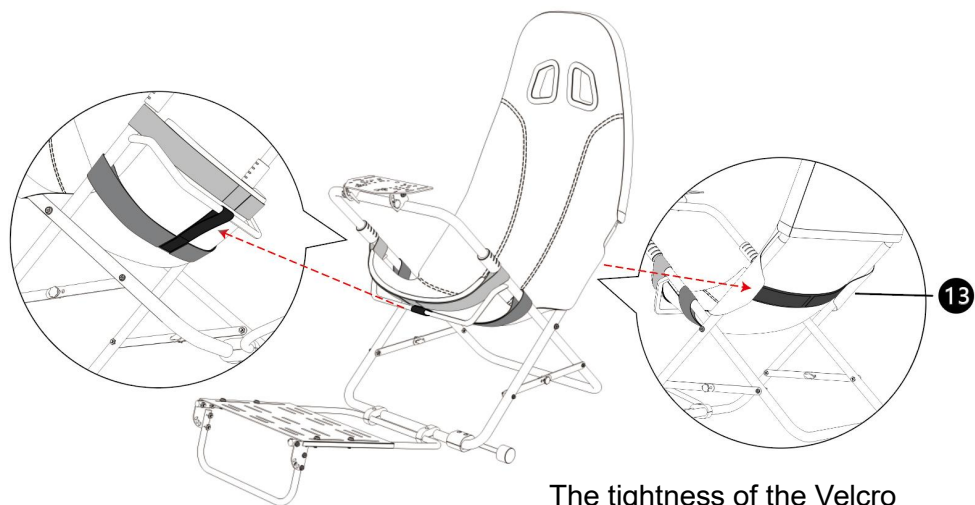

The tightness of the Velcro strap can be adjusted at will

Montaje completo



Fabricante: Shanghaimuxinmuyeyouxiangongsi

Dirección: Shuangchenglu 803nong11hao1602A-1609shi, baoshanqu, Shanghai 200000 CN.

Importado a AUS: SIHAO PTY LTD. 1 ROKEVA STREET, EASTWOOD NSW 2122 Australia

Importado a EE. UU.: Sanven Technology Ltd. Suite 250, 9166 Anaheim Lugar, Rancho Cucamonga, CA 91730

UK	REP
-----------	------------

YH CONSULTING LIMITED. C/O YH Consulting Limited Office 147, Centurion House, London Road, Staines-upon-Thames, Surrey, TW18 4AX

EC	REP
-----------	------------

E-CrossStu GmbH
Mainzer Landstr.69,
60329 Frankfurt am Main.



VEVOR

Affordable. Reliable. Home Improvement.

PODSTAWKA POD KIEROWNICĘ

MODEL: 6001

VEVOR

Affordable. Reliable. Home Improvement.

STEERING WHEEL STAND

Model:6001



To jest oryginalna instrukcja obsługi. Przed użyciem prosimy o dokładne zapoznanie się z treścią instrukcji. Firma VEVOR zastrzega sobie prawo do jednoznacznej interpretacji niniejszej instrukcji obsługi. Wygląd produktu zależy od stanu, w jakim go otrzymali Państwo. Prosimy o wyrozumiałość, ale nie będziemy Państwa ponownie informować o aktualizacjach technologicznych lub oprogramowania naszego produktu.



Ostrzeżenie: Aby zminimalizować ryzyko obrażeń, użytkownik powinien uważnie przeczytać instrukcję obsługi.





Uprzejmości

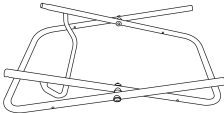
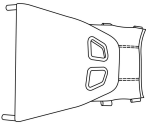
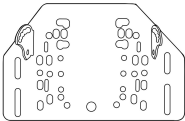



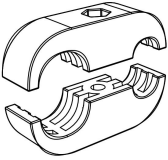

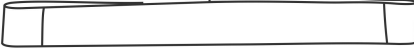
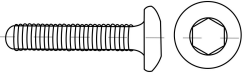
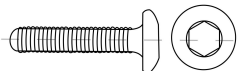
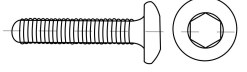
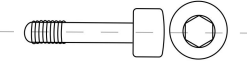
- Proszę zainstalować i używać stojak zgodnie z instrukcją .
- Dokonuj umiarkowanego montażu, unikaj silnych wibracji .
- Nie przechowywać w wilgotnych warunkach, wysokich temperaturach ani w miejscach zakurzonych .
- Produkt jest elastyczny, dlatego podczas montażu należy nosić rękawice robocze. Należy zachować ostrożność podczas instalacji, aby nie zranić dłoni.
- Dzieci powinny używać produktu pod nadzorem osoby dorosłej.

Zapisz instrukcję.

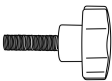
Lista części			
Kod	Zdjęcie	Nazwa	ILOŚĆ
1		Główny wspornik	1
2		Tył głowy	1
3		Panel kierownicy	1

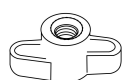
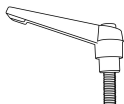
4		Część w kształcie litery U	1
5		6001 rama pedału dzielona w kształcie litery U	1
6		Wyreguluj część łączącą z ramą pedału	2
7		Złącze ramowe	4
8		6001 podzielony panel pedałów	1
9		Pręt podporowy zabezpieczający przed wywróceniem	1
10		Łączniki plastikowe (25/12)	1

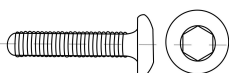
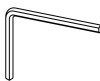
11		Łączniki plastikowe (25/16)	2
12		Pas mocujący	6
13		Pas podtrzymujący odcinek łądźziowy	1
A		Śruba M 8×20	2+1
B		Śruba M 6×25	8+1
C		Śruba M 6×35	4+1
D		Śruba M 6×35	4+1
mi		Nakrętka zabezpieczająca M6	8+1
F		Nakrętka kołnierзова M6	8+6

G		Śruba z łbem torx M6×15	2
H		Nakrętka motylkowa z rowkiem M6	2
I		Nakrętka motylkowa z rowkiem M8	2
J		Klucz kątowy M8× 16	2
K		Nakrętka kołnierzowa M8	2+1
L		Śruba M 6×16	12
M		Klucz imbusowy 5mm	1
N		otwarty koniec Klucz 10-13	1

Uwaga: 12 śrub M6*16 i 6 nakrętek M6 jest dostarczanych w komplecie.

★ Listę zestawów fotelików i sposobów ich montażu znajdziesz w załączonej instrukcji montażu fotelika.

KROK 1 :

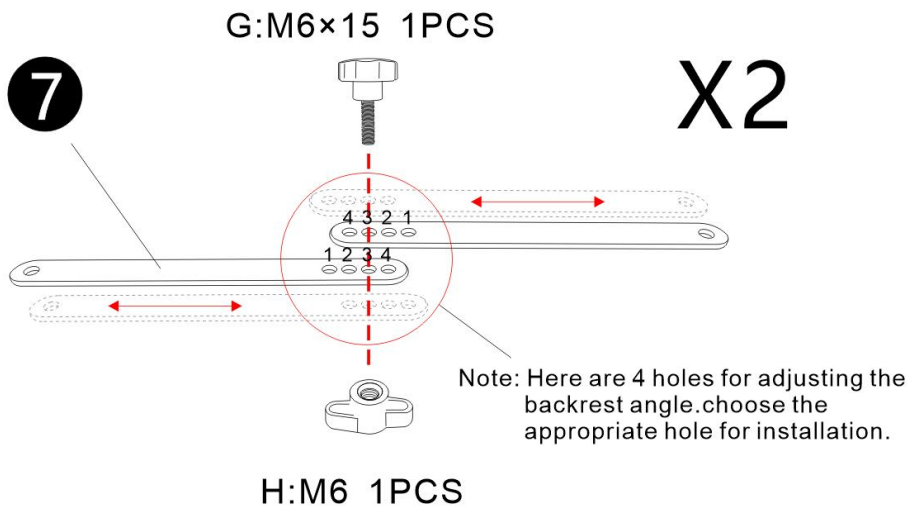

KROK 2:

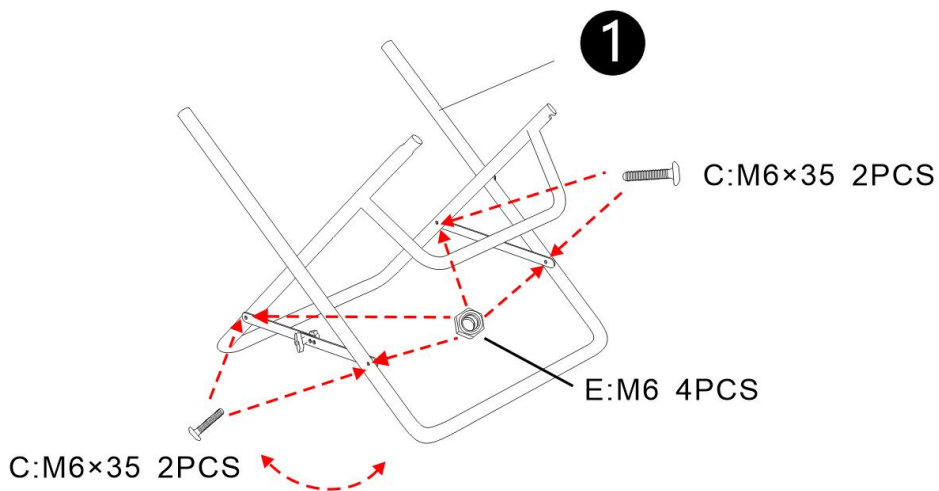

KROK 3:

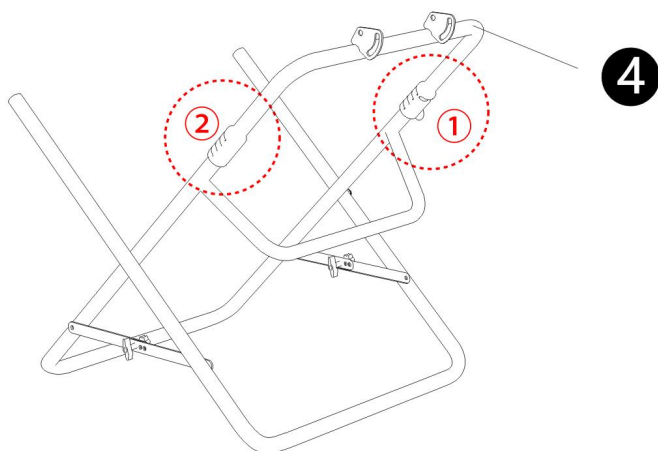

① Najpierw włóż 4 do lewej strony rurki ramy.



krok 1 : naciśnij sprężynę przycisku na długim boku 4, włóż długi bok 4 do klatka 1, po usłyszeniu dźwięku „kliknięcia” kulka wsuwa się do głównego gniazda ramki .

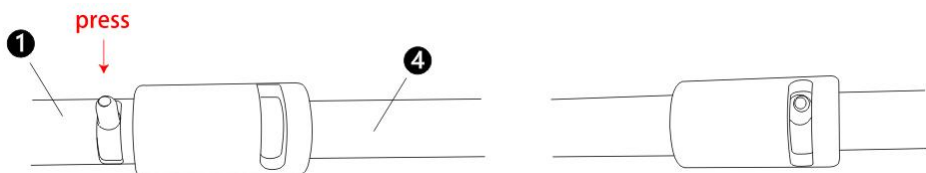

krok 2 : naciśnij ponownie przycisk sprężynowy, przesunij długą rurkę klamry bocznej do głównego rama, po usłyszeniu dźwięku „kliknięcia”

kulka wsuwa się w szczelinę rurki klamry .

② Następnie przymocuj 4 do drugiej strony rury ramy.

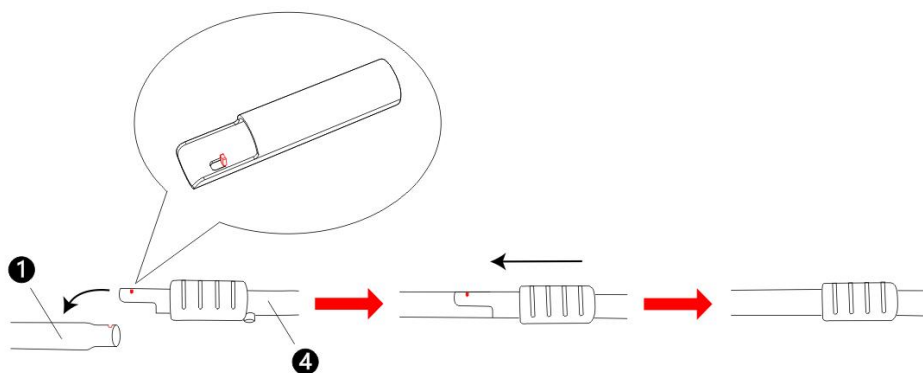

Krok 3 : Umieść wypustkę krótszego boku 4 w szczelinie ramy głównej i przesuń rurkę klamry krótkiego końca do ramy głównej

KROK 4:

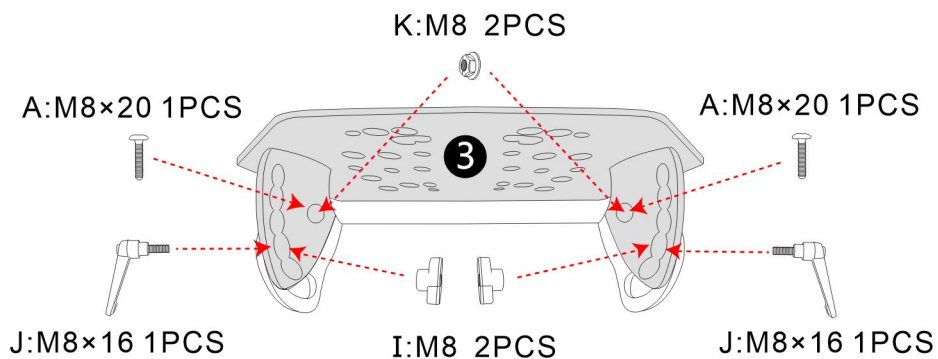
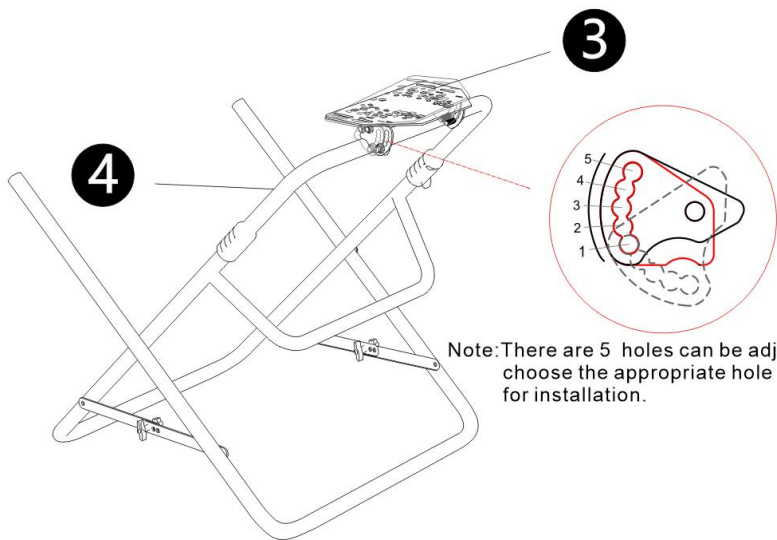

KROK 5:

D:M6×35 2PCS

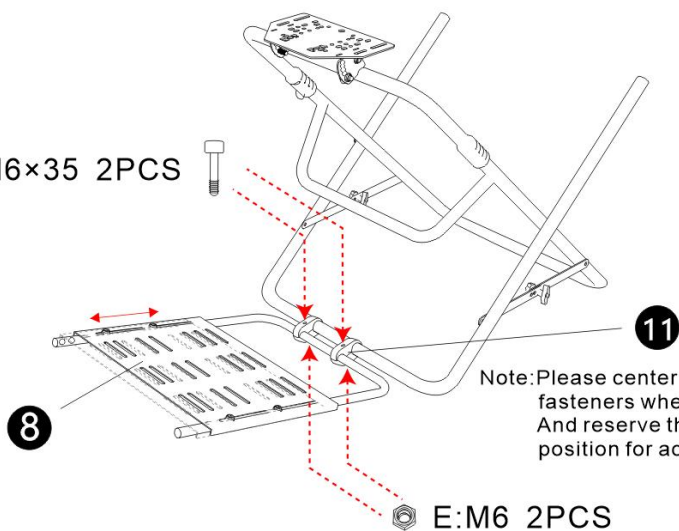

KROK 6:

D:M6×35 2PCS

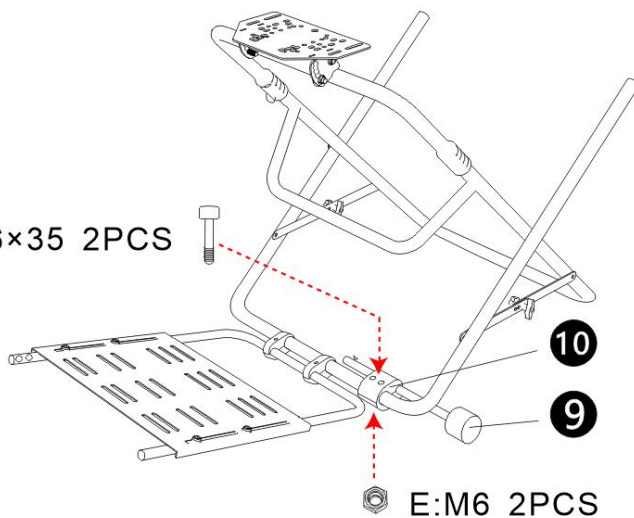

KROK 7:

X2

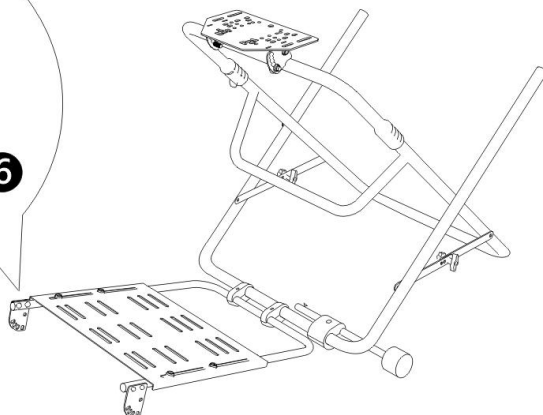
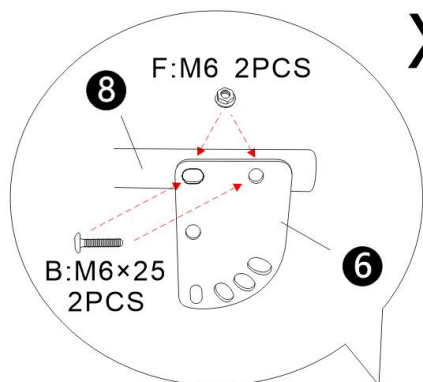

KROK 8:

X2

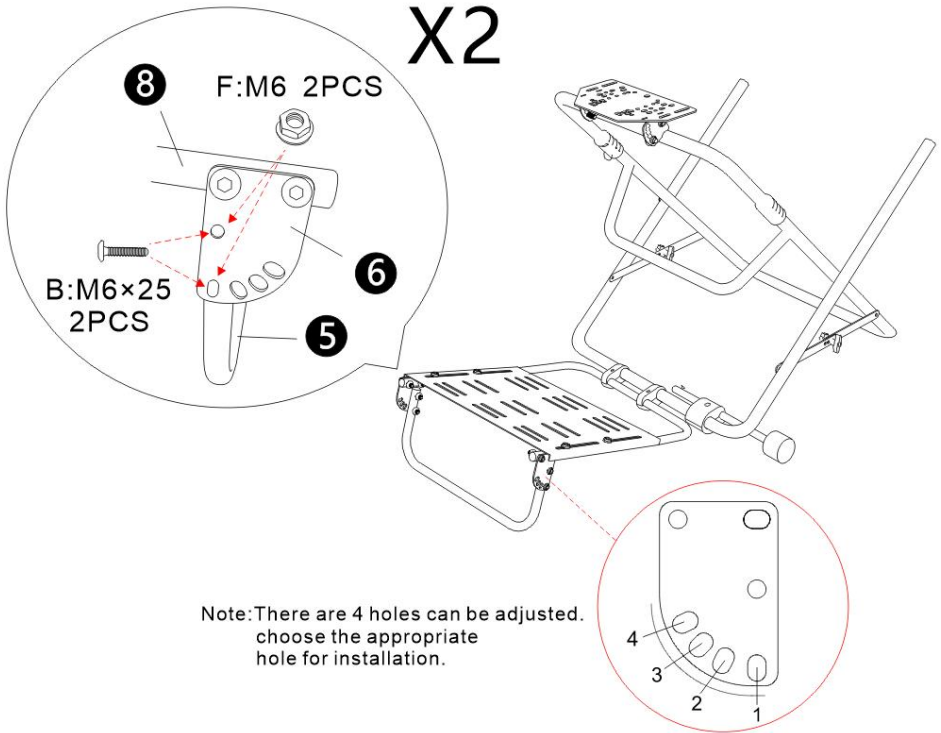

KROK 9:

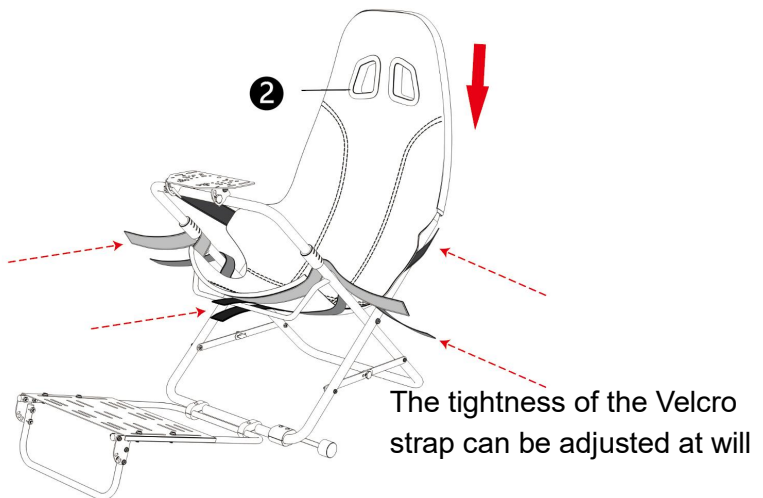

KROK 1 0:

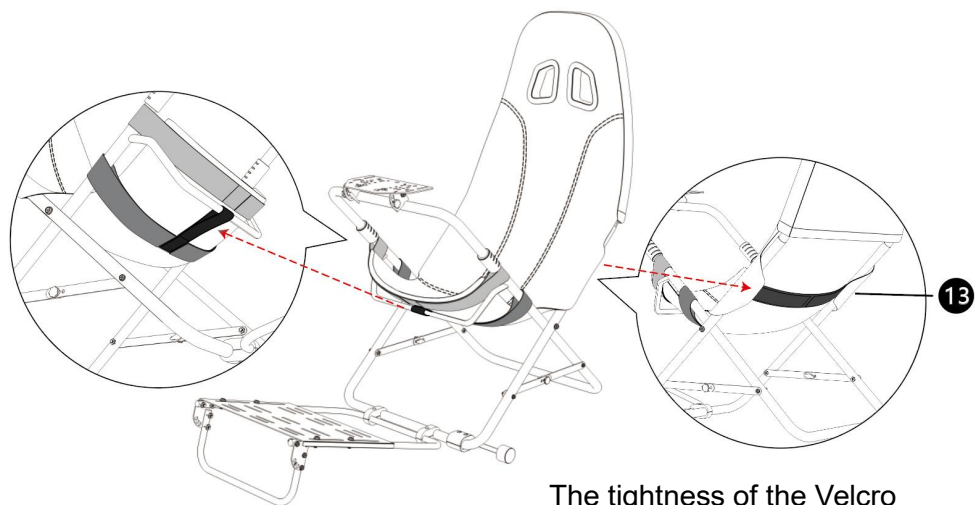

The tightness of the Velcro strap can be adjusted at will

Kompletny montaz



Producent: Shanghaimuxinmuyeyouxiangongsi

Adres: Shuangchenglu 803nong11hao1602A-1609shi, baoshanqu, szanghaj 200000 CN.

Importowane do AUS: SIHAO PTY LTD. 1 ROKEVA
STREETEASTWOOD
NSW 2122 Australia

Importowane do USA: Sanven Technology Ltd. Suite 250, 9166 Anaheim
Miejsce, Rancho Cucamonga, CA 91730

UK	REP
-----------	------------

YH CONSULTING LIMITED. C/O YH Consulting
Limited Office 147, Centurion House, London
Road, Staines-upon-Thames, Surrey, TW18 4AX

EC	REP
-----------	------------

E-CrossStu GmbH
Mainzer Landstr.69,
60329 Frankfurt am Main.



VEVOR

Affordable. Reliable. Home Improvement.

STUURWIELSTANDAARD

MODEL: 6001

VEVOR

Affordable. Reliable. Home Improvement.

STEERING WHEEL STAND

Model:6001



Dit is de originele handleiding. Lees alle instructies zorgvuldig door voordat u het product gebruikt. VEVOR behoudt zich het recht voor om de gebruiksaanwijzing duidelijk te interpreteren. Het uiterlijk van het product is afhankelijk van het product dat u hebt ontvangen. Neemt u het ons niet kwalijk dat we u niet meer op de hoogte stellen van eventuele technologische of software-updates voor ons product.





Waarschuwing: om het risico op letsel te verminderen, moet de gebruiker de gebruiksaanwijzing zorgvuldig lezen.



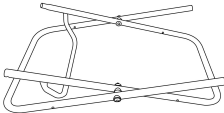
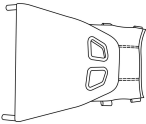
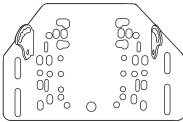

Aandacht

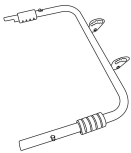

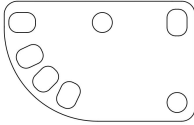
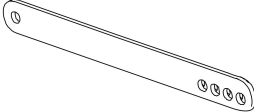
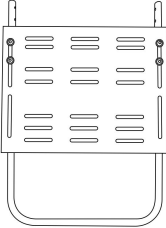
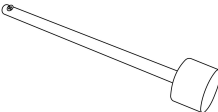
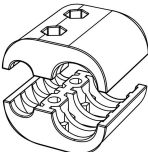
- Installeer en gebruik de standaard volgens de instructies .
- Installeer het voorzichtig en vermijd sterke trillingen .
- Niet bewaren op een vochtige plaats, bij hoge temperaturen of op een stoffige plaats .
- De productstructuur is flexibel. Draag werkhandschoenen tijdens de montage. Let op een pijnlijke hand tijdens de installatie.
- Kinderen dienen dit product onder toezicht van een volwassene te gebruiken.

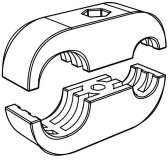
Bewaar de handleiding.

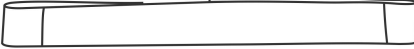
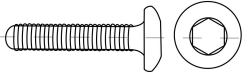
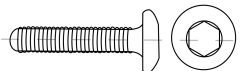
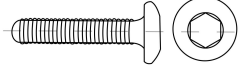
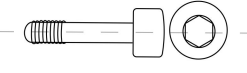
Onderdelenlijst			
Code	Afbeelding	Naam	AANTAL
1		Hoofdbeugel	1
2		Achterkant van het hoofd	1
3		Stuurwielpaneel	1

4		U-vormig onderdeel	1
5		6001 split pedaalframe - U-vormig	1
6		Pas het verbindingsstuk voor het pedaalframe aan	2
7		Frame connector	4
8		6001 split pedaalpaneel	1
9		Anti-kantelsteunstan- g	1
10		Kunststof bevestigingsmiddele- n (25/12)	1

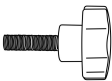
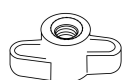
11		Kunststof bevestigingsmidde- len (25/16)	2
12		Vastzetriem	6
13		Lendensteungordel	1
A		Schroef M 8x20	2+1
B		Schroef M 6x25	8+1
C		Schroef M 6x35	4+1
D		Schroef M 6x35	4+1
E		Borgmoer M6	8+1
F		Flensmoer M6	8+6

G		Torx-handgreepschroef M6×15	2
H		Gegroefde vleugelmoer M6	2
I		Gegroefde vleugelmoer M8	2
J		L-vormige sleutel M8× 16	2
K		Flensmoer M8	2+1
L		Schroef M 6×16	12
M		Inbussleutel 5mm	1
N		open einde Sleutel 10-13	1

Let op: 12 schroeven M6*16 en 6 moeren M6 zijn inbegrepen.

★ Raadpleeg de bijgevoegde handleiding met de stoelinstallatieprocedure voor een lijst met stoelsets en de installatie ervan.

STAP 1 :

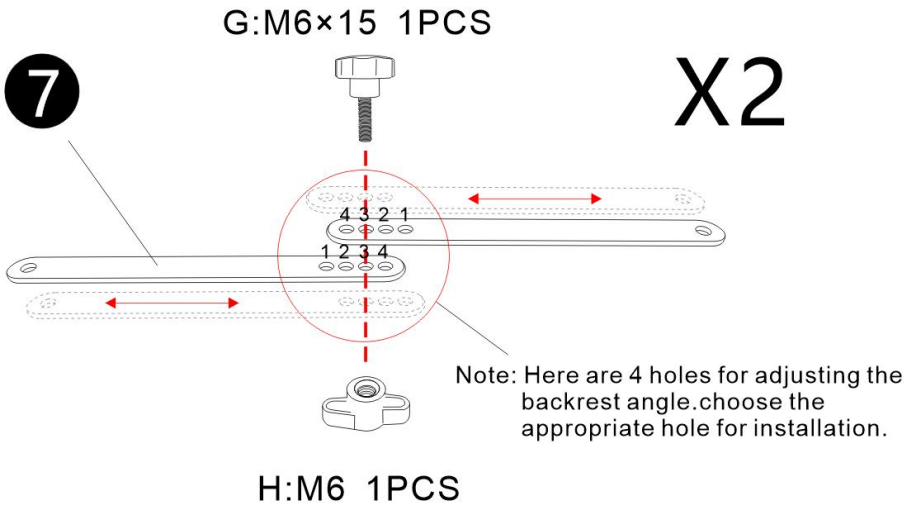

STAP 2:

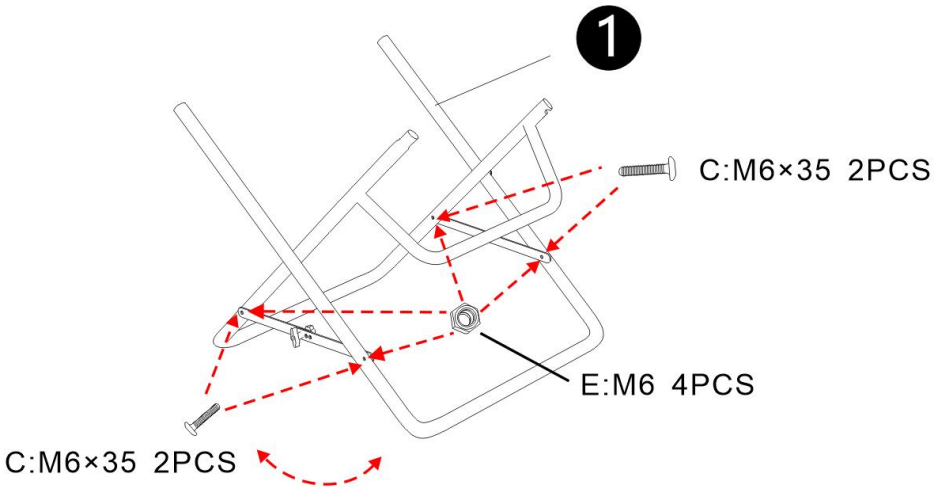

STAP 3:

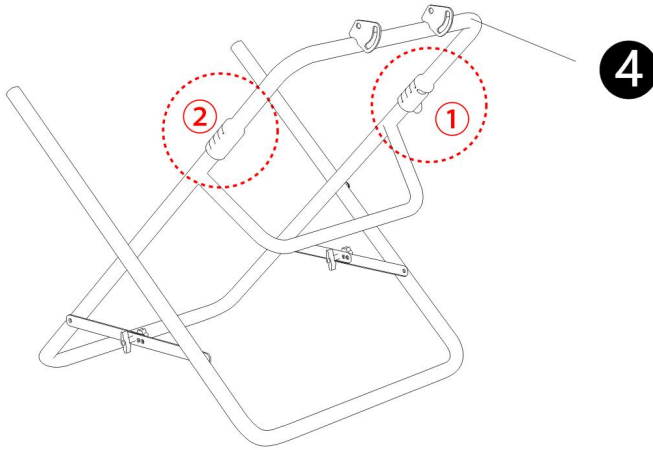

① Plaats eerst 4 in de linkzijdige van de framebuis.



stap 1 : druk op de knopveer aan de lange zijde van 4, steek de lange zijde van 4 in de frame 1, zodra u een "klik"-geluid hoort, schuift de knikker in de gleuf van het hoofdframe .

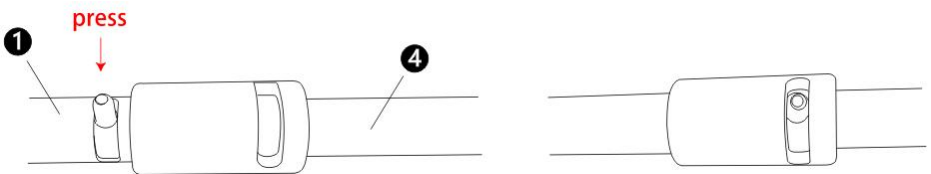

stap 2 : Druk nogmaals op de knopveer, schuif de lange zijgespbuis naar de hoofd frame, wanneer u een "klik"-geluid hoort, glijdt de knikker in de gleuf van de gespbuis .

2 Bevestig vervolgens 4 aan de andere kant van de framebuis.

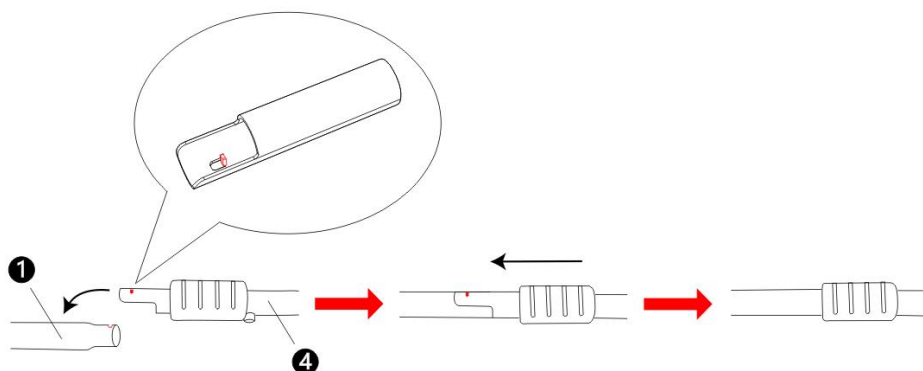

stap 3 : Plaats de bult van de korte zijde 4 in de sleuf van het hoofdframe en schuif de gespbuis van het korte uiteinde in het hoofdframe

STAP 4:

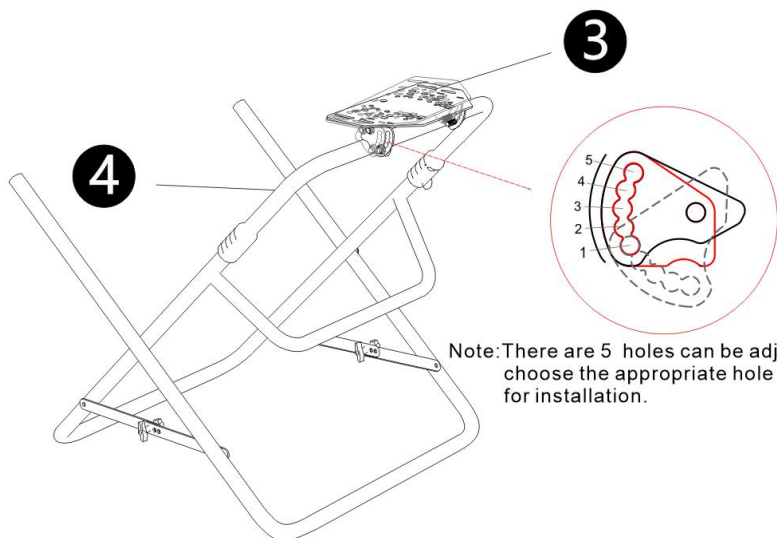

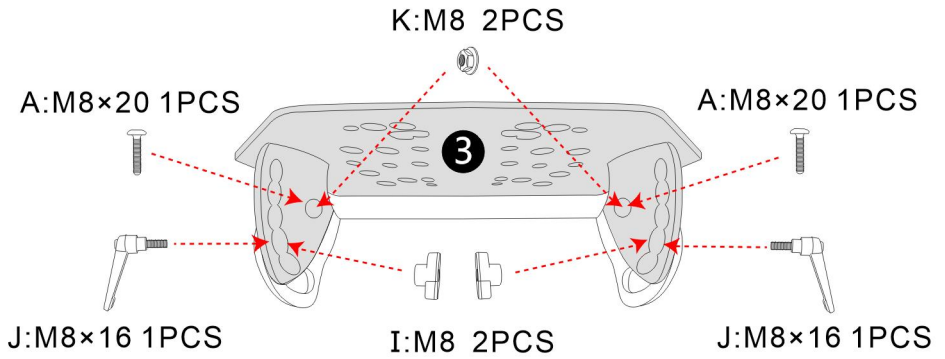

STAP 5:

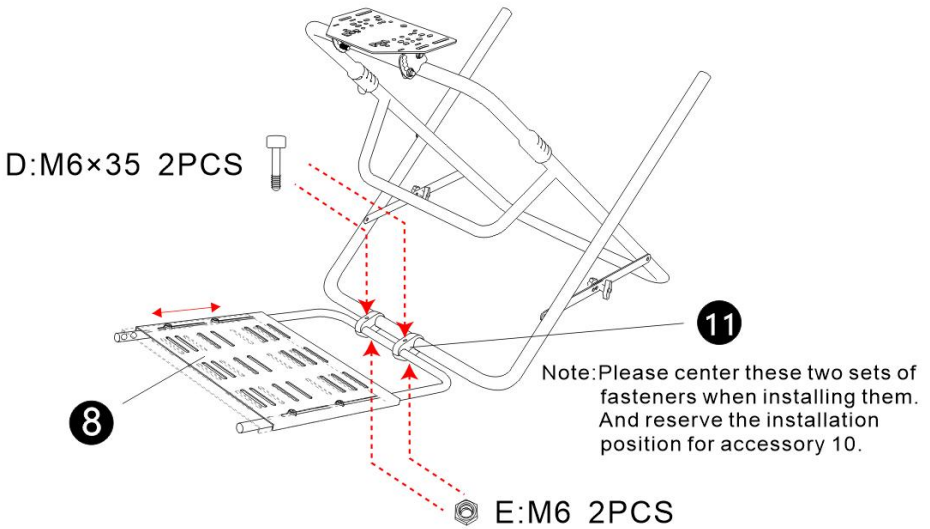

STAP 6:

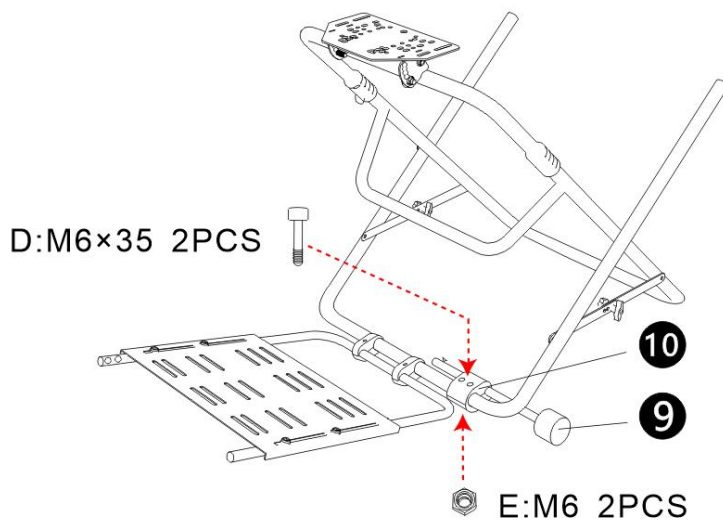

STAP 7:

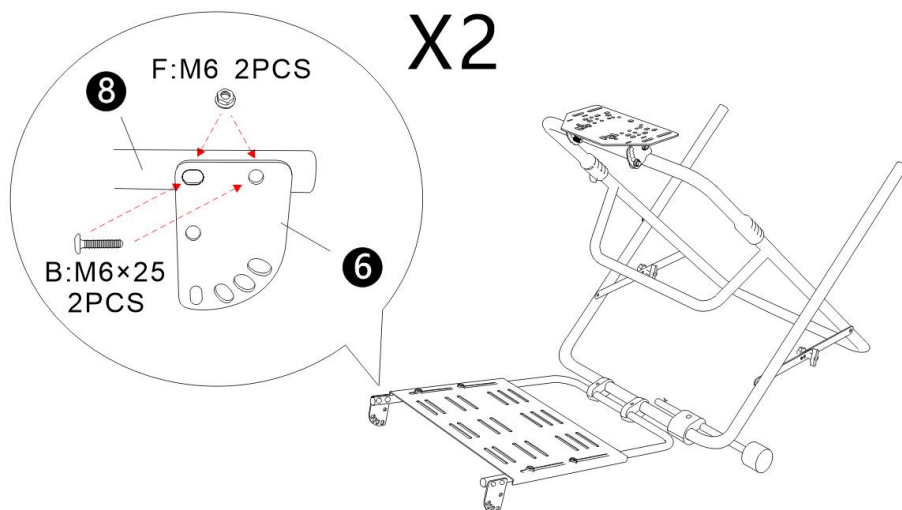

STAP 8:

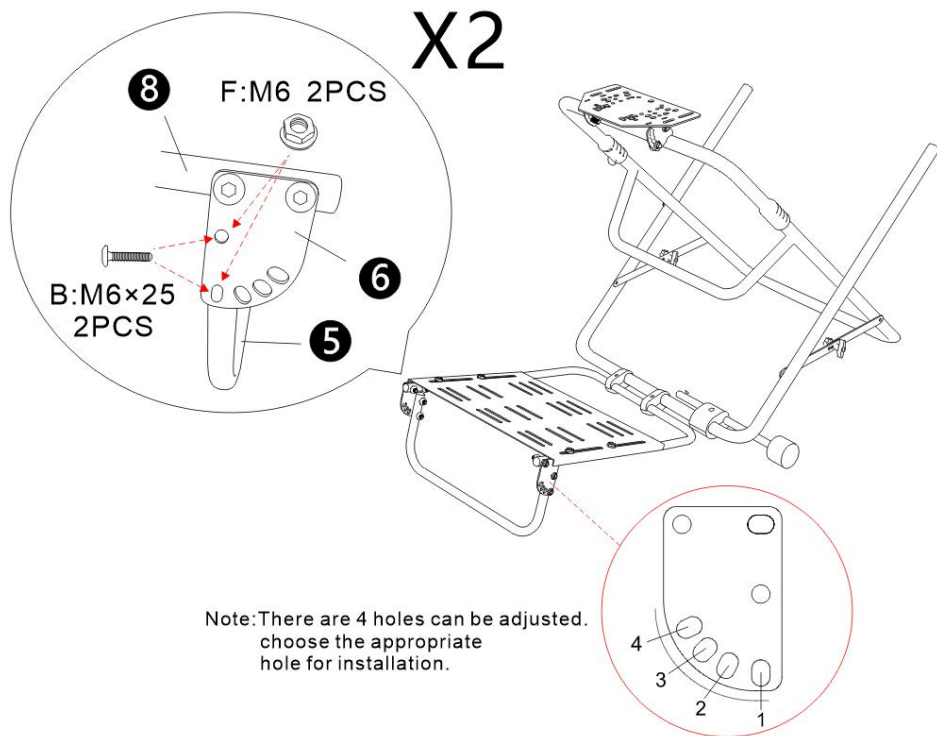

STAP 9:

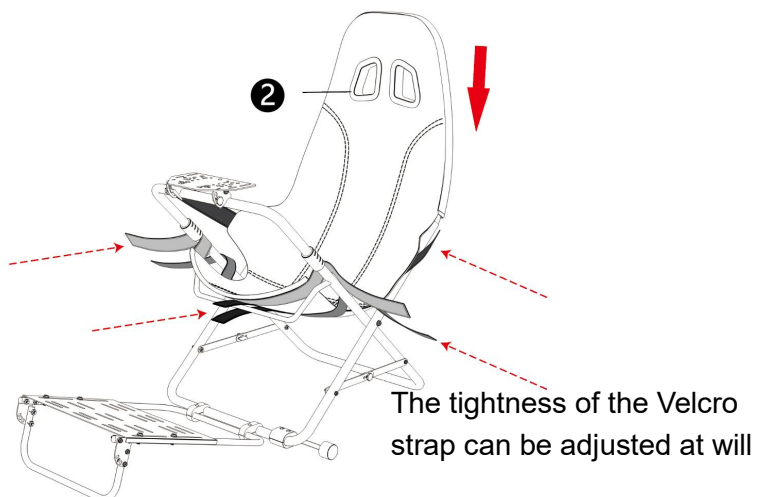

STAP 1 0:

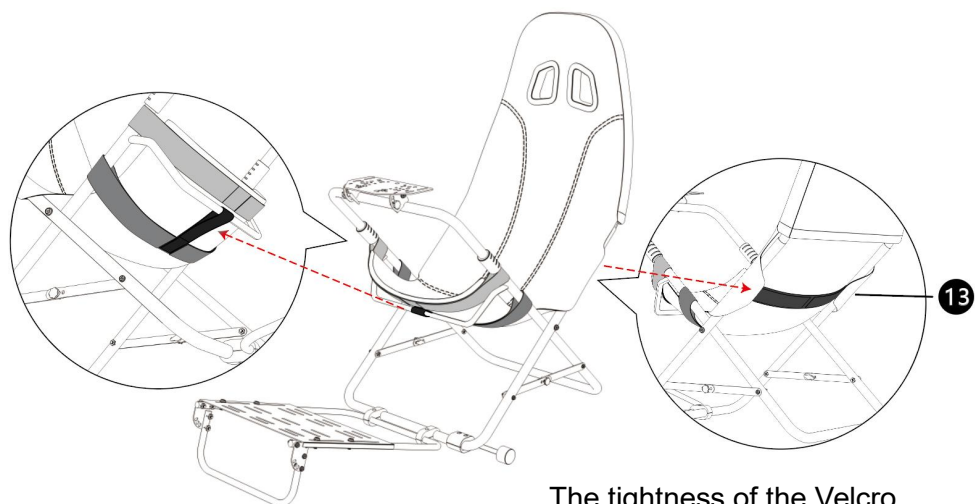

The tightness of the Velcro strap can be adjusted at will

Volledige montage



Fabrikant: Shanghaimuxinmuyeyouxiangongsi

Adres: Shuangchenglu 803nong11hao1602A-1609shi, baoshanqu, shanghai 200000 CN.

Geïmporteerd naar AUS: SIHAO PTY LTD. 1 ROKEVA

STREETEASTWOOD

NSW 2122 Australië

Geïmporteerd naar de VS: Sanven Technology Ltd. Suite 250, 9166

Anaheim

Plaats, Rancho Cucamonga, CA 91730

UK	REP
-----------	------------

YH CONSULTING LIMITED. C/O YH Consulting
Limited Office 147, Centurion House, London
Road, Staines-upon-Thames, Surrey, TW18 4AX

EC	REP
-----------	------------

E-CrossStu GmbH
Mainzer Landstr.69,
60329 Frankfurt am Main.



VEVOR

Affordable. Reliable. Home Improvement.

RATTSTYCK

MODELL: 6001

VEVOR

Affordable. Reliable. Home Improvement.

STEERING WHEEL STAND

Modell: 6001



Detta är originalinstruktionerna, vänligen läs alla instruktioner noggrant innan du använder produkten. VEVOR förbehåller sig en tydlig tolkning av vår användarmanual. Produktens utseende ska vara beroende av den produkt du mottagit. Vi ber om ursäkt för att vi inte kommer att informera dig igen om det finns några teknik- eller programuppdateringar för vår produkt.





Varning – För att minska risken för skador måste användaren läsa instruktionsmanualen noggrant.



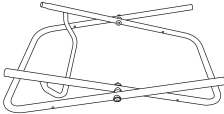
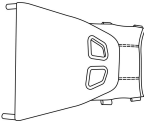
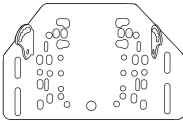

Uppmärksamhet

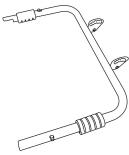

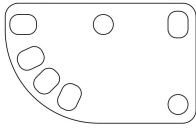
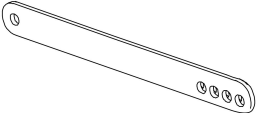
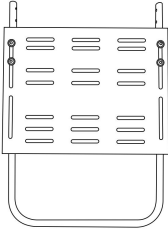
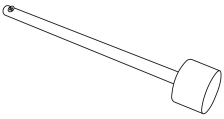
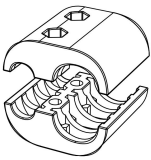

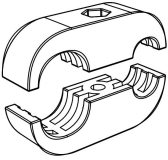

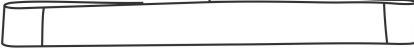
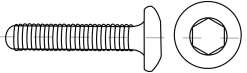
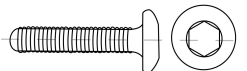
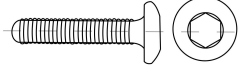
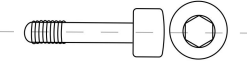
- Installera och använd stativet enligt anvisningarna .
- Installera med måtta och undvik starka vibrationer .
- Förvara inte i fuktiga förhållanden, höga temperaturer eller dammiga platser .
- Produktstrukturen är flexibel, använd arbetshandskar vid montering. Var försiktig med värkande händer vid installation.
- Barn bör vara under vuxenövervakning när de använder produkten.

Spara manualen.

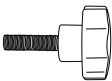
Dellista			
Koda	Bild	Namn	ANTAL
1		Huvudfäste	1
2		Baksidan av huvudet	1
3		Rattpanel	1

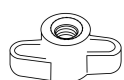
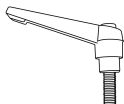
4		U-formad del	1
5		6001delad pedalram - U-formad	1
6		Justera anslutningsdelen för pedalramen	2
7		Ramkoppling	4
8		6001 delad pedalpanel	1
9		Stödstång som motverkar vältning	1
10		Plastfästen (25/12)	1

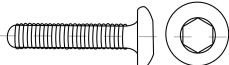
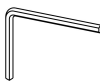
11		Plastfästen (25/16)	2
12		Spännrem	6
13		Ländryggsstödsbälte	1
En		Skruv M8 x20	2+1
B		Skruv M6 x25	8+1
C		Skruv M6 x35	4+1
D		Skruv M6 x35	4+1
E		Låsmutter M6	8+1
F		Flänsmutter M6	8+6

G		Torx-handtagsskruv M6×15	2
H		Spårad tummutter M6	2
Jag		Spårad tummutter M8	2
J		L-formad nyckel M8× 16	2
K		Flänsmutter M8	2+1
L		Skruv M6 ×16	12
M		Sextaktsnyckel 5 mm	1
N		öppen ände Skiftnyckel 10-13	1

Obs: 12 st. skruvar M6*16 och 6 st. muttrar M6 medföljer utan extra kostnad.

★ För en lista över sitsatser och installation, se den bifogade manualen för sitsinstallationen.

STEP 1 :

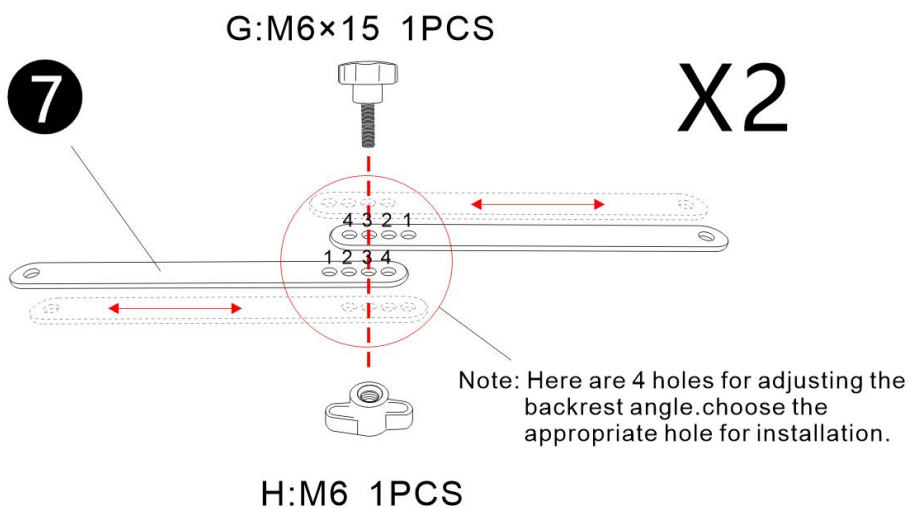

STEP 2:

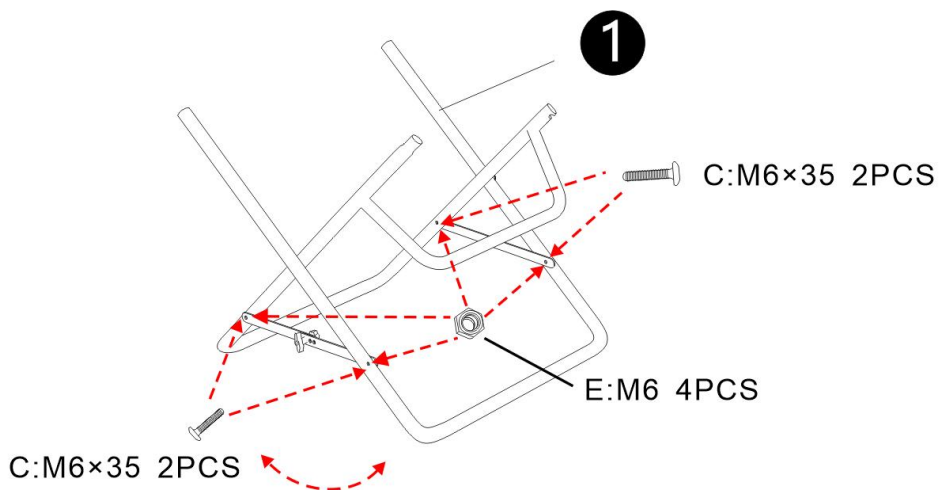

STEG 3:

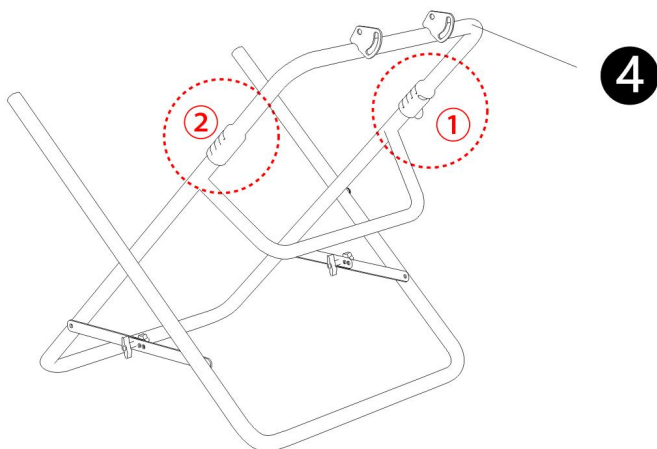

① För först in 4 i vänster sida av ramröret.

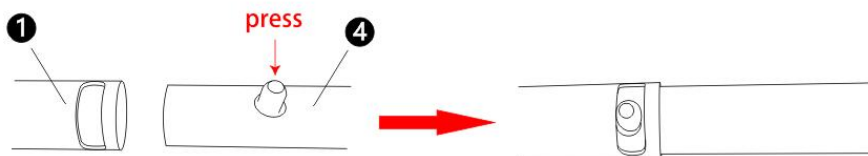

steg 1 : tryck på knappfjäders på långsidan av 4:an, för in långsidan av 4:an i Ram 1, när du hör ett "klick"-ljud glider kulan in i huvudramens springa .

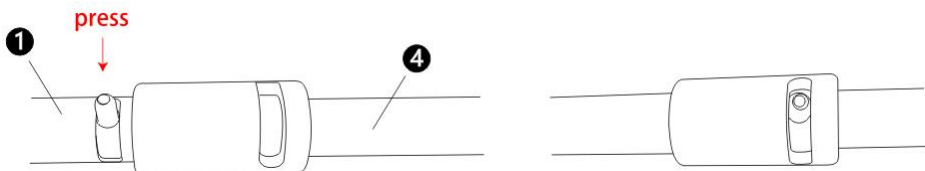

steg 2 : tryck på knappfjäders igen, skjut spännets långa sidospännesrör till huvudspännets ram, när du hör ett "klick"-ljud, glider kulan in i spännets rörhål .

2 Fäst sedan 4 på den andra sidan av ramröret.

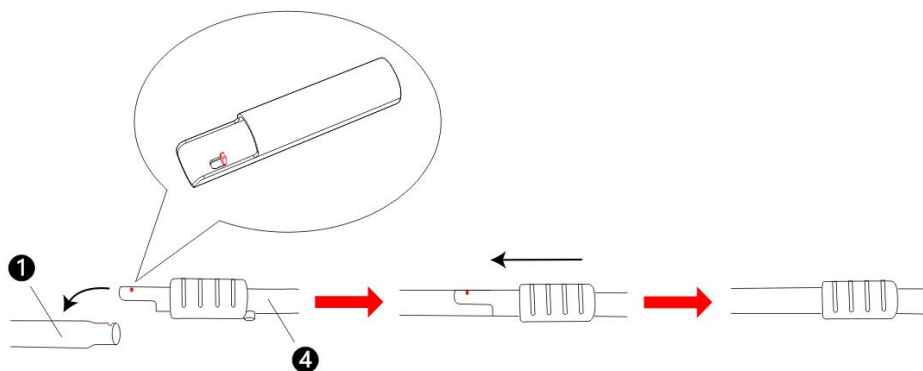

Steg 3 : Placera den korta sidans upphöjning 4 i springan på huvudramen och skjut in den spännröret på den korta änden in i huvudramen

STEG 4:

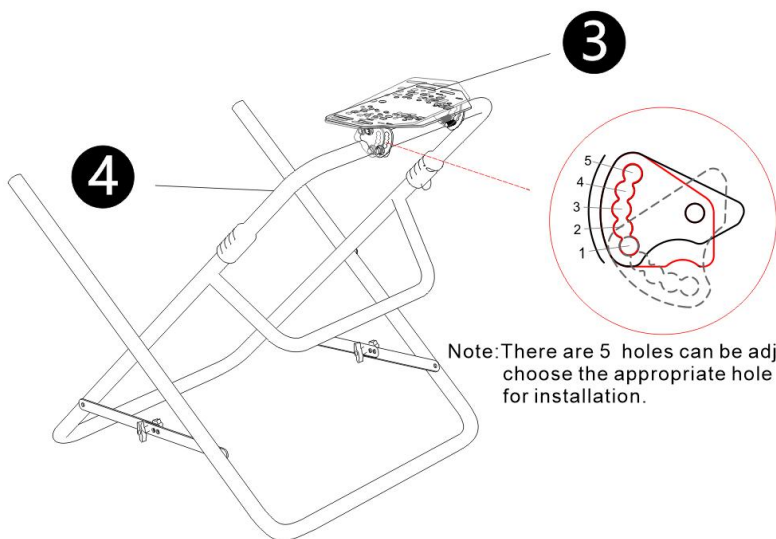

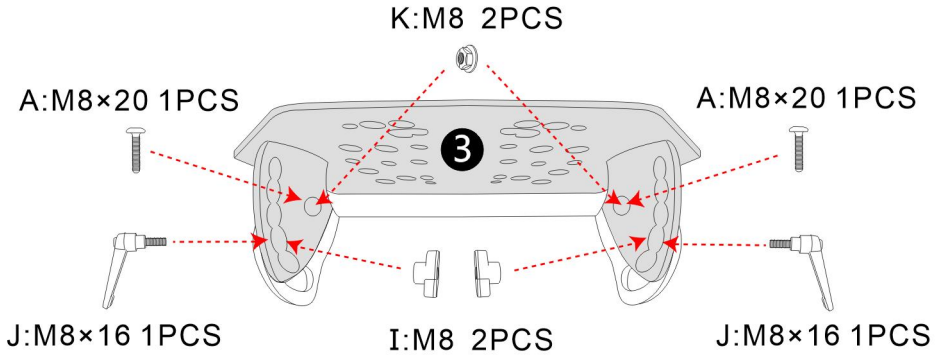

STEP 5:

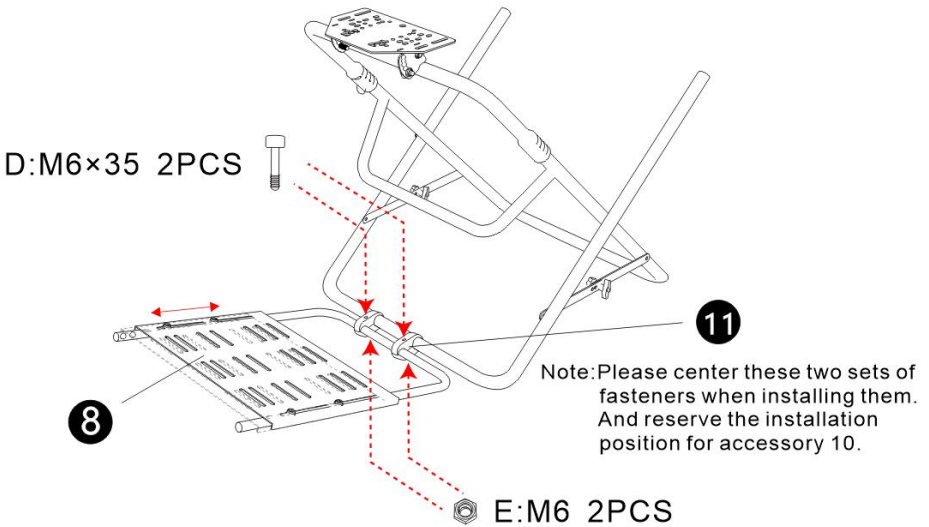

STEP 6:

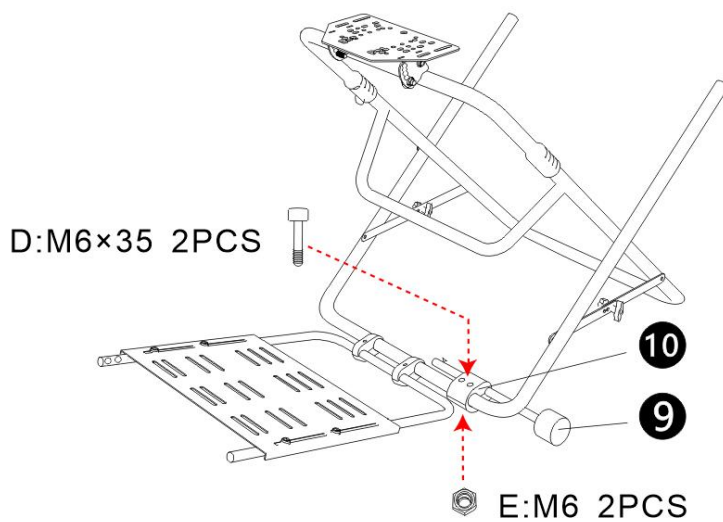

STEP 7:

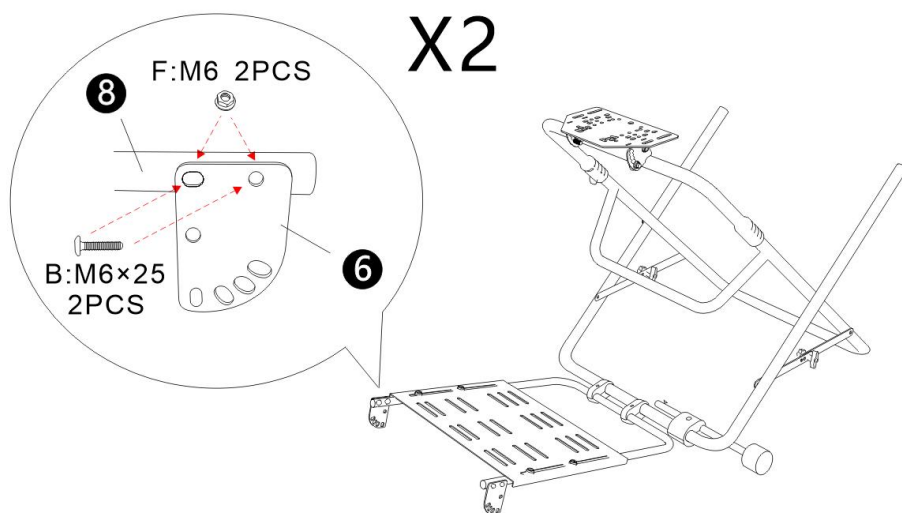

STEG 8:

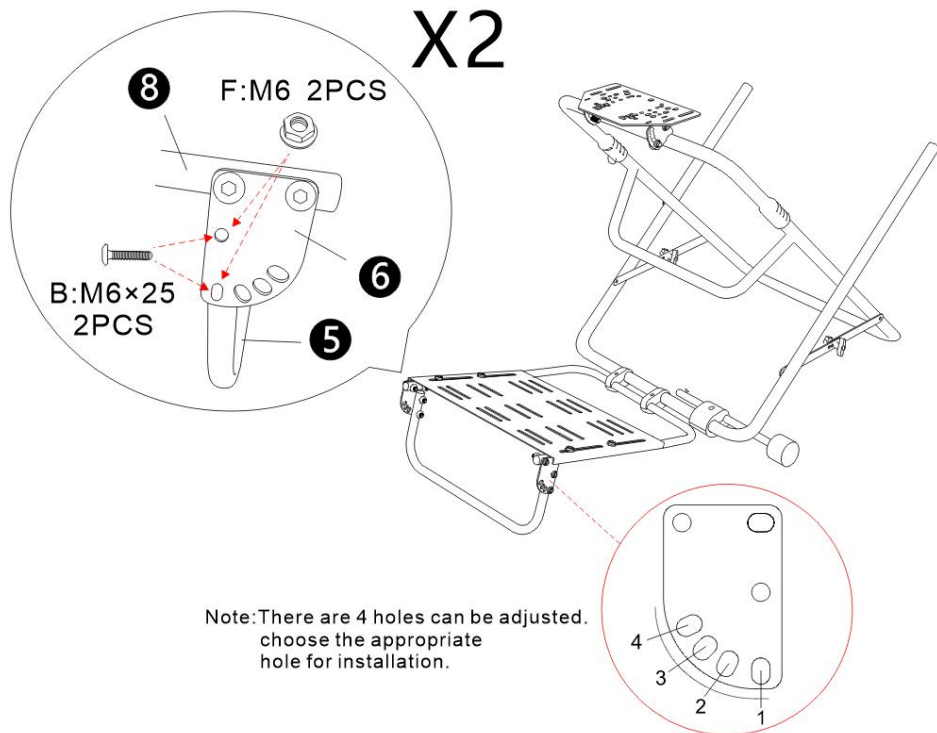

STEG 9:

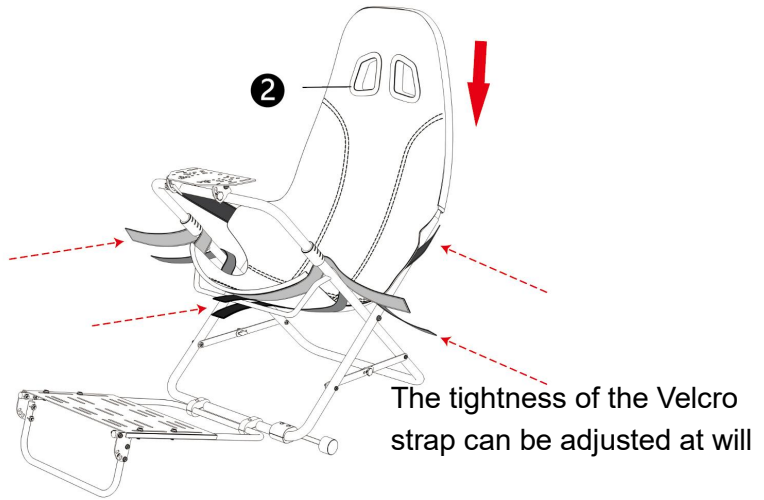

STEG 1 0:

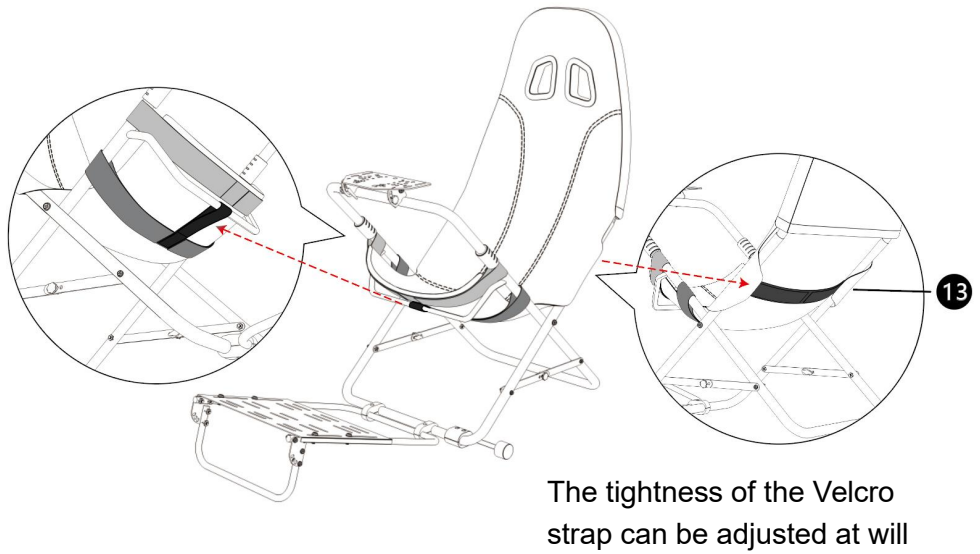

Komplett montering



Tillverkare: Shanghaimuxinmuyeyouxiangongsi

Adress: Shuangchenglu 803nong11hao1602A-1609shi, baoshanqu, Shanghai 200 000 kanadensiska republiken.

Importerad till Australien: SIHAO PTY LTD. 1 ROKEVA STREETEASTWOOD

NSW 2122 Australien

Importerad till USA: Sanven Technology Ltd. Suite 250, 9166 Anaheim Plats, Rancho Cucamonga, Kalifornien 91730

UK	REP
-----------	------------

YH CONSULTING LIMITED. C/O YH Consulting Limited Office 147, Centurion House, London Road, Staines-upon-Thames, Surrey, TW18 4AX

EC	REP
-----------	------------

E-CrossStu GmbH
Mainzer Landstr.69,
60329 Frankfurt am Main.

