

# **VEVOR**

**Affordable. Reliable. Home Improvement.**

## **STEERING WHEEL STAND**

**MODEL: 6013**



# VEVOR

Affordable. Reliable. Home Improvement.

## STEERING WHEEL STAND

**Model:6013**



This is the original instruction, please read all manual instructions carefully before operating. VEVOR reserves a clear interpretation of our user manual. The appearance of the product shall be subject to the product you received. Please forgive us that we won't inform you again if there are any technology or software updates on our product.







**Warning-**To reduce the risk of injury, user must read instructions manual carefully.

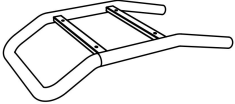
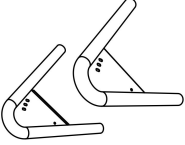
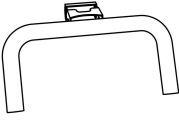
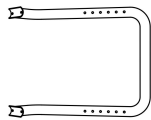

## Attentions

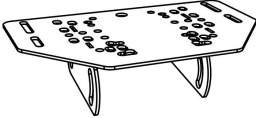
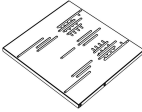
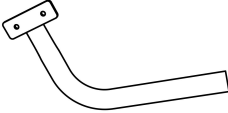
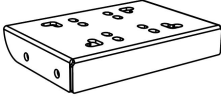
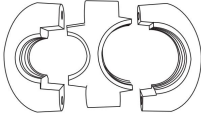

- Please install and use the stand according to instruction.
  - Please install moderately, avoid strong vibration.
  - Don't keep in humid conditions, high temperatures, or a dusty location.
  - The product structure is flexible, wear work gloves during assembly.
- Please take care of a hurting hand when installing .
- Children should be under adult supervision when using the product.



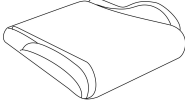
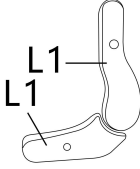
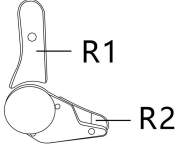
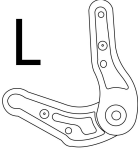

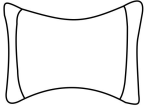
## Save the manual.

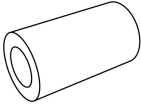
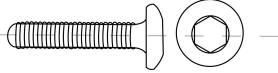
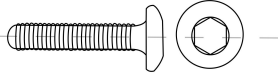
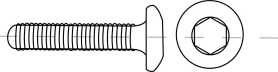
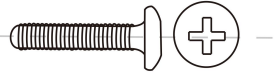
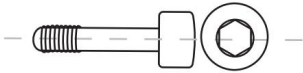
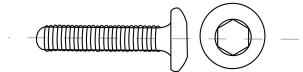

Part List			
Code	Picture	Name	QTY.
1		pedestal	1
2		V-shaped connection elbow	1
3		U-shaped part	1
4		6013 monitor- U-shaped bracket	1

5		6013 monitor- Vertical slide vane	2
6		6013 monitor- Crossbar steel plate	1
7		Steering Wheel Panel	1
8		Pedal panel	1
9		Gear lever holder	1
10		Gear lever panel	1
11		Plastic fasteners	2
12		Tie-down strap	6

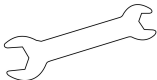
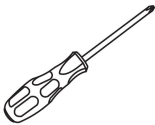
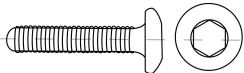
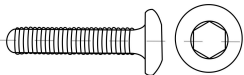
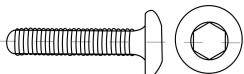
13		back	1
14		seat	1
15		Angle adjuster plastic cover - left	1
16		Angle adjuster plastic cover - right	1
17		recliner-left	1
18		recliner-right	1
19		Headrest pillow	1

20		Lumbar pillow	1
A		Pipe Support Pad	4
B		Plastic cylinder	4
C		Screw M8×20	4+1
D		Screw M8×45	4+1
E		Screw M8×60	4+1
F		Screw M5×30	2+1
G		Screw M6×55	4+1
H		Screw M6×16	12

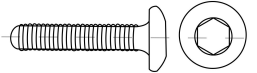
I		Flange nut M8	8+1
J		Flange nut M6	2+6
K		Hex wrench 5mm	1
L		10-13 open-end spanner	1
M		Screwdriver	1
N		Screw M6×30	4+1
O		Screw M6×20	6+1
a		Screw M8×25	8+1
b		Screw M5×8	6+1

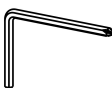
d		Screw M8x35	4+1
e		Spring washer M8	8+1
f		Flat washer M8	4+1
g		Ring spanner 5mm	1

**Note:** 12pcs screws M6\*16 and 6pcs nuts M6 are complimentary.

★ For the list of seat kits and installation, please refer to the seat installation procedure manual attachment.

**STEP 1:**

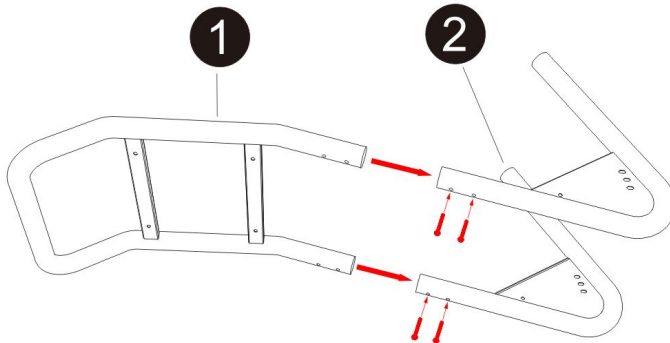

O:M6×20 4PCS

**STEP 2:**

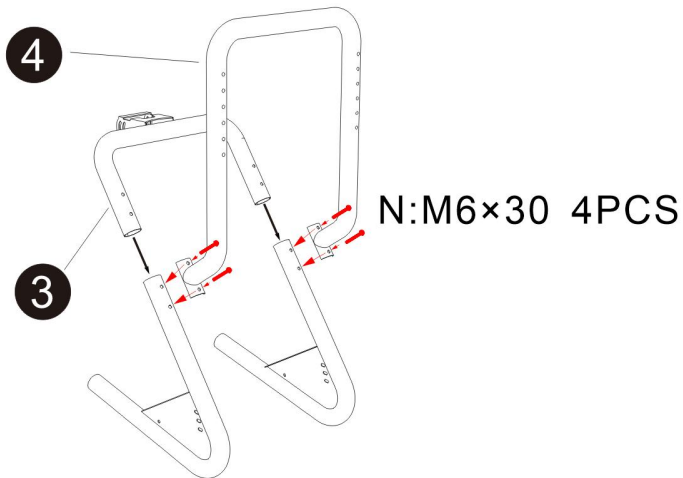

**STEP 3:**

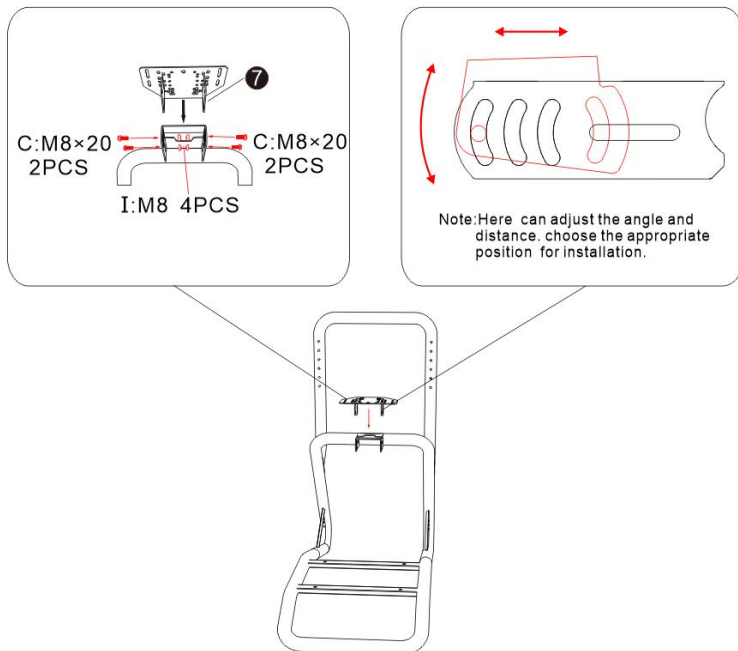

**STEP 4:**

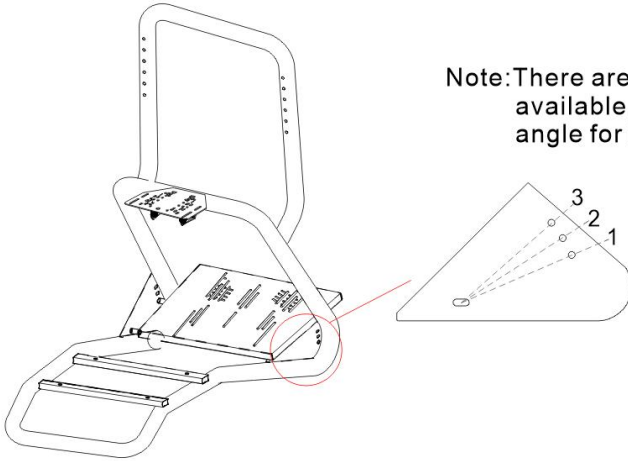

Note: There are 3 adjustable angles available. choose the appropriate angle for installation.

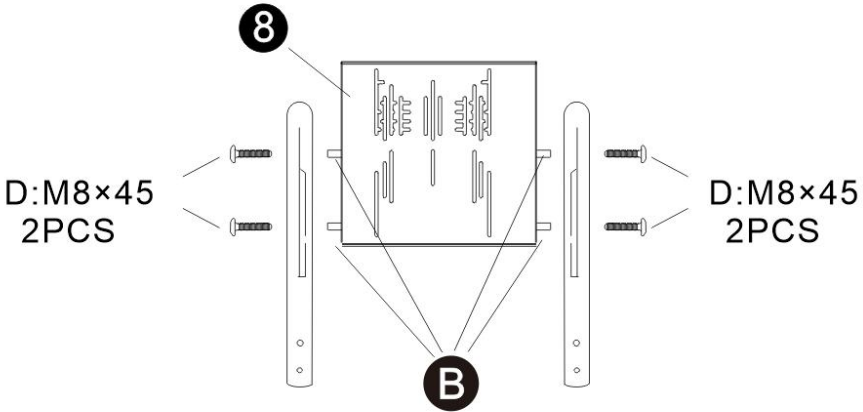

**Bottom**

**STEP 5:**

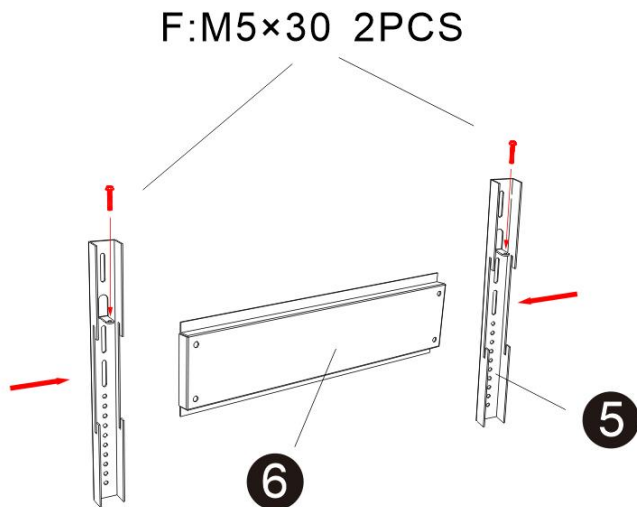

**STEP 6:**

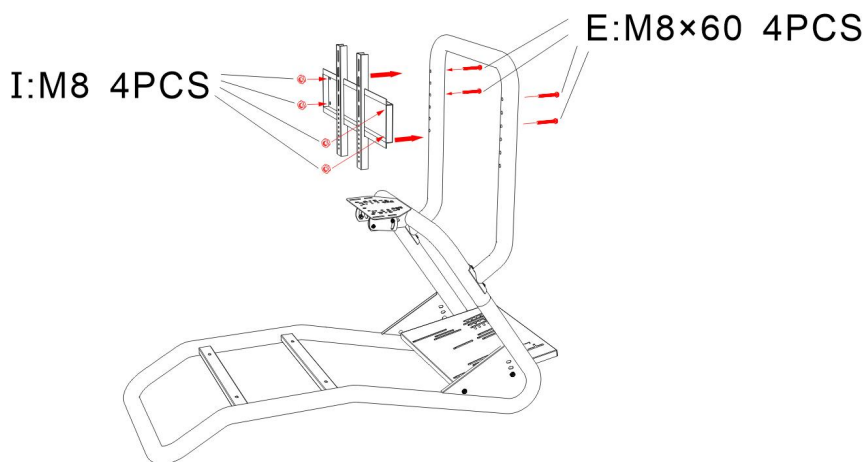

**STEP 7:**

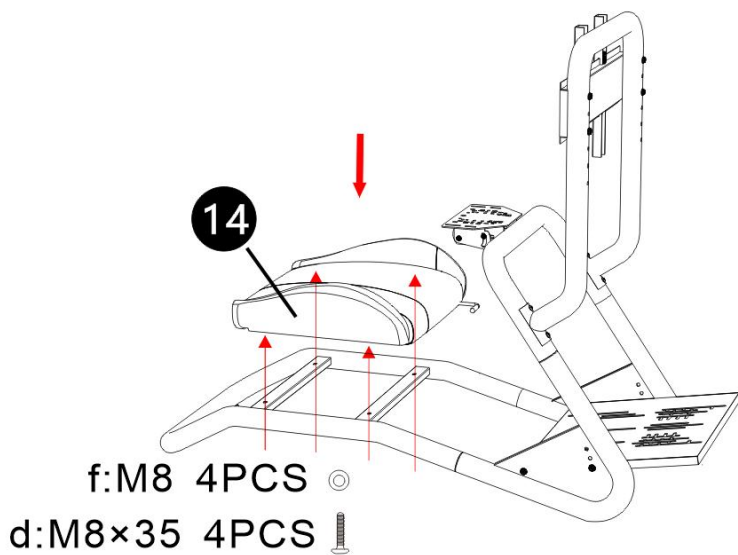

**STEP 8:**

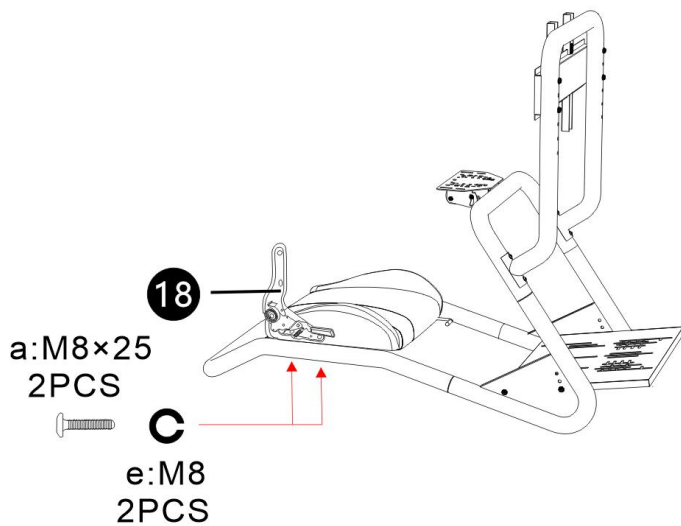

**STEP 9:**

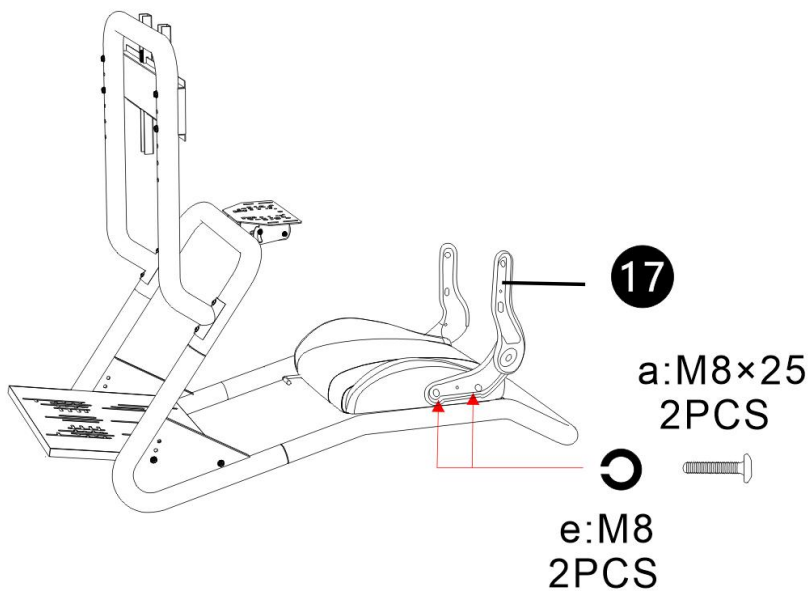

**STEP 10:**

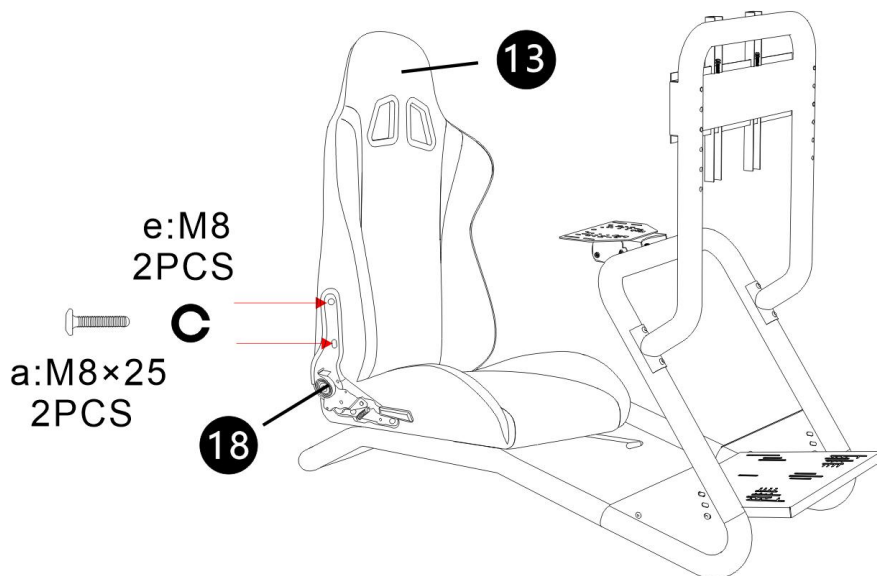

**STEP 11:**

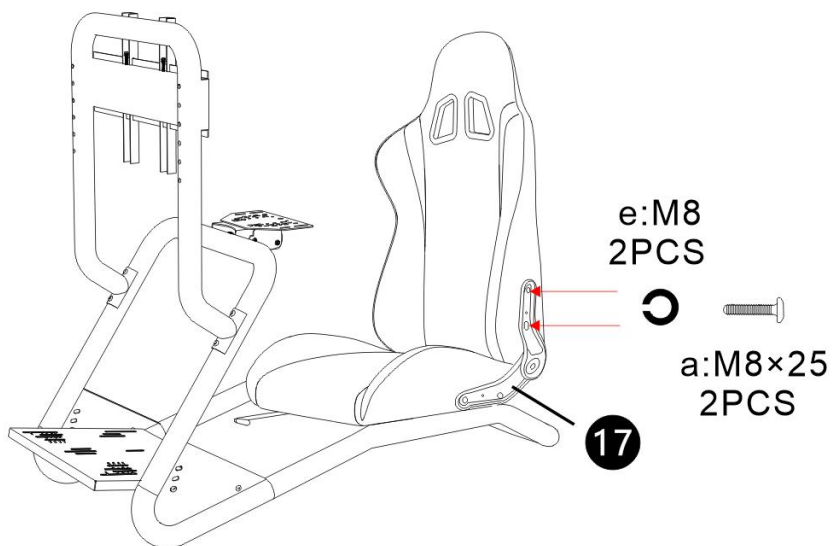

**STEP 12:**

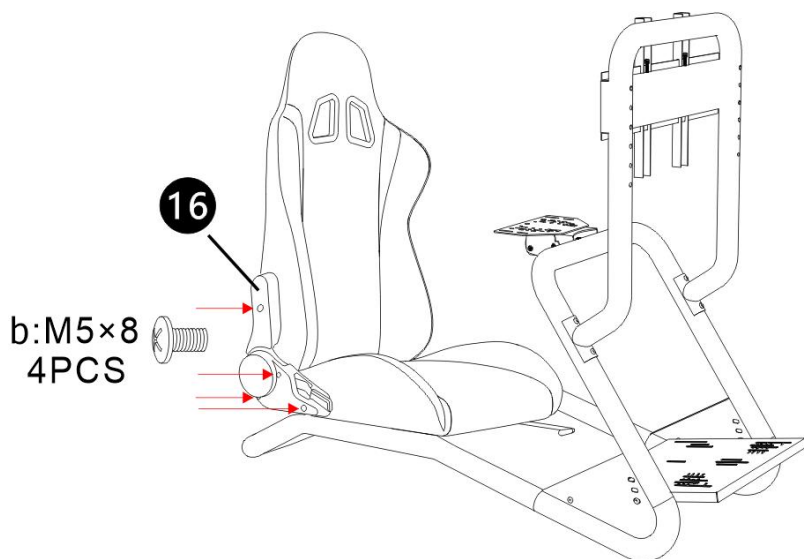

**STEP 13:**

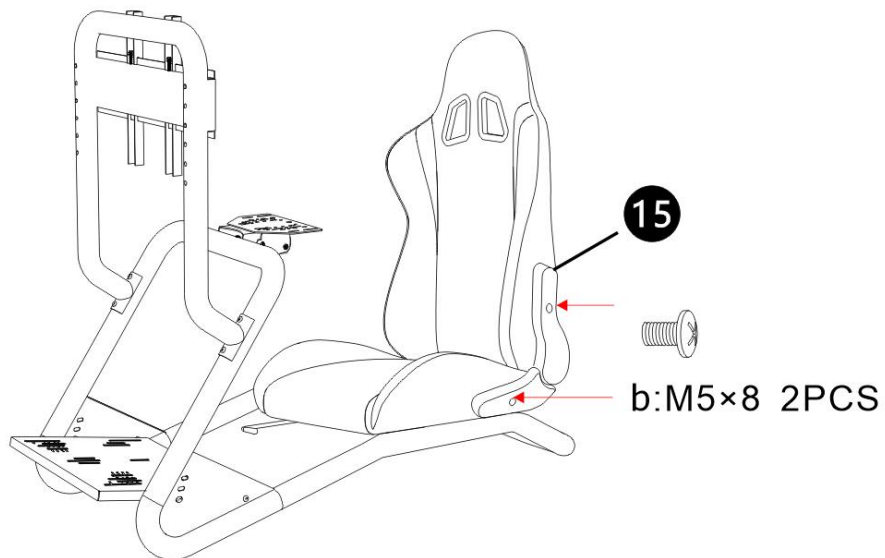

**STEP 14:**

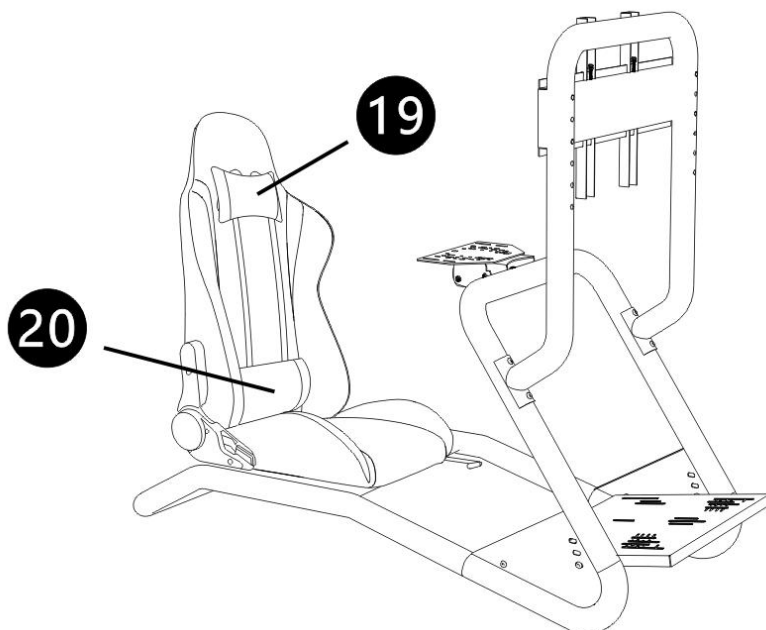

**STEP 15:**

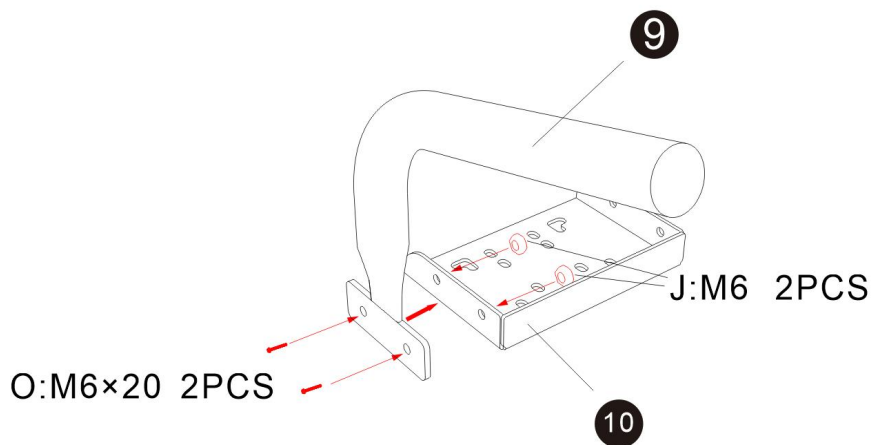

**STEP 16:**

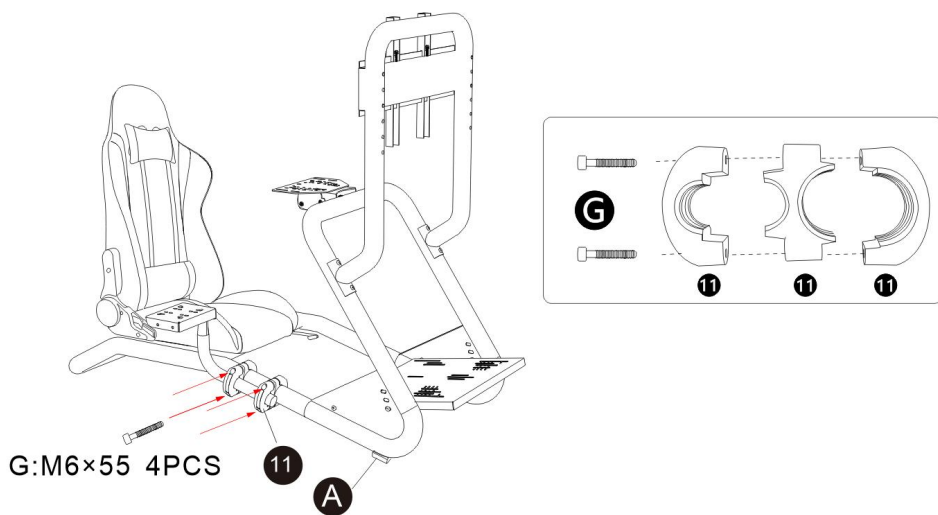

## Complete assembly

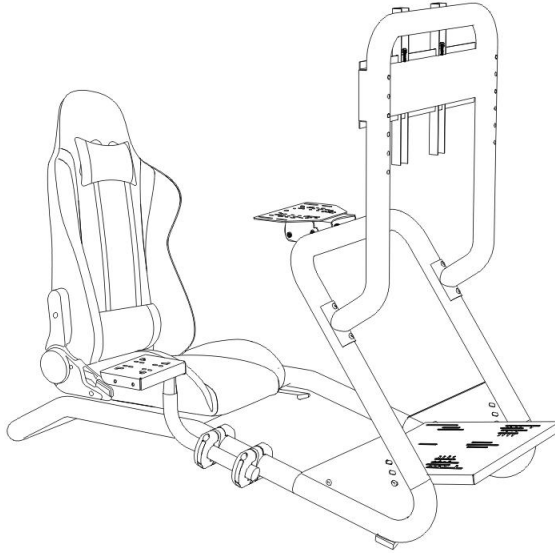

**Manufacturer:** Shanghaimuxinmuyeyouxiangongsi

**Address:** Shuangchenglu 803nong11hao1602A-1609shi, baoshanqu, shanghai 200000 CN.

**Imported to AUS:** SIHAO PTY LTD. 1 ROKEVA STREETEASTWOOD NSW 2122 Australia

**Imported to USA:** Sanven Technology Ltd. Suite 250, 9166 Anaheim Place, Rancho Cucamonga, CA 91730

<b>UK</b>	<b>REP</b>
-----------	------------

YH CONSULTING LIMITED. C/O YH Consulting Limited Office 147, Centurion House, London Road, Staines-upon-Thames, Surrey, TW18 4AX

<b>EC</b>	<b>REP</b>
-----------	------------

E-CrossStu GmbH  
Mainzer Landstr.69,  
60329 Frankfurt am Main.





# **VEVOR**

**Affordable. Reliable. Home Improvement.**

## **SUPPORT DE VOLANT**

**MODÈLE: 6013**



# VEVOR

Affordable. Reliable. Home Improvement.

## STEERING WHEEL STAND

Modèle : 6013



Ceci est le mode d'emploi d'origine. Veuillez lire attentivement l'intégralité du manuel avant utilisation. VEVOR se réserve le droit d'interpréter clairement ce manuel d'utilisation. L'apparence du produit dépend du produit que vous avez reçu. Veuillez nous excuser pour les éventuelles mises à jour technologiques ou logicielles.





Avertissement - Pour réduire le risque de blessure, l'utilisateur doit lire attentivement le manuel d'instructions.



## Attention

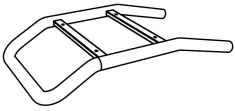
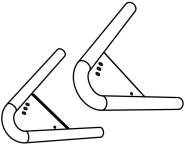
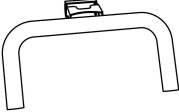
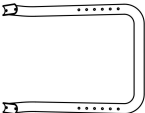

- Veuillez installer et utiliser le support conformément aux instructions .
- Veuillez installer modérément, évitez les fortes vibrations .
- Ne pas conserver dans des conditions humides, à des températures élevées ou dans un endroit poussiéreux .
- La structure du produit est flexible. Portez des gants de travail lors de l'assemblage. Attention aux mains blessées lors de l'installation.
- Les enfants doivent être sous la surveillance d'un adulte lorsqu'ils utilisent le produit.

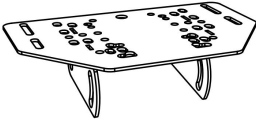
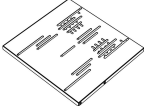
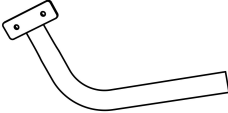
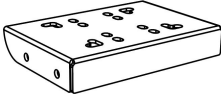
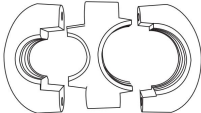
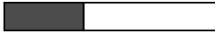

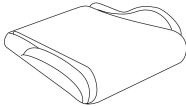
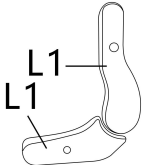
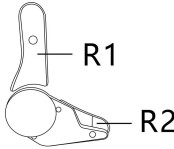
## Conservez le manuel.

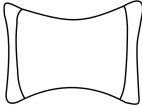

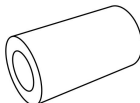
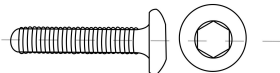
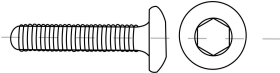
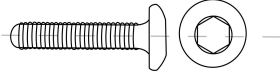
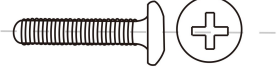
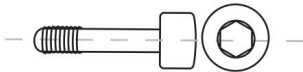
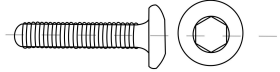

Liste des pièces			
Code	Image	Nom	Qté.
1		piédestal	1
2		Coude de raccordement en V	1
3		pièce en forme de U	1
4		Moniteur 6013 - Support en U	1

5		Moniteur 6013- Aube coulissante verticale	2
6		Moniteur 6013 - Plaque transversale en acier	1
7		Panneau de volant	1
8		Panneau de pédale	1
9		Support de levier de vitesses	1
10		Panneau de levier de vitesses	1
11		attaches en plastique	2
12		Sangle d'arrimage	6

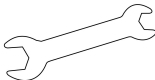
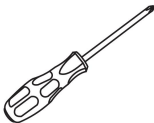
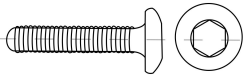
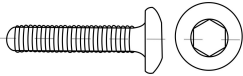
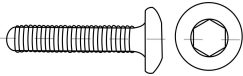
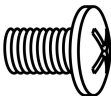
13		dos	1
14		siège	1
15		Cache plastique du dispositif de réglage d'angle - gauche	1
16		Cache plastique du dispositif de réglage d'angle - droit	1
17		fauteuil inclinable gauche	1
18		fauteuil inclinable à droite	1
19		Oreiller appui-tête	1

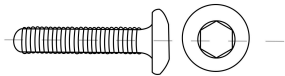
20		oreiller lombaire	1
UN		Coussin de support de tuyau	4
B		cylindre en plastique	4
C		Vis M 8x20	4+1
D		Vis M 8x45	4+1
E		Vis M 8x60	4+1
F		Vis M 5x30	2+1
G		Vis M 6x55	4+1
H		Vis M6 x 16	12

je		Écrou à bride M8	8+1
J		Écrou à bride M6	2+6
K		Clé hexagonale 5 mm	1
L		10-13 ouvert clé	1
M		Tournevis	1
N		Vis M6 × 30	4+1
O		Vis M6 × 20	6+1
un		Vis M 8×25	8+1
b		Vis M 5×8	6+1

d		Vis M 8×35	4+1
et		Rondelle élastique M8	8+1
f		Rondelle plate M8	4+1
g		Clé polygonale 5 mm	1

**Remarque :** 12 vis M6\*16 et 6 écrous M6 sont gratuits.

★ Pour la liste des kits de siège et l'installation, veuillez vous référer au manuel de procédure d'installation du siège en pièce jointe.

### ÉTAPE 1 :

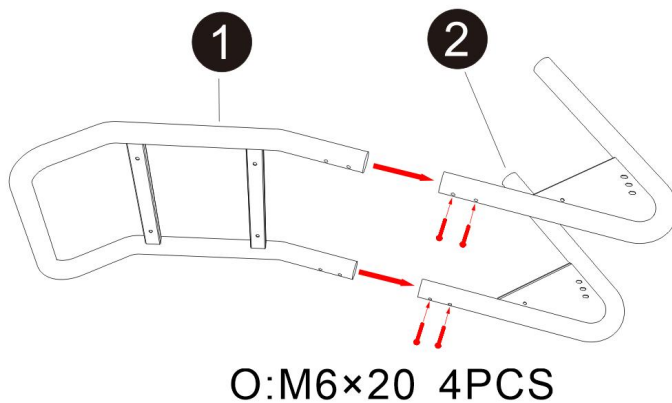

## ÉTAPE 2 :

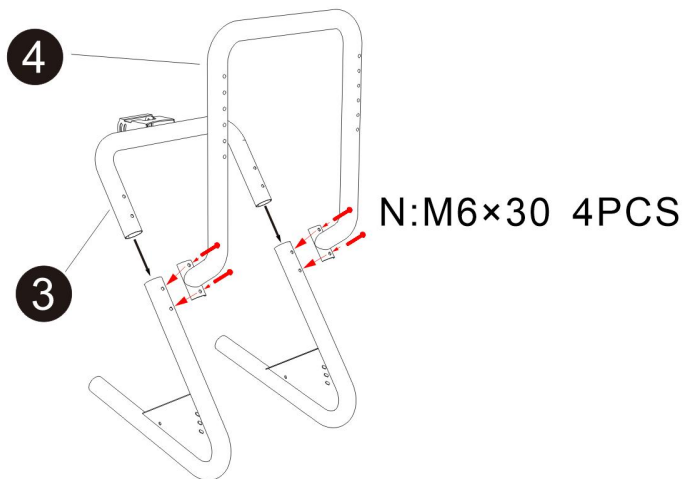

## ÉTAPE 3 :

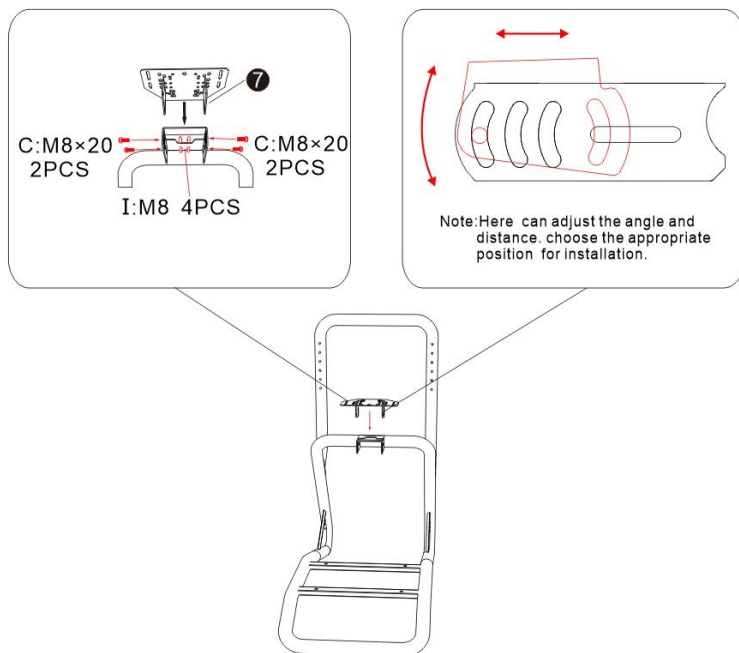

## ÉTAPE 4 :

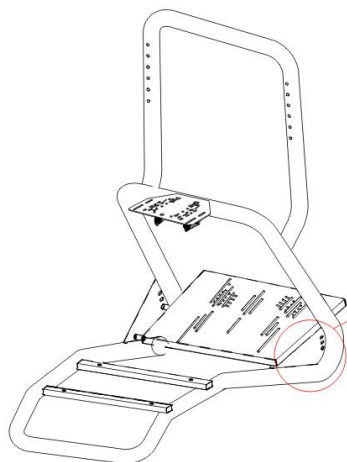

Note: There are 3 adjustable angles available. choose the appropriate angle for installation.

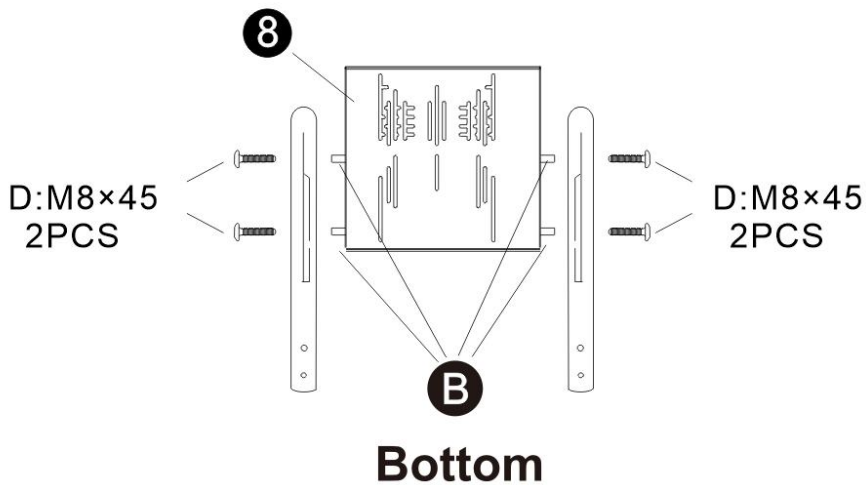
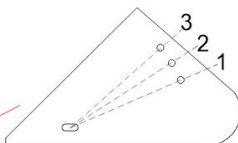

**ÉTAPE 5 :**

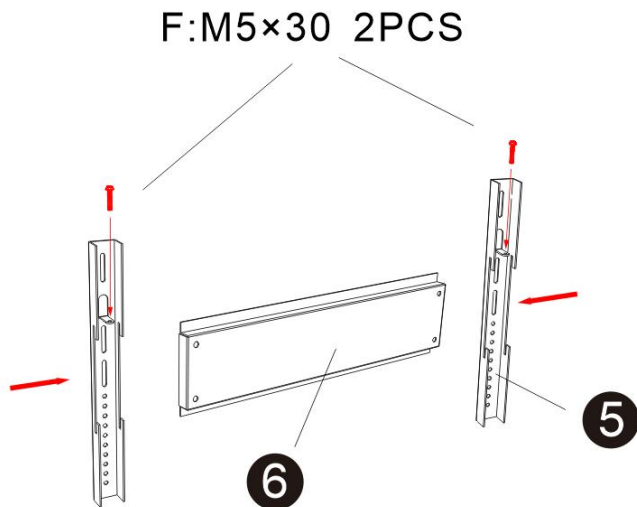

**ÉTAPE 6 :**

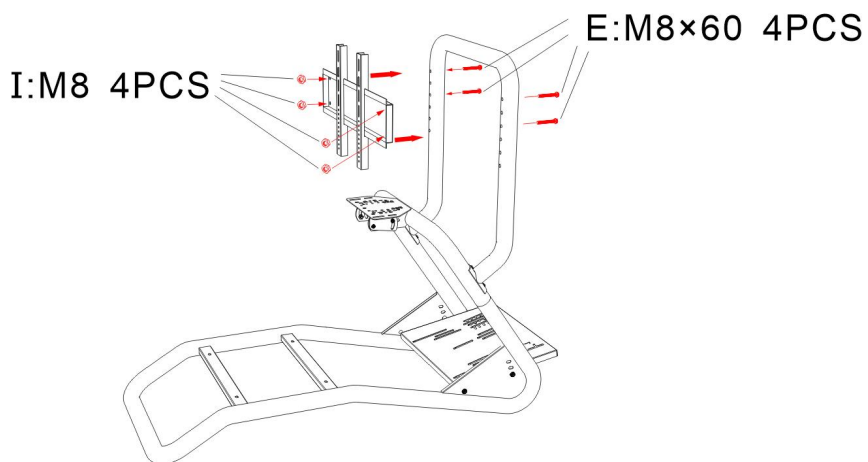

## ÉTAPE 7 :

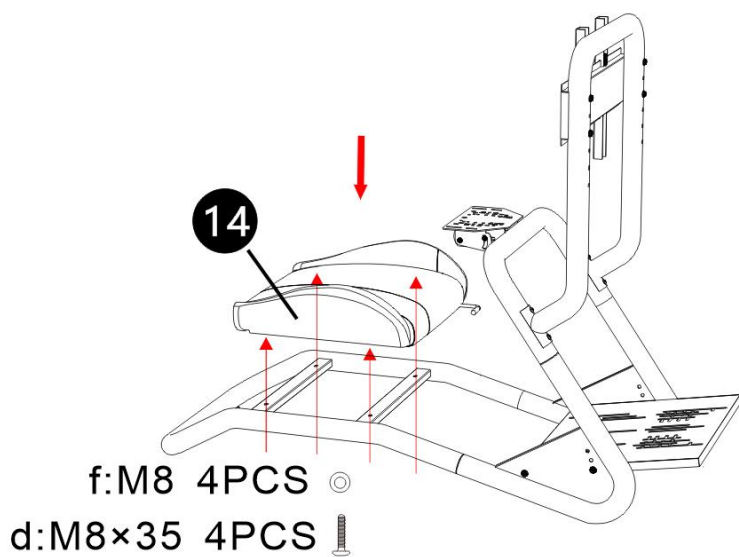

## ÉTAPE 8 :

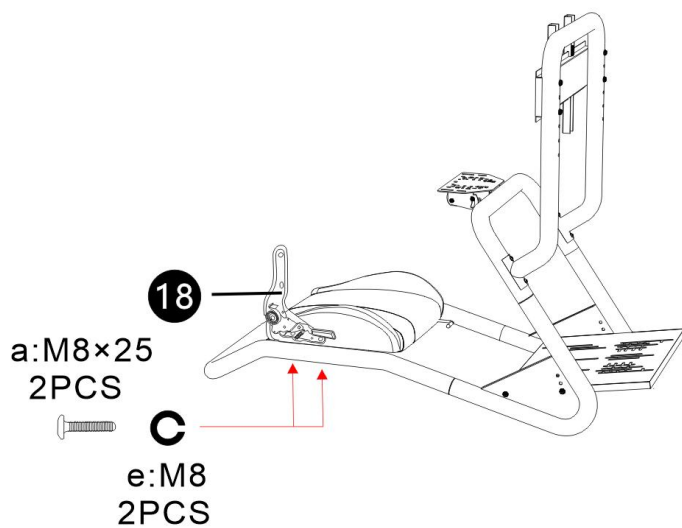

## ÉTAPE 9 :

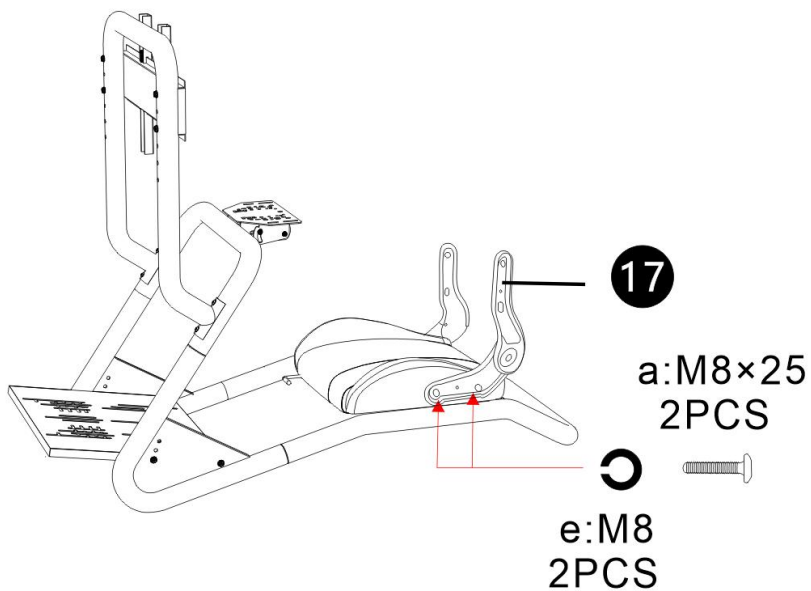

## ÉTAPE 10 :

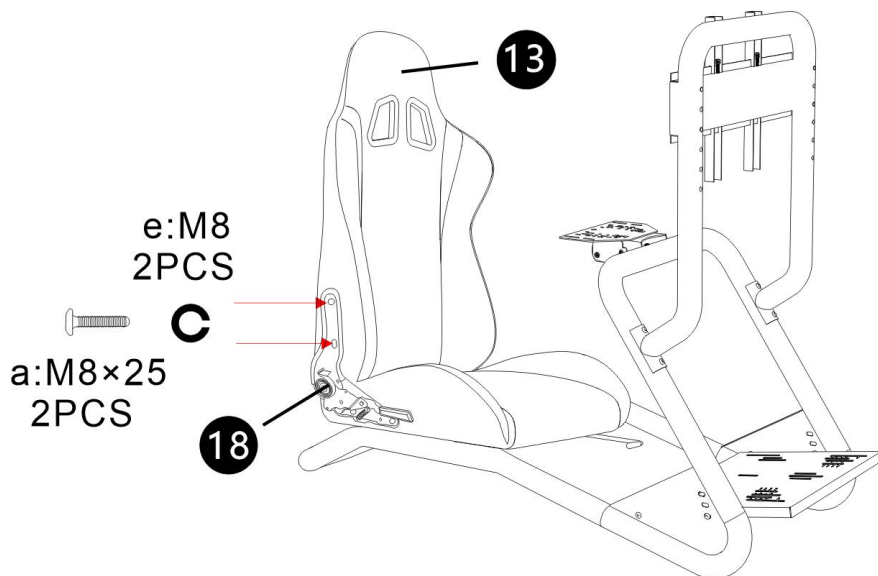

## ÉTAPE 1 1 :

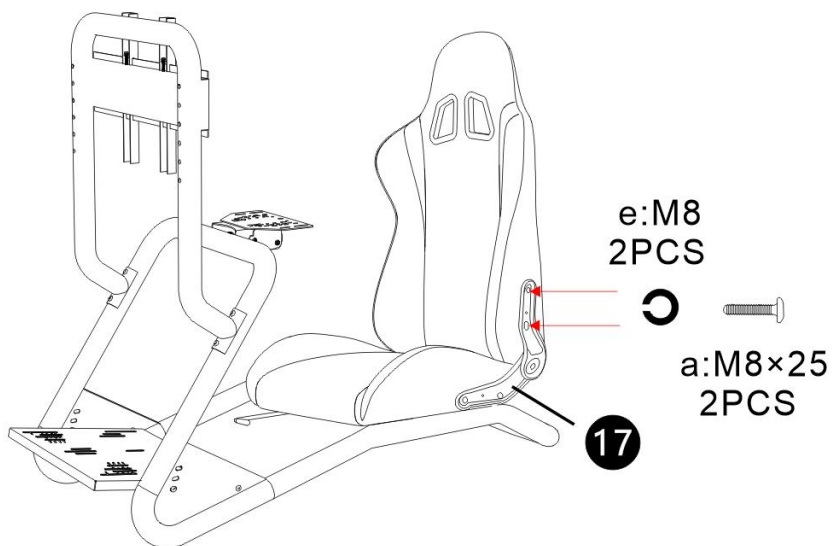

## ÉTAPE 1 2 :

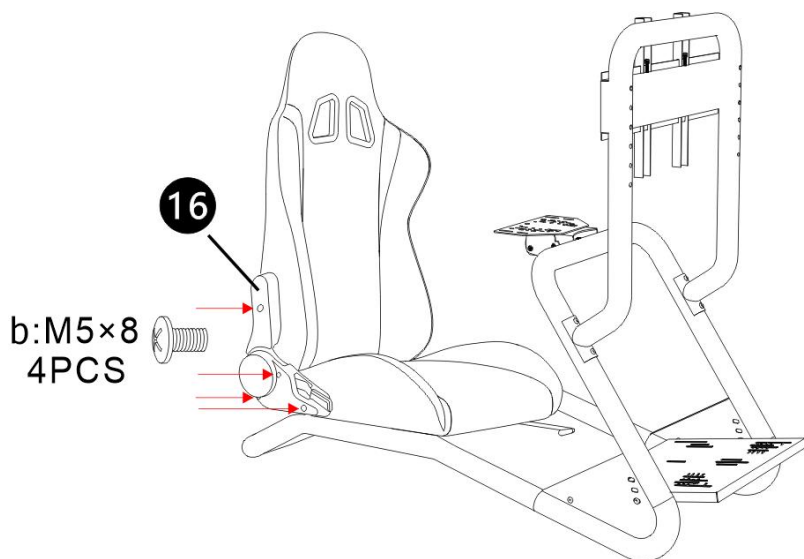

### ÉTAPE 13 :

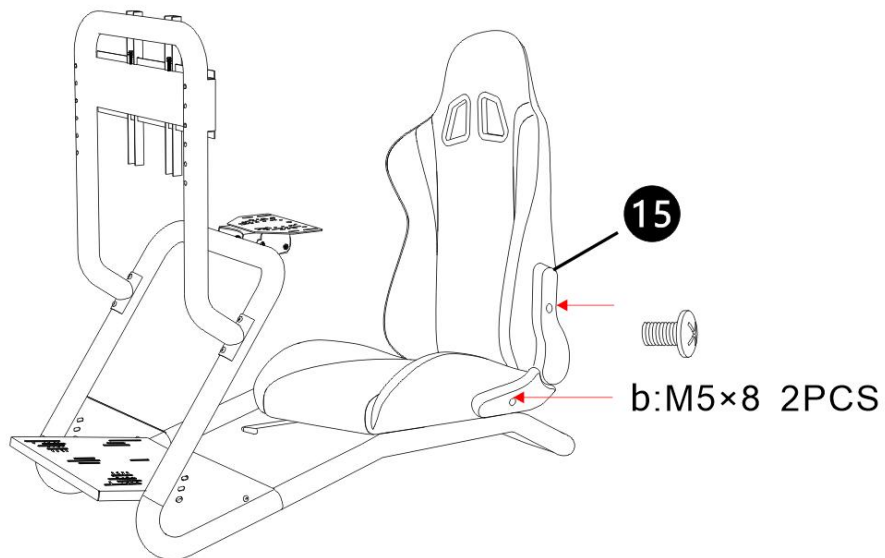

### ÉTAPE 14 :

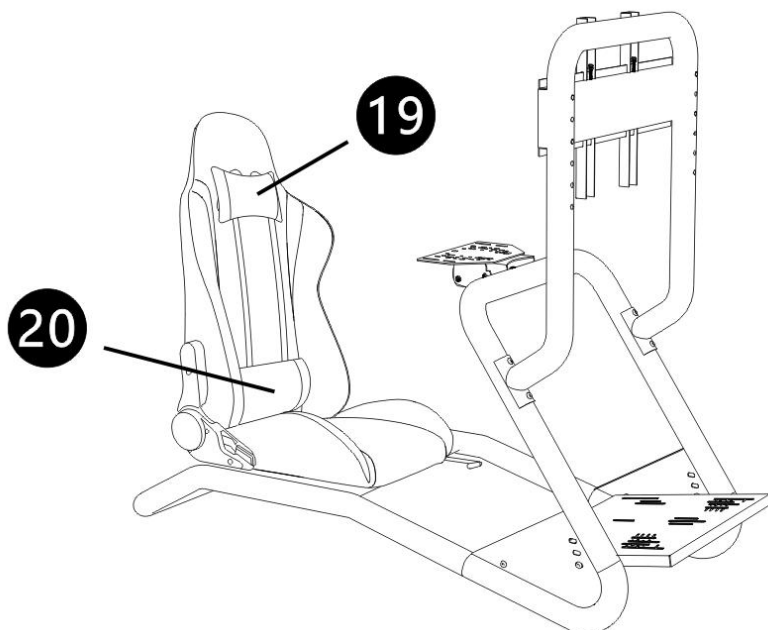

## ÉTAPE 15 :

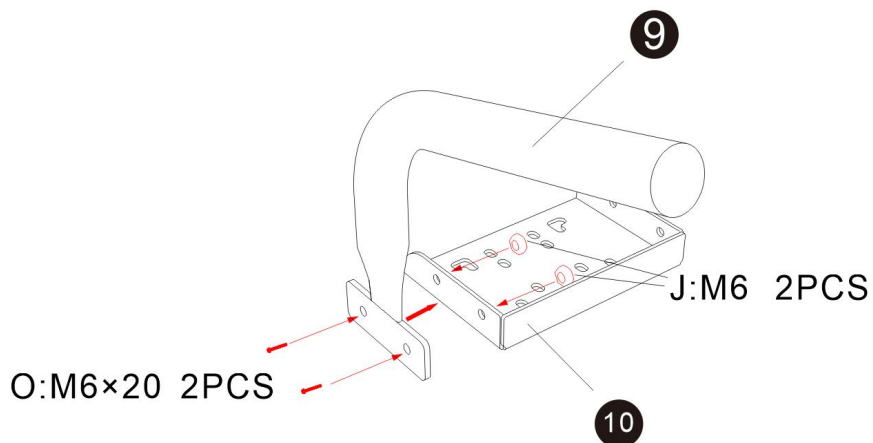

## ÉTAPE 16 :

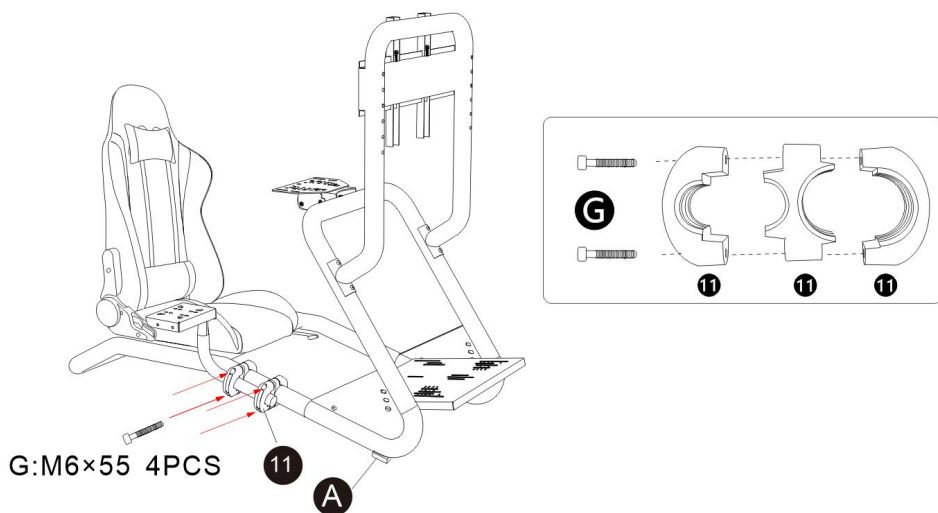

## Assemblage complet



**Fabricant :** Shanghaimuxinmuyeyouxiangongsi

**Adresse :** Shuangchenglu 803nong11hao1602A-1609shi, baoshanqu, Shanghai 200 000 CN.

**Importé en Australie :** SIHAO PTY LTD. 1 ROKEVA STREET, ASTWOOD NSW 2122 Australie

**Importé aux États-Unis :** Sanven Technology Ltd. Suite 250, 9166 Anaheim

Lieu, Rancho Cucamonga, CA 91730

<b>UK</b>	<b>REP</b>
-----------	------------

YH CONSULTING LIMITED. C/O YH Consulting Limited Office 147, Centurion House, London Road, Staines-upon-Thames, Surrey, TW18 4AX

<b>EC</b>	<b>REP</b>
-----------	------------

E-CrossStu GmbH  
Mainzer Landstr.69,  
60329 Frankfurt am Main.





# VEVOR

**Affordable. Reliable. Home Improvement.**

## LENKRADSTÄNDER

MODELL: 6013



# VEVOR

Affordable. Reliable. Home Improvement.

## STEERING WHEEL STAND

**Modell: 6013**



Dies ist die Originalanleitung. Bitte lesen Sie alle Anweisungen sorgfältig durch, bevor Sie das Gerät in Betrieb nehmen. VEVOR behält sich eine klare Auslegung unserer Bedienungsanleitung vor. Das Aussehen des Produkts hängt vom gelieferten Produkt ab. Bitte haben Sie Verständnis dafür, dass wir Sie nicht erneut über Technologie- oder Software-Updates informieren.



Warnung: Um das Verletzungsrisiko zu verringern, muss der Benutzer die Bedienungsanleitung sorgfältig lesen.





## Aufmerksamkeiten

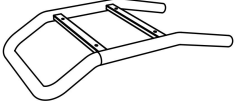
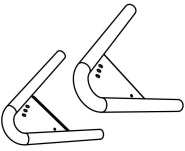
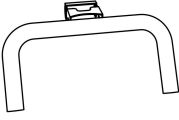

- Bitte installieren und verwenden Sie den Ständer gemäß der Anleitung .
- Bitte maßvoll installieren, starke Vibrationen vermeiden .
- Nicht in feuchter Umgebung, bei hohen Temperaturen oder an einem staubigen Ort aufbewahren .
- Die Produktstruktur ist flexibel. Tragen Sie bei der Montage Arbeitshandschuhe. Achten Sie bei der Installation darauf, dass Ihre Hände nicht verletzen.
- Kinder sollten bei der Verwendung des Produkts unter Aufsicht von Erwachsenen stehen.

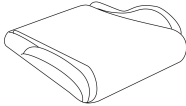
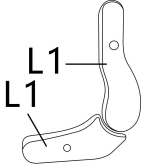
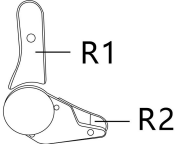

**Bewahren Sie das Handbuch auf.**

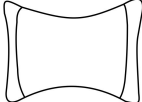

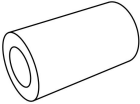
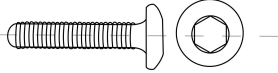
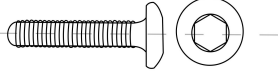
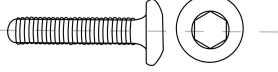
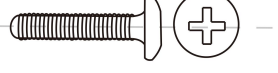
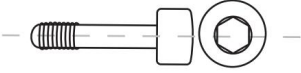
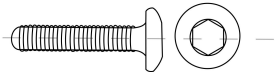

<b>Teilleiste</b>			
<b>Code</b>	<b>Bild</b>	<b>Name</b>	<b>MENGE.</b>
1		Sockel	1
2		V-förmiger Anschlussbogen	1
3		U-förmiges Teil	1

4		6013 Monitor - U-förmige Halterung	1
5		6013 Monitor- Vertikalschieber	2
6		6013 Monitor -Querstrebe Stahlplatte	1
7		Lenkradverkleidung	1
8		Pedalplatte	1
9		Schalthebelhalter	1
10		Schalthebelverkleidung	1
11		Kunststoffverschlüsse	2

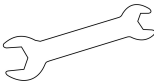
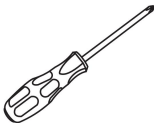
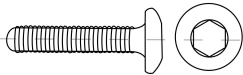
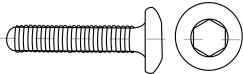
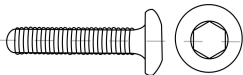
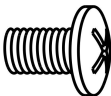
12		Zurrgurt	6
13		zurück	1
14		Sitz	1
15		Winkerversteller Kunststoffabdeckung - links	1
16		Winkerversteller Kunststoffabdeckung - rechts	1
17		Liegestuhl links	1
18		Liegestuhl-rechts	1
19		Kopfstützenkissen	1

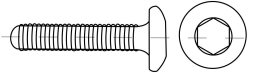
20		Lendenkissen	1
A		Rohrstützpolster	4
B		Kunststoffzylinder	4
C		Schraube M 8x20	4+1
D		Schraube M 8x45	4+1
E		Schraube M 8x60	4+1
F		Schraube M 5x30	2+1
G		Schraube M 6x55	4+1
H		Schraube M6 x16	12

ICH		Flanschmutter M8	8+1
J		Flanschmutter M6	2+6
K		Sechskantschlüssel 5mm	1
L		10-13 offenes Ende Schlüssel	1
M		Schraubendreher	1
N		Schraube M6 x30	4+1
O		Schraube M6 x20	6+1
A		Schraube M 8x25	8+1
B		Schraube M 5x8	6+1

D		Schraube M 8×35	4+1
e		Federscheibe M8	8+1
F		Unterlegscheibe M8	4+1
G		Ringschlüssel 5mm	1

**Hinweis:** 12 Schrauben M6\*16 und 6 Muttern M6 sind im Lieferumfang enthalten.

★ Eine Liste der Sitzbausätze und der Installation finden Sie im Anhang des Handbuchs zur Sitzinstallation.

**SCHRITT 1 :**

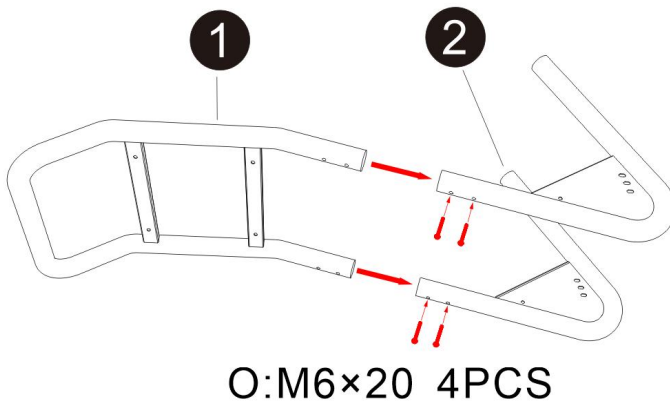

## SCHRITT 2:

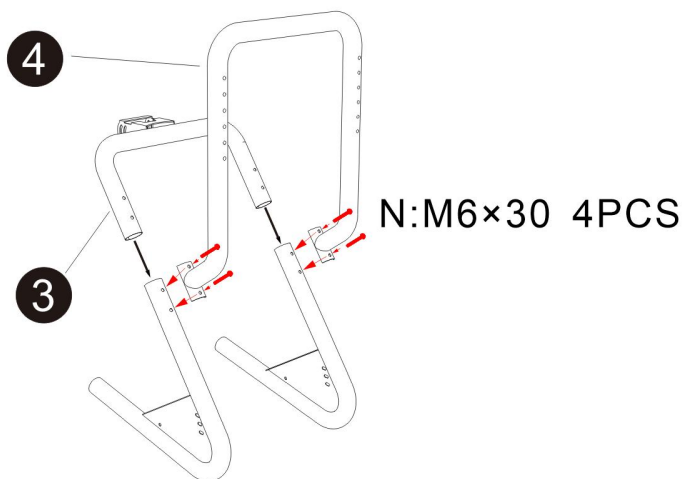

## SCHRITT 3:

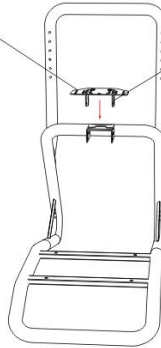
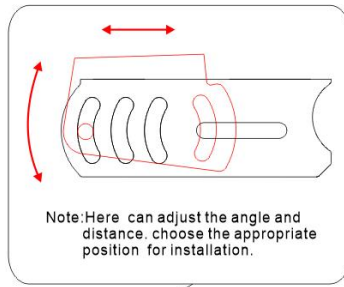
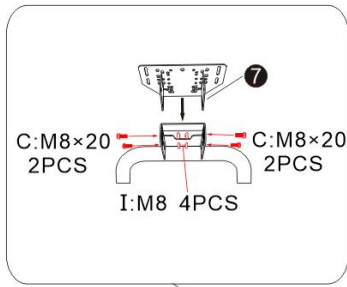

#### SCHRITT 4:

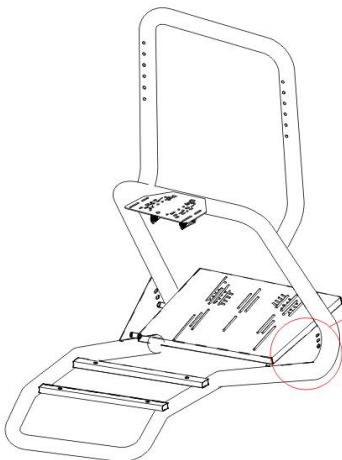

Note: There are 3 adjustable angles available. choose the appropriate angle for installation.

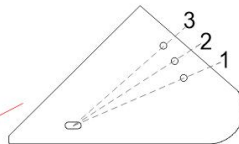

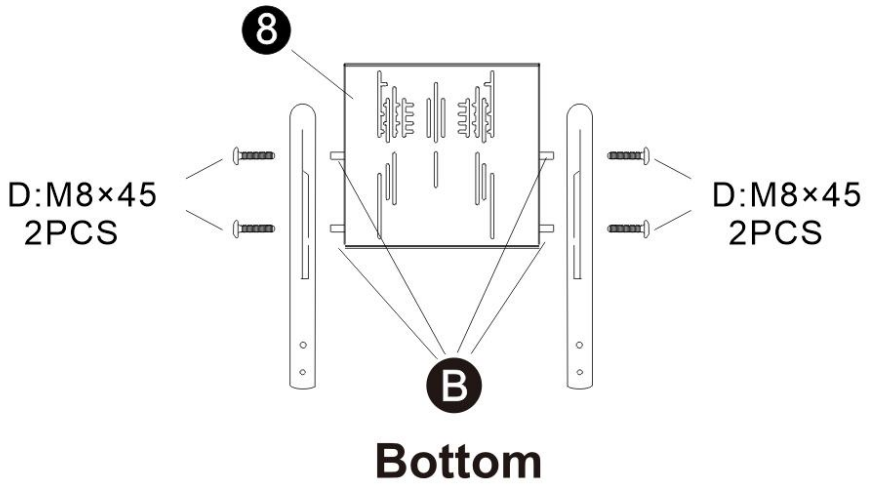

**SCHRITT 5:**

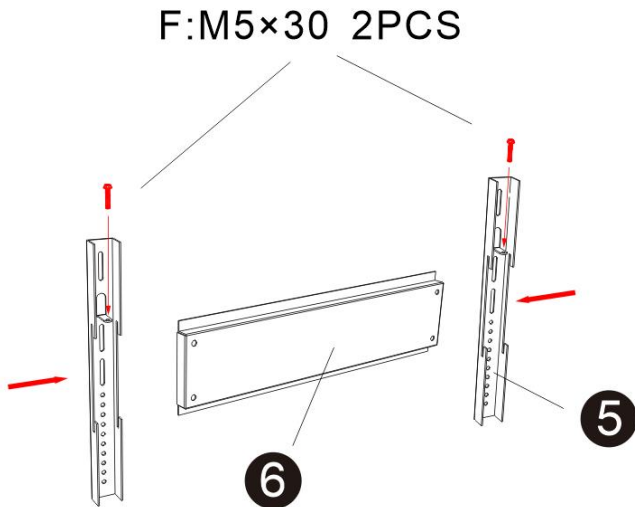

## SCHRITT 6:

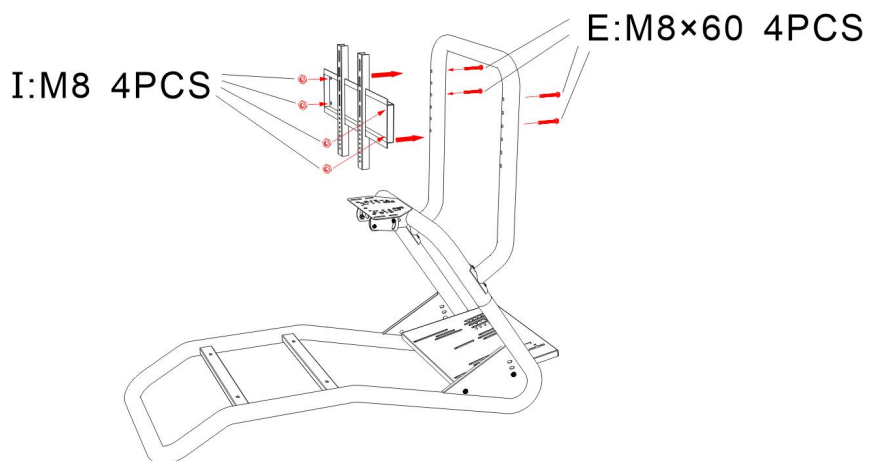

## SCHRITT 7:

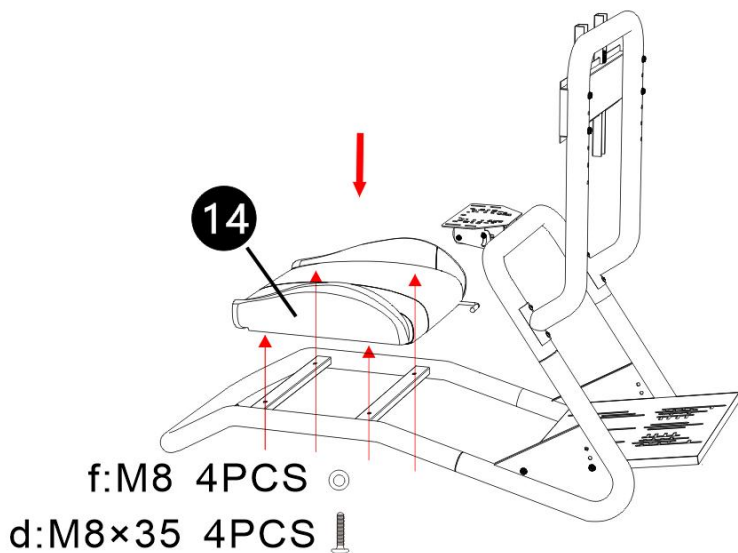

## SCHRITT 8:

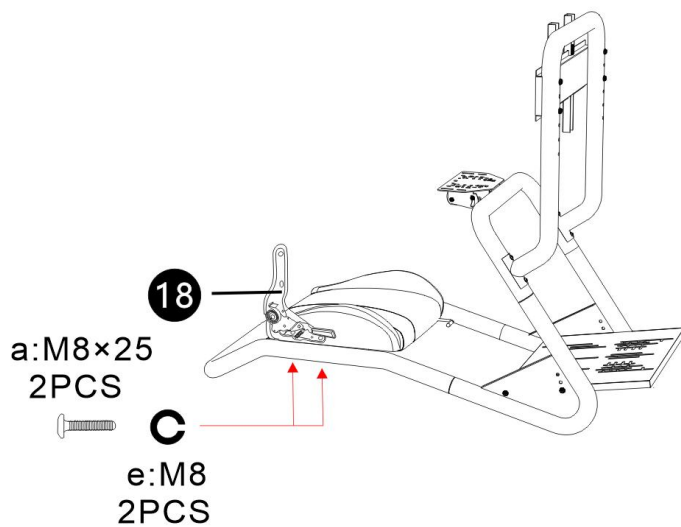

## SCHRITT 9:

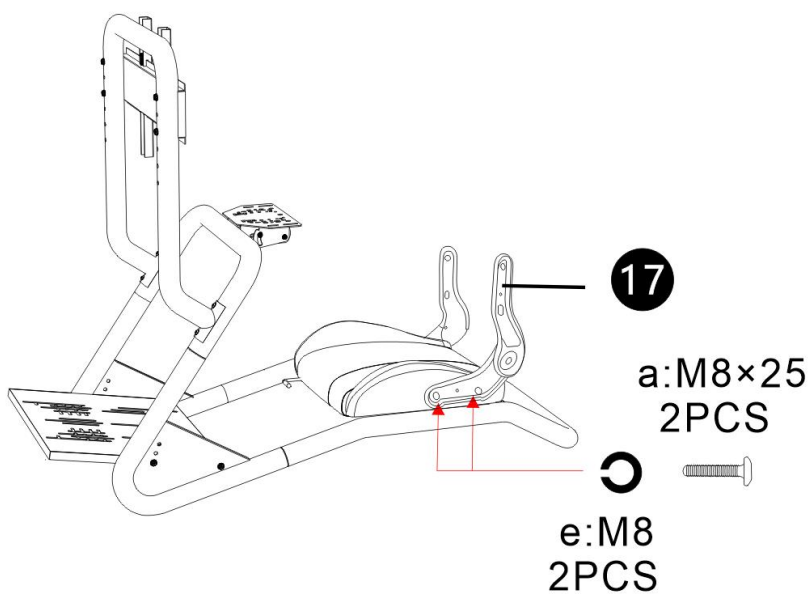

## SCHRITT 1 0:

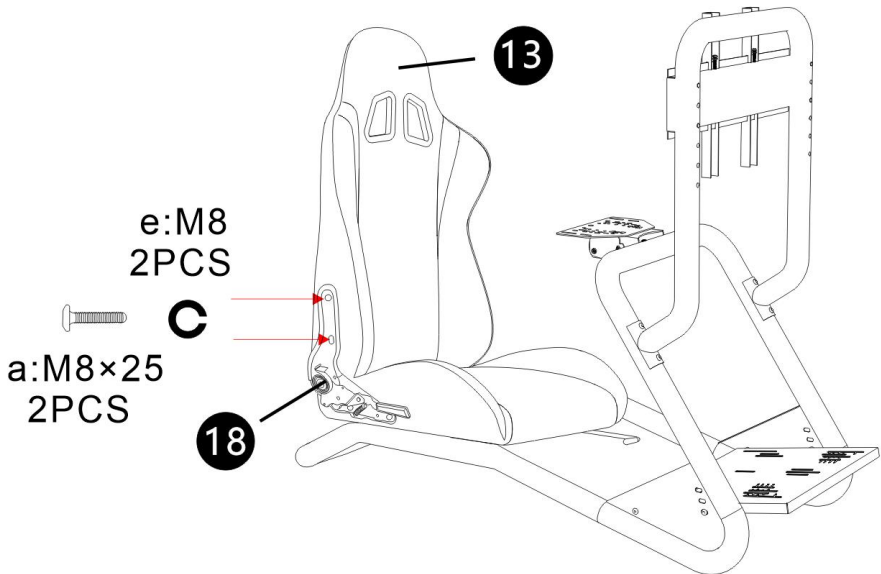

## SCHRITT 1 1:

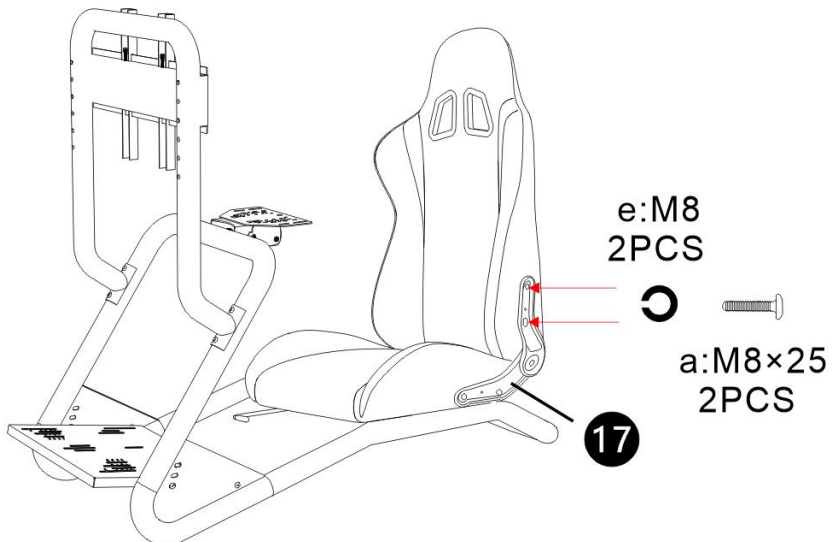

## SCHRITT 1 2:

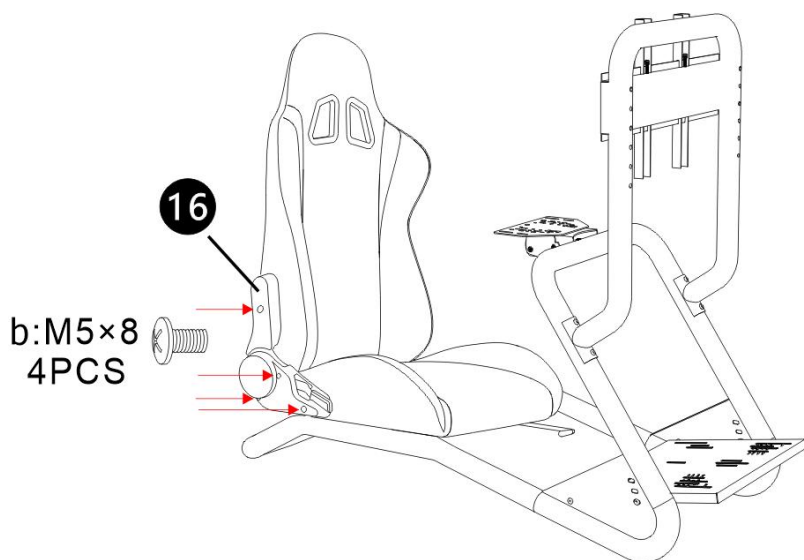

## SCHRITT 1 3:

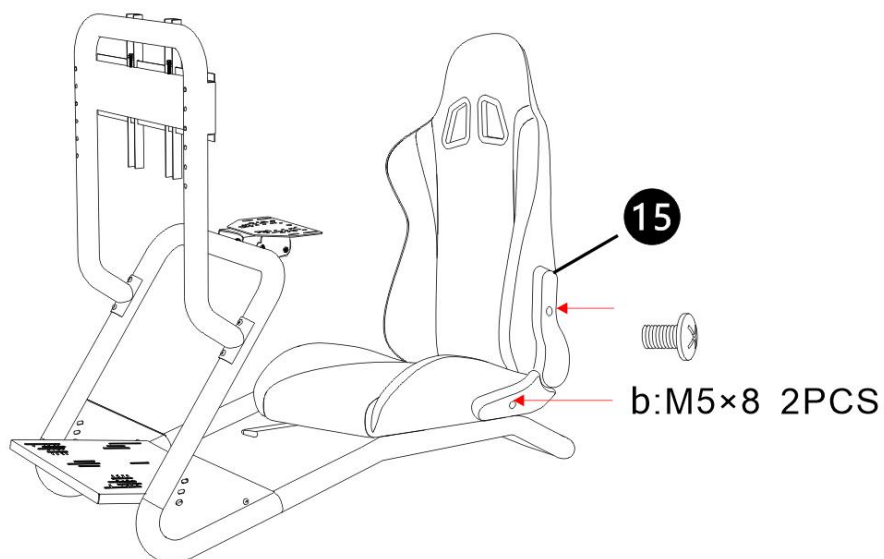

## SCHRITT 14:

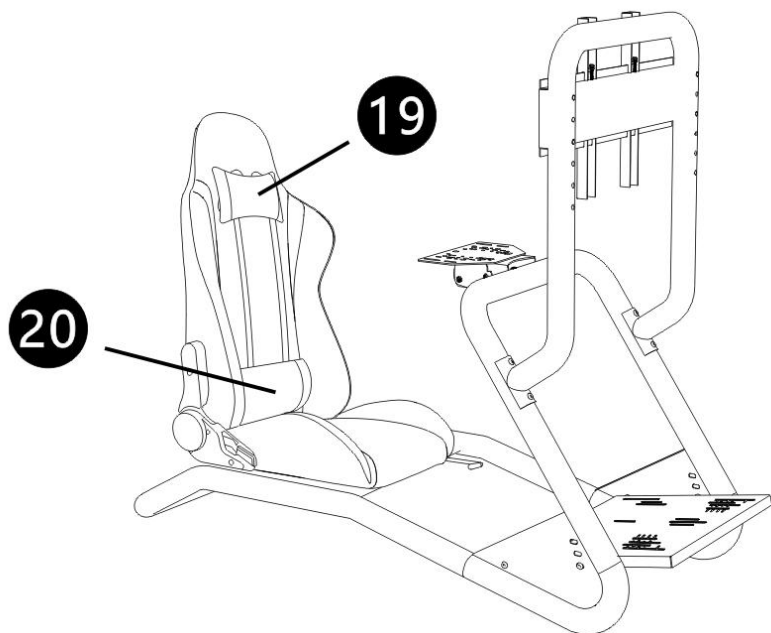

## SCHRITT 15:

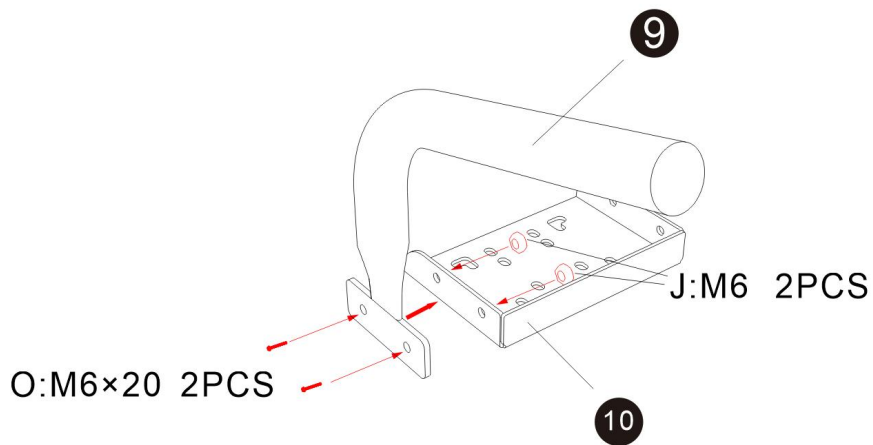

## SCHRITT 16:

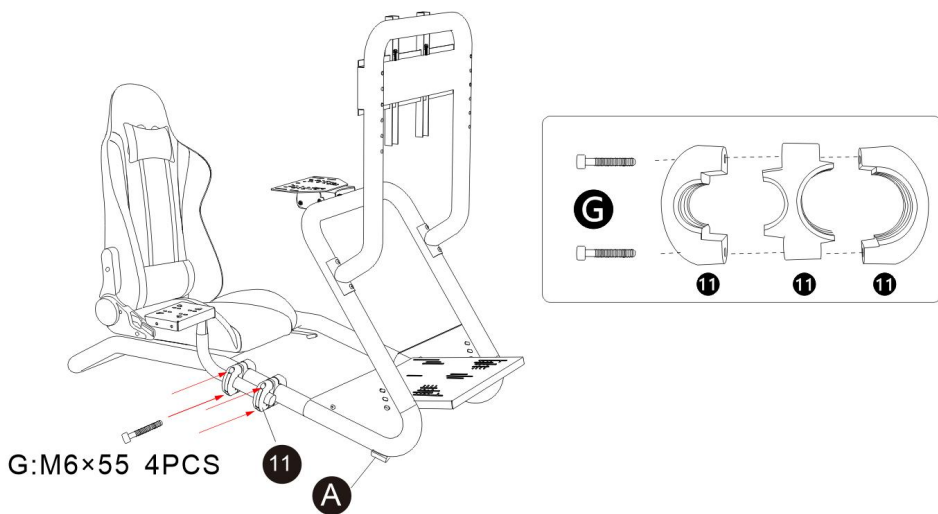

## Komplettmontage



**Hersteller:** Shanghai muxinmuyeyouxiangongsi

**Adresse:** Shuangchenglu 803nong11hao1602A-1609shi, baoshanqu, Shanghai 200000 CN.

**Importiert nach AUS:** SIHAO PTY LTD. 1 ROKEVA STREETEASTWOOD NSW 2122 Australien

**Importiert in die USA:** Sanven Technology Ltd. Suite 250, 9166 Anaheim Place, Rancho Cucamonga, CA 91730

<b>UK</b>	<b>REP</b>
-----------	------------

YH CONSULTING LIMITED. C/O YH Consulting Limited Office 147, Centurion House, London Road, Staines-upon-Thames, Surrey, TW18 4AX

<b>EC</b>	<b>REP</b>
-----------	------------

E-CrossStu GmbH  
Mainzer Landstr.69,  
60329 Frankfurt am Main.





# **VEVOR**

**Affordable. Reliable. Home Improvement.**

**SUPPORTO PER VOLANTE**

**MODELLO: 6013**



# VEVOR

Affordable. Reliable. Home Improvement.

## STEERING WHEEL STAND

**Modello: 6013**



Queste sono le istruzioni originali, si prega di leggere attentamente tutte le istruzioni del manuale prima dell'uso. VEVOR si riserva la piena interpretazione del proprio manuale utente. L'aspetto del prodotto dipenderà dal prodotto ricevuto. Vi preghiamo di scusarci se non vi informeremo più in caso di aggiornamenti tecnologici o software sul nostro prodotto.







Avvertenza: per ridurre il rischio di lesioni, l'utente deve leggere attentamente il manuale di istruzioni.

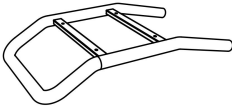
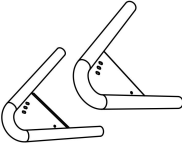
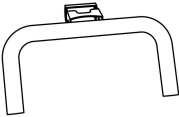

## Attenzioni

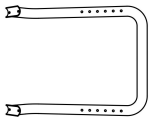

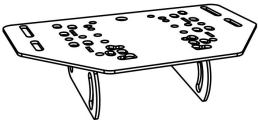
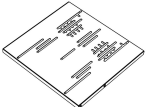
- Installare e utilizzare il supporto seguendo le istruzioni .
- Si prega di installare con moderazione, evitando forti vibrazioni .
- Non conservare in condizioni di umidità, temperature elevate o luoghi polverosi .
- La struttura del prodotto è flessibile, indossare guanti da lavoro durante il montaggio. Fare attenzione a non farsi male alle mani durante l'installazione.
- I bambini devono utilizzare il prodotto sotto la supervisione di un adulto.

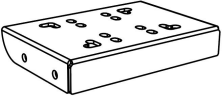

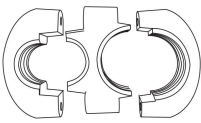
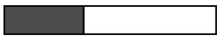

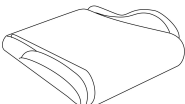
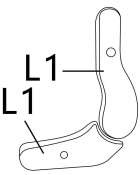
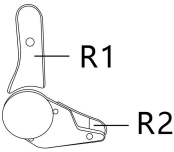
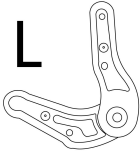
## Salva il manuale.

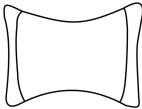

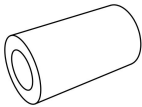
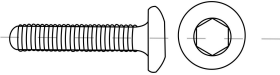
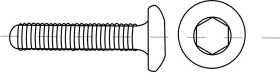
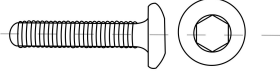
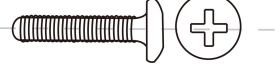

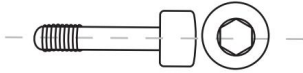
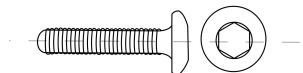

Elenco delle parti			
Codice	Immagine	Nome	QUANTITÀ
1		pedistallo	1
2		Gomito di collegamento a V	1
3		Parte a forma di U	1

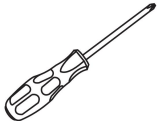
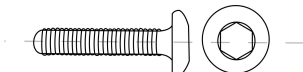
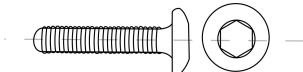
4		Monitor 6013 - Staffa a U	1
5		6013 monitor- Paletta scorrevole verticale	2
6		Monitor 6013 - Piastra in acciaio traversa	1
7		Pannello del volante	1
8		Pannello dei pedali	1
9		Supporto leva cambio	1
10		Pannello della leva del cambio	1

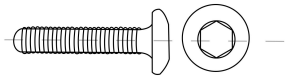
11		elementi di fissaggio in plastica	2
12		Cinghia di ancoraggio	6
13		Indietro	1
14		posto a sedere	1
15		Coperchio in plastica del regolatore dell'angolo - sinistro	1
16		Coperchio in plastica del regolatore dell'angolo - destro	1
17		poltrona reclinabile sinistra	1

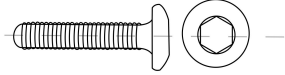
18	 R	poltrona reclinabile destra	1
19		Cuscino poggiatesta	1
20		Cuscino lombare	1
UN		Supporto per tubi	4
B		Cilindro di plastica	4
C		Vite M 8×20	4+1
D		Vite M 8×45	4+1
E		Vite M 8×60	4+1
F		Vite M 5×30	2+1

G		Vite M 6×55	4+1
H		Vite M6 ×16	12
IO		Dado flangiato M8	8+1
J		Dado flangiato M6	2+6
K		Chiave esagonale da 5 mm	1
L		10-13 aperto chiave inglese	1
M		Cacciavite	1
N		Vite M6 ×30	4+1
O		Vite M6 ×20	6+1

UN		Vite M 8×25	8+1
B		Vite M 5×8	6+1
D		Vite M 8×35	4+1
e		Rondella elastica M8	8+1
F		Rondella piana M8	4+1
G		Chiave ad anello da 5 mm	1

**Nota:** 12 viti M6\*16 e 6 dadi M6 sono gratuiti.

★ Per l'elenco dei kit di sedili e l'installazione, fare riferimento al manuale di istruzioni per l'installazione dei sedili allegato.

**PASSO 1 :**

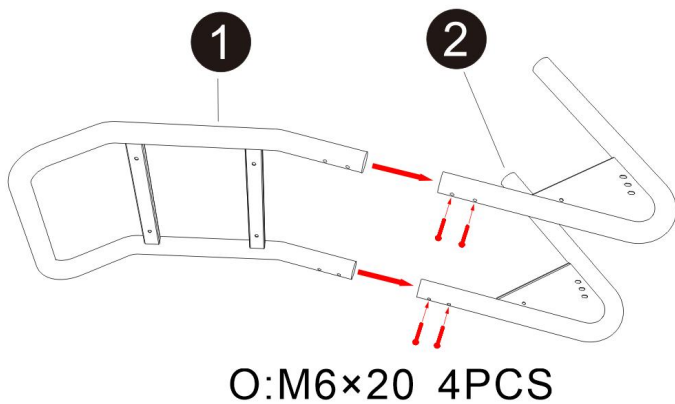

**PASSO 2:**

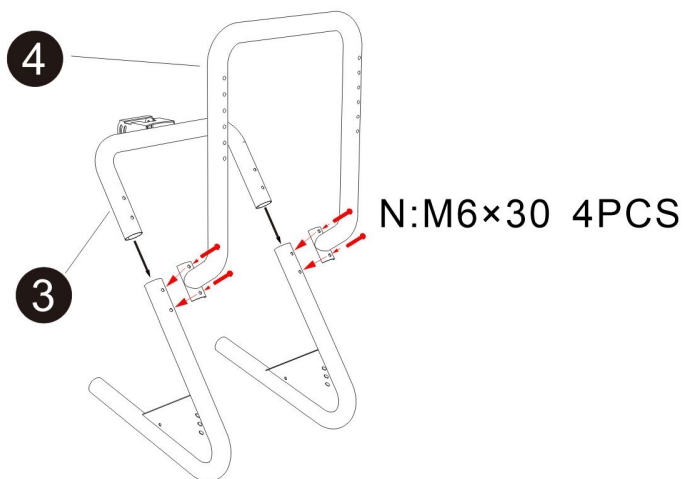

**PASSO 3:**

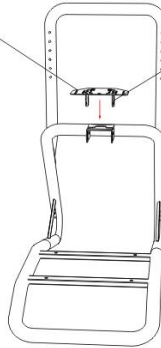
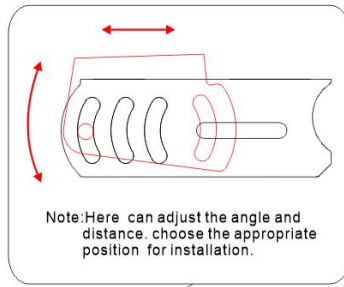
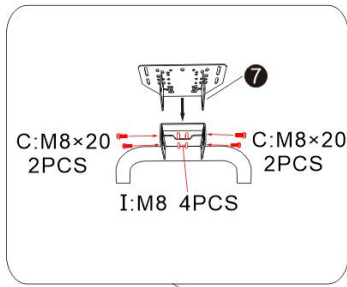

**PASSO 4:**

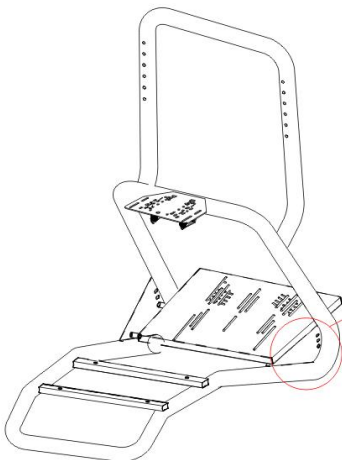

Note: There are 3 adjustable angles available. choose the appropriate angle for installation.

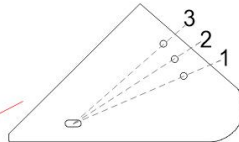

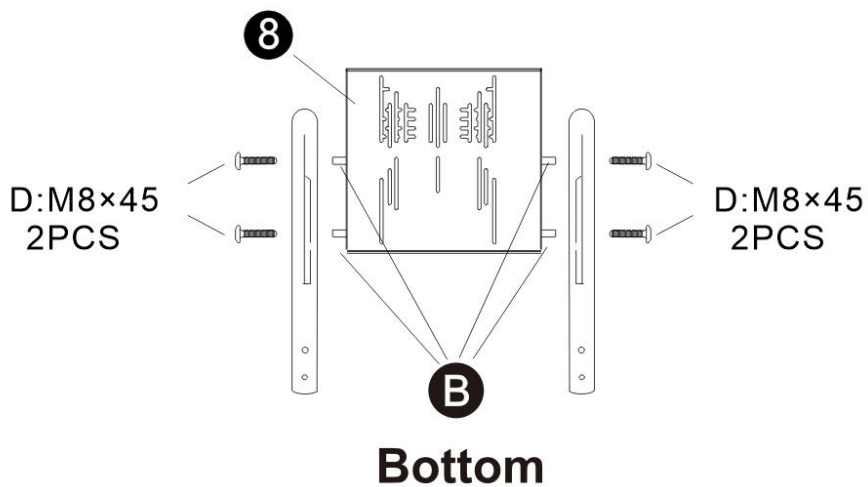

**PASSO 5:**

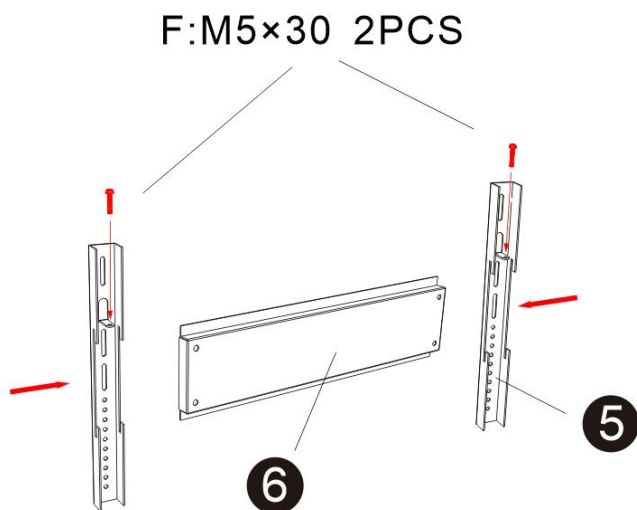

**PASSO 6:**

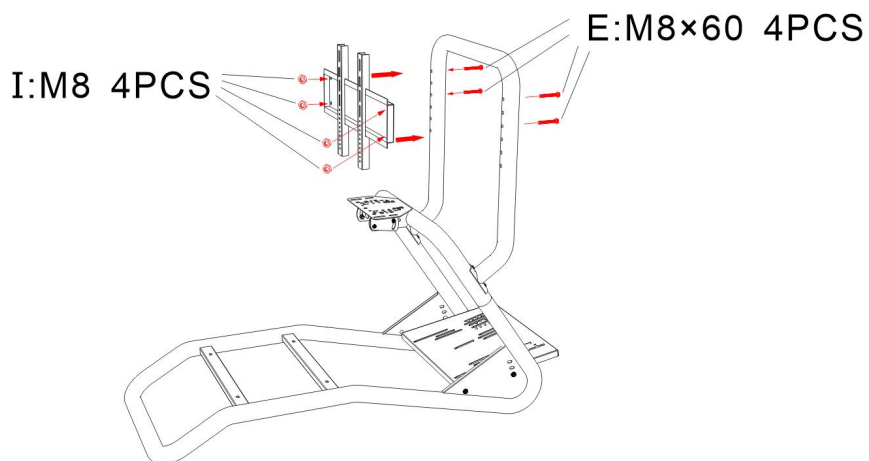

**PASSO 7:**

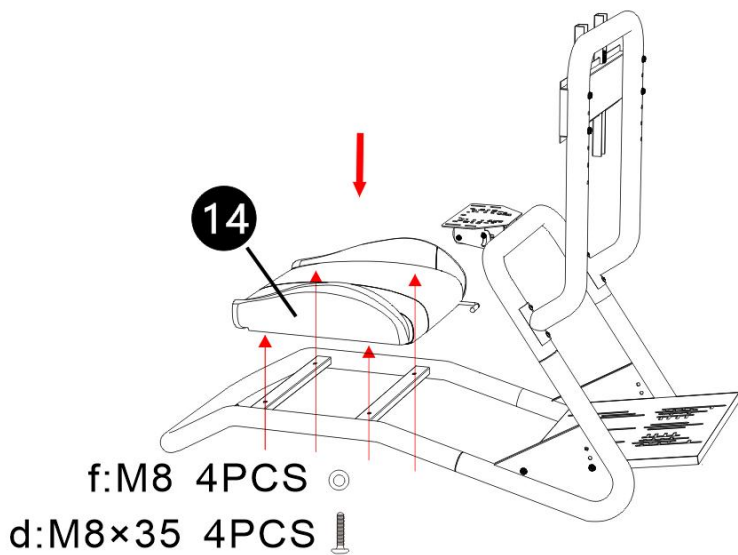

## PASSO 8:

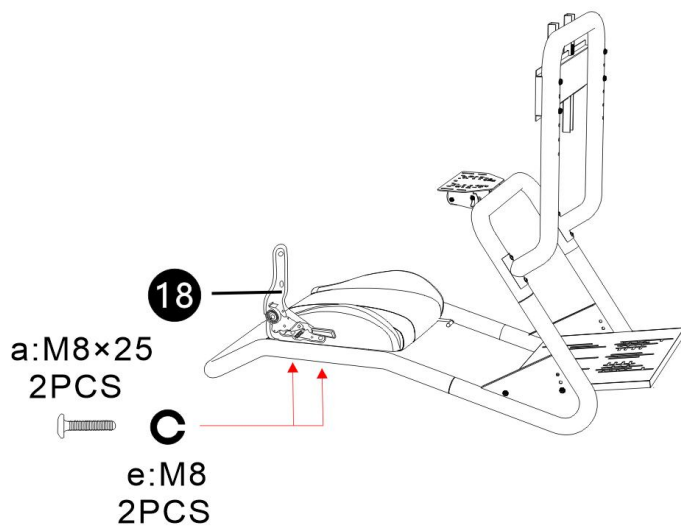

## PASSO 9:

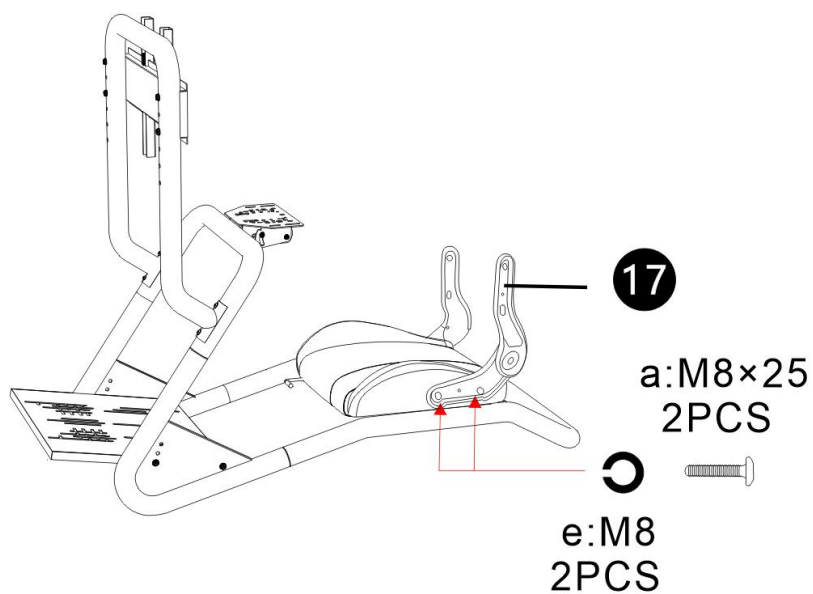

## PASSO 1 0:

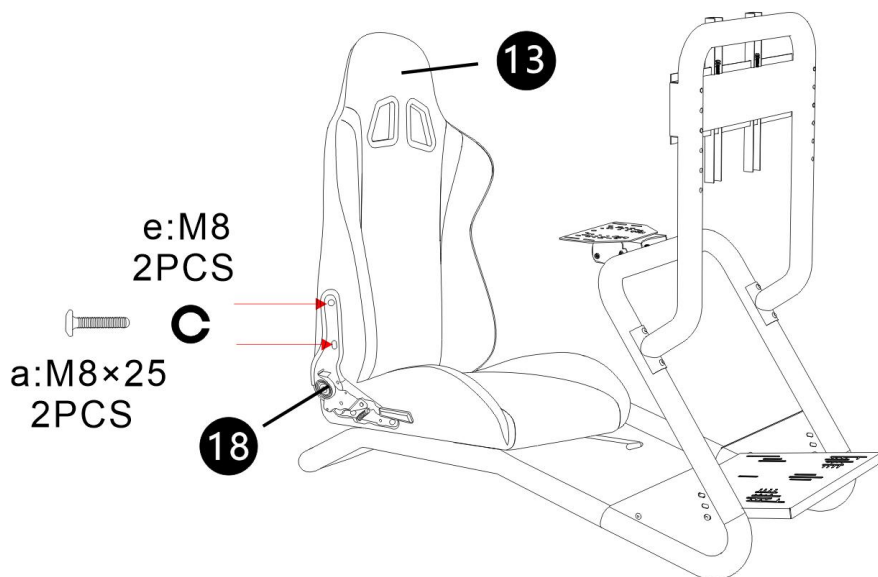

## PASSO 1 1:

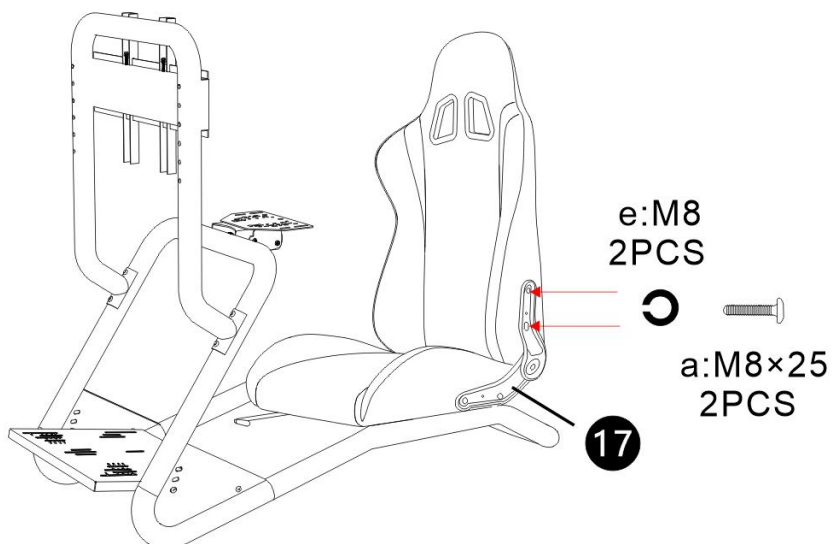

## PASSO 1 2:

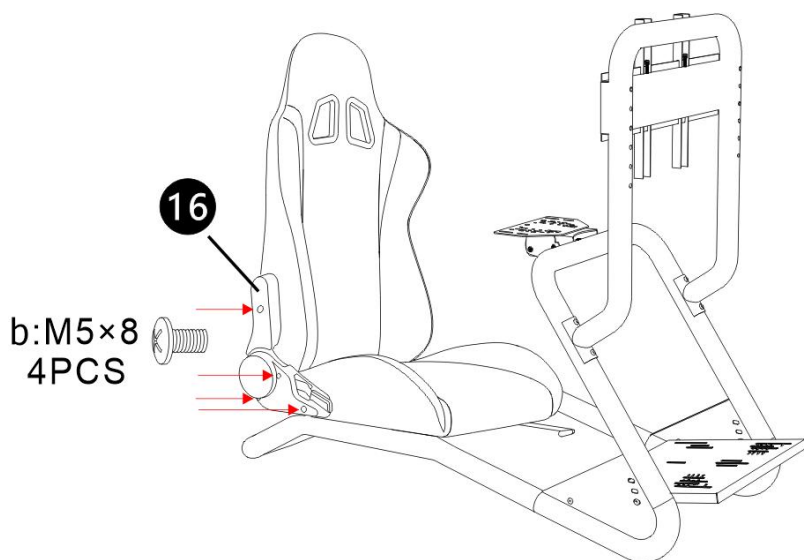

## PASSO 1 3:

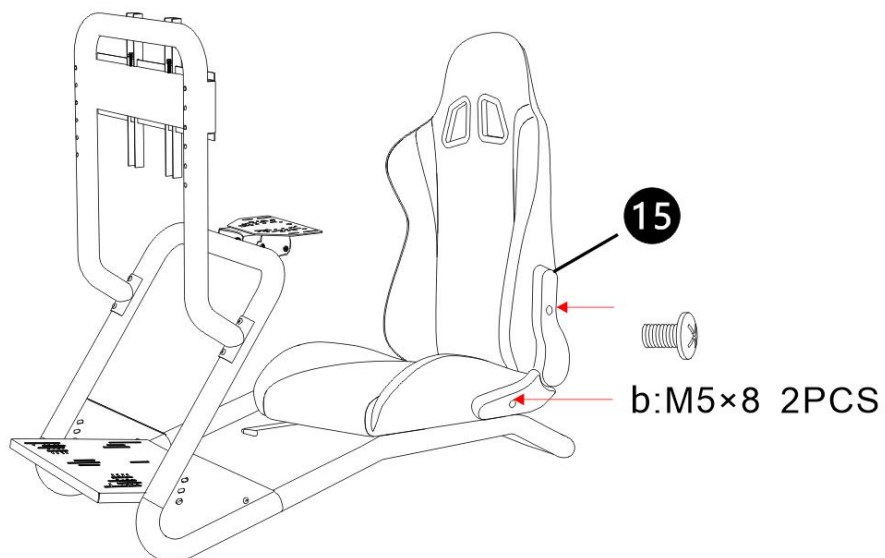

**PASSO 14:**

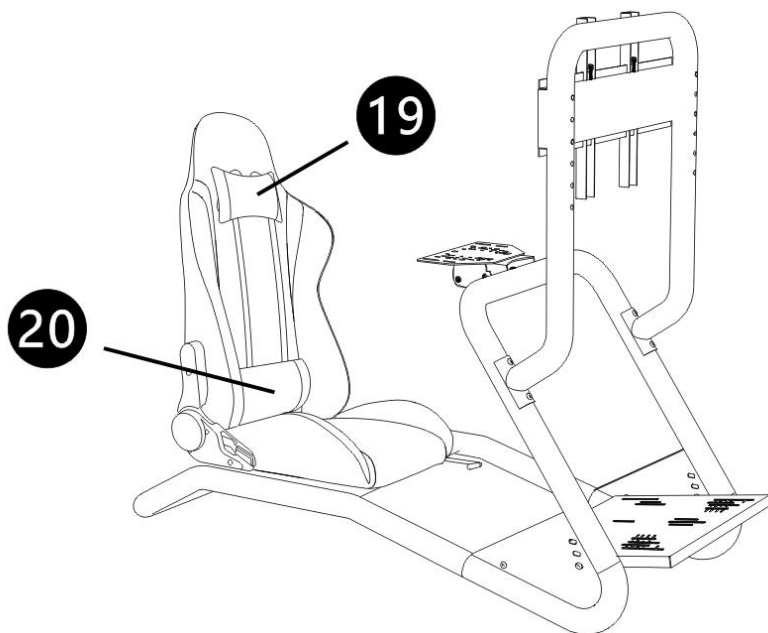

**PASSO 15:**

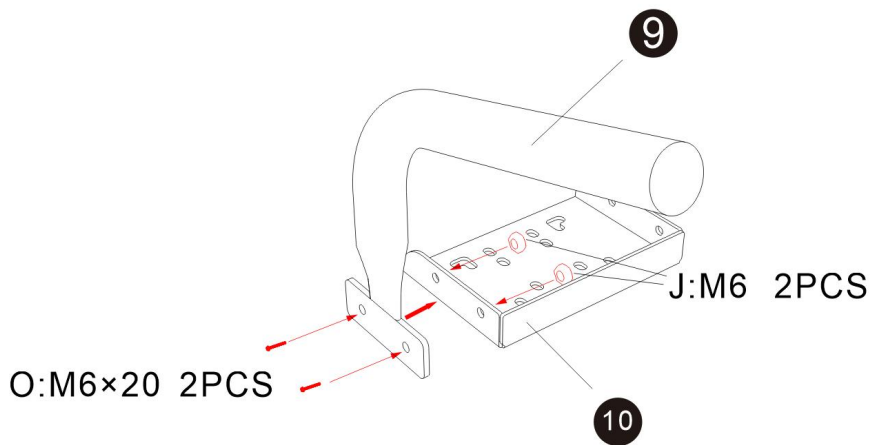

**PASSO 16:**

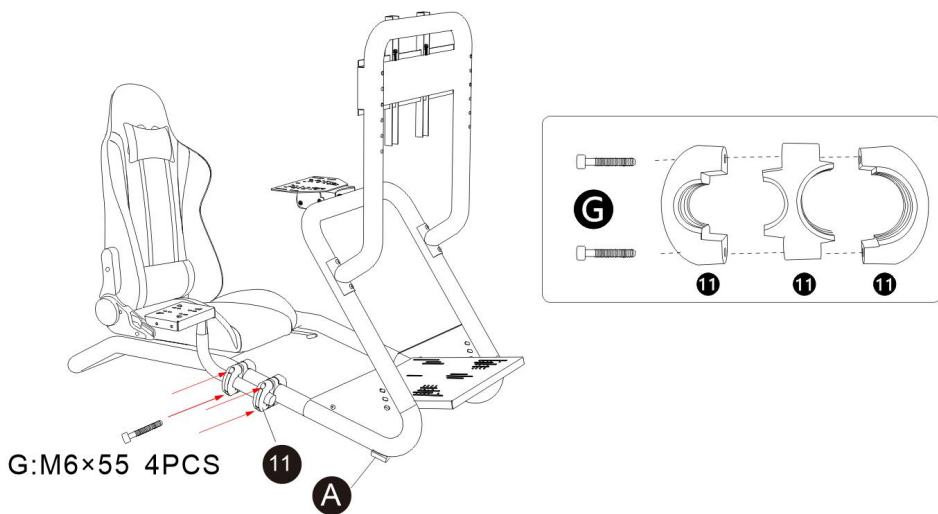

## Montaggio completo



**Produttore:** Shanghaimuxinmuyeyouxiangongsi

**Indirizzo:** Shuangchenglu 803nong11hao1602A-1609shi, baoshanqu, Shanghai 200000 CN.

**Importato in AUS:** SIHAO PTY LTD. 1 ROKEVA STREETEASTWOOD  
Nuovo Galles del Sud 2122 Australia

**Importato negli USA:** Sanven Technology Ltd. Suite 250, 9166 Anaheim  
Luogo, Rancho Cucamonga, CA 91730

<b>UK</b>	<b>REP</b>
-----------	------------

YH CONSULTING LIMITED. C/O YH Consulting  
Limited Office 147, Centurion House, London  
Road, Staines-upon-Thames, Surrey, TW18 4AX

<b>EC</b>	<b>REP</b>
-----------	------------

E-CrossStu GmbH  
Mainzer Landstr.69,  
60329 Frankfurt am Main.





# **VEVOR**

**Affordable. Reliable. Home Improvement.**

## **SOPORTE PARA VOLANTE**

**MODELO: 6013**



# VEVOR

Affordable. Reliable. Home Improvement.

## STEERING WHEEL STAND

**Modelo: 6013**

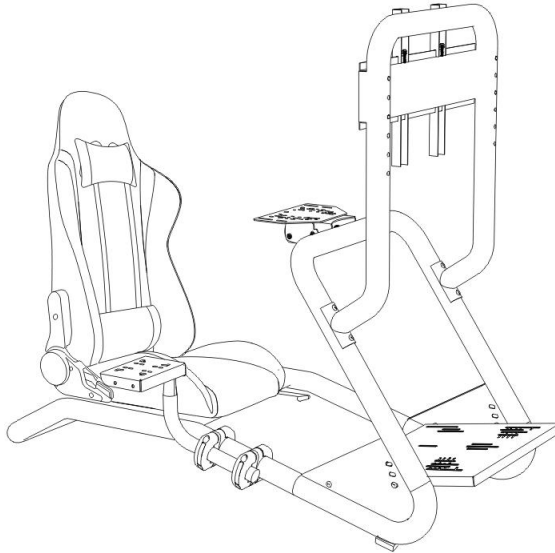

Estas son las instrucciones originales; lea atentamente todas las instrucciones del manual antes de utilizarlo. VEVOR se reserva el derecho de interpretar este manual de usuario. La apariencia del producto dependerá del producto que haya recibido. Le rogamos que no le informemos si hay actualizaciones tecnológicas o de software en nuestro producto.





Advertencia: Para reducir el riesgo de lesiones, el usuario debe leer atentamente el manual de instrucciones.



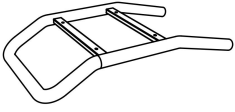
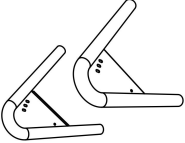

## Atenciones

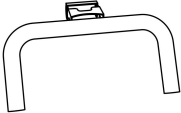
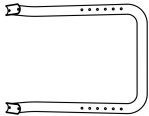

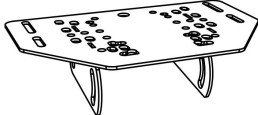
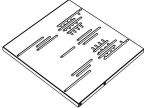
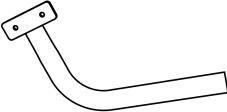
- Instale y utilice el soporte según las instrucciones .
- Por favor, instálelo con moderación, evitando vibraciones fuertes .
- No lo guarde en condiciones de humedad, altas temperaturas o en un lugar polvoriento .
- La estructura del producto es flexible, por lo que se recomienda usar guantes de trabajo durante el montaje. Tenga cuidado con las manos lastimadas al instalarlo.
- Los niños deben estar bajo la supervisión de un adulto cuando utilicen el producto.

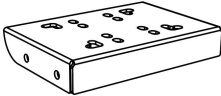
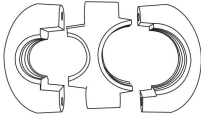

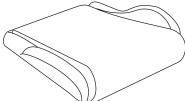
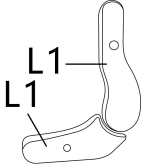
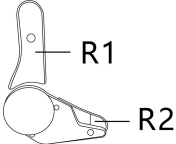

## Guarde el manual.

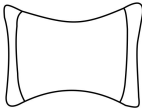

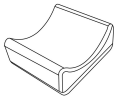
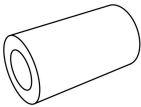
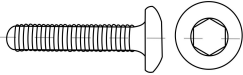
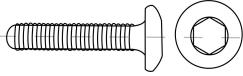
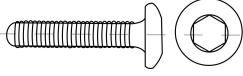
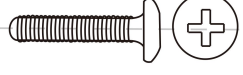
Lista de piezas			
Código	Imagen	Nombre	CANTIDAD AD.
1		pedestal	1
2		Codo de conexión en forma de V	1

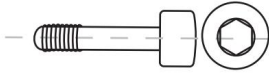
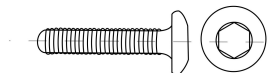
3		Pieza en forma de U	1
4		Monitor 6013 - Soporte en forma de U	1
5		Monitor 6013- Paletas deslizantes verticales	2
6		Monitor 6013 - Placa de acero de barra transversal	1
7		Panel del volante	1
8		Panel de pedales	1
9		Soporte de la palanca de cambios	1

10		Panel de la palanca de cambios	1
11		sujetadores de plástico	2
12		Correa de amarre	6
13		atrás	1
14		asiento	1
15		Cubierta de plástico del ajustador de ángulo - izquierda	1
16		Cubierta de plástico del ajustador de ángulo - derecha	1
17		sillón reclinable izquierdo	1

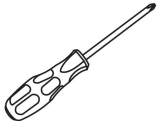
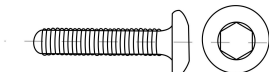
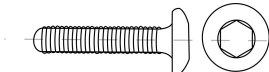
18		sillón reclinable derecho	1
19		Almohada para reposacabezas	1
20		Almohada lumbar	1
A		Almohadilla de soporte de tubería	4
B		Cilindro de plástico	4
do		Tornillo M 8×20	4+1
D		Tornillo M 8×45	4+1
mi		Tornillo M 8×60	4+1
F		Tornillo M 5×30	2+1

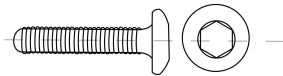
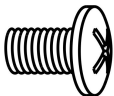
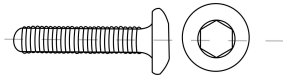
GRAM O		Tornillo M 6×55	4+1
H		Tornillo M6 ×16	12
I		Tuerca de brida M8	8+1
Yo		Tuerca de brida M6	2+6
K		Llave hexagonal de 5 mm	1
Yo		10-13 abierto llave	1
METR O		Destornillador	1
norte		Tornillo M6 ×30	4+1
Oh		Tornillo M6 ×20	6+1

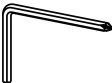
a		Tornillo M 8x25	8+1
b		Tornillo M 5x8	6+1
d		Tornillo M 8x35	4+1
mi		Arandela elástica M8	8+1
F		Arandela plana M8	4+1
gramo		Llave de anillo de 5 mm	1

**Nota:** 12 tornillos M6\*16 y 6 tuercas M6 son gratuitos.

★ Para obtener la lista de kits de asientos y su instalación, consulte el manual de procedimiento de instalación del asiento adjunto.

**PASO 1 :**

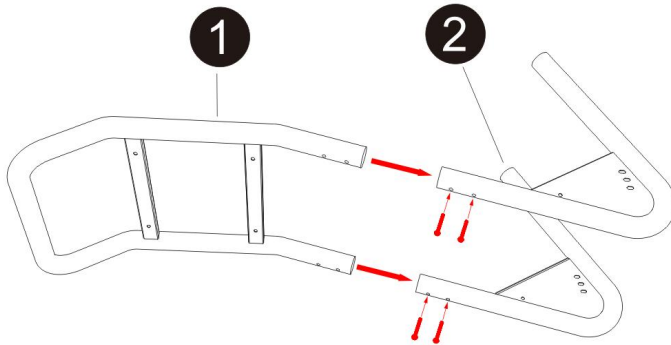

O:M6×20 4PCS

**PASO 2:**

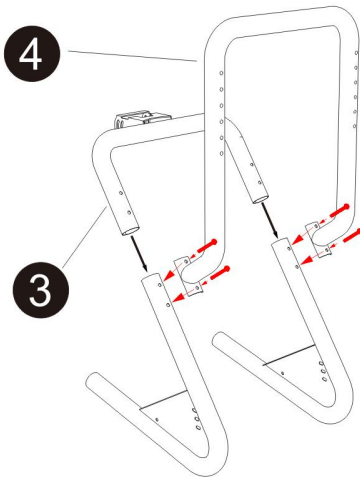

N:M6×30 4PCS

**PASO 3:**

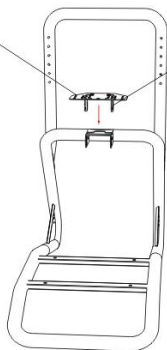
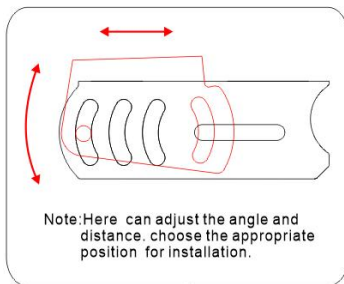
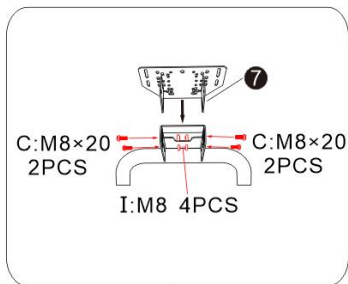

**PASO 4:**

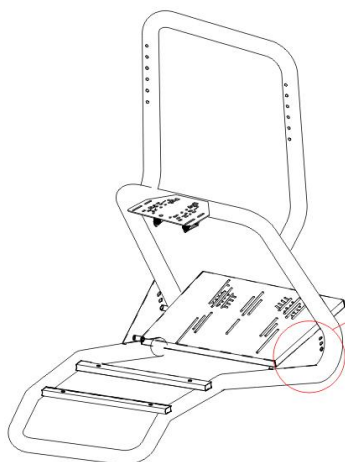

Note: There are 3 adjustable angles available. choose the appropriate angle for installation.

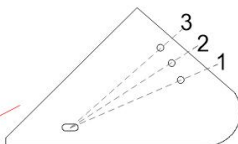

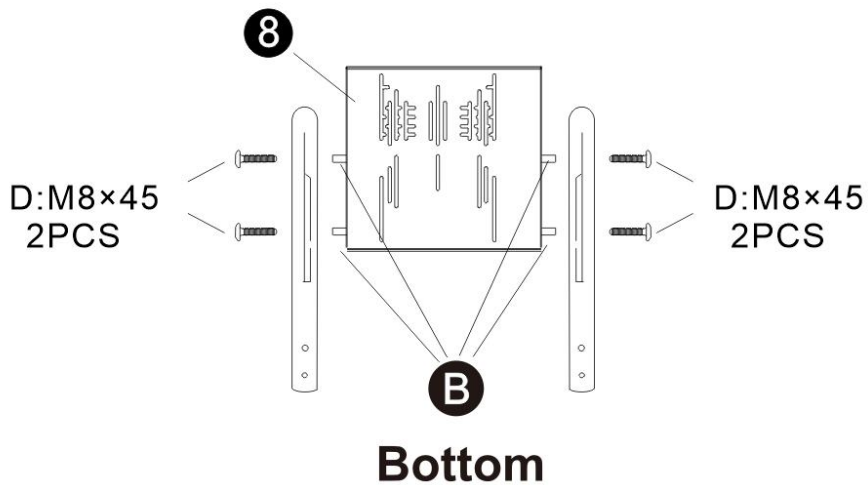

**PASO 5:**

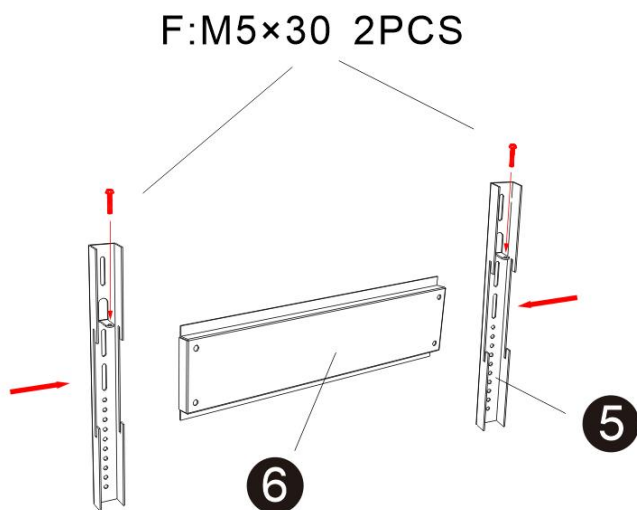

**PASO 6:**

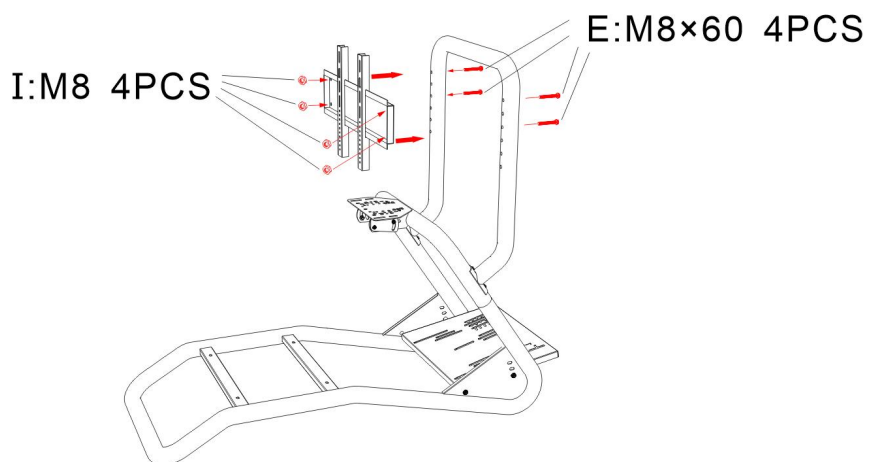

**PASO 7:**

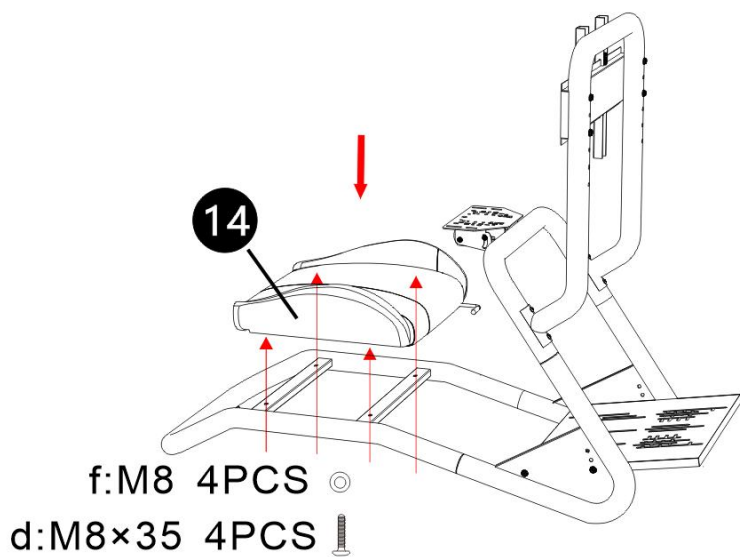

**PASO 8:**

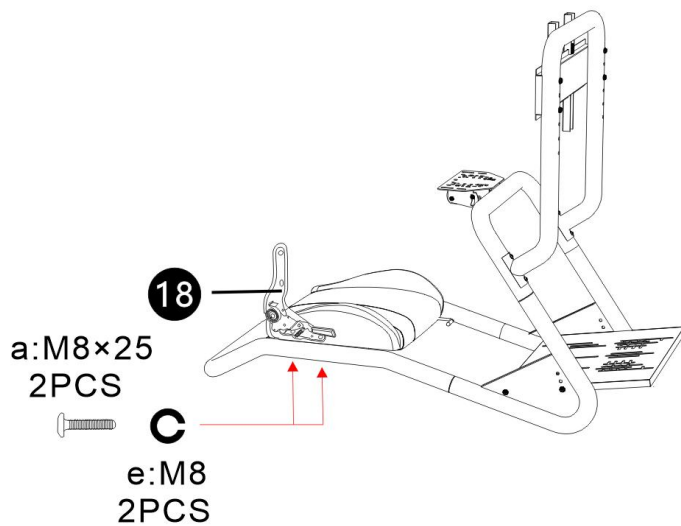

**PASO 9:**

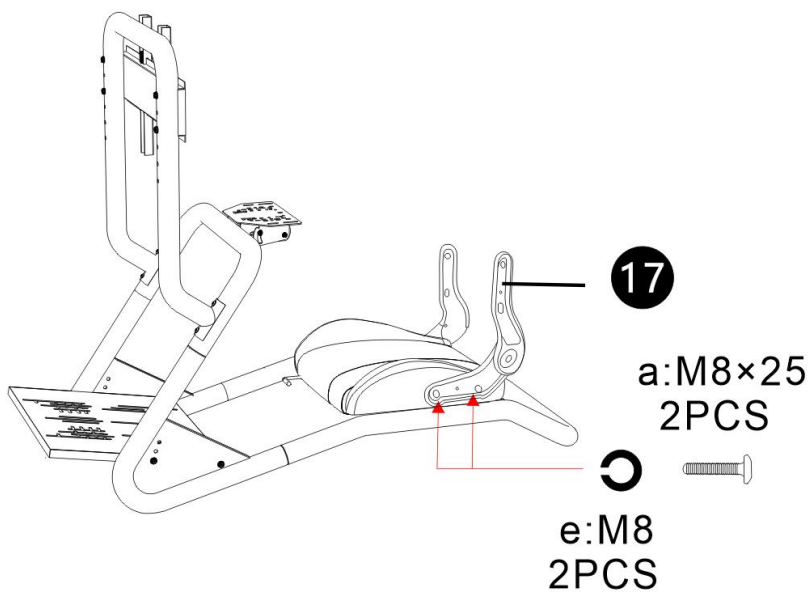

**PASO 1 0:**

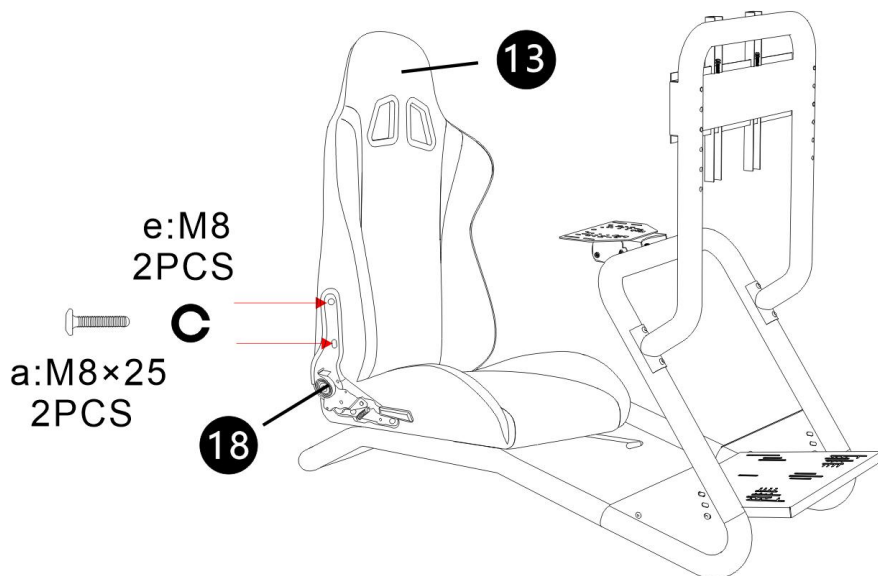

**PASO 1 1:**

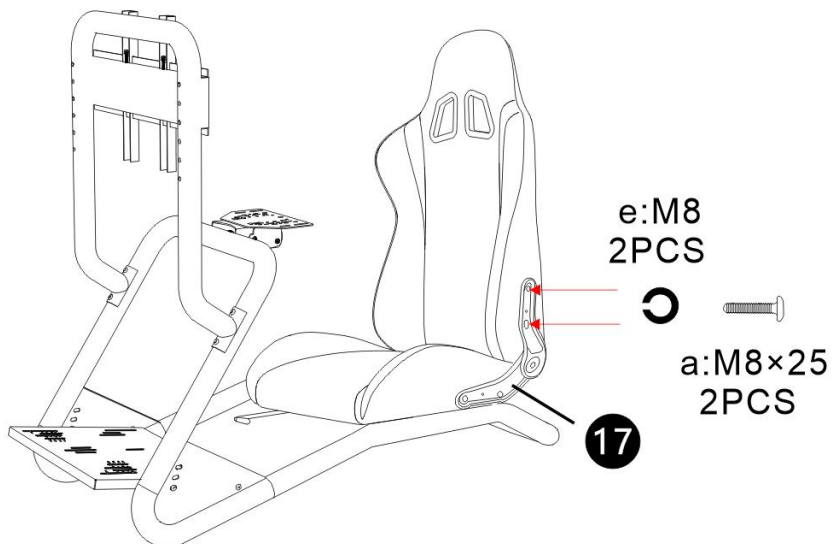

**PASO 1 2:**

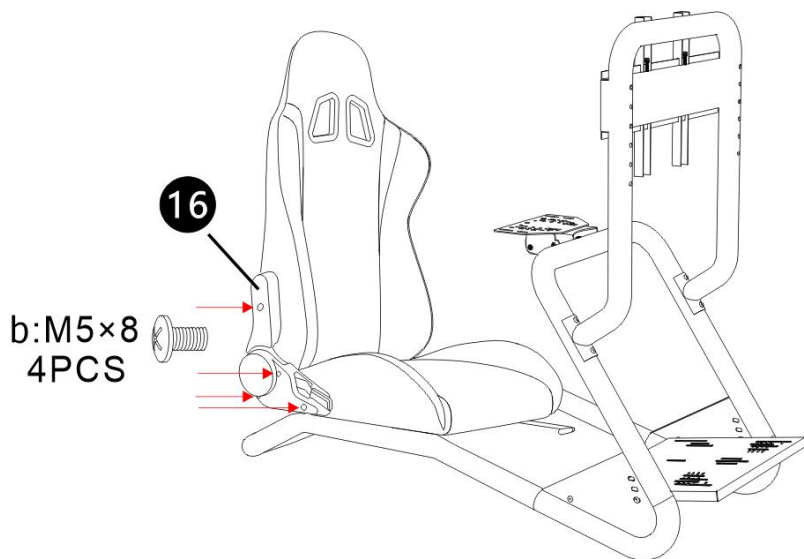

**PASO 1 3:**

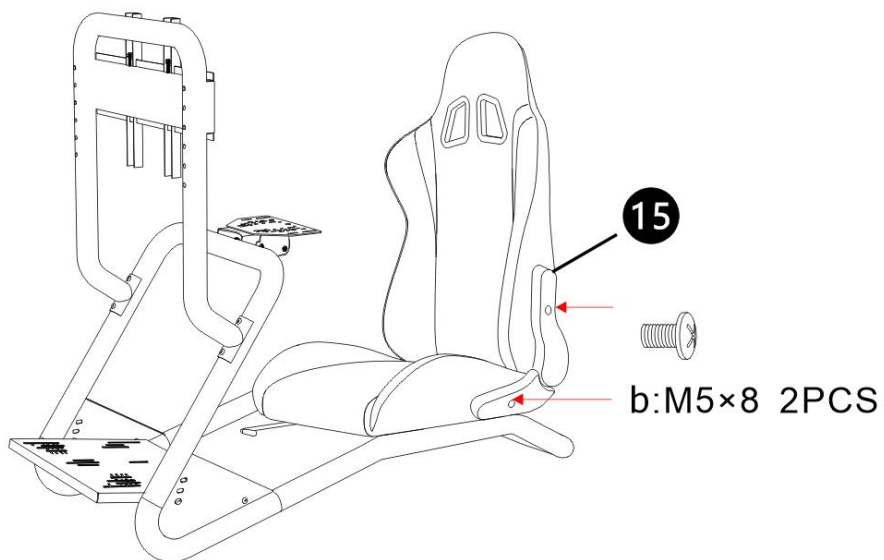

**PASO 14:**

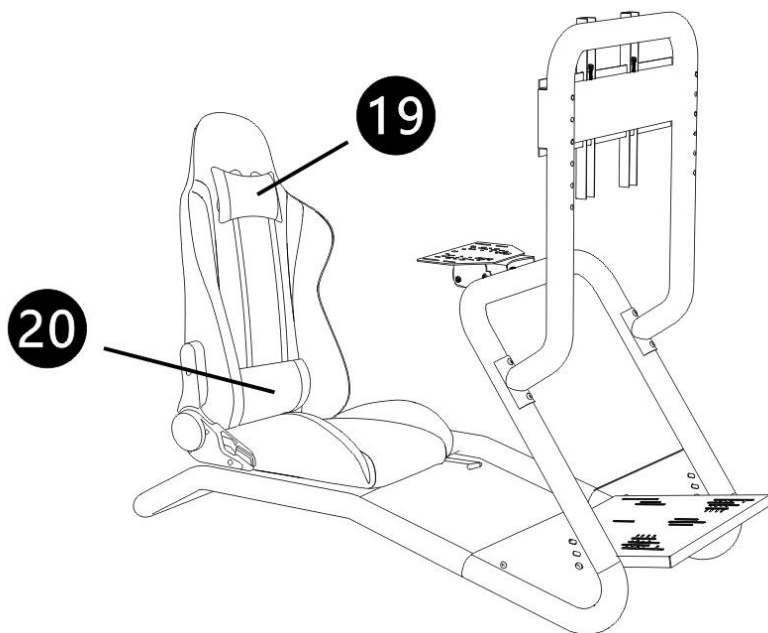

**PASO 15:**

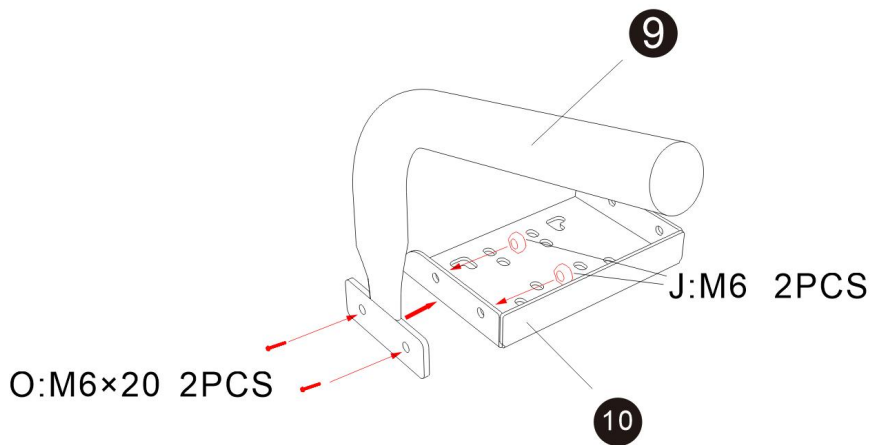

**PASO 16:**

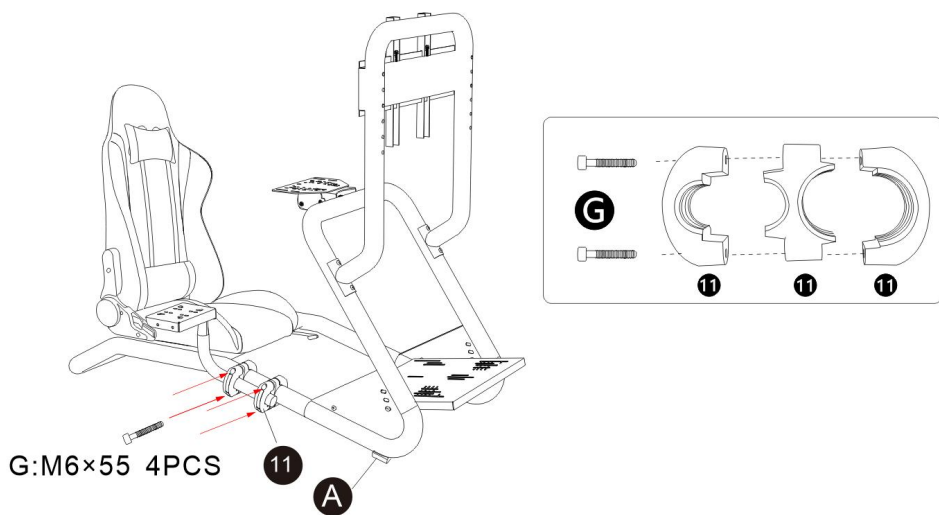

## Montaje completo



**Fabricante:** Shanghaimuxinmuyeyouxiangongsi

**Dirección:** Shuangchenglu 803nong11hao1602A-1609shi, baoshanqu, Shanghai 200000 CN.

**Importado a AUS:** SIHAO PTY LTD. 1 ROKEVA STREET, EASTWOOD NSW 2122 Australia

**Importado a EE. UU.:** Sanven Technology Ltd. Suite 250, 9166 Anaheim Lugar, Rancho Cucamonga, CA 91730

<b>UK</b>	<b>REP</b>
-----------	------------

YH CONSULTING LIMITED. C/O YH Consulting Limited Office 147, Centurion House, London Road, Staines-upon-Thames, Surrey, TW18 4AX

<b>EC</b>	<b>REP</b>
-----------	------------

E-CrossStu GmbH  
Mainzer Landstr.69,  
60329 Frankfurt am Main.





# VEVOR

**Affordable. Reliable. Home Improvement.**

**PODSTAWKA POD KIEROWNICĘ**

**MODEL: 6013**



# VEVOR

Affordable. Reliable. Home Improvement.

## STEERING WHEEL STAND

**Model: 6013**



To jest oryginalna instrukcja obsługi. Przed użyciem prosimy o dokładne zapoznanie się z treścią instrukcji. Firma VEVOR zastrzega sobie prawo do jednoznacznej interpretacji niniejszej instrukcji obsługi. Wygląd produktu zależy od stanu, w jakim go otrzymali Państwo. Prosimy o wyrozumiałość, ale nie będziemy Państwa ponownie informować o aktualizacjach technologicznych lub oprogramowania naszego produktu.







Ostrzeżenie: Aby zminimalizować ryzyko obrażeń, użytkownik powinien uważnie przeczytać instrukcję obsługi.



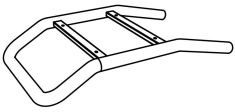
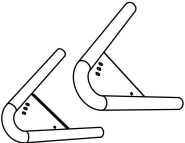
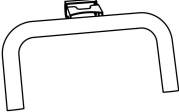

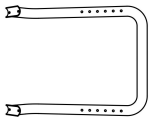
## Uprzejmości

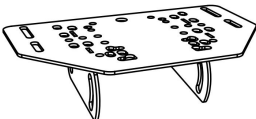
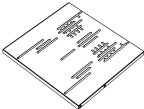

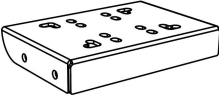
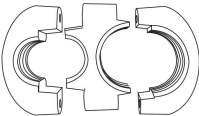
- Proszę zainstalować i używać stojak zgodnie z instrukcją .
- Dokonuj umiarkowanego montażu, unikaj silnych wibracji .
- Nie przechowywać w wilgotnych warunkach, wysokich temperaturach ani w miejscach zakurzonych .
- Produkt jest elastyczny, dlatego podczas montażu należy nosić rękawice robocze. Należy zachować ostrożność podczas instalacji, aby nie zranić dłoni.
- Dzieci powinny używać produktu pod nadzorem osoby dorosłej.

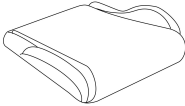
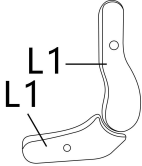
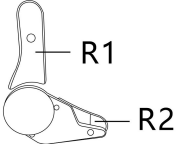

## Zapisz instrukcję.

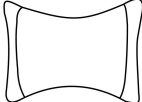

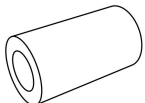
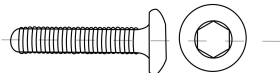
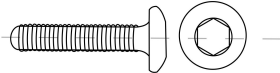
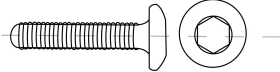
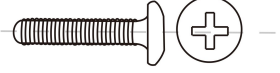
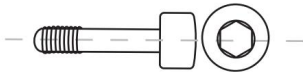
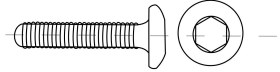

Lista części			
Kod	Zdjęcie	Nazwa	ILOŚĆ
1		pedestał	1
2		Łącznik kolankowy w kształcie litery V	1
3		Część w kształcie litery U	1

4		Monitor 6013 - uchwyt w kształcie litery U	1
5		6013 monitor- Pionowa łopatka ślizgowa	2
6		Monitor 6013 - Płyta stalowa poprzeczki	1
7		Panel kierownicy	1
8		Panel pedałów	1
9		Uchwyt dźwigni zmiany biegów	1
10		Panel dźwigni zmiany biegów	1
11		Elementy złączne z tworzywa sztucznego	2

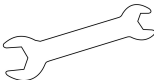
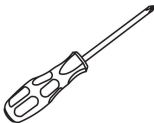
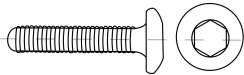
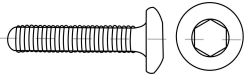
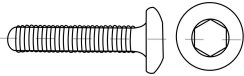
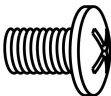
12		Pas mocujący	6
13		z powrotem	1
14		siedziba	1
15		Plastikowa osłona regulatora kąta - lewa	1
16		Plastikowa osłona regulatora kąta - prawa	1
17		fotel rozkładany-lewy	1
18		fotel rozkładany po prawej stronie	1
19		Poduszka zagiłwkowa	1

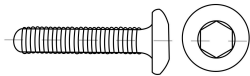
20		Poduszka lędźwiowa	1
A		Podkładka pod rurę	4
B		Cylinder plastikowy	4
C		Śruba M 8×20	4+1
D		Śruba M 8×45	4+1
mi		Śruba M 8×60	4+1
F		Śruba M 5×30	2+1
G		Śruba M 6×55	4+1
H		Śruba M6 ×16	12

I		Nakrętka kołnierzowa M8	8+1
J		Nakrętka kołnierzowa M6	2+6
K		Klucz imbusowy 5mm	1
L		10-13 otwarte klucz do nakrętek	1
M		Śrubokręt	1
N		Śruba M6 ×30	4+1
O		Śruba M6 ×20	6+1
A		Śruba M 8×25	8+1
B		Śruba M 5×8	6+1

D		Śruba M 8×35	4+1
mi		Podkładka sprężysta M8	8+1
F		Podkładka płaska M8	4+1
G		Klucz oczkowy 5mm	1

**Uwaga:** 12 śrub M6\*16 i 6 nakrętek M6 jest dostarczanych w komplecie.

★ Listę zestawów fotelików i sposobów ich montażu znajdziesz w załączonej instrukcji montażu fotelika.

### KROK 1 :

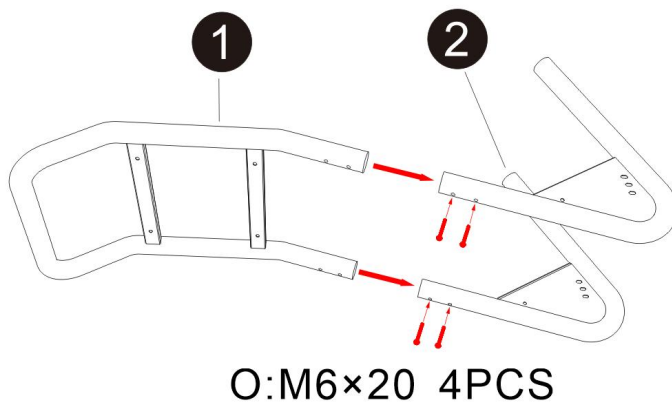

## KROK 2:

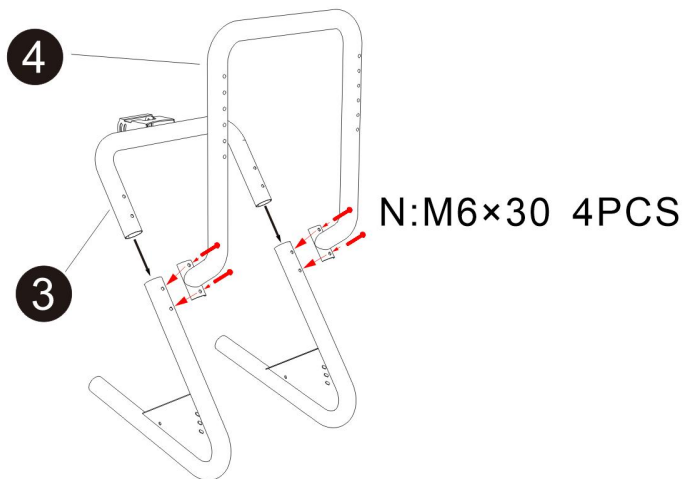

## KROK 3:

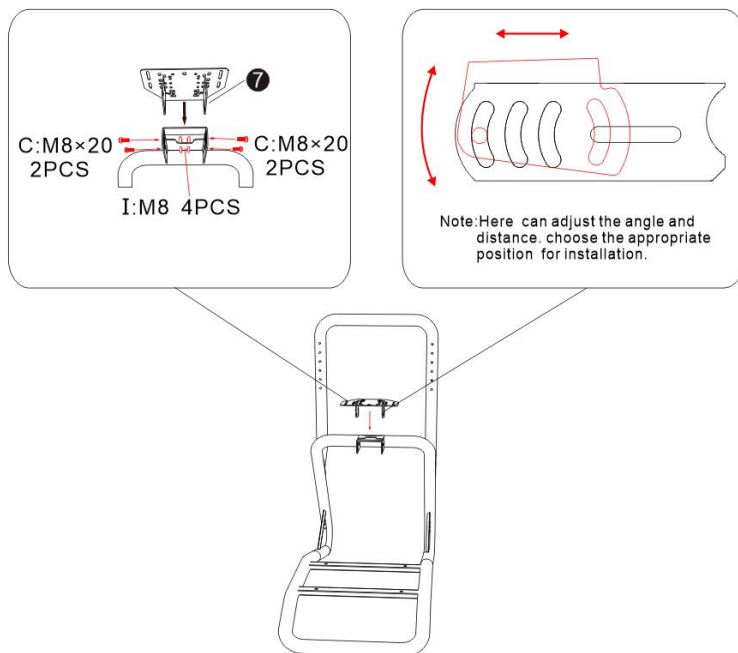

## KROK 4:

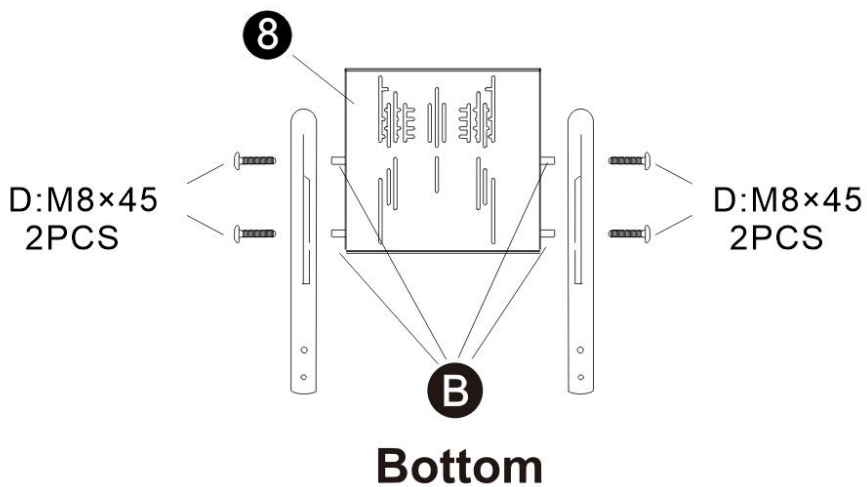
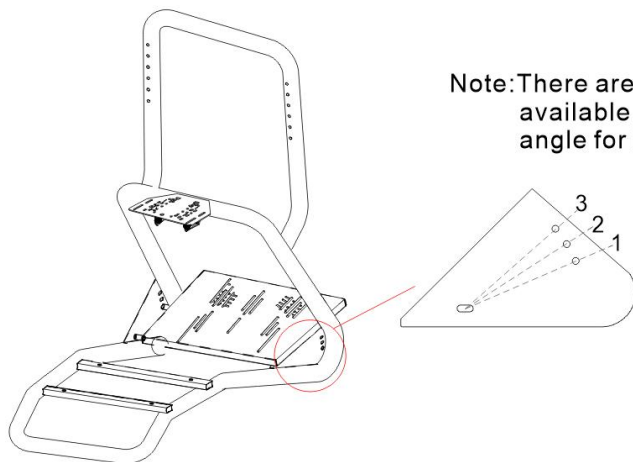

**KROK 5:**

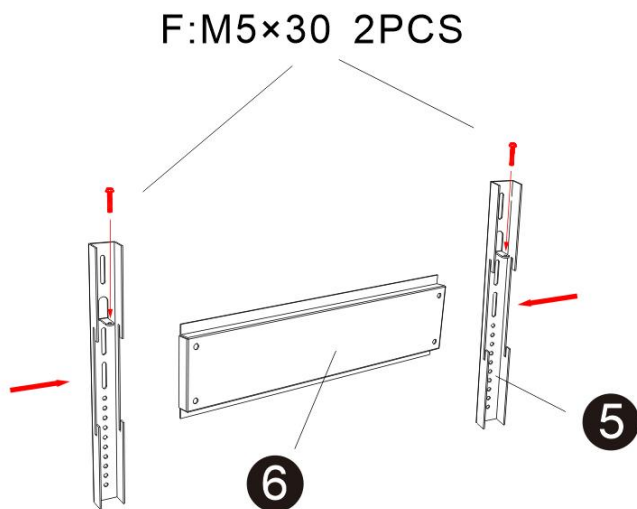

**KROK 6:**

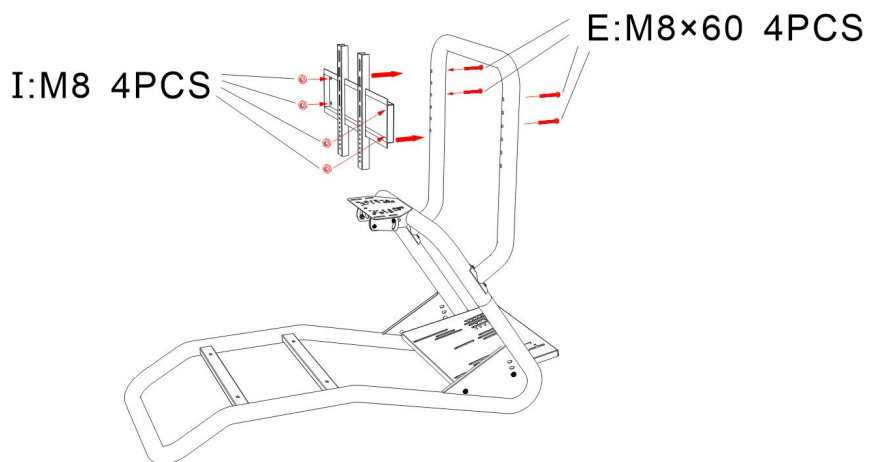

## KROK 7:

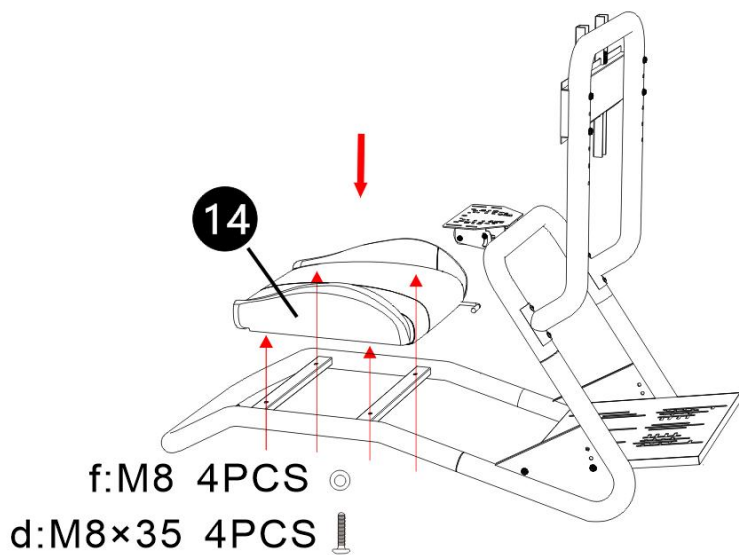

## KROK 8:

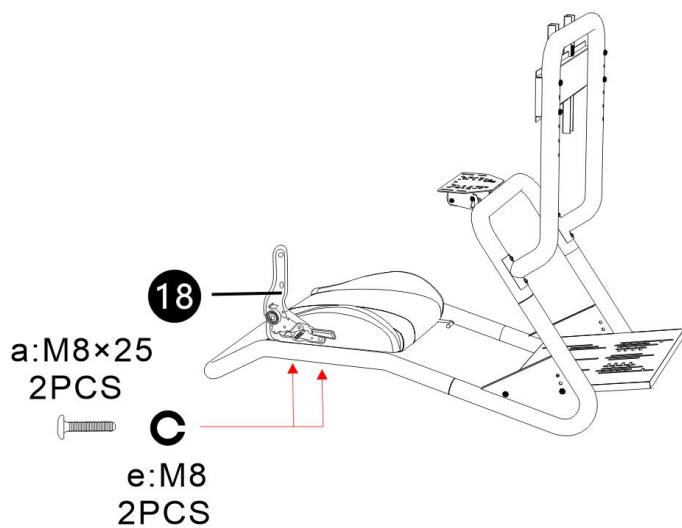

## KROK 9:

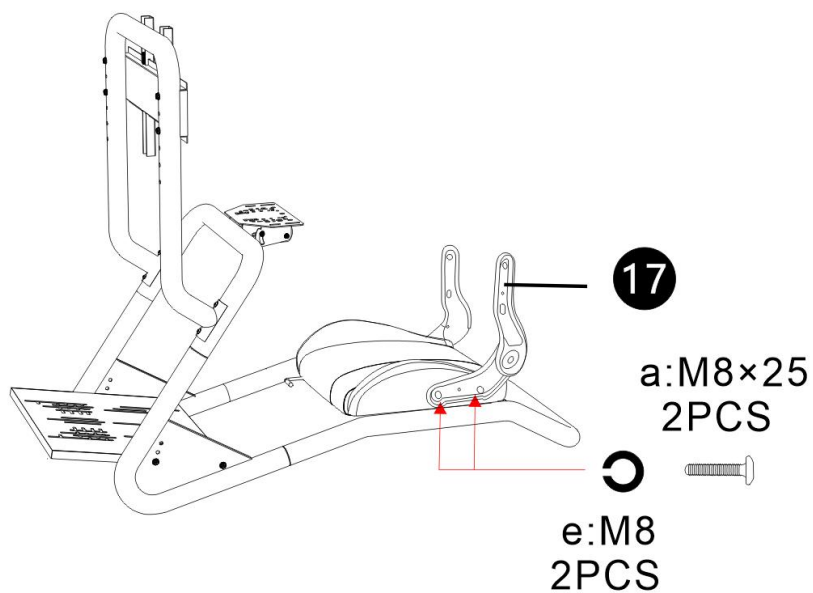

## KROK 10:

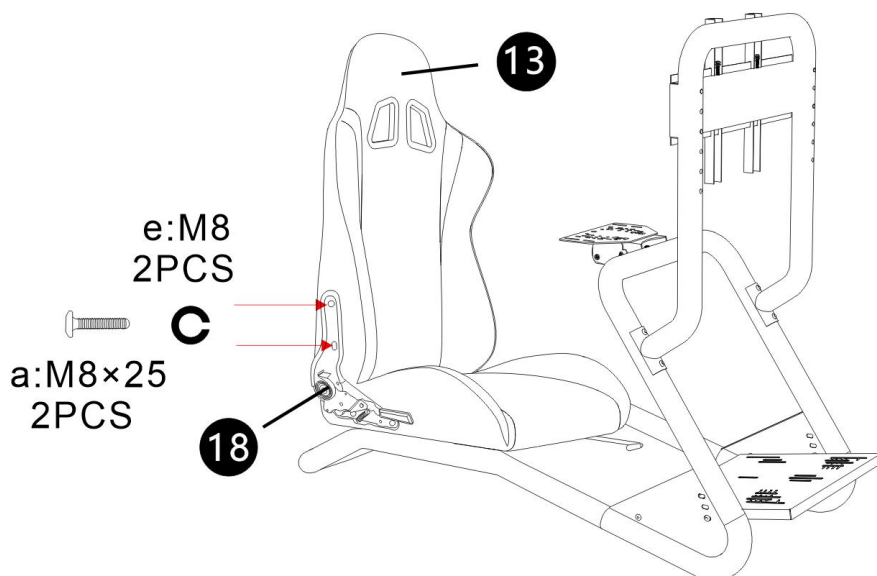

## KROK 1 1:

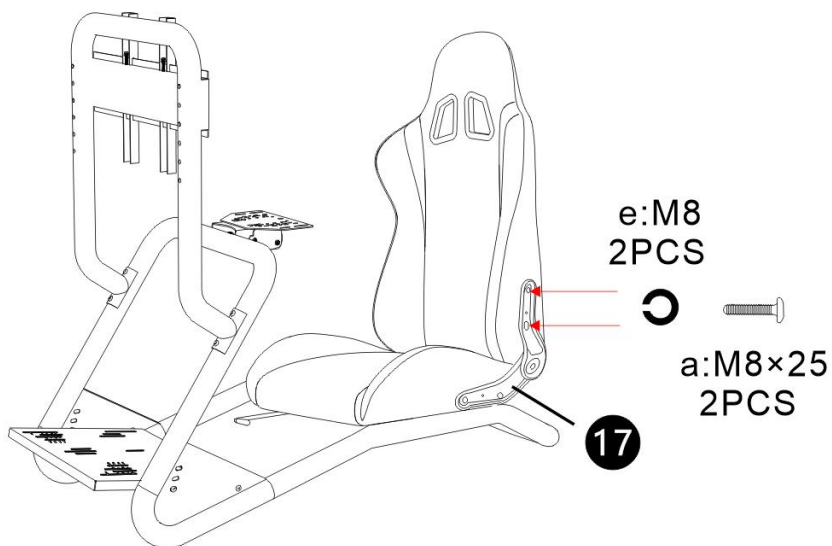

## KROK 1 2:

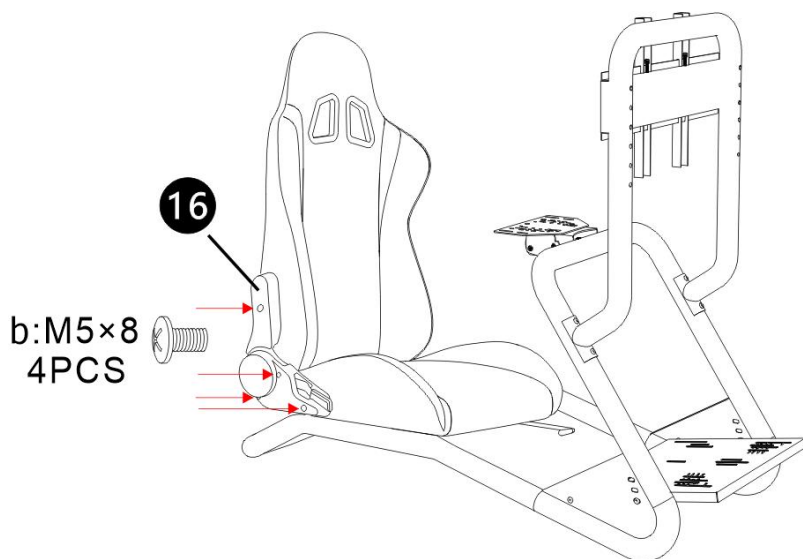

**KROK 13:**

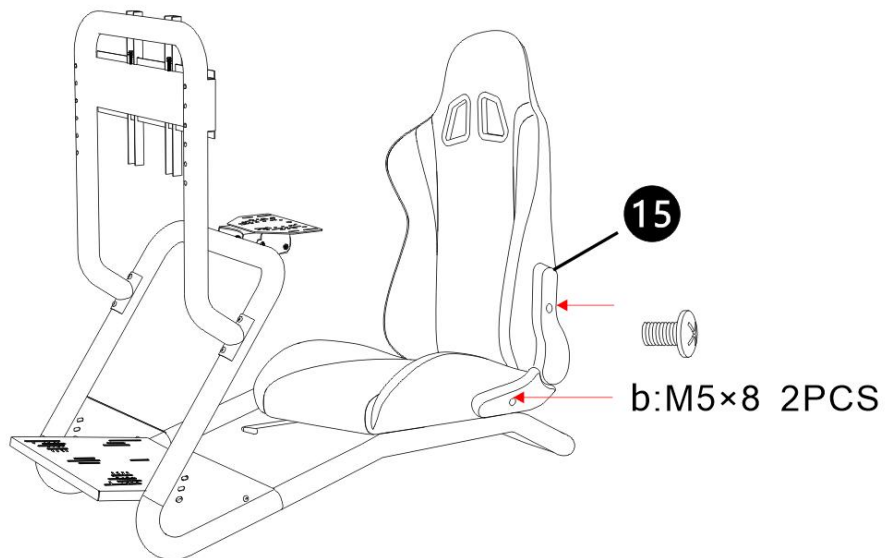

**KROK 14:**

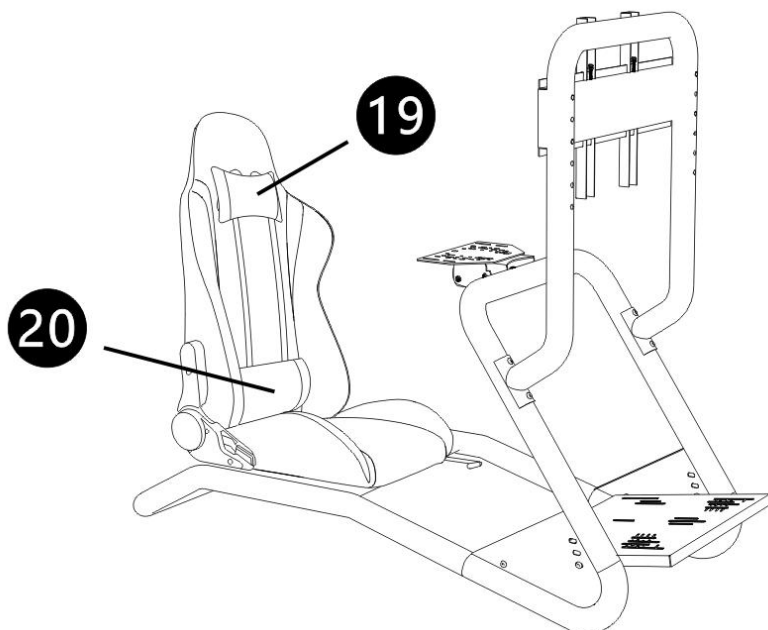

## KROK 1 5:

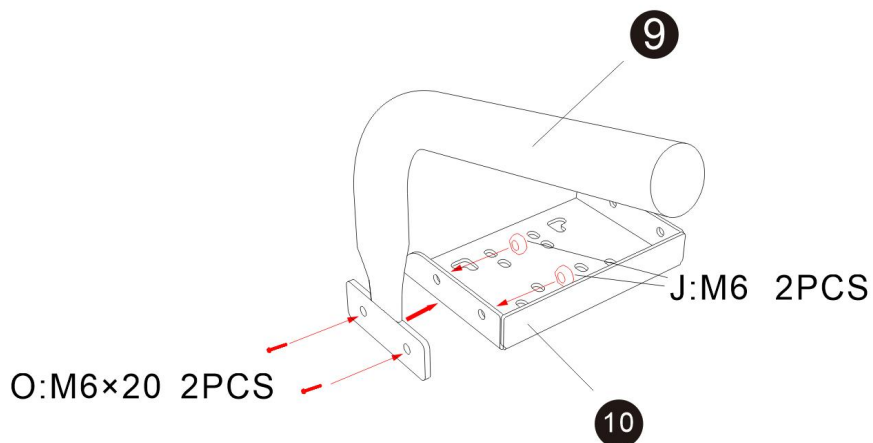

## KROK 1 6:

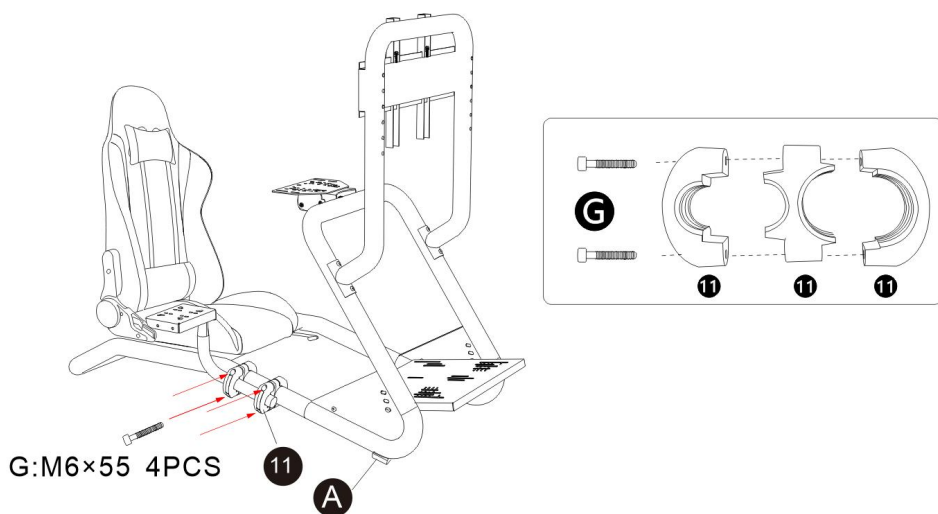

## Kompletny montaż



**Producent:** Shanghaimuxinmuyeyouxiangongsi

**Adres:** Shuangchenglu 803nong11hao1602A-1609shi, baoshanqu, szanghaj 200000 CN.

**Importowane do AUS:** SIHAO PTY LTD. 1 ROKEVA

STREETEASTWOOD

NSW 2122 Australia

**Importowane do USA:** Sanven Technology Ltd. Suite 250, 9166 Anaheim Miejsce, Rancho Cucamonga, CA 91730

<b>UK</b>	<b>REP</b>
-----------	------------

YH CONSULTING LIMITED. C/O YH Consulting Limited Office 147, Centurion House, London Road, Staines-upon-Thames, Surrey, TW18 4AX

<b>EC</b>	<b>REP</b>
-----------	------------

E-CrossStu GmbH  
Mainzer Landstr.69,  
60329 Frankfurt am Main.





# **VEVOR**

**Affordable. Reliable. Home Improvement.**

## **STUURWIELSTANDAARD**

**MODEL: 6013**



# VEVOR

Affordable. Reliable. Home Improvement.

## STEERING WHEEL STAND

**Model: 6013**



Dit is de originele handleiding. Lees alle instructies zorgvuldig door voordat u het product gebruikt. VEVOR behoudt zich het recht voor om de gebruiksaanwijzing duidelijk te interpreteren. Het uiterlijk van het product is afhankelijk van het product dat u hebt ontvangen. Neemt u het ons niet kwalijk dat we u niet meer op de hoogte stellen van eventuele technologische of software-updates voor ons product.







Waarschuwing: om het risico op letsel te verminderen, moet de gebruiker de gebruiksaanwijzing zorgvuldig lezen.



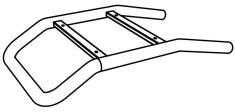
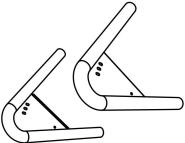
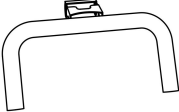

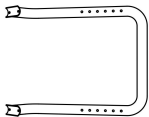
## Aandacht

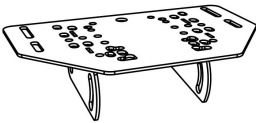
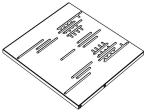

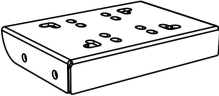
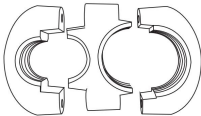
- Installeer en gebruik de standaard volgens de instructies .
- Installeer het voorzichtig en vermijd sterke trillingen .
- Niet bewaren op een vochtige plaats, bij hoge temperaturen of op een stoffige plaats .
- De productstructuur is flexibel. Draag werkhandschoenen tijdens de montage. Let op een pijnlijke hand tijdens de installatie.
- Kinderen dienen dit product onder toezicht van een volwassene te gebruiken.

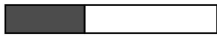

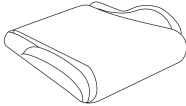
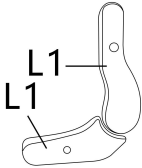
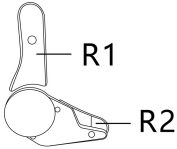

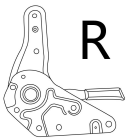
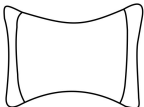
## Bewaar de handleiding.

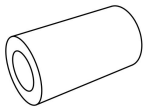
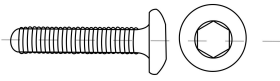
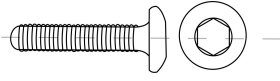
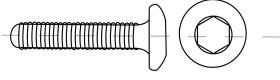
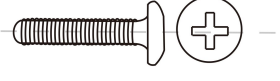
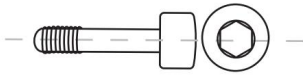
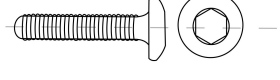

Onderdelenlijst			
Code	Afbeelding	Naam	AANTAL
1		voetstuk	1
2		V-vormige aansluitbocht	1
3		U-vormig onderdeel	1

4		6013 monitor - U-vormige beugel	1
5		6013 monitor- Verticale schuifvleugel	2
6		6013 monitor- Dwarsbalk stalen plaat	1
7		Stuurwielpaneel	1
8		Pedaalpaneel	1
9		Versnellingshend elhouder	1
10		Versnellingspook paneel	1
11		Kunststof bevestigingsmiddelen	2

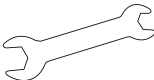
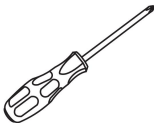
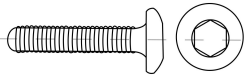
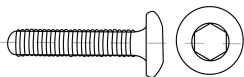
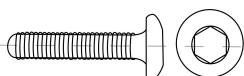
12		Vastzetriem	6
13		rug	1
14		stoel	1
15		Hoekversteller kunststof afdekking - links	1
16		Hoekversteller kunststof afdekking - rechts	1
17		relaxfauteuil links	1
18		relaxfauteuil rechts	1
19		Hoofdsteunkusse n	1

20		Lendenkussen	1
A		Buisondersteuningpad	4
B		Kunststof cilinder	4
C		Schroef M 8x20	4+1
D		Schroef M 8x45	4+1
E		Schroef M 8x60	4+1
F		Schroef M 5x30	2+1
G		Schroef M 6x55	4+1
H		Schroef M6 x16	12

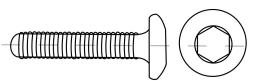
I		Flensmoer M8	8+1
J		Flensmoer M6	2+6
K		Inbussleutel 5mm	1
L		10-13 open einde moersleutel	1
M		Schroevendraaier	1
N		Schroef M6 x30	4+1
O		Schroef M6 x20	6+1
A		Schroef M 8x25	8+1
B		Schroef M 5x8	6+1

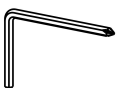
D		Schroef M 8×35	4+1
en		Veerring M8	8+1
F		Platte ring M8	4+1
G		Ringsleutel 5mm	1

**Let op:** 12 schroeven M6\*16 en 6 moeren M6 zijn inbegrepen.

★ Raadpleeg de bijgevoegde handleiding met de stoelinstallatieprocedure voor een lijst met stoelsets en de installatie ervan.

### STAP 1 :

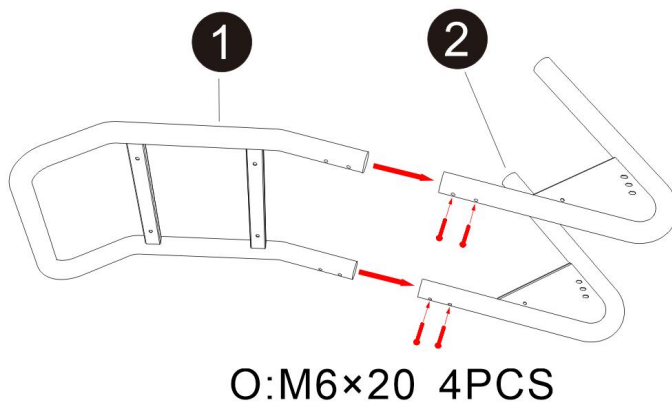

**STAP 2:**

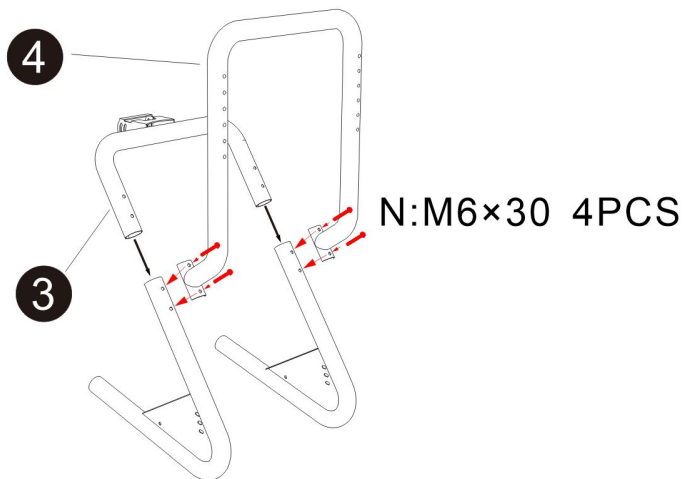

**STAP 3:**

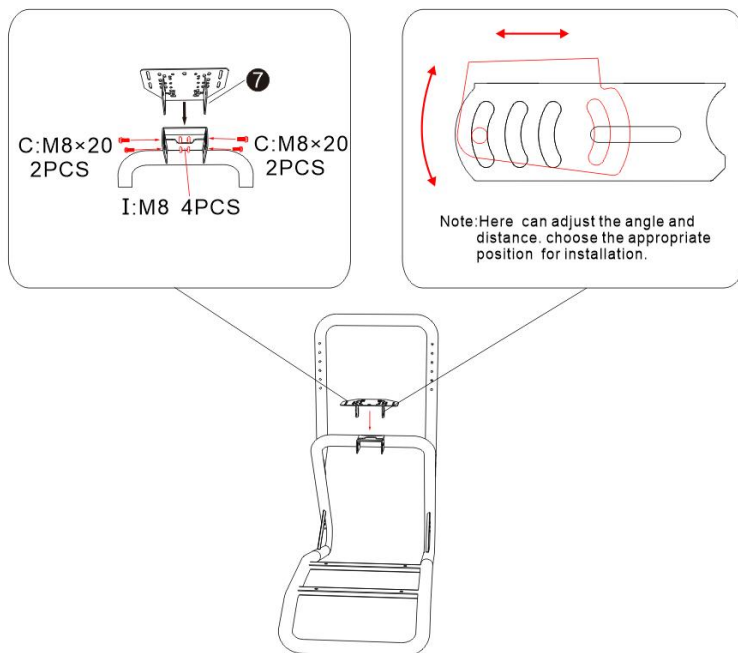

**STAP 4:**

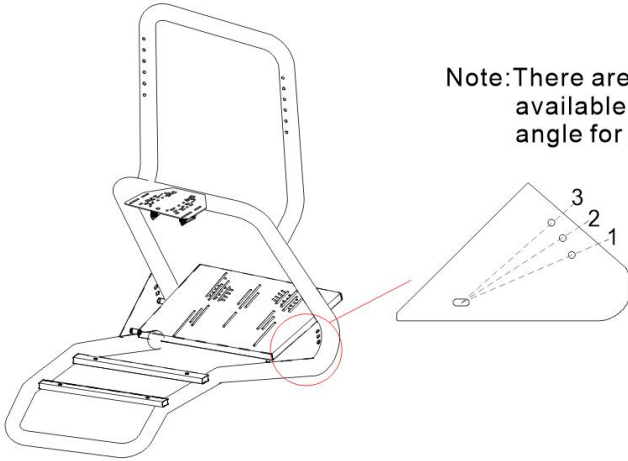

Note: There are 3 adjustable angles available. choose the appropriate angle for installation.

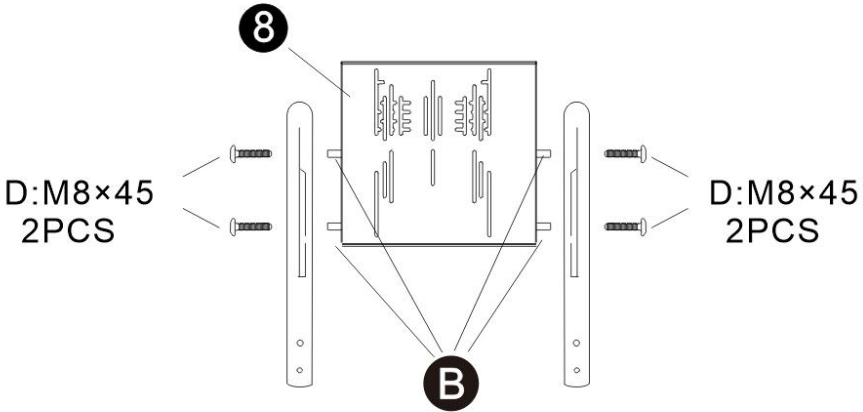

**Bottom**

**STAP 5:**

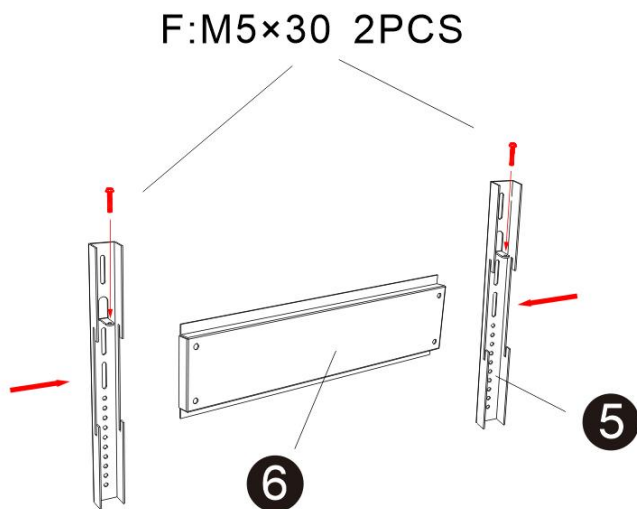

**STAP 6:**

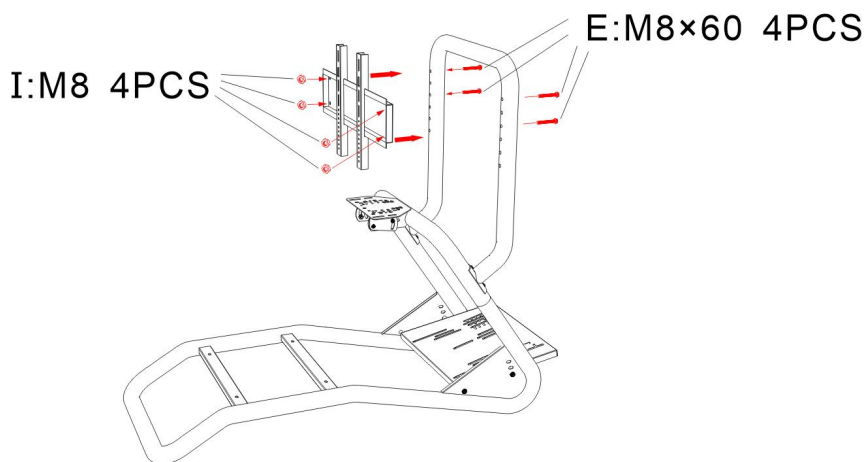

## STAP 7:

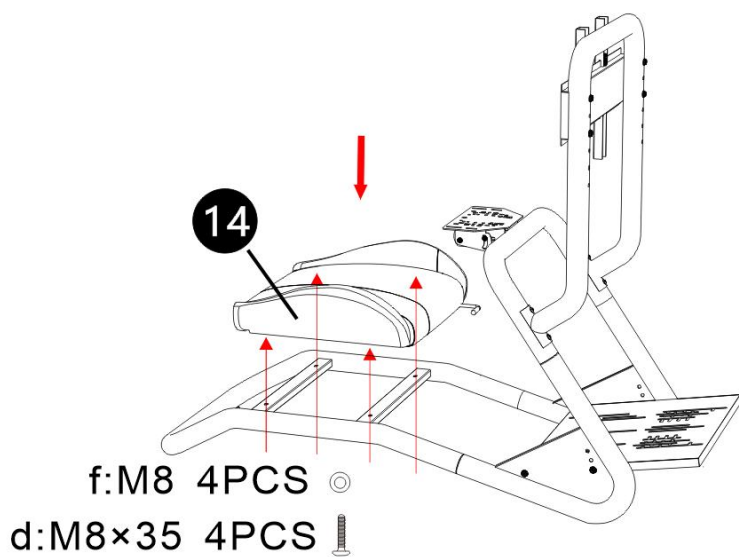

## STAP 8:

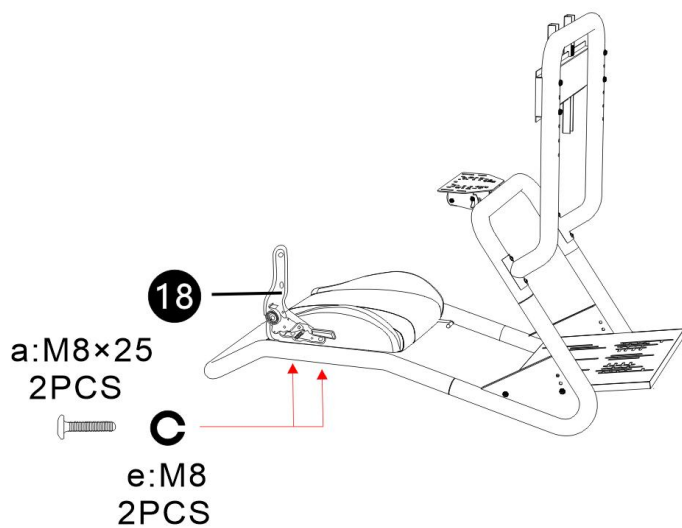

**STAP 9:**

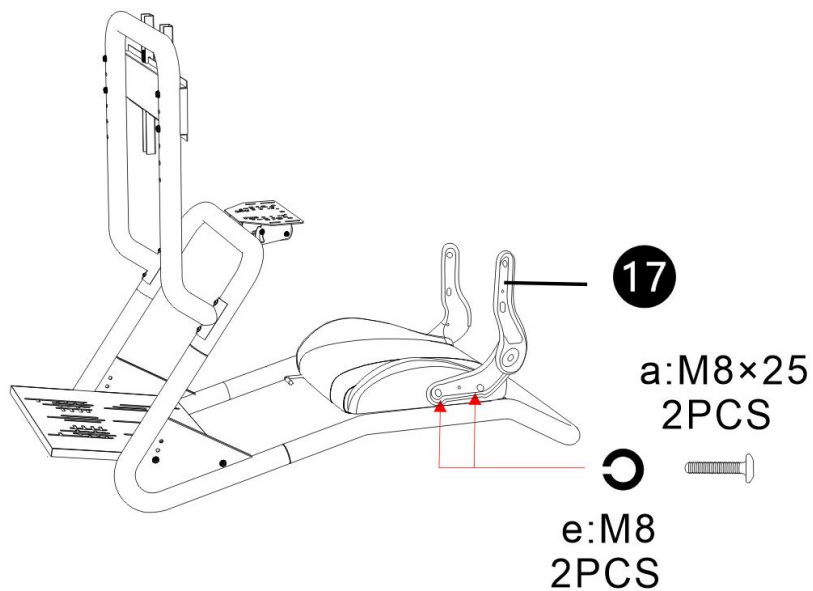

**STAP 10:**

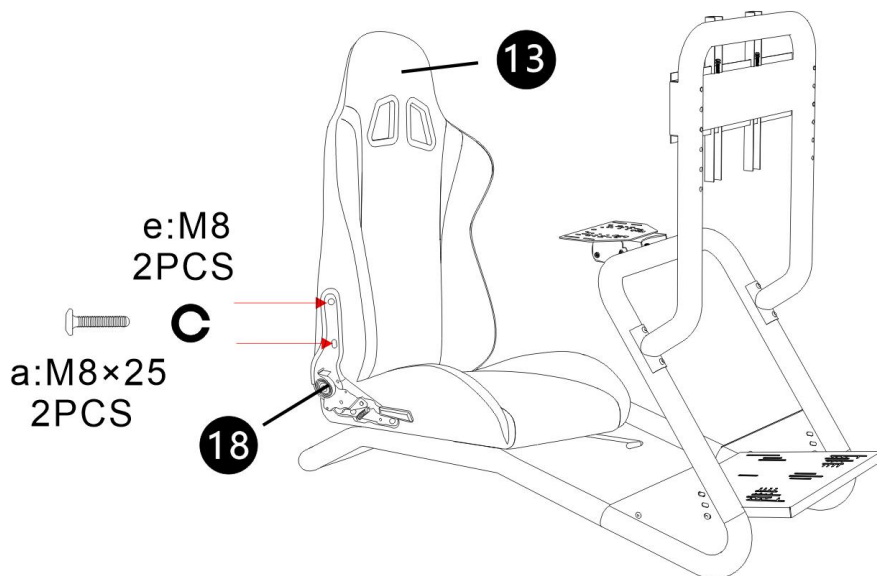

## STAP 1 1:

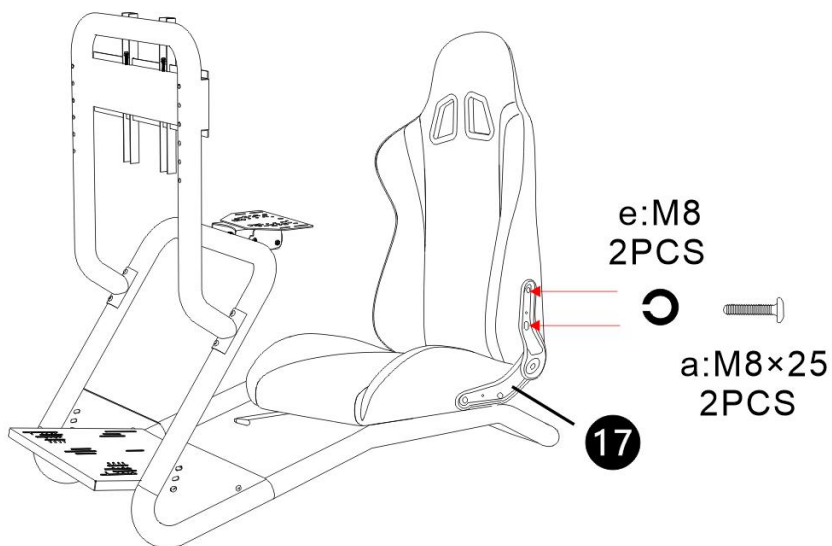

## STAP 1 2:

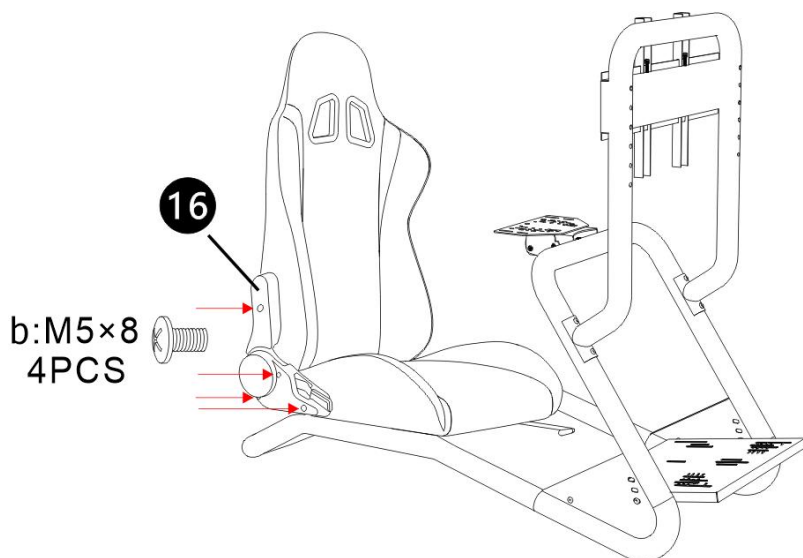

**STAP 1 3:**

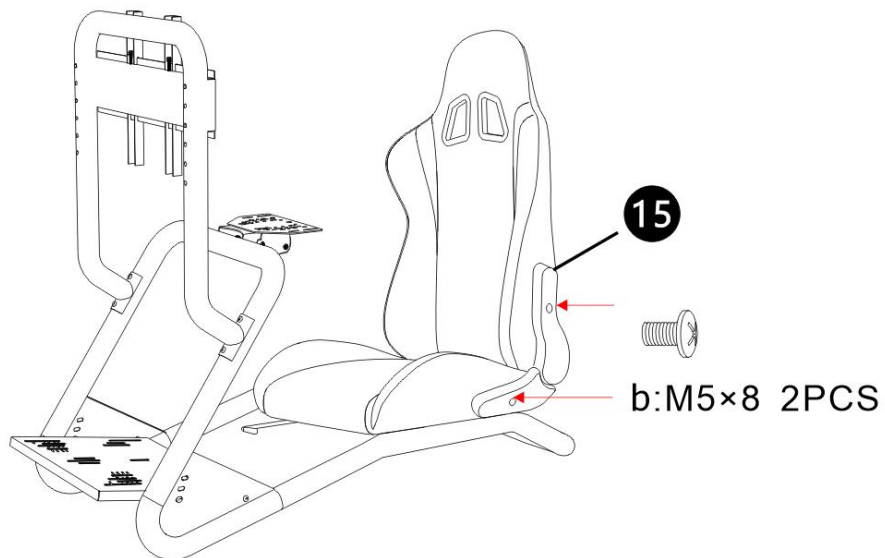

**STAP 14:**

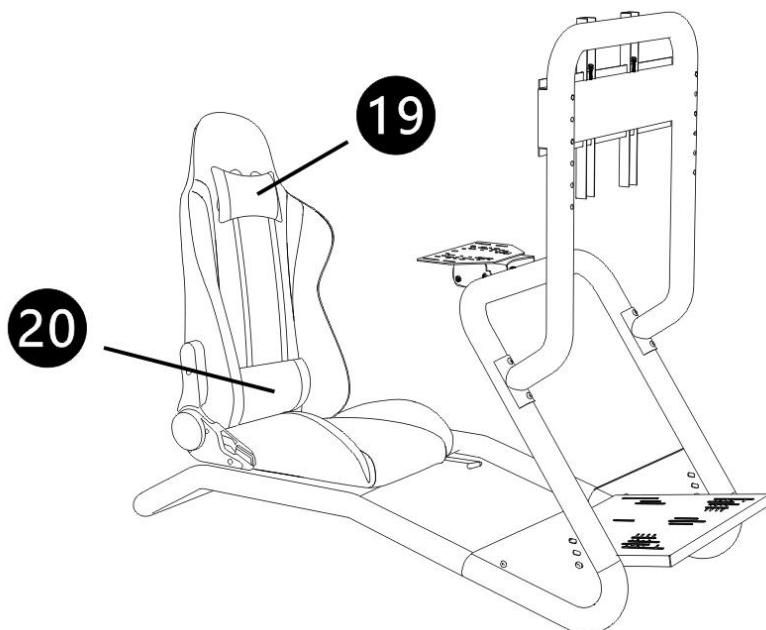

## STAP 1 5:

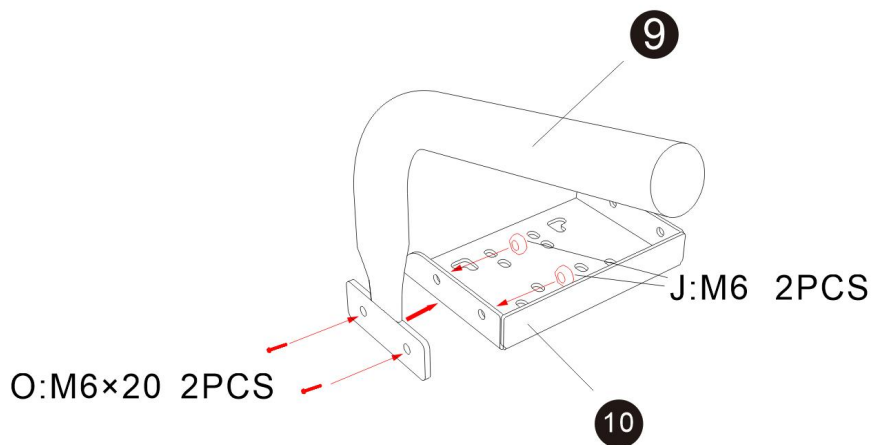

## STAP 1 6:

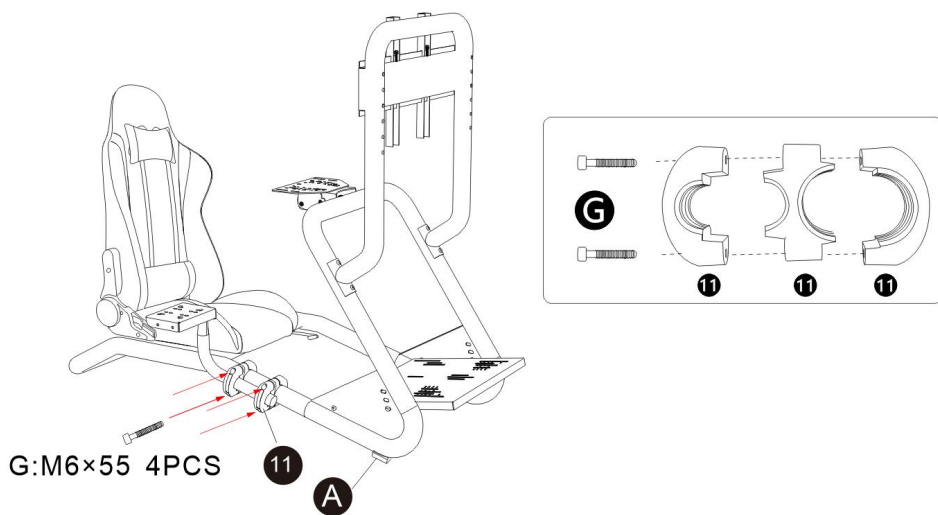

## Volledige montage



**Fabrikant:** Shanghaimuxinmuyeyouxiangongsi

**Adres:** Shuangchenglu 803nong11hao1602A-1609shi, baoshanqu, shanghai 200000 CN.

**Geïmporteerd naar AUS:** SIHAO PTY LTD. 1 ROKEVA  
STREETEASTWOOD

NSW 2122 Australië

**Geïmporteerd naar de VS:** Sanven Technology Ltd. Suite 250, 9166  
Anaheim

Plaats, Rancho Cucamonga, CA 91730

<b>UK</b>	<b>REP</b>
-----------	------------

YH CONSULTING LIMITED. C/O YH Consulting  
Limited Office 147, Centurion House, London  
Road, Staines-upon-Thames, Surrey, TW18 4AX

<b>EC</b>	<b>REP</b>
-----------	------------

E-CrossStu GmbH  
Mainzer Landstr.69,  
60329 Frankfurt am Main.







# VEVOR

**Affordable. Reliable. Home Improvement.**

**RATTSTYCK**

**MODELL: 6013**



# VEVOR

Affordable. Reliable. Home Improvement.

## STEERING WHEEL STAND

**Modell: 6013**

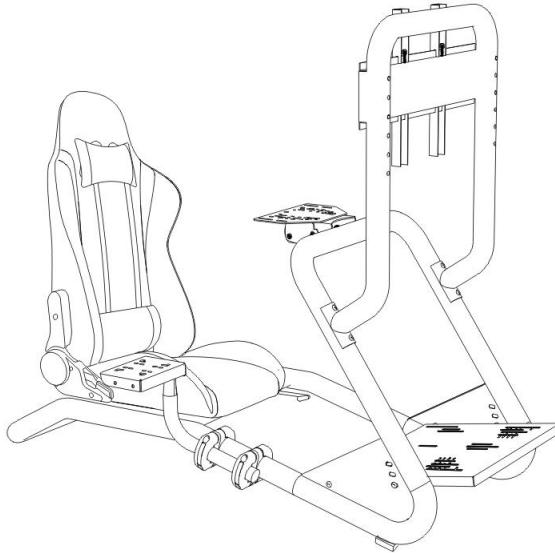

Detta är originalinstruktionerna, vänligen läs alla instruktioner noggrant innan du använder produkten. VEVOR förbehåller sig en tydlig tolkning av vår användarmanual. Produktens utseende ska vara beroende av den produkt du mottagit. Vi ber om ursäkt för att vi inte kommer att informera dig igen om det finns några teknik- eller programuppdateringar för vår produkt.



Varning – För att minska risken för skador måste användaren läsa instruktionsmanualen noggrant.





## Uppmärksamhet

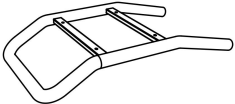
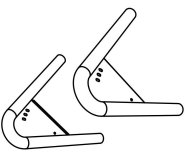
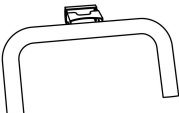

- Installera och använd stativet enligt anvisningarna .
- Installera med måtta och undvik starka vibrationer .
- Förvara inte i fuktiga förhållanden, höga temperaturer eller dammiga platser .
- Produktstrukturen är flexibel, använd arbetshandskar vid montering. Var försiktig med värkande händer vid installation.
- Barn bör vara under vuxenövervakning när de använder produkten.

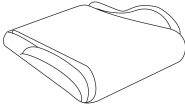
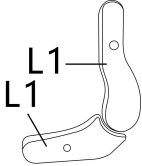
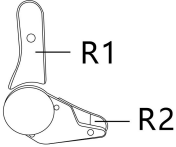

## Spara manualen.

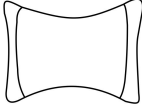

Dellista			
Koda	Bild	Namn	ANTAL
1		pedestal	1
2		V-formad anslutningsböj	1
3		U-formad del	1

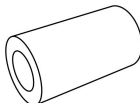
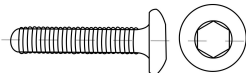
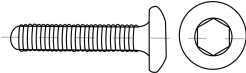
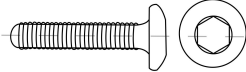
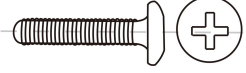
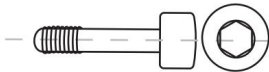
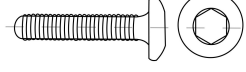
4		6013 monitor - U-formad konsol	1
5		6013 monitor- Vertikal glidvinge	2
6		6013 monitor - Tvärstångsstålp åt	1
7		Rattpanel	1
8		Pedalpanel	1
9		Växelspakshållar e	1
10		Växelspakspanel	1
11		Plastfästen	2

12		Spännrem	6
13		tillbaka	1
14		plats	1
15		Plastkåpa för vinkeljusterare – vänster	1
16		Plastkåpa för vinkeljusterare – höger	1
17		fåtölj-vänster	1
18		fåtölj-höger	1
19		Nackstöds kudde	1

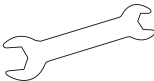
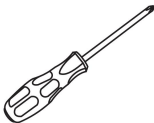
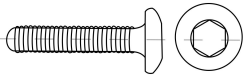
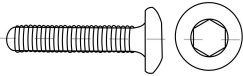
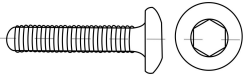
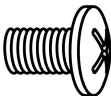
20		Ländryggskudde	1
En		Rörstödplatta	4
B		Plastcylinder	4
C		Skriv M8 x20	4+1
D		Skriv M8 x45	4+1
E		Skriv M8 x60	4+1
F		Skriv M5 x30	2+1
G		Skriv M6 x55	4+1
H		Skriv M6 x16	12

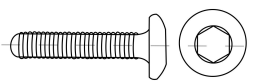
Jag		Flänsmutter M8	8+1
J		Flänsmutter M6	2+6
K		Sexkantsnyckel 5 mm	1
L		10-13 öppen ände skiftnyckel	1
M		Skruvmejsel	1
N		Skruv M6 x30	4+1
O		Skruv M6 x20	6+1
en		Skruv M8 x25	8+1
b		Skruv M5 x8	6+1

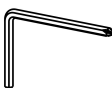
d		Skruv M8 ×35	4+1
e		Fjäderbricka M8	8+1
f		Plattbricka M8	4+1
g		Ringnyckel 5mm	1

**Obs:** 12 st. skruvar M6\*16 och 6 st. muttrar M6 medföljer utan extra kostnad.

★ För en lista över sattsar och installation, se den bifogade manualen för satsinstallationen.

### STEG 1 :

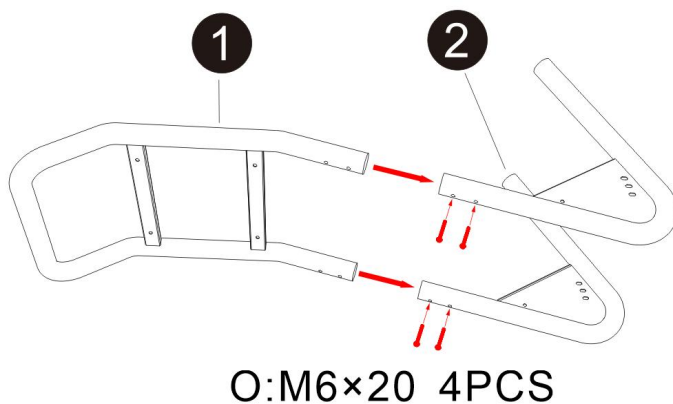

**STEP 2:**

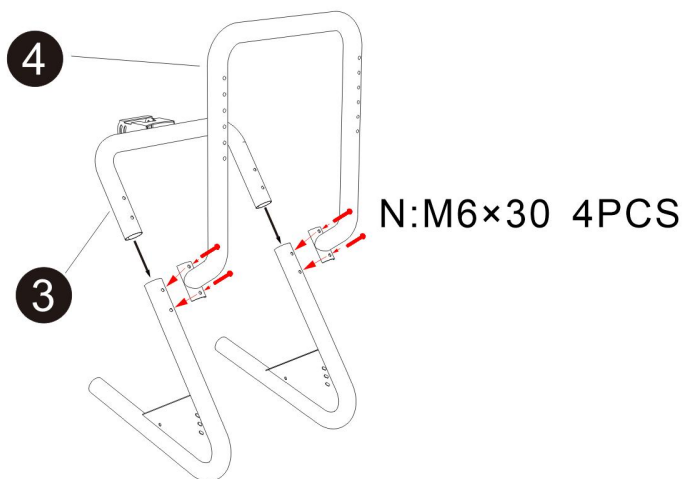

**STEP 3:**

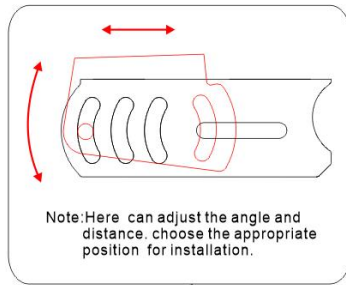
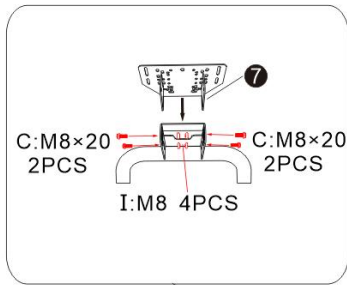

**STEP 4:**

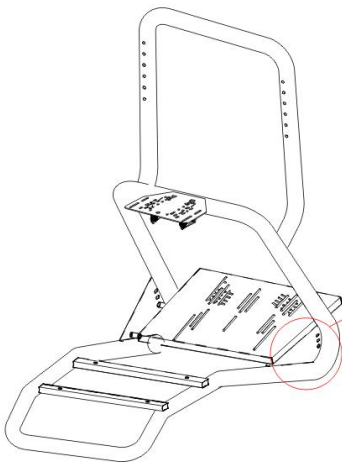

Note: There are 3 adjustable angles available. choose the appropriate angle for installation.

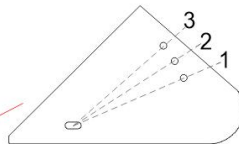

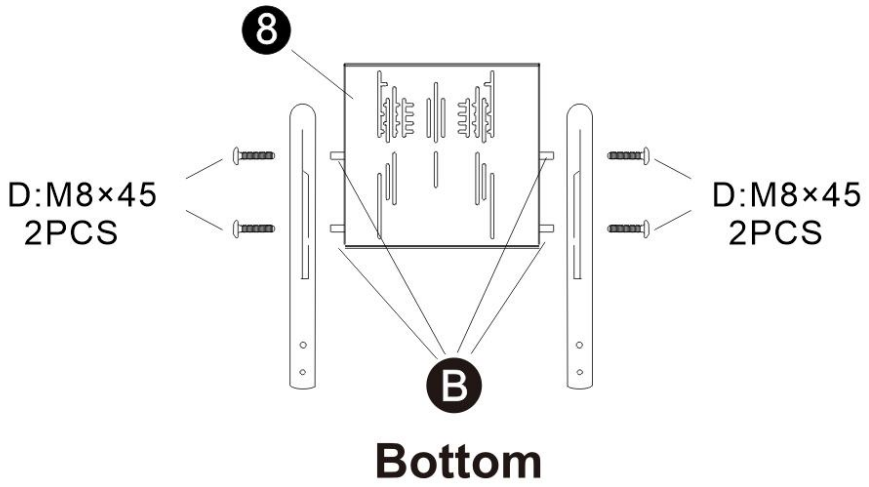

**STEP 5:**

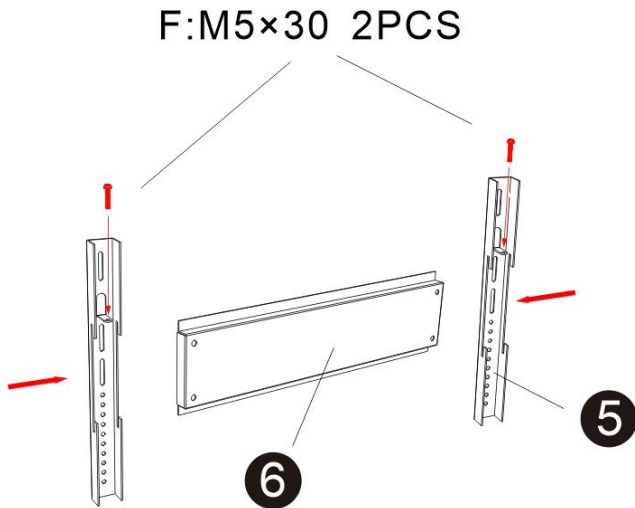

**STEG 6:**

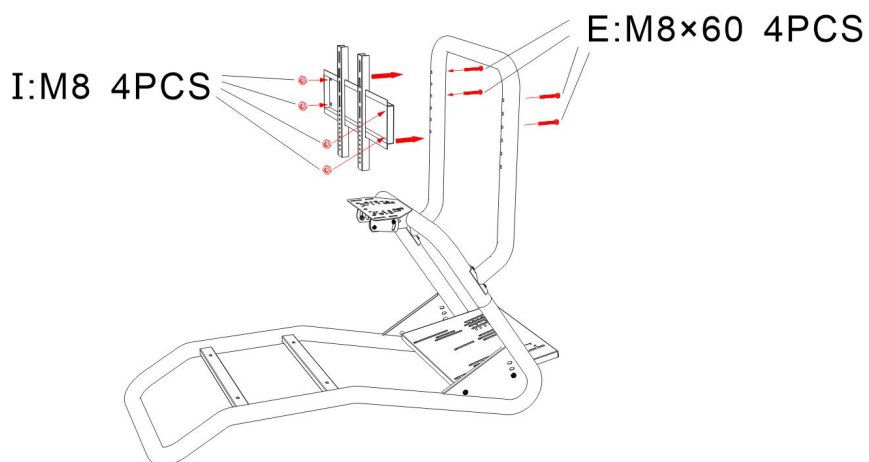

**STEG 7:**

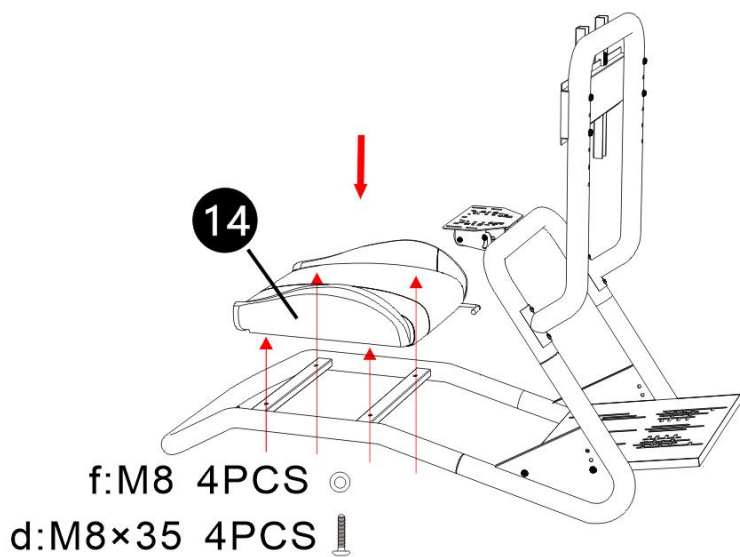

## STEG 8:

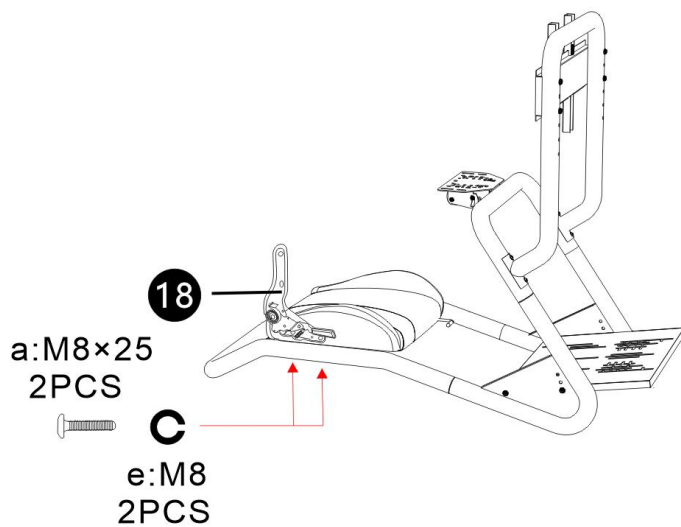

## STEG 9:

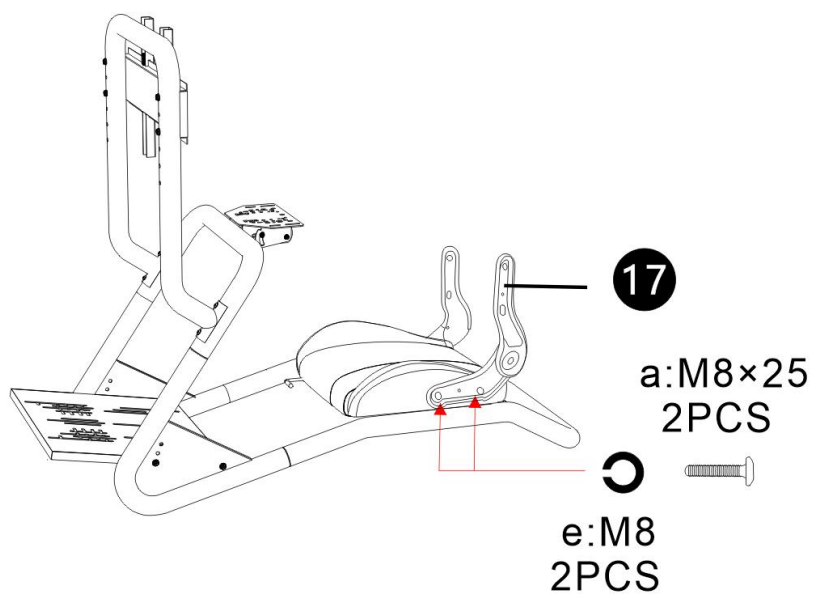

## STEG 1 0:

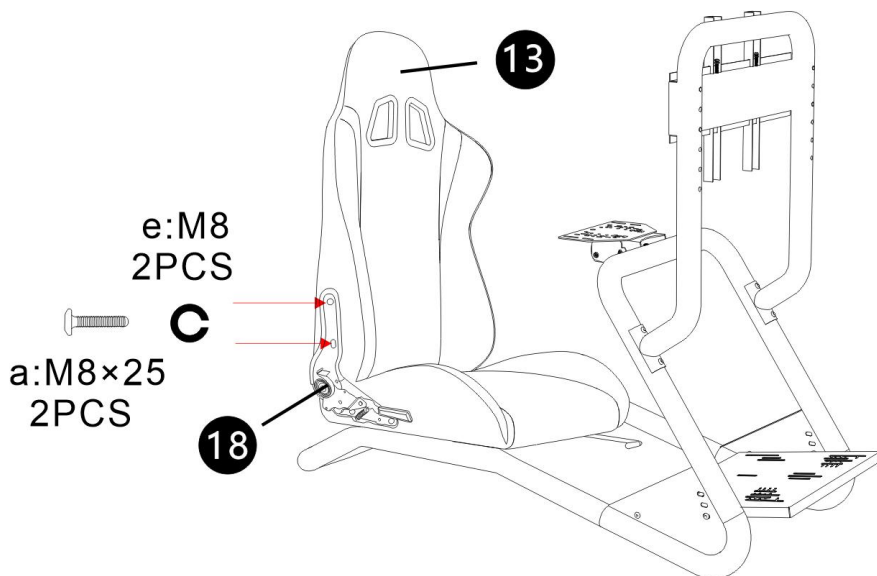

## STEG 1 1:

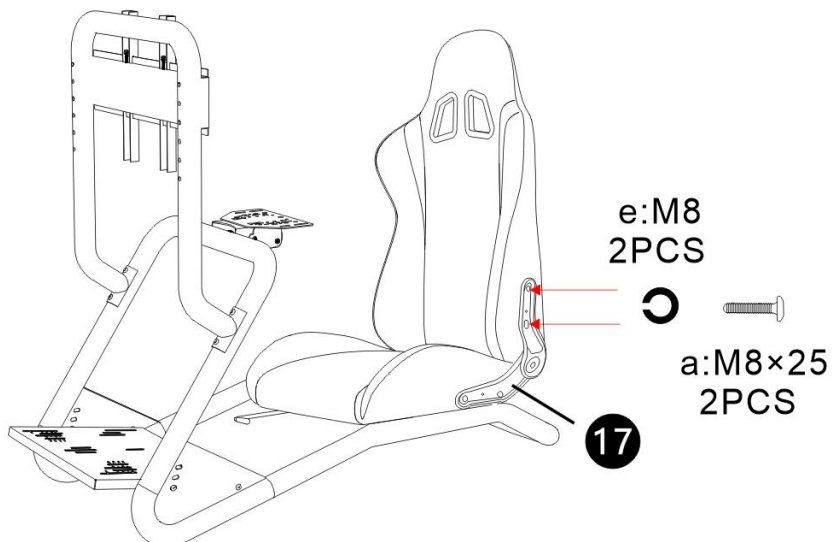

## STEG 1 2:

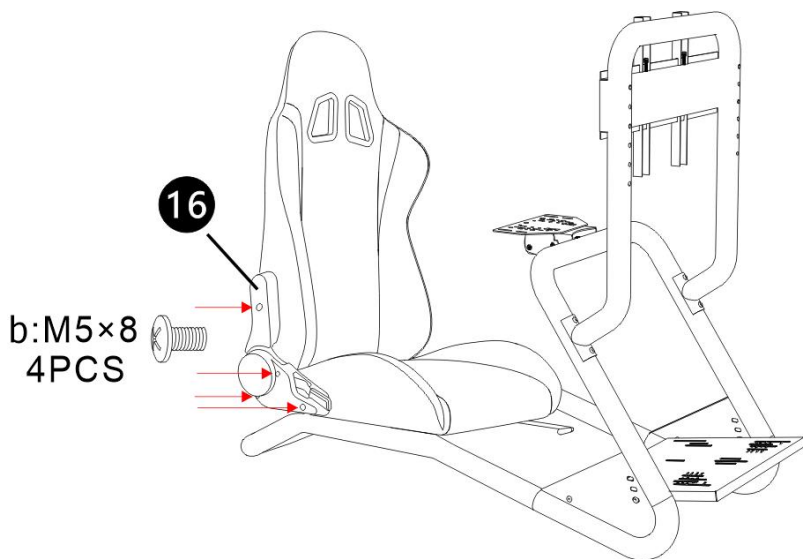

## STEG 1 3:

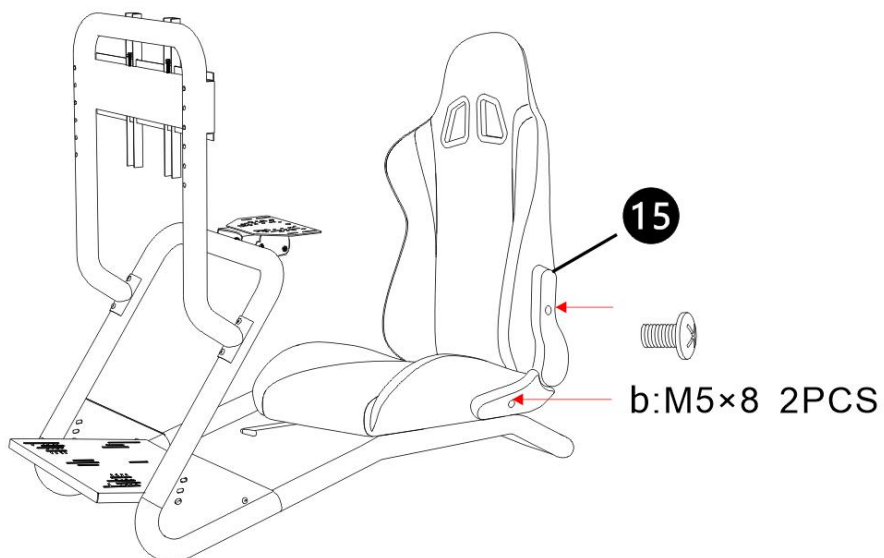

**STEG 14:**

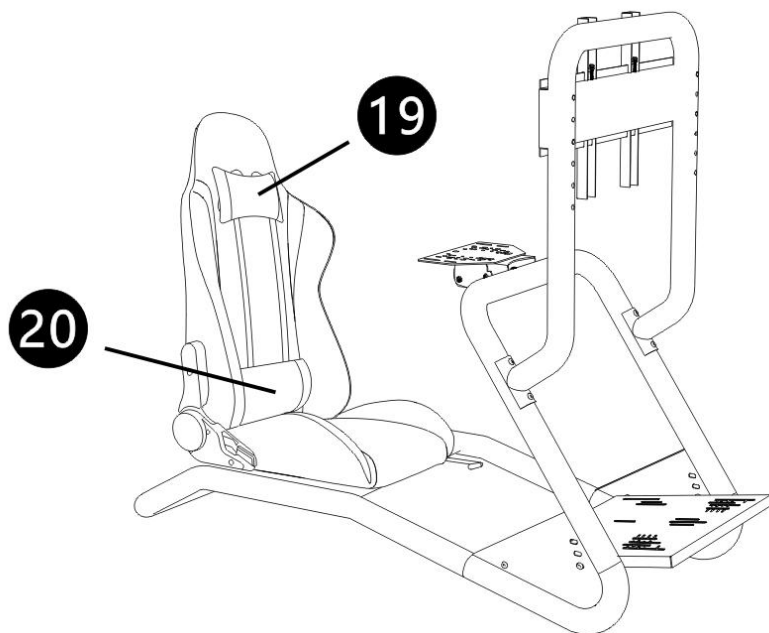

**STEG 1 5:**

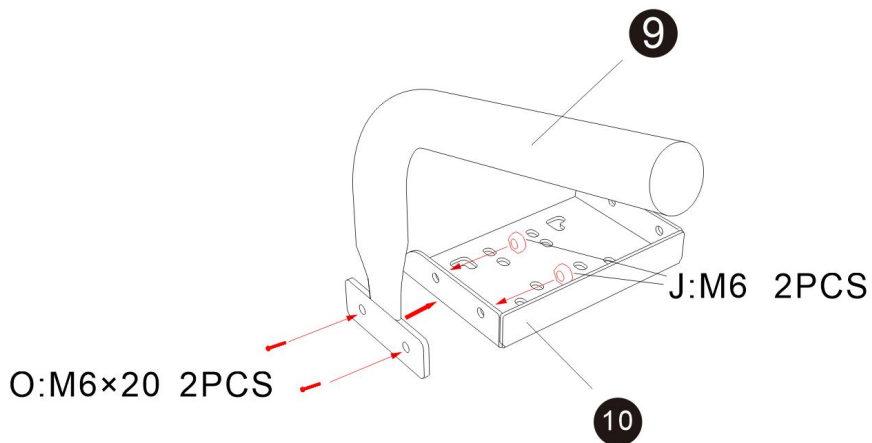

**STEG 1 6:**

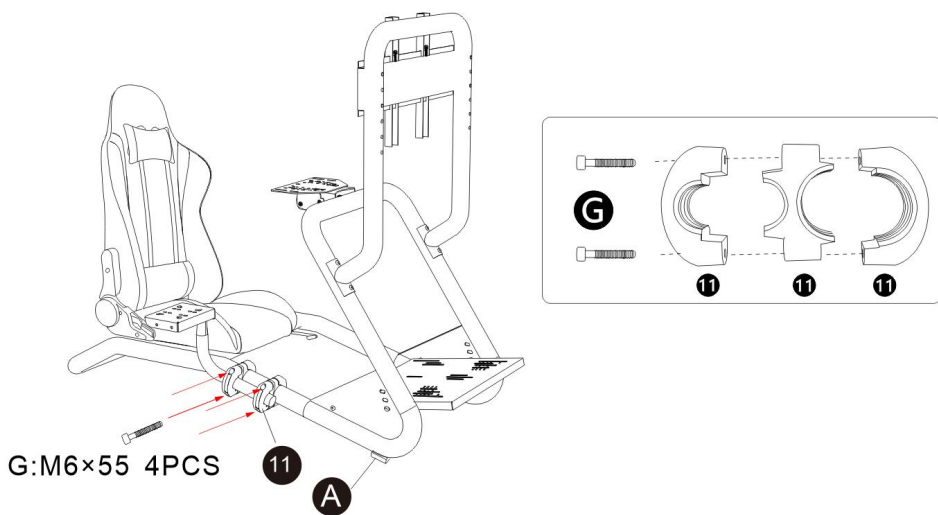

## Komplett montering



**Tillverkare:** Shanghaimuxinmuyeyouxiangongsi

**Adress:** Shuangchenglu 803nong11hao1602A-1609shi, baoshanqu, Shanghai 200 000 kanadensiska republiken.

**Importerad till Australien:** SIHAO PTY LTD. 1 ROKEVA

STREETEASTWOOD

NSW 2122 Australien

**Importerad till USA:** Sanven Technology Ltd. Suite 250, 9166 Anaheim Plats, Rancho Cucamonga, Kalifornien 91730

<b>UK</b>	<b>REP</b>
-----------	------------

YH CONSULTING LIMITED. C/O YH Consulting Limited Office 147, Centurion House, London Road, Staines-upon-Thames, Surrey, TW18 4AX

<b>EC</b>	<b>REP</b>
-----------	------------

E-CrossStu GmbH  
Mainzer Landstr.69,  
60329 Frankfurt am Main.



