

VEVOR

Affordable. Reliable. Home Improvement.

STEERING WHEEL STAND

MODEL: 6019

VEVOR

Affordable. Reliable. Home Improvement.

STEERING WHEEL STAND

Model:6019

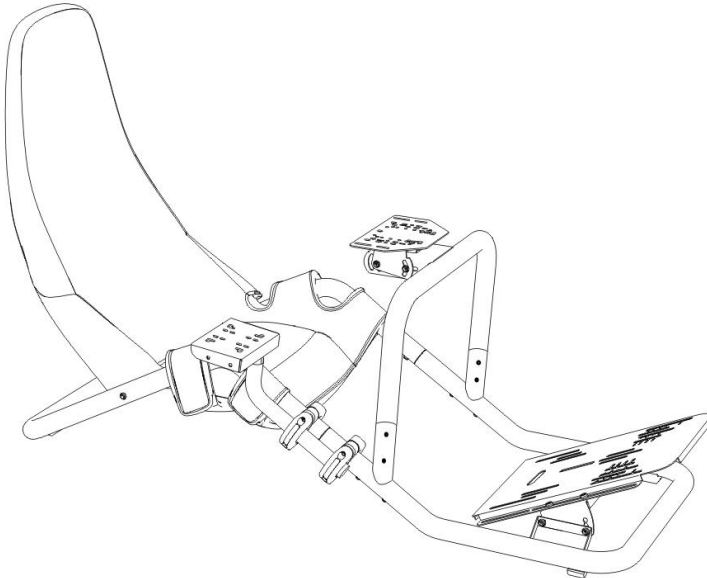

This is the original instruction, please read all manual instructions carefully before operating. VEVOR reserves a clear interpretation of our user manual. The appearance of the product shall be subject to the product you received. Please forgive us that we won't inform you again if there are any technology or software updates on our product.









Warning-To reduce the risk of injury, user must read instructions manual carefully.

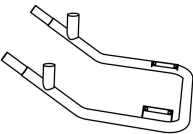



Attentions



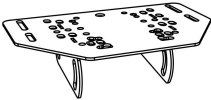
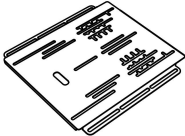
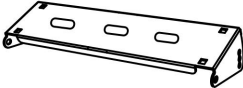
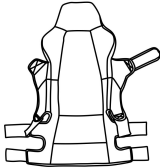
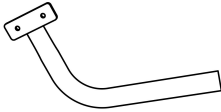
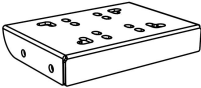

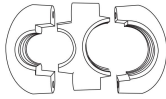
- Please install and use the stand according to instruction.
 - Please install moderately, avoid strong vibration.
 - Don't keep in humid conditions, high temperatures, or a dusty location.
 - The product structure is flexible, wear work gloves during assembly.
- Please take care of a hurting hand when installing .
- Children should be under adult supervision when using the product.

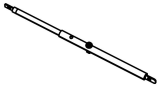
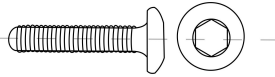
Save the manual.

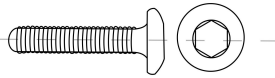
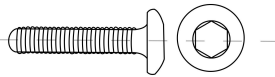
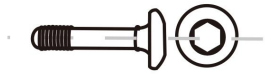
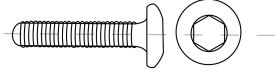
Part List			
Code	Picture	Name	QTY.
1		Pedestal A	1
2		Pedestal B	1
3		U-shaped part	1
4		Back main frame	2
5		Back of head	1

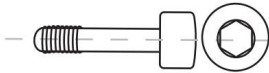
6		Tie-down strap	6
7		Lumbar support belt	1
8		Steering Wheel Panel	1
9		Pedal panel	1
10		Pedal Holder	1
11		Seat cover	1
12		Gear lever holder	1
13		Gear lever panel	1

14		Plastic fasteners	2
15		Pipe Support Pad	4
16		Back adjustment rod	2
A		Screw M6x16	6+12
B		Flat washer M8	4+1
C		Screw M6x35	4+1
D		Screw M6x55	2+1
E		Screw M6x75	2+1
F		Screw M8x20	12+1

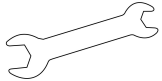
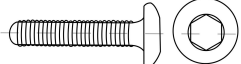
G		Screw M6×55	4+1
H		Flange nut M8	4+1
I		Flange nut M6	14+6
J		Hex wrench 5mm	1
K		open-end Spanner 10-13	1
L		Screw M6×50	4+1

Note:12pcs screws M6*16 and 6pcs nuts M6 are complimentary.

★ For the list of seat kits and installation, please refer to the seat installation procedure manual attachment.

STEP 1:

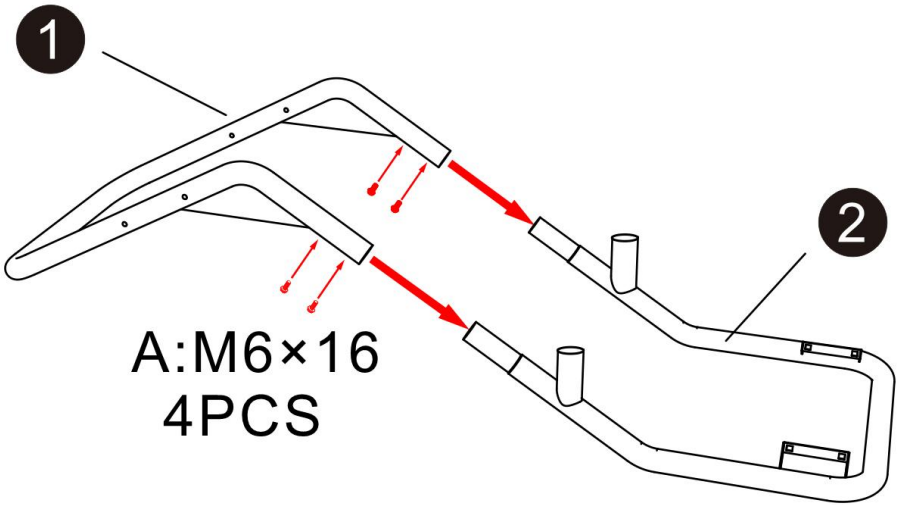

STEP 2:

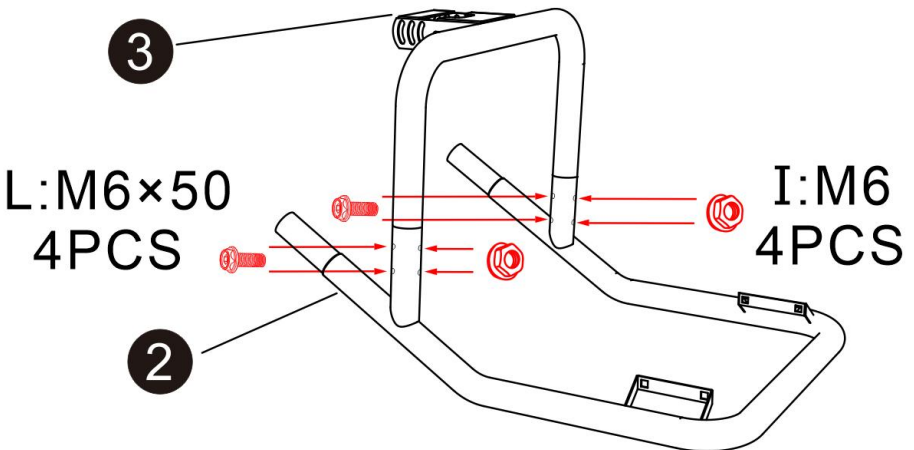

STEP 3:

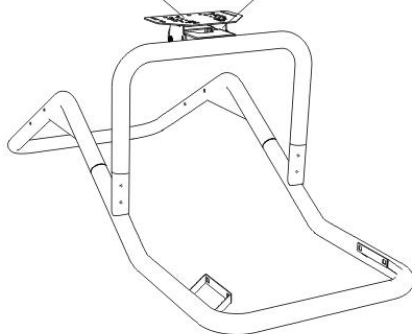
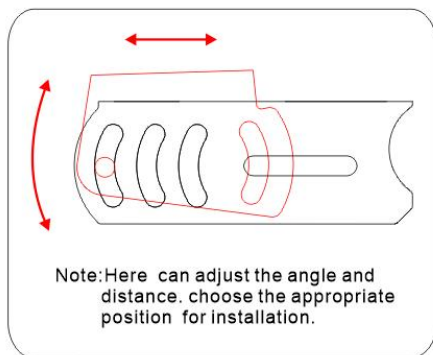
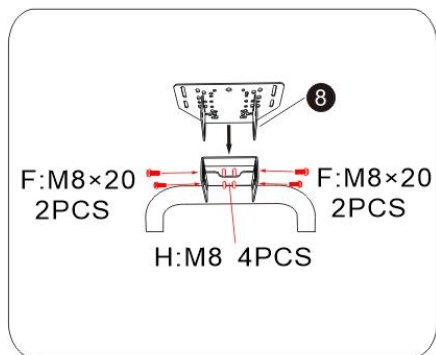

STEP 4:

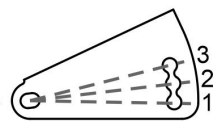
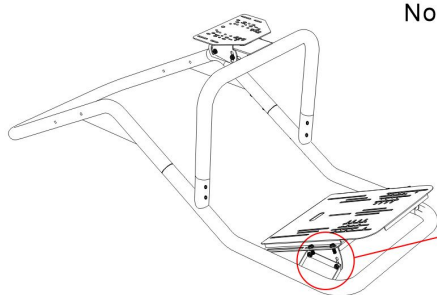

STEP 5:

step5-1

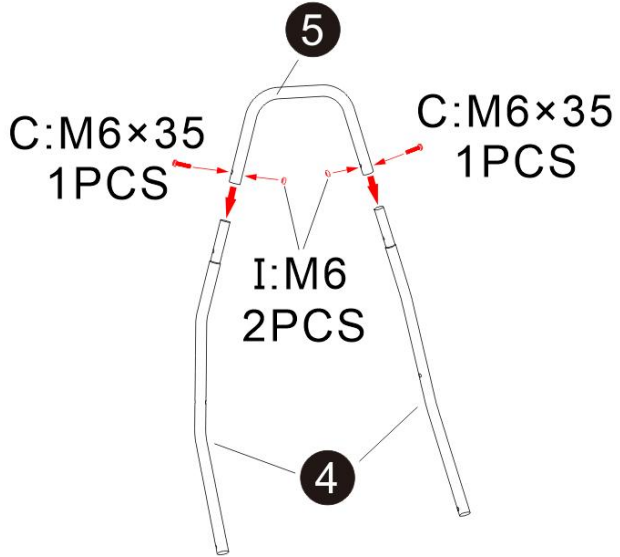

step5-2

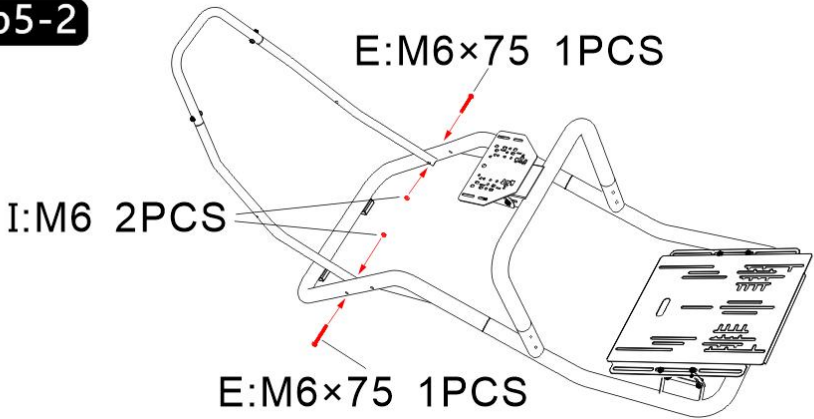

STEP 6:

Note: The pre-installed screws of accessory 16 can be disassembled and reinstalled for adjustment for the backrest angle, choose the appropriate hole position for installation.

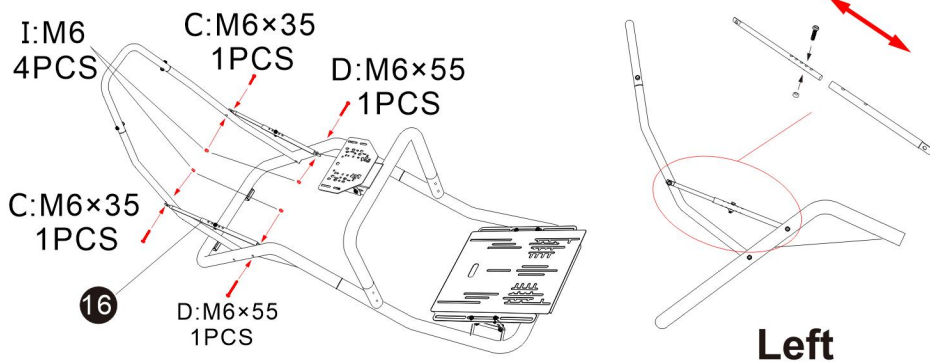

STEP 7:

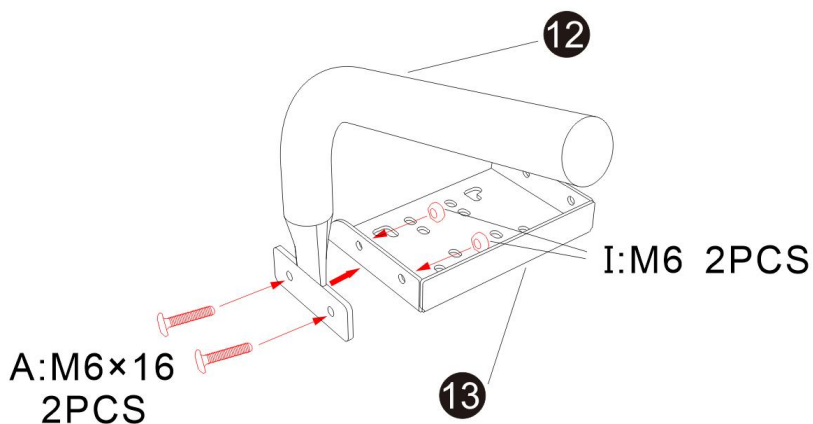

STEP 8:

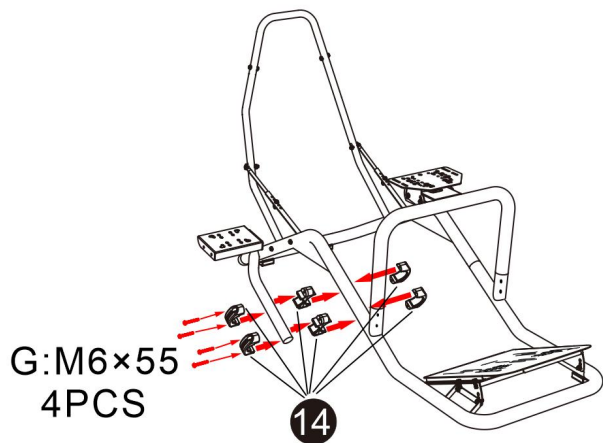

STEP 9:

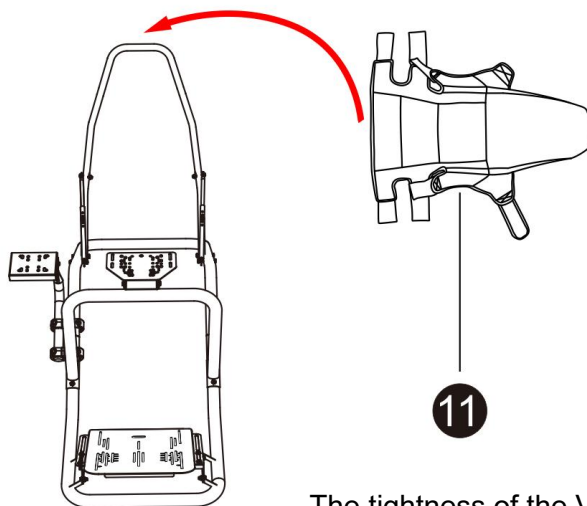

The tightness of the Velcro strap can be adjusted at will

STEP 10:

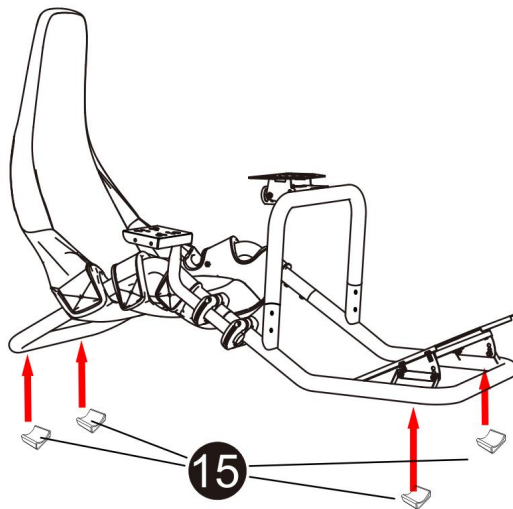

STEP 11:

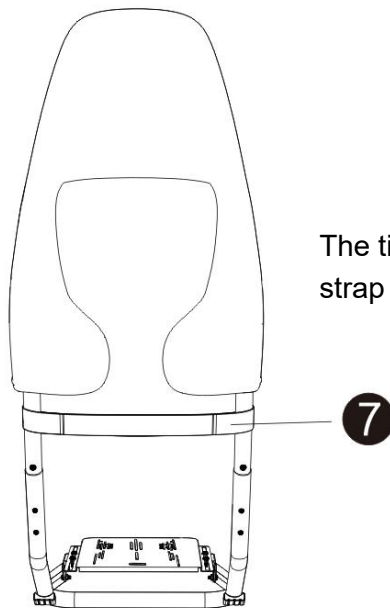

The tightness of the Velcro strap can be adjusted at will

Complete assembly

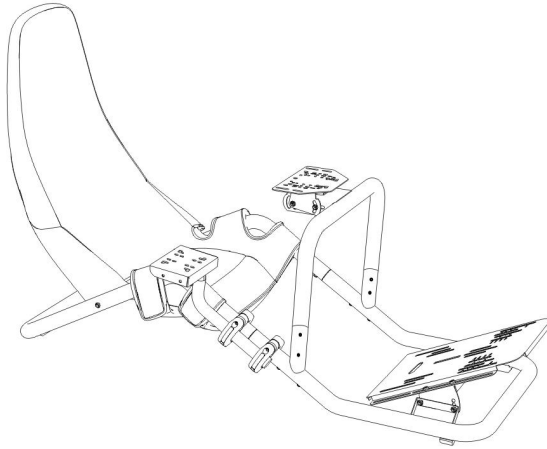

Manufacturer: Shanghaimuxinmuyeyouxiangongsi

Address: Shuangchenglu 803nong11hao1602A-1609shi, baoshanqu, shanghai 200000 CN.

Imported to AUS: SIHAO PTY LTD. 1 ROKEVA STREET EASTWOOD NSW 2122 Australia

Imported to USA: Sanven Technology Ltd. Suite 250, 9166 Anaheim Place, Rancho Cucamonga, CA 91730

UK	REP
-----------	------------

YH CONSULTING LIMITED. C/O YH Consulting Limited Office 147, Centurion House, London Road, Staines-upon-Thames, Surrey, TW18 4AX

EC	REP
-----------	------------

E-CrossStu GmbH
Mainzer Landstr.69,
60329 Frankfurt am Main.



VEVOR

Affordable. Reliable. Home Improvement.

SUPPORT DE VOLANT

MODÈLE: 6019

VEVOR

Affordable. Reliable. Home Improvement.

STEERING WHEEL STAND

Modèle : 6019

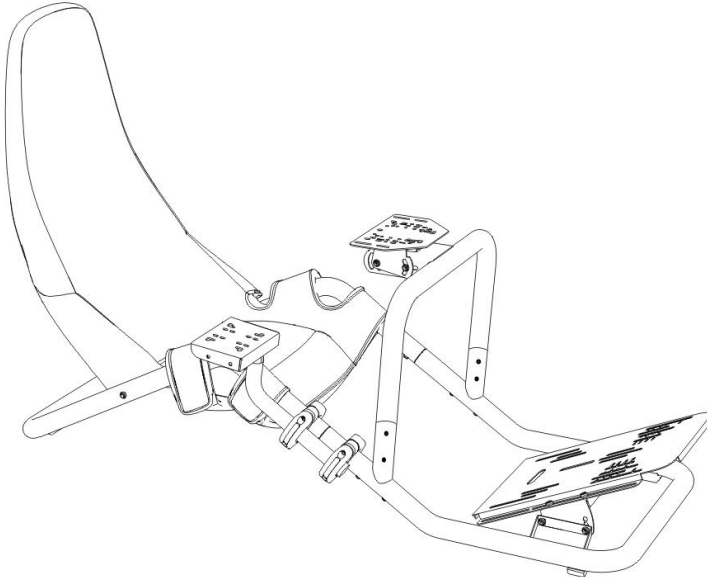

Ceci est le mode d'emploi d'origine. Veuillez lire attentivement l'intégralité du manuel avant utilisation. VEVOR se réserve le droit d'interpréter clairement ce manuel d'utilisation. L'apparence du produit dépend du produit que vous avez reçu. Veuillez nous excuser pour les éventuelles mises à jour technologiques ou logicielles.







Avertissement - Pour réduire le risque de blessure, l'utilisateur doit lire attentivement le manuel d'instructions.



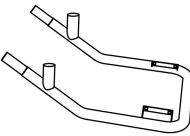

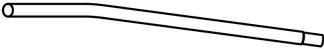

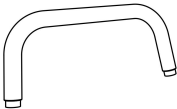
Attention

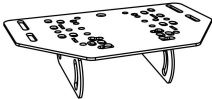
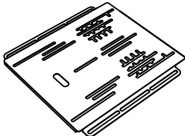
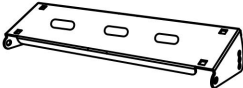
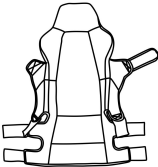
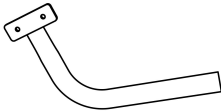

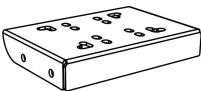
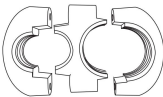

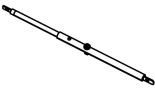
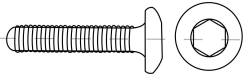
- Veuillez installer et utiliser le support conformément aux instructions .
- Veuillez installer modérément, évitez les fortes vibrations .
- Ne pas conserver dans des conditions humides, à des températures élevées ou dans un endroit poussiéreux .
- La structure du produit est flexible. Portez des gants de travail lors de l'assemblage. Attention aux mains blessées lors de l'installation.
- Les enfants doivent être sous la surveillance d'un adulte lorsqu'ils utilisent le produit.

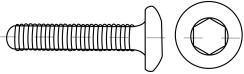
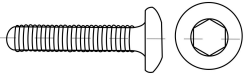
Conservez le manuel.

Liste des pièces			
Code	Image	Nom	Qté.
1		Piédestal A	1
2		Piédestal B	1
3		pièce en forme de U	1
4		Cadre principal arrière	2

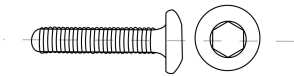
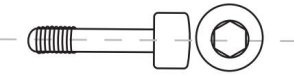
5		Arrière de la tête	1
6		Sangle d'arrimage	6
7		Ceinture de soutien lombaire	1
8		Panneau de volant	1
9		Panneau de pédale	1
10		Support de pédale	1
11		Housse de siège	1
12		Support de levier de vitesses	1

13		Panneau de levier de vitesses	1
14		attaches en plastique	2
15		Coussin de support de tuyau	4
16		Tige de réglage du dossier	2
UN		Vis M 6×16	6 + 12
B		Rondelle plate M8	4 +1
C		Vis M 6×35	4+1
D		Vis M 6×55	2+1
E		Vis M 6×75	2+1

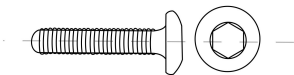
F		Vis M 8×20	12+1
G		Vis M 6×55	4+1
H		Écrou à bride M8	4+1
je		Écrou à bride M6	1 4 +6
J		Clé hexagonale 5 mm	1
K		ouvert Clé 10-13	1
L		Vis M 6 × 50	4 +1

Remarque : 12 vis M6*16 et 6 écrous M6 sont gratuits.

★ Pour la liste des kits de siège et l'installation, veuillez vous référer au manuel de procédure d'installation du siège en pièce jointe.

ÉTAPE 1 :

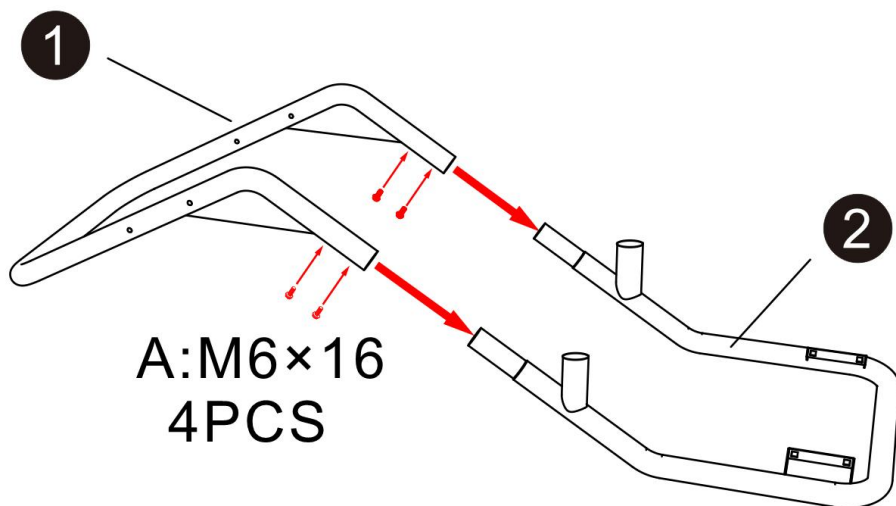

ÉTAPE 2 :

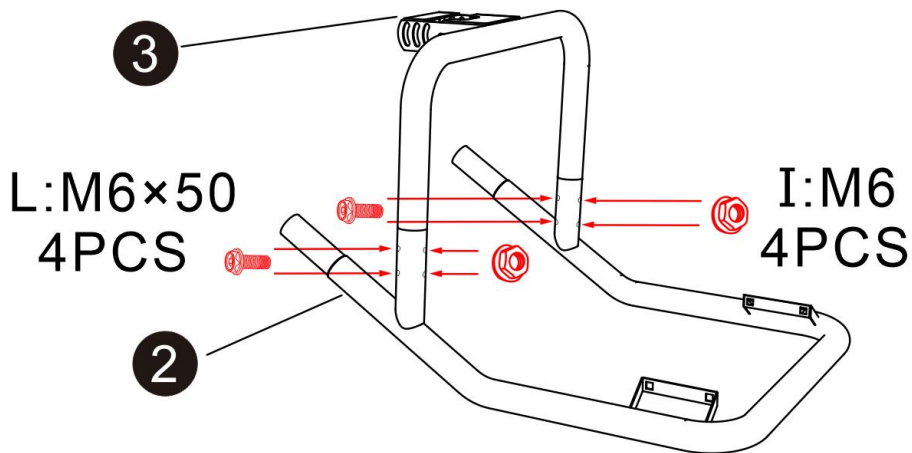

ÉTAPE 3 :

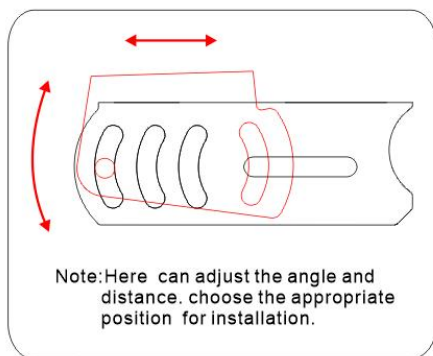
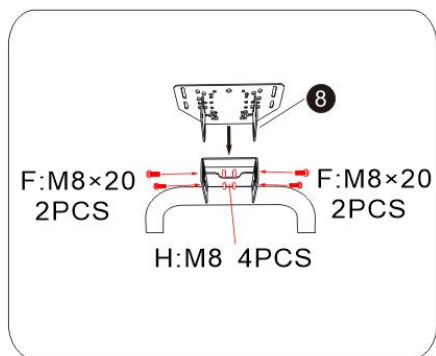

ÉTAPE 4 :

Note: These 3 holes are used to adjust the angle of pedal panel. choose the appropriate hole position for installation.

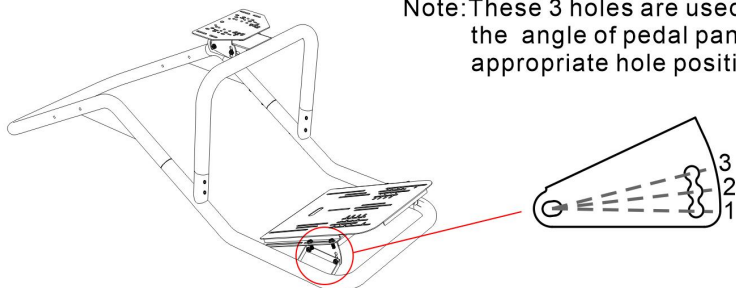

step4-1

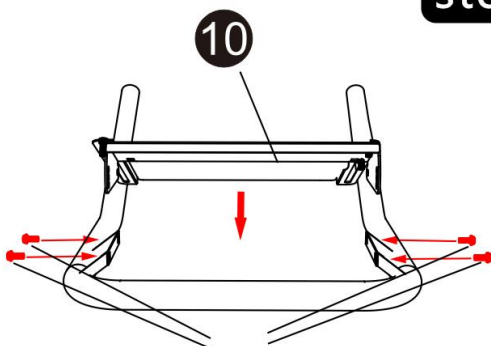

F: M8×20
4PCS

step4-2

F:M8×20 4PCS

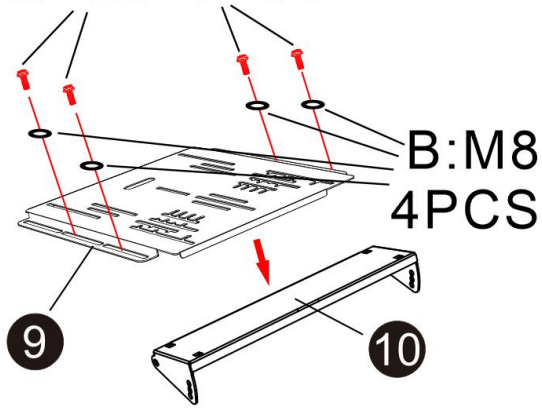

ÉTAPE 5 :

step5-1

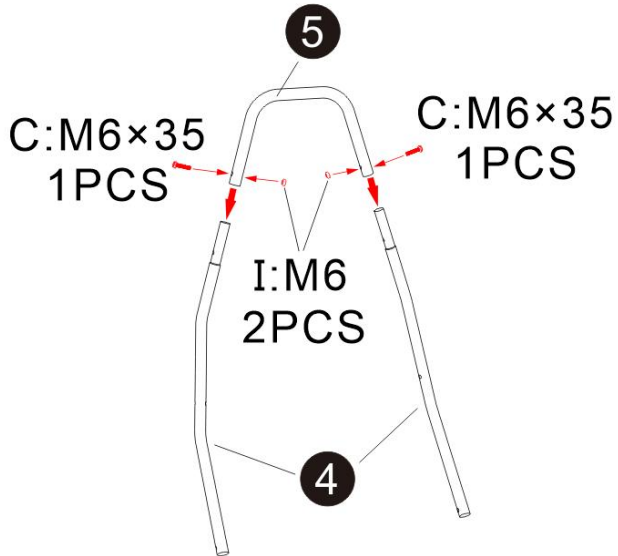

step5-2

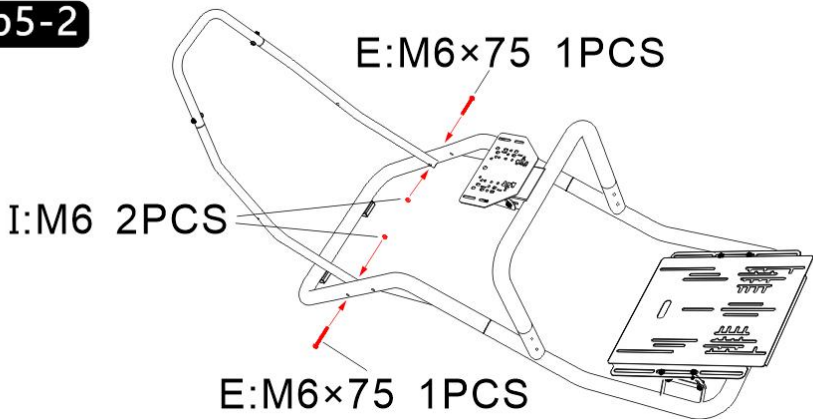

ÉTAPE 6 :

Note: The pre-installed screws of accessory 16 can be disassembled and reinstalled for adjustment for the backrest angle, choose the appropriate hole position for installation.

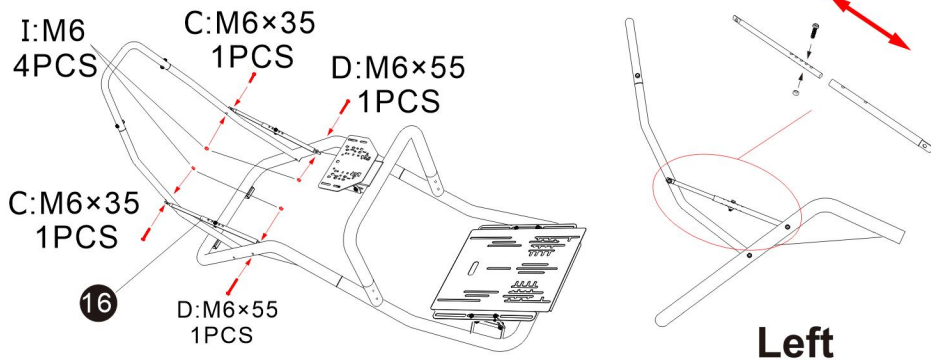

ÉTAPE 7 :

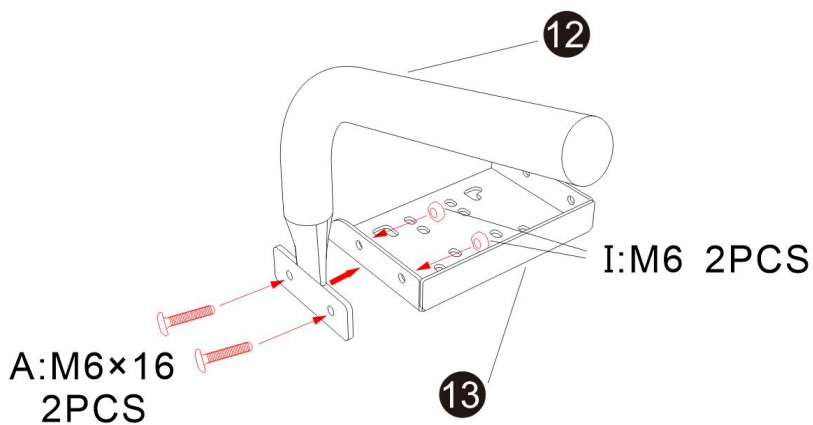

ÉTAPE 8 :

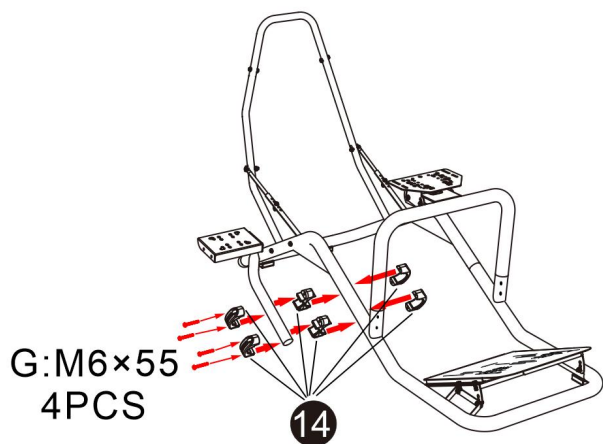

ÉTAPE 9 :

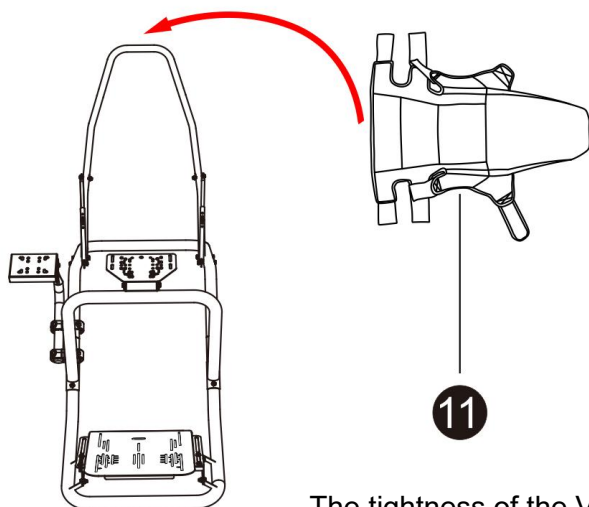

The tightness of the Velcro strap can be adjusted at will

ÉTAPE 10 :

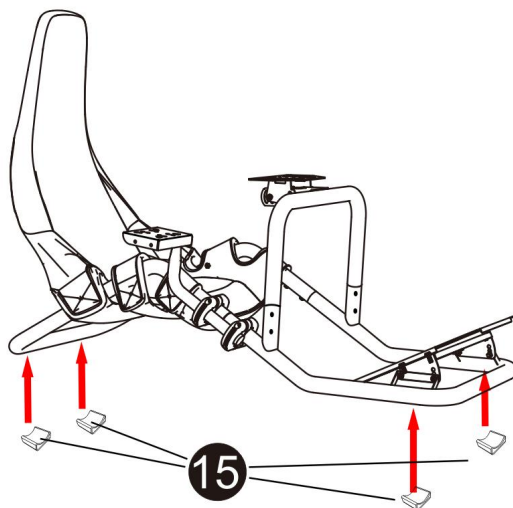

ÉTAPE 1 1:

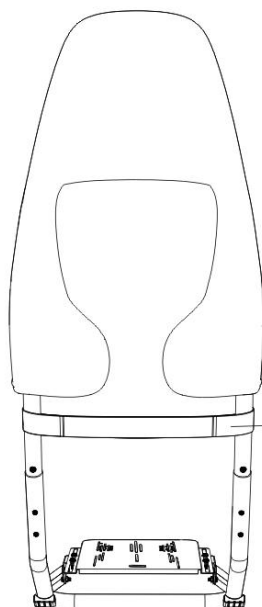

The tightness of the Velcro strap can be adjusted at will

Assemblage complet

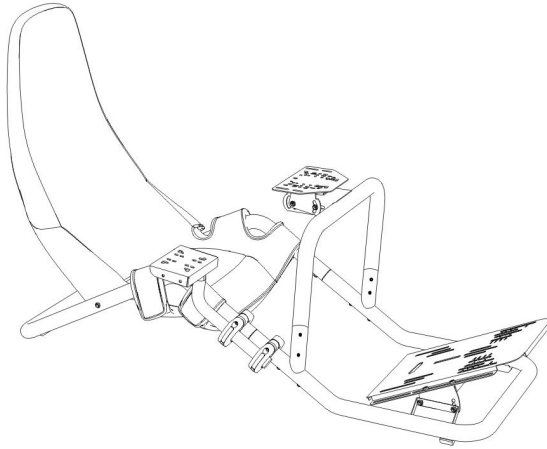

Fabricant : Shanghaimuxinmuyeyouxiangongsi

Adresse : Shuangchenglu 803nong11hao1602A-1609shi, baoshanqu, Shanghai 200 000 CN.

Importé en Australie : SIHAO PTY LTD. 1 ROKEVA STREET, ASTWOOD NSW 2122 Australie

Importé aux États-Unis : Sanven Technology Ltd. Suite 250, 9166 Anaheim

Lieu, Rancho Cucamonga, CA 91730

UK	REP
-----------	------------

YH CONSULTING LIMITED. C/O YH Consulting Limited Office 147, Centurion House, London Road, Staines-upon-Thames, Surrey, TW18 4AX

EC	REP
-----------	------------

E-CrossStu GmbH
Mainzer Landstr.69,
60329 Frankfurt am Main.



VEVOR

Affordable. Reliable. Home Improvement.

LENKRADSTÄNDER

MODELL: 6019

Modell: 6019

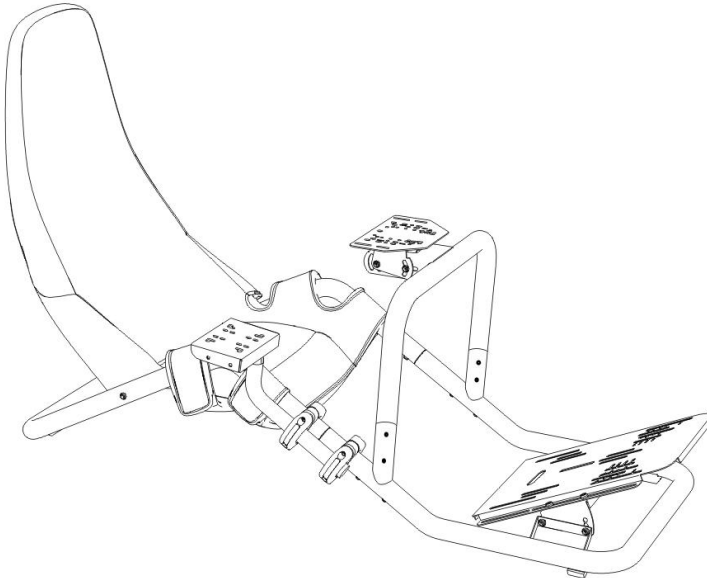

Dies ist die Originalanleitung. Bitte lesen Sie alle Anweisungen sorgfältig durch, bevor Sie das Gerät in Betrieb nehmen. VEVOR behält sich eine klare Auslegung unserer Bedienungsanleitung vor. Das Aussehen des Produkts hängt vom gelieferten Produkt ab. Bitte haben Sie Verständnis dafür, dass wir Sie nicht erneut über Technologie- oder Software-Updates informieren.







Warnung: Um das Verletzungsrisiko zu verringern, muss der Benutzer die Bedienungsanleitung sorgfältig lesen.



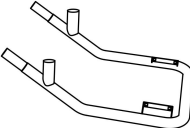

Aufmerksamkeiten

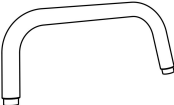
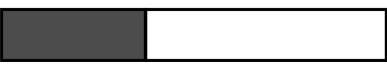

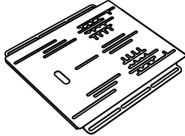
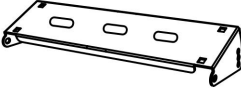
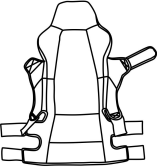

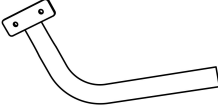
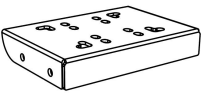
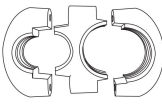
- Bitte installieren und verwenden Sie den Ständer gemäß der Anleitung .
- Bitte maßvoll installieren, starke Vibrationen vermeiden .
- Nicht in feuchter Umgebung, bei hohen Temperaturen oder an einem staubigen Ort aufbewahren .
- Die Produktstruktur ist flexibel. Tragen Sie bei der Montage Arbeitshandschuhe. Achten Sie bei der Installation darauf, dass Ihre Hände nicht verletzen.
- Kinder sollten bei der Verwendung des Produkts unter Aufsicht von Erwachsenen stehen.

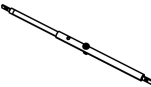
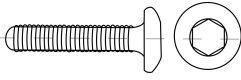
Bewahren Sie das Handbuch auf.

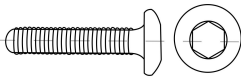
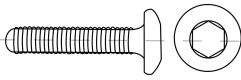
Teilleiste			
Code	Bild	Name	MENGE.
1		Sockel A	1
2		Sockel B	1
3		U-förmiges Teil	1

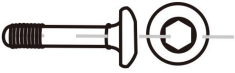
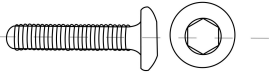
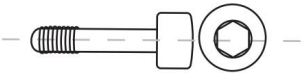
4		Hinterer Hauptrahmen	2
5		Hinterkopf	1
6		Zurrgurt	6
7		Lordosenstützgür- tel	1
8		Lenkradverkleidu- ng	1
9		Pedalplatte	1
10		Pedalhalterung	1
11		Sitzbezug	1

12		Schalthebelhalter	1
13		Schalthebelverkleidung	1
14		Kunststoffverschlüsse	2
15		Rohrstützpolster	4
16		Rückenverstellstange	2
A		Schraube M 6×16	6 +12
B		Unterlegscheibe M8	4 +1
C		Schraube M 6×35	4+1
D		Schraube M 6×55	2+1

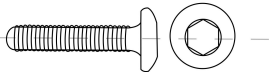
E		Schraube M 6×75	2+1
F		Schraube M 8×20	12+1
G		Schraube M 6×55	4+1
H		Flanschmutter M8	4+1
ICH		Flanschmutter M6	1 4 +6
J		Sechskantschlüs sel 5mm	1
K		offenes Ende Schraubenschlüs sel 10-13	1
L		Schraube M 6 × 50	4 +1

Hinweis: 12 Schrauben M6*16 und 6 Muttern M6 sind im Lieferumfang enthalten.

★ Eine Liste der Sitzbausätze und der Installation finden Sie im Anhang des Handbuchs zur Sitzinstallation.

SCHRITT 1 :

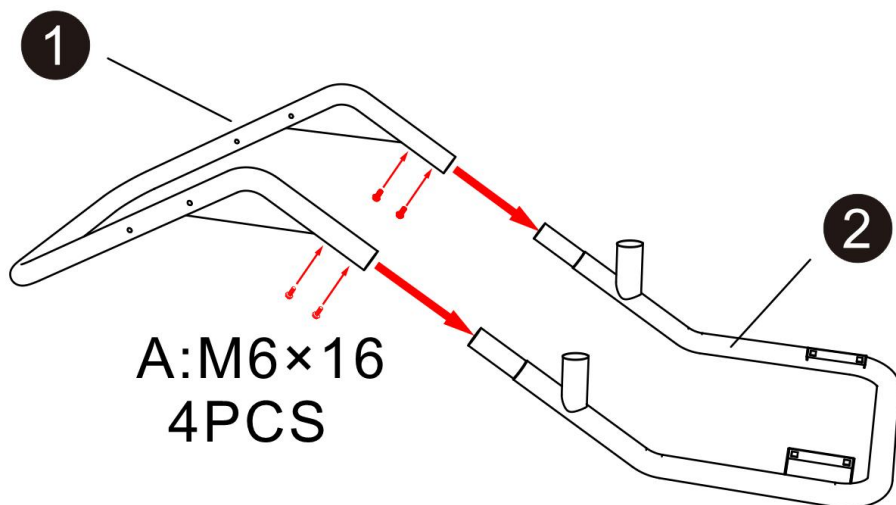

SCHRITT 2:

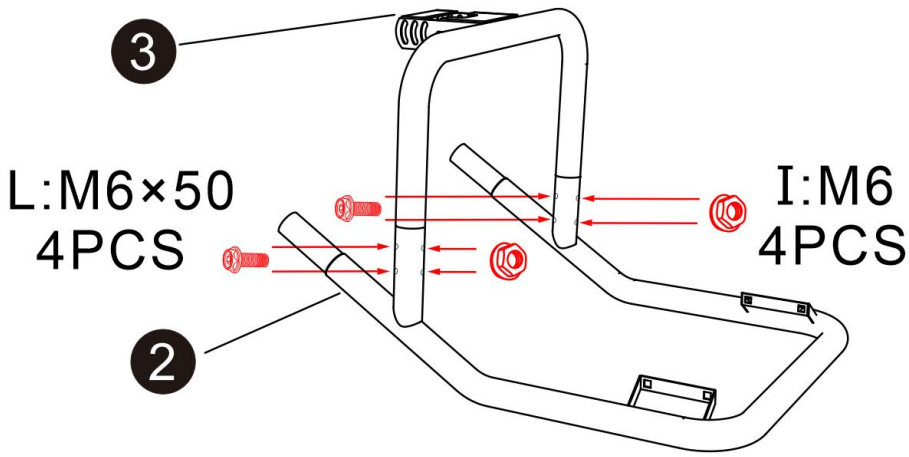

SCHRITT 3:

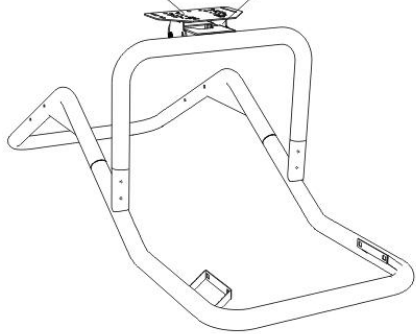
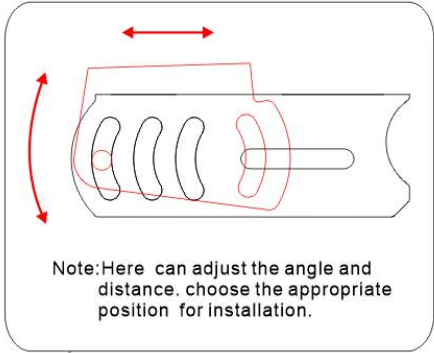
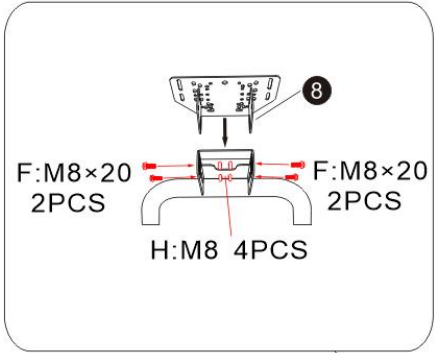

SCHRITT 4:

Note: These 3 holes are used to adjust the angle of pedal panel. choose the appropriate hole position for installation.

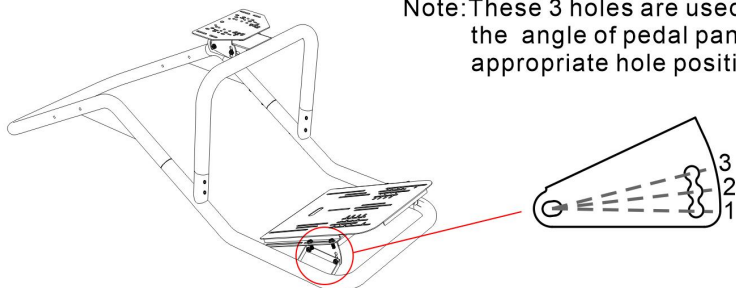

step4-1

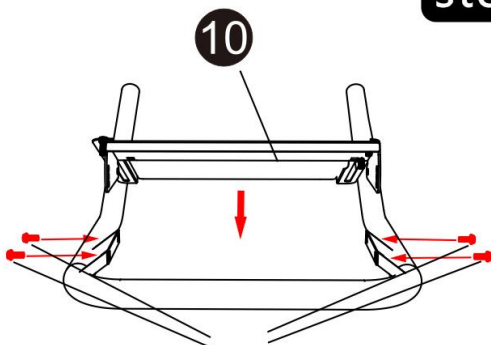

F: M8×20
4PCS

step4-2

F:M8×20 4PCS

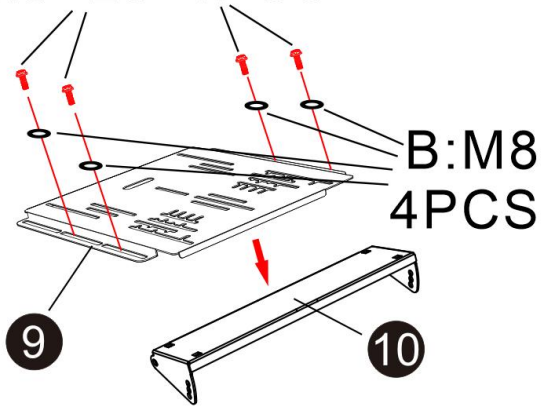

SCHRITT 5:

step5-1

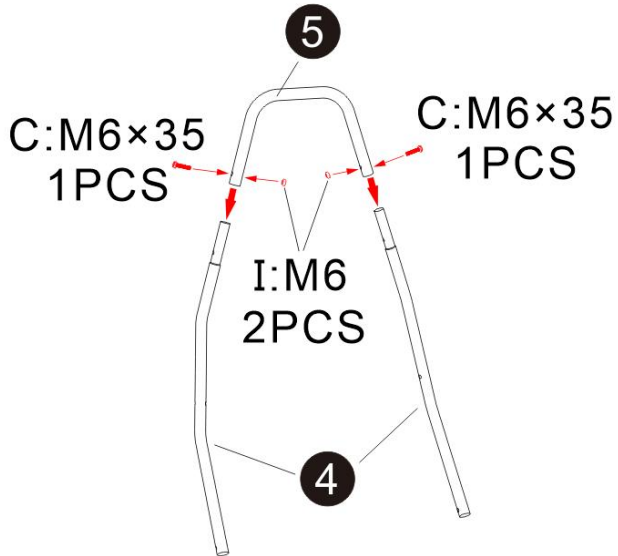

step5-2

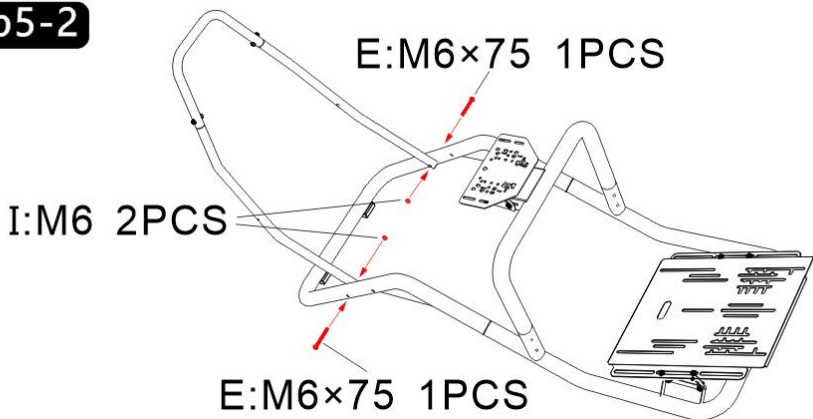

SCHRITT 6:

Note: The pre-installed screws of accessory 16 can be disassembled and reinstalled for adjustment for the backrest angle, choose the appropriate hole position for installation.

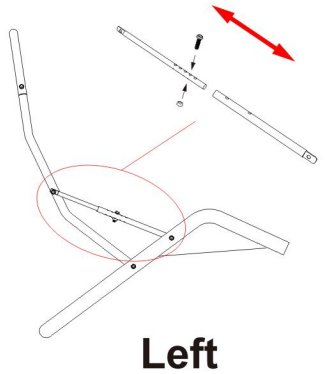
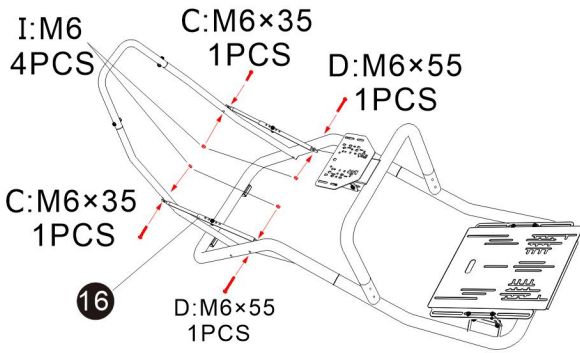

SCHRITT 7:

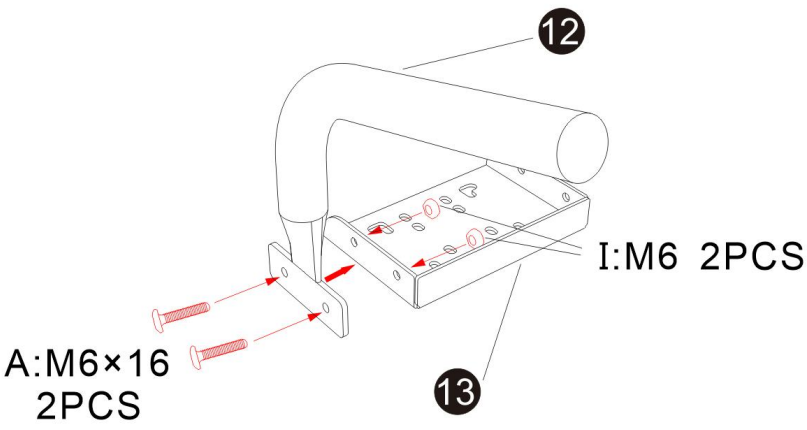

SCHRITT 8:

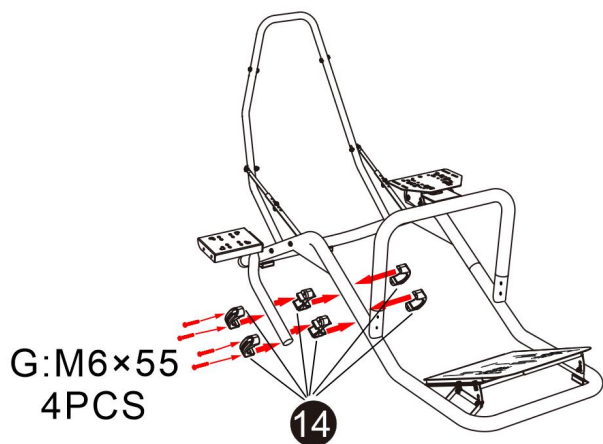

SCHRITT 9:

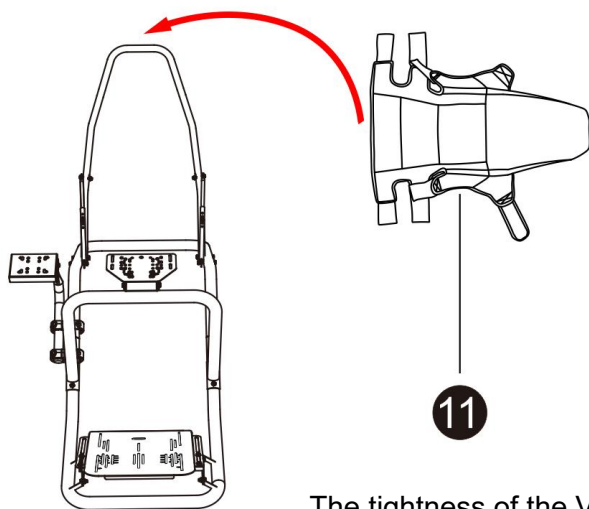

The tightness of the Velcro strap can be adjusted at will

SCHRITT 10:

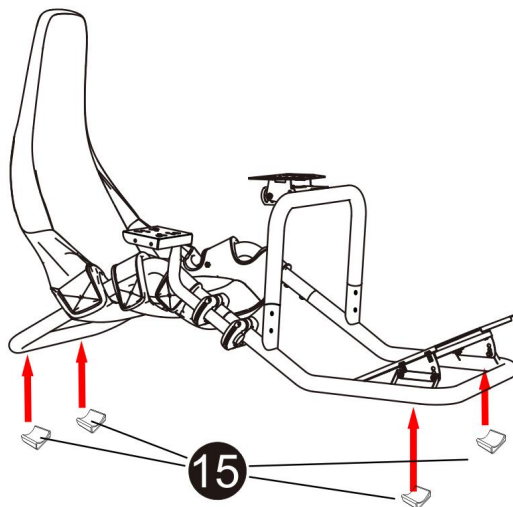

SCHRITT 1 1:

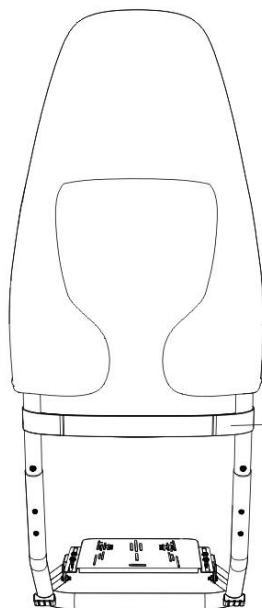

The tightness of the Velcro strap can be adjusted at will

Komplettmontage

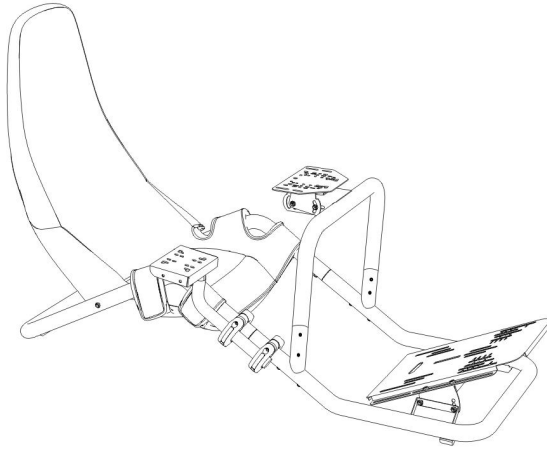

Hersteller: Shanghai muxinmuyeyouxiangongsi

Adresse: Shuangchenglu 803nong11hao1602A-1609shi, baoshanqu, Shanghai 200000 CN.

Importiert nach AUS: SIHAO PTY LTD. 1 ROKEVA STREET EASTWOOD NSW 2122 Australien

Importiert in die USA: Sanven Technology Ltd. Suite 250, 9166 Anaheim Place, Rancho Cucamonga, CA 91730

UK	REP
-----------	------------

YH CONSULTING LIMITED. C/O YH Consulting Limited Office 147, Centurion House, London Road, Staines-upon-Thames, Surrey, TW18 4AX

EC	REP
-----------	------------

E-CrossStu GmbH
Mainzer Landstr.69,
60329 Frankfurt am Main.



VEVOR

Affordable. Reliable. Home Improvement.

SUPPORTO PER VOLANTE

MODELLO: 6019

VEVOR

Affordable. Reliable. Home Improvement.

STEERING WHEEL STAND

Modello: 6019

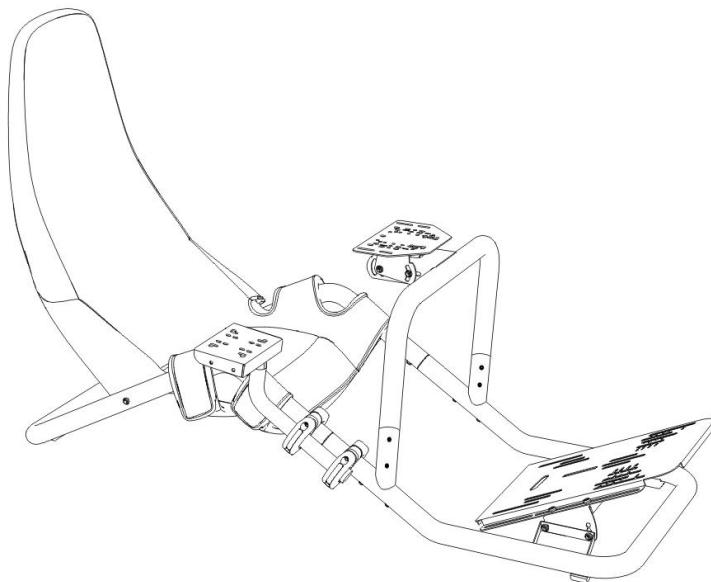

Queste sono le istruzioni originali, si prega di leggere attentamente tutte le istruzioni del manuale prima dell'uso. VEVOR si riserva la piena interpretazione del proprio manuale utente. L'aspetto del prodotto dipenderà dal prodotto ricevuto. Vi preghiamo di scusarci se non vi informeremo più in caso di aggiornamenti tecnologici o software sul nostro prodotto.







Avvertenza: per ridurre il rischio di lesioni, l'utente deve leggere attentamente il manuale di istruzioni.



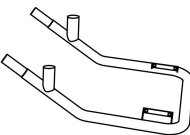

Attenzioni

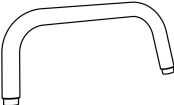
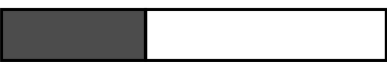

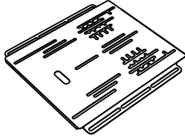
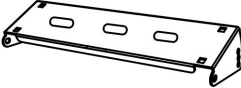
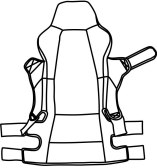

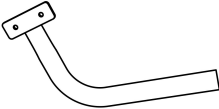
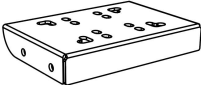
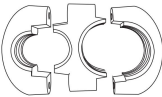
- Installare e utilizzare il supporto seguendo le istruzioni .
- Si prega di installare con moderazione, evitando forti vibrazioni .
- Non conservare in condizioni di umidità, temperature elevate o luoghi polverosi .
- La struttura del prodotto è flessibile, indossare guanti da lavoro durante il montaggio. Fare attenzione a non farsi male alle mani durante l'installazione.
- I bambini devono utilizzare il prodotto sotto la supervisione di un adulto.

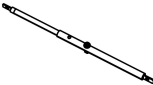
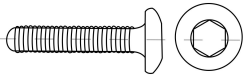
Salva il manuale.

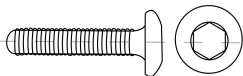
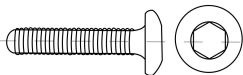
Elenco delle parti			
Codice	Immagine	Nome	QUANTITÀ
1		Piedistallo A	1
2		Piedistallo B	1
3		Parte a forma di U	1

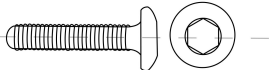
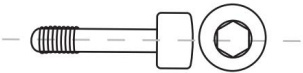
4		Telaio principale posteriore	2
5		Parte posteriore della testa	1
6		Cinghia di ancoraggio	6
7		Cintura di supporto lombare	1
8		Pannello del volante	1
9		Pannello dei pedali	1
10		Supporto per pedale	1
11		Coprisedile	1

12		Supporto leva cambio	1
13		Pannello della leva del cambio	1
14		elementi di fissaggio in plastica	2
15		Supporto per tubi	4
16		Asta di regolazione posteriore	2
UN		Vite M 6x16	6 +12
B		Rondella piana M8	4 +1
C		Vite M 6x35	4+1
D		Vite M 6x55	2+1

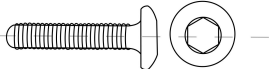
E		Vite M 6×75	2+1
F		Vite M 8×20	12+1
G		Vite M 6×55	4+1
H		Dado flangiato M8	4+1
IO		Dado flangiato M6	1 4 +6
J		Chiave esagonale da 5 mm	1
K		aperto Chiave inglese 10-13	1
L		Vite M 6 × 50	4 +1

Nota: 12 viti M6*16 e 6 dadi M6 sono gratuiti.

★ Per l'elenco dei kit di sedili e l'installazione, fare riferimento al manuale di istruzioni per l'installazione dei sedili allegato.

PASSO 1 :

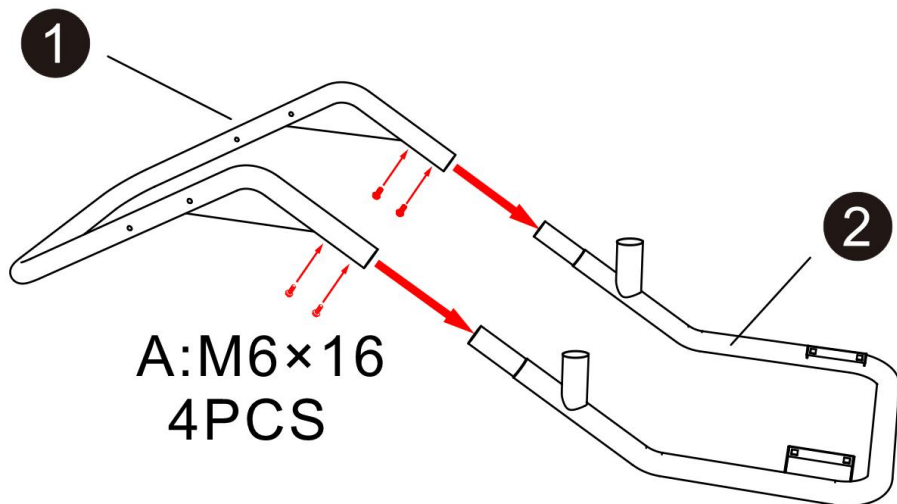

PASSO 2:

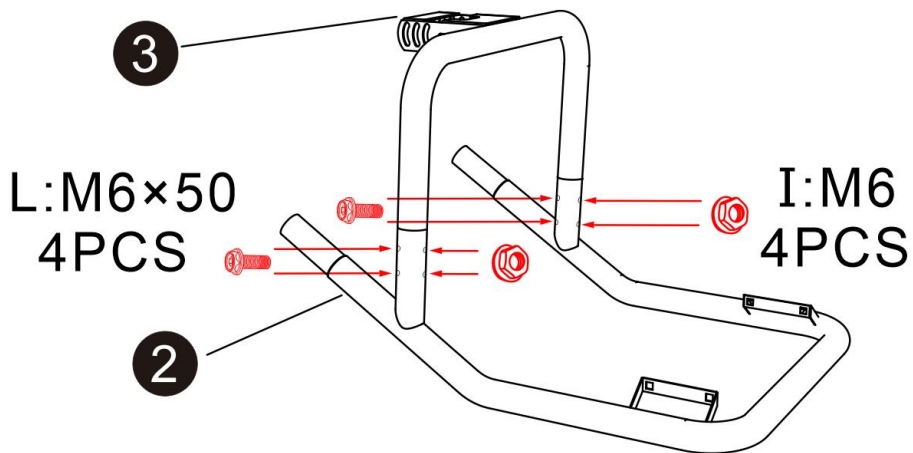

PASSO 3:

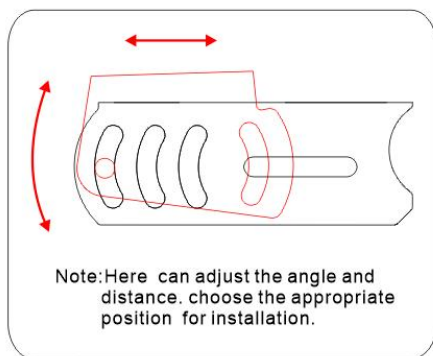
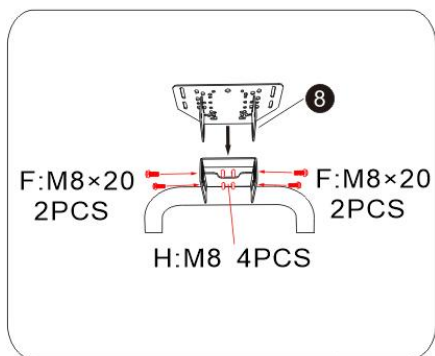

PASSO 4:

Note: These 3 holes are used to adjust the angle of pedal panel. choose the appropriate hole position for installation.

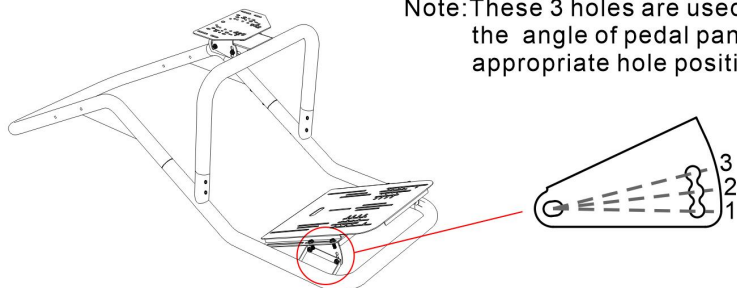

step4-1

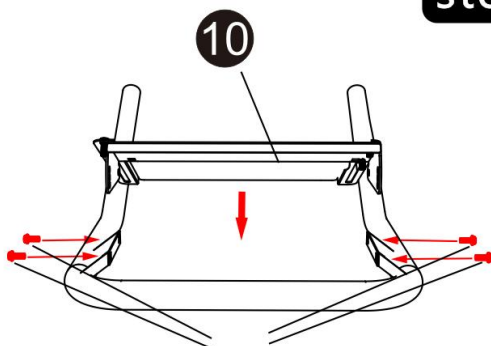

F: M8×20
4PCS

step4-2

F:M8×20 4PCS

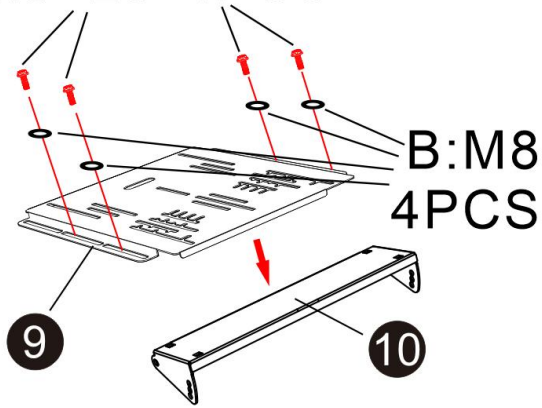

PASSO 5:

step5-1

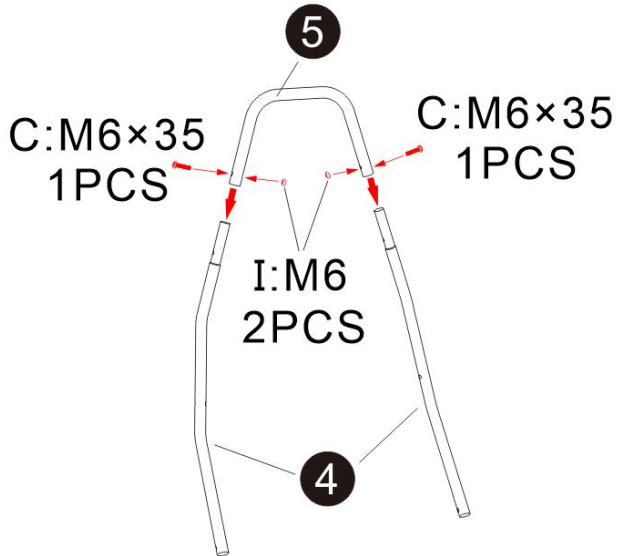

step5-2

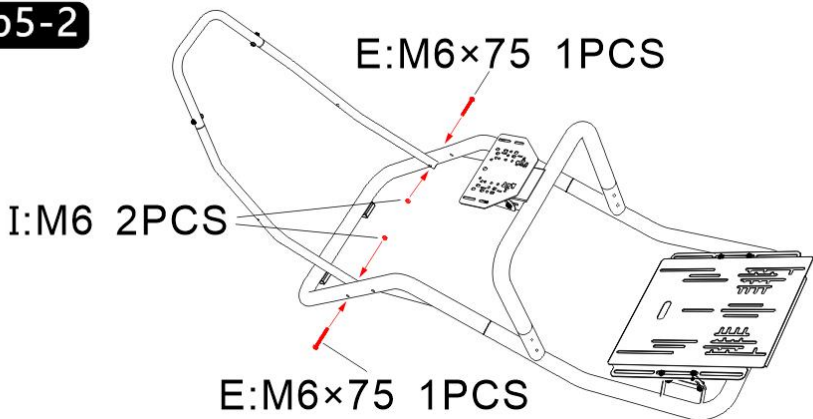

PASSO 6:

Note: The pre-installed screws of accessory 16 can be disassembled and reinstalled for adjustment for the backrest angle, choose the appropriate hole position for installation.

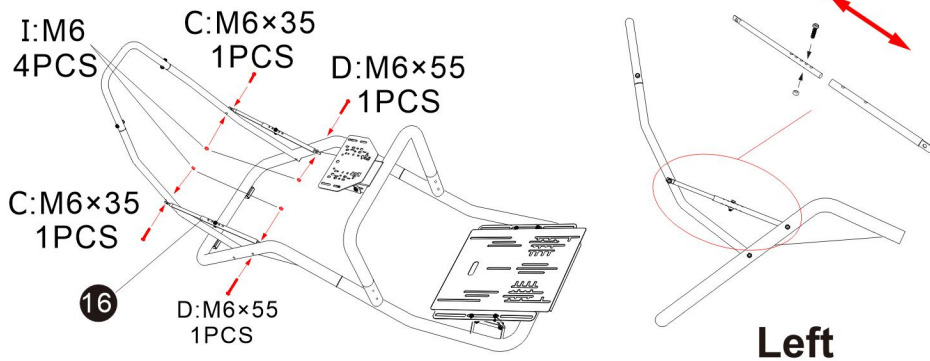

PASSO 7:

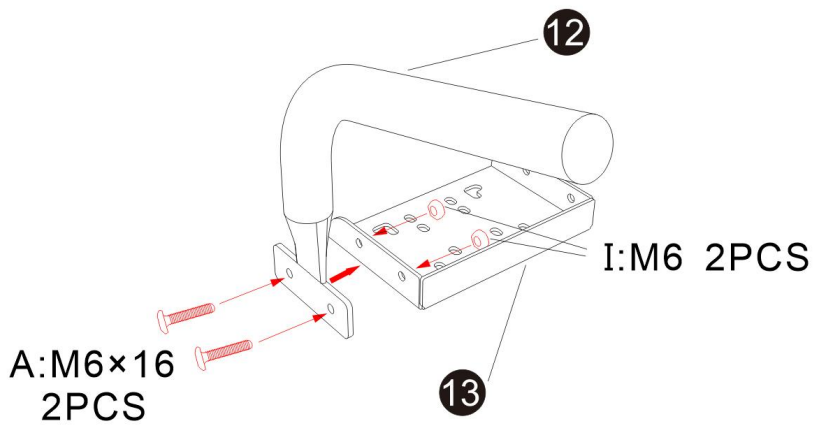

PASSO 8:

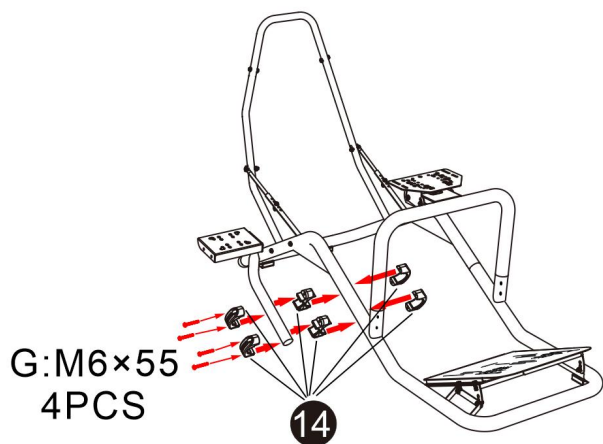

PASSO 9:

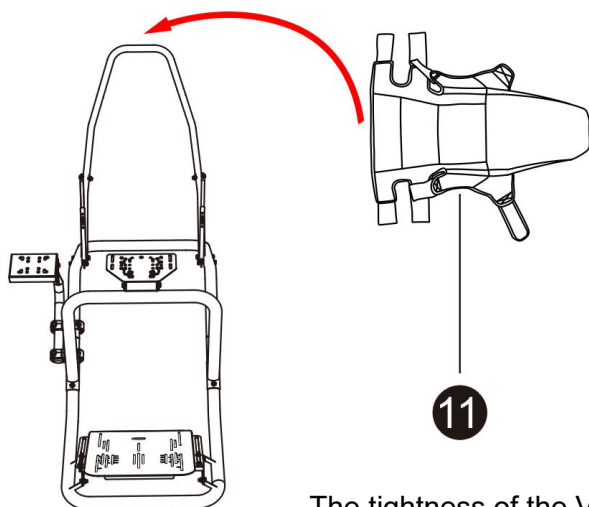

The tightness of the Velcro strap can be adjusted at will

PASSO 10:

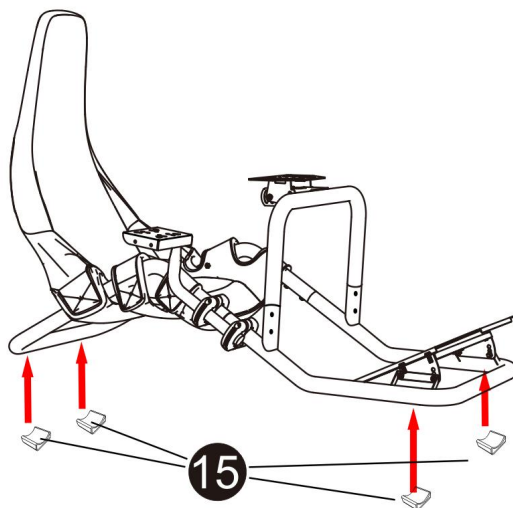

PASSO 1 1:

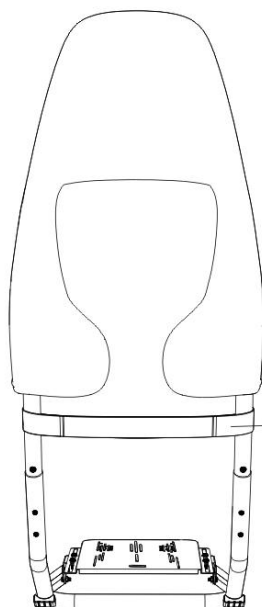

The tightness of the Velcro strap can be adjusted at will

Montaggio completo

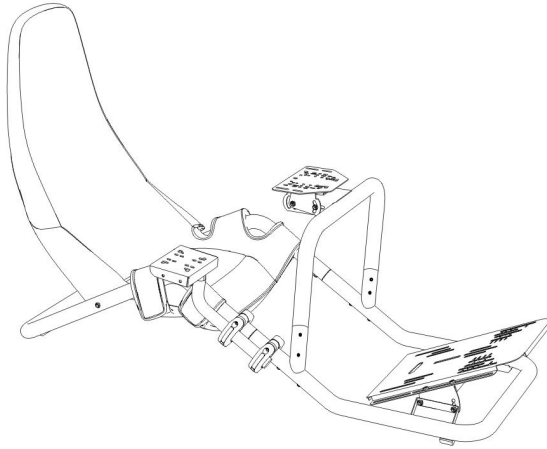

Produttore: Shanghaimuxinmuyeyouxiangongsi

Indirizzo: Shuangchenglu 803nong11hao1602A-1609shi, baoshanqu, Shanghai 200000 CN.

Importato in AUS: SIHAO PTY LTD. 1 ROKEVA STREETEASTWOOD
Nuovo Galles del Sud 2122 Australia

Importato negli USA: Sanven Technology Ltd. Suite 250, 9166 Anaheim
Luogo, Rancho Cucamonga, CA 91730

UK	REP
-----------	------------

YH CONSULTING LIMITED. C/O YH Consulting
Limited Office 147, Centurion House, London
Road, Staines-upon-Thames, Surrey, TW18 4AX

EC	REP
-----------	------------

E-CrossStu GmbH
Mainzer Landstr.69,
60329 Frankfurt am Main.



VEVOR

Affordable. Reliable. Home Improvement.

SOPORTE PARA VOLANTE

MODELO: 6019

VEVOR

Affordable. Reliable. Home Improvement.

STEERING WHEEL STAND

Modelo: 6019

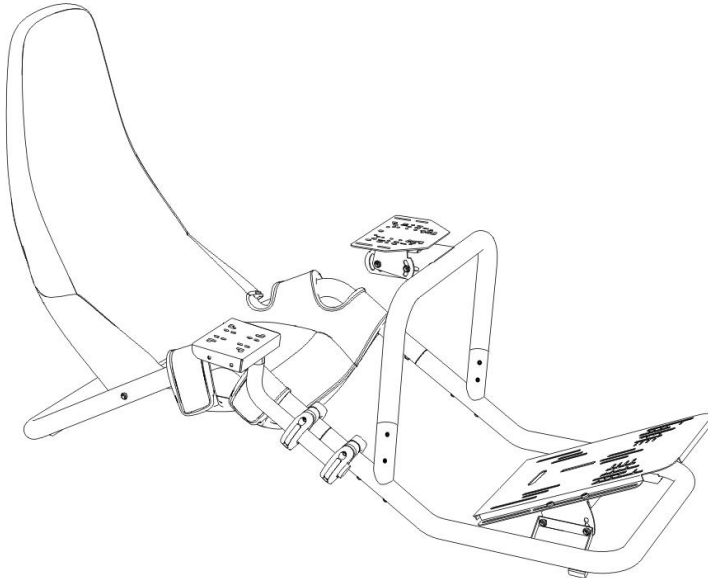

Estas son las instrucciones originales; lea atentamente todas las instrucciones del manual antes de utilizarlo. VEVOR se reserva el derecho de interpretar este manual de usuario. La apariencia del producto dependerá del producto que haya recibido. Le rogamos que no le informemos si hay actualizaciones tecnológicas o de software en nuestro producto.







Advertencia: Para reducir el riesgo de lesiones, el usuario debe leer atentamente el manual de instrucciones.



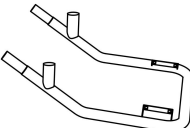

Atenciones

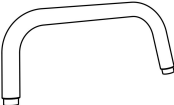
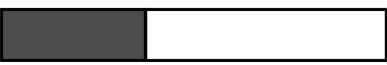

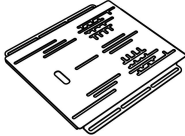
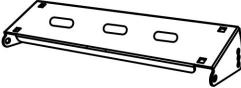
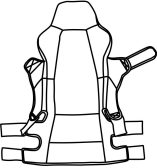

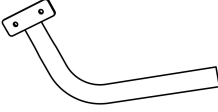
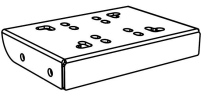
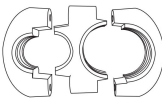
- Instale y utilice el soporte según las instrucciones .
- Por favor, instálelo con moderación, evitando vibraciones fuertes .
- No lo guarde en condiciones de humedad, altas temperaturas o en un lugar polvoriento .
- La estructura del producto es flexible, por lo que se recomienda usar guantes de trabajo durante el montaje. Tenga cuidado con las manos lastimadas al instalarlo.
- Los niños deben estar bajo la supervisión de un adulto cuando utilicen el producto.

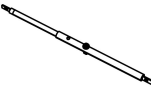
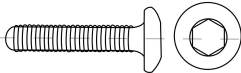
Guarde el manual.

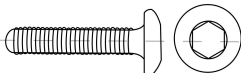
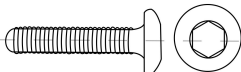
Lista de piezas			
Código	Imagen	Nombre	CANTIDAD.
1		Pedestal A	1
2		Pedestal B	1
3		Pieza en forma de U	1

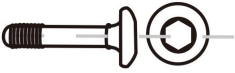
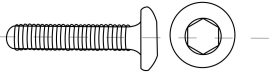
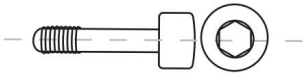
4		Bastidor principal trasero	2
5		Parte posterior de la cabeza	1
6		Correa de amarre	6
7		Cinturón de soporte lumbar	1
8		Panel del volante	1
9		Panel de pedales	1
10		Soporte de pedal	1
11		Funda de asiento	1

12		Soporte de la palanca de cambios	1
13		Panel de la palanca de cambios	1
14		sujetadores de plástico	2
15		Almohadilla de soporte de tubería	4
16		Varilla de ajuste de la espalda	2
A		Tornillo M 6×16	6 +12
B		Arandela plana M8	4 +1
do		Tornillo M 6×35	4+1
D		Tornillo M 6×55	2+1

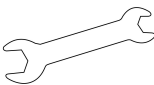
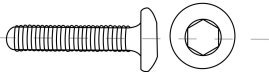
mi		Tornillo M 6×75	2+1
F		Tornillo M 8×20	12+1
GRAM O		Tornillo M 6×55	4+1
H		Tuerca de brida M8	4+1
I		Tuerca de brida M6	1 4 + 6
Yo		Llave hexagonal de 5 mm	1
K		abierto Llave inglesa 10-13	1
Yo		Tornillo M 6 × 50	4 + 1

Nota: 12 tornillos M6*16 y 6 tuercas M6 son gratuitos.

★ Para obtener la lista de kits de asientos y su instalación, consulte el manual de procedimiento de instalación del asiento adjunto.

PASO 1 :

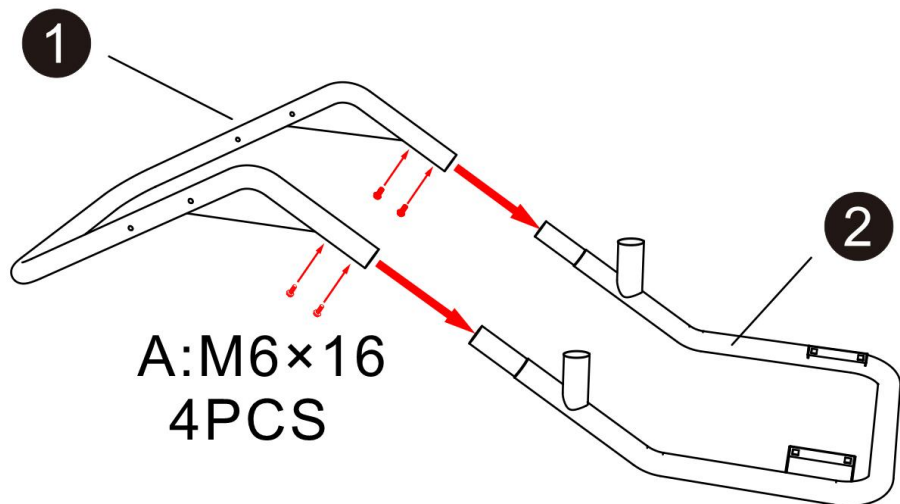

PASO 2:

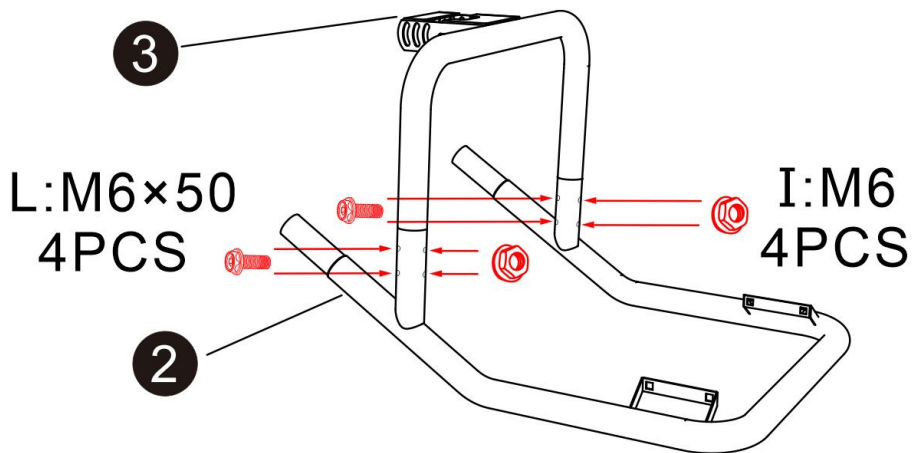

PASO 3:

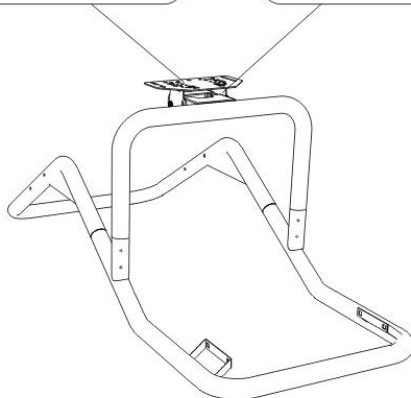
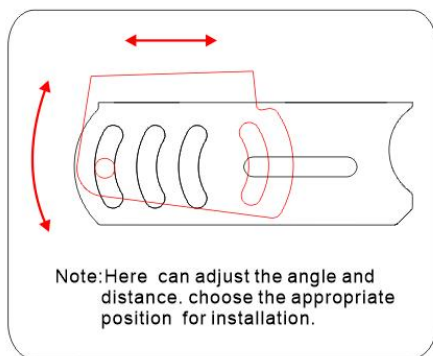
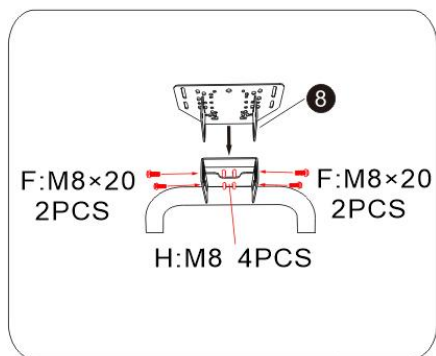

PASO 4:

Note: These 3 holes are used to adjust the angle of pedal panel. choose the appropriate hole position for installation.

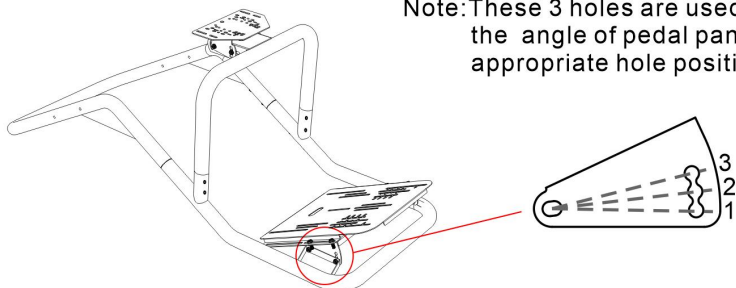

step4-1

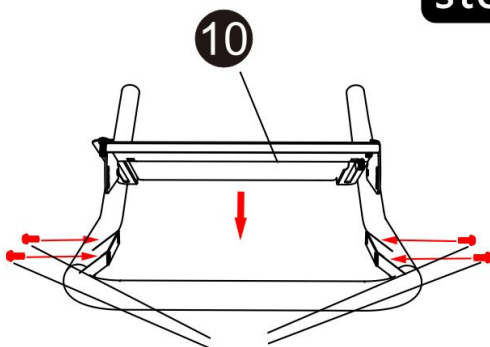

F: M8×20
4PCS

step4-2

F:M8×20 4PCS

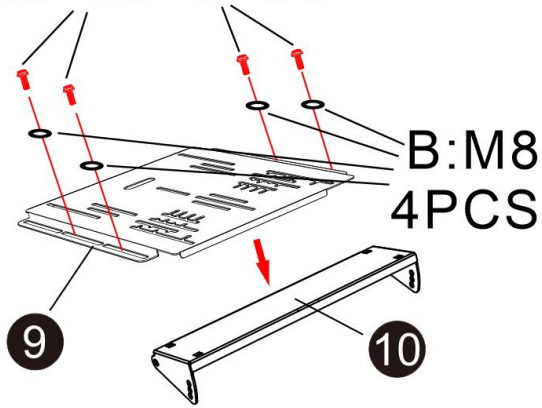

PASO 5:

step5-1

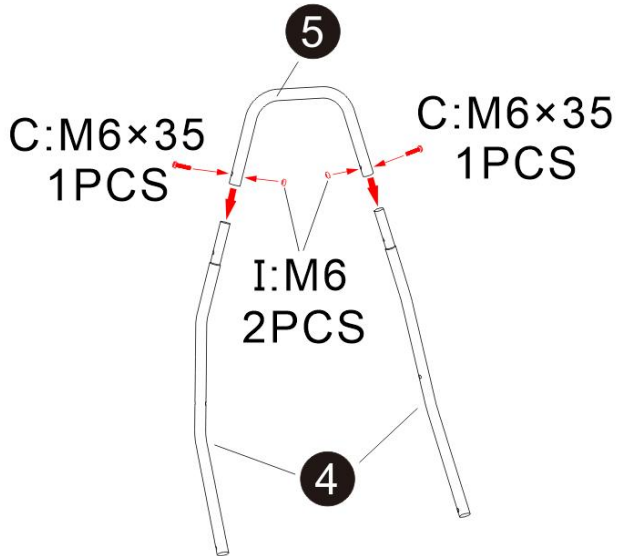

step5-2

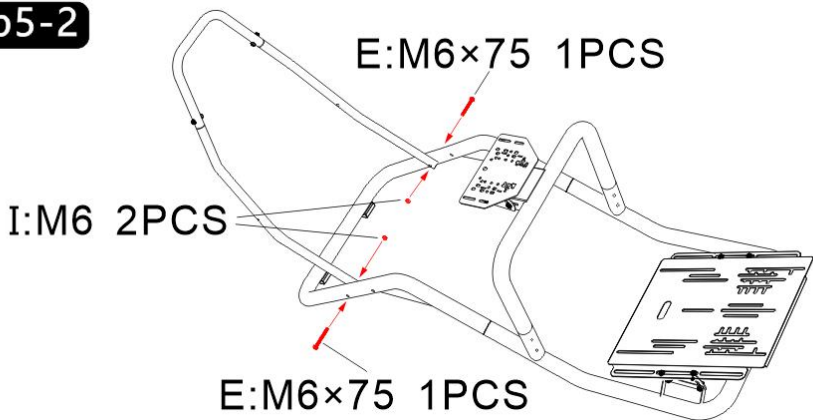

PASO 6:

Note: The pre-installed screws of accessory 16 can be disassembled and reinstalled for adjustment for the backrest angle, choose the appropriate hole position for installation.

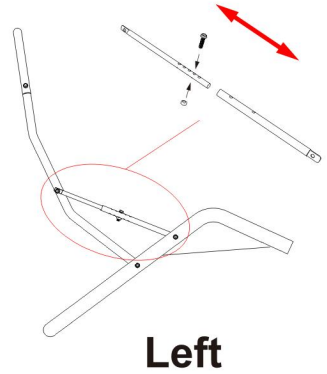
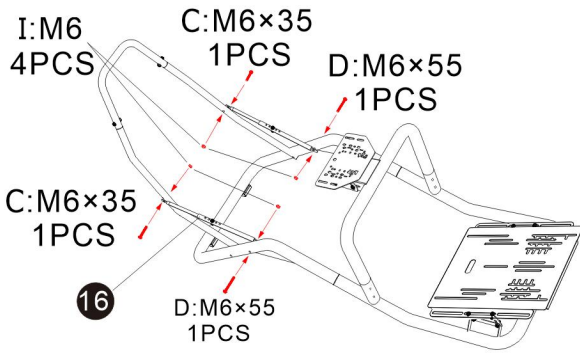

PASO 7:

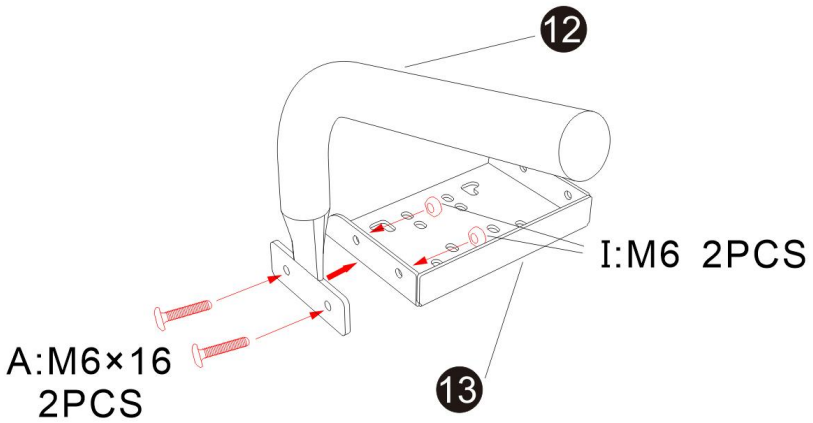

PASO 8:

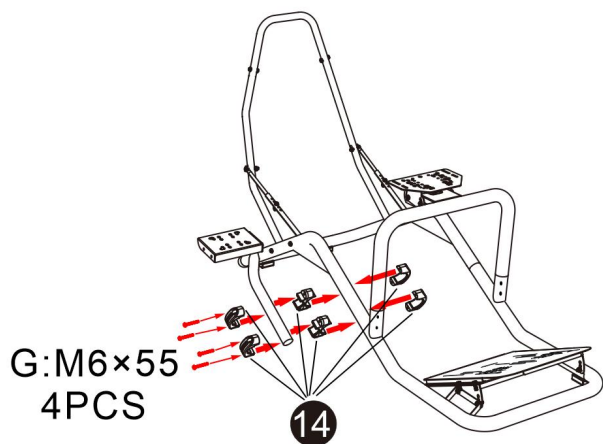

PASO 9:

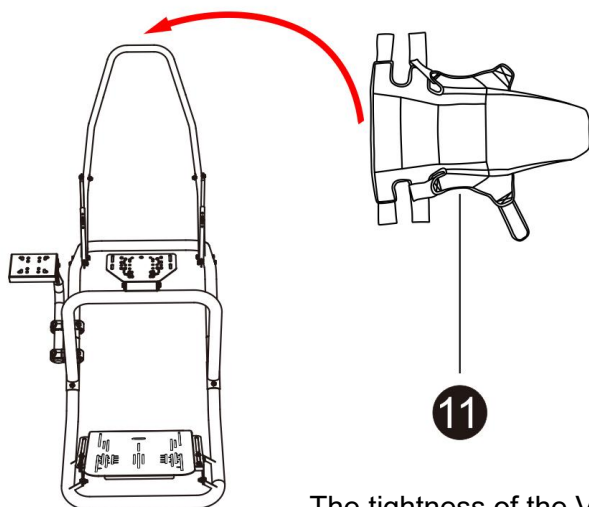

The tightness of the Velcro strap can be adjusted at will

PASO 10:

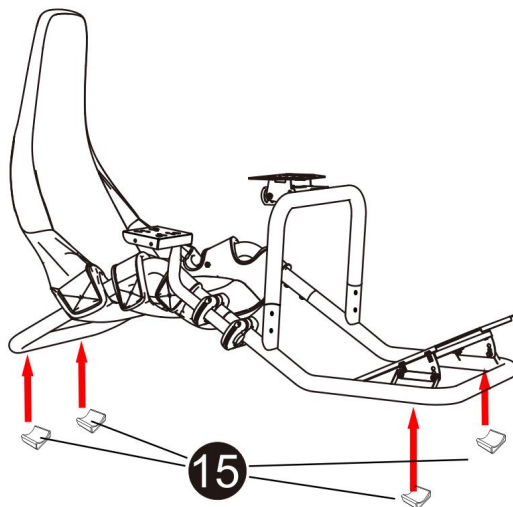

PASO 1 1:

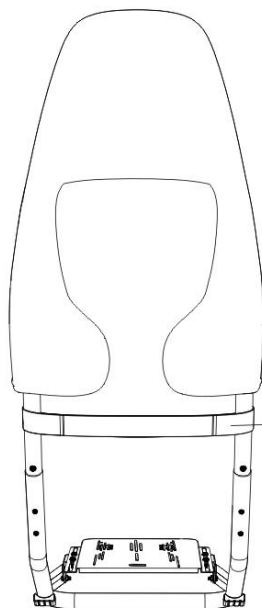

The tightness of the Velcro strap can be adjusted at will

Montaje completo

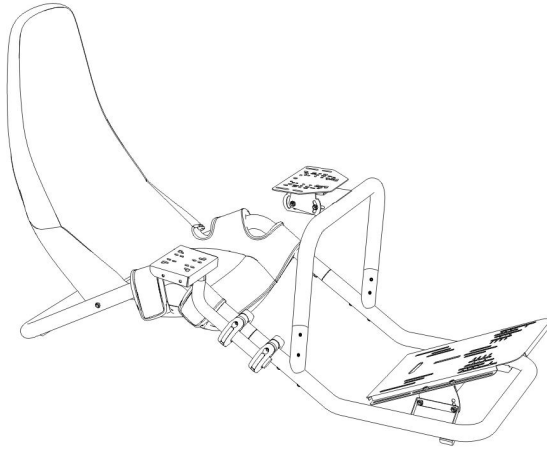

Fabricante: Shanghaimuxinmuyeyouxiangongsi

Dirección: Shuangchenglu 803nong11hao1602A-1609shi, baoshanqu, Shanghái 200000 CN.

Importado a AUS: SIHAO PTY LTD. 1 ROKEVA STREET, EASTWOOD NSW 2122 Australia

Importado a EE. UU.: Sanven Technology Ltd. Suite 250, 9166 Anaheim Lugar, Rancho Cucamonga, CA 91730

UK	REP
-----------	------------

YH CONSULTING LIMITED. C/O YH Consulting Limited Office 147, Centurion House, London Road, Staines-upon-Thames, Surrey, TW18 4AX

EC	REP
-----------	------------

E-CrossStu GmbH
Mainzer Landstr.69,
60329 Frankfurt am Main.



VEVOR

Affordable. Reliable. Home Improvement.

PODSTAWKA POD KIEROWNICĘ

MODEL: 6019

VEVOR

Affordable. Reliable. Home Improvement.

STEERING WHEEL STAND

Model: 6019

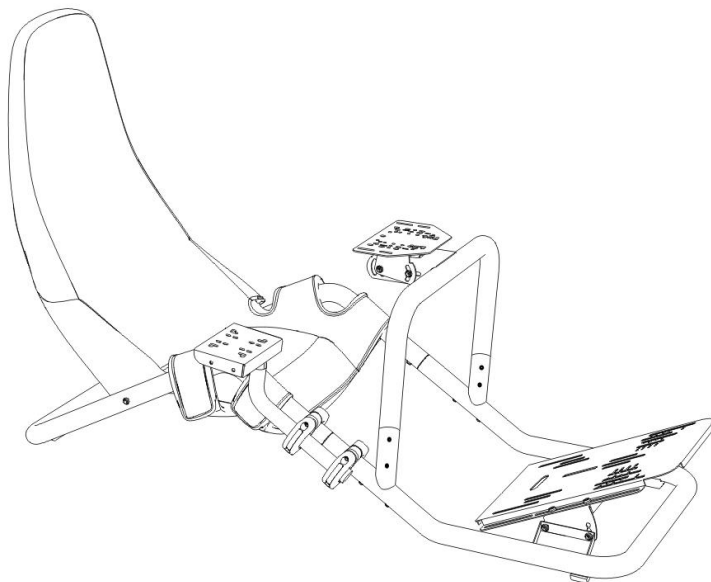

To jest oryginalna instrukcja obsługi. Przed użyciem prosimy o dokładne zapoznanie się z treścią instrukcji. Firma VEVOR zastrzega sobie prawo do jednoznacznej interpretacji niniejszej instrukcji obsługi. Wygląd produktu zależy od stanu, w jakim go otrzymali Państwo. Prosimy o wyrozumiałość, ale nie będziemy Państwa ponownie informować o aktualizacjach technologicznych lub oprogramowania naszego produktu.









Ostrzeżenie: Aby zminimalizować ryzyko obrażeń, użytkownik powinien uważnie przeczytać instrukcję obsługi.

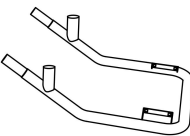

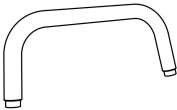

Uprzejmości



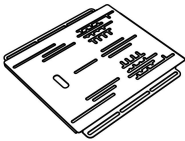
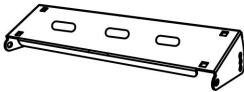
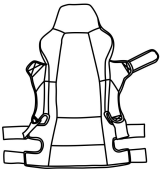

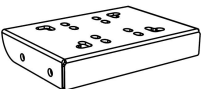
- Proszę zainstalować i używać stojak zgodnie z instrukcją .
- Dokonuj umiarkowanego montażu, unikaj silnych wibracji .
- Nie przechowywać w wilgotnych warunkach, wysokich temperaturach ani w miejscach zakurzonych .
- Produkt jest elastyczny, dlatego podczas montażu należy nosić rękawice robocze. Należy zachować ostrożność podczas instalacji, aby nie zranić dłoni.
- Dzieci powinny używać produktu pod nadzorem osoby dorosłej.

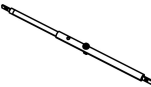
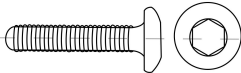
Zapisz instrukcję.

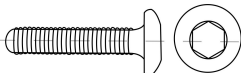
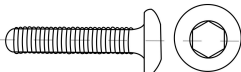
Lista części			
Kod	Zdjęcie	Nazwa	ILOŚĆ
1		Postument A	1
2		Postument B	1
3		Część w kształcie litery U	1
4		Tyłna rama główna	2

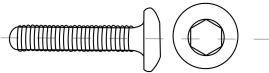
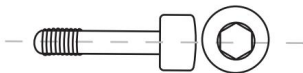
5		Tył głowy	1
6		Pas mocujący	6
7		Pas podtrzymujący odcinek lędźwiowy	1
8		Panel kierownicy	1
9		Panel pedałów	1
10		Uchwyt pedału	1
11		Pokrowiec na siedzenie	1

12		Uchwyt dźwigni zmiany biegów	1
13		Panel dźwigni zmiany biegów	1
14		Elementy złączne z tworzywa sztucznego	2
15		Podkładka pod rurę	4
16		Pręt regulacji pleców	2
A		Śruba M 6×16	6 +12
B		Podkładka płaska M8	4 +1
C		Śruba M 6×35	4+1
D		Śruba M 6×55	2+1

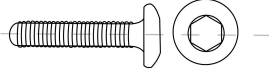
mi		Śruba M 6×75	2+1
F		Śruba M 8×20	12+1
G		Śruba M 6×55	4+1
H		Nakrętka kołnierzowa M8	4+1
I		Nakrętka kołnierzowa M6	1 4 +6
J		Klucz imbusowy 5mm	1
K		otwarty koniec Klucz 10-13	1
L		Śruba M 6 × 50	4 +1

Uwaga: 12 śrub M6*16 i 6 nakrętek M6 jest dostarczanych w komplecie.

★ Listę zestawów fotelików i sposobów ich montażu znajdziesz w załączonej instrukcji montażu fotelika.

KROK 1 :

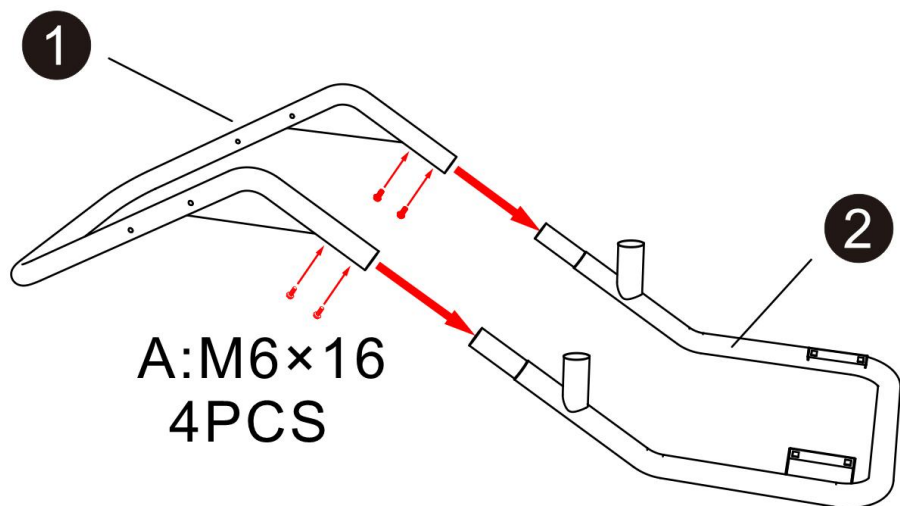

KROK 2:

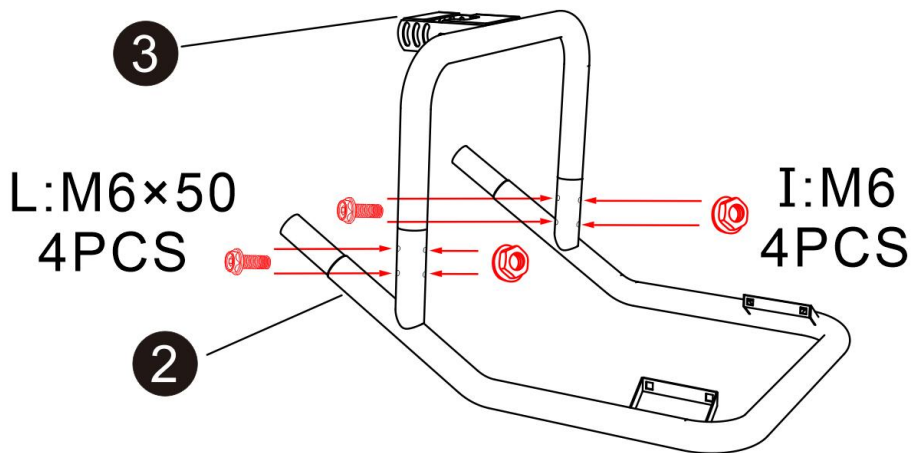

KROK 3:

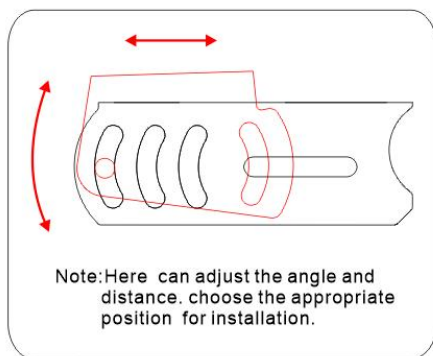
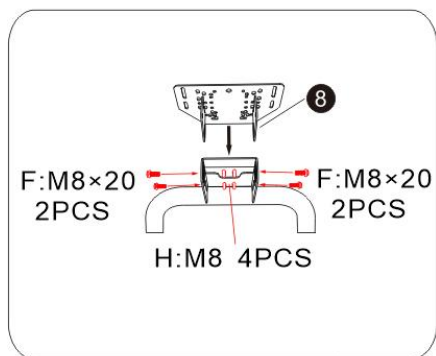

KROK 4:

Note: These 3 holes are used to adjust the angle of pedal panel. choose the appropriate hole position for installation.

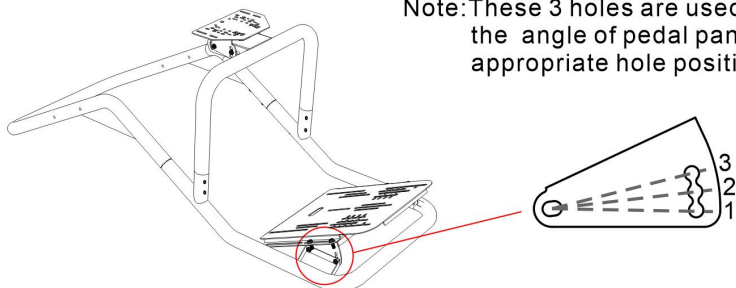

step4-1

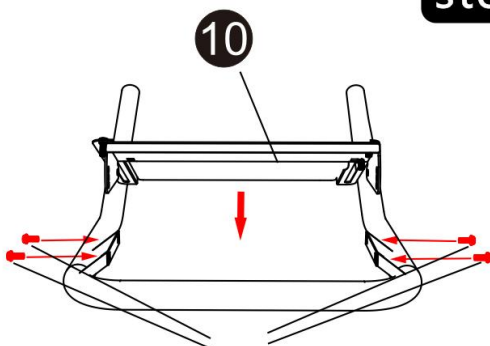

F: M8×20
4PCS

step4-2

F:M8×20 4PCS

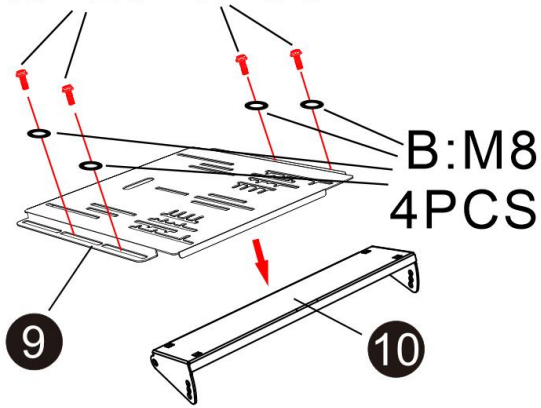

KROK 5:

step5-1

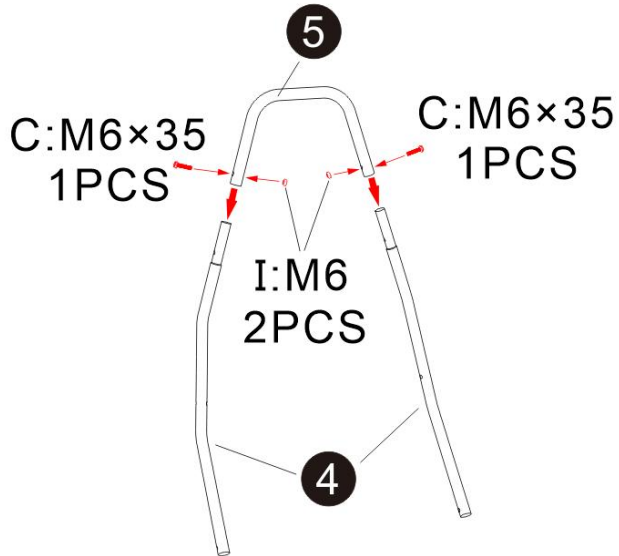

step5-2

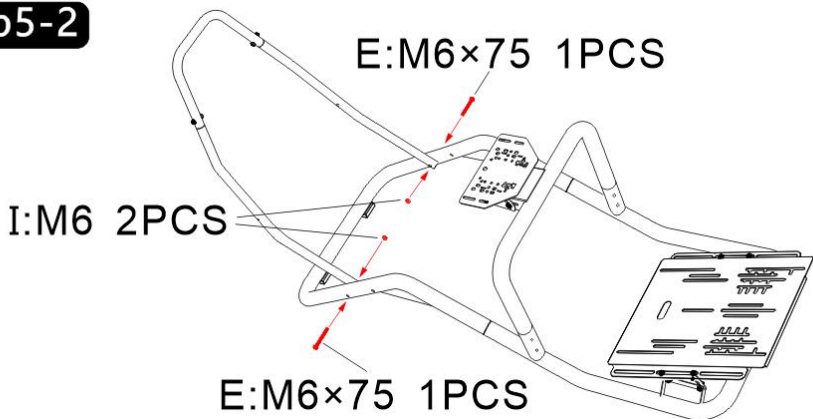

KROK 6:

Note: The pre-installed screws of accessory 16 can be disassembled and reinstalled for adjustment for the backrest angle, choose the appropriate hole position for installation.

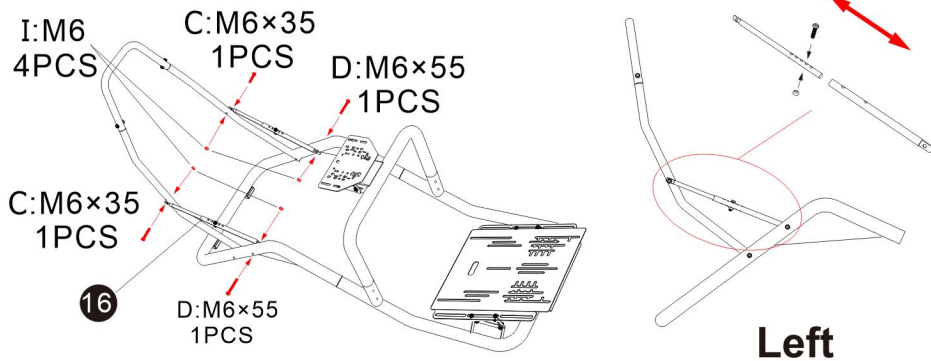

KROK 7:

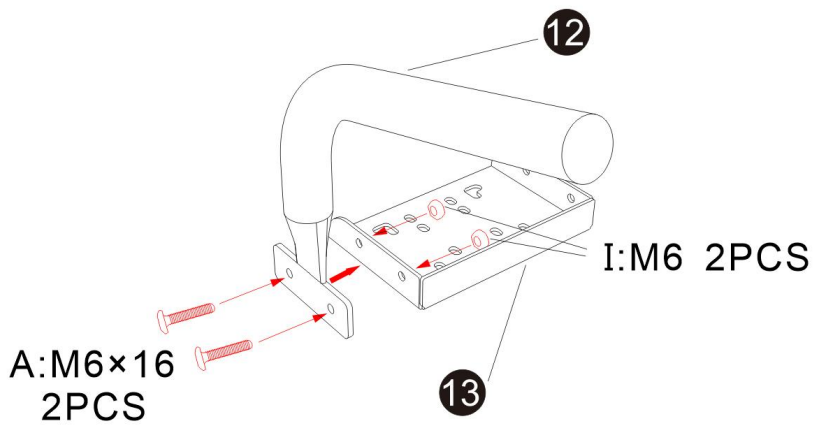

KROK 8:

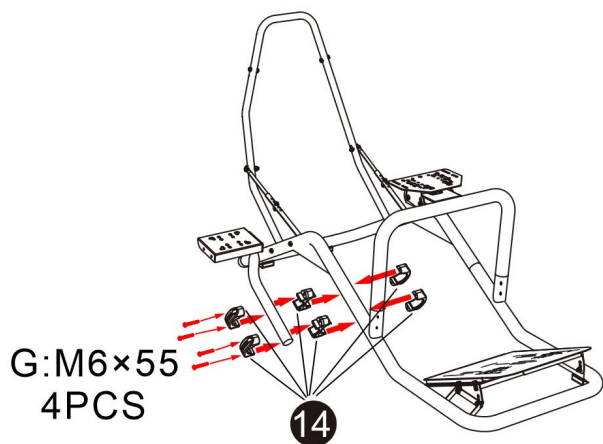

KROK 9:

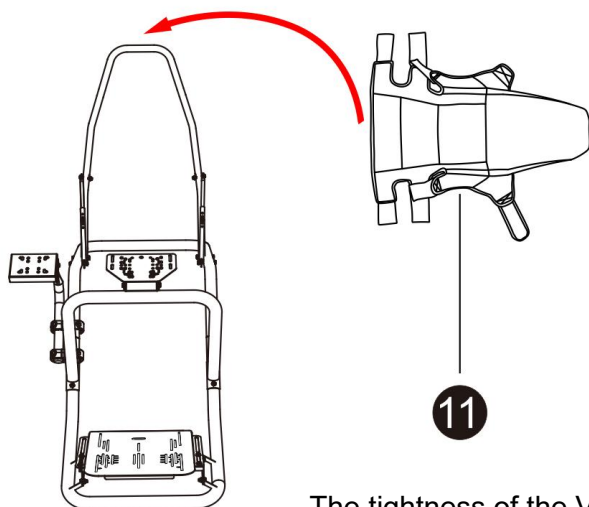

The tightness of the Velcro strap can be adjusted at will

KROK 10:

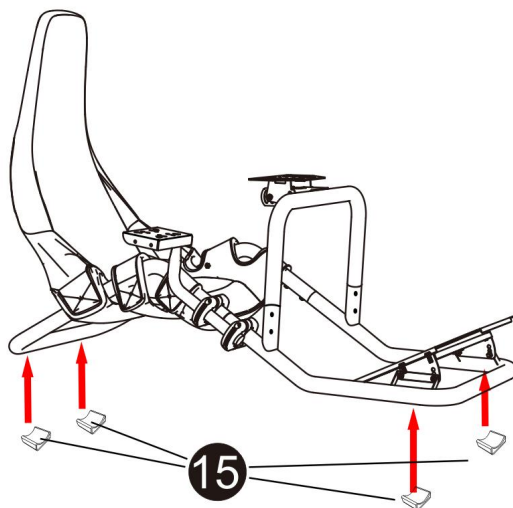

KROK 1 1:

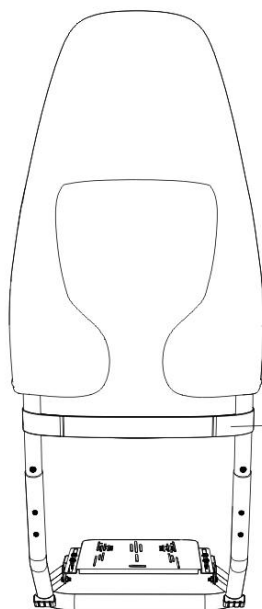

The tightness of the Velcro strap can be adjusted at will

Kompletny montaż

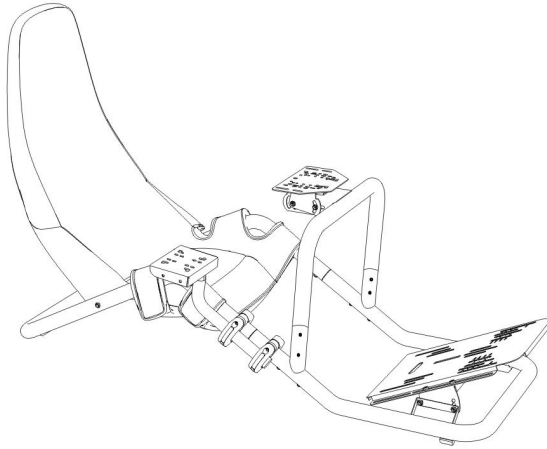

Producent: Shanghai muxin muyeyouxiangongsi

Adres: Shuangchenglu 803nong11hao1602A-1609shi, baoshanqu, szanghaj 200000 CN.

Importowane do AUS: SIHAO PTY LTD. 1 ROKEVA
STREET EASTWOOD
NSW 2122 Australia

Importowane do USA: Sanven Technology Ltd. Suite 250, 9166 Anaheim
Miejsce, Rancho Cucamonga, CA 91730

UK	REP
-----------	------------

YH CONSULTING LIMITED. C/O YH Consulting
Limited Office 147, Centurion House, London
Road, Staines-upon-Thames, Surrey, TW18 4AX

EC	REP
-----------	------------

E-CrossStu GmbH
Mainzer Landstr.69,
60329 Frankfurt am Main.



VEVOR

Affordable. Reliable. Home Improvement.

STUURWIELSTANDAARD

MODEL: 6019

Model: 6019

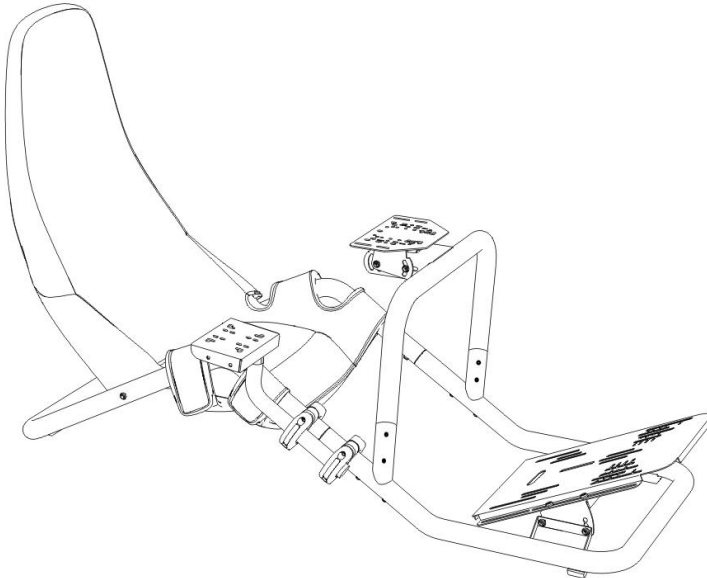

Dit is de originele handleiding. Lees alle instructies zorgvuldig door voordat u het product gebruikt. VEVOR behoudt zich het recht voor om de gebruiksaanwijzing duidelijk te interpreteren. Het uiterlijk van het product is afhankelijk van het product dat u hebt ontvangen. Neemt u het ons niet kwalijk dat we u niet meer op de hoogte stellen van eventuele technologische of software-updates voor ons product.







Waarschuwing: om het risico op letsel te verminderen, moet de gebruiker de gebruiksaanwijzing zorgvuldig lezen.



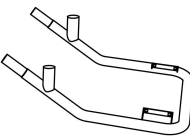

Aandacht

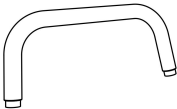

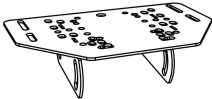
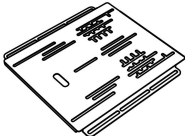
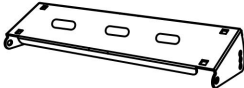
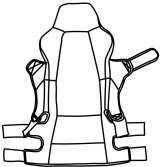
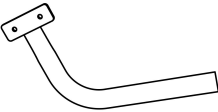

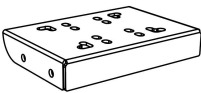
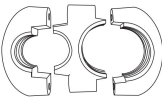
- Installeer en gebruik de standaard volgens de instructies .
- Installeer het voorzichtig en vermijd sterke trillingen .
- Niet bewaren op een vochtige plaats, bij hoge temperaturen of op een stoffige plaats .
- De productstructuur is flexibel. Draag werkhandschoenen tijdens de montage. Let op een pijnlijke hand tijdens de installatie.
- Kinderen dienen dit product onder toezicht van een volwassene te gebruiken.

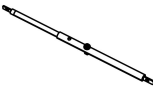
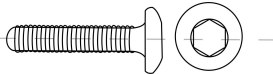
Bewaar de handleiding.

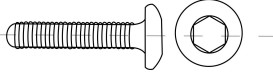
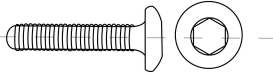
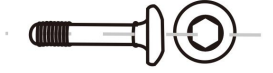
Onderdelenlijst			
Code	Afbeelding	Naam	AANTAL
1		Voetstuk A	1
2		Voetstuk B	1
3		U-vormig onderdeel	1
4		Achterhoofdframe	2

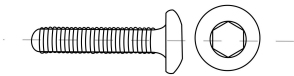
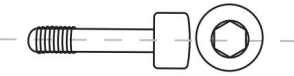
5		Achterkant van het hoofd	1
6		Vastzetriem	6
7		Lendensteungordel	1
8		Stuurwielpaneel	1
9		Pedaalpaneel	1
10		Pedaalhouder	1
11		Stoelhoes	1
12		Versnellingshendelhouder	1

13		Versnellingspook paneel	1
14		Kunststof bevestigingsmid- delen	2
15		Buisondersteunin- gspad	4
16		Rugverstelstang	2
A		Schroef M 6×16	6 +12
B		Platte ring M8	4 +1
C		Schroef M 6×35	4+1
D		Schroef M 6×55	2+1
E		Schroef M 6×75	2+1

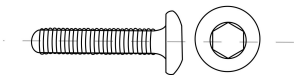
F		Schroef M 8x20	12+1
G		Schroef M 6x55	4+1
H		Flensmoer M8	4+1
I		Flensmoer M6	1 4 +6
J		Inbussleutel 5mm	1
K		open einde Sleutel 10-13	1
L		Schroef M 6 x 50	4 +1

Let op: 12 schroeven M6*16 en 6 moeren M6 zijn inbegrepen.

★ Raadpleeg de bijgevoegde handleiding met de stoelinstallatieprocedure voor een lijst met stoelsets en de installatie ervan.

STAP 1 :

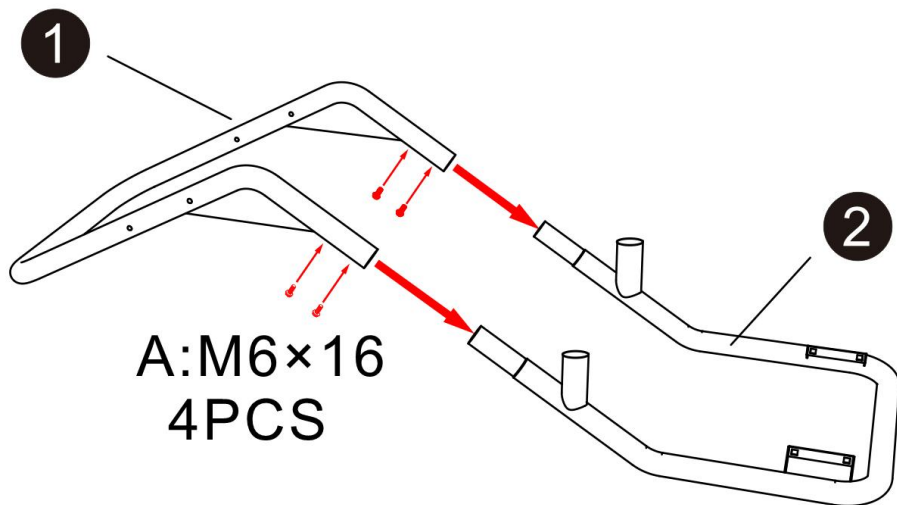

STAP 2:

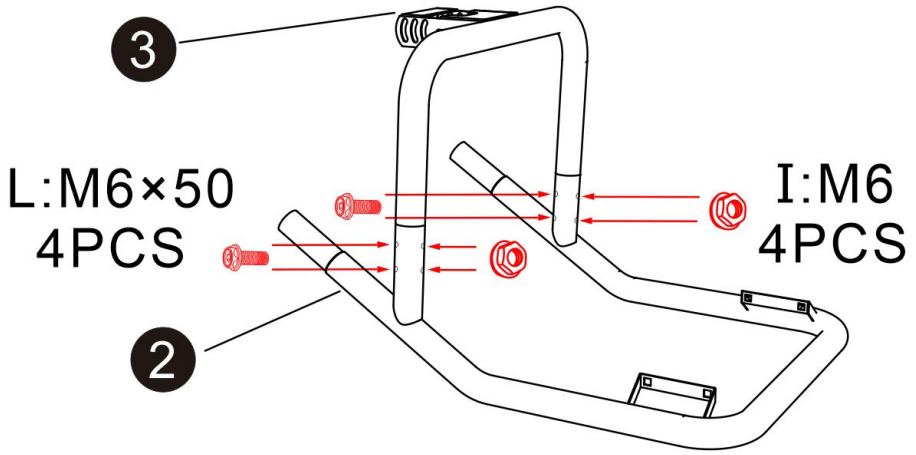

STAP 3:

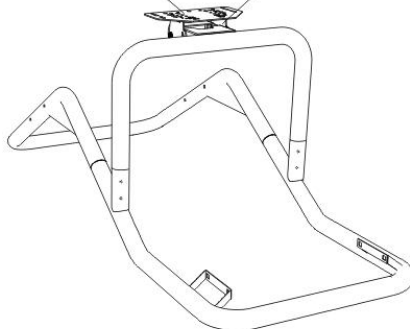
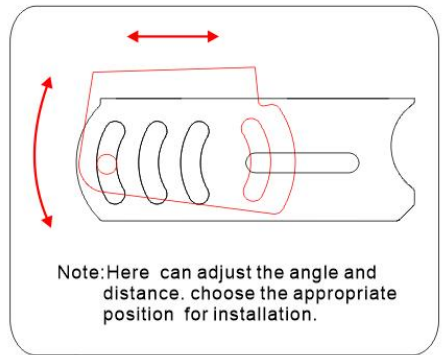
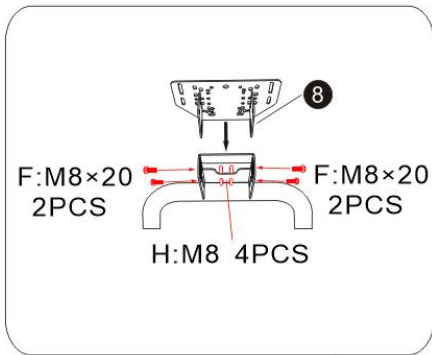

STAP 4:

Note: These 3 holes are used to adjust the angle of pedal panel. choose the appropriate hole position for installation.

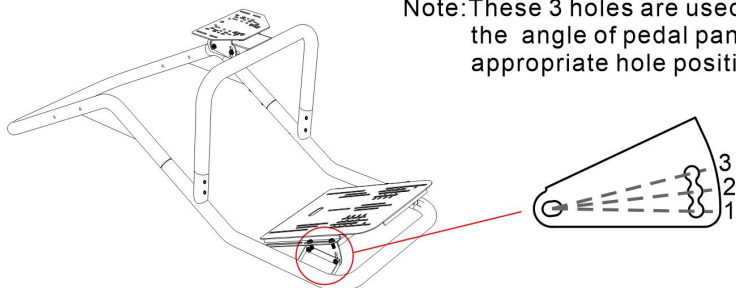

step4-1

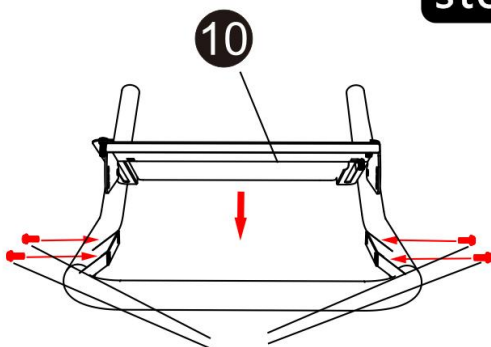

F: M8×20
4PCS

step4-2

F:M8×20 4PCS

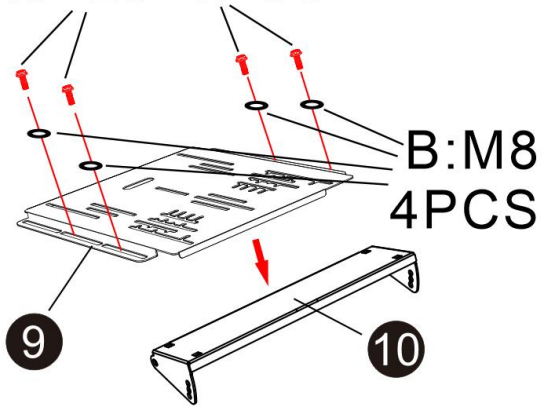

STAP 5:

step5-1

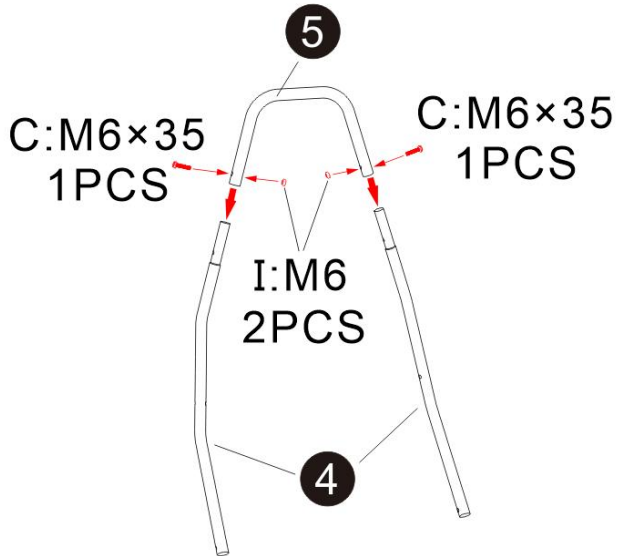

step5-2

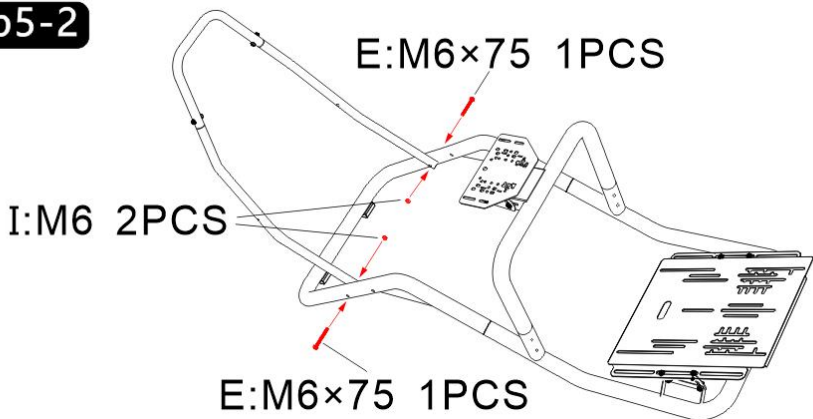

STAP 6:

Note: The pre-installed screws of accessory 16 can be disassembled and reinstalled for adjustment for the backrest angle, choose the appropriate hole position for installation.

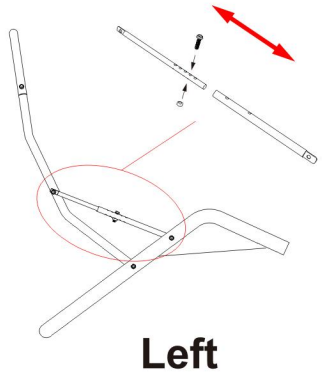
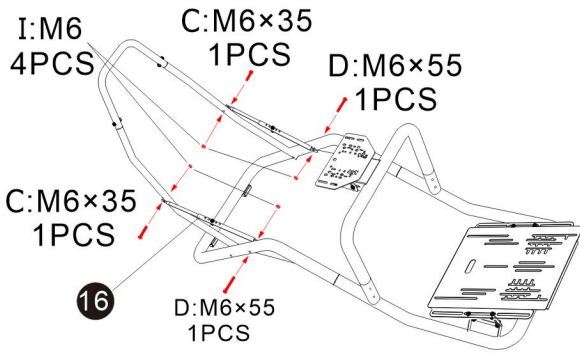

STAP 7:

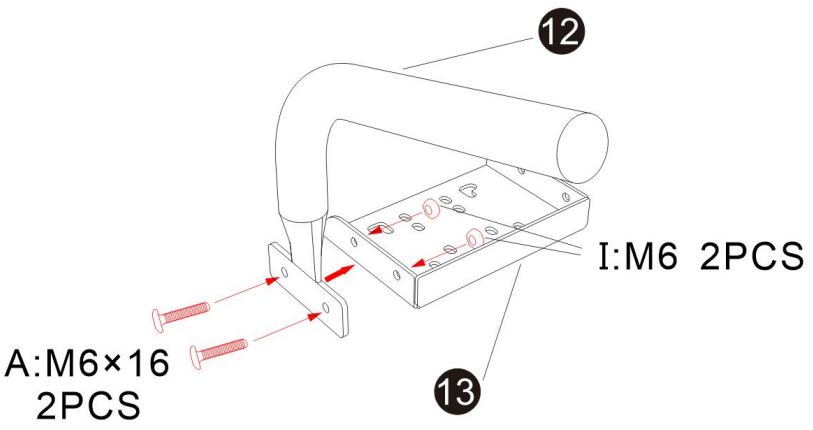

STAP 8:

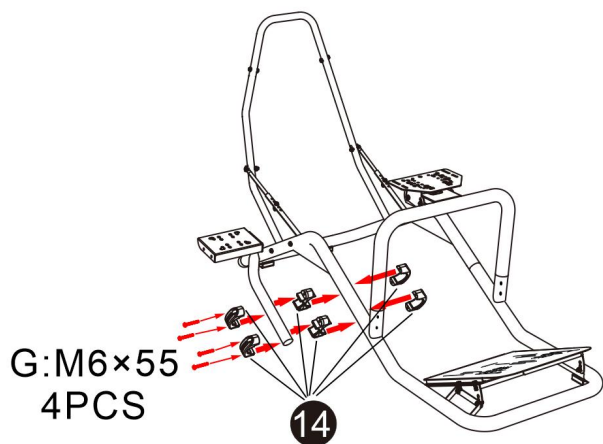

STAP 9:

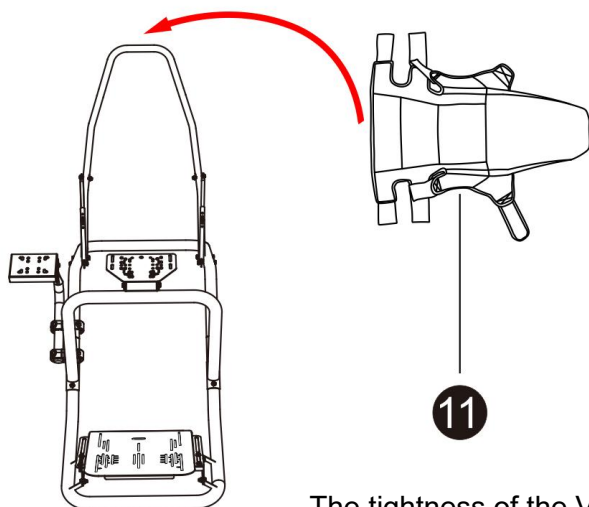

The tightness of the Velcro strap can be adjusted at will

STAP 10:

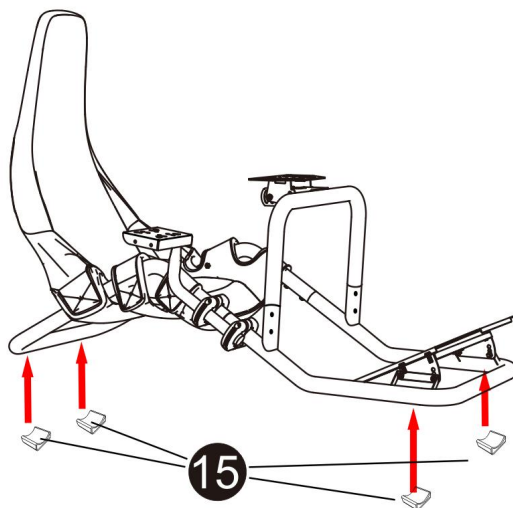

STAP 1 1:

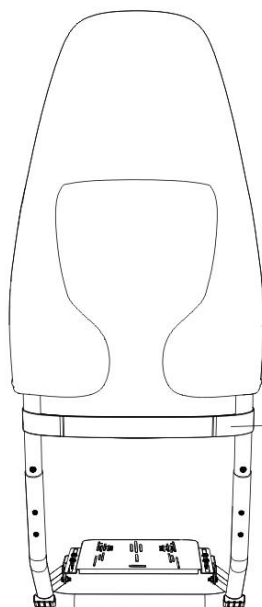

The tightness of the Velcro strap can be adjusted at will

Volledige montage

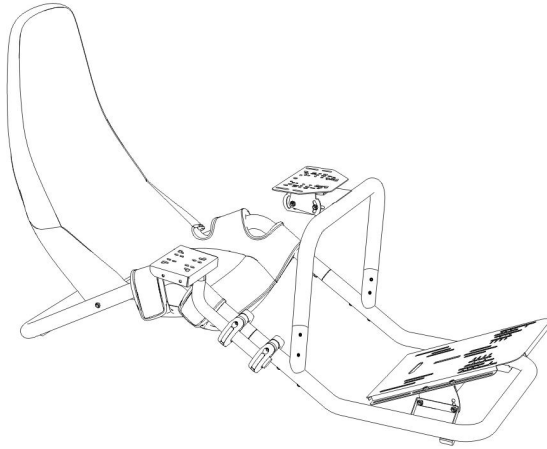

Fabrikant: Shanghaimuxinmuyeyouxiangongsi

Adres: Shuangchenglu 803nong11hao1602A-1609shi, baoshanqu, shanghai 200000 CN.

Geïmporteerd naar AUS: SIHAO PTY LTD. 1 ROKEVA
STREETEASTWOOD
NSW 2122 Australië

Geïmporteerd naar de VS: Sanven Technology Ltd. Suite 250, 9166
Anaheim
Plaats, Rancho Cucamonga, CA 91730

UK	REP
-----------	------------

YH CONSULTING LIMITED. C/O YH Consulting
Limited Office 147, Centurion House, London
Road, Staines-upon-Thames, Surrey, TW18 4AX

EC	REP
-----------	------------

E-CrossStu GmbH
Mainzer Landstr.69,
60329 Frankfurt am Main.



VEVOR

Affordable. Reliable. Home Improvement.

RATTSTYCK

MODELL: 6019

VEVOR

Affordable. Reliable. Home Improvement.

STEERING WHEEL STAND

Modell: 6019

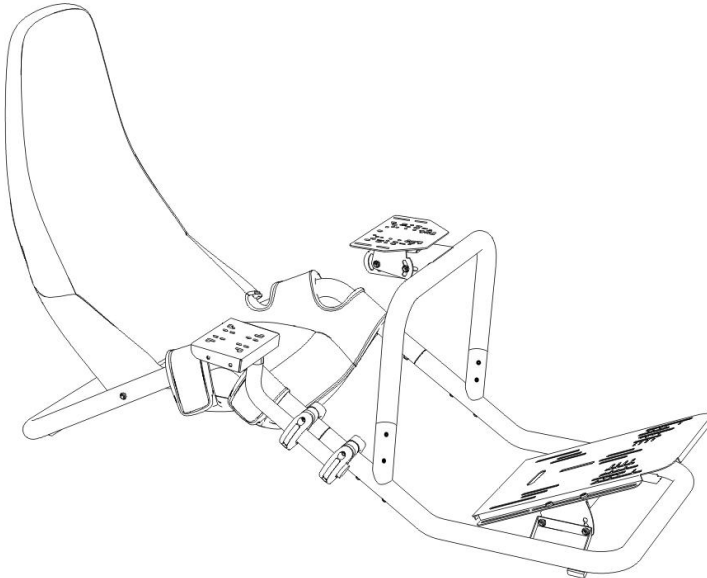

Detta är originalinstruktionerna, vänligen läs alla instruktioner noggrant innan du använder produkten. VEVOR förbehåller sig en tydlig tolkning av vår användarmanual. Produktens utseende ska vara beroende av den produkt du mottagit. Vi ber om ursäkt för att vi inte kommer att informera dig igen om det finns några teknik- eller programuppdateringar för vår produkt.









Varning – För att minska risken för skador måste användaren läsa instruktionsmanualen noggrant.

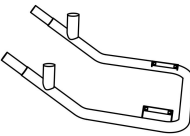

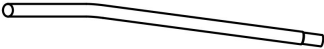

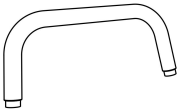
Uppmärksamhet



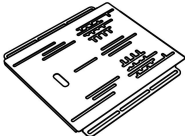
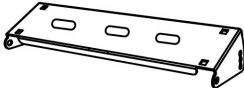
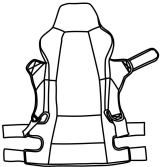
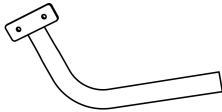

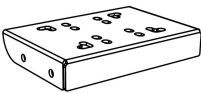
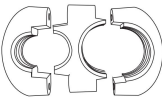
- Installera och använd stativet enligt anvisningarna .
- Installera med måtta och undvik starka vibrationer .
- Förvara inte i fuktiga förhållanden, höga temperaturer eller dammiga platser .
- Produktstrukturen är flexibel, använd arbetshandskar vid montering. Var försiktig med värkande händer vid installation.
- Barn bör vara under vuxenövervakning när de använder produkten.

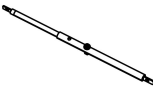
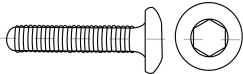
Spara manualen.

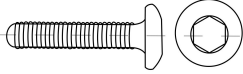
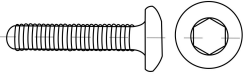
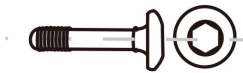
Dellista			
Koda	Bild	Namn	ANTAL
1		Piedestal A	1
2		Piedestal B	1
3		U-formad del	1
4		Bakre huvudram	2

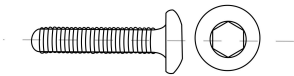
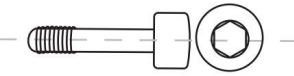
5		Baksidan av huvudet	1
6		Spännrem	6
7		Ländryggsstödsbälte	1
8		Rattpanel	1
9		Pedalpanel	1
10		Pedalhållare	1
11		Sätessöverdrag	1
12		Växelspakshållare	1

13		Växelspåkspanel	1
14		Plastfästen	2
15		Rörstödplatta	4
16		Ryggjusteringsstång	2
En		Skruv M6 ×16	6 +12
B		Plattbricka M8	4 +1
C		Skruv M6 ×35	4+1
D		Skruv M6 ×55	2+1
E		Skruv M6 ×75	2+1

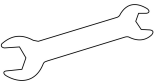
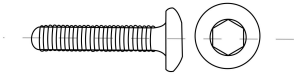
F		Skruv M8 x20	12+1
G		Skruv M6 x55	4+1
H		Flänsmutter M8	4+1
Jag		Flänsmutter M6	1 4 + 6
J		Sexkantsnyckel 5 mm	1
K		öppen ände Skiftnyckel 10-13	1
L		Skruv M6 x 50	4 +1

Obs: 12 st. skruvar M6*16 och 6 st. muttrar M6 medföljer utan extra kostnad.

★ För en lista över sitssatser och installation, se den bifogade manualen för sitsinstallationen.

STEG 1 :

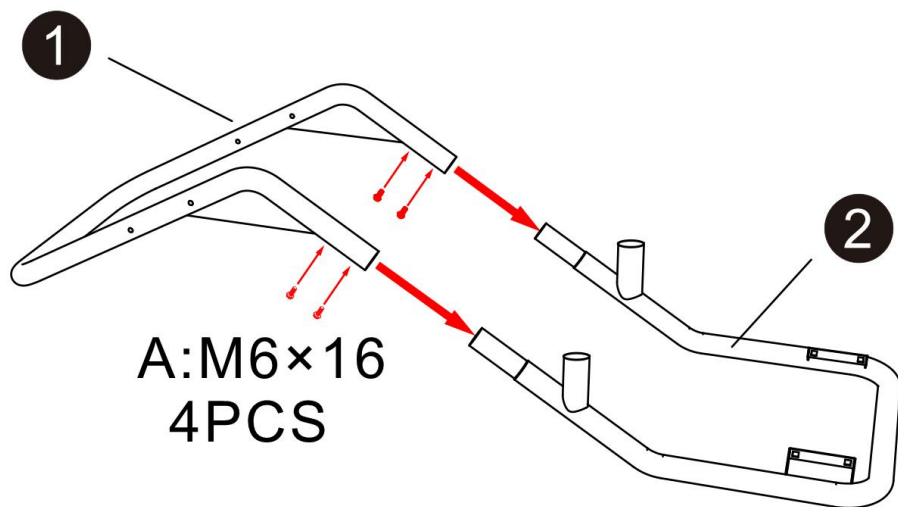

STEG 2:

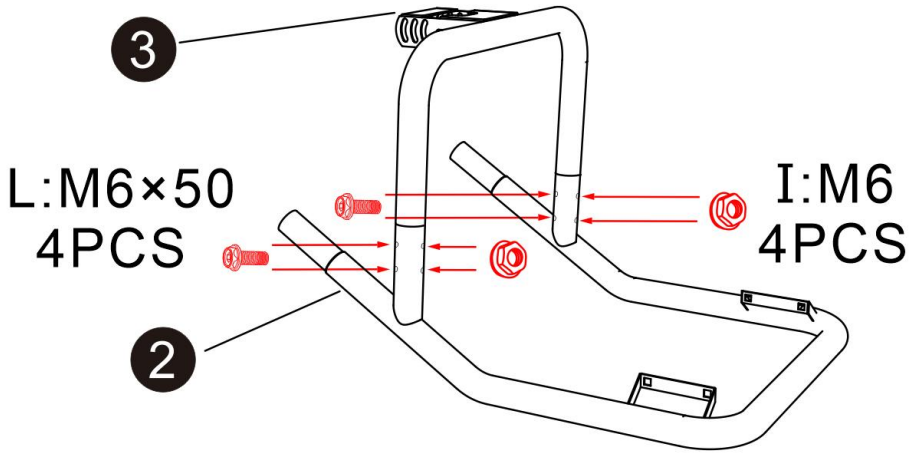

STEP 3:

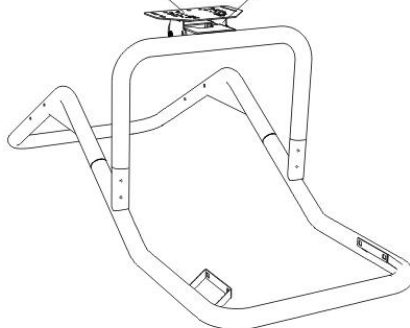
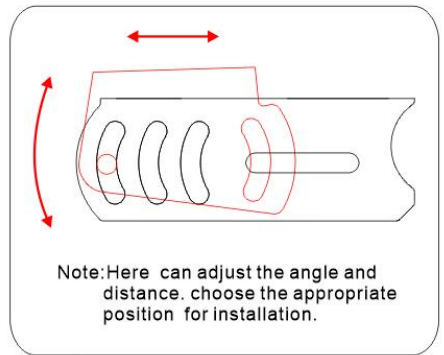
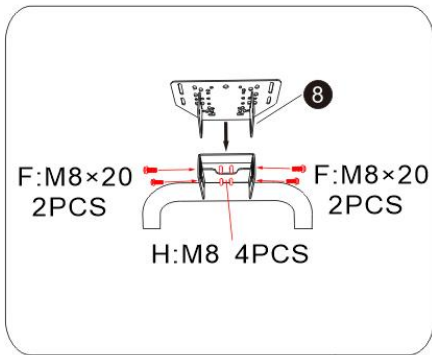

STEG 4:

Note: These 3 holes are used to adjust the angle of pedal panel. choose the appropriate hole position for installation.

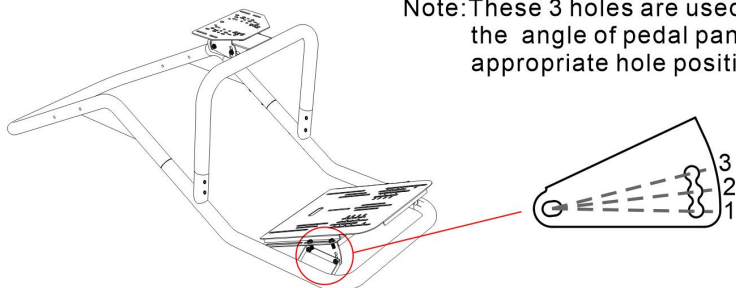

step4-1

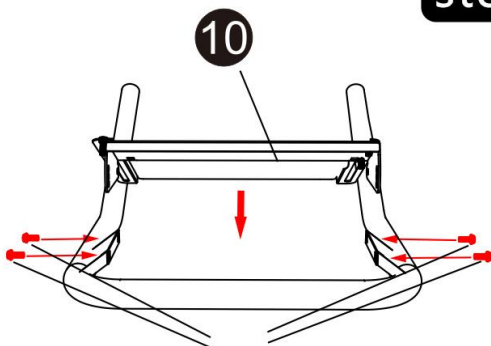

F: M8×20
4PCS

step4-2

F:M8×20 4PCS

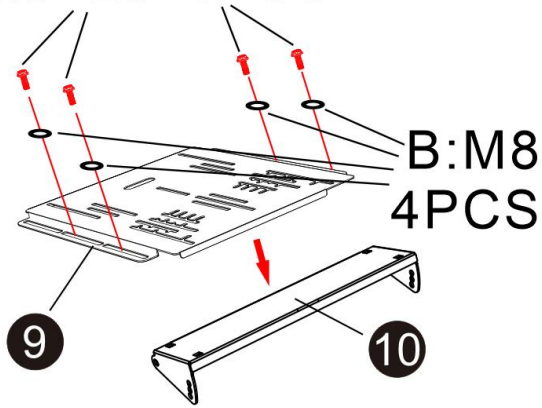

STEP 5:

step5-1

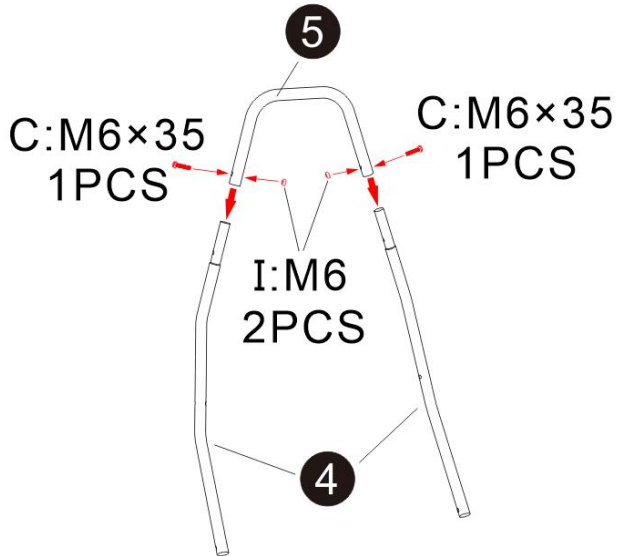

step5-2

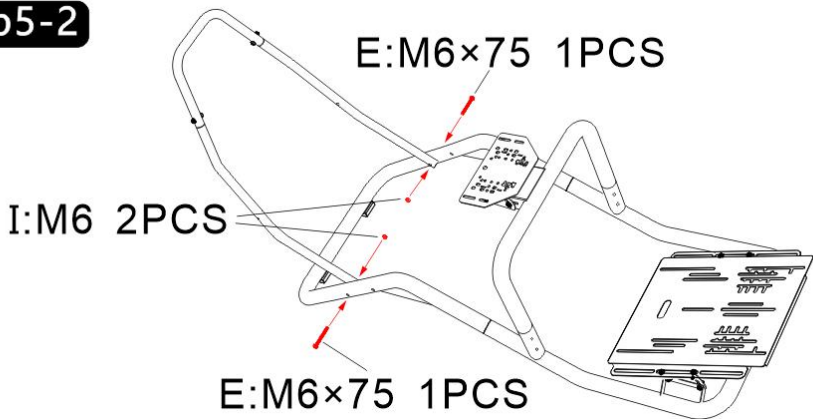

STEP 6:

Note: The pre-installed screws of accessory 16 can be disassembled and reinstalled for adjustment for the backrest angle, choose the appropriate hole position for installation.

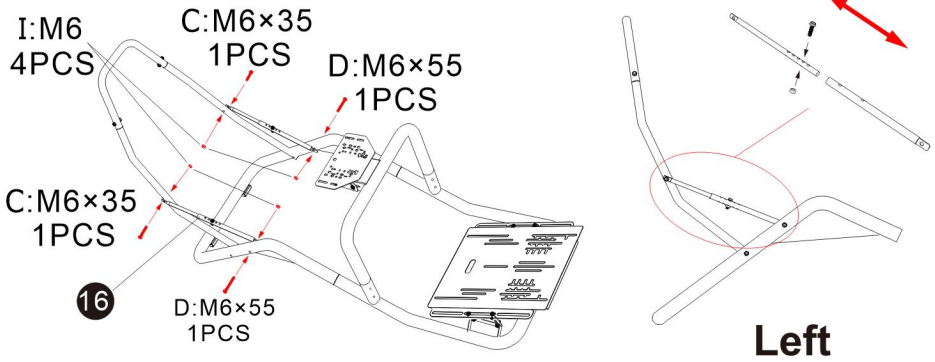

STEP 7:

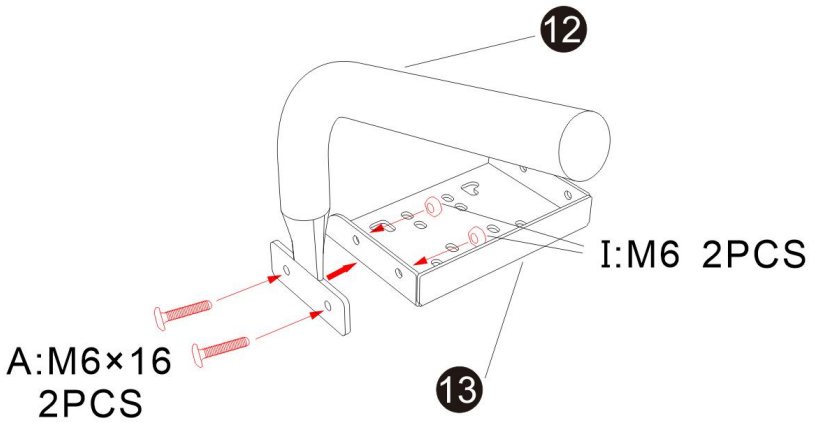

STEP 8:

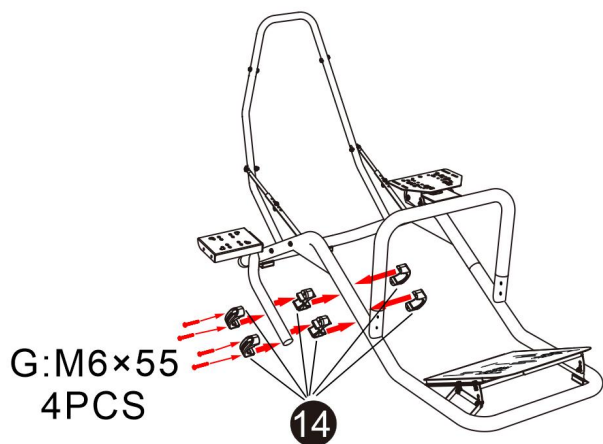

STEP 9:

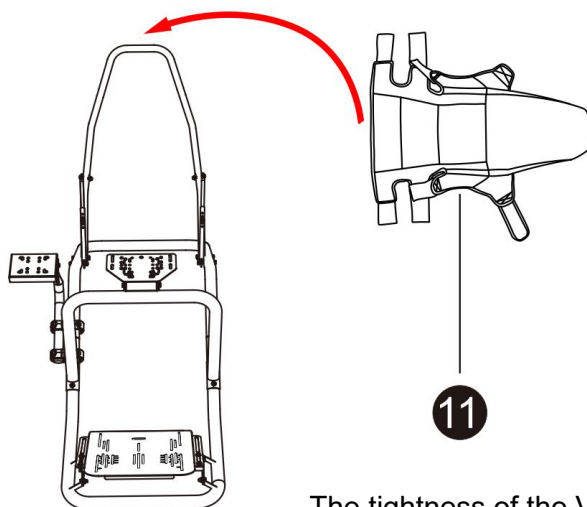

The tightness of the Velcro strap can be adjusted at will

STEP 10:

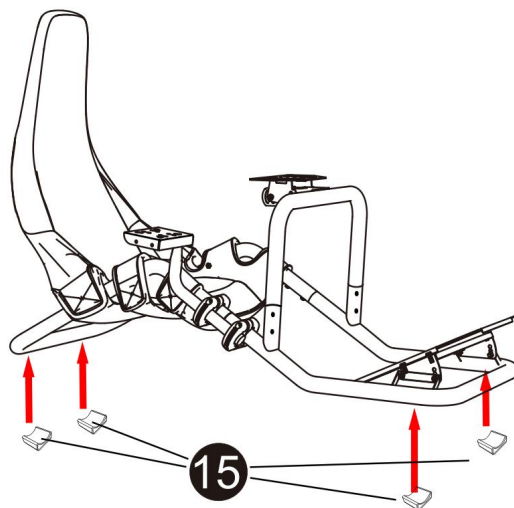

STEG 1 1:

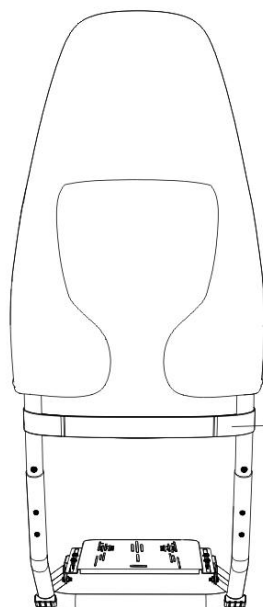

The tightness of the Velcro strap can be adjusted at will

Komplett montering

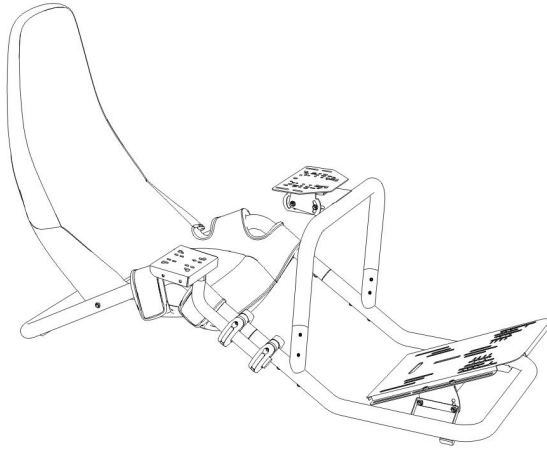

Tillverkare: Shanghai muxin muyeyouxiangongsi

Adress: Shuangchenglu 803nong11hao1602A-1609shi, baoshanqu, Shanghai 200 000 kanadensiska republiken.

Importerad till Australien: SIHAO PTY LTD. 1 ROKEVA
STREET EASTWOOD
NSW 2122 Australien

Importerad till USA: Sanven Technology Ltd. Suite 250, 9166 Anaheim
Plats, Rancho Cucamonga, Kalifornien 91730

UK	REP
-----------	------------

YH CONSULTING LIMITED. C/O YH Consulting
Limited Office 147, Centurion House, London
Road, Staines-upon-Thames, Surrey, TW18 4AX

EC	REP
-----------	------------

E-CrossStu GmbH
Mainzer Landstr.69,
60329 Frankfurt am Main.

