

VEVOR

Affordable. Reliable. Home Improvement.

Laundry Pedestal

Model: S06-2

VEVOR

Affordable. Reliable. Home Improvement.

Laundry Pedestal

Model: S06-2

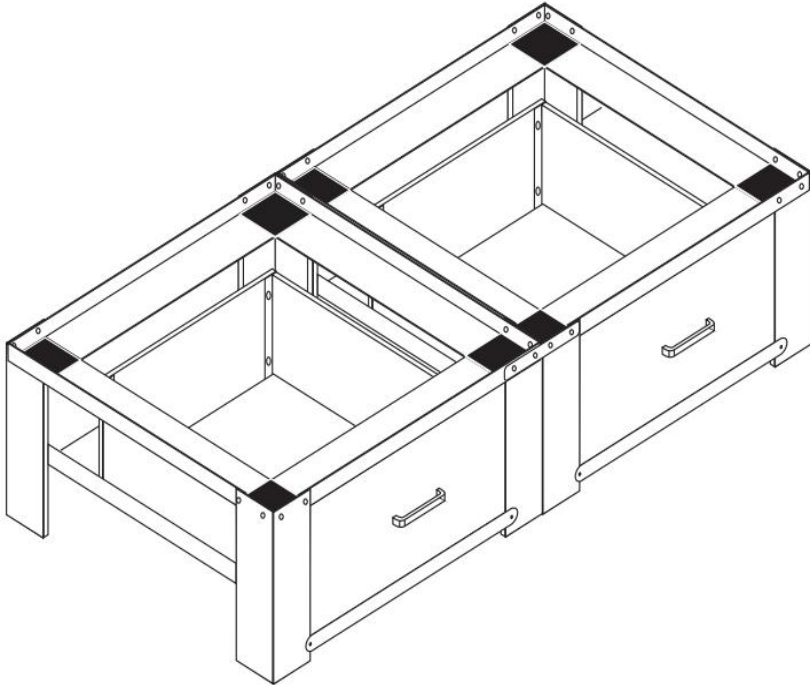



This is the original instruction, please read all manual instructions carefully before operating. VEVOR reserves a clear interpretation of our user manual. The appearance of the product shall be subject to the product you received. Please forgive us that we won't inform you again if there are any technology or software updates on our product.







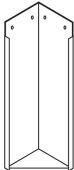

Thank you very much for choosing this product, it should always be handled with care. Please read all of the instructions before using it. The information will help you achieve the best possible results.

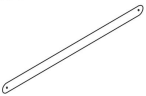

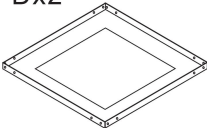
SPECIFICATION

Model	Size	Height	Load of Pedestal	Load of drawer
S06-2	(610-510)×(520-420)mm	11.4in(290mm)	330 (150kg)	5kg

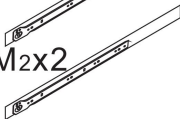
PACKAGE LIST

No.	Name	Picture	Number
1	Column leg A1	A ₁ x2 	2
2	Column leg A2	A ₂ x2 	2
3	Column leg A3	A ₃ x2 	2
4	Column leg A4	A ₄ x2 	2

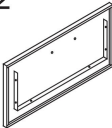
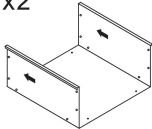
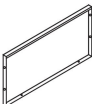
5	Support	Bx4 	4
6	Handle	Yx2 	2
7	Plate	Dx2 	2
8	Screw M4*4	Nx4 	4
9	Pedal	E1x8  E2x8 	8
10	Column track	M1x2  M2x2 	2
11	Drawer track	(7)x2  (8)x2 	2

12	M5*10 screw	Lx80 	80
13	Drawer front plate	Fx2 	2
14	Drawer bottom plate	Jx2 	2
15	Drawer rear plate	Kx2 	2
16	Connector	Gx2 	2
17	Manual	/	1

CAUTIONS

1. Do not allow children to climb on the unit.
2. Keep children and pets away during assembly
3. Please assemble the product in strict accordance with the instructions. Incorrect assembly could be hazardous.
4. Please wear safety goggles and work gloves properly during assembly.
5. Do not try to assemble the product when feeling tired or when under the

influence of alcohol, drugs or medication.

6. Separate and count all parts and hardware.

7. Prepare the following tool: Philips Head Screwdriver.

8. If using power tools, please be careful to slow down and stop when needed.

9. Two people are required for assembly.

10. Follow the intended uses only. Do not sit or stand on the above.

INSTRUCTIONS

Step 1: Place D and A1 A2 A3 A4 as shown in the figure, pay attention to the position of A1 A2 A3 A4, and connect them with L

01

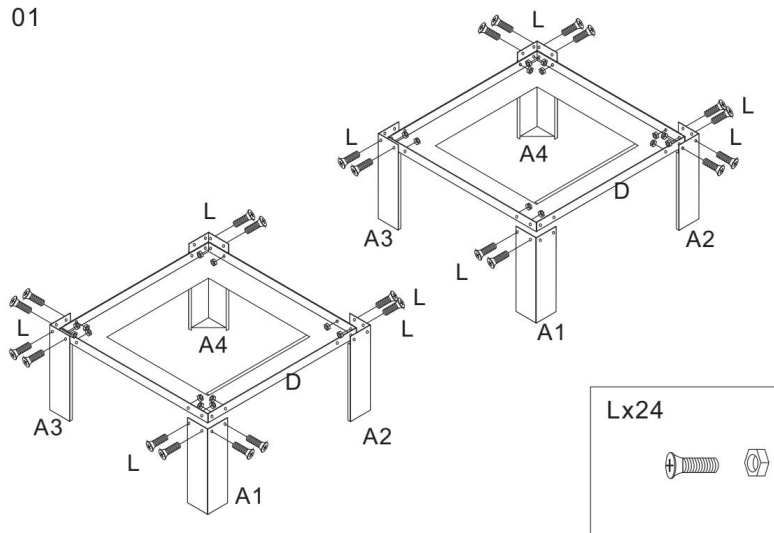

Step 2: Connect M2 to A2 and A4. When installing M2, the white circular wheel on top must be close to A2. When M1 is connected to A1 and A3, the white round wheel on top must be close to A1 when installing M1

02

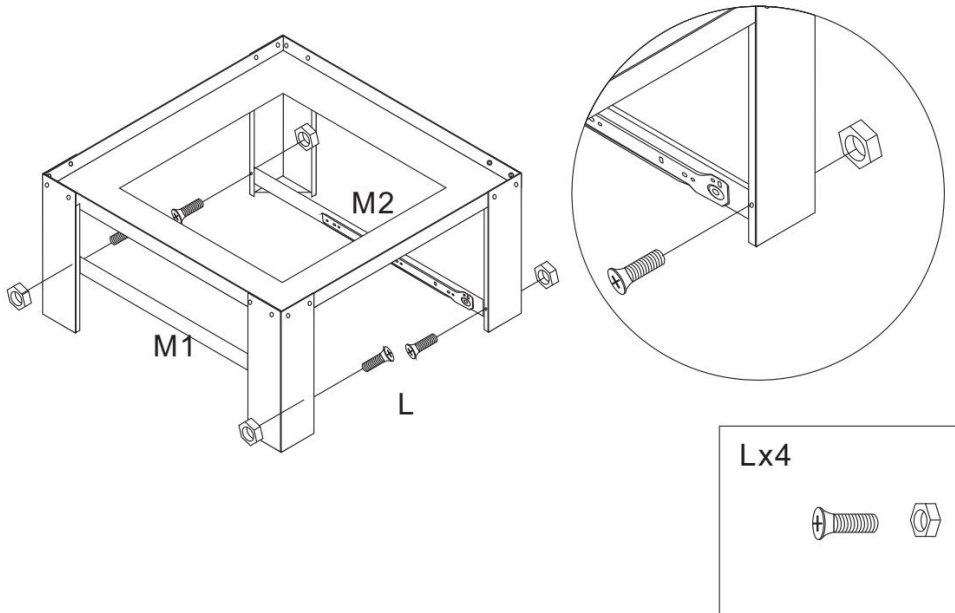

Step 3: Install B

03

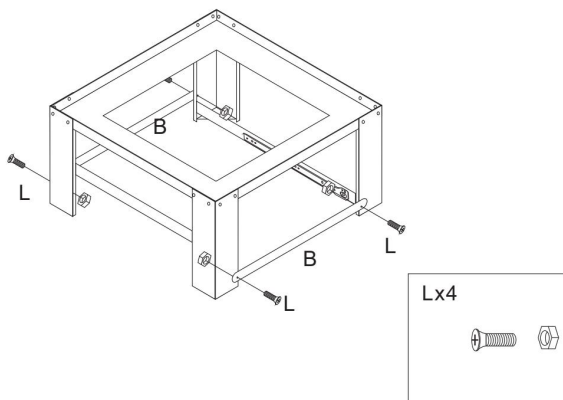

Step 4: Repeat steps 2 and 3, connect the two bases with G

04

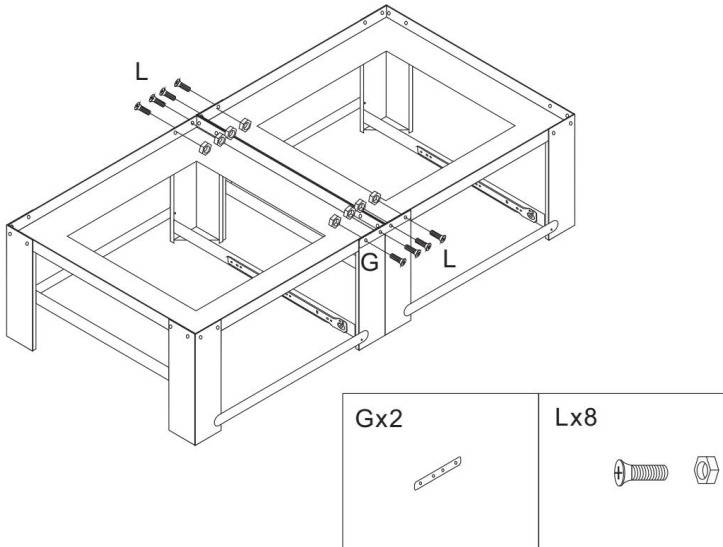

Step 5: Open J to 90°. Connect F to J, pay attention to the connection where F surrounds J. Connect K to J, pay attention to the flat surface of K facing inward. Pay attention to the screw hole position when installing the Y drawer bottom rail.

05

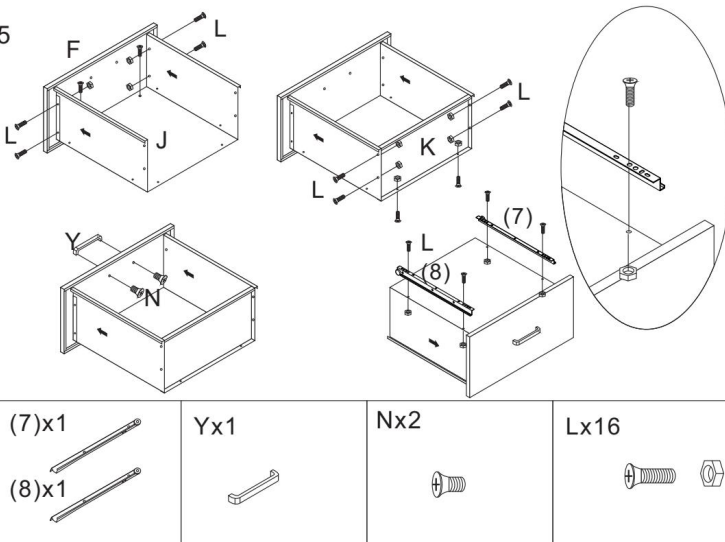

Step 6: Install the drawer

06

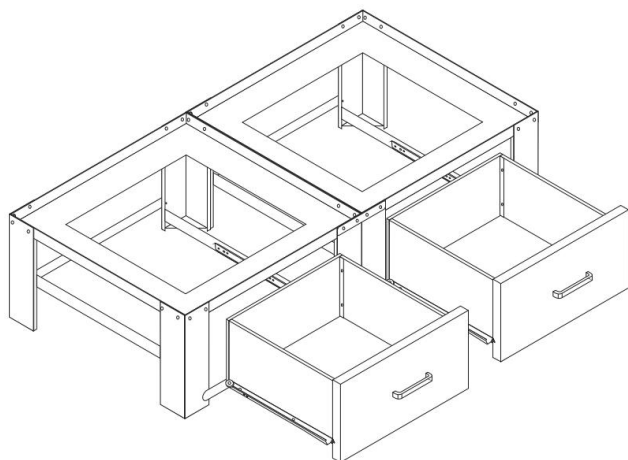

Step 7: Install E1 and E2 as shown in the figure

07

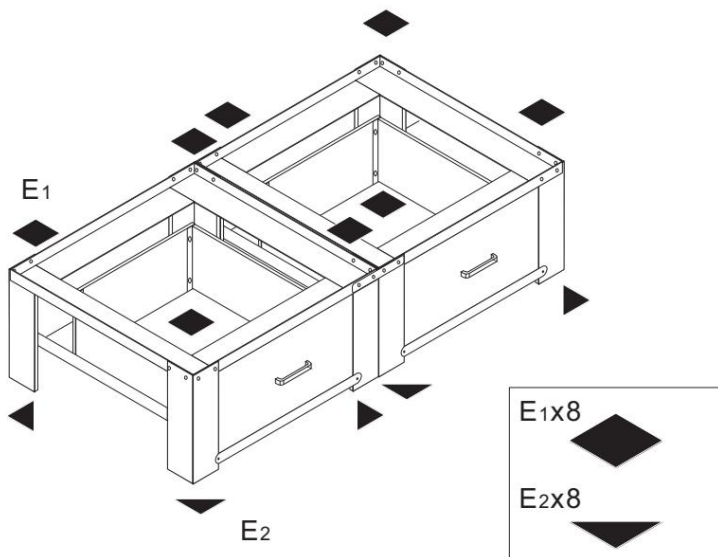

Manufacturer: Shanghaimuxinmuyeyouxiangongsi

Address: Shuangchenglu 803nong11hao1602A-1609shi, baoshanqu, shanghai 200000 CN.

Imported to AUS: SIHAO PTY LTD. 1 ROKEVA STREETEASTWOOD NSW 2122 Australia

Imported to USA: Sanven Technology Ltd. Suite 250, 9166 Anaheim Place, Rancho Cucamonga, CA 91730

UK	REP
-----------	------------

YH CONSULTING LIMITED. C/O YH Consulting Limited Office 147, Centurion House, London Road, Staines-upon-Thames, Surrey, TW18 4AX

EC	REP
-----------	------------

E-CrossStu GmbH
Mainzer Landstr.69,
60329 Frankfurt am Main.



VEVOR

Affordable. Reliable. Home Improvement.

socle à linge

Modèle : S06-2

VEVOR

Affordable. Reliable. Home Improvement.

Laundry Pedestal

Modèle : S06-2

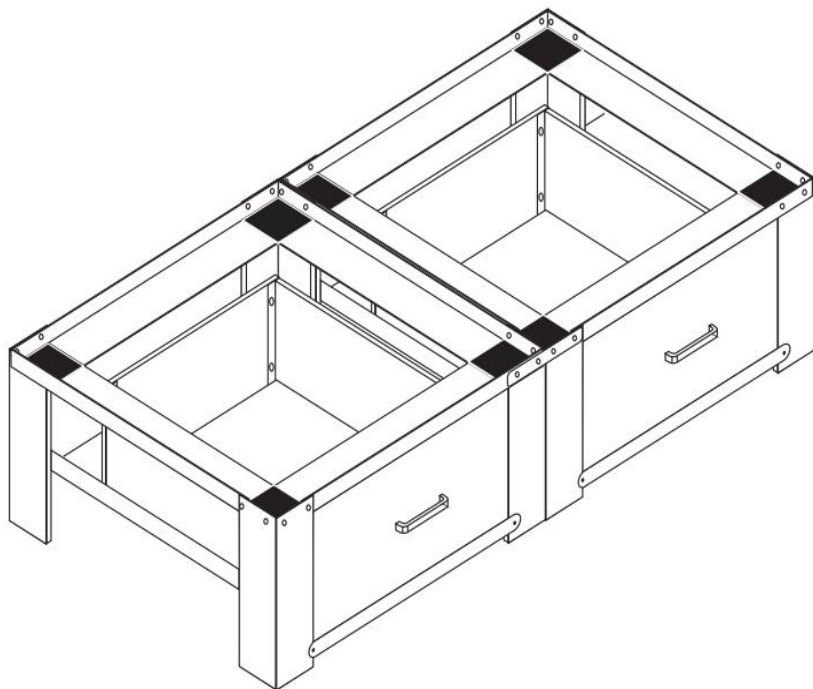

Voici le mode d'emploi original. Veuillez lire attentivement toutes les instructions du manuel avant utilisation. VEVOR se réserve le droit d'interpréter ce manuel à sa guise. L'apparence du produit que vous recevrez peut différer. Nous vous prions de nous excuser si nous ne vous informons pas des mises à jour techniques ou logicielles concernant notre produit.



Merci d'avoir choisi ce produit. Il convient de le manipuler avec précaution. Veuillez lire attentivement la notice avant utilisation. Ces informations vous









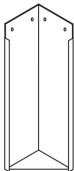

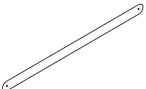
aideront à obtenir les meilleurs résultats possibles.

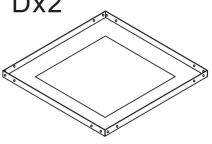

SPECIFICATION

Modèle	Taille	Hauteur	Charge du piédestal	Charge ment du tiroir
S06-2	(610-510) × (520-420) mm	11,4 pouces (290 mm)	330 (150 kg)	5 kg

PACKAGE LIST

Non.	Nom	Image	Nombre
1	Pied de colonne A1	A1x2 	2
2	Pied de colonne A2	A2x2 	2
3	Pied de colonne A3	A3x2 	2
4	Pied de colonne A4	A4x2 	2

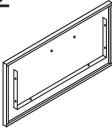
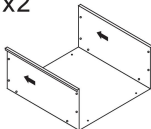
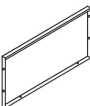
5	Soutien	Bx4 	4
6	Poignée	Yx2 	2
7	Plaque	Dx2 	2
8	Vis M4*4	Nx4 	4
9	Pédale	E1x8  E2x8 	8
10	piste de colonne	M1x2  M2x2 	2
11	Rail de tiroir	(7)x2  (8)x2 	2

12	Vis M5*10	Lx80 	80
13	façade de tiroir	Fx2 	2
14	plaque de fond de tiroir	Jx2 	2
15	plaque arrière du tiroir	Kx2 	2
16	Connecteur	Gx2 	2
17	Manuel	/	1

CAUTIONS

1. Ne laissez pas les enfants grimper sur l'appareil.
2. Tenez les enfants et les animaux domestiques à l'écart pendant l'assemblage.
3. Veuillez assembler le produit en suivant scrupuleusement les instructions.

Un assemblage incorrect peut être dangereux.

4. Veuillez porter correctement des lunettes de sécurité et des gants de travail pendant le montage.
5. N' essayez pas d' assembler le produit si vous êtes fatigué ou sous l' influence de substances.
influence de l'alcool, des drogues ou des médicaments.
6. Séparez et comptez toutes les pièces et la quincaillerie.
7. Préparez l'outil suivant : Tournevis à tête Philips.
8. Si vous utilisez des outils électriques, veuillez à ralentir et à vous arrêter lorsque nécessaire.
nécessaire.
9. Deux personnes sont nécessaires pour l'assemblage.
10. Respectez uniquement l'usage prévu. Ne vous asseyez pas et ne vous tenez pas debout dessus.

INSTRUCTIONS

Étape 1 : Placez D et A1 A2 A3 A4 comme indiqué sur la figure, en faisant attention à leur position, et reliez-les par L.

01

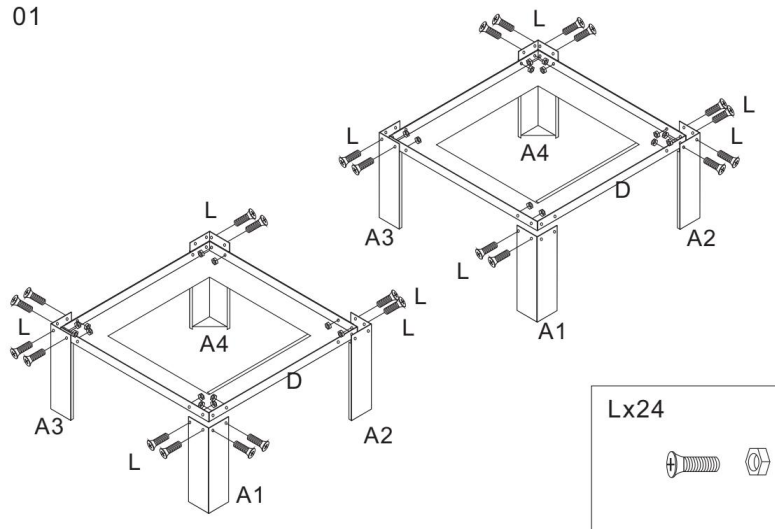

Étape 2 : Connectez M2 à A2 et A4. Lors de l' installation de M2, la molette blanche située sur le dessus doit être proche de A2. Lors de l' installation de M1, connectez la molette blanche située sur le dessus de A1 à A3. La molette blanche située sur le dessus de M1 doit être proche de A1.

02

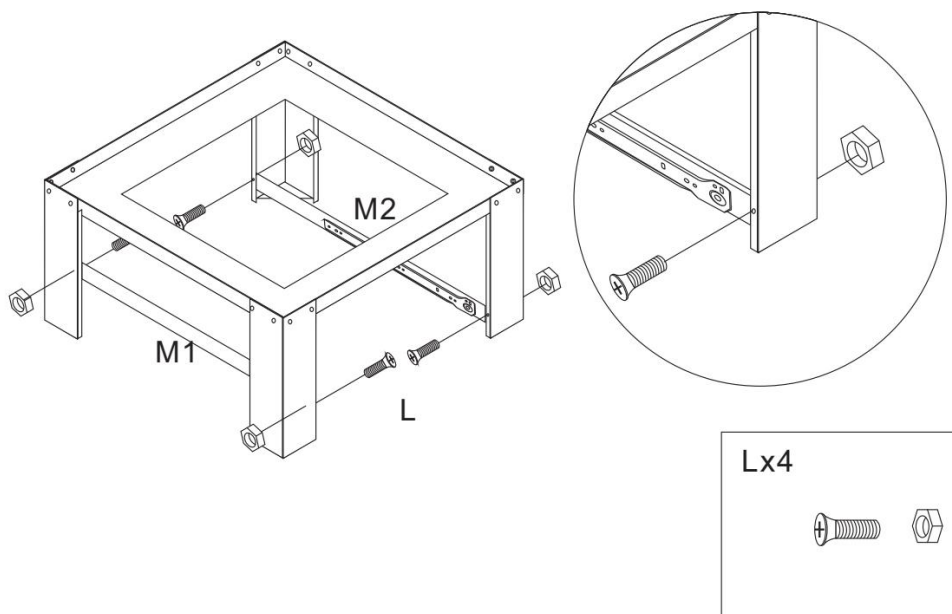

Étape 3 : Installer B

03

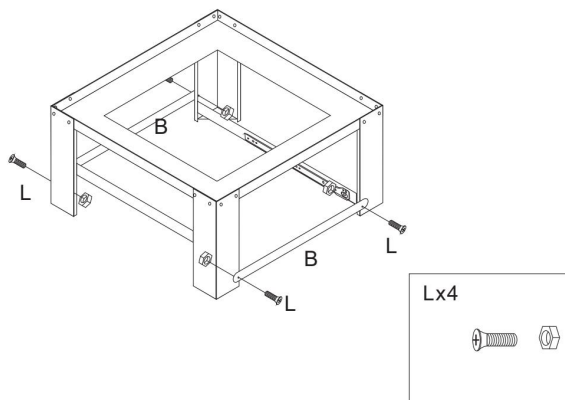

Étape 4 : Répétez les étapes 2 et 3, reliez les deux bases avec G

04

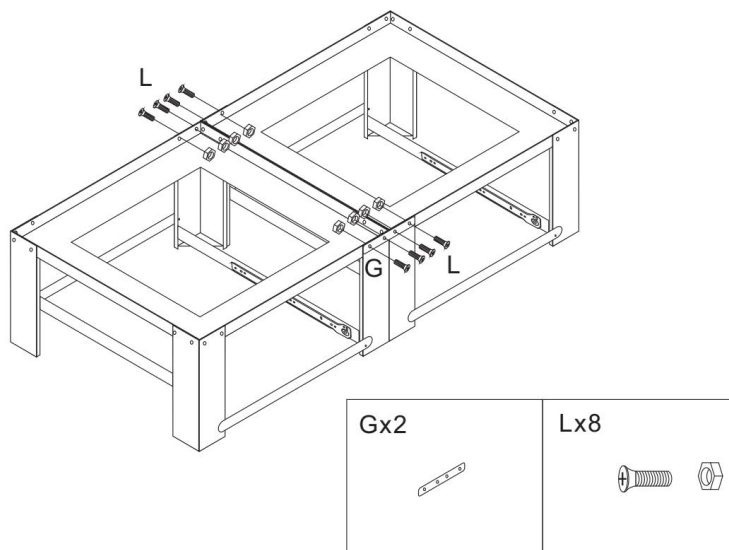

Étape 5 : Ouvrez J à 90° . Raccordez F à J en veillant à ce que F entoure J. Raccordez K à J en orientant la surface plane de K vers l' intérieur. Lors de l' installation du rail inférieur du tiroir Y, faites attention à la position des

trous de vis.

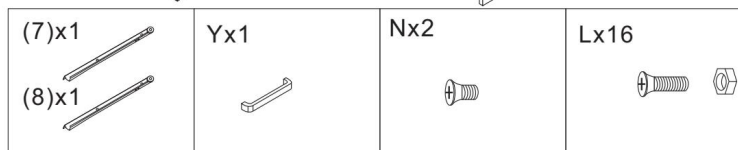
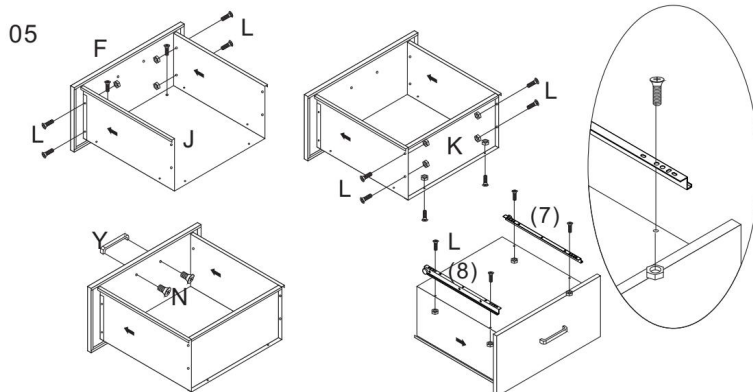

Étape 6 : Installez le tiroir

06

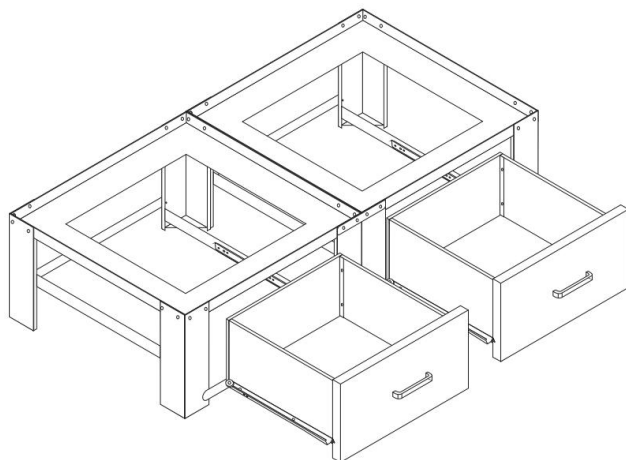

Étape 7 : Installez E1 et E2 comme indiqué sur la figure

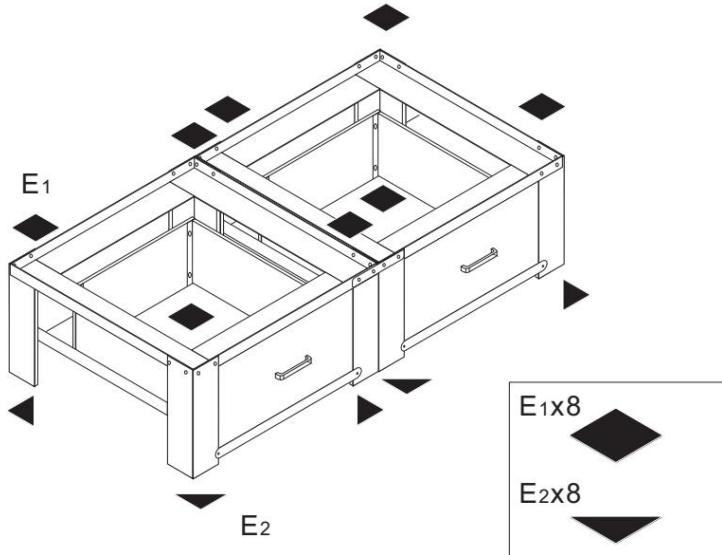

Fabricant : Shanghai muxinmuyeyouxiangongsi

Adresse : Shuangchenglu 803nong11hao1602A-1609shi, baoshanqu, Shanghai 200000 CN.

Importé en Australie : SIHAO PTY LTD. 1 ROKEVA STREET EASTWOOD

NSW 2122 Australie

Importé aux États-Unis : Sanven Technology Ltd., Suite 250, 9166 Anaheim

Rancho Cucamonga, CA 91730

UK	REP
-----------	------------

YH CONSULTING LIMITED. C/O YH Consulting
Limited Office 147, Centurion House, London
Road, Staines-upon-Thames, Surrey, TW18 4AX

EC	REP
-----------	------------

E-CrossStu GmbH
Mainzer Landstr.69,
60329 Frankfurt am Main.



VEVOR

Affordable. Reliable. Home Improvement.

Wäscheständer

Modell: S06-2

Modell: S06-2

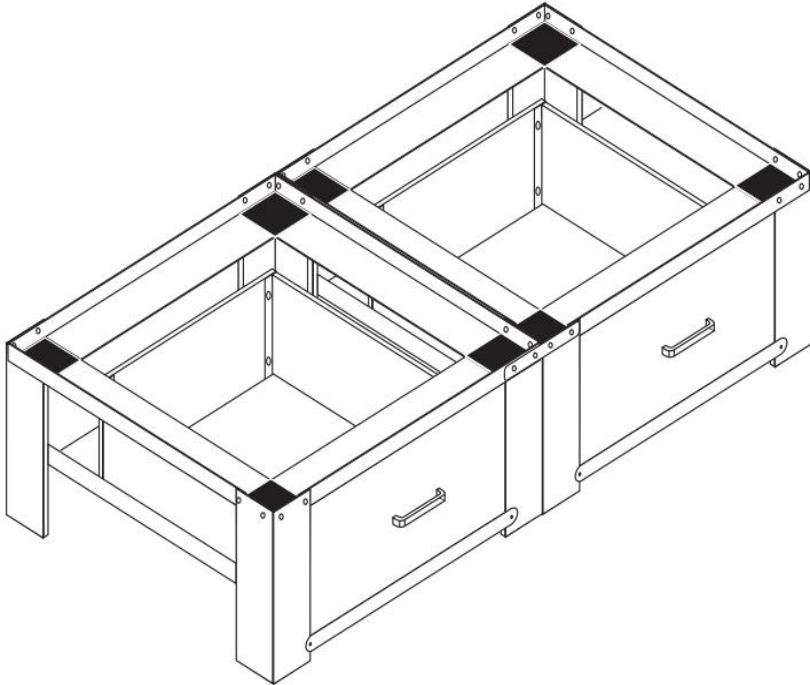

Dies ist die Originalanleitung. Bitte lesen Sie die gesamte Bedienungsanleitung vor der Inbetriebnahme sorgfältig durch. VEVOR behält sich die Auslegung der Bedienungsanleitung vor. Das Aussehen des Produkts kann von dem gelieferten Produkt abweichen. Wir bitten um Verständnis, dass wir Sie nicht erneut über etwaige Technologie- oder Software-Updates informieren werden .



Vielen Dank, dass Sie sich für dieses Produkt entschieden haben. Bitte behandeln Sie es stets mit Sorgfalt. Lesen Sie vor Gebrauch bitte die









gesamte Gebrauchsanweisung. Die Informationen werden Ihnen helfen, bestmögliche Ergebnisse zu erzielen.

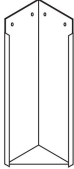
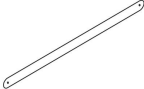

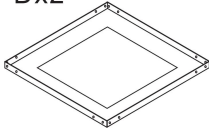

SPECIFICATION

Modell	Größe	Höhe	Sockellast	Schubladenladung
S06-2	(610-510) × (520-420) mm	11,4 Zoll (290 mm)	330 (150 kg)	5 kg

PACKAGE LIST

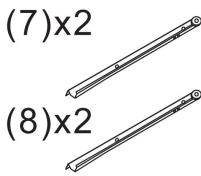
NEIN.	Name	Bild	Nummer
1	Säulenbein A1	A1x2 	2
2	Säulenbein A2	A2x2 	2
3	Säulenbein A3	A3x2 	2

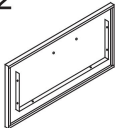
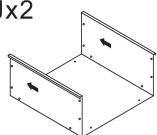
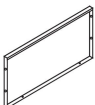
4	Säulenbein A4	A4x2 	2
5	Unterstützung	Bx4 	4
6	Handhaben	Yx2 	2
7	Platte	Dx2 	2
8	Schraube M4*4	Nx4 	4
9	Pedal	E1x8  E2x8 	8
10	Säulenspur	M1x2  M2x2 	2

11	Schubladenschiene	(7)x2 	2
12	M5*10 Schraube	Lx80 	80
13	Schubladenfrontplatte	Fx2 	2
14	Schubladenbodenplatte	Jx2 	2
15	Schubladenrückwand	Kx2 	2
16	Anschluss	Gx2 	2
17	Handbuch	/	1

CAUTIONS

1. Kindern ist es nicht gestattet, auf das Gerät zu klettern.
2. Kinder und Haustiere während der Montage fernhalten.
3. Bitte montieren Sie das Produkt genau nach Anleitung.
Eine unsachgemäße Montage kann gefährlich sein.
4. Bitte tragen Sie während der Montage eine Schutzbrille und Arbeitshandschuhe ordnungsgemäß.
5. Versuchen Sie nicht, das Produkt zusammenzubauen, wenn Sie müde sind oder unter Alkoholeinfluss stehen.
Einfluss von Alkohol, Drogen oder Medikamenten.
6. Alle Teile und Hardware aussortieren und zählen.
7. Bereiten Sie folgendes Werkzeug vor: Kreuzschlitzschraubendreher.
8. Bei der Verwendung von Elektrowerkzeugen ist darauf zu achten, die Geschwindigkeit zu reduzieren und anzuhalten, wenn...
benötigt.
9. Für die Montage werden zwei Personen benötigt.
10. Bitte nur für den vorgesehenen Zweck verwenden. Nicht darauf sitzen oder stehen.

INSTRUCTIONS

Schritt 1: Platzieren Sie D und A1 A2 A3 A4 wie in der Abbildung gezeigt, achten Sie dabei auf die Position von A1 A2 A3 A4 und verbinden Sie diese mit L.

01

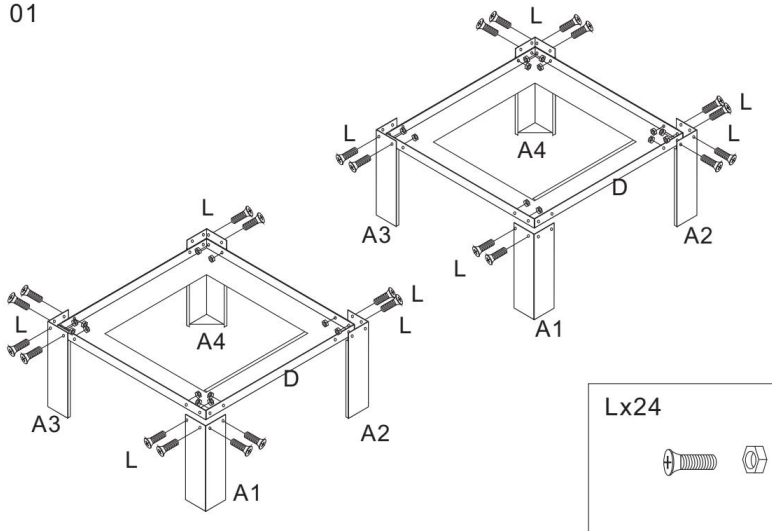

Schritt 2: Verbinden Sie M2 mit A2 und A4. Achten Sie bei der Montage von M2 darauf, dass sich das weiße runde Rad oben in der Nähe von A2 befindet. Wenn M1 mit A1 und A3 verbunden wird, muss sich das weiße runde Rad oben bei der Montage von M1 in der Nähe von A1 befinden.

02

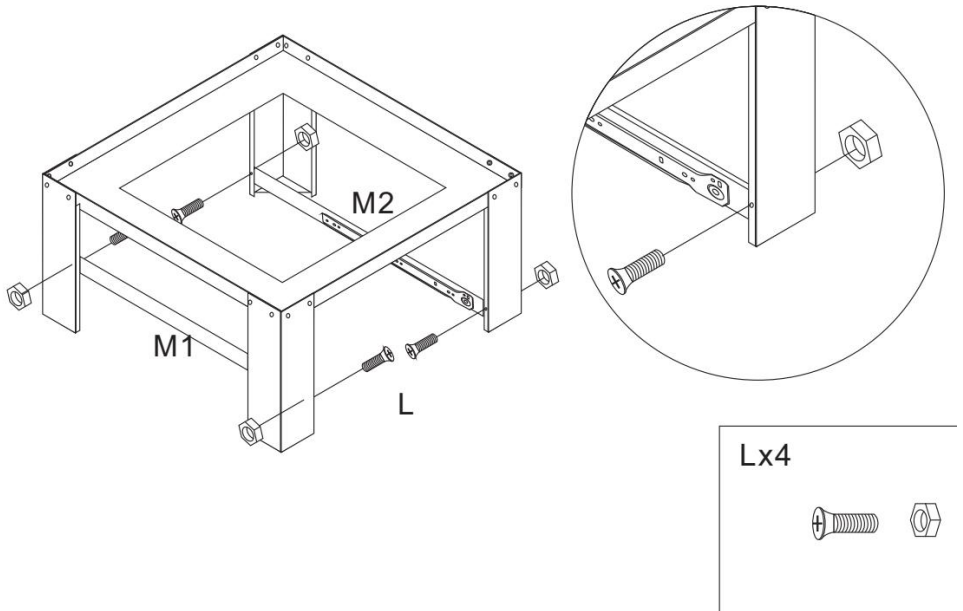

Schritt 3: Installieren Sie B

03

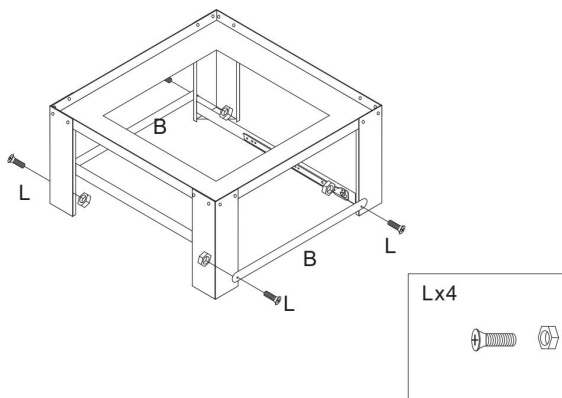

Schritt 4: Wiederholen Sie die Schritte 2 und 3 und verbinden Sie die beiden Basen mit G.

04

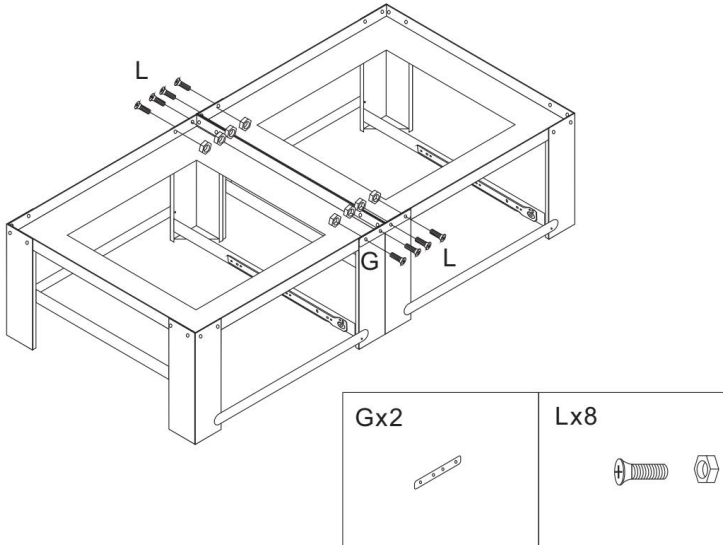

Schritt 5: Öffnen Sie J um 90°. Verbinden Sie F mit J und achten Sie dabei auf die Stelle, an der F J umschließt. Verbinden Sie K mit J und achten Sie darauf, dass die ebene Fläche von K nach innen zeigt. Achten Sie beim Einbau der unteren Schiene der Y-Schublade auf die Position der Schraubenlöcher.

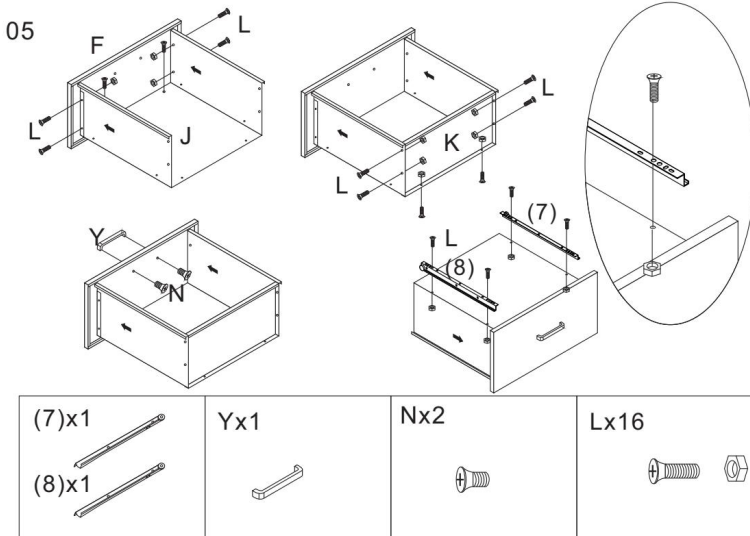

Schritt 6: Schublade einbauen

06

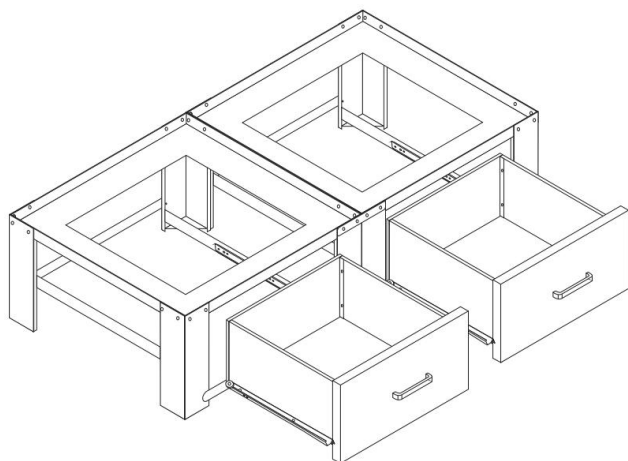

Schritt 7: Installieren Sie E1 und E2 wie in der Abbildung gezeigt.

07

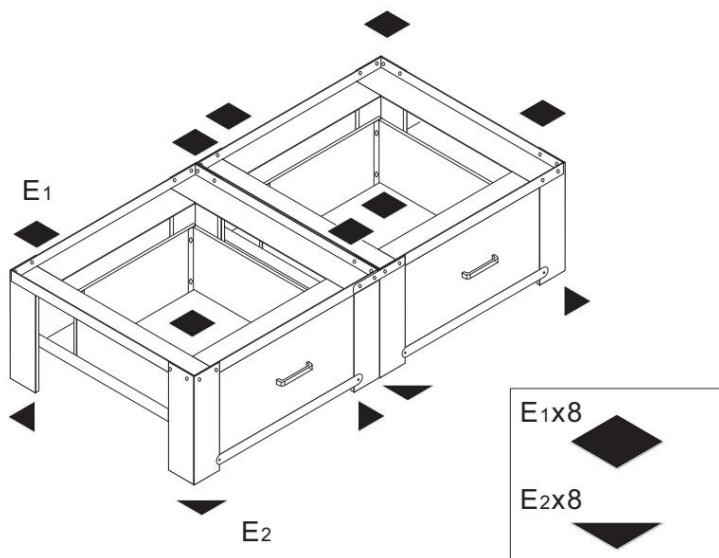

Hersteller: Shanghai muxinmuyeyouxiangongsi

Adresse: Shuangchenglu 803nong11hao1602A-1609shi, baoshanqu, Shanghai 200000 CN.

Importiert nach Australien: SIHAO PTY LTD. 1 ROKEVA STREET, EASTWOOD

NSW 2122 Australien

Importiert in die USA: Sanven Technology Ltd. Suite 250, 9166 Anaheim Ort, Rancho Cucamonga, CA 91730

UK	REP
-----------	------------

YH CONSULTING LIMITED. C/O YH Consulting Limited Office 147, Centurion House, London Road, Staines-upon-Thames, Surrey, TW18 4AX

EC	REP
-----------	------------

E-CrossStu GmbH
Mainzer Landstr.69,
60329 Frankfurt am Main.



VEVOR

Affordable. Reliable. Home Improvement.

Piedistallo per lavanderia

Modello: S06-2

VEVOR

Affordable. Reliable. Home Improvement.

Laundry Pedestal

Modello: S06-2

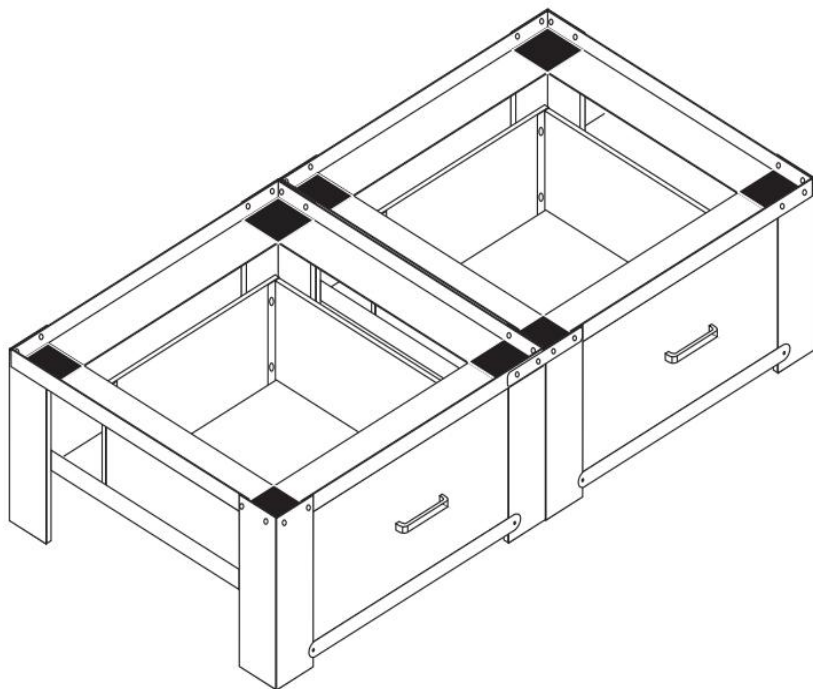

Queste sono le istruzioni originali, si prega di leggere attentamente tutte le istruzioni del manuale prima dell'uso. VEVOR si riserva la piena interpretazione del proprio manuale utente. L'aspetto del prodotto dipenderà dal prodotto ricevuto. Vi preghiamo di scusarci se non vi informeremo più in caso di aggiornamenti tecnologici o software sul nostro prodotto.



Grazie mille per aver scelto questo prodotto. Maneggetelo sempre con cura. Leggete attentamente le istruzioni prima di utilizzarlo. Le informazioni









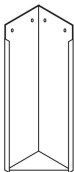

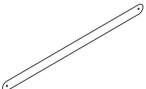
ti aiuteranno a raggiungere i migliori risultati possibili.

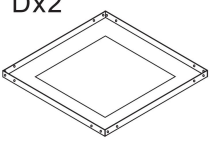

SPECIFICATION

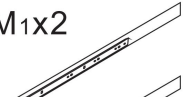
Modello	Misurare	Altezza	Carico del piedistallo	Carico del cassetto
S06-2	(610-510) × (520-420) millimetri	11,4 pollici (290 mm)	330 (150 kg)	5 kg

PACKAGE LIST

NO.	Nome	Immagine	Numero
1	Gamba della colonna A1	A1x2 	2
2	Gamba della colonna A2	A2x2 	2
3	Gamba della colonna A3	A3x2 	2
4	Gamba a colonna A4	A4x2 	2

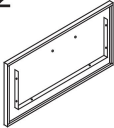
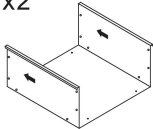
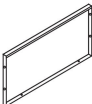
5	Supporto	Bx4 	4
6	Maniglia	Yx2 	2
7	Piatto	Dx2 	2
8	Vite M4*4	Nx4 	4
9	Pedale	E1x8  E2x8 	8
10	Binario a colonna	M1x2  M2x2 	2
11	Binario del cassetto	(7)x2  (8)x2 	2

12	Vite M5*10	Lx80 	80
13	Piastra frontale del cassetto	Fx2 	2
14	Piastra inferiore del cassetto	Jx2 	2
15	Piastra posteriore del cassetto	Kx2 	2
16	Connettore	Gx2 	2
17	Manuale	/	1

CAUTIONS

1. Non permettere ai bambini di arrampicarsi sull'unità.
2. Tenere lontani bambini e animali domestici durante il montaggio
3. Si prega di montare il prodotto seguendo scrupolosamente le istruzioni. Un montaggio non corretto potrebbe rivelarsi pericoloso.
4. Durante il montaggio, indossare occhiali protettivi e guanti da lavoro.
5. Non tentare di montare il prodotto quando ci si sente stanchi o sotto

l'effetto

sotto l'effetto di alcol, droghe o farmaci.

6. Separare e contare tutte le parti e l'hardware.

7. Preparare il seguente strumento: cacciavite a croce.

8. Se si utilizzano utensili elettrici, fare attenzione a rallentare e fermarsi quando necessario.

9. Per il montaggio sono necessarie due persone.

10. Attenersi esclusivamente agli usi previsti. Non sedersi o salire in piedi sui punti sopra indicati.

INSTRUCTIONS

Fase 1: Posizionare D e A1 A2 A3 A4 come mostrato nella figura, prestare attenzione alla posizione di A1 A2 A3 A4 e collegarli con L

01

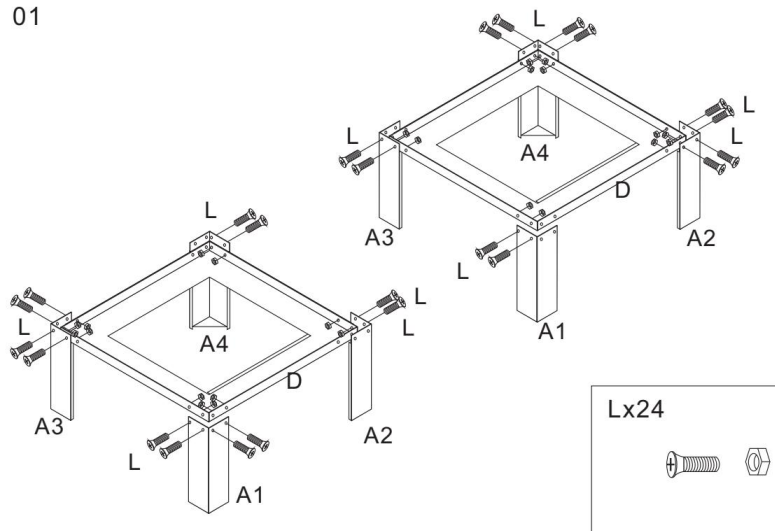

Fase 2: Collegare M2 ad A2 e A4. Quando si installa M2, la rotella bianca

circolare in alto deve essere vicina ad A2. Quando M1 è collegato ad A1 e A3, la rotella bianca circolare in alto deve essere vicina ad A1 quando si installa M1.

02

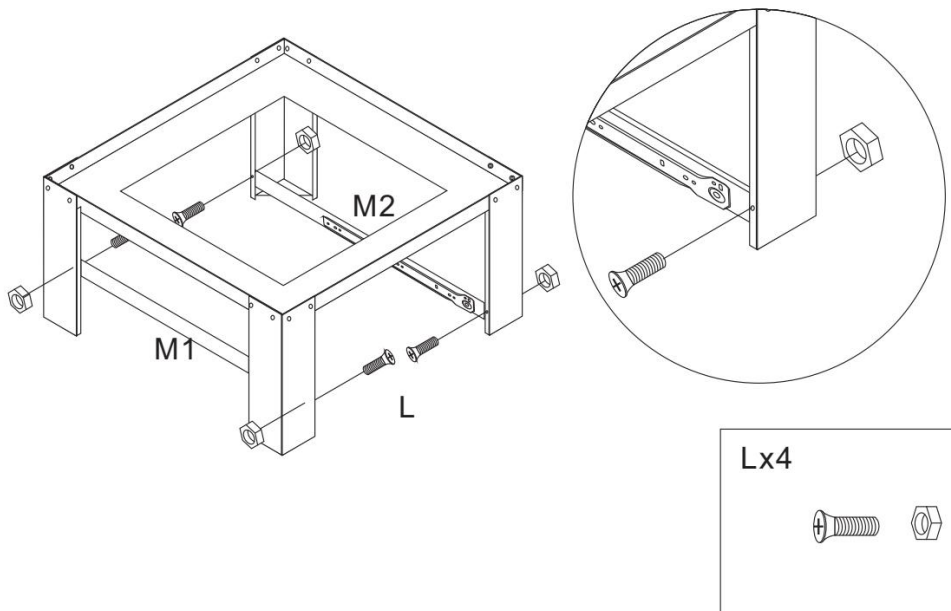

Passaggio 3: installare B

03

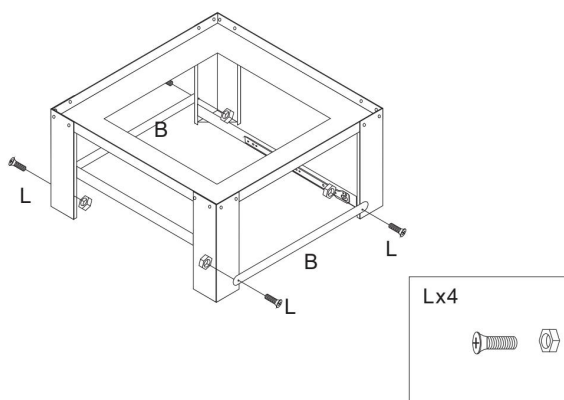

Passaggio 4: ripetere i passaggi 2 e 3, collegare le due basi con G

04

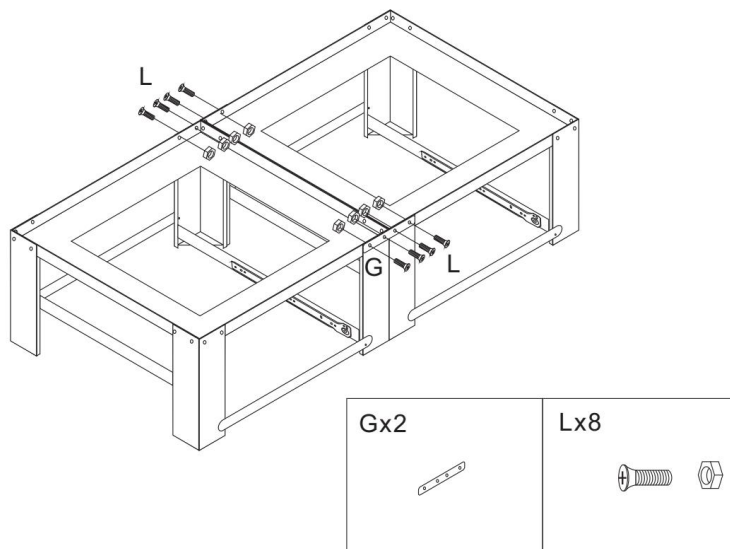

Fase 5: Aprire J a 90° . Collegare F a J, prestando attenzione al punto in cui F circonda J. Collegare K a J, prestando attenzione alla superficie piana di K rivolta verso l'interno. Prestare attenzione alla posizione dei fori delle viti durante l'installazione della guida inferiore del cassetto Y.

05

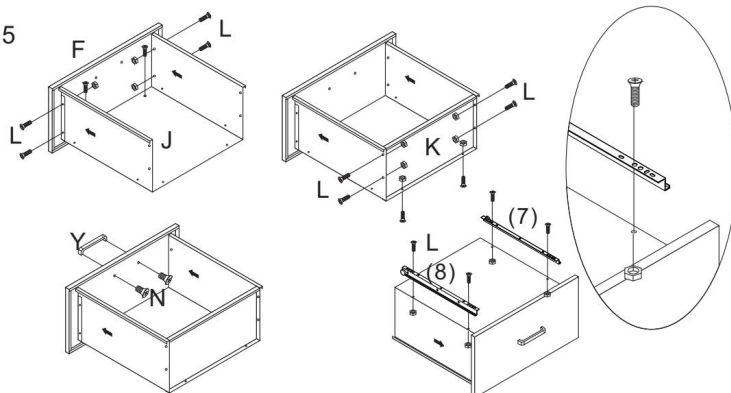

<p>(7)x1</p> <p>(8)x1</p>	<p>Yx1</p>	<p>Nx2</p>	<p>Lx16</p>
---------------------------	------------	------------	-------------

Fase 6: Installare il cassetto

06

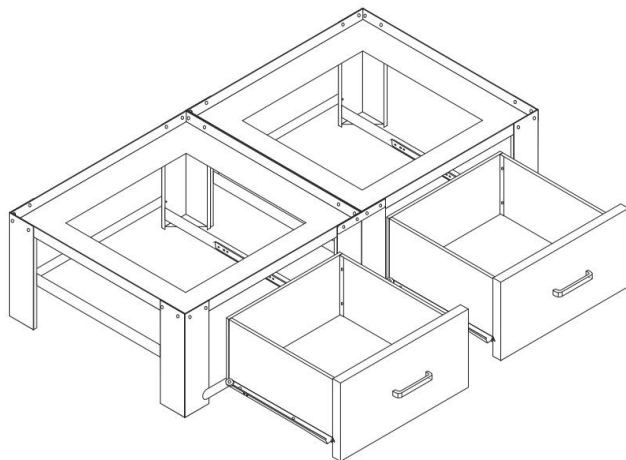

Fase 7: Installare E1 ed E2 come mostrato nella figura

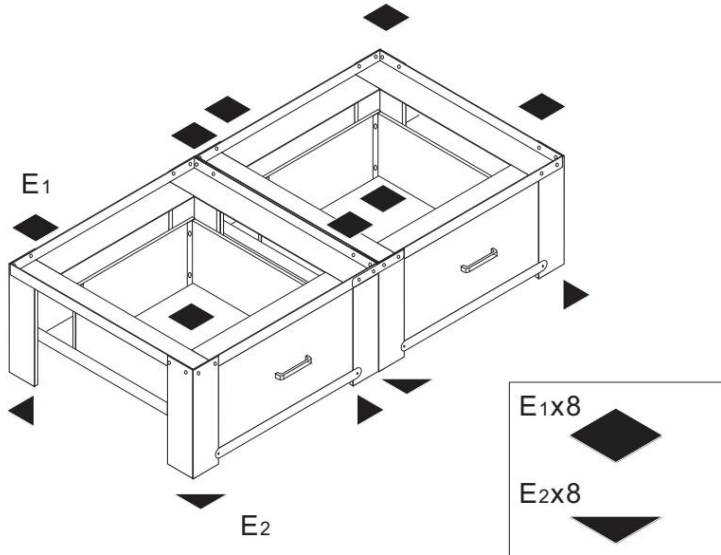

Produttore: Shanghai muxinmuyeyouxiangongsi

Indirizzo: Shuangchenglu 803nong11hao1602A-1609shi, baoshanqu, Shanghai 200000 CN.

Importato in AUS: SIHAO PTY LTD. 1 ROKEVA STREET EASTWOOD
Nuovo Galles del Sud 2122 Australia

Importato negli USA: Sanven Technology Ltd. Suite 250, 9166 Anaheim
Luogo, Rancho Cucamonga, CA 91730

UK	REP
-----------	------------

YH CONSULTING LIMITED. C/O YH Consulting
Limited Office 147, Centurion House, London
Road, Staines-upon-Thames, Surrey, TW18 4AX

EC	REP
-----------	------------

E-CrossStu GmbH
Mainzer Landstr.69,
60329 Frankfurt am Main.



VEVOR

Affordable. Reliable. Home Improvement.

Pedestal de lavandería

Modelo: S06-2

Modelo: S06-2

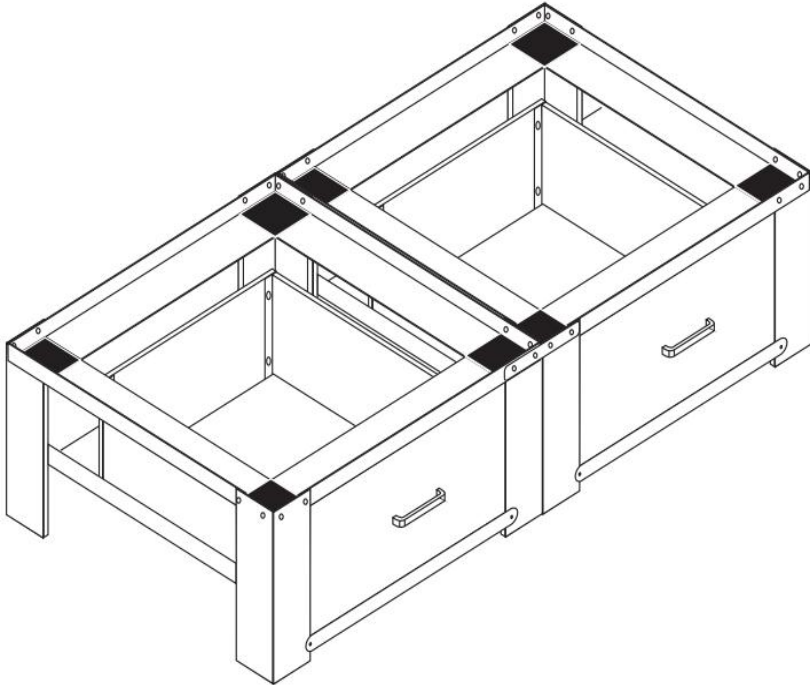

Estas son las instrucciones originales; lea atentamente todas las instrucciones del manual antes de utilizarlo. VEVOR se reserva el derecho de interpretar este manual de usuario. La apariencia del producto dependerá del producto que haya recibido. Le rogamos que nos disculpe si no le informamos de nuevo si hay actualizaciones tecnológicas o de software en nuestro producto.



Muchas gracias por elegir este producto. Manéjelo siempre con cuidado. Lea todas las instrucciones antes de usarlo. La información le ayudará a







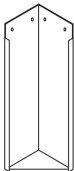

conseguir los mejores resultados posibles.

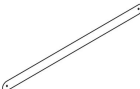

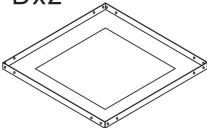
SPECIFICATION

Modelo	Tamaño	Altura	Carga del pedestal	Carga del cajón
S06-2	(610-510) × (520-420) mm	11,4 pulgadas (290 mm)	330 (150 kg)	5 kilos

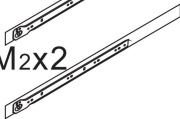
PACKAGE LIST

No.	Nombre	Imagen	Número
1	Pata de columna A1	A1x2 	2
2	Pata de columna A2	A2x2 	2
3	Pata de columna A3	A3x2 	2
4	Pata de columna A4	A4x2 	2

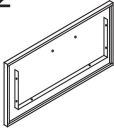
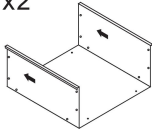
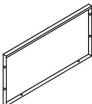
5	Apoyo	Bx4 	4
6	Manejar	Yx2 	2
7	Lámina	Dx2 	2
8	Tornillo M4*4	Nx4 	4
9	Pedal	E1x8  E2x8 	8
10	Pista de columnas	M1x2  M2x2 	2
11	Riel de cajón	(7)x2  (8)x2 	2

12	Tornillo M5*10	Lx80 	80
13	Placa frontal del cajón	Fx2 	2
14	Placa inferior del cajón	Jx2 	2
15	Placa trasera del cajón	Kx2 	2
16	Conector	Gx2 	2
17	Manual	/	1

CAUTIONS

1. No permita que los niños se suban a la unidad.
2. Mantenga a los niños y las mascotas alejados durante el montaje.
3. Por favor, monte el producto siguiendo estrictamente las instrucciones. Un montaje incorrecto podría ser peligroso.
4. Utilice gafas de seguridad y guantes de trabajo adecuadamente durante el montaje.

5. No intente ensamblar el producto cuando se sienta cansado o bajo la influencia del alcohol.
6. Separe y cuente todas las piezas y el hardware.
7. Prepare la siguiente herramienta: Destornillador de cabeza Philips.
8. Si utiliza herramientas eléctricas, tenga cuidado de reducir la velocidad y detenerse cuando necesario.
9. Se necesitan dos personas para el montaje.
10. Siga únicamente los usos previstos. No se sienta ni se pare sobre lo anterior.

INSTRUCTIONS

Paso 1: Coloque D y A1 A2 A3 A4 como se muestra en la figura, preste atención a la posición de A1 A2 A3 A4 y conéctelos con L

01

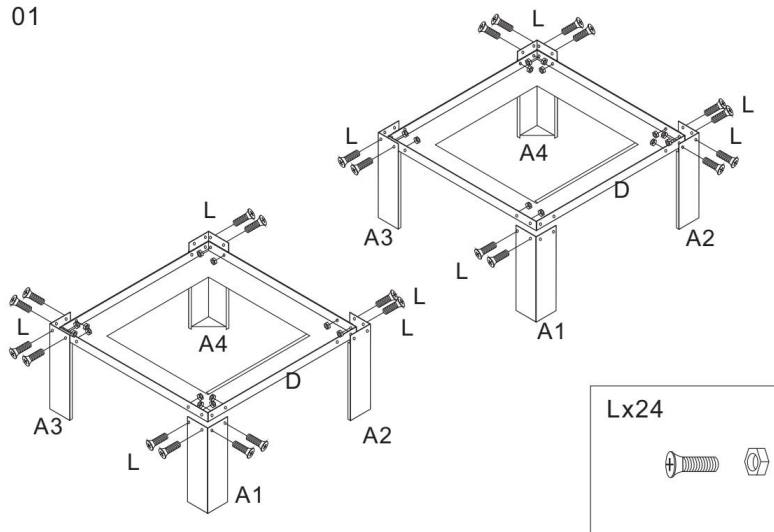

Paso 2: Conecte M2 a A2 y A4. Al instalar M2, la rueda circular blanca superior debe estar cerca de A2. Al conectar M1 a A1 y A3, la rueda circular blanca superior debe estar cerca de A1 al instalar M1.

02

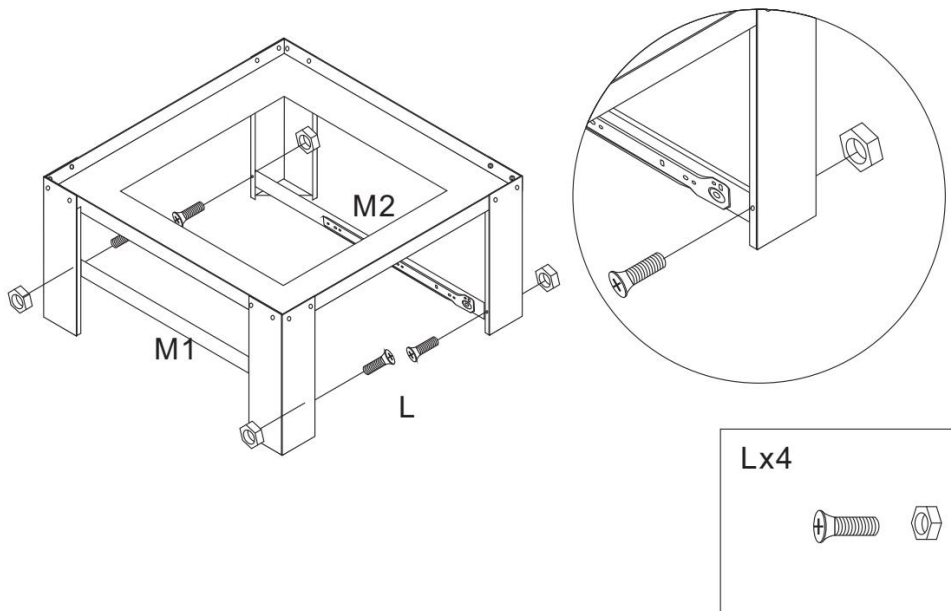

Paso 3: Instalar B

03

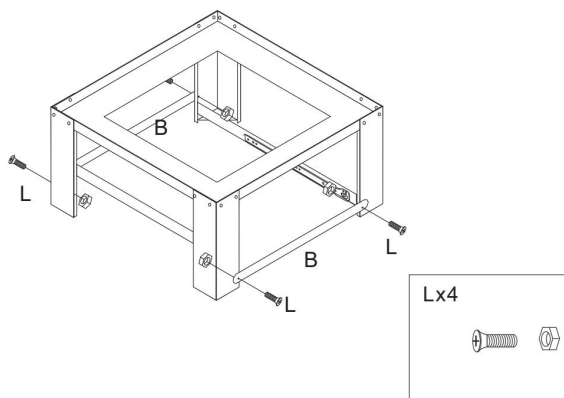

Paso 4: Repita los pasos 2 y 3, conecte las dos bases con G

04

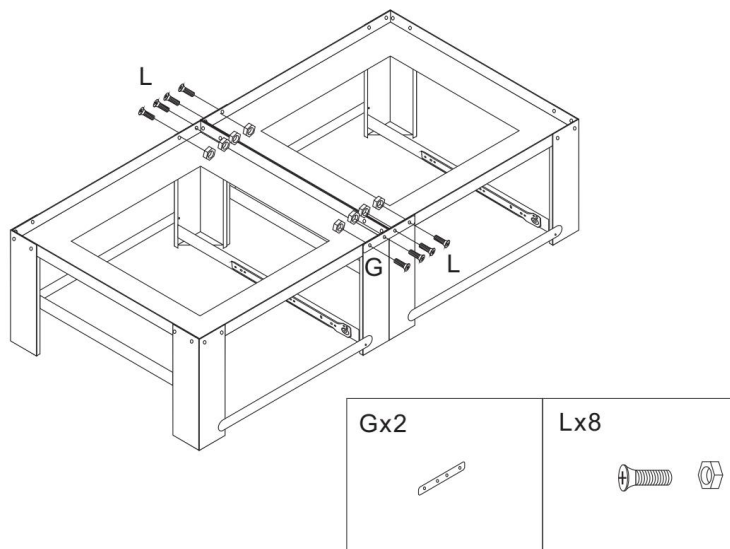

Paso 5: Abra J a 90° . Conecte F a J, prestando atención a la conexión donde F rodea a J. Conecte K a J, prestando atención a la superficie plana de K orientada hacia adentro. Preste atención a la posición del orificio del tornillo al instalar el riel inferior del cajón Y.

05

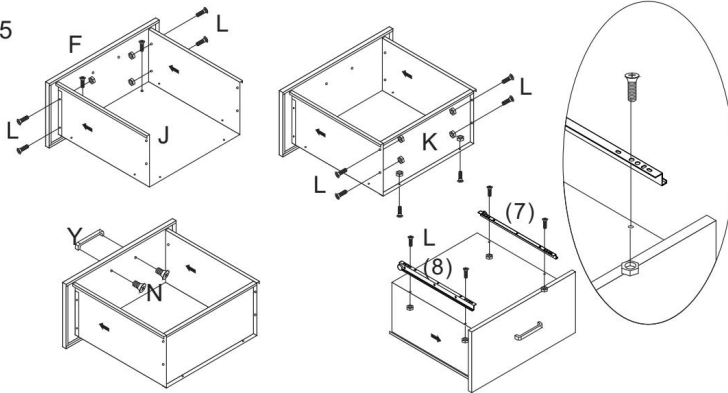

(7)x1 	Yx1 	Nx2 	Lx16
(8)x1 			

Paso 6: Instalar el cajón

06

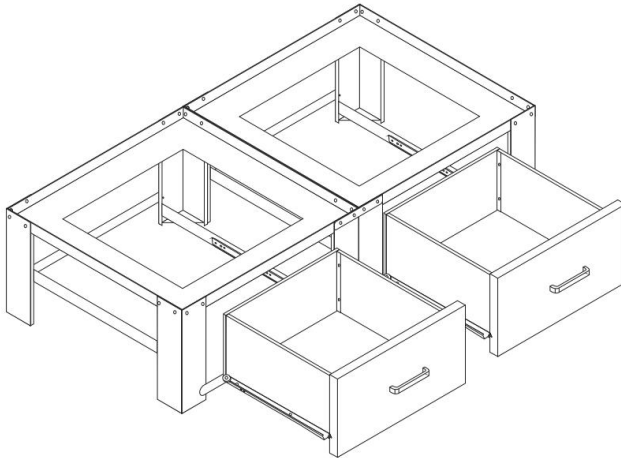

Paso 7: Instale E1 y E2 como se muestra en la figura

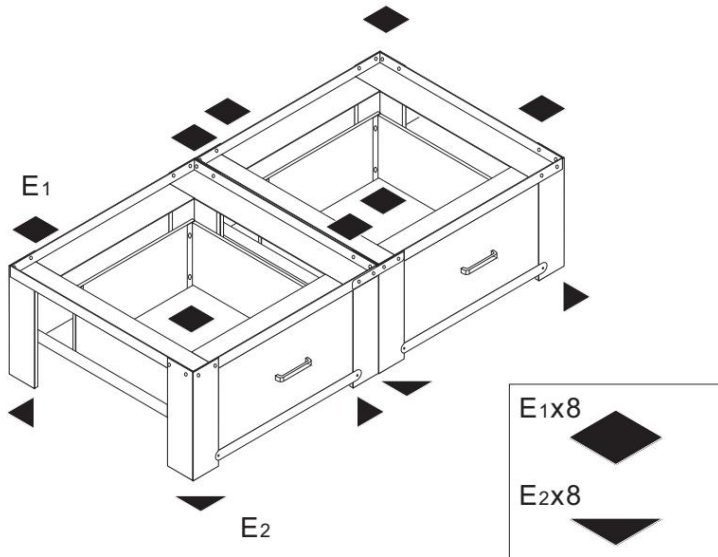

Fabricante: Shanghai muxinmuyeyouxiangongsi

Dirección: Shuangchenglu 803nong11hao1602A-1609shi, baoshanqu, Shanghái 200000 CN.

Importado a AUS: SIHAO PTY LTD. 1 ROKEVA STREET EASTWOOD NSW 2122 Australia

Importado a EE. UU.: Sanven Technology Ltd. Suite 250, 9166 Anaheim Lugar, Rancho Cucamonga, CA 91730

UK	REP	YH CONSULTING LIMITED. C/O YH Consulting Limited Office 147, Centurion House, London Road, Staines-upon-Thames, Surrey, TW18 4AX
-----------	------------	--

EC	REP	E-CrossStu GmbH Mainzer Landstr.69, 60329 Frankfurt am Main.
-----------	------------	--



VEVOR

Affordable. Reliable. Home Improvement.

Postument pralniczy

Model: S06-2

VEVOR

Affordable. Reliable. Home Improvement.

Laundry Pedestal

Model: S06-2

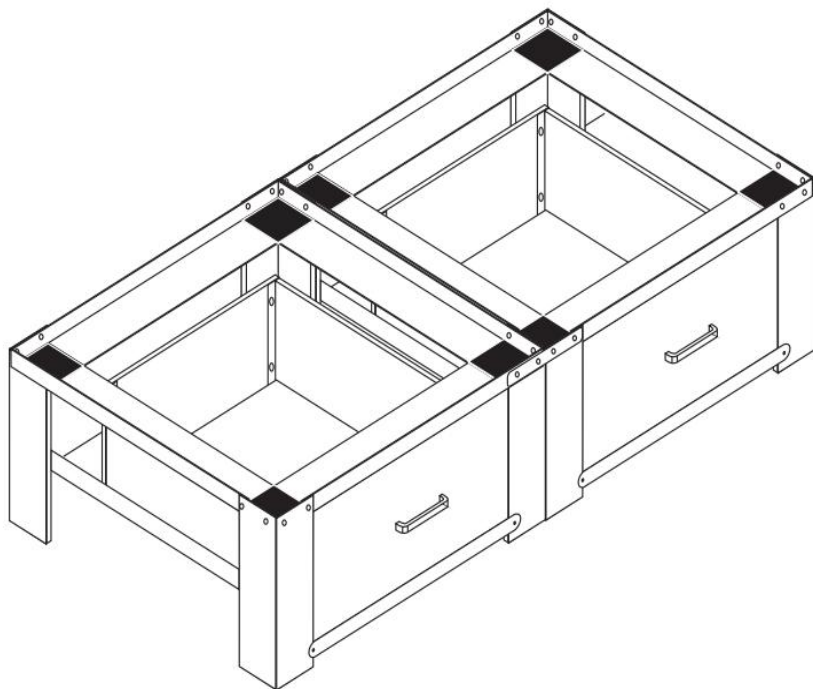

To jest oryginalna instrukcja obsługi. Przed użyciem prosimy o dokładne zapoznanie się z treścią instrukcji. Firma VEVOR zastrzega sobie prawo do jednoznacznej interpretacji niniejszej instrukcji obsługi. Wygląd produktu zależy od stanu, w jakim go otrzymali Państwo. Prosimy o wyrozumiałość, ale nie będziemy Państwa ponownie informować o aktualizacjach technologicznych lub oprogramowania naszego produktu.



Dziękujemy bardzo za wybór tego produktu. Należy zawsze obchodzić się z nim ostrożnie. Przed użyciem prosimy o przeczytanie całej instrukcji.







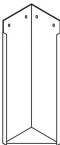

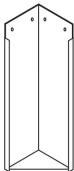

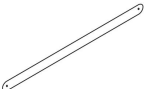
Informacje te pomogą Ci osiągnąć najlepsze możliwe rezultaty.

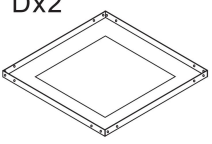

SPECIFICATION

Model	Rozmiar	Wysokość	Obciążenie postumentu	Obciążenie szuflady
S06-2	(610-510) × (520-420) mm	11,4 cala (290 mm)	330 (150 kg)	5 kg

PACKAGE LIST

NIE.	Nazwa	Zdjęcie	Numer
1	Noga kolumny A1	A1x2 	2
2	Noga kolumny A2	A2x2 	2
3	Noga kolumny A3	A3x2 	2
4	Noga kolumny A4	A4x2 	2

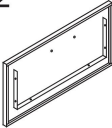
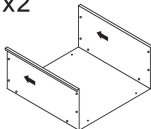
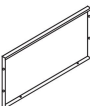
5	Wsparcie	Bx4 	4
6	Uchwyt	Yx2 	2
7	Płyta	Dx2 	2
8	Śruba M4*4	Nx4 	4
9	Pedał	E1x8  E2x8 	8
10	Tor kolumnowy	M1x2  M2x2 	2
11	Szyna szuflady	(7)x2  (8)x2 	2

12	Śruba M5*10	Lx80 	80
13	Płyta przednia szuflady	Fx2 	2
14	Dolna płyta szuflady	Jx2 	2
15	Tylna płyta szuflady	Kx2 	2
16	Złącze	Gx2 	2
17	Podręcznik	/	1

CAUTIONS

1. Nie należy pozwalać dzieciom wspinać się na urządzenie.
2. Trzymaj dzieci i zwierzęta z dala od siebie podczas montażu.
3. Produkt należy składać ściśle według instrukcji.
Nieprawidłowy montaż może być niebezpieczny.
4. Podczas montażu należy prawidłowo nosić okulary ochronne i rękawice robocze.

5. Nie należy podejmować próby montażu produktu, gdy jest się zmęczonym lub pod wpływem pod wpływem alkoholu, narkotyków lub leków.
6. Oddziel i policz wszystkie części i elementy sprzętowe.
7. Przygotuj następujące narzędzie: śrubokręt krzyżakowy.
8. Używając elektronarzędzi, należy zachować ostrożność i zwolnić, gdy wymagany.
9. Do montażu potrzebne są dwie osoby.
10. Stosuj wyłącznie zgodnie z przeznaczeniem. Nie siadaj ani nie stawaj na powyższych przedmiotach.

INSTRUCTIONS

Krok 1: Umieść D i A1 A2 A3 A4 tak, jak pokazano na rysunku, zwróć uwagę na położenie A1 A2 A3 A4 i połącz je z L

01

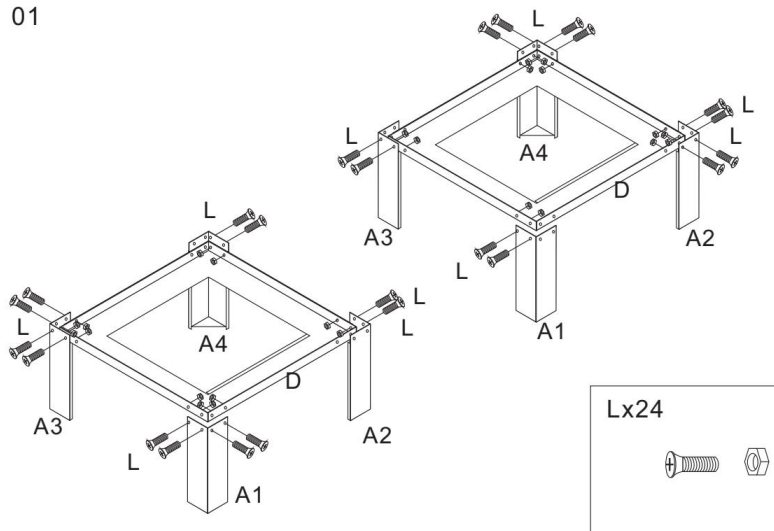

Krok 2: Podłącz M2 do A2 i A4. Podczas montażu M2, białe, okrągłe koło

na górze musi znajdować się blisko A2. Po podłączeniu M1 do A1 i A3, białe, okrągłe koło na górze musi znajdować się blisko A1 podczas montażu M1.

02

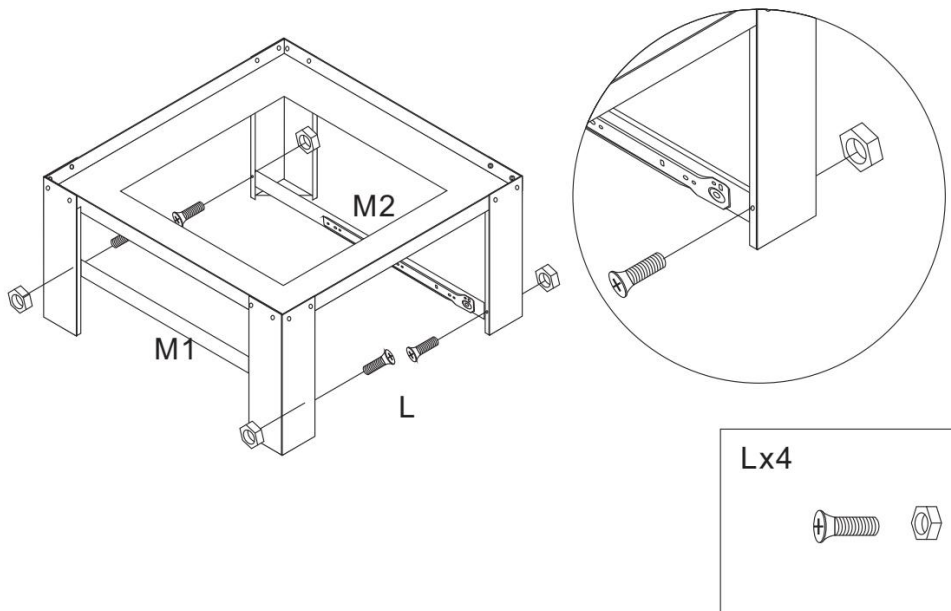

Krok 3: Zainstaluj B

03

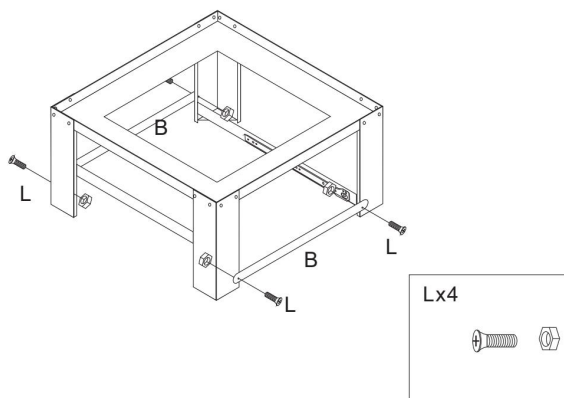

Krok 4: Powtórz kroki 2 i 3, połącz dwie bazy za pomocą G

04

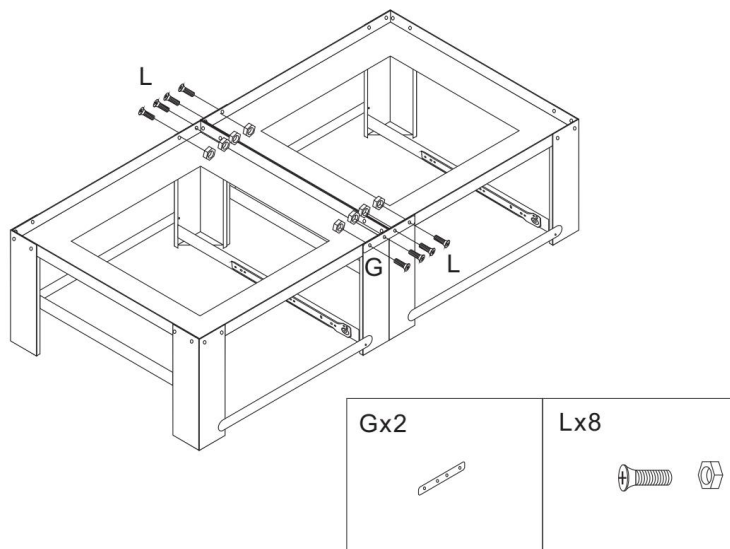

Krok 5: Otwórz J pod kątem 90° . Połącz F z J, zwracając uwagę na połączenie w miejscu, gdzie F otacza J. Połącz K z J, zwracając uwagę na płaską powierzchnię K skierowaną do wewnątrz. Zwróć uwagę na położenie otworu na śrubę podczas montażu dolnej szyny szuflady Y.

05

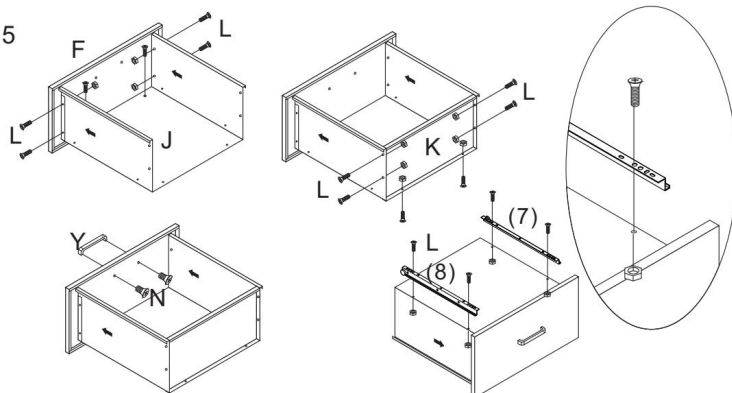

(7)x1 	Yx1 	Nx2 	Lx16
-----------	---------	---------	----------

Krok 6: Montaż szuflady

06

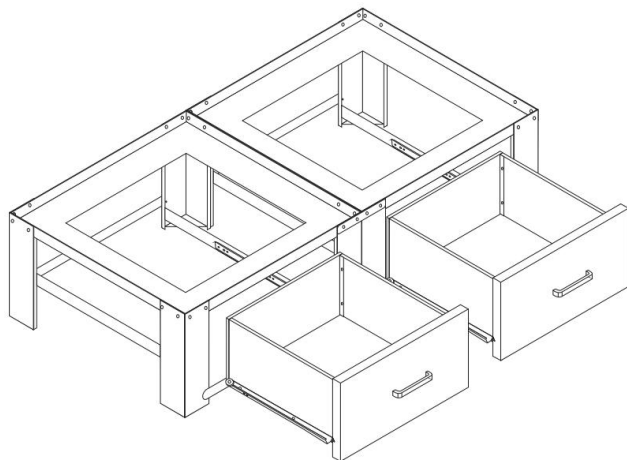

Krok 7: Zainstaluj E1 i E2, jak pokazano na rysunku

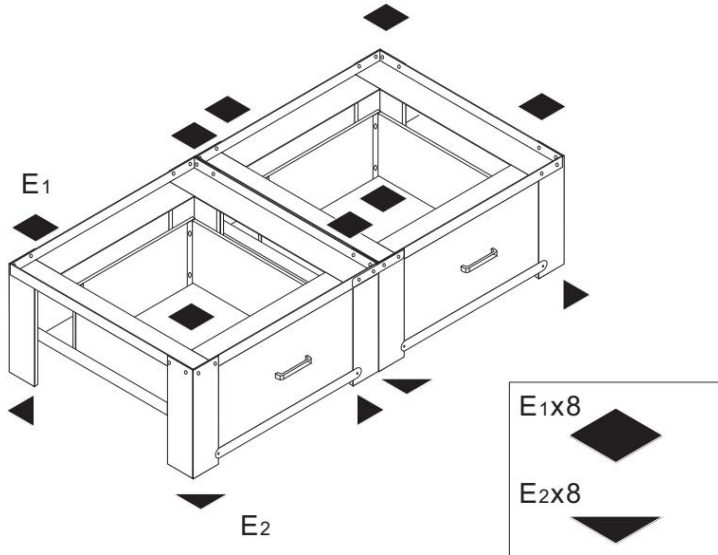

Producent: Shanghaimuxinmuyeyouxiangongsi

Adres: Shuangchenglu 803nong11hao1602A-1609shi, baoshanqu, szanghaj 200000 CN.

Importowane do AUS: SIHAO PTY LTD. 1 ROKEVA
STREETEASTWOOD
NSW 2122 Australia

Importowane do USA: Sanven Technology Ltd. Suite 250, 9166 Anaheim
Miejsce, Rancho Cucamonga, CA 91730

UK	REP
-----------	------------

YH CONSULTING LIMITED. C/O YH Consulting
Limited Office 147, Centurion House, London
Road, Staines-upon-Thames, Surrey, TW18 4AX

EC	REP
-----------	------------

E-CrossStu GmbH
Mainzer Landstr.69,
60329 Frankfurt am Main.



VEVOR

Affordable. Reliable. Home Improvement.

Wasmachine voetstuk

Model: S06-2

VEVOR

Affordable. Reliable. Home Improvement.

Laundry Pedestal

Model: S06-2

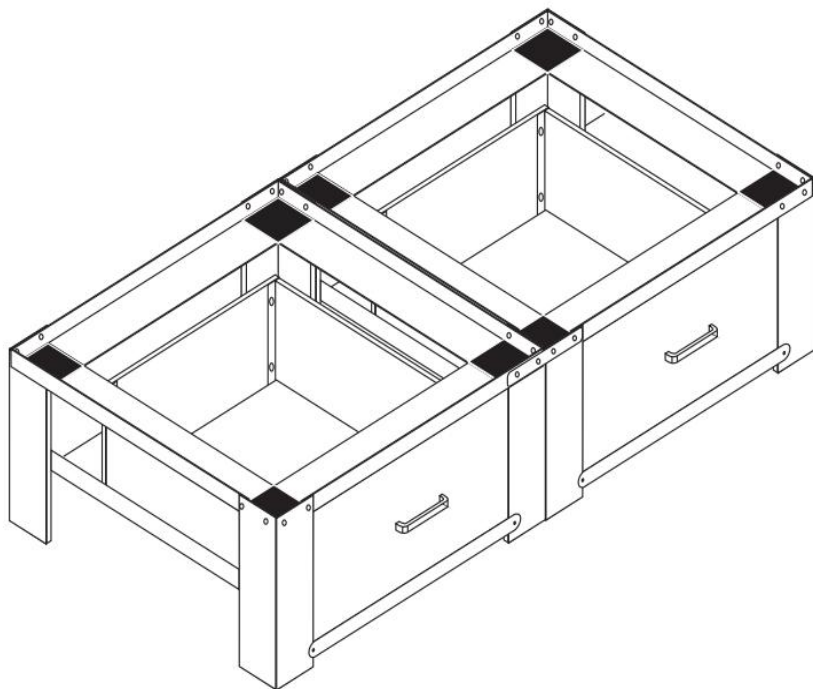

Dit is de originele handleiding. Lees alle instructies zorgvuldig door voordat u het product gebruikt. VEVOR behoudt zich het recht voor om de gebruiksaanwijzing duidelijk te interpreteren. Het uiterlijk van het product is afhankelijk van het product dat u hebt ontvangen. Neemt u het ons niet kwalijk dat we u niet meer op de hoogte stellen van eventuele technologische of software-updates voor ons product.



Hartelijk dank dat u voor dit product hebt gekozen. Ga er altijd voorzichtig mee om. Lees de gebruiksaanwijzing aandachtig door voordat u het







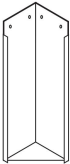

gebruikt. Met deze informatie kunt u de best mogelijke resultaten behalen.

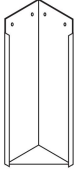
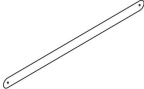

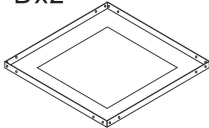

SPECIFICATION

Model	Maat	Hoogte	Lading van voetstuk	Lading van de lade
S06-2	(610-510) × (520-420) mm	11,4 inch (290 mm)	330 (150 kg)	5 kg

PACKAGE LIST

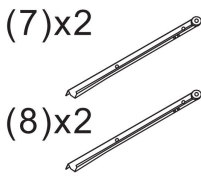
Nee.	Naam	Afbeelding	Numme r
1	Kolompoot A1	A ₁ x2 	2
2	Kolompoot A2	A ₂ x2 	2
3	Kolompoot A3	A ₃ x2 	2

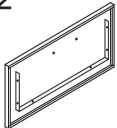
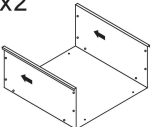
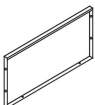
4	Kolompoot A4	A4x2 	2
5	Steun	Bx4 	4
6	Hendel	Yx2 	2
7	Bord	Dx2 	2
8	Schroef M4*4	Nx4 	4
9	Pedaal	E1x8  E2x8 	8
10	Kolomspoor	M1x2  M2x2 	2

11	Laderail	(7)x2  (8)x2	2
12	M5*10 schroef	Lx80 	80
13	Lade frontplaat	Fx2 	2
14	Bodemplaat van de lade	Jx2 	2
15	Achterplaat van de lade	Kx2 	2
16	Verbindingsstuk	Gx2 	2
17	Handmatig	/	1

CAUTIOUS

1. Laat kinderen niet op het apparaat klimmen.
2. Houd kinderen en huisdieren uit de buurt tijdens de montage
3. Monteer het product strikt volgens de instructies.
Onjuiste montage kan gevaarlijk zijn.
4. Draag tijdens de montage een veiligheidsbril en werkhandschoenen.
5. Probeer het product niet te monteren als u zich moe voelt of onder invloed bent.
invloed van alcohol, drugs of medicijnen.
6. Scheid alle onderdelen en hardware en tel ze.
7. Bereid het volgende gereedschap voor: kruiskopschroevendraaier.
8. Als u elektrisch gereedschap gebruikt, zorg er dan voor dat u vaart mindert en stopt wanneer u nodig.
9. Voor de montage zijn twee personen nodig.
10. Volg alleen het beoogde gebruik. Ga niet op de bovenstaande plaatsen zitten of staan.

INSTRUCTIONS

Stap 1: Plaats D en A1 A2 A3 A4 zoals aangegeven in de afbeelding, let op de positie van A1 A2 A3 A4 en verbind ze met L

01

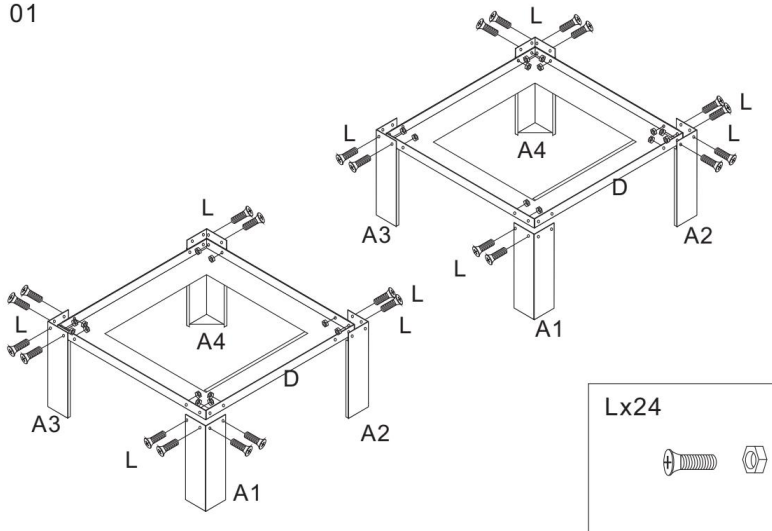

Stap 2: Verbind M2 met A2 en A4. Bij het installeren van M2 moet het witte ronde wielje bovenaan dicht bij A2 zitten. Wanneer M1 is verbonden met A1 en A3, moet het witte ronde wielje bovenaan dicht bij A1 zitten bij het installeren van M1.

02

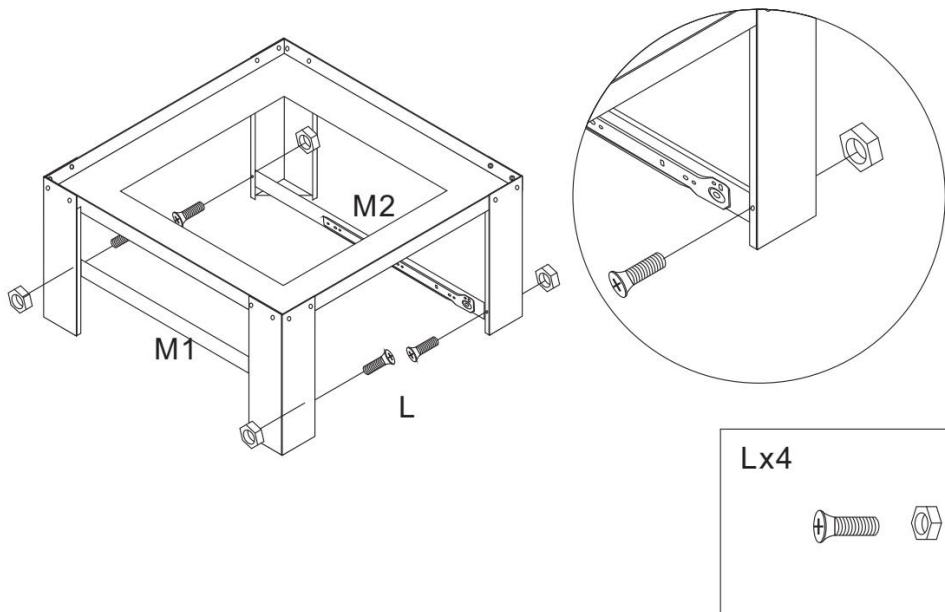

Stap 3: B installeren

03

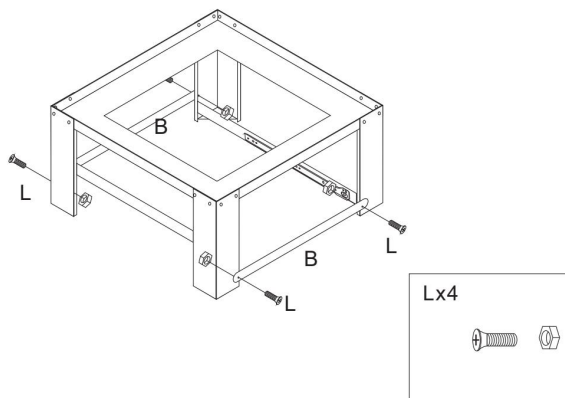

Stap 4: Herhaal stap 2 en 3, verbind de twee bases met G

04

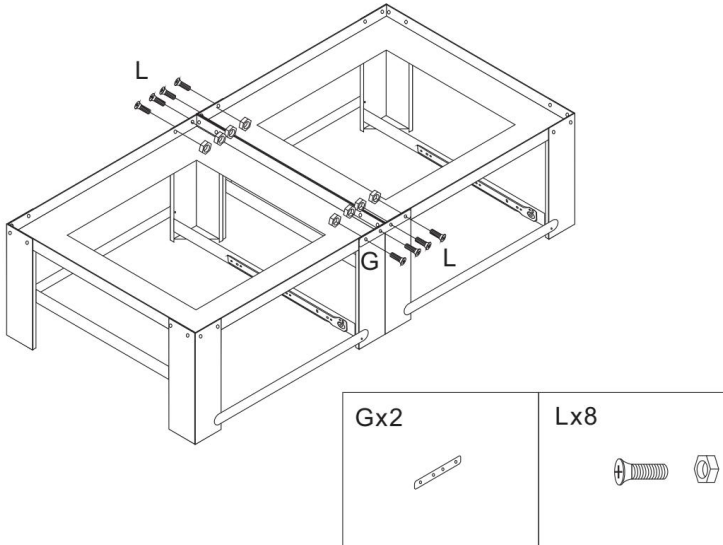

Stap 5: Open J tot 90°. Verbind F met J, let op de verbinding waar F J omringt. Verbind K met J, let op dat het vlakke oppervlak van K naar binnen wijst. Let op de positie van de schroefgaten bij het installeren van de onderste rail van de Y-lade.

05

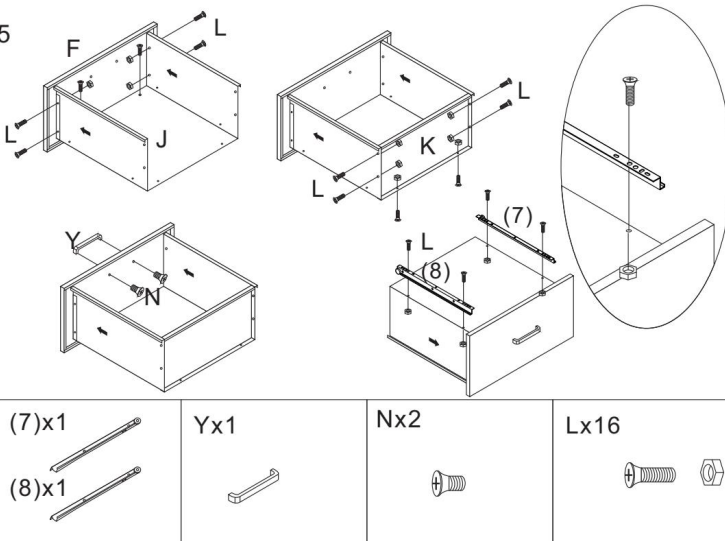

Stap 6: De lade installeren

06

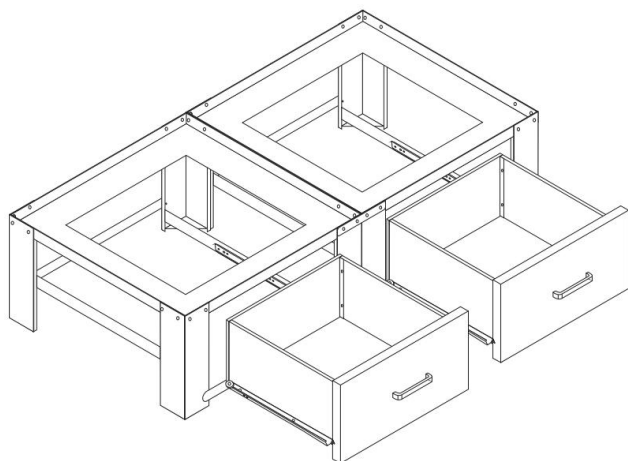

Stap 7: Installeer E1 en E2 zoals weergegeven in de afbeelding

07

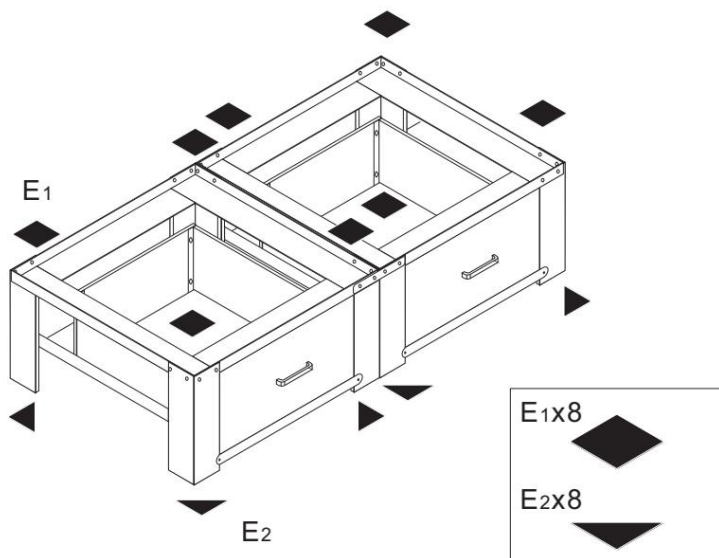

Fabrikant: Shanghaimuxinmuyeyouxiangongsi

Adres: Shuangchenglu 803nong11hao1602A-1609shi, baoshanqu, shanghai 200000 CN.

Geïmporteerd naar AUS: SIHAO PTY LTD. 1 ROKEVA

STREETEASTWOOD

NSW 2122 Australië

Geïmporteerd naar de VS: Sanven Technology Ltd. Suite 250, 9166

Anaheim

Plaats, Rancho Cucamonga, CA 91730

UK	REP
-----------	------------

YH CONSULTING LIMITED. C/O YH Consulting
Limited Office 147, Centurion House, London
Road, Staines-upon-Thames, Surrey, TW18 4AX

EC	REP
-----------	------------

E-CrossStu GmbH
Mainzer Landstr.69,
60329 Frankfurt am Main.



VEVOR

Affordable. Reliable. Home Improvement.

Tvättstuga piedestal

Modell: S06-2

VEVOR

Affordable. Reliable. Home Improvement.

Laundry Pedestal

Modell: S06-2

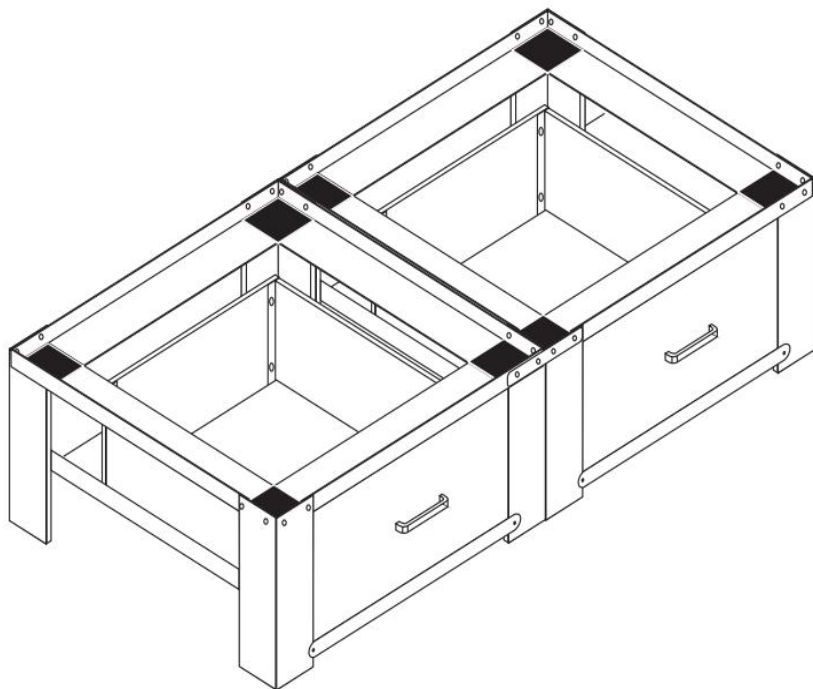

Detta är originalinstruktionerna, vänligen läs alla instruktioner noggrant innan du använder produkten. VEVOR förbehåller sig en tydlig tolkning av vår användarmanual. Produktens utseende ska vara beroende av den produkt du mottagit. Vi ber om ursäkt för att vi inte kommer att informera dig igen om det finns några teknik- eller programuppdateringar för vår produkt.



Tack så mycket för att du valde den här produkten, den bör alltid hanteras varsamt. Läs alla instruktioner innan du använder den. Informationen









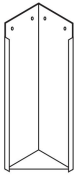

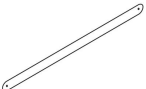
kommer att hjälpa dig att uppnå bästa möjliga resultat.

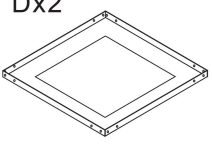

SPECIFICATION

Modell	Storlek	Höjd	Last av pedestal	Last av låda
S06-2	(610–510) × (520–420) mm	11,4 tum (290 mm)	330 (150 kg)	5 kg

PACKAGE LIST

Inga.	Namn	Bild	Antal
1	Kolumnben A1	A1x2 	2
2	Kolumnben A2	A2x2 	2
3	Kolumnben A3	A3x2 	2
4	Kolumnben A4	A4x2 	2

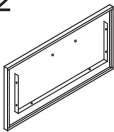
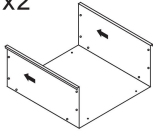
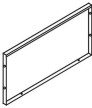
5	Stöd	Bx4 	4
6	Hantera	Yx2 	2
7	Tallrik	Dx2 	2
8	Skruv M4*4	Nx4 	4
9	Trampa	E1x8  E2x8 	8
10	Kolumnspår	M1x2  M2x2 	2
11	Lådskena	(7)x2  (8)x2 	2

12	M5*10 skruv	Lx80 	80
13	Lådfrontplatta	Fx2 	2
14	Lådans bottenplatta	Jx2 	2
15	Lådans bakre plåt	Kx2 	2
16	Kontakt	Gx2 	2
17	Manuell	/	1

CAUTIOUS

1. Låt inte barn klättra på enheten.
2. Håll barn och husdjur borta under monteringen
3. Montera produkten noggrant enligt instruktionerna.
Felaktig montering kan vara farlig.
4. Använd skyddsglasögon och arbetshandskar på lämpligt sätt under monteringen.

5. Försök inte montera produkten när du känner dig trött eller under belastning.
påverkan av alkohol, droger eller medicinering.
6. Separera och räkna alla delar och hårdvara.
7. Förbered följande verktyg: Stjärnskruvmejsel.
8. Om du använder elverktyg, var noga med att sakta ner och stanna när behövs.
9. Monteringen är två personer.
10. Följ endast avsedd användning. Sitt eller stå inte på ovanstående.

INSTRUCTIONS

Steg 1: Placera D och A1 A2 A3 A4 som visas i figuren, var uppmärksam på positionen för A1 A2 A3 A4 och anslut dem med L

01

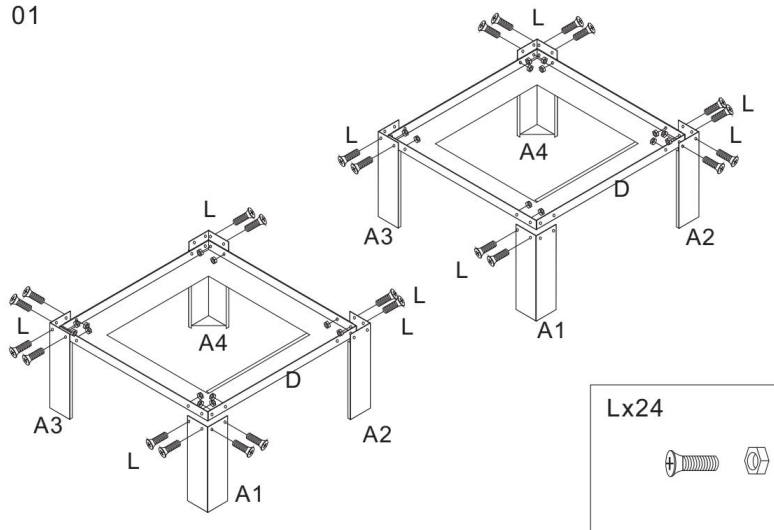

Steg 2: Anslut M2 till A2 och A4. När du installerar M2 måste det vita runda hjulet ovanpå vara nära A2. När M1 är anslutet till A1 och A3 måste det vita

runda hjulet ovanpå vara nära A1 när du installerar M1

02

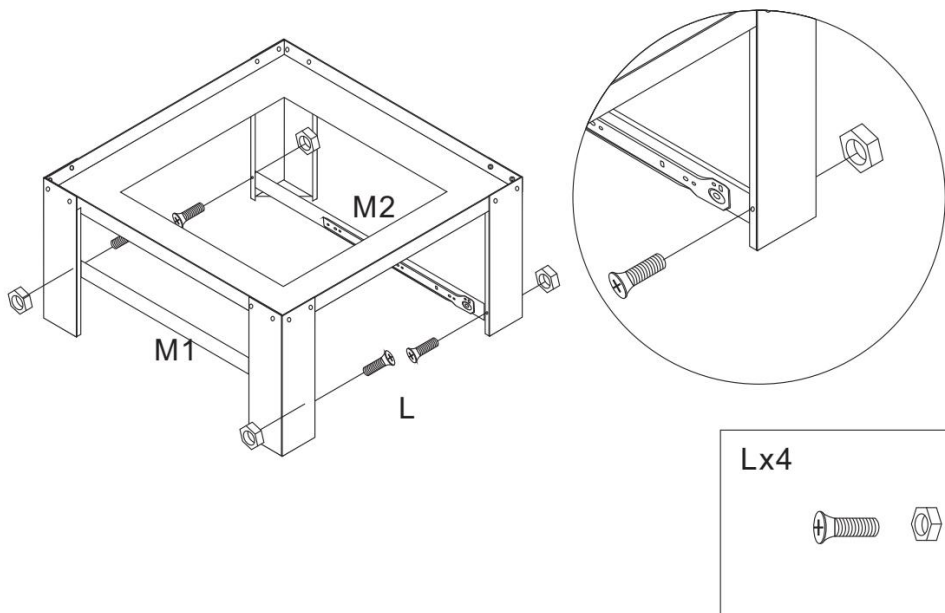

Steg 3: Installera B

03

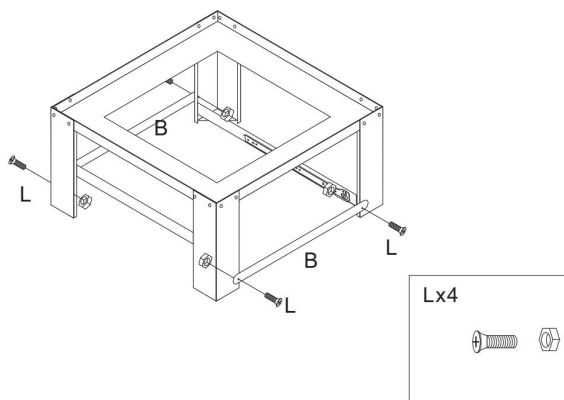

Steg 4: Upprepa steg 2 och 3, anslut de två baserna med G

04

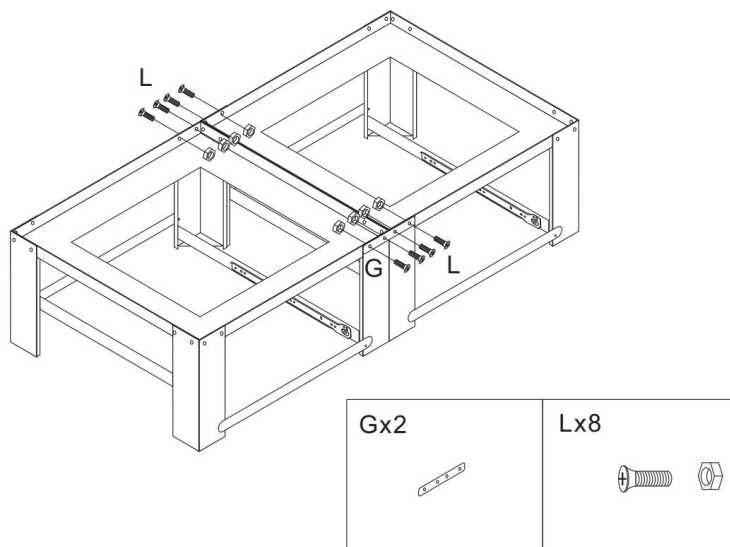

Steg 5: Öppna J till 90°. Anslut F till J, var uppmärksam på anslutningen där F omger J. Anslut K till J, var uppmärksam på att den plana ytan på K är vänd inåt. Var uppmärksam på skruvhålens position när du monterar Y-lådans bottenstena.

05

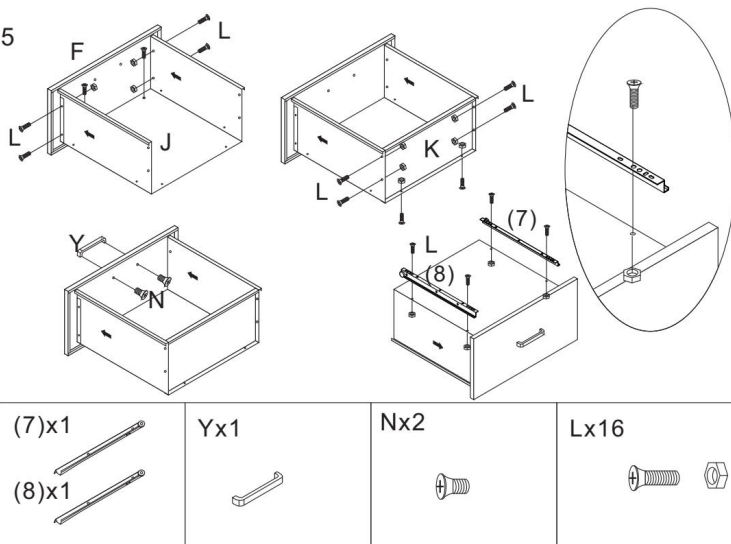

Steg 6: Montera lådan

06

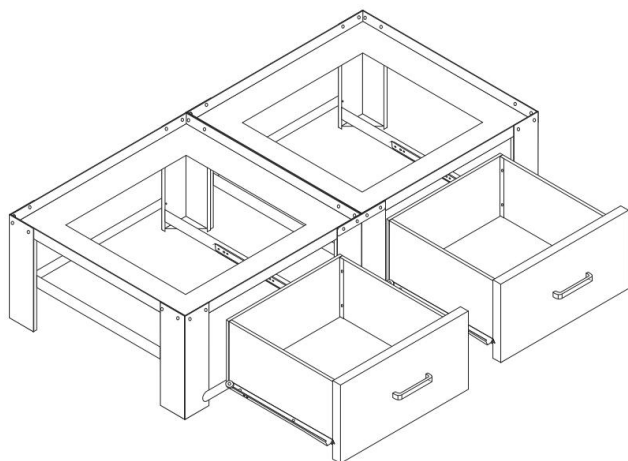

Steg 7: Montera E1 och E2 enligt bilden

07

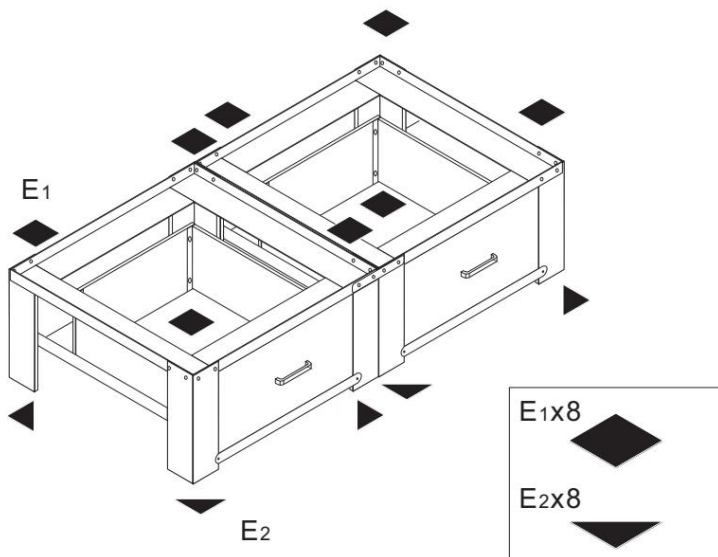

Tillverkare: Shanghaimuxinmuyeyouxiangongsi

Adress: Shuangchenglu 803nong11hao1602A-1609shi, baoshanqu, Shanghai 200 000 kanadensiska republiken.

Importerad till Australien: SIHAO PTY LTD. 1 ROKEVA

STREETEASTWOOD

NSW 2122 Australien

Importerad till USA: Sanven Technology Ltd. Suite 250, 9166 Anaheim Plats, Rancho Cucamonga, Kalifornien 91730

UK	REP
-----------	------------

YH CONSULTING LIMITED. C/O YH Consulting Limited Office 147, Centurion House, London Road, Staines-upon-Thames, Surrey, TW18 4AX

EC	REP
-----------	------------

E-CrossStu GmbH
Mainzer Landstr.69,
60329 Frankfurt am Main.

