

VEVOR

Affordable. Reliable. Home Improvement.

STEERING WHEEL STAND

MODEL:QY-GL08

VEVOR

Affordable. Reliable. Home Improvement.

STEERING WHEEL STAND

MODEL:QY-GL08

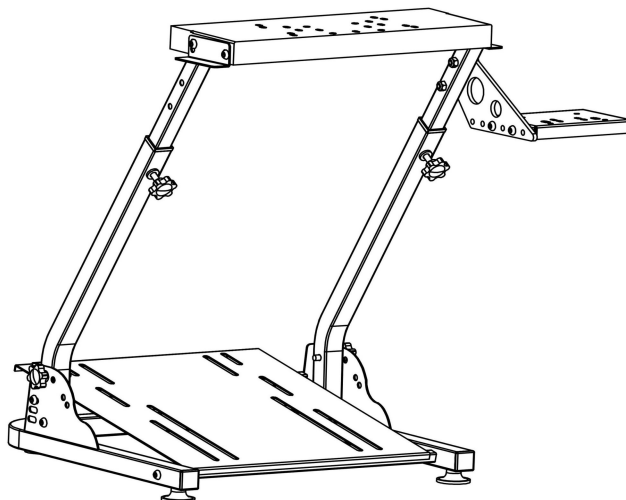













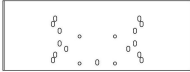

This is the original instruction, please read all manual instructions carefully before operating. VEVOR reserves a clear interpretation of our user manual. The appearance of the product shall be subject to the product you received. Please forgive us that we won't inform you again if there are any technology or software updates on our product.





Warning-To reduce the risk of injury, user must read instructions manual carefully.

Part List

1		Rack	1
---	---	------	---

2		Left and right support rods	2
3		Left and Right Armrests	2
4		Wheel Plate	1
5		Shifter Plate	1
6		Shifter Mounting Arm	1
7		Knob M8*20	2
8		Knob M8*40	2
9		Feet	4
10		Screw M6*16	12
11		Screw M8*40	4
12		Screw M8*16	4
13		Nut M6	2
14		Nut M8	8
15		Washer 8	8
16		Hex key 5	1

17		Hex key 4	1
18		Wench 9-13	1
19		Binding Strap	6

Product Installation

STEP 1: Use 4 rubber screws to fix the bottom of the bracket to adjust the balance of the bracket.

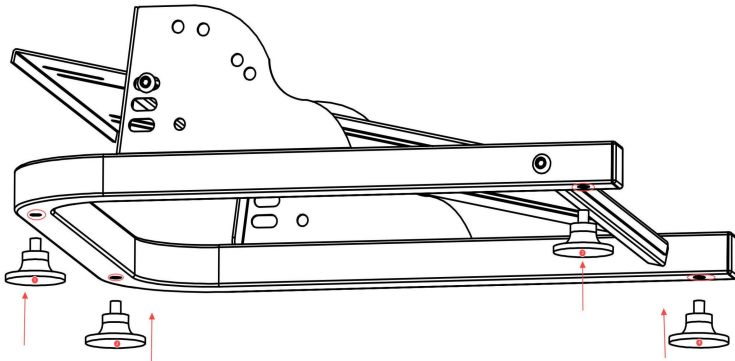

STEP 2: Two Knob M8*40 and two M8*40 screws are used to fix the bracket support bar respectively.

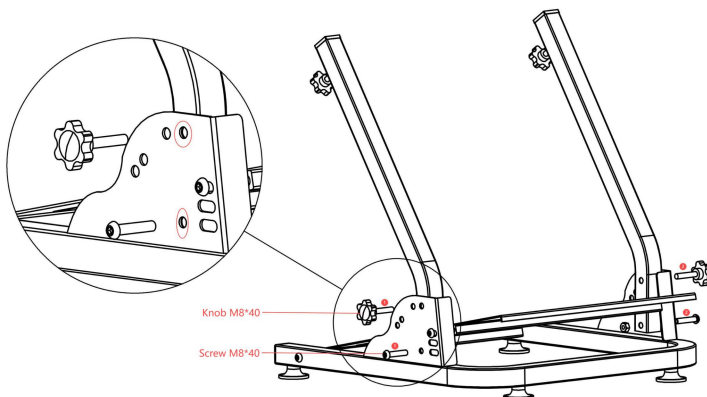

STEP 3: Insert the telescopic pole and fix it with knob M8*20 screws, the telescopic pole can be adjusted in height.

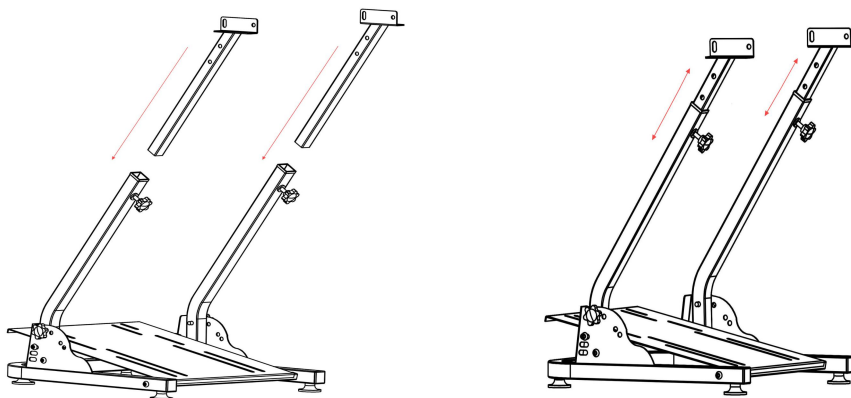

STEP 4: Put it into the steering wheel panel and fix it with 4 M8*16 screws and M8 nuts. The angle of the steering wheel panel can be fine-tuned.

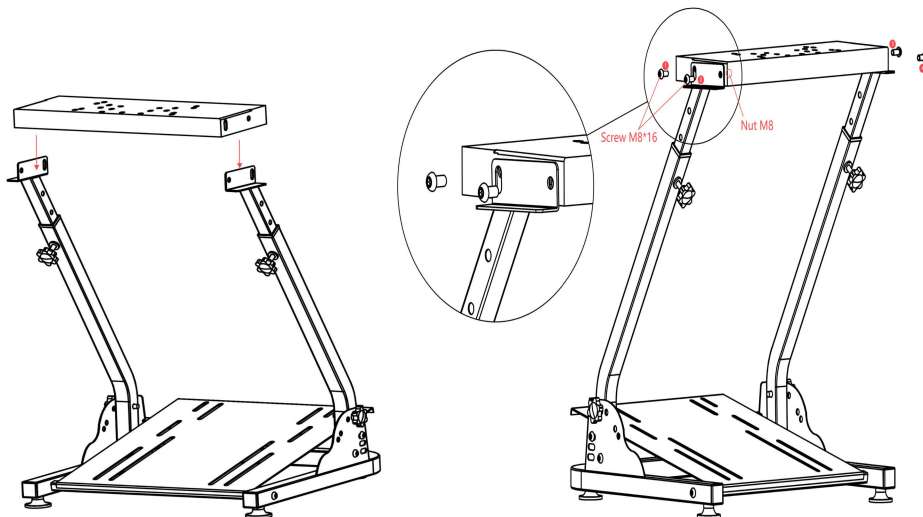

STEP 5: Install the partner tray connection plate, fix it with 2 M8*40 screws and nuts.

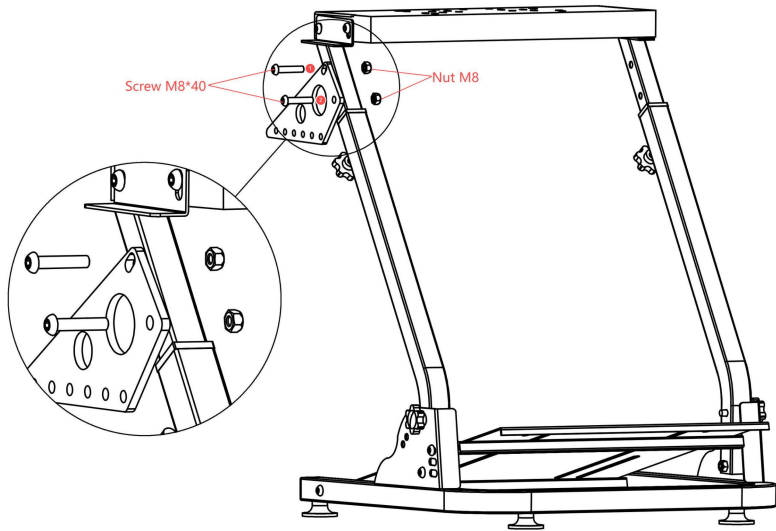

STEP 6: Install the partner disk panel and fix it with 2 M6*16 screws and nuts.

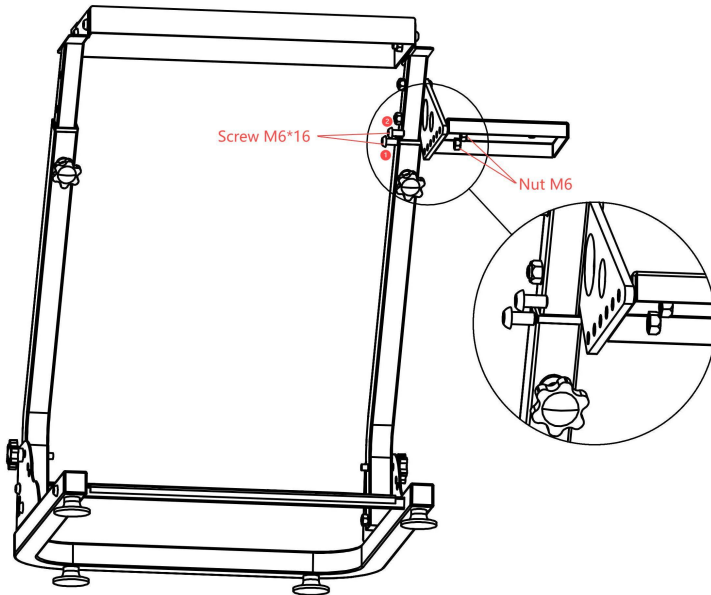

Installation completed

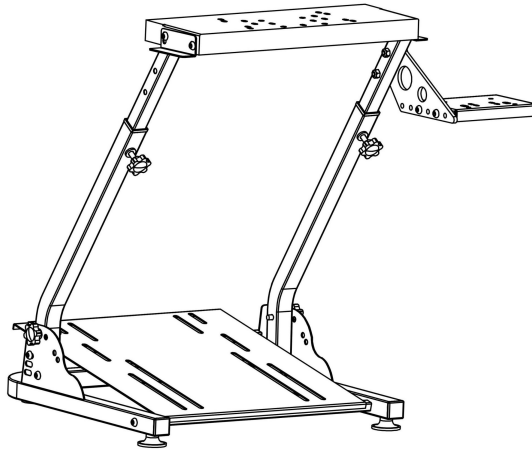

Folding steps of bracket

1. Unscrew the 2 knob M8*40 screws on the left and right below the bracket.
2. Fold the stand and store it against the wall.

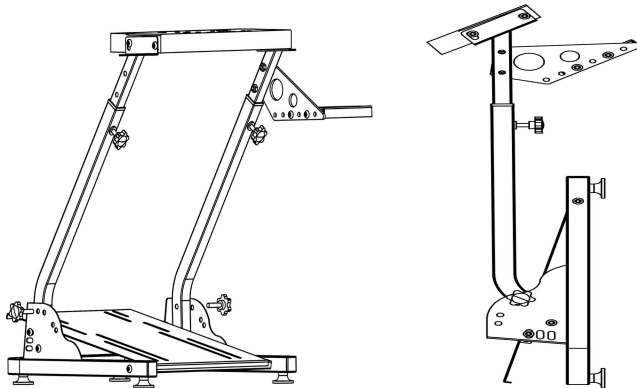

Manufacturer: Shanghaimuxinmuyeyouxiangongsi

Address: Shuangchenglu 803nong11hao1602A-1609shi, baoshanqu, shanghai 200000 CN.

Imported to AUS: SIHAO PTY LTD. 1 ROKEVA STREET EASTWOOD

NSW 2122 Australia

Imported to USA: Sanven Technology Ltd. Suite 250, 9166 Anaheim Place, Rancho Cucamonga, CA 91730

UK	REP
-----------	------------

YH CONSULTING LIMITED. C/O YH Consulting Limited Office 147, Centurion House, London Road, Staines-upon-Thames, Surrey, TW18 4AX

EC	REP
-----------	------------

E-CrossStu GmbH
Mainzer Landstr.69,
60329 Frankfurt am Main.



VEVOR

Affordable. Reliable. Home Improvement.

SUPPORT DE VOLANT

MODÈLE : QY-GL08

VEVOR

Affordable. Reliable. Home Improvement.

STEERING WHEEL STAND

MODÈLE : QY-GL08

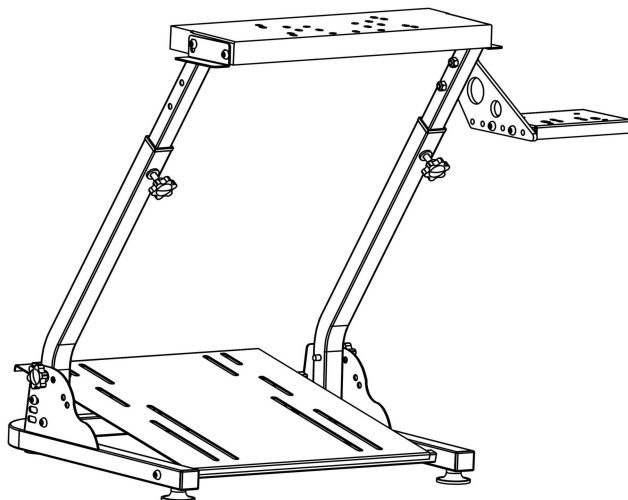











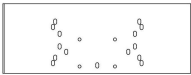

Ceci est le mode d'emploi d'origine. Veuillez lire attentivement l'intégralité du manuel avant utilisation. VEVOR se réserve le droit d'interpréter clairement ce manuel d'utilisation. L'apparence du produit dépend du produit que vous avez reçu. Veuillez nous excuser pour les éventuelles mises à jour technologiques ou logicielles.







Avertissement - Pour réduire le risque de blessure, l'utilisateur doit lire attentivement le manuel d'instructions.

Liste des pièces

1		Étagère	1
---	---	---------	---

2		Gauche et droite tiges de support	2
3		Gauche et droite Accoudoirs	2
4		plaque de roue	1
5		plaque de changement de vitesse	1
6		Montage du levier de vitesses Bras	1
7		Bouton M8* 20	2
8		Bouton M8* 40	2
9		Pieds	4
10		Vis M6*16	12
11		Vis M8*40	4
12		Vis M8*16	4
13		Écrou M6	2
14		Écrou M 8	8
15		Rondelle 8	8

16		Clé hexagonale 5	1
17		Clé hexagonale 4	1
18		Fille 9-13	1
19		Sangle de fixation	6

Installation du produit

ÉTAPE 1 : Utilisez 4 vis en caoutchouc pour fixer le bas du support pour ajuster l'équilibre du support.

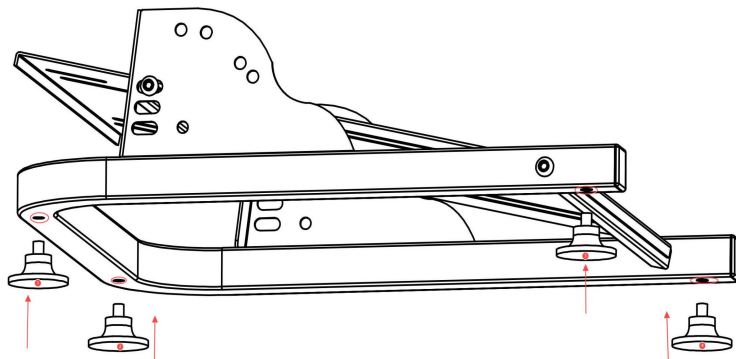

ÉTAPE 2 : Deux boutons M8*40 et deux vis M8*40 sont utilisés pour fixer respectivement la barre de support du support.

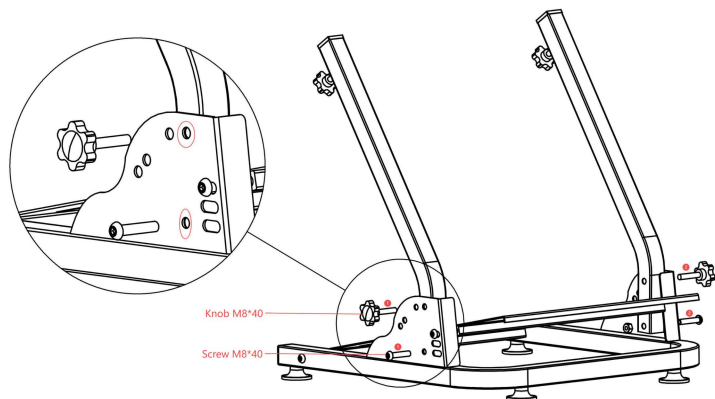

ÉTAPE 3 : Insérez le poteau télescopique et fixez-le avec des vis à bouton M8*20, le poteau télescopique peut être réglé en hauteur.

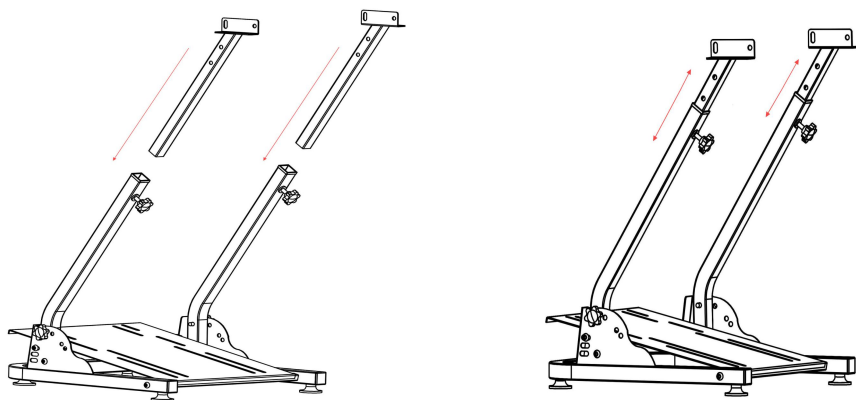

ÉTAPE 4 : Insérez-le dans le panneau du volant et fixez-le avec 4 vis M8*16 et écrous M8. L'angle du panneau du volant peut être ajusté avec précision.

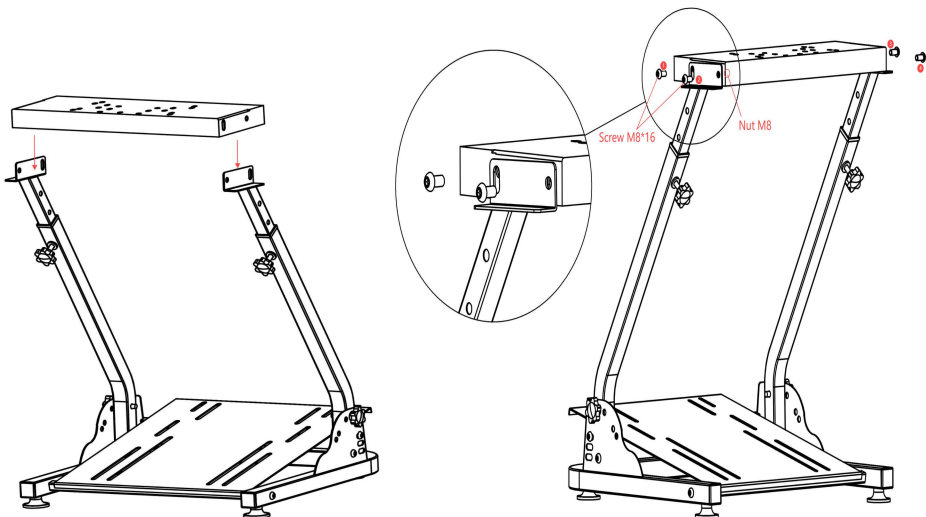

ÉTAPE 5 : Installez la plaque de connexion du plateau partenaire, fixez-la avec 2 vis et écrous M8*40.

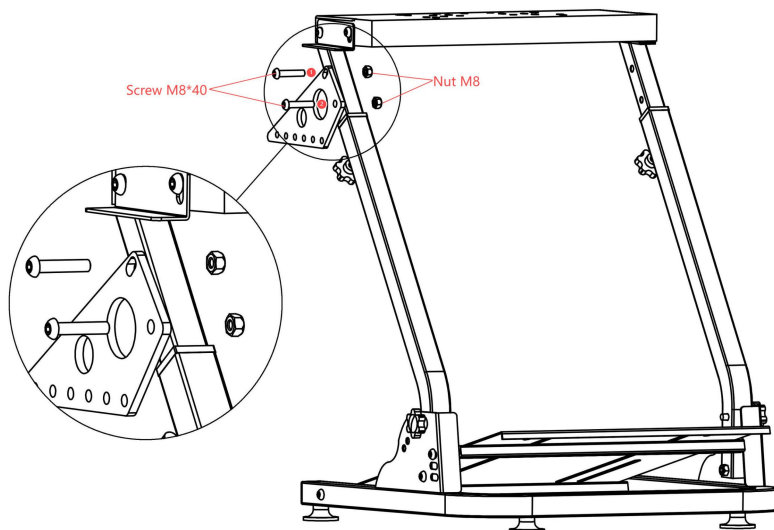

ÉTAPE 6 : Installez le panneau du disque partenaire et fixez-le avec 2 vis et écrous M6*16.

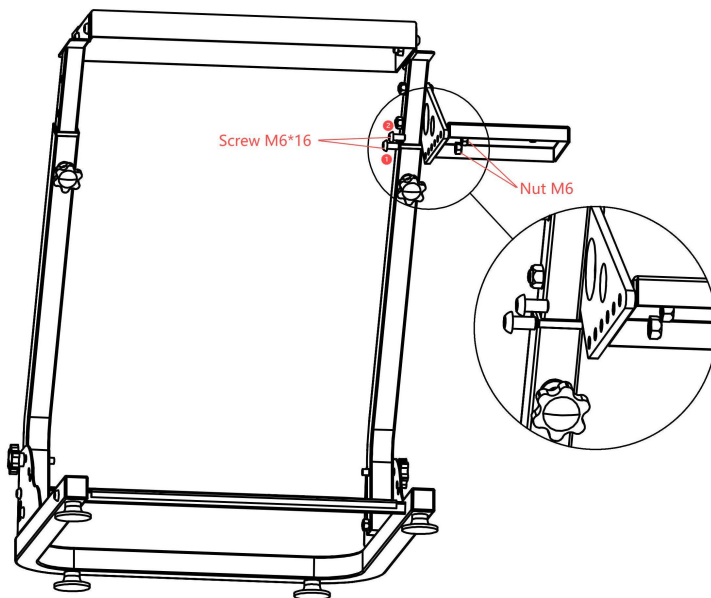

Installation terminée

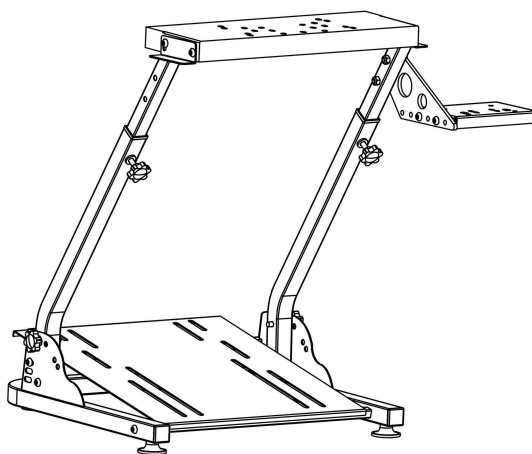

Marches pliantes du support

1. Dévissez les 2 vis à bouton M8*40 à gauche et à droite sous le support .
2. Pliez le support et rangez-le contre le mur .

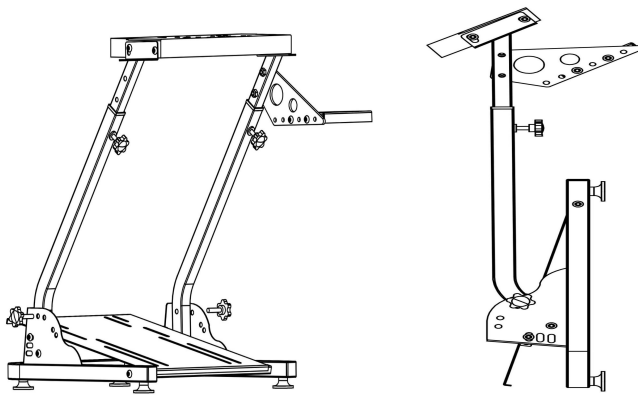

Fabricant : Shanghai muxinmuyeyouxiangongsi

Adresse : Shuangchenglu 803nong11hao1602A-1609shi, baoshanqu, Shanghai 200 000 CN.

Importé en Australie : SIHAO PTY LTD. 1 ROKEVA STREET, ASTWOOD

NSW 2122 Australie

Importé aux États-Unis : Sanven Technology Ltd. Suite 250, 9166
Anaheim

Lieu, Rancho Cucamonga, CA 91730

UK	REP
-----------	------------

YH CONSULTING LIMITED. C/O YH Consulting
Limited Office 147, Centurion House, London
Road, Staines-upon-Thames, Surrey, TW18 4AX

EC	REP
-----------	------------

E-CrossStu GmbH
Mainzer Landstr.69,
60329 Frankfurt am Main.



VEVOR

Affordable. Reliable. Home Improvement.

LENKRADSTÄNDER

MODELL: QY-GL08

VEVOR

Affordable. Reliable. Home Improvement.

STEERING WHEEL STAND

MODELL: QY-GL08

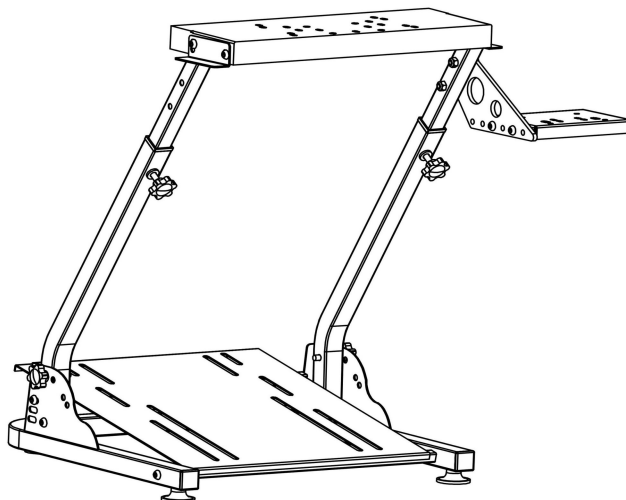









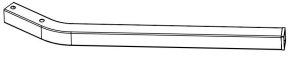

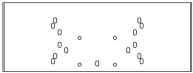
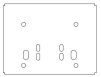





Dies ist die Originalanleitung. Bitte lesen Sie alle Anweisungen sorgfältig durch, bevor Sie das Gerät in Betrieb nehmen. VEVOR behält sich das Recht vor, die Bedienungsanleitung klar und deutlich zu interpretieren. Das Aussehen des Produkts hängt vom gelieferten Produkt ab. Bitte haben Sie Verständnis dafür, dass wir Sie nicht erneut über Technologie- oder Software-Updates informieren.



Warnung: Um das Verletzungsrisiko zu verringern, muss der Benutzer die Bedienungsanleitung sorgfältig lesen.

Teilleiste

1		Gestell	1
2		Links und rechts Stützstangen	2
3		Links und Rechts Armlehnen	2
4		Radplatte	1
5		Schaltplatte	1
6		Schalthebelmontage Arm	1
7		Knopf M8* 20	2
8		Knopf M8* 40	2
9		Füße	4
10		Schraube M6*16	12
11		Schraube M8*40	4
12		Schraube M8*16	4
13		Mutter M6	2
14		Mutter M 8	8

15		Unterlegscheibe 8	8
16		Inbusschlüssel 5	1
17		Inbusschlüssel 4	1
18		Mädchen 9-13	1
19		Bindegurt	6

Produktinstallation

SCHRITT 1: Befestigen Sie die Unterseite der Halterung mit 4 Gummischrauben um die Balance der Halterung anzupassen.

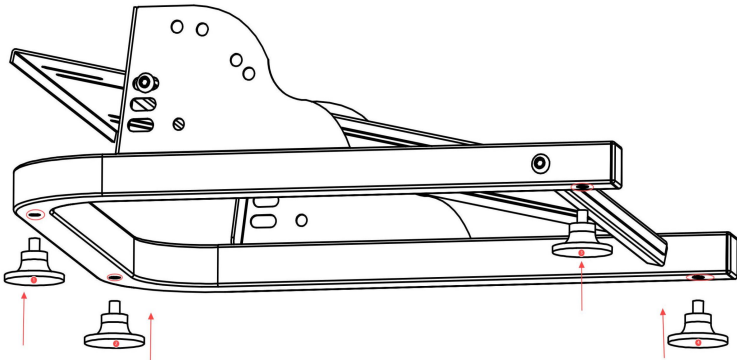

SCHRITT 2: Zwei Knöpfe M8*40 und zwei Schrauben M8*40 werden verwendet, um die Halterungsstützstange zu befestigen.

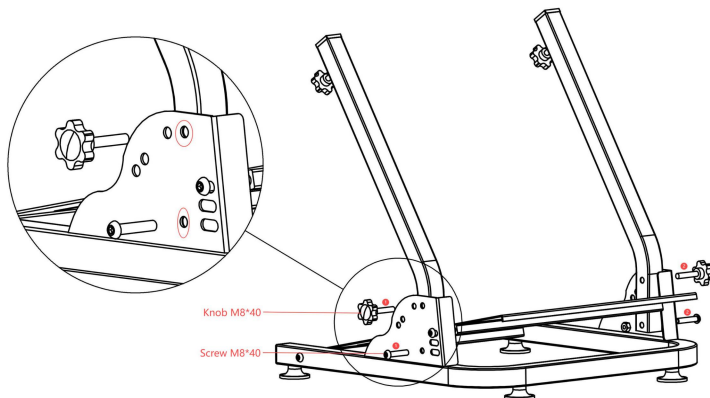

SCHRITT 3: Setzen Sie die Teleskopstange ein und befestigen Sie sie mit den Schrauben des Knopfes M8*20. Die Teleskopstange kann in der Höhe verstellt werden.

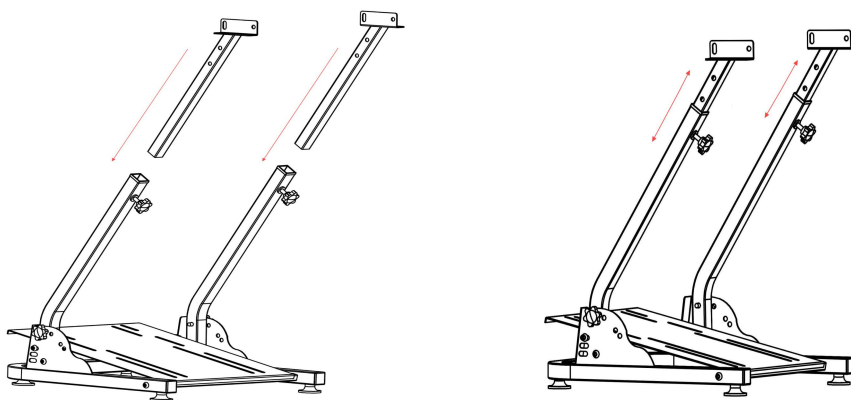

SCHRITT 4: Setzen Sie es in die Lenkradverkleidung ein und befestigen Sie es mit 4 M8*16-Schrauben und M8-Muttern. Der Winkel der Lenkradverkleidung kann feinjustiert werden.

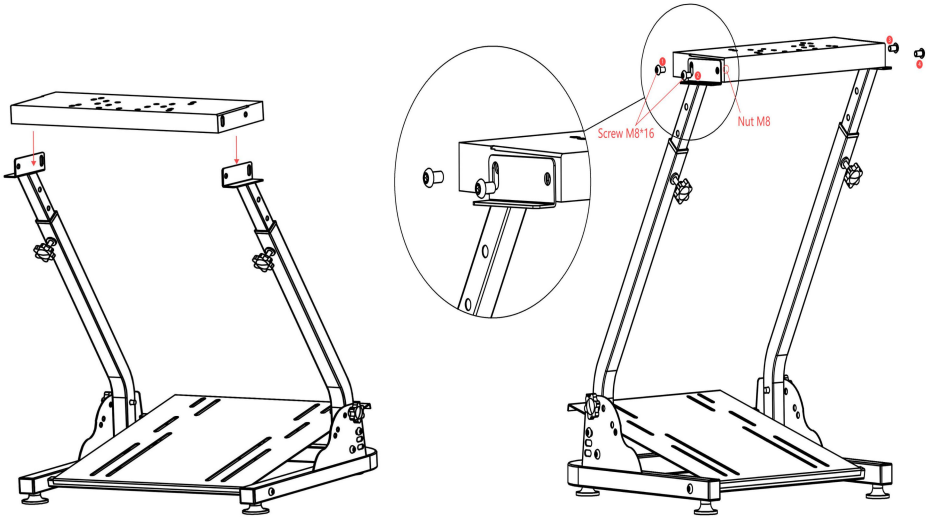

SCHRITT 5: Installieren Sie die Partnerfach-Verbindungsplatte und befestigen Sie sie mit 2 M8*40-Schrauben und Muttern.

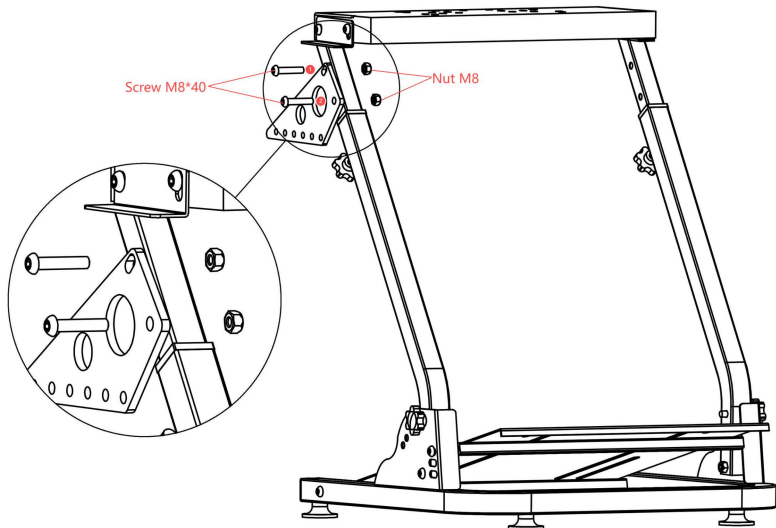

SCHRITT 6: Installieren Sie die Partner-Disk-Platte und befestigen Sie sie mit 2 M6*16-Schrauben und Muttern.

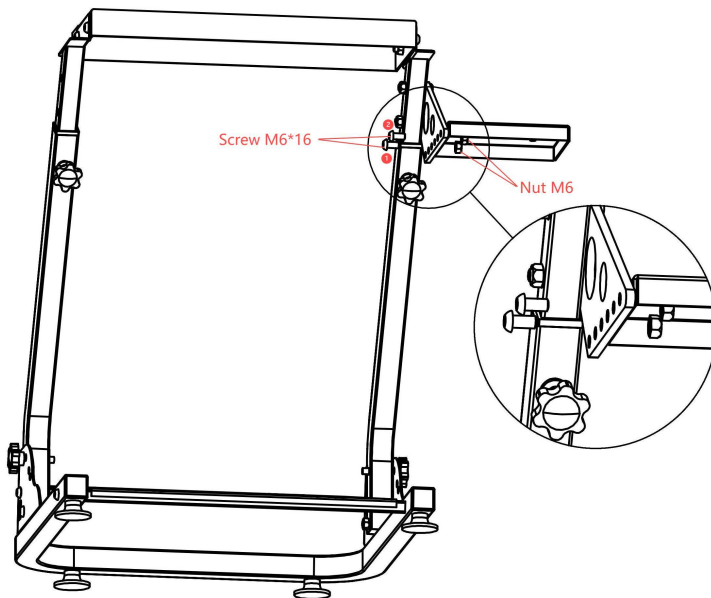

Installation abgeschlossen

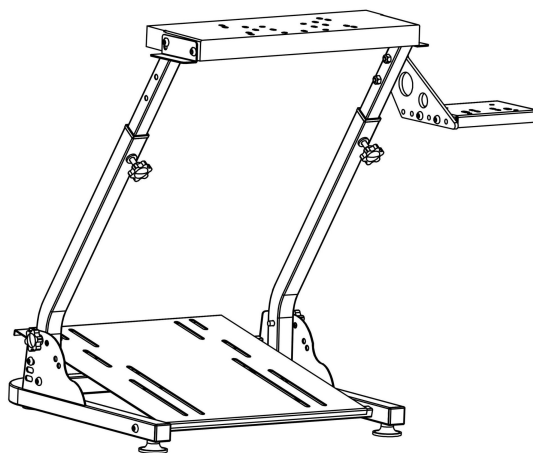

Klappstufen der Halterung

1. Die beiden M8*40-Knopfschrauben links und rechts unterhalb der Halterung lösen .

2. Klappen Sie den Ständer zusammen und verstauen Sie ihn an der Wand .

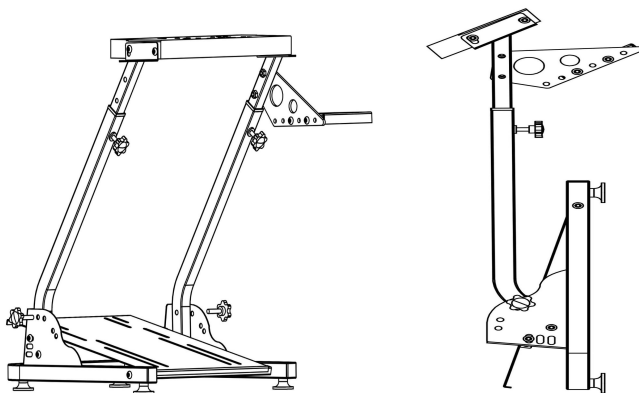

Hersteller: Shanghai muxin muyeyouxiangongsi

Adresse: Shuangchenglu 803nong11hao1602A-1609shi, baoshanqu, Shanghai 200.000 CN.

Importiert nach AUS: SIHAO PTY LTD. 1 ROKEVA STREET EASTWOOD

NSW 2122 Australien

Importiert in die USA: Sanven Technology Ltd. Suite 250, 9166 Anaheim Place, Rancho Cucamonga, CA 91730

UK	REP
-----------	------------

YH CONSULTING LIMITED. C/O YH Consulting Limited Office 147, Centurion House, London Road, Staines-upon-Thames, Surrey, TW18 4AX

EC	REP
-----------	------------

E-CrossStu GmbH
Mainzer Landstr.69,
60329 Frankfurt am Main.



VEVOR

Affordable. Reliable. Home Improvement.

SUPPORTO PER VOLANTE

MODELLO: QY-GL08

VEVOR

Affordable. Reliable. Home Improvement.

STEERING WHEEL STAND

MODELLO: QY-GL08

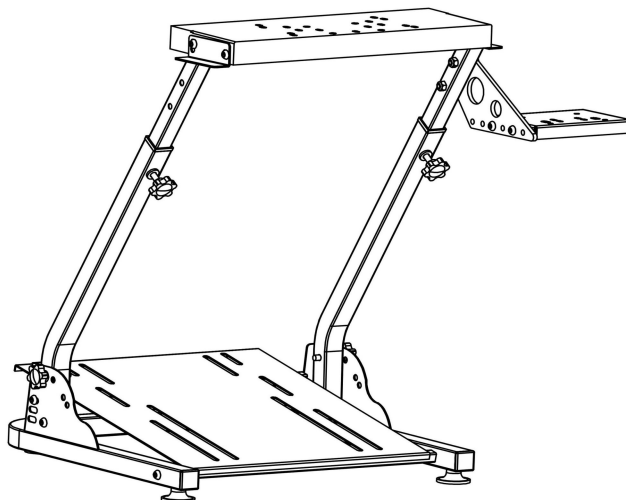











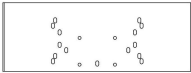







Queste sono le istruzioni originali, si prega di leggere attentamente tutte le istruzioni del manuale prima di utilizzare il prodotto. VEVOR si riserva la piena interpretazione del manuale utente. L'aspetto del prodotto dipenderà dal prodotto ricevuto. Vi preghiamo di non informarvi ulteriormente in caso di aggiornamenti tecnologici o software relativi al nostro prodotto.



Avvertenza: per ridurre il rischio di lesioni, l'utente deve leggere attentamente il manuale di istruzioni.

Elenco delle parti

1		Cremagliera	1
2		Sinistra e destra barre di supporto	2
3		Sinistra e Destra braccioni	2
4		Piastra della ruota	1
5		Piastra del cambio	1
6		Montaggio del cambio Braccio	1
7		Manopola M8* 20	2
8		Manopola M8* 40	2
9		Piedi	4
10		Vite M6*16	12
11		Vite M8*40	4
12		Vite M8*16	4
13		Dado M6	2
14		Dado M 8	8
15		Lavatrice 8	8

16		Chiave esagonale 5	1
17		Chiave esagonale 4	1
18		Ragazza 9-13	1
19		Cinghia di fissaggio	6

Installazione del prodotto

PASSAGGIO 1: Utilizzare 4 viti in gomma per fissare la parte inferiore della staffa per regolare il bilanciamento della staffa.

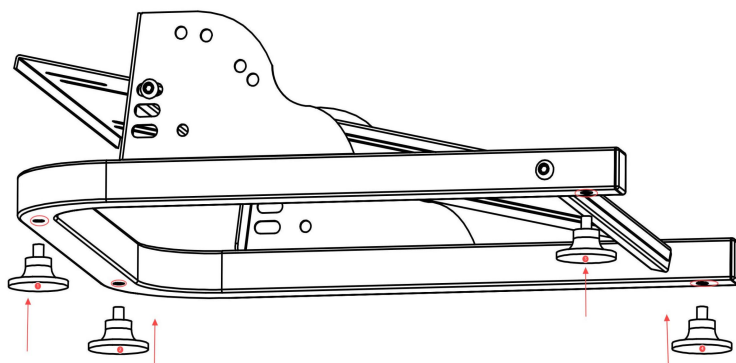

FASE 2: Per fissare la barra di supporto della staffa vengono utilizzate rispettivamente due manopole M8*40 e due viti M8*40.

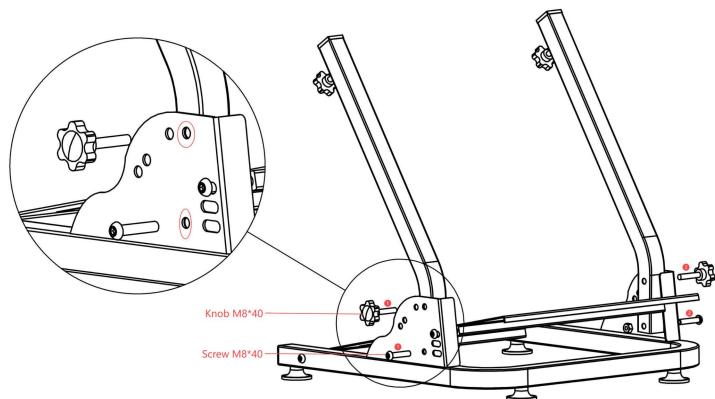

FASE 3: Inserire l'asta telescopica e fissarla con le viti M8*20, l'asta telescopica può essere regolata in altezza.

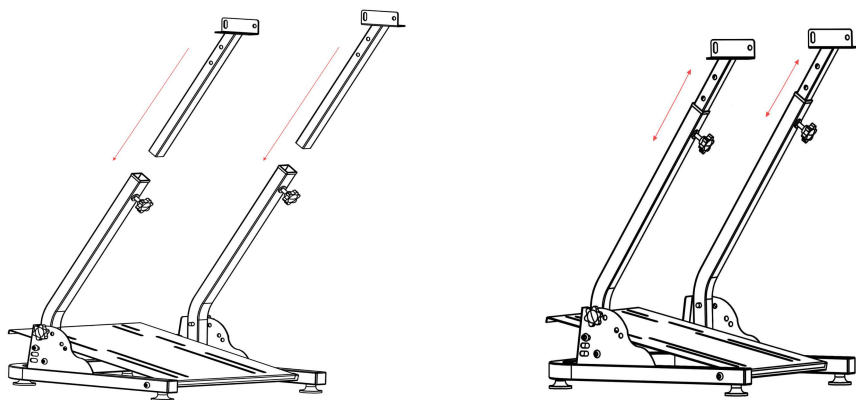

FASE 4: Inserire il pannello del volante e fissarlo con 4 viti M8*16 e dadi M8. L'angolazione del pannello del volante può essere regolata con precisione.

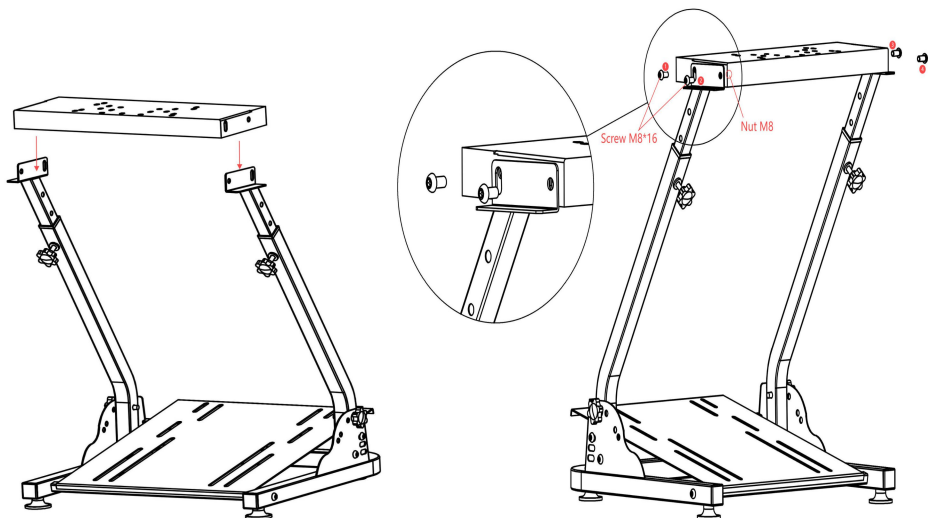

FASE 5: Installare la piastra di collegamento del vassoio partner, fissarla con 2 viti M8*40 e dadi.

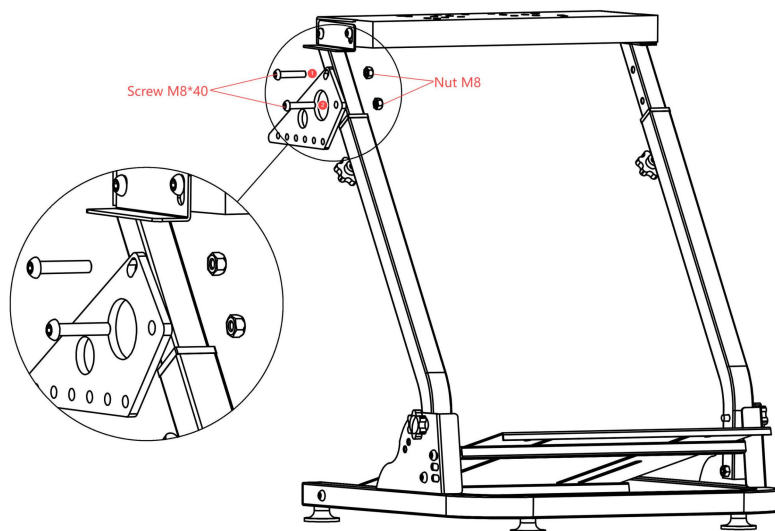

PASSO 6: Installare il pannello del disco partner e fissarlo con 2 viti M6*16 e dadi.

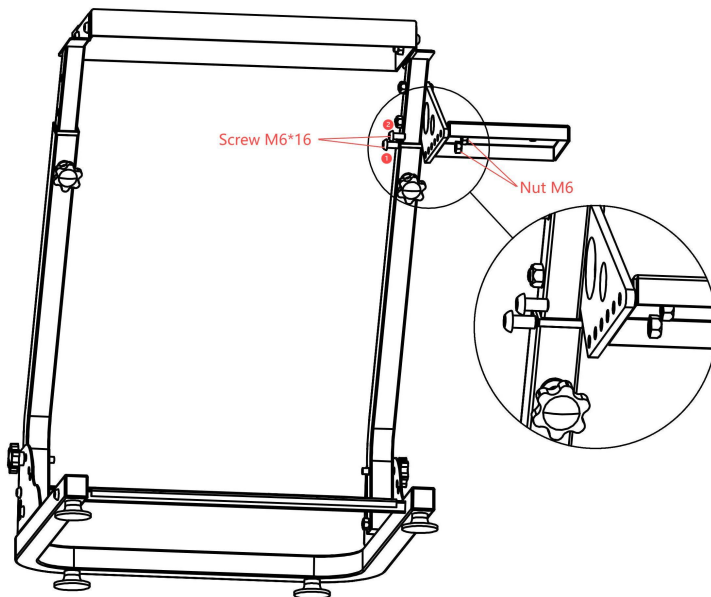

Installazione completata

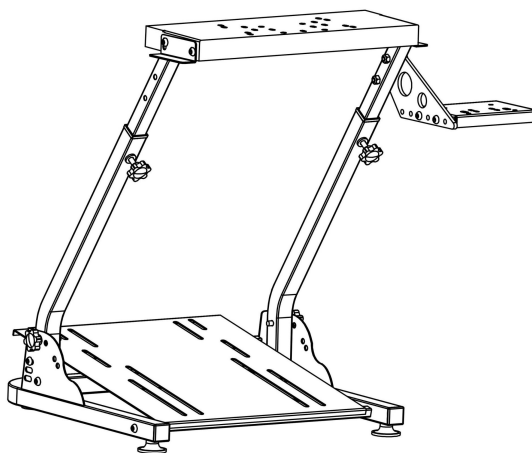

Gradini pieghevoli della staffa

1. Svitare le 2 viti M8*40 a manopola a sinistra e a destra sotto la staffa .
2. Ripiegare il supporto e riporlo contro la parete .

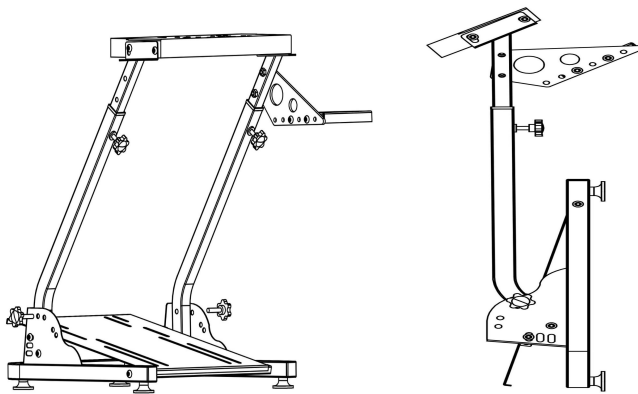

Produttore: Shanghaimuxinmuyeyouxiangongsi

Indirizzo: Shuangchenglu 803nong11hao1602A-1609shi, baoshanqu, shanghai 200000 CN.

Importato in AUS: SIHAO PTY LTD. 1 ROKEVA STREETEASTWOOD

Nuovo Galles del Sud 2122 Australia

Importato negli USA: Sanven Technology Ltd. Suite 250, 9166 Anaheim
Luogo, Rancho Cucamonga, CA 91730

UK	REP
-----------	------------

YH CONSULTING LIMITED. C/O YH Consulting
Limited Office 147, Centurion House, London
Road, Staines-upon-Thames, Surrey, TW18 4AX

EC	REP
-----------	------------

E-CrossStu GmbH
Mainzer Landstr.69,
60329 Frankfurt am Main.



VEVOR

Affordable. Reliable. Home Improvement.

SOPORTE PARA VOLANTE

MODELO: QY-GL08

VEVOR

Affordable. Reliable. Home Improvement.

STEERING WHEEL STAND

MODELO: QY-GL08

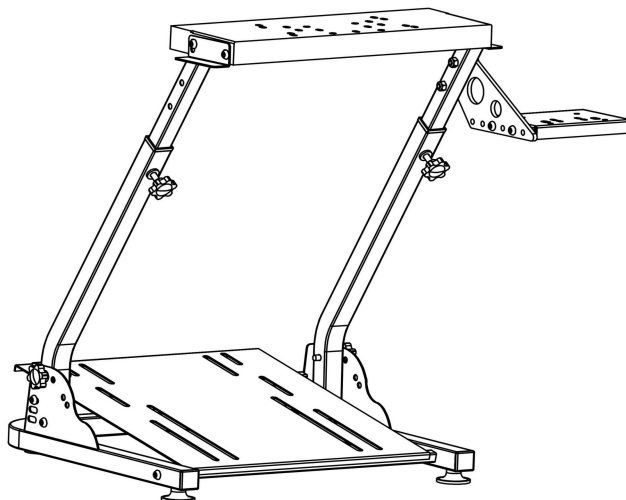







Estas son las instrucciones originales; lea atentamente todas las instrucciones del manual antes de utilizarlo. VEVOR se reserva el derecho de interpretar su manual de usuario. La apariencia del producto dependerá del producto que haya recibido. Le rogamos que nos disculpe si no le informamos de nuevo si hay actualizaciones tecnológicas o de software en nuestro producto.



Advertencia: Para reducir el riesgo de lesiones, el usuario debe leer atentamente el manual de instrucciones.

Lista de piezas

1		Estante	1
2		Izquierda y derecha varillas de soporte	2
3		Izquierda y derecha Apoyabrazos	2
4		Placa de rueda	1
5		Placa de cambio	1
6		Montaje de la palanca de cambios Brazo	1
7		Perilla M8* 20	2
8		Perilla M8* 40	2
9	Pies	4	
10		Tornillo M6*16	12
11		Tornillo M8*40	4
12		Tornillo M8*16	4
13		Tuerca M6	2

14		Tuerca M 8	8
15		Lavadora 8	8
16		Llave hexagonal 5	1
17		Llave hexagonal 4	1
18		Moza 9-13	1
19		Correa de encuadernación	6

Instalación del producto

PASO 1: Use 4 tornillos de goma para fijar la parte inferior del soporte para ajustar el equilibrio del soporte.

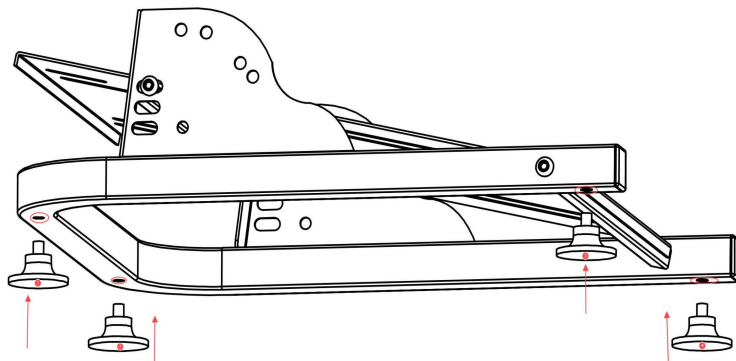

PASO 2: Se utilizan dos perillas M8*40 y dos tornillos M8*40 para fijar la barra de soporte del soporte respectivamente.

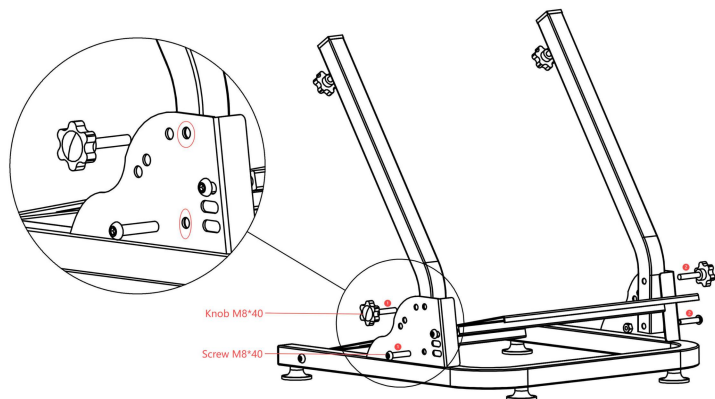

PASO 3: Inserte el poste telescópico y fíjelo con los tornillos de perilla M8 * 20, el poste telescópico se puede ajustar en altura.

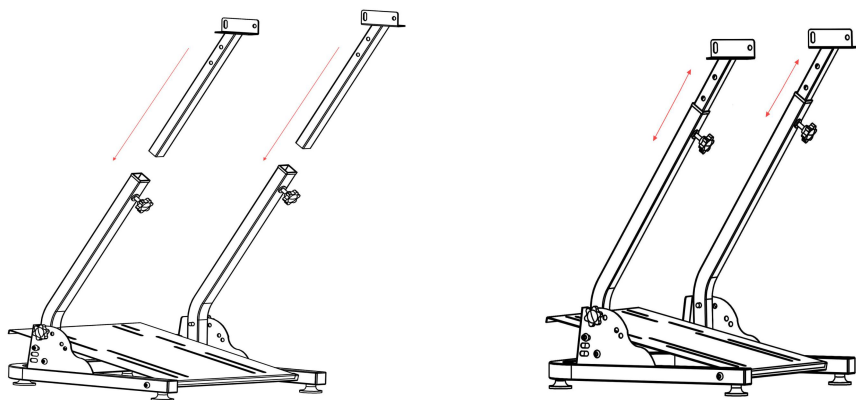

PASO 4: Colóquelo en el panel del volante y fíjelo con 4 tornillos M8*16 y tuercas M8. El ángulo del panel del volante se puede ajustar con precisión.

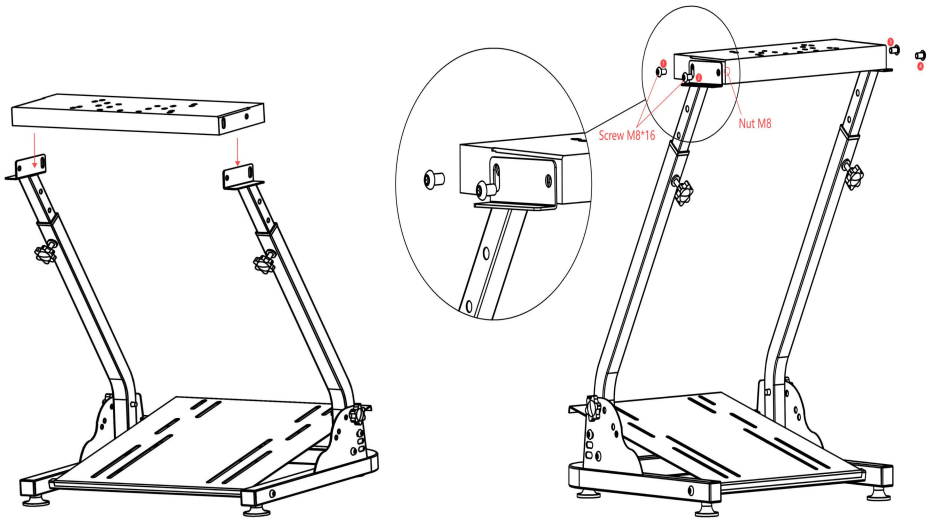

PASO 5: Instale la placa de conexión de la bandeja asociada, fijela con 2 tornillos y tuercas M8*40.

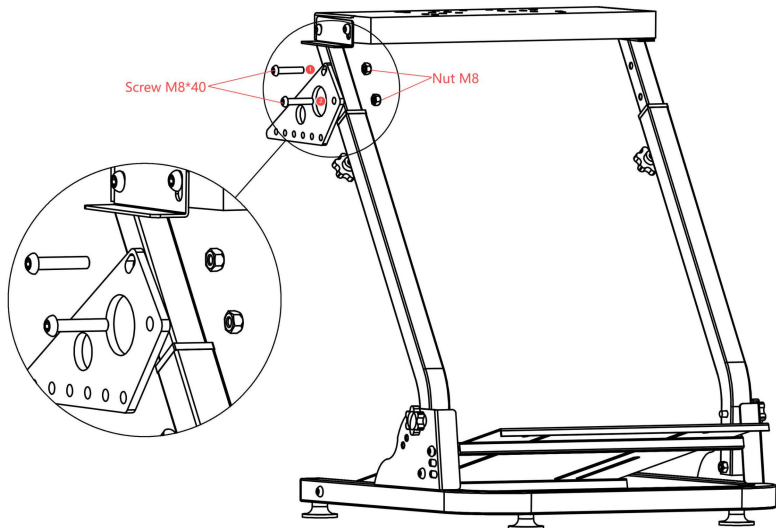

PASO 6: Instale el panel del disco asociado y fijelo con 2 tornillos y tuercas M6*16.

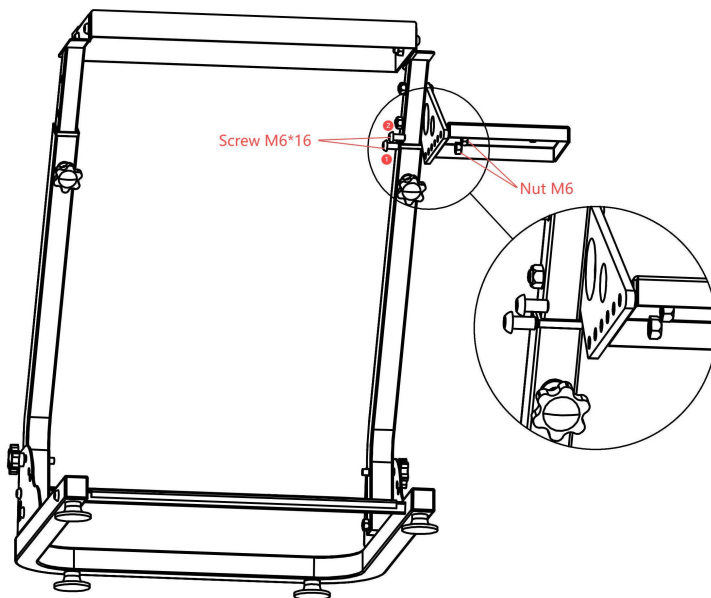

Instalación completada

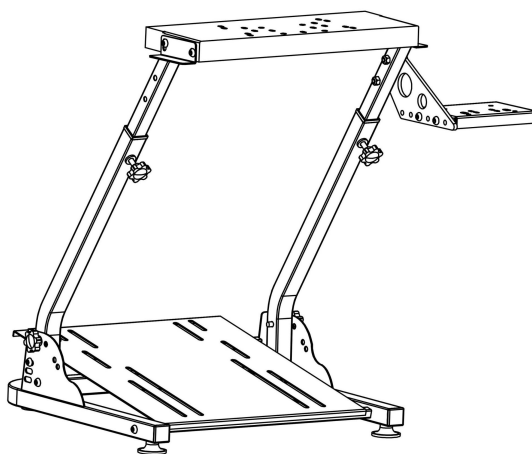

Escalones plegables de soporte

1. Desatornille los 2 tornillos de perilla M8*40 a la izquierda y a la derecha debajo del soporte .

2. Pliegue el soporte y guárdelo contra la pared .

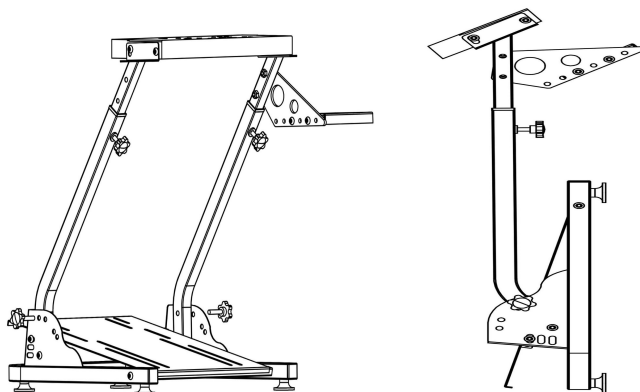

Fabricante: Shanghaimuxinmuyeyouxiangongsi

Dirección: Shuangchenglu 803nong11hao1602A-1609shi, baoshanqu, Shanghai 200000 CN.

Importado a AUS: SIHAO PTY LTD. 1 ROKEVA STREET, EASTWOOD

NSW 2122 Australia

Importado a EE. UU.: Sanven Technology Ltd. Suite 250, 9166 Anaheim
Lugar, Rancho Cucamonga, CA 91730

UK	REP
-----------	------------

YH CONSULTING LIMITED. C/O YH Consulting
Limited Office 147, Centurion House, London
Road, Staines-upon-Thames, Surrey, TW18 4AX

EC	REP
-----------	------------

E-CrossStu GmbH
Mainzer Landstr.69,
60329 Frankfurt am Main.



VEVOR

Affordable. Reliable. Home Improvement.

PODSTAWKA POD KIEROWNICĘ

MODEL: QY-GL08

VEVOR

Affordable. Reliable. Home Improvement.

STEERING WHEEL STAND

MODEL: QY-GL08

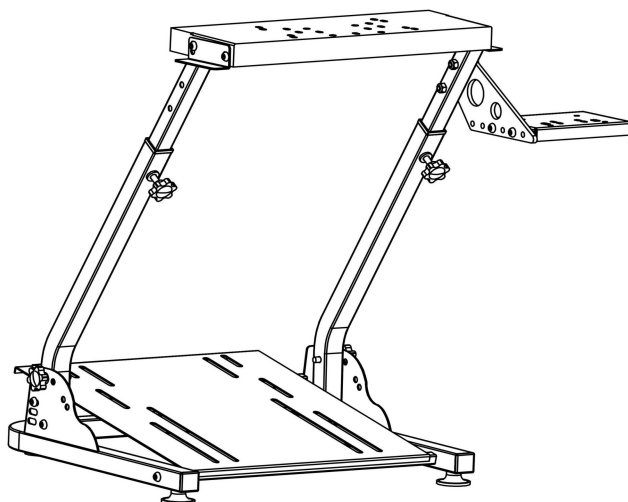











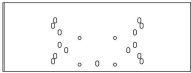





To jest oryginalna instrukcja obsługi. Przed użyciem prosimy o dokładne zapoznanie się z treścią instrukcji. Firma VEVOR zastrzega sobie prawo do jednoznacznej interpretacji niniejszej instrukcji obsługi. Wygląd produktu zależy od stanu, w jakim go otrzymali Państwo. Prosimy o wyrozumiałość, ale nie będziemy Państwa ponownie informować o aktualizacjach technologicznych lub oprogramowania naszego produktu.



Ostrzeżenie: Aby zminimalizować ryzyko obrażeń, użytkownik powinien uważnie przeczytać instrukcję obsługi.

Lista części

1		Stojak	1
2		Lewo i prawo pręty podporowe	2
3		Lewo i prawo Podłokietniki	2
4		Płyta koła	1
5		Płyta zmiany biegów	1
6		Montaż dźwigni zmiany biegów Ramię	1
7		Gałka M8* 20	2
8		Gałka M8* 40	2
9		Stopy	4
10		Śruba M6*16	12
11		Śruba M8*40	4
12		Śruba M8*16	4
13		Nakrętka M6	2
14		Nakrętka M 8	8
15		Podkładka 8	8

16		Klucz imbusowy 5	1
17		Klucz imbusowy 4	1
18		Dziewucha 9-13	1
19		Pasek wiążący	6

Instalacja produktu

KROK 1: Użyj 4 gumowych śrub, aby przymocować dolną część uchwyty aby wyregulować równowagę wspornika.

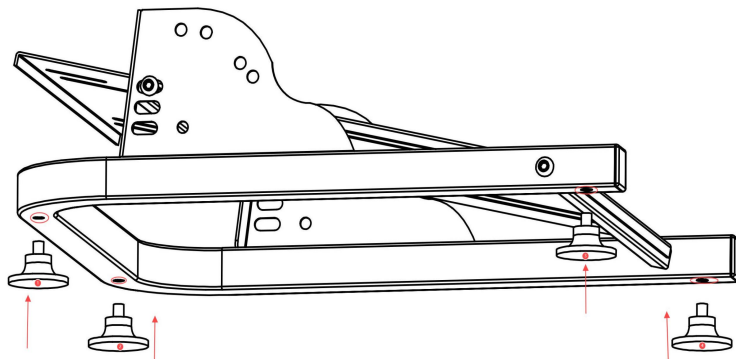

KROK 2: Do zamocowania wspornika użyj odpowiednio dwóch pokręteł M8*40 i dwóch śrub M8*40.

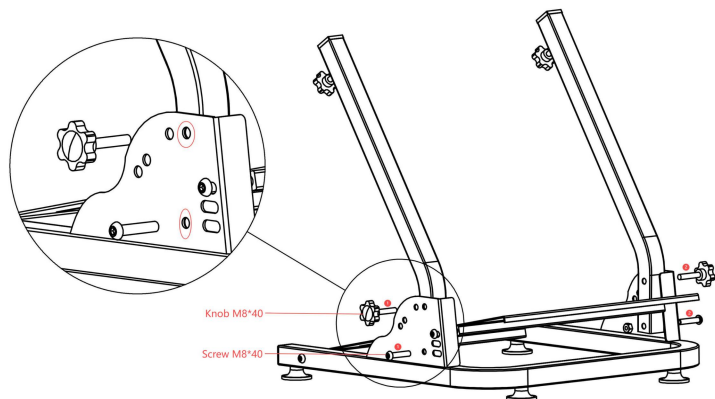

KROK 3: Włóż drążek teleskopowy i zamocuj go za pomocą śrub M8*20. Możesz regulować wysokość drążka teleskopowego.

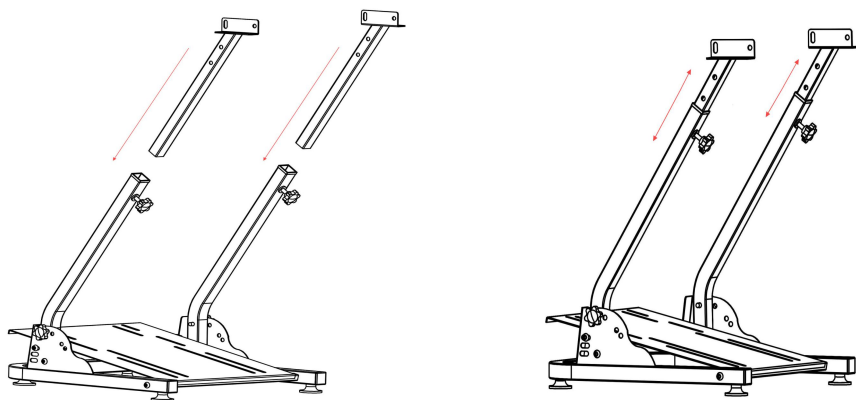

KROK 4: Umieść go w panelu kierownicy i zamocuj za pomocą 4 śrub M8*16 i nakrętek M8. Kąt panelu kierownicy można precyzyjnie wyregulować.

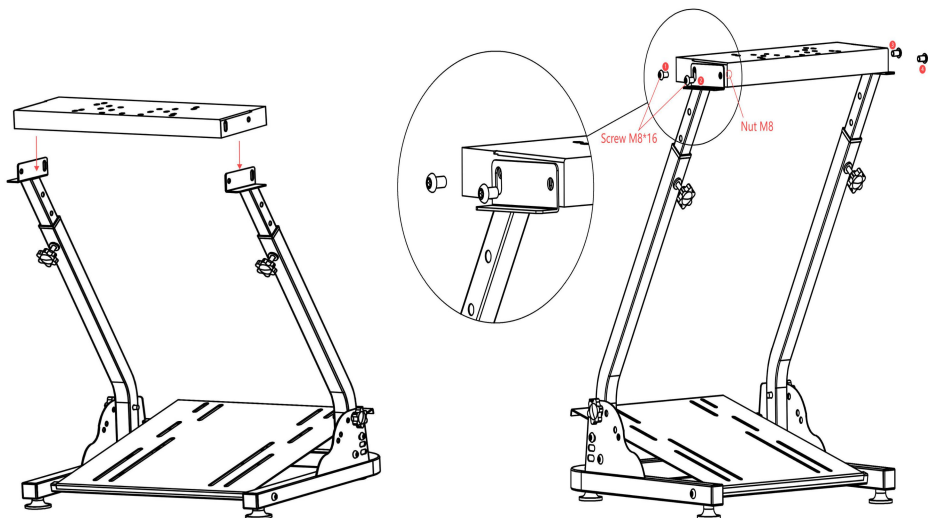

KROK 5: Zamontuj płytę łączącą tackę partnerską, przymocuj ją za pomocą 2 śrub M8*40 i nakrętek.

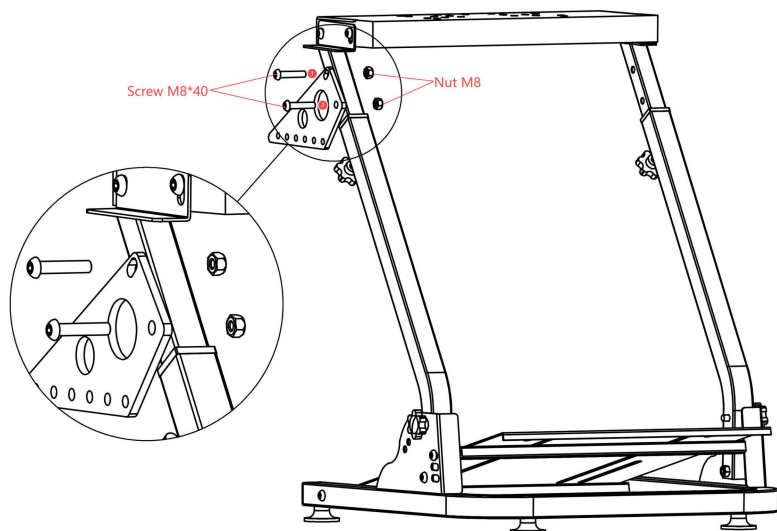

KROK 6: Zamontuj panel dysku partnerskiego i przymocuj go za pomocą 2 śrub M6*16 i nakrętek.

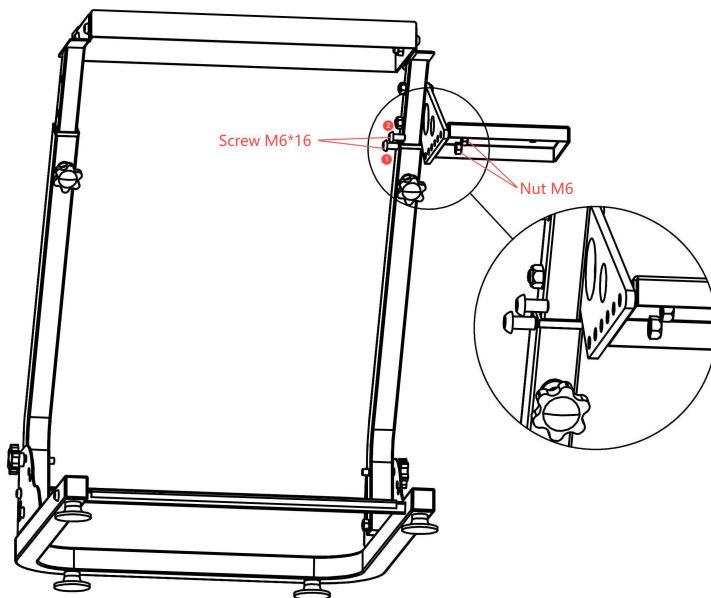

Instalacja ukończona

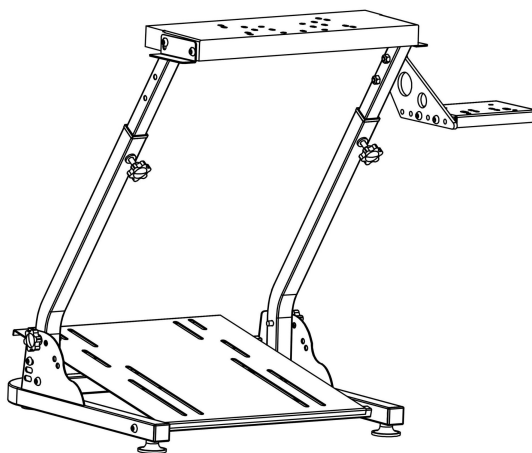

Składane stopnie wspornika

1. Odkręć 2 śruby M8*40 z lewej i prawej strony pod wspornikiem .
2. Złóż stojak i schowaj go przy ścianie .

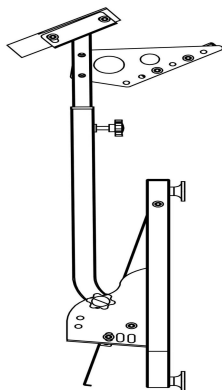
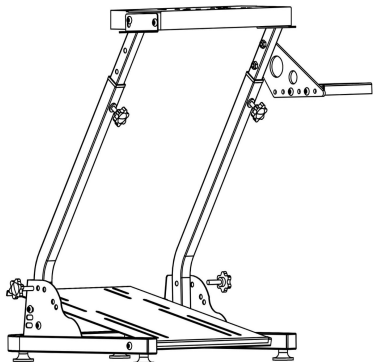

Producent: Shanghai muxinmuyeyouxiangongsi

Adres: Shuangchenglu 803nong11hao1602A-1609shi, baoshanqu, szanghaj 200000 CN.

Importowane do AUS: SIHAO PTY LTD. 1 ROKEVA STREET EASTWOOD

NSW 2122 Australia

Importowane do USA: Sanven Technology Ltd. Suite 250, 9166 Anaheim
Miejsce, Rancho Cucamonga, CA 91730

UK	REP
-----------	------------

YH CONSULTING LIMITED. C/O YH Consulting
Limited Office 147, Centurion House, London
Road, Staines-upon-Thames, Surrey, TW18 4AX

EC	REP
-----------	------------

E-CrossStu GmbH
Mainzer Landstr.69,
60329 Frankfurt am Main.



VEVOR

Affordable. Reliable. Home Improvement.

Stuurwielstandaard

MODEL: QY-GL08

VEVOR

Affordable. Reliable. Home Improvement.

STEERING WHEEL STAND

MODEL: QY-GL08

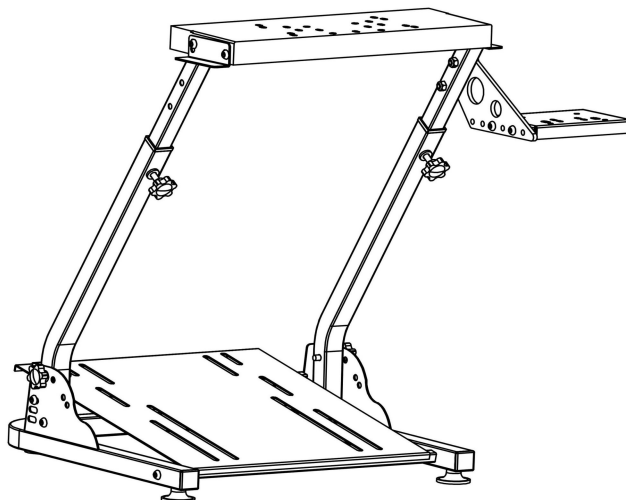











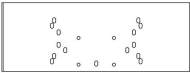







Dit is de originele handleiding. Lees alle instructies zorgvuldig door voordat u het product gebruikt. VEVOR behoudt zich het recht voor om de gebruiksaanwijzing duidelijk te interpreteren. Het uiterlijk van het product is afhankelijk van het product dat u hebt ontvangen. Neemt u het ons niet kwalijk dat we u niet meer op de hoogte stellen van eventuele technologische of software-updates voor ons product.



Waarschuwing: om het risico op letsel te verminderen, dient de gebruiker de gebruiksaanwijzing zorgvuldig te lezen.

Onderdelenlijst

1		Rek	1
2		Links en rechts steunstaven	2
3		Links en rechts Armleuningen	2
4		Wielplaat	1
5		Schakelplaat	1
6		Shifter Montage Arm	1
7		Knop M8* 20	2
8		Knop M8* 40	2
9		Voeten	4
10		Schroef M6*16	12
11		Schroef M8*40	4
12		Schroef M8*16	4
13		Moer M6	2
14		Moer M 8	8
15		Wasmachine 8	8

16		Inbussleutel 5	1
17		Inbussleutel 4	1
18		Meid 9-13	1
19		Bindband	6

Productinstallatie

STAP 1: Gebruik 4 rubberen schroeven om de onderkant van de beugel vast te zetten om de balans van de beugel aan te passen.

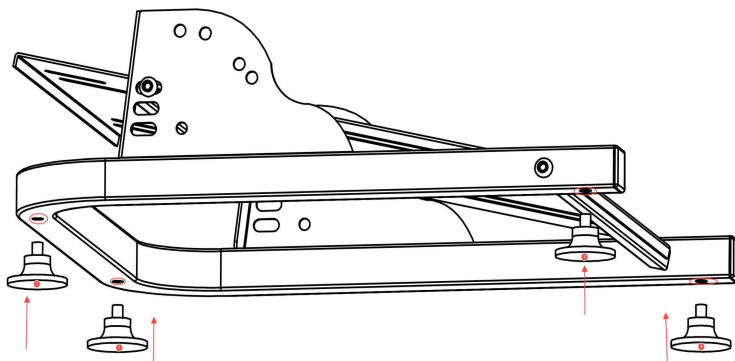

STAP 2: Twee knoppen M8*40 en twee schroeven M8*40 worden gebruikt om de beugelsteunbalk te bevestigen.

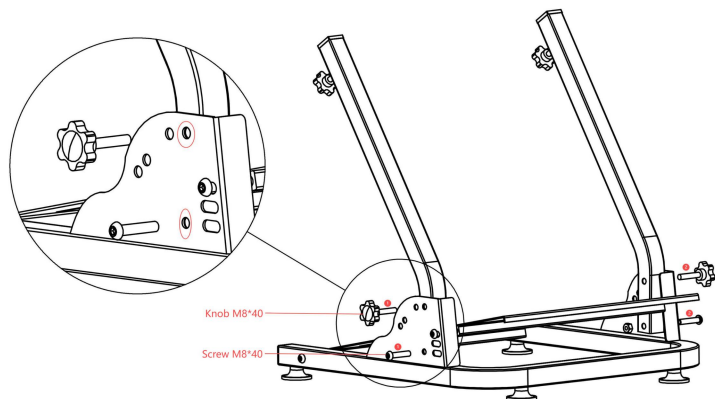

STAP 3: Plaats de telescopische paal en bevestig deze met de M8*20-schroeven. De telescopische paal is in hoogte verstelbaar.

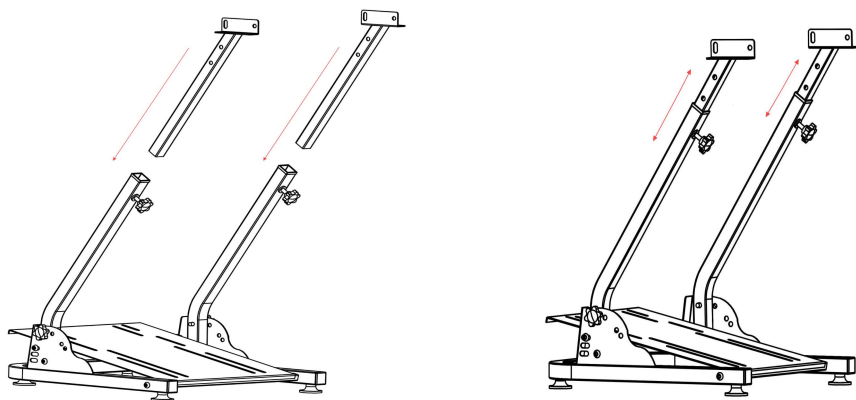

STAP 4: Plaats het in het stuurwielpaneel en bevestig het met 4 M8*16 schroeven en M8 moeren. De hoek van het stuurwielpaneel kan nauwkeurig worden afgesteld.

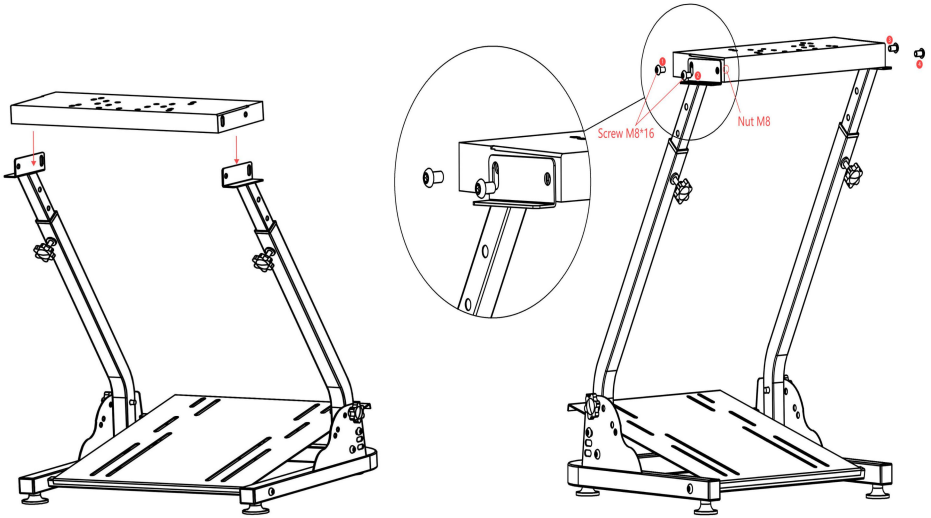

STAP 5: Plaats de verbindingsplaat van de partnerbak en bevestig deze met 2 M8*40 schroeven en moeren.

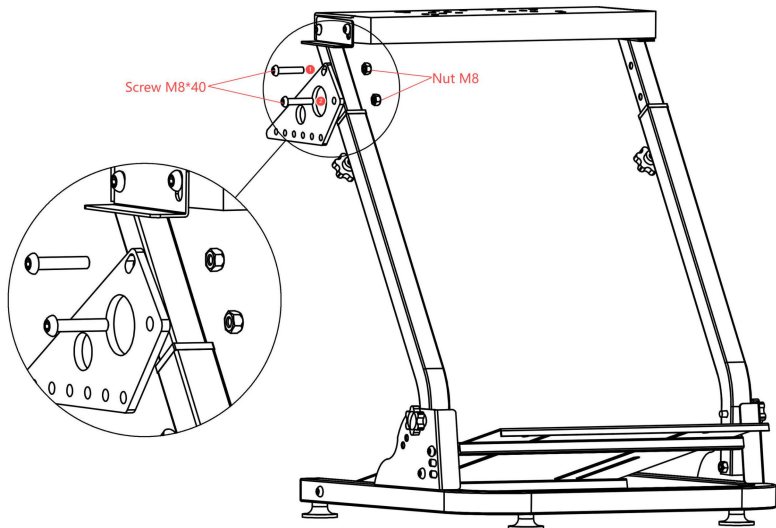

STAP 6: Plaats het partnerschijfpaneel en bevestig het met 2 M6*16 schroeven en moeren.

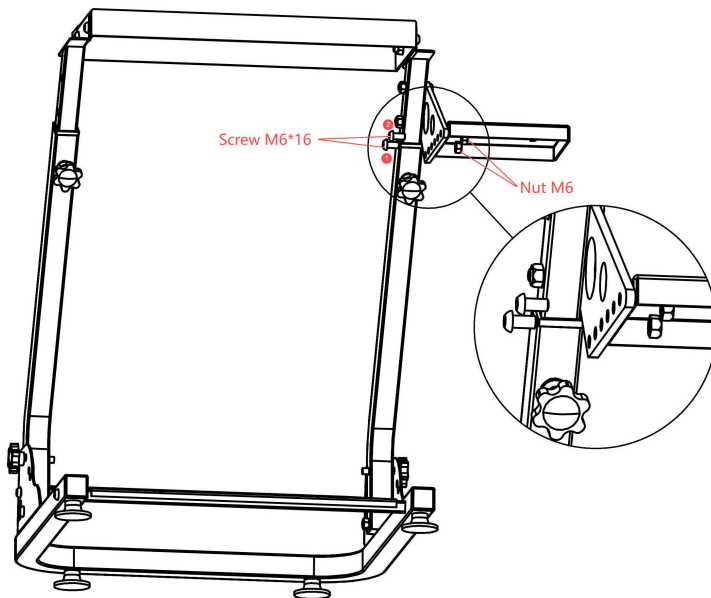

Installatie voltooid

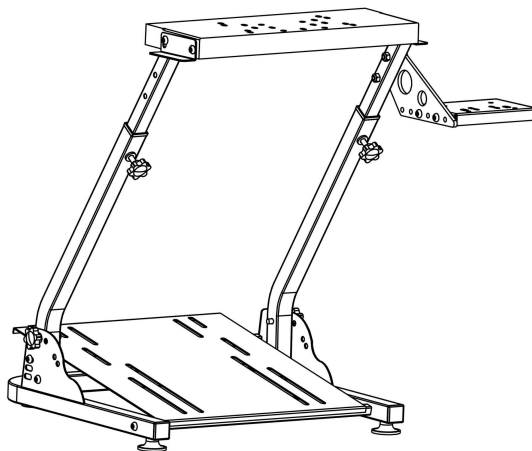

Opvouwbare treden van de beugel

1. Draai de 2 M8*40-knopschroeven links en rechts onder de beugel los .
2. Vouw de standaard op en bewaar deze tegen de muur .

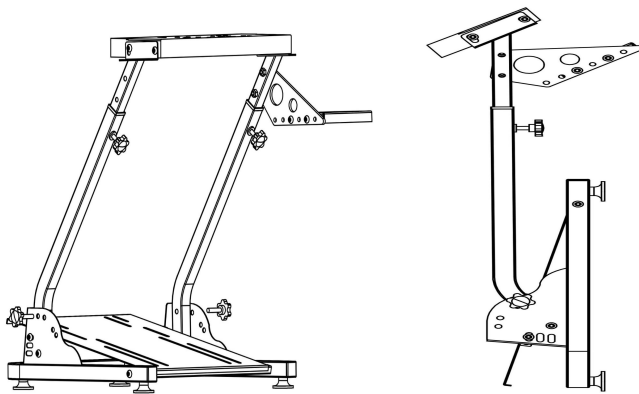

Fabrikant: Shanghaimuxinmuyeyouxiangongsi

Adres: Shuangchenglu 803nong11hao1602A-1609shi, baoshanqu, shanghai 200000 CN.

Geïmporteerd naar AUS: SIHAO PTY LTD. 1 ROKEVA STREETEASTWOOD

NSW 2122 Australië

Geïmporteerd naar de VS: Sanven Technology Ltd. Suite 250, 9166
Anaheim

Plaats, Rancho Cucamonga, CA 91730

UK	REP
-----------	------------

YH CONSULTING LIMITED. C/O YH Consulting
Limited Office 147, Centurion House, London
Road, Staines-upon-Thames, Surrey, TW18 4AX

EC	REP
-----------	------------

E-CrossStu GmbH
Mainzer Landstr.69,
60329 Frankfurt am Main.



VEVOR

Affordable. Reliable. Home Improvement.

RATTSTYCK

MODELL: QY-GL08

VEVOR

Affordable. Reliable. Home Improvement.

STEERING WHEEL STAND

MODELL: QY-GL08

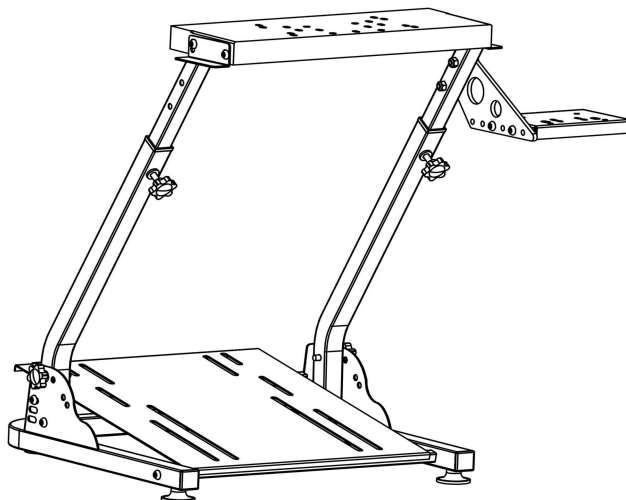











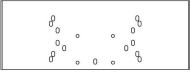

Detta är originalinstruktionerna, vänligen läs alla instruktioner noggrant innan du använder produkten. VEVOR förbehåller sig en tydlig tolkning av vår användarmanual. Produktens utseende ska vara beroende av den produkt du mottagit. Vi ber om ursäkt för att vi inte kommer att informera dig igen om det finns några teknik- eller programuppdateringar för vår produkt.



Varning – För att minska risken för skador måste användaren läsa instruktionsmanualen noggrant.

Dellista

1		Kuggstång	1
2		Vänster och höger stödstånger	2
3		Vänster och höger Armstöd	2
4		Hjulplatta	1
5		Växelplatta	1
6		Växelreglagemo ntering Ärm	1
7		Knopp M8* 20	2
8		Knopp M8* 40	2
9		Fötter	4
10		Skruv M6*16	12
11		Skruv M8*40	4
12		Skruv M8*16	4
13		Mutter M6	2
14		Mutter M8	8

15		Bricka 8	8
16		Sexkantsnyckel 5	1
17		Sexkantsnyckel 4	1
18		Tjej 9-13	1
19		Bindrem	6

Produktinstallation

STEG 1: Använd 4 gummiskruvar för att fästa fästets undersida för att justera balansen på fästet.

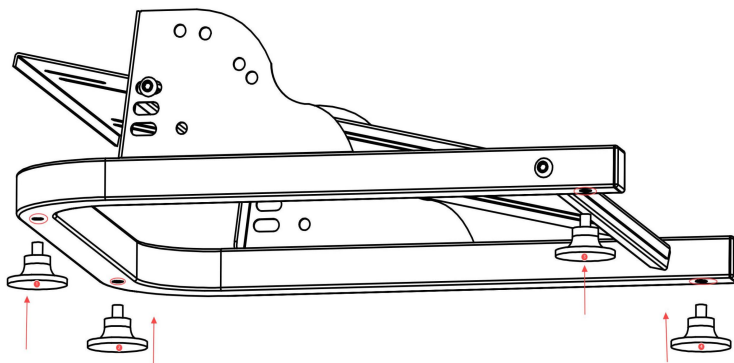

STEG 2: Två M8*40-knoppar och två M8*40-skrivar används för att fästa fästets stödstång.

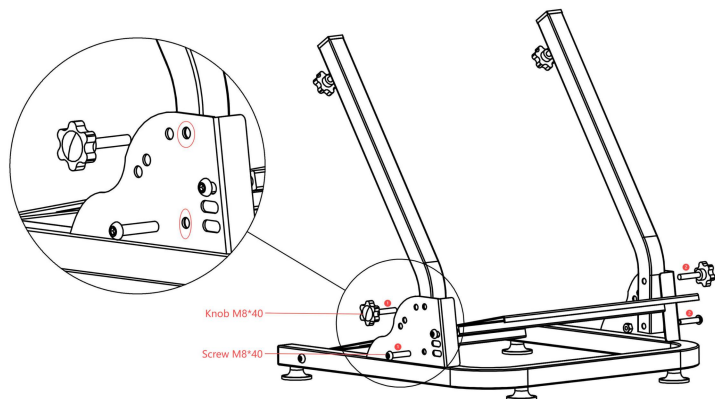

STEG 3: Sätt i teleskopstången och fäst den med skruvar M8*20. Teleskopstången kan justeras i höjd.

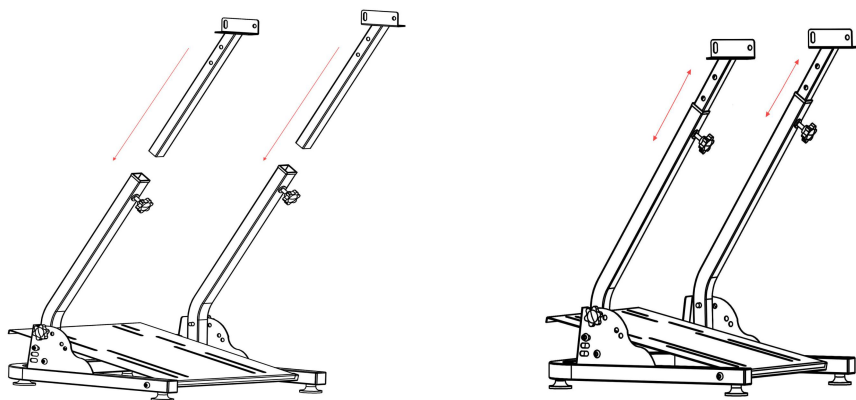

STEG 4: Sätt den i rattpanelen och fäst den med 4 M8*16-skruvar och M8-muttrar. Rattpanelens vinkel kan finjusteras.

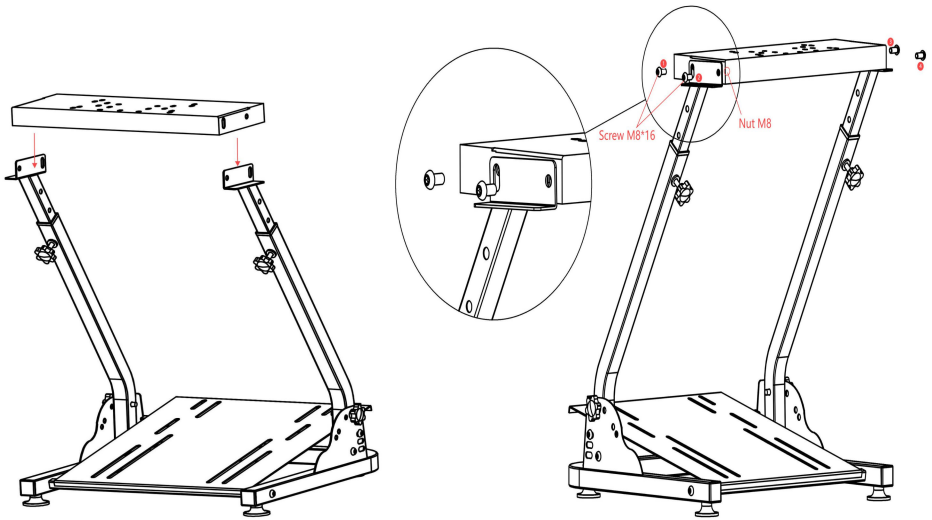

STEG 5: Montera partnerfackets anslutningsplatta och fäst den med 2 M8*40 skruvar och muttrar.

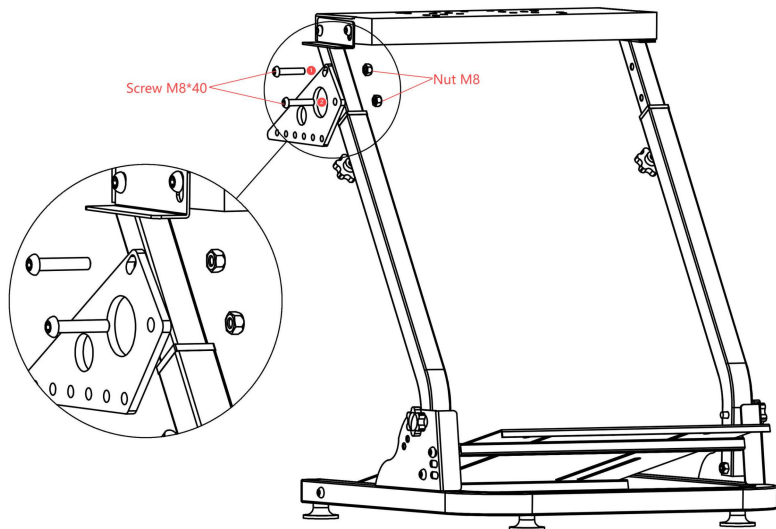

STEG 6: Montera partnerskivpanelen och fäst den med 2 M6*16 skruvar och muttrar.

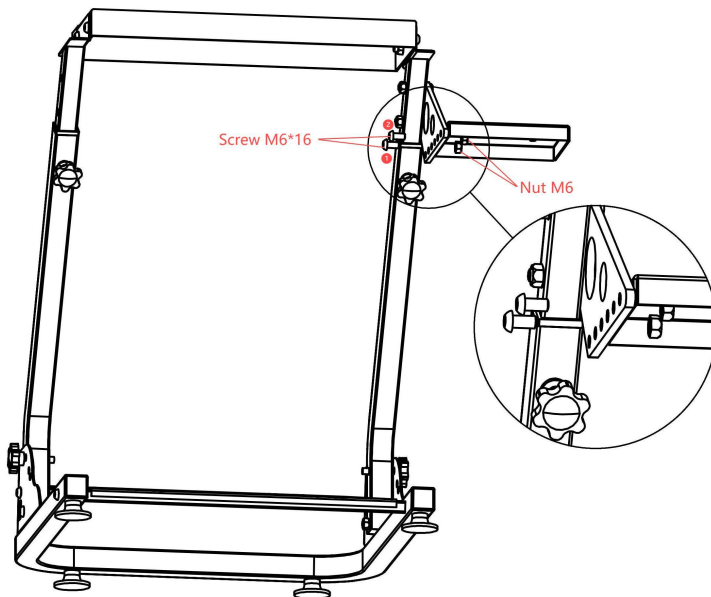

Installationen är klar

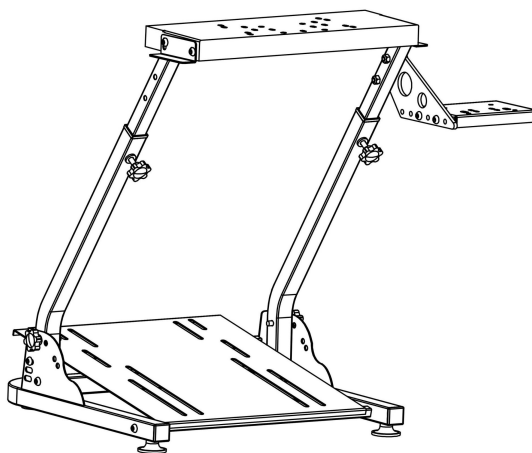

Fällbara steg av fäste

1. Skruva loss de 2 M8*40-skruvarna med knapp till vänster och höger under fästet .

2. Vik ihop stativet och förvara det mot väggen .

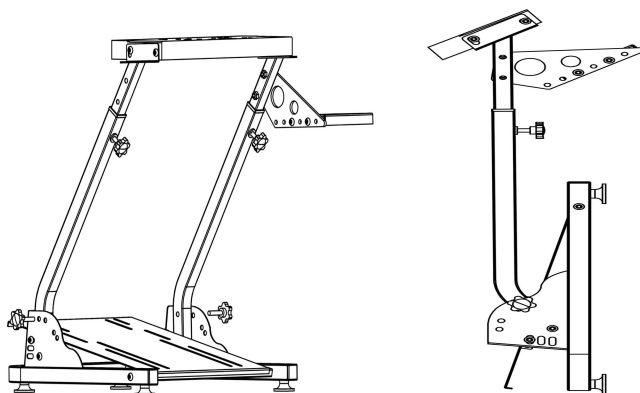

Tillverkare: Shanghaimuxinmuyeyouxiangongsi

Adress: Shuangchenglu 803nong11hao1602A-1609shi, baoshanqu,
Shanghai 200 000 kanadensiska republiken.

Importerad till Australien: SIHAO PTY LTD. 1 ROKEVA
STREETEASTWOOD

NSW 2122 Australien

Importerad till USA: Sanven Technology Ltd. Suite 250, 9166 Anaheim
Plats, Rancho Cucamonga, Kalifornien 91730

UK	REP
-----------	------------

YH CONSULTING LIMITED. C/O YH Consulting
Limited Office 147, Centurion House, London
Road, Staines-upon-Thames, Surrey, TW18 4AX

EC	REP
-----------	------------

E-CrossStu GmbH
Mainzer Landstr.69,
60329 Frankfurt am Main.

