

# DDR CUTTING MACHINE

## RCS-100B/110B/125B

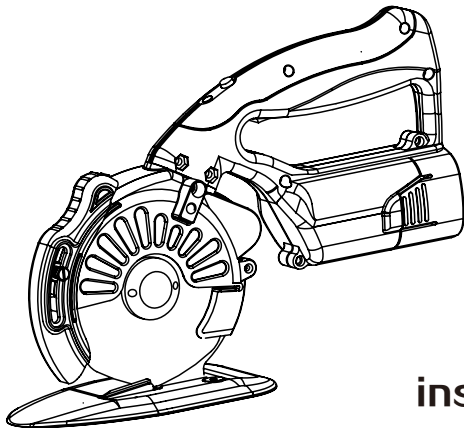

instruction manual

# PARTSASSEMBLYDRAWING

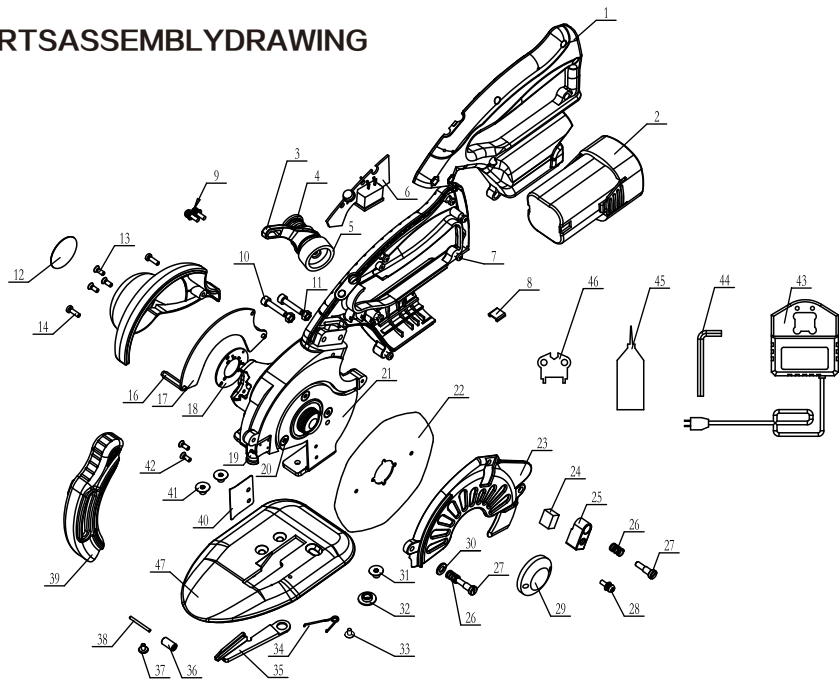

NO.	Parts Name	NO.	Parts Name	NO.	Parts Name
1	Drive handle	17	Main control panel	32	Two steps nut
2	14.8vLi-ion battery	18	Hall panel	33	M3*6Step screw
3	Shapener frame	19	LED light	34	Under knife spring
4	Pressure spring	20	M4*8Screw	35	Under knife
5	Gring wheel	21	Standard	36	Roller
6	Button panel	22	Knife	37	M3*5Screw
7	M3*10Self-tapping screw	23	Shield	38	Roller shaft(rear)
8	Socket connector	24	Oil felt	39	Knife guard
9	M4*12Combination screw	25	Kinifer Oiler	40	Separator
10	4*20Inner hexagon screw	26	Pressure spring	41	M5*6Inner hexagon screw
11	M4Nut	27	Screw for oiler	42	M3*4Sunk screw
12	Φ28Lable	28	M3*10Combination screw	43	Charger
13	M3*8*4Screw	29	Blade pressure plate	44	Internal Hexagon Wrench
14	M3*10Screw	30	4.5*9*0.8Terminal plate	45	Oiler
15	Cover	31	M5*7Inner hexagon screw	46	Butterfly wrench
16	M3*26Hexagon screw insulated column			47	Chassis

## PRODUCT BRIEF INTRODUCTION

This product uses the micro large torque servo motor to drive the blade directly, Gearless transmission mechanism, it has energy saving, environmental protection, safety, light, durable and so on advantages, It is a pioneer in the international industry and has completely independent intellectual property rights.

This product implements the standard requirements of T/ZZB 0788-2018 "Direct Drive Round Cutter Cutting Machine", and meets the requirements of EMC/LVD/MD certification.

**★ Please check the packing list before unpacking**

### List

No.	Description	Quantity	No.	Description	Quantity
1	Servo Cutting Machine	1SET	6	Butterfly wrench	1PC
2	Lithium battery	2SETS	7	M3 internal hexagon wrench	1PC
3	Charger	1PC	8	Sandpaper	1PC
4	Grinding wheel	1PC	9	Certificate of approval	1PC
5	Lubricating oil	1PC	10	Instructions	1PC

### Parameter list

Model	voltage	Power	Speed	Battery capacity	Charging time	Charging Current
RCS-100B	14.8V	3.6-150W	800\950\1100\1250\1400RPM	2500mAh	120minutes	2A
RCS-110B	14.8V	3.6-150W	800\950\1100\1250\1400RPM	2500mAh	120minutes	2A
RCS-125B	14.8V	3.6-180W	800\950\1100\1250\1400RPM	2500mAh	120minutes	2A

# INSTRUCTIONS

**Step1**lithium battery installation: Before installing the lithium battery, please keep the power switch in the "O" position and install the lithium battery into the battery slot of the cutting machine. Please pay attention to the insertion direction of the battery, Battery shrapnel lock, as shown in picture 1

**Step2**Power on: Switch to "—" closed power supply, Red Light; "multi function key" double-click "multi function key" , round knife 800rpm operation.

**Step3**Power off: Switch to "O" , disconnect power supply.

**Step4**Adjust Speed : when running, Click "multi function key" ,speed can be carried out. Click "multi function key" , circulate speed within 800/950/1100/1250/1400rpm

**Step5**Turn on/off: the LED lights. Press multi-function button for 3 seconds to turn on the LED lamp, and press for 3 seconds to turn off the LED lamp.

**Step6:**Cutting.: First let the power supply in the closed state, pull the knife protector to the appropriate position, start the cutting knife, adjust to the appropriate speed,cutting operation.When cutting,the body part should be removed from the blade so as not to be damaged.

**Step7**Lithium battery charging: Insert the charger into the appropriate power socket, the green light will be on, and the lithium battery will be inserted into the charging tank in the prescribed direction. After 120 minutes of charging, the charger will be charged and the power supply will be unplugged.

## Guide for replacement of blades and grinding wheels

**Important tips:** Before changing blades or grinding wheels, the lithium batteries must be removed to ensure that the machine is in a power-off state (the red power lamp above the handle goes out), and the replacement operation is strictly prohibited under the condition of power-on.

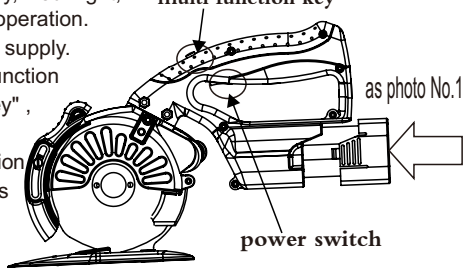

### ★ Replace blade

Step1: Remove the three bolts on the shield and remove the shield.

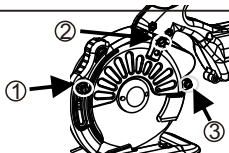

Step 3: Insert the inner hexagonal wrench into the blade and the hole of the rack plate, lock the blade, then insert the butterfly wrench into the locking nut, loosen the nut counterclockwise, and remove the old blade.

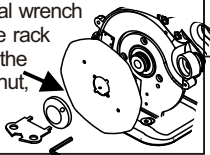

Step2: Align the positioning holes on the blade with the positioning holes on the back cushion.

Step 4: Install a new blade. Please note that the blade positioning groove matches the blade positioning tip.

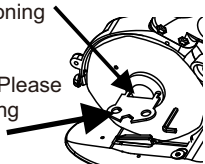

### ★ Replace grinding wheel

Hold the wheel's outer circle with your hand, insert the bolt into the positioning hole on the shaft, lock the wheel, then rotate in the direction indicated by the arrow, remove the old wheel and replace it with a new one.

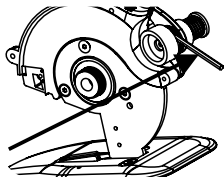

### Inspection and maintenance

★Oil injection: In order to ensure the best performance and life of the machine, please always keep the lubricating oil pot in an oily state, about 30-40 hours oil injection once.

★Grinding knife: Make sure the blade is sharp. Start the cutting machine to make the blade run at the lowest speed. The grinding wheel cap of the cutter is grinded by finger light side pressing, so that the grinding wheel and the blade touch slightly, the grinding wheel and the blade rotate synchronously until the edge of the cutter is sharp, the grinding tool is finished.

★ Clean grinding wheel oil pollution: When more oil pollution deposits on the contact surface of grinding wheel grinding tool affects the function of grinding tool, it is necessary to clean the oil pollution on the grinding wheel in time, remove the grinding wheel and use grinding paper to clean it. Dismantling

and assembling method of grinding wheel, Please refer to this manual.

★ Inspection of installation screw: In order to ensure the best performance and operation safety of the cutting machine, it is necessary to check whether the installation screw is tightened properly. If the screw is loose, it should be tightened again immediately. Otherwise, it will lead to serious accidents and ensure that the cutting machine is clean and dry.

Safety precautions

1. Workplaces should be kept clean and tidy, No sundries..
2. Workplace ambient temperature should be - 10 C - 45 C, and relative humidity should be less than 85%.
3. The blade is sharp. It is strictly forbidden to touch the body. Please use it carefully after the power is turned on, and children are forbidden to approach.
4. When the machine is not working, the cutter protector should be kept in the lowest position.
5. Before using the product, please inspect it visually to ensure the safety device is normal and the installation of screw and blade is safe.
6. If the cutting resistance is large and the cutting is not smooth, the cutting force should not be pushed hard. It is necessary to check whether the blade is sharp and whether the cutting material is too thick or too hard.
7. Before maintenance, please make sure that the battery is removed and the power supply is cut off, and the red power indicator is off.
8. In addition to routine maintenance, replacement of blades and grinding wheels, do not replace any other parts at will.
9. Connect the ground wire to ensure safety.

Notes: The company's products are being improved at any time to adapt to the latest technological progress. Therefore, some parts may be improved without prior notice. For improvement, the specifications contained in this manual may not be changed without prior notice.

## Warranty Card

User's address	
Model	
Sales Company	
Series No.	
Sales Company	
Fault description	
Date of manufacture	
Date of purchase	

## Quality Service Commitment

This product will be repaired free of charge within two years when it is in normal use and no man-made damage occurs from the date of leaving the factory. Customers can inform the manufacturer by telephone, letter and other modern communication if they have service needs in the process of using the product, and the manufacturer can make processing reply within 24 hours.

Unauthorized maintenance, modification or replacement of services that will not be subject to factory warranty