

VEVOR[®]

TOUGH TOOLS, HALF PRICE

Technical Support and E-Warranty Certificate www.vevor.com/support

POULTRY FEEDER

USER MANUAL

We continue to be committed to provide you tools with competitive price. "Save Half", "Half Price" or any other similar expressions used by us only represents an estimate of savings you might benefit from buying certain tools with us compared to the major top brands and does not necessarily mean to cover all categories of tools offered by us. You are kindly reminded to verify carefully when you are placing an order with us if you are actually saving half in comparison with the top major brands.

VEVOR[®]

TOUGH TOOLS, HALF PRICE

POULTRY FEEDER

CF-06H



NEED HELP? CONTACT US!

Have product questions? Need technical support? Please feel free to contact us:

Technical Support and E-Warranty Certificate
www.vevor.com/support

This is the original instruction, please read all manual instructions carefully before operating. VEVOR reserves a clear interpretation of our user manual. The appearance of the product shall be subject to the product you received. Please forgive us that we won't inform you again if there are any technology or software updates on our product.

WARNING:

Read this manual before using this product. Failure to do so can result in serious injury.

Assembly precautions

1. Assemble only according to these instructions. Improper assembly can create hazards.
2. Wear ANSI-approved safety goggles and heavy-duty work gloves during assembly.
3. Keep the assembly area clean and well-lit.
4. Keep bystanders out of the area during assembly.
5. Do not assemble when tired or when under the influence of alcohol, drugs or medication.
6. Product capabilities apply to properly and completely assembled products only.
7. Assemble on a flat, level, hard and smooth surface capable of safely supporting a fully loaded feeder.
8. For additional information regarding the parts listed in the following pages, please refer to the Assembly Diagram of this manual. Unwrap and separate all parts in a clean work area.

Use precautions

TO PREVENT SERIOUS INJURY AND DEATH FROM TIPPING:

1. DO NOT SIT, STAND OR CLIMB ON THIS ITEM.
2. This product is not a toy or a toy chest. Do not allow children to play with this item. Use as intended only. If needed, please supervise the children to understand step & open rules of the feeder.
3. Empty, close, and lock the feeder before moving.
4. Use only on a flat, level, hard and smooth surface capable of safely supporting a fully loaded feeder.

Product Dimension:

18.89x15.94x11.22 inch / 480x405x285 mm



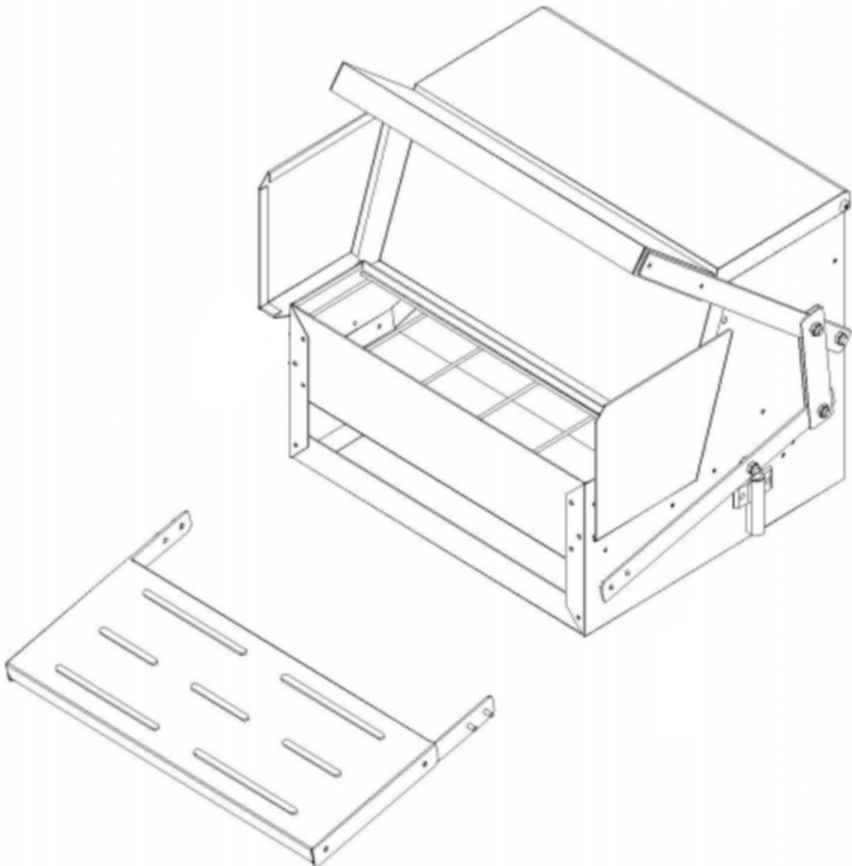
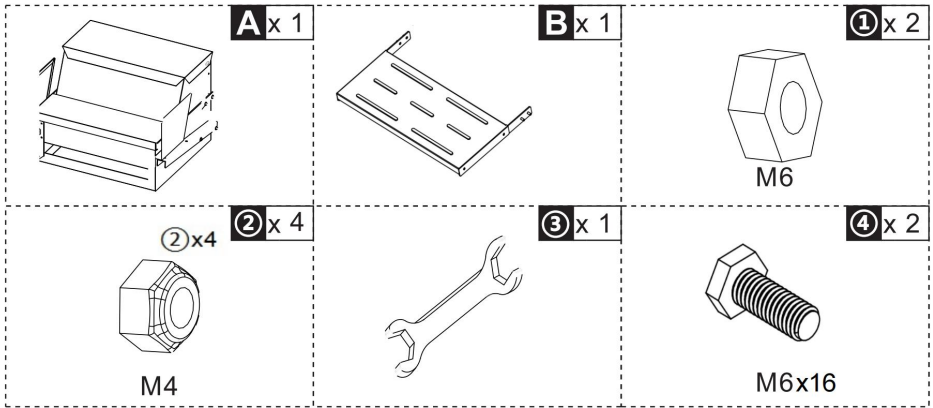

Prepare Body A and Pedal B.

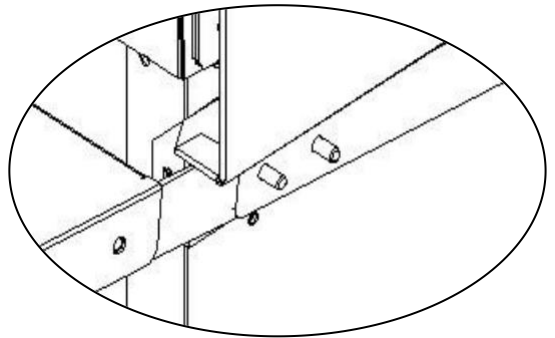
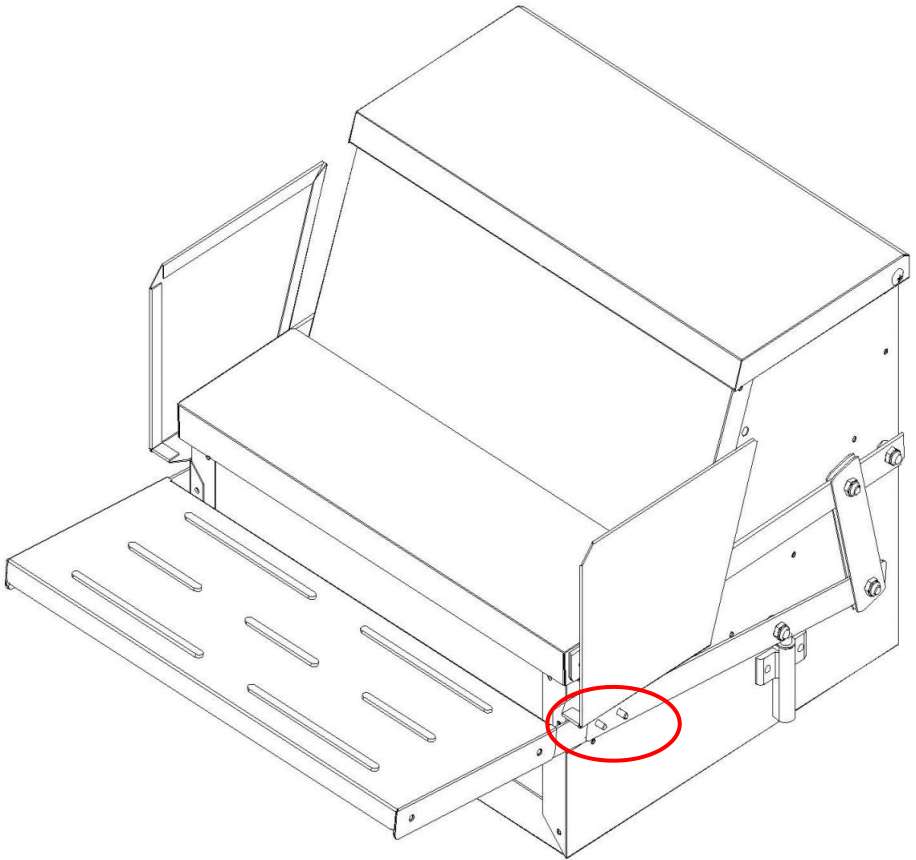

Align the 4 posts of pedal B and the hole positions of body A to assemble.

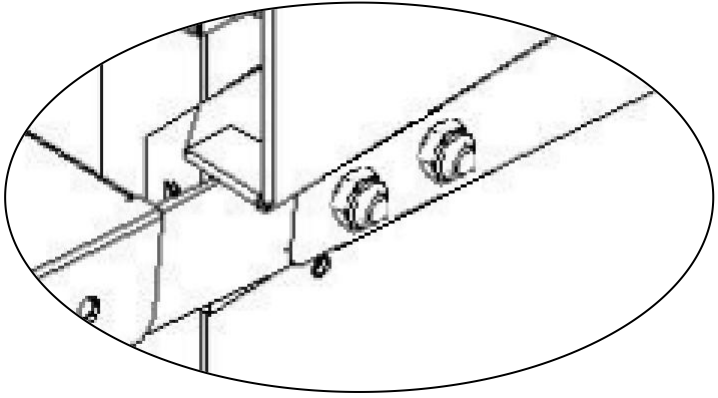
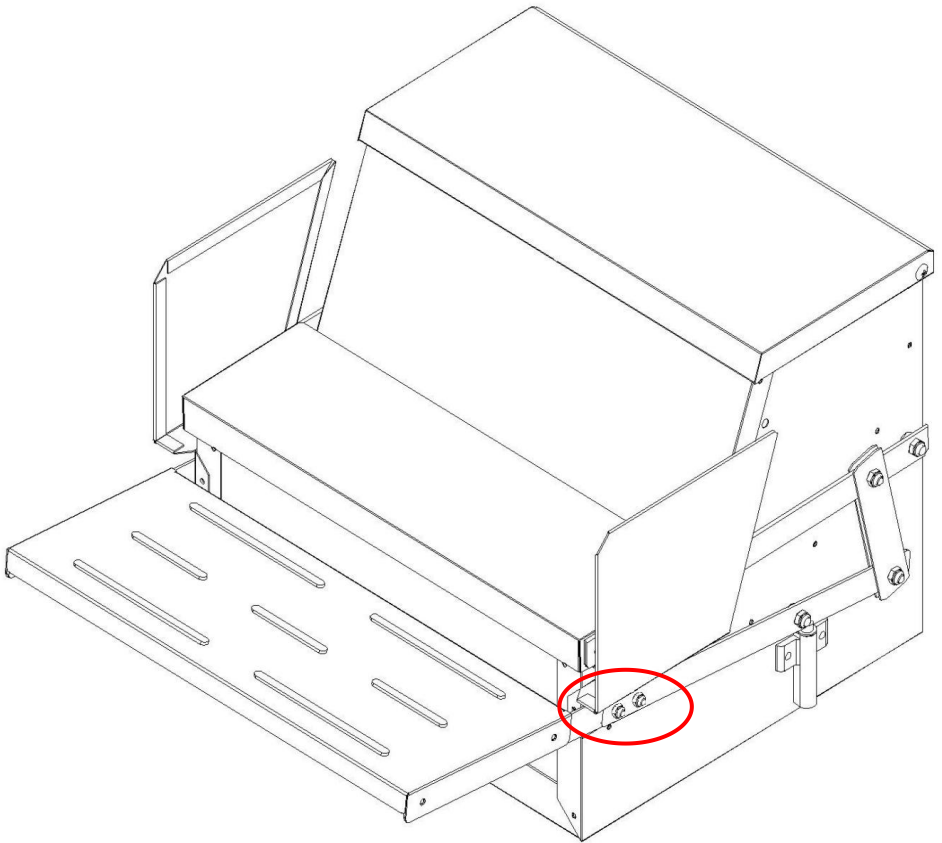

Lock the screws with ②4-M4 nuts.

(The assembly is complete)



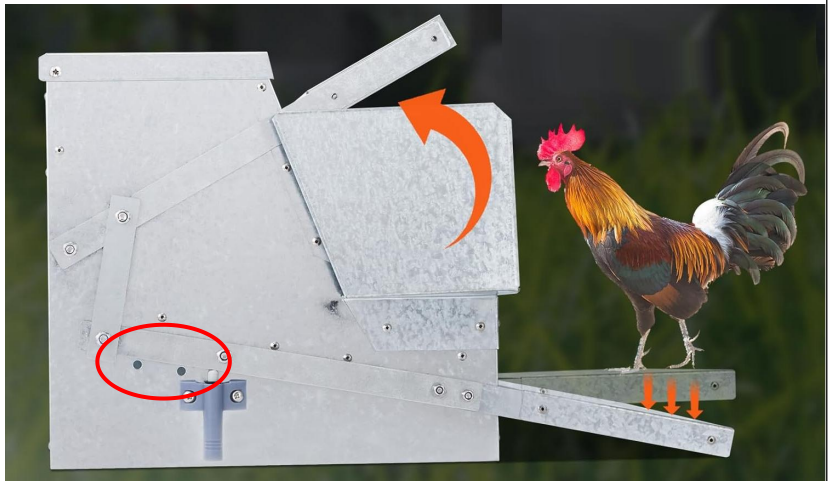

The training hole is not assembled with screws.

Mode A

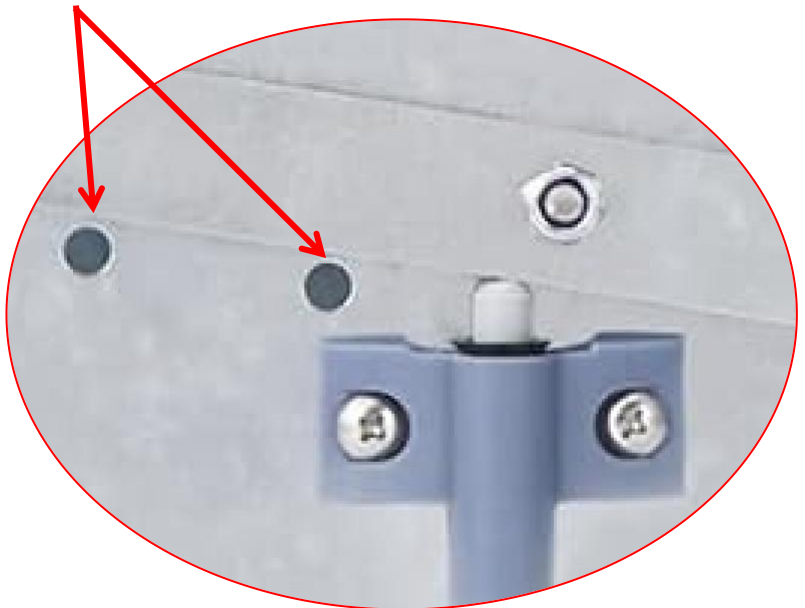

Poultry can pedal to open the lid to get the physical object.

The lid is normally open.



The pedal is in a fixed position.

Mode B

Training hole 1

Training hole 2

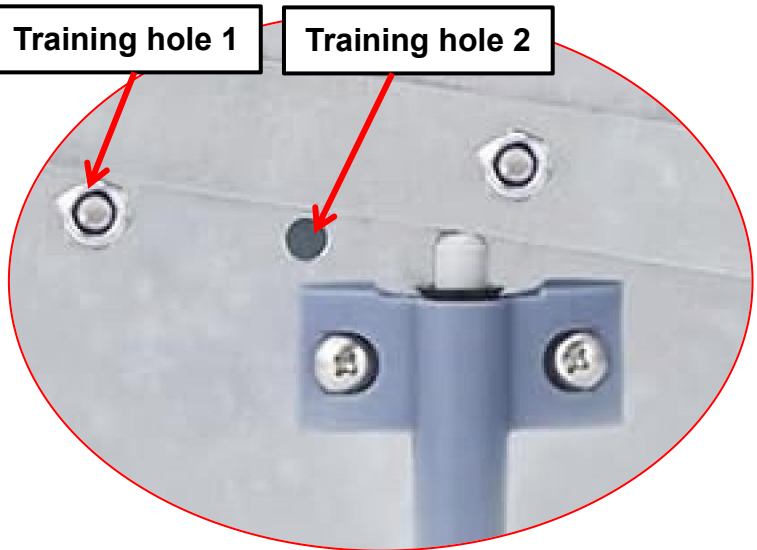

You can lock the training hole 1 or training hole 2 with the ①M6x6 screw and ④M6 nut to hold the pedals and cover in place.

Manufacturer:Shanghaimuxinmuyeyouxiangongsi

Address: Shuangchenglu 803nong11hao1602A-1609shi, baoshanqu, shanghai 200000 CN.

Imported to AUS: SIHAO PTY LTD. 1 ROKEVA STREETEASTWOOD NSW 2122 Australia

Imported to USA: Sanven Technology Ltd. Suite 250, 9166 Anaheim Place, Rancho Cucamonga, CA 91730

| | |
|-----------|------------|
| UK | REP |
|-----------|------------|

E-CrossStu GmbH

Mainzer Landstr.69, 60329 Frankfurt am Main.

| | |
|-----------|------------|
| EC | REP |
|-----------|------------|

YH CONSULTING LIMITED.

C/O YH Consulting Limited Office 147, Centurion House,
London Road, Staines-upon-Thames, Surrey, TW18 4AX

VEVOR[®]

TOUGH TOOLS, HALF PRICE

Technical Support and E-Warranty Certificate

www.vevor.com/support