

VEVOR[®]

TOUGH TOOLS, HALF PRICE

Technical Support and E-Warranty Certificate www.vevor.com/support

LANDSCAPE ROCK RAKE USER MANUAL

We continue to be committed to provide you tools with competitive price.

"Save Half", "Half Price" or any other similar expressions used by us only represents an estimate of savings you might benefit from buying certain tools with us compared to the major top brands and does not necessarily mean to cover all categories of tools offered by us. You are kindly reminded to verify carefully when you are placing an order with us if you are actually saving half in comparison with the top major brands.

VEVOR®

TOUGH TOOLS, HALF PRICE

LANDSCAPE
ROCK RAKE

MODEL: ATVLR60

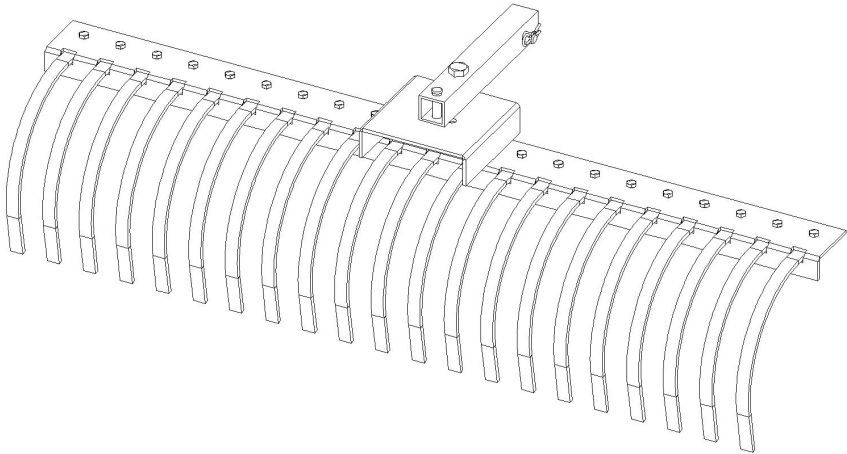

NEED HELP? CONTACT US!

Have product questions? Need technical support? Please feel free to contact us:

Technical Support and E-Warranty Certificate
www.vevor.com/support

This is the original instruction, please read all manual instructions carefully before operating. VEVOR reserves a clear interpretation of our user manual. The appearance of the product shall be subject to the product you received. Please forgive us that we won't inform you again if there are any technology or software updates on our product.



Warning-To reduce the risk of injury, user must read instructions manual carefully.

INSTRUCTIONS

Thank you very much for choosing this product. Please read all of the instructions before using it. The information will help you achieve the best possible results.

PLEASE NOTE! Drawings in this manual are for illustration purposes only and in some details may differ from the actual product.

ATTENTION! Read all safety warnings and all instructions. Failure to follow the warnings and instructions may result in serious injury or even death. The device or product used in the warning instructions is referred to **Tow Behind Dethatcher**.

This product is not a toy or a toy chest. Do not allow children to play with this item. Use as intended only and Need to supervise the children to understand step rules of drag harrow finally.

USAGE SAFETY

1. Select an area for assembly that is clean and free of any debris which might cause persons working on the assembly to trip.
2. Do not lift heavy parts or assemblies. Use crane, jack, tackle, fork trucks or other mechanical devices.
3. Preview the assembly instructions in your operator' s manual before proceeding further.
4. If the assembly instructions call for parts or assemblies to be blocked up, use only block material that is in good condition and is capable of handling the weight of the assembly to be blocked. Also ensure that the blocking material is on a clean, dry surface.
5. Never put hands, or any part of body, under blocked up assemblies if at all possible.

6. After completing assembly, thoroughly inspect the machine to be sure that all nuts, bolts, hydraulic fittings or any other fastener assemblies have been thoroughly tightened.

7. Before operating the machine, thoroughly read the operation section of your operator' s manual.

8. Before operating, read the machine section of your operator' s manual to be sure that any parts requiring lubrication, such as gearbox, to avoid any possible damage.

9. Before operating equipment - if you have any questions regarding the proper assembly or operation, contact you dealer or representative.

EQUIPMENT SAFETY GUIDELINES

1. Never use alcoholic beverages or drugs which can hinder alertness or coordination while operating this equipment. Consult your doctor about operating this machine while taking prescription medications.

2. Review the safety instructions with all users annually.

3. This equipment is dangerous to children and persons unfamiliar with its operation. The operator should be a responsible adult familiar with farm machinery and trained in this equipment's operations. **Do not allow persons to operate or assemble this unit until they have read this manual and have developed a thorough understanding of the safety precautions and of how works.**

4. Never exceed the limits of a piece of machinery.

5. Do not modify the equipment in any way. Unauthorized modification may impair the function and could affect the life of equipment.

OPERATIONAL SAFETY

1. The use of this equipment is subject to certain hazards which cannot be protected against by mechanical means or product design. All operators of this equipment must read and understand this entire manual, paying particular attention to operating, prior to using. If there is something in this manual you do not understand, ask your supervisor, or your dealer, to explain it to you.

2. Personal protection equipment including hard hat, safety glasses, safety shoes, and gloves are recommended during assembly.

3. Never permit any person other than the operator to ride or board the tractor or

implement at any time. **Never allow anyone to ride on the implement!**

4. A heavy load can cause instability in driving a tractor. Make sure the front or rear of the tractor is properly counter-balanced with weights, Always drive slowly-especially around turns. An unstable tractor could steer badly and possibly tip over, causing injury or death.
5. Most accidents occur because of neglect or carelessness. Keep all helpers and bystanders at a safe distance.
6. Use stabilizer bars, adjustable sway chains, or sway blocks on your tractor lift
7. arms to keep the rear blade from swinging side to side. Adjust as tightly as practical for best performance.
8. Do not operate close to ditches or creeks. Slow down when operating over rough ground.
9. When adjusting the angle of the moldboard assembly, be sure that your feet are never under the rear blade.
10. Be careful to avoid catching the rear blade on stumps or other immovable objects.

MAINTENANCE SAFETY

1. Keep all persons away from operator control area while performing adjustments, service, or maintenance.
2. Periodically tighten all bolts, nuts and screws and check that all cotter pins are properly installed to ensure unit is in a safe condition.
3. Never use your hands to locate a hydraulic leak on attachments. Use a small piece of cardboard or wood.
4. Never replace hex bolts with less than grade five bolts unless otherwise specified. Refer to bolt torque chart for head identification marking.

STORAGE SAFETY

1. Store the unit in an area away from human activity. Do not permit children to play on or around the stored unit.
2. Make sure all parked machines are on a hard, level surface and engage all safety devices.
3. If blocking is used, make sure it is solid and secure before leaving area.

SAVE THESE INSTRUCTIONS

TECHNICAL PARAMETERS

Model	ATVLR60
Type	60",steel teeth
Tooth	240*290*24*T7.5mm,quantity of 21
Main material	Q235+65Mn

PARTS LIST

Parts#	Description	Quantity
1	Spring rake	21
2	Bolt M10*25	21
3	Flat washer ϕ 10	21
4	Spring washer ϕ 10	21
5	Lock nut M10	21
6	Plate	1
7	Pin shaft ϕ 16*90	1
8	Spring pin	2
9	Bolt M20*90	1
10	Nut M20	1
11	Pin shaft ϕ 19*90	1
12	Square tube	1

ASSEMBLY

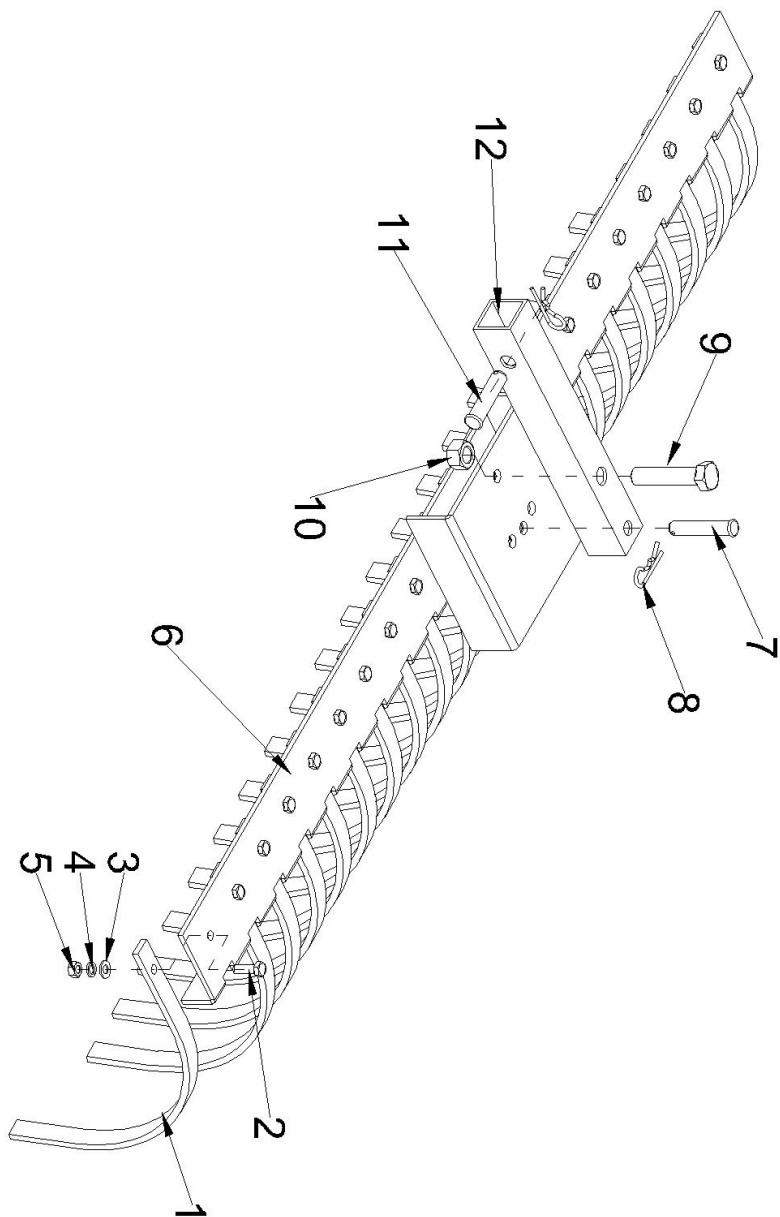

Manufacturer: Shanghaimuxinmuyeyouxiangongsi

Address: Shuangchenglu 803nong11hao1602A-1609shi, baoshanqu,
shanghai 200000 CN.

EC REP: E-CrossStu GmbH.

Mainzer Landstr.69, 60329 Frankfurt am Main.

UK REP: YH CONSULTING LIMITED.

C/O YH Consulting Limited Office 147, Centurion House, London Road,
Staines-upon-Thames, Surrey, TW18 4AX

Imported to AUS: SIHAO PTY LTD.

1 ROKEVA STREETEASTWOOD NSW 2122 Australia

Imported to USA: Sanven Technology Ltd.

Suite 250, 9166 Anaheim Place, Rancho Cucamonga, CA 91730

VEVOR[®]

TOUGH TOOLS, HALF PRICE

Technical Support and E-Warranty Certificate

www.vevor.com/support