

VEVOR[®]

TOUGH TOOLS, HALF PRICE

Technical Support and E-Warranty Certificate

www.vevor.com/support

FISHING CART

MODEL: YK-400

We continue to be committed to provide you tools with competitive price. "Save Half", "Half Price" or any other similar expressions used by us only represents an estimate of savings you might benefit from buying certain tools with us compared to the major top brands and does not necessarily mean to cover all categories of tools offered by us. You are kindly reminded to verify carefully when you are placing an order with us if you are actually saving half in comparison with the top major brands.

VEVOR®

TOUGH TOOLS, HALF PRICE

FISHING CART

MODEL: YK-400



NEED HELP? CONTACT US!

Have product questions? Need technical support? Please feel free to contact us:

Technical Support and E-Warranty Certificate
www.vevor.com/support

This is the original instruction, please read all manual instructions carefully before operating. VEVOR reserves a clear interpretation of our user manual. The appearance of the product shall be subject to the product you received. Please forgive us that we won't inform you again if there are any technology or software updates on our product.

SAFETY INSTRUCTIONS

1. Please check and confirm that the cart is intact and the tire pressure is normal before each use. Please inflate a little before using the wheels, and be careful not to over-inflate! Maximum inflation pressure 2-3psi, the maximum diameter of the wheel after inflation should not exceed 42cm (16.5-inch)!
2. It is forbidden to carry people any condition.
3. It is forbidden to load articles on uneven and hilly terrains.
4. Overload is strictly prohibited.
5. Don't move too fast when passing pothole areas.

MODEL AND PARAMETERS

Model	YK-400
Max. Load	350lbs
Wheels	16inch, inflatable, PU wheels*2
Fishing Rod Barrel	8
Frame Size (inside)	41.5 x 18 x 8inch
Material	Aluminium alloy
Color	White

STRUCTURE DIAGRAM

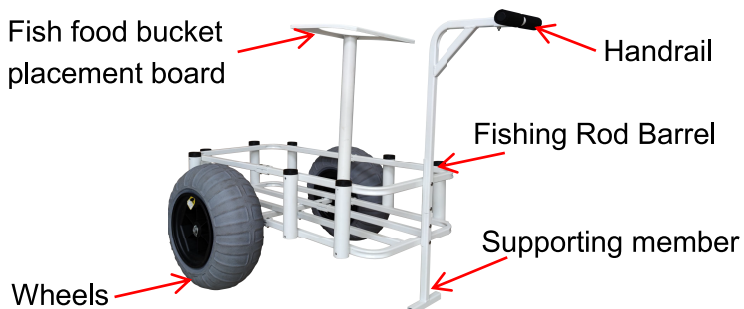

INSTALLATION

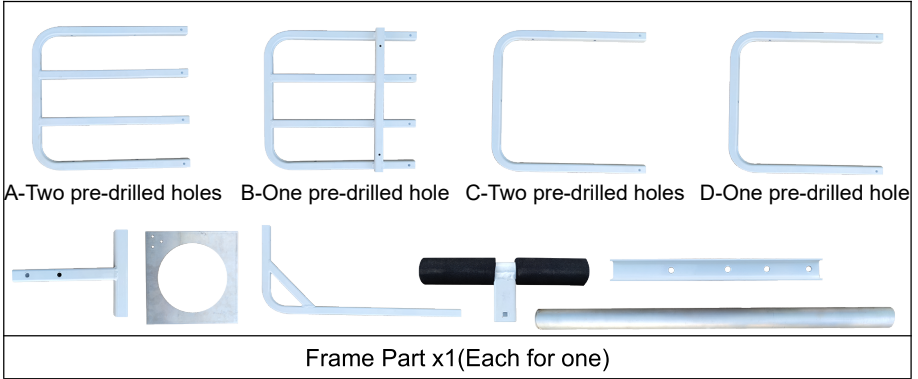

E-Connection Block x12	wheels x2	Washer x2



Axle x2	Linchpin x2	Axle Spacer x2

	 Nut Suitable for fish food tube rods	
Fishing Rod Barrel x7	Fishing Rod Barrel x1 (With nut)	Knob Screw x 1

4mm Hex Wrench x2	3mm Hex Wrench x1	Wrench x1

		
M6x50 Bolts x3 (Need two, one more)	M5x35 Bolts x14 (Need thirteen, one more)	M5x16 Bolts x19 (Need eighteen, one more)

		
M5x60 Bolts x2 (Need one, one more)	M6x20 Bolts x3 (Need two, one more)	Wheel jig cardboard x1

		
Retaining Ring x2	Hand Pump x1	User Manual x1

Step 1: Connect the two lower frames together using the M5x35 bolts and the connection block.

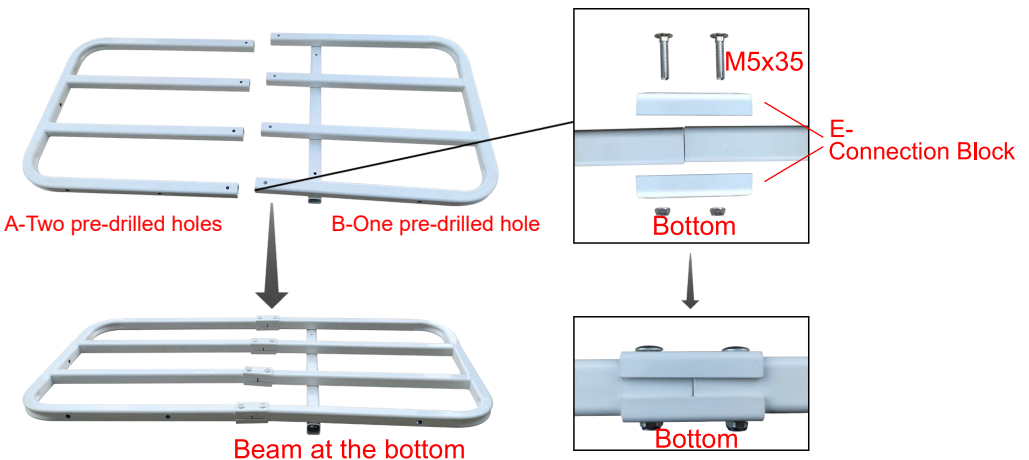

Step 2: Attach the upper frame in the same manner.

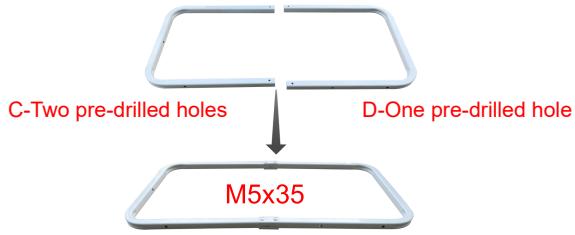

Step 3: Mounting the frame.

NOTE: The frames have pre-drilled holes for mounting the fishing barrels. The number of pre-drilled holes on the upper and lower frames on the same side should be the same.

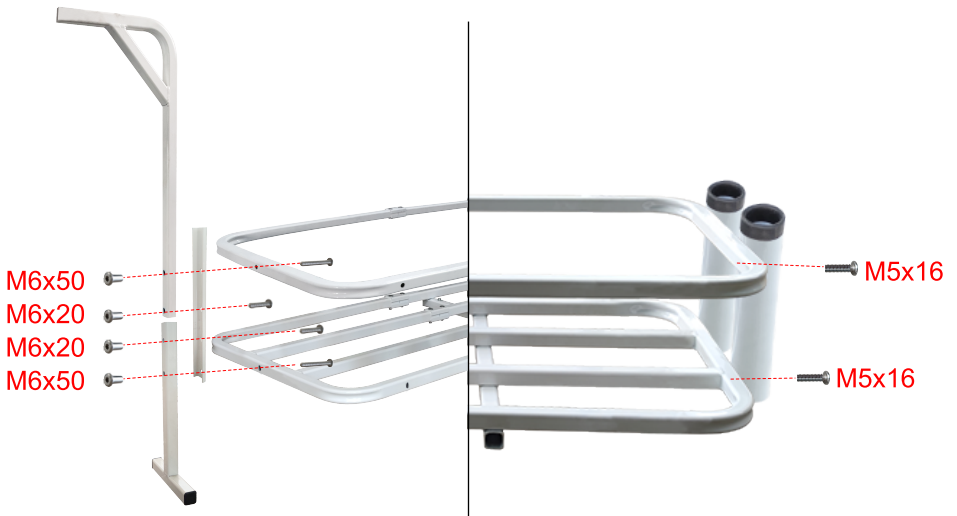
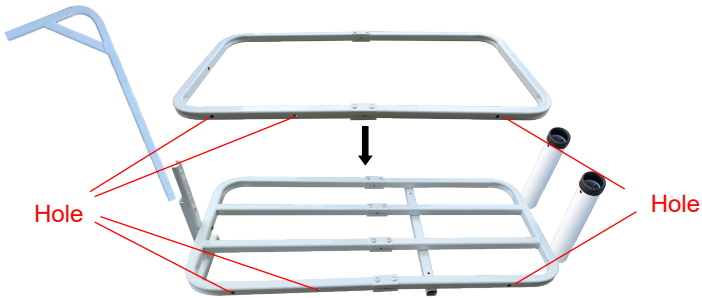



NOTE: M6X60 is required for the bottom bolt of the fishing rod barrel where the fish food bucket is placed.



M5x16



Knob Screw

M5x60



Tip: There is only one bucket with a nut, the upper end uses a Knob Screw and the lower end uses an M5X60 bolt, all other buckets are mounted with an M5X16 bolt.

Step 4: Install all rod barrels, then fix the handrail and the wheels.

NOTE: Please inflate the wheels before installation.



1 Take out the wheel and cardboard jig.



2 Insert the cardboard jig over the top of the wheel.



3 Insert tire valve into top valve of the hand pump. Bend the plastic handle forward to create a seal so that the tire will inflate more quickly.



4 Inflate until the tire fills the circumference of the cardboard jig.

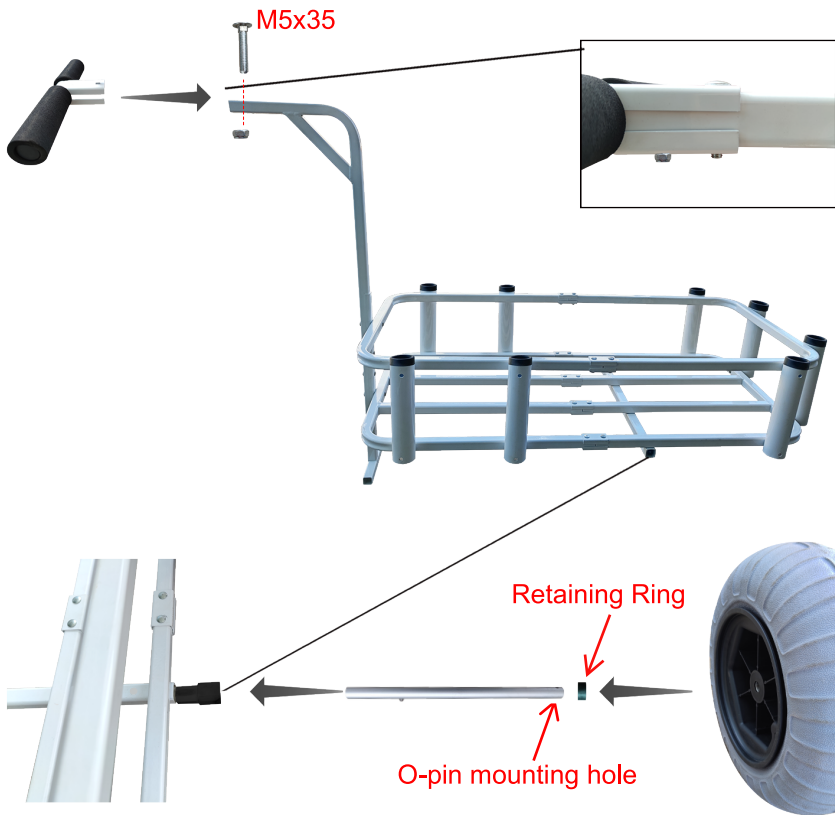

NOTE: Insert the plastic parts of the wheel axle into the ends of the bottom cross member of the frame, then insert the wheel axle, and finally install the wheel on it.

Step 5: Put in the washer first, then insert the O-pin.

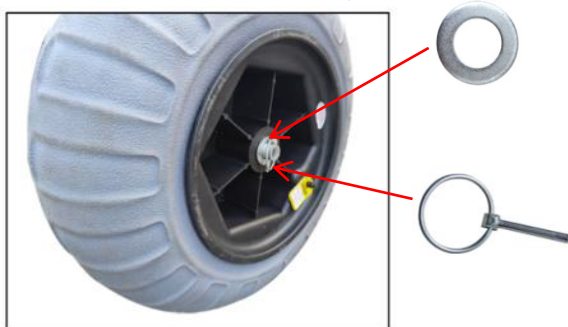

MAINTENANCE

1. Clean the surface after each use.
2. Please check and confirm that the cart is intact and the tire pressure is normal before each use.
3. Check that the bolts are tight.

Manufacturer: Shanghaimuxinmuyeyouxiangongsi

Address: Shuangchenglu 803nong11hao1602A-1609shi, baoshanqu, shanghai 200000 CN.

Imported to AUS: SIHAO PTY LTD, 1 ROKEVA STREET EASTWOOD NSW 2122 Australia

Imported to USA: Sanven Technology Ltd, Suite 250, 9166 Anaheim Place, Rancho Cucamonga, CA 91730

EC	REP
----	-----

E-CrossStu GmbH.
Mainzer Landstr.69, 60329 Frankfurt am Main.

UK	REP
----	-----

YH CONSULTING LIMITED.
C/O YH Consulting Limited Office 147, Centurion House,
London Road, Staines-upon-Thames, Surrey, TW18 4AX

VEVOR[®]

TOUGH TOOLS, HALF PRICE

Technical Support and E-Warranty Certificate

www.vevor.com/support