

VEVOR[®]

TOUGH TOOLS, HALF PRICE

Technical Support and E-Warranty Certificate

www.vevor.com/support

BICYCLE CARGO TRAILER

MODEL: CT901M

We continue to be committed to provide you tools with competitive price.

"Save Half", "Half Price" or any other similar expressions used by us only represents an estimate of savings you might benefit from buying certain tools with us compared to the major top brands and does not necessarily mean to cover all categories of tools offered by us. You are kindly reminded to verify carefully when you are placing an order with us if you are actually saving half in comparison with the top major brands.

VEVOR[®]

TOUGH TOOLS, HALF PRICE

BICYCLE CARGO TRAILER

MODEL: CT901M

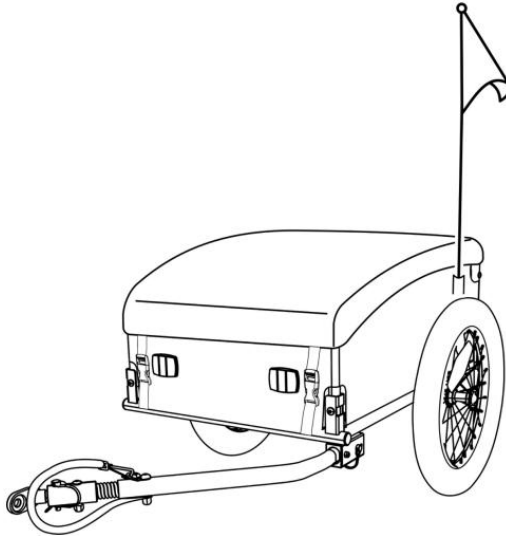

Important: Keep these instructions for future reference

NEED HELP? CONTACT US!

Have product questions? Need technical support? Please feel free to contact us:

Technical Support and E-Warranty Certificate
www.vevor.com/support

This is the original instruction, please read all manual instructions carefully before operating. VEVOR reserves a clear interpretation of our user manual. The appearance of the product shall be subject to the product you received. Please forgive us that we won't inform you again if there are any technology or software updates on our product.

SAFETY INSTRUCTIONS

WARNING

Failure to comply with the instructions and warnings in this manual could result in serious injury or death of the rider.

- The trailer is designed exclusively for transporting cargo on road with a bicycle. It is intended for personal use only. Only use the trailer as described in the instructions. Any other use is considered improper and may result in serious injury or death.
- The bike trailer can be used with any standard adult bicycle. **DO NOT** use the trailer with E-bike or motorcycle.
- **DO NOT** use the trailer to transport child or pet. **DO NOT** use the trailer as a toy.
- **DO NOT** use the trailer off road. **DO NOT** use the trailer without connecting to a bicycle.
- Ensure that all locking devices are engaged before use.
- Maximum load: 45 kg (100 lbs.)
- This product is not suitable for running or skating
- Any load attached to the handle and/or on the back of the backrest and/or on the sides of the vehicle will affect the stability of the vehicle.
- Accessories which are not approved by the manufacturer shall not be used.
- Only use replacement parts supplied or recommended by the manufacturer.
- **DO NOT** use it with a total load that exceeds the weight limits. If recommended load is exceeded, the unit may become unstable.
- **DO NOT** make modifications to the product.
- **DO NOT** over-inflate the tires. Failure to comply with the rated tire sidewall pressure may lead to explosion of the tire and possible injury.
- It is recommended that a qualified bicycle mechanic does a safety check of the towing bicycle before attaching the trailer.
- Before each ride, be sure the trailer does not interfere with braking, pedaling or steering of the bicycle.
- Always comply with local regulations when using the trailer on public roadways.
- Never ride a bicycle at night without adequate lighting.

- Obey all local legal requirements for lighting.
- If you need to come to a stop for any reason, such as to make adjustments or to address a flat tire, be sure to pull off the road completely.
- When using your trailer, you are towing extra weight and a bigger vehicle. You must allow more time for braking, slowing, stopping and starting, and allow more room for turns and passageways. Experiment with the loaded trailer in an uncongested area until you become familiar with how your bike handles towing a trailer.
- Avoid rocks, curbs, hard braking and sudden swerving. Avoid riding over obstacles with one wheel, as this may cause the trailer to tip over.
- Always ride with the cover down to secure the cargo.
- The rider of the bicycle must be at least 16 years old.
- Recommended speed limits: - 16 km/h (10 mph.) on smooth, straight roads - 8 km/h (5 mph.) when turning or on uneven roads .
- Trailer weight must be properly distributed for safe handling. The weight on the hitch connector should be between 30 N (≈ 3 kg / 6.6 lbs.) and 80 N (≈ 8 kg / 17.6 lbs.). To measure this, load your trailer and place it next to bathroom scale. Step on scale and make a note of your weight. Standing on scale, lift up the end of the tow bar one foot (approximately 25cm) off the ground. The weight shown should be 6.6 – 17.6 lbs. more than your own weight. If the weight is too low, the rear wheel of the bicycle could lose traction. If it is too high the hitch may be overloaded.

MODEL AND PARAMETERS

Model	CT901M
Type	Tow
Max. Load	100lbs
Storage Bin Size	26.8*18.5*11.2inch
Wheels	Steel, 16*1.75inch
Material	Steel, Oxford cloth

CONTENTS

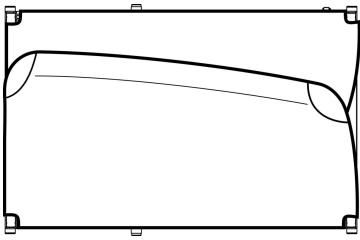

1 x Main frame

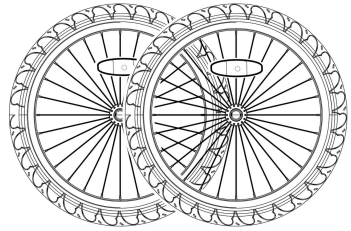

2 x Wheels

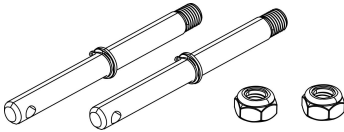

2 x Wheel axle

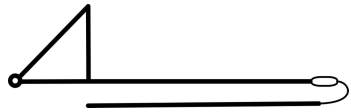

1 x Flag

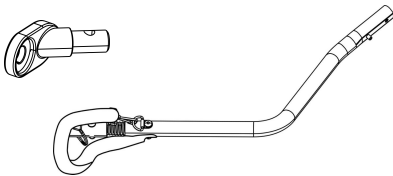

1 x Tow bar

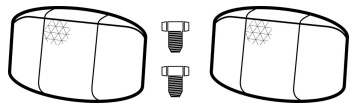

2 x Rear reflectors (**red**)

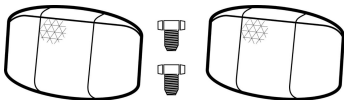

2 x Front reflectors (**white**)

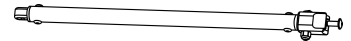

1 x Crossbar

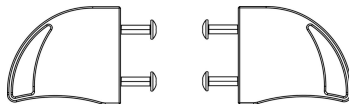

2 x Wheel guards



1 x 19mm Wrench + 1 x 4mm Hex key + 1 x User Manual

How to Assemble

1. Opening the Main Frame

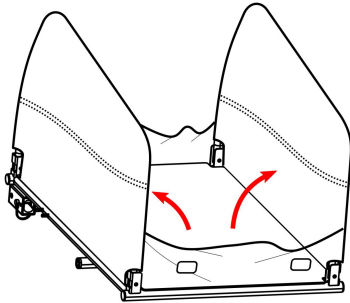

Figure 1

Take out the trailer's main frame and all other components from the carton. Raise both side panels to an upright position (Figure 1).

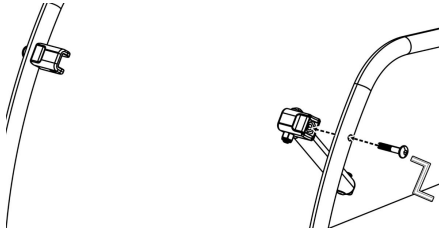

Figure 2

After opening the main frame, install the crossbar on the front of main frame using the hex key (Figure 2).

Fasten the crossbar to the top front part of the main frame. Raise and lock the cross bar using the safety pin attached to the bolt (Figure 3). Make sure that safety pins are properly locked in place as shown (Figure 4).

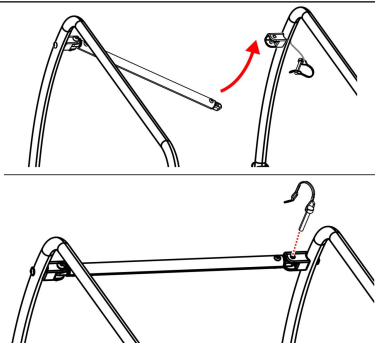

Figure 3

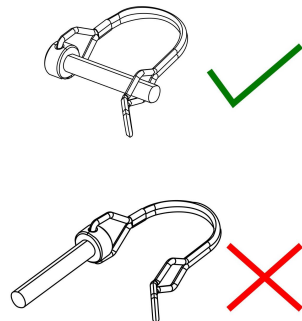

Figure 4

2. Attaching the Wheels

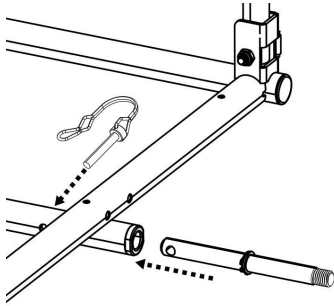

Figure 5

Insert wheel axle into axle receiver underneath the trailer frame and lock the safety pin (Figure 5). Put the wheel and the screw nut on the axle (Figure 6). Fasten the screw nut with 19mm wrench (Figure 7).

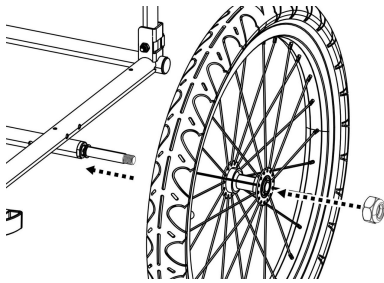

Figure 6

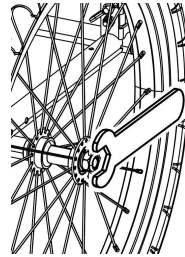

Figure 7

3. Installing the Wheel Guards

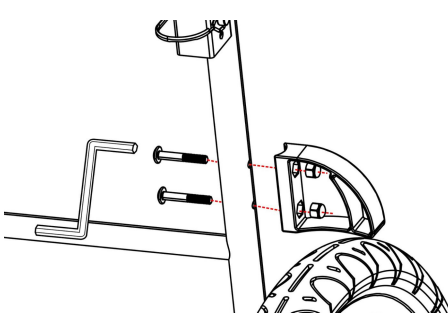
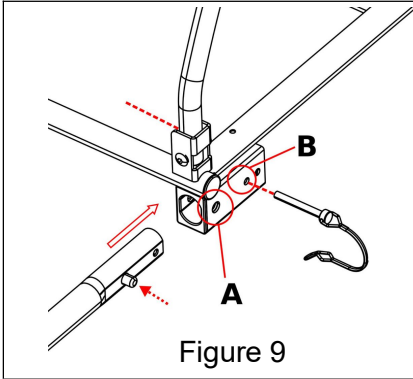

Figure 8

Insert wheel guard bolts through frame tube. Match holes in wheel guards to bolts. Tighten securely with hex key (Figure 8). Repeat for wheel guard on other side of trailer.

4. Installing the Tow Bar



Pressing the spring button, slide the tow bar into the tow bar receiver until the spring button comes out of the hole A. Insert the safety pin from the hole B through the other side. Make sure the safety pin is properly locked in place as shown (Figure 9)

5. Attaching the Cover and Flag

Pull out and fix the cloth with buckle. Tighten the strap to fasten the cloth (Figure 10). Attach hook-and-loop fastener to corresponding position. Insert the flag pole into the flagpole pocket at the left rear corner of the side panel (Figure 11).

You can roll up and pack the cloth when not using it (Figure 11).

Insert screws into holes on the cover to fasten front (white) and rear (red) reflectors. (Figure 10,11)

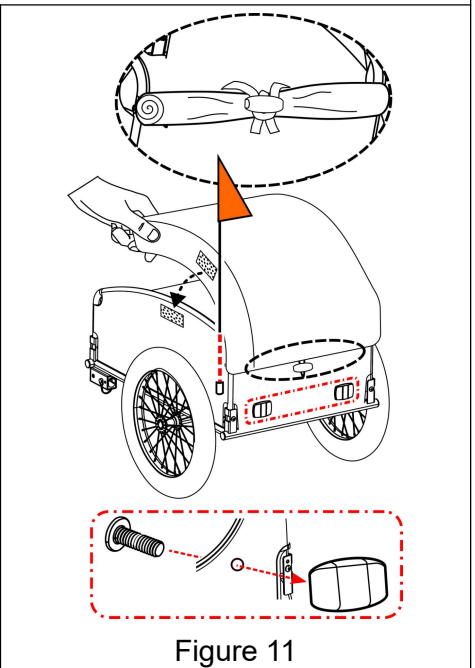
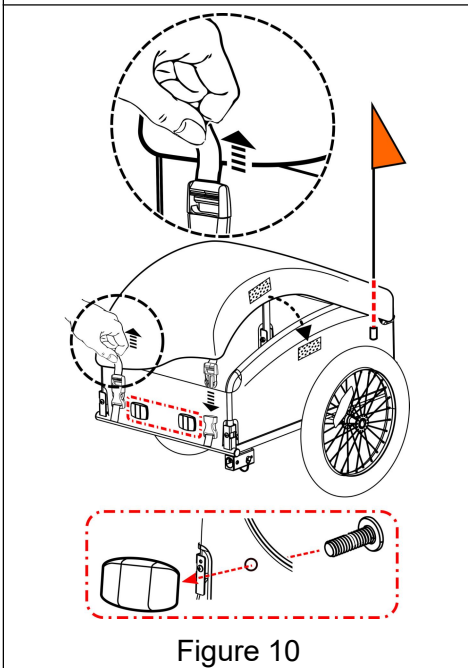

6. Attaching Trailer to Bicycle

1. Quick-release Axle: Remove the quick-release from the left side of bike's rear axle. Install the hitch between the quick-release and frame. Tighten the quick-release following the bike manufacturer's manual. Hitch can remain on the bike when the trailer is removed (Figure 12).

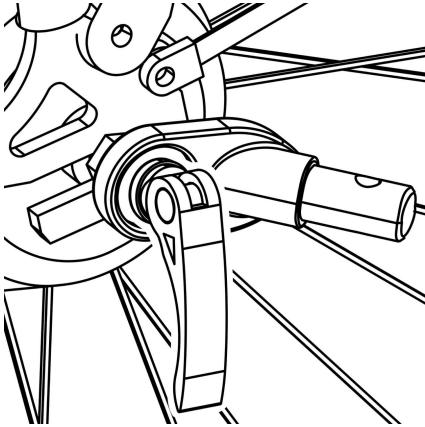

Figure 12

⚠ WARNING

The tension-adjusting nut must engage the threads for at least five full turns in order to ensure adequate clamping force for holding the rear wheel securely. Failure to tighten the tension-adjusting nut fully may result in accidents with serious injury or death. If the quick-release skewer is too short, it must be replaced. Consult a professional bicycle mechanic for the appropriate parts and assistance.

2. Nutted Axle: Unscrew the nut with washer from the left side of bike's rear axle. Install the hitch onto the axle and screw the nut back on with the washer(Figure 13).

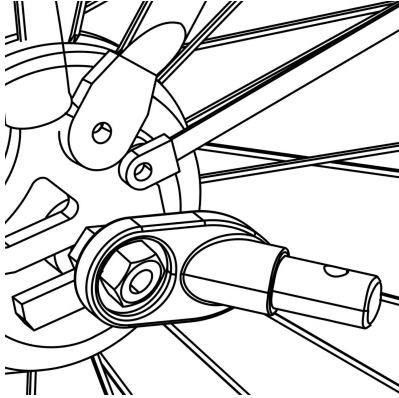

Figure 13

⚠ WARNING

The axle nut must engage the threads for at least five full turns in order to ensure adequate clamping force for holding the rear wheel securely. Failure to tighten the nut fully may result in accidents with serious injury or death. If the axle is too short, the Universal Hitch cannot be used! Consult a professional bicycle mechanic for the appropriate parts and assistance.

3. Thru Axle: The universal hitch doesn't fit a bike with thru axle. Please consult the retailer for possible solution.

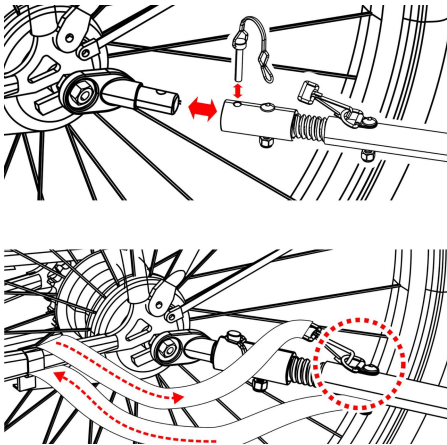

Figure 14

Connect the coupler on the tow bar and secure the safety pin (Figure 14). Once the tow bar is attached, wrap safety belt around the frame of the bike and hook onto the D-ring on the tow bar.

Before You Ride

Check before each use:

1. Wheels are properly secured to the trailer .
2. Tires are inflated to recommended pressure on the tire side wall .
3. Tow bar is properly secured to the trailer .
4. Coupler is properly secured to the bicycle .
5. Coupler and tow bar safety pins are secured .
6. Safety strap on the tow bar is properly installed .
7. Load does not exceed 30kg (66 lbs.).
8. Weight of tow bar at coupler is greater than 3 kg but does not exceed 8 kg (6.6 – 17.6 lbs.) with fully loaded trailer .
9. Make sure that bicycle is in proper working order, especially brakes and tires .(refer to bicycle manufacturer’s instructions)
10. Rider is wearing a helmet .
11. Safety flag is in place .
12. Cargo is properly secured with harness and lap belt .
13. Cover is installed and closed .

MAINTENANCE

Storage: For longer product life, store trailer indoors. The trailer should not be stored at temperatures less than -10°F (-23°C) or greater than 150°F (65°C).

Fabric Care: Hand wash fabric parts with warm water and mild soap. DO NOT use bleach or solvents. Wipe dry and store out of direct sunlight in a dry, well-ventilated area. Clean windows with a damp, soft cloth.

Check:

- Inspect tow bar, hitch, frame tubing, flex connector and hardware for damage .
- Flex Connectors need to be serviced every 3-5 years for safe operation - Check that bolts are tight .
- Inspect tires and wheels for wear and cracks - Inspect wheels for trueness and cracks .
- Inspect fabric parts for rips, abrasions, and missing or damaged hardware.

Manufacturer: Shanghai muxinmuyeyouxiangongsi

Address: Shuangchenglu 803nong11hao1602A-1609shi, baoshanqu, shanghai 200000 CN.

EC REP: E-CrossStu GmbH

Mainzer Landstr.69, 60329 Frankfurt am Main.

UK REP: YH CONSULTING LIMITED.

C/O YH Consulting Limited Office 147, Centurion House, London Road, Staines-upon-Thames, Surrey, TW18 4AX

Imported to AUS: SIHAO PTY LTD.

1 ROKEVA STREET EASTWOOD NSW 2122 Australia

Imported to USA: Sanven Technology Ltd.

Suite 250, 9166 Anaheim Place, Rancho Cucamonga, CA 91730

VEVOR[®]

TOUGH TOOLS, HALF PRICE

Technical Support and E-Warranty Certificate

www.vevor.com/support