

VEVOR[®]

TOUGH TOOLS, HALF PRICE

Technical Support and E-Warranty Certificate

www.vevor.com/support

PRESSURE PAINT POT USER MANUAL

We continue to be committed to provide you tools with competitive price. "Save Half", "Half Price" or any other similar expressions used by us only represents an estimate of savings you might benefit from buying certain tools with us compared to the major top brands and does not necessarily mean to cover all categories of tools offered by us. You are kindly reminded to verify carefully when you are placing an order with us if you are actually Saving Half in comparison with the top major brands.

VEVOR[®]

TOUGH TOOLS, HALF PRICE

PRESSURE PAINT POT

MODEL: JY-SS15L



Photo for reference

NEED HELP? CONTACT US!

Have product questions? Need technical support? Please feel free to contact us:

Technical Support and E-Warranty Certificate
www.vevor.com/support

This is the original instruction, please read all manual instructions carefully before operating. VEVOR reserves a clear interpretation of our user manual. The appearance of the product shall be subject to the product you received. Please forgive us that we won't inform you again if there are any technology or software updates on our product.

SAFETY INSTRUCTION AND PRECAUTIONS

⚠️WARNING:

Read this material before using this product. Failure to do so can result in serious injury.

- 1.Assemble only according to these instructions. Improper assembly can create hazards.
- 2.Wear ANSI-approved safety goggles and heavy-duty work gloves during assembly.
- 3.Keep assembly area clean and well lit.
- 4.Keep bystanders out of the area during assembly.
- 5.Do not assemble when tired or when under the influence of alcohol, drugs or medication.
- 6.Product capabilities apply to properly and completely assembled product only.
- 7.Assemble on a flat, level, hard and smooth surface capable of safely supporting a fully loaded Pressure Paint Pot.

⚠️WARNING:

1. This product is not a toy. Do not allow children to play with or near this item. Children or persons with physical disabilities are prohibited from using this product, and people who do not know how to use it safely are prohibited from operating this product
2. This product 15L allows the paint to be pressurized to 60PSI, and the maximum operating pressure must not exceed 70PSI, otherwise it will cause the risk of personal safety.
3. The safety valve on the pressure barrel is used to protect the normal pressure in the pressure barrel, avoid over pressure of a safety device, before the product leaves the factory has been set within the allowable pressure range, in the normal state of use, do not remove at will, do not adjust at will.

4. This product should not perform any form of modification, nor engage in any dangerous operations such as drilling, welding, etc., which may produce a tempering effect, damaging the pressure barrel, which affects the service life of the product.
5. It is strictly forbidden to pour strong acidic and alkaline liquid into this product to avoid corrosion of the tank body and causing personal injury.
6. Use as intended only.
7. Inspect before every use; do not use if parts are loose or damaged.
8. After spraying with this product, it must be thoroughly cleaned to extend the service life of the product.

Preface

This Pressure Paint Pot is composed of inlet balloon valve switch, air pressure regulating valve, safety valve and discharge port. All parts are made of the best materials, and have passed strict quality control, and the appearance is treated with baking paint, so it can achieve the purpose of durability.

Schematic diagram of JY-SS15L decomposition

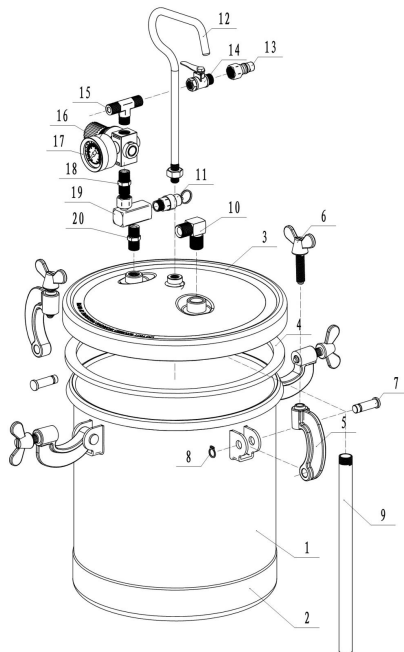

SN	name	quantity
1	Pressure barrel body	1
2	Pressure drum base	1
3	Barrel lid	1
4	Sealing rings	1
5	G-type fastening bolts	4
6	M10 butterfly nut	4
7	Fixed pins	4
8	Circlips	4
9	Suction tube	1
10	Outlet	1
11	relief valve	1
12	handle	1
13	1/4" self-locking quick plug tubing fitting	1
14	Inlet balloon valve switch	1

15	Air outlet	1
16	Intake regulator	1
17	Pressure gauge	1
18	Connection header	1
19	Tee connector	1
20	Connection header	1

List of user thread specifications:

SN	SKU name	valve	Thread specifications
1	North American Standards	Air intakes	American style 1/4"self-locking quick plug tubing fitting
		Air outlet (including opening and closing valve)	American 1/4",threaded NPS,18teeth
		Discharge port (with opening and closing valve)	American 3/8",threaded NPS,18teeth
2	European standard	Air intakes	European style 1/4" self-locking quick plug tubing fitting
		Air outlet (including opening and closing valve)	European 1/4",thread G, 19teeth
		Discharge port (with opening and closing valve)	European 3/8",thread G,19teeth
3	Australian standard	Air intakes	Japanese style 1/4" self-locking quick plug tubing fitting
		Air outlet (including opening and closing valve)	European 1/4",thread G, 19teeth
		Discharge port (with opening and closing valve)	European 3/8",thread G, 19teeth

How to use

Before use, please make sure that there can be no residual pressure in the pressure barrel, if there is residual pressure, the operator can pull open the Red Hat safety valve bleed pull ring on the pressure barrel lid to completely release the air pressure inside the pressure barrel to ensure safety.

1. After loosening the butterfly bolt, open the pressure barrel lid
2. Pour in the spray material.
3. Close the pressure barrel lid and tighten the butterfly bolts one by one in a diagonal manner. Install the intake regulator on the three-way connector.



4. Close all valves, the sprayer inlet is connected to the barrel outlet (10), and the sprayer inlet is connected to the barrel outlet valve (15).



5. Connect the air intake connector (13) and open the air intake valve (14).

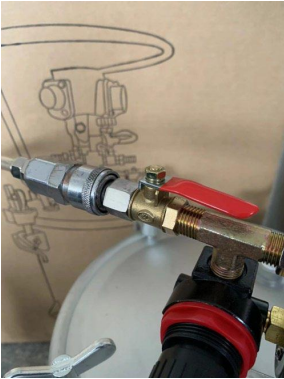

6. Adjust the intake pressure regulator, rotate clockwise to adjust to the required working pressure, if you want to reduce the pressure in the pressure barrel, rotate in a counterclockwise direction.



Maintenance

1. After use, cut off the air source. Open the balloon valve switch on the lid to completely release the air in the barrel, then loosen the butterfly bolt, open the lid of the barrel, pour out the residual paint in the barrel, and clean all parts that have been touched by the paint with an appropriate amount of solvent.
2. Pour the cleaning solvent into the bucket, close the lid to lock it, open the intake valve, and operate the sprayer until the clean solvent appears.
3. Safety valves must be kept clean at all times.

Air leakage remedy

Note: If you find air leakage during use, please apply the glue evenly along here, and then close the lid of the barrel; tighten the screws while the pressure reaches 15PSI; The time is about 10 seconds, so that the glue completely penetrates the leakage, close the intake valve, open the pressure relief plunger, and stand still for 6-8 hours before continuing to use the glue after it is completely solidified.

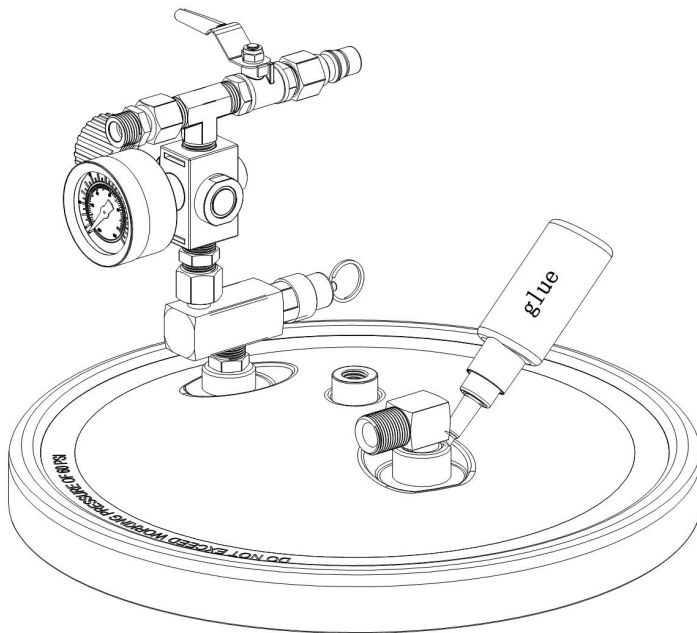

Troubleshooting

Fault	The cause of the failure	Exclusion method
The pointer of the pressure gauge connected to the air supply does not move	<ol style="list-style-type: none"><li data-bbox="351 1321 665 1347">1. The air source is not normal<li data-bbox="351 1362 665 1388">2. The intake valve is not open<li data-bbox="351 1404 665 1430">3. Other valves are not closed	<ol style="list-style-type: none"><li data-bbox="743 1299 1009 1362">1. Adjust the air source to normal<li data-bbox="743 1378 994 1404">2. Open the intake valve<li data-bbox="743 1420 956 1445">3. Close other valves

Paint barrel lid leakage	<ol style="list-style-type: none"> 1. When the barrel lid is combined with the barrel body, the butterfly nut is not tightened diagonally 2. The parts on the barrel lid are poorly sealed 	<ol style="list-style-type: none"> 1. Follow Article 3 of the Terms of Use 2. Refer to the remedy for air leakage
No paint	<ol style="list-style-type: none"> 1. The discharge valve is not open 	<ol style="list-style-type: none"> 1. Open the discharge valve
Poor paint effect	<ol style="list-style-type: none"> 1. The pressure is too high or too low 2. Spraying equipment problems 	<ol style="list-style-type: none"> 1. Adjust to normal pressure 2. Repair of spraying equipment

Make sure to lock the bucket lid diagonally order of operations; 1-2 3-4

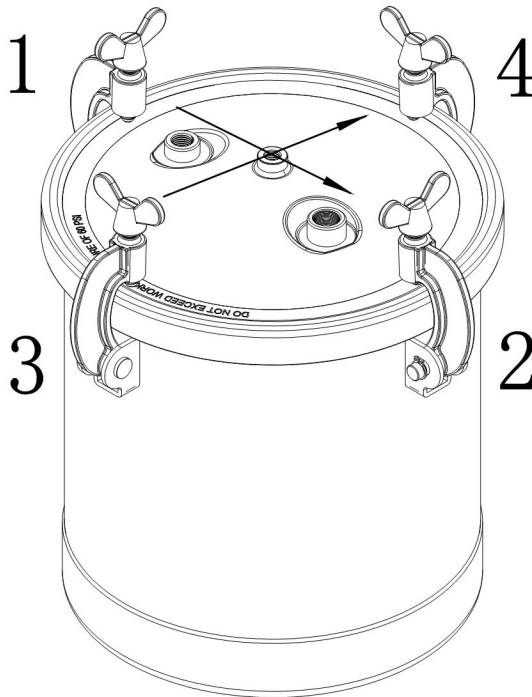

Address: Shuangchenglu 803nong11hao1602A-1609shi, baoshanqu, shanghai 200000 CN.

Imported to AUS: SIHAO PTY LTD, 1 ROKEVA STREETEASTWOOD NSW 2122 Australia

Imported to USA: Sanven Technology Ltd., Suite 250, 9166 Anaheim Place, Rancho Cucamonga, CA 91730

EC	REP
-----------	------------

E-CrossStu GmbH
Mainzer Landstr.69, 60329 Frankfurt am Main.

UK	REP
-----------	------------

YH CONSULTING LIMITED.
C/O YH Consulting Limited Office 147, Centurion House,
London Road, Staines-upon-Thames, Surrey, TW18 4AX

VEVOR[®]

TOUGH TOOLS, HALF PRICE

Technical Support and E-Warranty Certificate

www.vevor.com/support