

# **VEVOR<sup>®</sup>**

**TOUGH TOOLS, HALF PRICE**

**Technical Support and E-Warranty Certificate**

**[www.vevor.com/support](http://www.vevor.com/support)**

## **NUT RIVETER 16 INCH**

We continue to be committed to provide you tools with competitive price.

"Save Half", "Half Price" or any other similar expressions used by us only represents an estimate of savings you might benefit from buying certain tools with us compared to the major top brands and does not necessarily mean to cover all categories of tools offered by us. You are kindly reminded to verify carefully when you are placing an order with us if you are actually saving half in comparison with the top major brands.

# VEVOR<sup>®</sup>

TOUGH TOOLS, HALF PRICE

## NUT RIVETER 16 INCH

MODEL: DY-8804

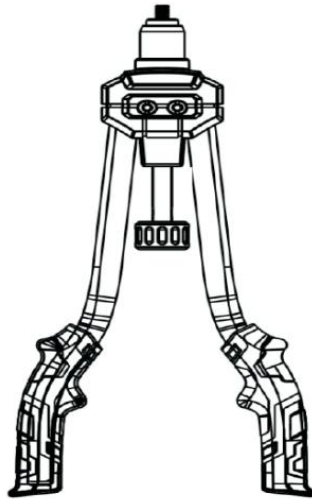



### NEED HELP? CONTACT US!

Have product questions? Need technical support? Please feel free to contact us:

**Technical Support and E-Warranty Certificate**  
[www.vevor.com/support](http://www.vevor.com/support)

This is the original instruction, please read all manual instructions carefully before operating. VEVOR reserves a clear interpretation of our user manual. The appearance of the product shall be subject to the product you received. Please forgive us that we won't inform you again if there are any technology or software updates on our product.

	<p>Warning-To reduce the risk of injury, user must read instructions manual carefully.</p>
	<p>Warning- Be sure to wear eye protectors when using this product.</p>

## INTENDED USE OF THE TOOL

This tool is intended to be used to install metric M4, M5, M6, M8, M10, M12 and SAE 10-24, 1/4-20, 5/16-18, 3/8-16, 1/2-13 rivet nuts. Do not use this tool outside of the designed intent. Never modify the tool for any other purpose or use.

## SAFETY PRECAUTION

**Caution: To help prevent personal injury.**

- Normal use of this product is likely to expose the user to dust and/or microscopic particles containing chemicals that cause cancer, birth defects or other reproductive harm. Always wear appropriate safety equipment and clothing when using this product. Study, understand and follow all instructions provided with this product.
- Always wear CERTIFIED GOOGLES when using this product. (Users and By standers)
- Always select the correct accessories of the correct size and design for the job that you are attempting to perform.
- Never use this tool for any application other than for which it was designed.
- Only use accessories designed for this tool.
- Never alter or modify this tool in any way.

## SET INCLUDES

16 in hand riveter

Interchangeable threaded mandrels & nosepieces:

M3,M4,10-24,M5,M6,1/4-20,8-32,5/16-18,M8,3/8-16,M10,M12,1/2-13,1pc

Steel rivet nuts: M3,M4,10-24,M5,M6,1/4-20, 20pc

8-32,5/16-18,M8,3/8-16,M10,M12 ,10pc

1/2-13 ,6pc

# HOLE SIZE GUIDE

METRIC		SAE	
Nut Size	Hole Size	Nut Size	Hole Size
M3	5mm (3/16")	8-32	7mm (9/32")
M4	6mm (1/4")	10-24	7mm (9/32")
M5	7mm (9/32")	1/4-20	9mm (23/64")
M6	9mm (3/8")	5/16-18	11mm (7/16")
M8	11mm (7/16")	3/8-16	13mm (33/64")
M10	13mm (17/32")	1/2-13	17.5mm (11/16")
M12	15mm (3/5")		

## OPERATION INSTRUCTIONS

1. Choose the rivet nut size to be installed.
2. Install the correct size mandrel/nosepiece for the rivet nut to be installed. See photos and instructions for changing the mandrel/nosepiece.
3. Drill a hole in the workpiece the same size or slightly larger than the outside diameter of the rivet nut to be installed, ref to the section of "HOLE SIZE GUIDE".
4. To install the rivet nut, open the handles outward as far as possible and thread the rivet nut clockwise onto the mandrel until reaching the nosepiece.
5. Insert the rivet nut fastened to the riveter into the pre-drilled hole until flush with the workpiece, squeeze two handles to touch the workpiece and secure the rivet nut into the hole. Open the handles outward to unscrew the threaded mandrel from the gripped rivet nut completely.

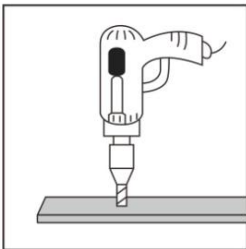

**1** Drill with a pistol and drill first.

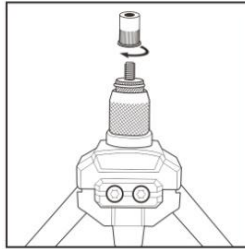

**2** Insert a rivet nut into the nosepiece.

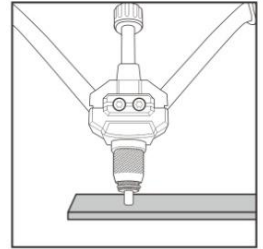

**3** Insert the rivet nut into the hole.

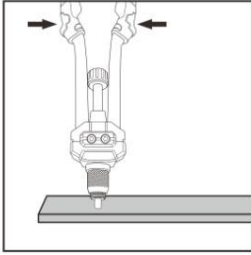

**4** Squeeze the handle.

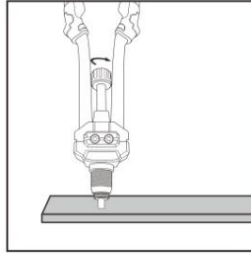

**5** Unscrew the threaded mandrel from the gripped rivet nut completely

## HOW TO CHANGE THREADED MANDREL AND NOSEPIECE

1. Remove and install the mandrel and nose pieces. Always keep the matched mandrel/nosepiece sets together.
2. Remove nosepiece from sleeve nut by unthreading the nosepiece anticlockwise. (see Fig. 1)
3. Remove sleeve nut by unthreading anticlockwise. (see Fig. 2)
4. Take out the mandrel directly to remove it from the head. (see Fig. 3)
5. Choose the correct mandrel/nosepiece to be installed.
6. Thread the new mandrel into the tool.
7. Install the sleeve nut and nosepiece.

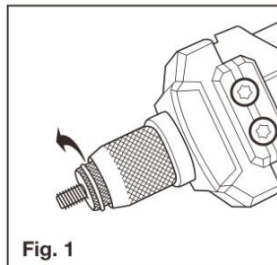

**Fig. 1**

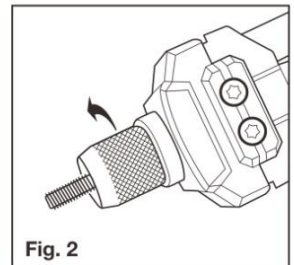

**Fig. 2**

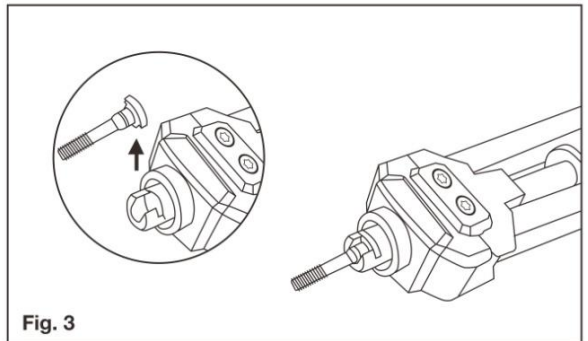

**Fig. 3**



Note Store matching nosepieces and mandrels together when not in use to prevent mismatching the sizes and for convenience.

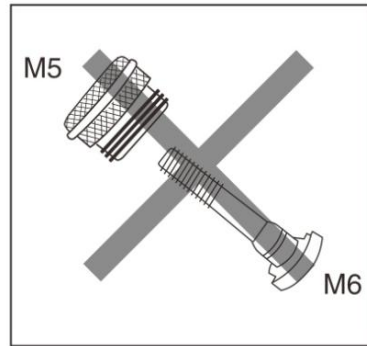
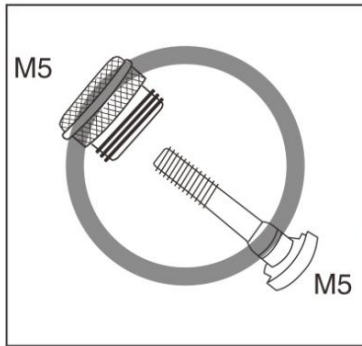

**Manufacturer:** Shanghaimuxinmuyeyouxiangongsi

**Address:** Shuangchenglu 803nong11hao1602A-1609shi, baoshanqu, shanghai 200000 CN.

**Imported to AUS:** SIHAO PTY LTD. 1 ROKEVA STREET EASTWOOD NSW 2122 Australia

**Imported to USA:** Sanven Technology Ltd. Suite 250, 9166 Anaheim Place, Rancho Cucamonga, CA 91730

<b>UK</b>	<b>REP</b>
-----------	------------

YH CONSULTING LIMITED. C/O YH Consulting Limited Office 147, Centurion House, London Road, Staines-upon-Thames, Surrey, TW18 4AX

<b>EC</b>	<b>REP</b>
-----------	------------

E-CrossStu GmbH  
Mainzer Landstr.69,  
60329 Frankfurt am Main.



**VEVOR<sup>®</sup>**

**TOUGH TOOLS, HALF PRICE**

**Technical Support and E-Warranty Certificate**

**[www.vevor.com/support](http://www.vevor.com/support)**