

# **VEVOR<sup>®</sup>**

## **TOUGH TOOLS, HALF PRICE**

Technical Support and E-Warranty Certificate [www.vevor.com/support](http://www.vevor.com/support)

# **WORM BIN**

## **USER MANUAL**

We continue to be committed to provide you tools with competitive price.

"Save Half", "Half Price" or any other similar expressions used by us only represents an estimate of savings you might benefit from buying certain tools with us compared to the major top brands and does not necessarily mean to cover all categories of tools offered by us. You are kindly reminded to verify carefully when you are placing an order with us if you are actually saving half in comparison with the top major brands.

# VEVOR<sup>®</sup>

TOUGH TOOLS, HALF PRICE

## WORM BIN

WB25101



### NEED HELP? CONTACT US!

Have product questions? Need technical support? Please feel free to contact us:

**Technical Support and E-Warranty Certificate**  
[www.vevor.com/support](http://www.vevor.com/support)

This is the original instruction, please read all manual instructions carefully before operating. VEVOR reserves a clear interpretation of our user manual. The appearance of the product shall be subject to the product you received. Please forgive us that we won't inform you again if there are any technology or software updates on our product.

# **Safety precautions**

**WARNING:** Please pay close attention to the following instructions to reduce the risk of injuries, accidents or damage to the product by itself.

- 1. Please follow ALL safety instructions listed below.**
- 2. Please remove the packaging material before assembling or using the product.**
- 3. Please make sure that all listed parts are included in the package and that they are not damaged.**
- 4. Please read these assembly and safety instructions carefully before usage of the BIN and keep it for future reference.**
- 5. This product should only be used in a non-commercial way.**
- 6. Do not use or store this item in the proximity of open flame or flammable/combustible chemicals.**

**Warning - please keep plastic and small spare parts out of children's reach. The thin film may cling to nose and mouth and prevent breathing.**

**SAVE THESE INSTRUCTIONS**

## Part List:

Name	Part	Quantity
Lid		1
Working Tray		5
Base		1
Worm-saver Tray(M-board)		1
Ant Trap		4

Spigot		1
Cup		1
Spade		1
Rake		1
Coconut coir mat		1
Coconut coir brick		1
User Manual		1

# Assembly



1) Locate the Spigot from the worm bin which comes with two pieces of plastic washers and one piece of plastic nut;



2) Place one piece of the plastic washers inside the recess in front of the Base, then, insert the Spigot through the hole;



3) Insert the other piece of plastic washer through the threaded part from the inside of the Base, and then, screw the plastic nut onto the thread, and hand -tighten the nut;(Caution! Make sure the plastic nut is tightened enough to prevent leakage);



4) Place the Worm-saver Tray (M-board) on top of the Base;



5) Place the Working Tray on top of the Worm-saver Tray(M-board);



6) Place the Lid on top of the Working Tray.



7) When ants present, place Ant-trap (4 pieces) on to the bottom corners of the Base and pour water into the Ant-traps.

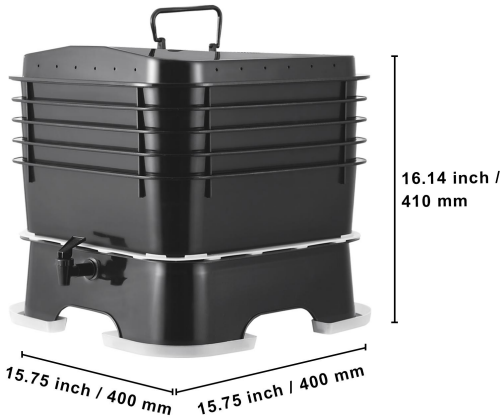

Empty and partially loaded status



Full load condition



# **Set-up and Start-Up**

---

## **Worm Bedding Materials**

Worm bedding is the place where worms live and work.

Worms need to have a comfortable living environment to efficiently work on composting. The choice of material is essential in creating healthy bedding for your worms.

Followings are the recommended materials for the worm bedding:

Damp coconut fiber, worm castings, soil (not clay), shredded newspaper, shredded paper, crushed eggshells, decayed backyard leaves Or grasses (avoid using green leaves or grasses because they will generate heat during composting and increase the temperature inside the worm bin) .

## **Worm Bedding Set-up**

1. Find a bucket from your home (over one-gallon size), and fill it with one gallon of water. Soak the coconut coir in the water until it breaks apart and is moist.

2. After the coconut coir is soaked and moist, locate one of the working trays, and scoop the soaked coconut coir from the bucket to the working tray. Mix the soaked coconut coir with a few handfuls of soil (not clay), shredded paper or other garden compost. Now, you have the coconut coir/soil mixture, which is the worm bedding.

It is important to ensure the bedding material above is moist, not wet or dry. To test the moisture of the bedding, simply place a small handful of the mixture on your hand. If water drips out from the bedding without squeezing, it indicates the bedding is too wet. However, if no water drips when you squeeze the bedding, it tells you the moisture is too dry. If it is too wet, mix it with some shredded dry paper to dry it up; if it is too dry, sprinkle some water on the bedding.

3. Next, take another working tray and cover the bottom of this working tray with 2 or 3 sheets of dry newspaper.

4. Spread the bedding materials prepared at Step 2 on top of the dry newspaper.

Then,place this working tray (it is called the first working tray) on top of the white plastic board(worm-saving tray or M-Board) ,and cover it up with the lid. Now,you have a perfect worm farm waiting for the arrival of your worms. Clean the working tray used for preparing the bedding,and set aside the empty working trays for future use.

### **Worm Food**

The following can be served as worm foods:vegetables craps,fruit (of low acidity) ,eggshells,shredded paper,cardboard,coffee ground and filters,grains,starches,decayed garden leaves and grasses,manure of horse and cow,wood sawdust,and hair.

Note: Animal waste can be used as worm food. However, remember that all animals get wormed and this could kill your compost worms. Therefore, be careful about using animal waste as worm food. It is advised to start with a small amount and see if the animal waste is proper for your worm bin.

The following food wastes should be excluded from your worm diet: All citrus fruits(due to high acidity) ,plant seeds,cooking oil,meat,fish,poultry,dairy products,and salad dressings. For more information on worm foods preparation,please refer to the Section of System Optimization.

### **Worm Arrival**

When your worms arrive,place the on the surface of the worm bedding and cover the bedding with a sheet of damp newspaper. Worms will quickly disappear under the worm bed.

Note: The worms may become stressed during the shipping process. Overall, worms may take a week or so to adapt to their new home. They may try to escape from the worm bin(even when you harvest or move worms to a new tray, they may try to escape). In the first couple of days after worms' arrival, it is suggested not to use the lid to cover the bin, but to use the V-Board to cover the bin during the daytime. At night, leaving a light on near the top of the bin so that the

worms are encouraged to burrow into their new home. The V-Board is a part, which comes only with the VermiHut plus. The classic VermiHut does not come with the V-Board. The V-Board can be found inside the lid and can be easily removed out, and put back after use.

If you see the worms on the M-Board(or the drain cloth) , you may pick them up and put them back in the worm bin.

### **Worm Food Additions**

We suggest adding worm foods after the worms arrive. Bury one handful of food scraps at a corner of the worm bedding,leaving most of the tray area open for airflow. Cutting the worm foods into small pieces is strongly suggested for quicker composting. It is always recommended to cover the top of the bedding with a sheet of damp newspaper to keep the bedding moist.

For more information on worm food addition,please refer to the Section of System Operation.

A common mistake for beginner is to over-feed the worms. You have to be patient and allow a few days for the worms to become acclimatized to the worm bin,and for the micro-organisms,which are also a vital part of worm composting,to populate the bin. Do not expect to see the food disappear be for re your eyes.

## **System Operation**

---

### **Worm Food Addition**

2 to 3 weeks after the worm settles down in the bin, the worms start digesting the food. When you see approximately half of the worm foods in the bin disappear, you can add new foods. It is suggested to bury the new foods under the bedding.

The common mistake is over-feeding the worms. When worms are over-fed, part of the foods may become rotten and generate an unpleasant odor. It also produces acidic substances, lowering the pH. Worms become very inactive in low-pH environments and could die. Therefore, avoid over-feeding the worms.

The rule of thumb for feeding the worms is to add food when half of the last feed is gone.

In ideal conditions, 1 lb of red worms can consume 3 lb of food per week. The factors that impact the rate of composting are climate, temperature, humidity, pH, oxygen levels, and level of micro-organism inside the bin, and the type and amount of foods.

The ideal conditions can be achieved through efforts of trial and error. Please refer to the section on System Optimization for tips on optimizing the system.

### **Adding A New Tray**

When the first working tray is 70% full, it is time to add an upper working tray (or 2<sup>nd</sup> working tray). We suggest the procedure below for adding a tray:

1. Spread a handful of foods on the working tray to be added.
2. Cover the foods with some bedding from the 1<sup>st</sup> working tray, decayed leaves, and/or dry grasses. Or you can purchase coconut coir and mix the soaked coconut coir with soil as described in the Section of System Set-up. It is suggested to cover the foods with 1/2" bedding.
3. Add 1/2" shredded moist paper (suggested materials include: newspaper, books, cardboard or junk mail without plastic coating) on top of the bedding described in above.
4. Cover it with a couple of sheets of moist newspaper.
5. Place the new tray on top of the 1<sup>st</sup> working tray (Note: make sure that the top of the bedding in the 1<sup>st</sup> working tray comes in incomplete contact with the bottom of the 2<sup>nd</sup> working tray so that worms can travel through trays), and cover with the lid.
6. One week later, add a handful of food only on the new tray (the upper tray) and bury the foods under the bedding.
7. Continue adding foods when you see approximately half of the foods in the new tray disappear. Always bury foods under the bedding.

Here are a few tips for adding the 2<sup>nd</sup> working tray or the upper working tray:

- Make sure that the top of the bedding in the 1<sup>st</sup> working tray comes in complete contact with the bottom of the 2<sup>nd</sup> working tray so that worms can migrate through trays.

●When the 2<sup>nd</sup> working tray is 70%full,it is time to add the 3<sup>rd</sup> working tray. The way to add the 3<sup>rd</sup> working tray is the same as adding the 2<sup>nd</sup> working tray described above.

It is the same for the 4<sup>th</sup> and 5<sup>th</sup> working trays.

Notes on worm Behavior:

- Worms will migrate upward into the upper working tray to search for food.
- Worms will re-eat their food sources several times. This means worms will migrate up and down the working trays.

Therefore, it is important to make sure the bedding in the lower tray comes into incomplete contact with the bottom of the upper working tray to allow the worms to travel through the trays, and there is no hard barrier(like sheets of newspaper or others) between trays to block the worms migrating between trays.

### **Worm-castings Harvest**

Keep feeding worm foods into the top working tray. Most of the worms will migrate to the top working tray for food. The bottom working tray will contain only the worm castings or worm compost with only a few worms.

When the bedding material in the bottom tray is nearly black,and resembles soil,it is time to harvest the tray.

If the bottom tray is ready to harvest but there are still some worms in it,which you would like to keep in the bin,it is very easy to separate them from the tray to be harvested; simply remove the tray to be harvested and place it on top of the top working tray,and cover it up with the V-Board. Plow the bedding in the tray to be harvested several times during the day. The remaining worms will move down into the tray below because of the light. Once the tray is free from worms,it will be ready to harvest.

Empty the tray that is ready to harvest onto a piece of plastic sheeting. The compost is now ready to be used. Rinse the tray with water; the rinsed water also contains rich nutrition that can be used to water your plants. The cleaned tray is now a new working tray for the continuous rotating cycle.

You can also harvest the worm compost liquid from the food leach. Simply put a cup(the new VermiHut Plus comes with a cup) under the tap and open the tap to drain the liquid. The amount of liquid depends on the types of food fed into the system. If they are juicy food like watermelon,more liquid is expected. You can collect the compost liquid once a week. The liquid contains rich nutrient that can be used for plants. However,since it is a concentrated liquid fertilizer,it should be diluted with water in a 1: 2 volume ratio.

### **Air,Moisture. Temperature,and pH**

●Air. Just like any living animal,worms need oxygen.

Oxygen is also essential for aerobic bacteria,which helps compost organic materials. The VermiHut and VermiHut Plus worm bin have a special design on the M-Board and the air-vented lid to allow better airflow (the older version of VermiHut does not come with the M-Board) . However,if a worm bin is placed in an air-stagnant environment such as enclosed cabinet,it is difficult to have fresh air through the system. Therefore,a worm bin should be placed in a good ventilation area.

●Moisture. The bedding moisture is important to worms since worms take in oxygen through moisture on their surface. Please refer to the Section of Set-up and Start-up for how to check the moisture level of the bedding. Ideally,the bedding should be slightly damp. If the bedding has too much moisture or too wet,worms may crawl out of the bin. However,if the bedding is too dry,worms could die for a lack of oxygen. If the bedding is dry,use a spray bottle to spray water into the top tray.

●Temperature. The ideal temperature for the worms to compost is between 15 and 25°C(55-77°F) . In the instances of extremely hot weather,it is recommended to put the worm bin in a sheltered place with good ventilation. Never place the worm bin indirect sunlight. The plastic bin may absorb heat and cause the temperature inside the bin to be higher than the environment temperature. In extremely cold weather(less than 32F or 0°C) ,we would advise moving it inside the house. The worm bin has very minimal odor(the VermiHut Plus model comes with a sheet of coconut fiber mat to absorb the trace odor) .

●pH. The pH value in the worm bed is important to the worms. When pH is above 7, it is alkaline; pH below 7, it is acidic. A pH between 6 to 8 is acceptable.

Acidic bedding is commonly caused by adding too much food into the bin that the worms can't digest fast enough, leaving behind rotten foods that generate acidic juices. In this case, remove the excess food. Please also avoid adding acidic fruits such as orange peels into the compost bin.

If it is detected the bedding is acidic, it is recommended to add a handful of pur mice, which can be purchased at garden center. Oyster shell powder can also be used to mitigate the acidic bedding problems.

## **System Optimizations**

Theoretically, 1kg (or 2lbs) of red worms can compost 0.5kg (or 1 lb) of foods each day under ideal conditions. However, in reality, most worm bins can't reach the ideal conditions. There are many factors impacting the composting process. Based on the collective experience from many growers, we summarize the following practices and tips for ever mi-system optimizations.

### **Foods**

Worms take in foods by slurping the food juice or bacteria generated by the decomposed organic materials. Therefore, in order to speed up the worm composting process, it is important to prepare the foods in a way that can be easily composted. Below are several suggestions:

- i. Chop the food into small pieces. When the pieces are smaller, a larger surface area is exposed to open air, allowing for optimal growth of bacteria.
- ii. Freeze the food. When the foods are frozen, it is easier for them to breakdown to become soft and juicy.
- iii. Microwave the food. When the foods are cooked, they break down to become soft and juicy.

## **Moisture**

Studies have shown that worms breathe by taking in dissolved oxygen in water through their skin. Therefore, the bedding environment has to be moisturized. The bedding moisture level needs to be between 60% to 80%. Moisture meters can be used to detect the bedding moisture level. You can check the bedding moisture level, chart the worm activities, and find the optimum moisture level for your worms.

When the moisture level is too low, use a spray bottle to add water to your worm bin; when the moisture is too high, you can remove the lid to allow evaporation of the moisture, or add dry shredded paper to absorb the excess moisture.

## **Temperature**

Worms work best between 15 and 25°C (or 55-77°F). They will slow down composting beyond the ranges. Temperature gauge can be used for temperature measurement. When the bedding temperature is above 29°C (or 85°F), you should cool it down. Here are a few ways to cool down the worm bed:

- i. Spray some cold water on to the worm bed, and lift the lid off. The vapor will carry the heat out of the bin.
- ii. Separate each working tray to allow more airflow through the system. Find a few pieces of sticks or stripes and put them between each working trays. The more air flows through the system, the more heat can be carried out of the unit.
- iii. Add ice cubes to the top of your worm bin. The ice will melt into the compost to cool down the bin.

The new version of the VermiHut and the VermiHut Plus model both have the M-Board and air-vented lid design to increase airflow so that excessive heat can be carried out of the bin to maintain optimal temperature.



# **System Troubleshooting**

---

## **Mites**

Occasionally, you may notice some little white insects in the system. These are mites. They are not harmful to your worms. Their presence indicates your worm system is too acidic and/or possibly too dry. In this case, you should spray some water, a handful of oyster shell powder, or crushed eggshells on the top of the working trays.

## **Fruit Flies**

A wet and acidic environment is good for the generation of fruit flies. If the system is over-fed with foods, some foods may become rotten, and generate fruit flies.

When you see fruit flies in your worm bin, you can try the followings to get rid of them:

- i. Remove the rotten food and the excessive food;
  
- ii. Add some dry shredded paper on the top working tray to reduce the bedding moisture level;
  
- iii. Add some oyster shell powder, or crushed eggshells;
  
- iv. Always keep the food covered under the bedding.

Sometimes, the fruit fly eggs just come with the fruit peel fed to the bin.

Therefore, there will be fruit fliers coming up from the bin. However, the VermiHut Plus comes with the V-Board and a piece of coconut fiber mat to minimize the fruit fliers populating.

## **Unpleasant Odor**

If the system is managed properly, it should have very minimal odor and only when the lid is lifted, it may smell a little. If it starts to smell a lot, it indicates the system is not operating correctly.

There are a few reasons for the odor problems in the worm bin.

- i. Overfeeding the system. When foods stay in the bin for too long, and are not

being composted quickly enough by the worms, the foods will become rotten, causing odor. In this case, remove the rotten foods and the excessive foods, especially the large pieces of food.

ii. There are protein types of foods such as meats, bones, dairy products and greasy foods inside the worm bin. Worms can't compost these types of foods. When they are exposed to the air, they would naturally de-compose and smell. Avoid adding these types of foods into the worm bin. They can cause odor, lower the pH and even kill the worms.

iii. Too much moisture. Excessive moisture in the bin can also cause odor. In this case, you can add some dry shredded paper to the top tray to absorb the excessive moisture.

iv. Insufficient Oxygen. Anaerobic bacteria, which grow in the environment with lack of oxygen, carry about an unpleasant odor by nature. Use a claw to loosen the bedding to allow more air to flow through the bin. The new version of the VermiHut and the VermiHut Plus model have the M-Board design to increase airflow by over 10 times. This is a great help to maintain sufficient oxygen to the bin.

The VermiHut Plus model comes with a piece of coconut fiber mat inside the lid to remove the already minimal odor. Other worm bin models don't have this design.

### **Ants:**

Sometimes, the worm foods may invite ants to the bin. The VermiHut Plus model comes with four ant-trappers. Simply place the ant trappers under the base and fill them with water. The poor ants will be trapped in the water if they come to invade your worm bin. This is a new design for the VermiHut Plus model. Other worm bin models don't have this design.

**Manufacturer:**Shanghaimuxinmuyeyouxiangongsi

**Address:** Shuangchenglu 803nong11hao1602A-1609shi, baoshanqu, shanghai  
200000 CN.

**Imported to AUS:** SIHAO PTY LTD. 1 ROKEVA STREETEASTWOOD NSW 2122  
Australia

**Imported to USA:** Sanven Technology Ltd. Suite 250, 9166 Anaheim Place,  
Rancho Cucamonga, CA 91730

<b>EC</b>	<b>REP</b>
-----------	------------

E-CrossStu GmbH  
Mainzer Landstr.69, 60329 Frankfurt am Main.

<b>UK</b>	<b>REP</b>
-----------	------------

YH CONSULTING LIMITED.  
C/O YH Consulting Limited Office 147, Centurion House,  
London Road, Staines-upon-Thames, Surrey, TW18 4AX

**VEVOR<sup>®</sup>**

**TOUGH TOOLS, HALF PRICE**

**Technical Support and E-Warranty Certificate**

**[www.vevor.com/support](http://www.vevor.com/support)**