

# **VEVOR<sup>®</sup>**

## **TOUGH TOOLS, HALF PRICE**

Technical Support and E-Warranty Certificate [www.vevor.com/support](http://www.vevor.com/support)

### **BEE HIVE**

**MODEL: FX1+1**

We continue to be committed to provide you tools with competitive price.

"Save Half", "Half Price" or any other similar expressions used by us only represents an estimate of savings you might benefit from buying certain tools with us compared to the major top brands and does not necessarily mean to cover all categories of tools offered by us. You are kindly reminded to verify carefully when you are placing an order with us if you are actually saving half in comparison with the top major brands.

# VEVOR®

TOUGH TOOLS, HALF PRICE

BEE HIVE

MODEL: FX1+1



## NEED HELP? CONTACT US!

Have product questions? Need technical support? Please feel free to contact us:

**Technical Support and E-Warranty Certificate**  
**[www.vevor.com/support](http://www.vevor.com/support)**

This is the original instruction, please read all manual instructions carefully before operating. VEVOR reserves a clear interpretation of our user manual. The appearance of the product shall be subject to the product you received. Please forgive us that we won't inform you again if there are any technology or software updates on our product.



Warning-To reduce the risk of injury, user must read instructions manual carefully.

## INSTALLATION NOTES

### NOTES:

1. Try to choose hard ground for installation.
2. Prepare installation tools in advance (Rubber hammer and wood).
3. Carefully read this installation manual and confirm the quantity of accessories according to the list.

## MODEL AND PARAMETERS

Model	FX1+1
Product size	562*462*515mm
Cabinet material	Fir wood
Surface treatment	Wax boiling process

## COMPONENTS

 <b>A1 240 Coaming 1(x2)</b>	 <b>B1-1</b> <b>B1-2</b> <b>B1 240 Coaming 2(x2)</b>
 <b>A2 170 Coaming 1(x2)</b>	 <b>B2-1</b> <b>B2-2</b> <b>B2 170 Coaming 2(x2)</b>



**C** 170/240 Main frame bar 1(×20)



**D** 170/240 Main frame bar 2(×20)



**E1** 240 Frame bar (×20)



**E2** 170 Frame bar (×20)



**F1** 240 Foundation sheet (×10)



**F2** 170 Foundation sheet (×10)



**G** Handle (×2)



**H** Screw M4x30 (×2)



**I-1**      **I-2**  
**I** Window pane (×2)



**J** Self-tapping screw M4x20 (×4)



**K** Small plank (×4)



**L** Top Cover (×1)



**M** Inner Cover (×1)



**N** Bottom Board(×1)

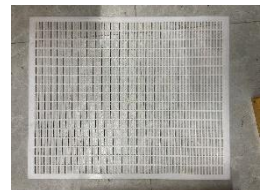

**O** Queen Excluder (×1)



**P** Entrance Reducer(x1)



**Q** iron nails (x80)



**R** Self-tapping screw  
M3x12 (x8)



**S** Acrylic panel window (x2)

## ASSEMBLY

### 240 BOX

#### 1. Installation of 240 box

**Step 1:** Take two pieces of **A1** and two pieces of **B1(B1-1&B1-2)** respectively, and connect them with a rubber hammer (note that it is not allowed to knock them directly, but put a board or cardboard on them and knock them in evenly).

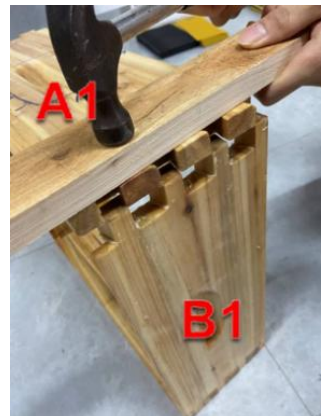
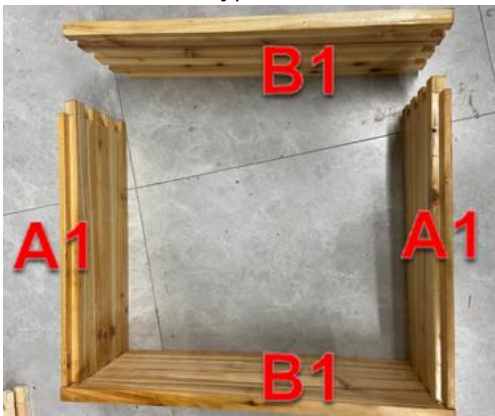

## 2. Installation of 240 frame

**Step 1:** Take 2 pieces of **E1** and 1 piece of **C**, insert them into the card slot to connect them, then take 1 piece of **F1** and insert it into the slot, and finally take 1 piece of **D** and insert it into the slot to complete a set of 170 frames.

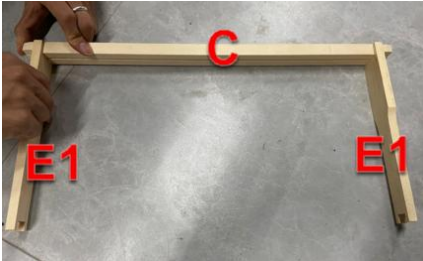

**Step 2:** Connect with 4 pieces of **Q** at a/b/c/d 4 positions.

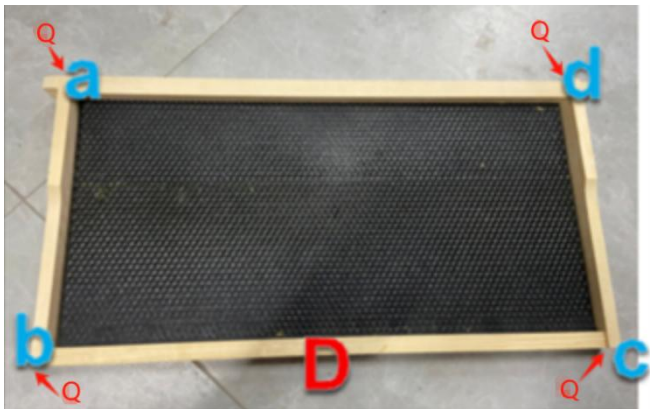

## 3. Installation of the window

**Step 1:** Take **G**, **H** and **I-1** to assemble the cover plate.



**Step 2:** Take **S** and Peel off the film from the corners, then Take **S** and **R** to assemble the Coaming.



**Step 3:** Take **J** and **K** to assemble the window pressing plates on both sides and put 10 sets of foundations and frames into the box.



# 170 BOX

## 4. Installation of 170 box

**Step 1:** Take two pieces of **A2** and two pieces of **B2(B2-1&B2-2)** respectively, and connect them with a rubber hammer (note that it is not allowed to knock them directly, but put a board or cardboard on them and knock them in evenly).

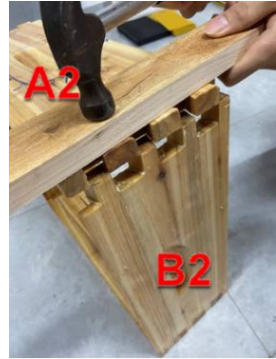
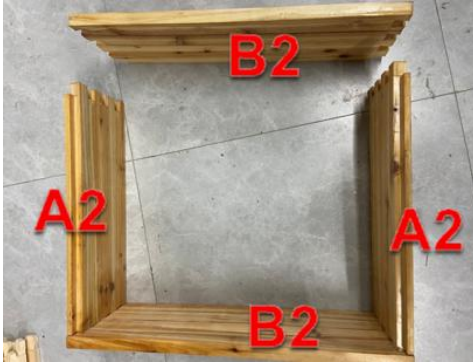

## 5. Installation of 170 frame

**Step 1:** Take 2 pieces of **E2** and 1 piece of **C**, insert them into the card slot to connect them, then take 1 piece of **F2** and insert it into the slot, and finally take 1 piece of **D** and insert it into the slot to complete a set of 170 frames.

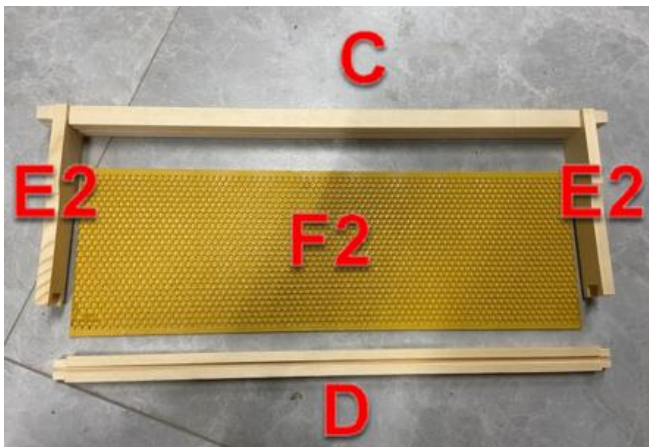



**Step 2:** Connect with 4 pieces of **Q** at a/b/c/d 4 positions.

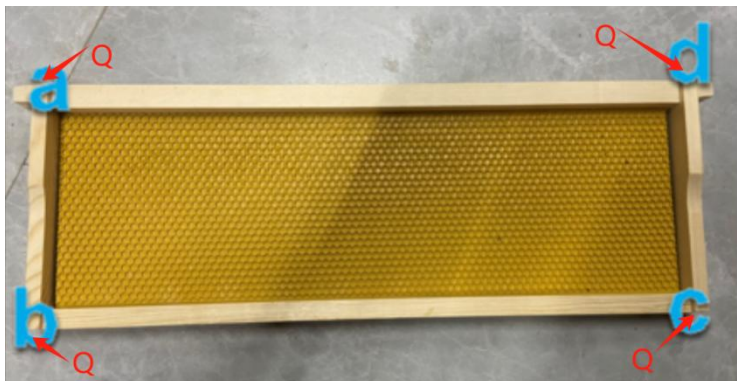

## 6. Installation of the window

**Step 1:** Take **G**, **H** and **I-2** to assemble the cover plate.



**Step 2:** Take **N** and Peel off the film from the corners, then Take **N** and **M** to assemble the Coaming.





**Step 3:** Take J and K to assemble the window pressing plates on both sides and put 10 sets of foundations and frames into the box.



**Finally, please assemble according to the following figure:**

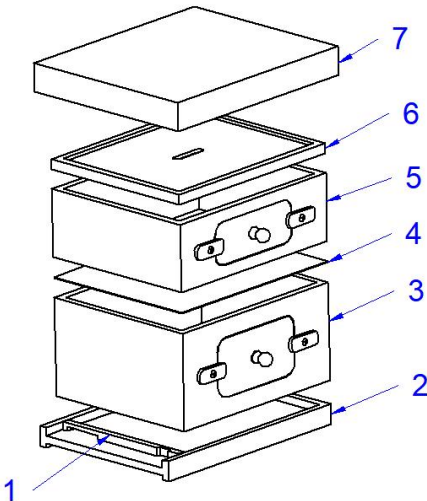

1. Entrance Reducer
2. Bottom Board
3. 240 Box
4. Queen Excluder
5. 170 Box
6. Inner Cover
7. Top Cover

## MAINTENANCE

1. Please use beeswax regularly for maintenance.
2. Close the bee window in cold, rainy, and windy weather.

Manufacturer: Shanghai muxinmuyeyouxiangongsi

Address: Shuangchenglu 803nong11hao1602A-1609shi, baoshanqu, shanghai 200000 CN.

EC REP: E-CrossStu GmbH.

Mainzer Landstr.69, 60329 Frankfurt am Main.

UK REP: YH CONSULTING LIMITED.

C/O YH Consulting Limited Office 147, Centurion House, London Road, Staines-upon-Thames, Surrey, TW18 4AX

Imported to AUS: SIHAO PTY LTD.

1 ROKEVA STREET EASTWOOD NSW 2122 Australia

Imported to USA: Sanven Technology Ltd.

Suite 250, 9166 Anaheim Place, Rancho Cucamonga, CA 91730

**VEVOR<sup>®</sup>**  
**TOUGH TOOLS, HALF PRICE**

**Technical Support and E-Warranty Certificate**  
**[www.vevor.com/support](http://www.vevor.com/support)**