

VEVOR[®]

TOUGH TOOLS, HALF PRICE

Technical Support and E-Warranty Certificate www.vevor.com/support

SINGLE SWING GATE OPENER

MODEL: EK280/EK365/EK700M

We continue to be committed to provide you tools with competitive price.

"Save Half", "Half Price" or any other similar expressions used by us only represents an estimate of savings you might benefit from buying certain tools with us compared to the major top brands and does not necessarily mean to cover all categories of tools offered by us. You are kindly reminded to verify carefully when you are placing an order with us if you are actually saving half in comparison with the top major brands.

VEVOR[®]

TOUGH TOOLS, HALF PRICE

SINGLE SWING GATE OPENER

MODEL: EK280/EK365



MODEL: EK700M



NEED HELP? CONTACT US!

Have product questions? Need technical support? Please feel free to contact us:

Technical Support and E-Warranty Certificate
www.vevor.com/support

This is the original instruction, please read all manual instructions carefully before operating. VEVOR reserves a clear interpretation of our user manual. The appearance of the product shall be subject to the product you received. Please forgive us that we won't inform you again if there are any technology or software updates on our product.



Warning-To reduce the risk of injury, user must read instructions manual carefully.



This product is subject to the provision of European Directive 2012/19/EC. The symbol showing a wheeled bin crossed through indicates that the product requires separate refuse collection in the European Union. This applies to the product and all accessories marked with this symbol. Products marked as such may not be discarded with normal domestic waste, but must be taken to a collection point for recycling electrical and electronic devices

- ★ Please read and follow all warnings, precautions and instructions before installation and use.
- ★ A 24VDC battery (NOT INCLUDED, 2PCS 12VDC batteries can be connected in series to become 24VDC) is required to power the gate opener. Adapter which is included in the package is used to charge the battery.
- ★ Never connect the solar panel to the control board directly to charge the battery.
- ★ Periodic checks of the opener are required to ensure safe operation.
- ★ Save this manual.

Safety Installation Information

1. READ and FOLLOW all instruction.
2. The gate opener is intended for use with Class I vehicular swing gates. Class I denotes a vehicular gate opener (or system) dwelling, or a garage or parking area associated therewith.

Install the gate opener only when the opener is appropriate for the construction and the usage class of the gate.

3. Gate opening system designers, installers and users must take into account the possible hazards associated with each individual application. Improperly designed, installed or maintained systems can create risks for the user as well as the bystander. Gate system design and installation must reduce public exposure to potential hazards. All exposed pinch points must be eliminated or guarded.

4. A gate opener can create high levels of force during normal operation. Therefore, safety features must be incorporated into every installation. Specific safety features include safety sensors.

5. The gate must be properly installed and work freely in both directions prior to the installation of the gate opener.

6. The gate must be installed in a location so that enough clearance is provided between the gate and adjacent structure when opening and closing to reduce the risk of entrapment. Swinging gates shall not open into public access areas.

7. The opener is intended for use only on gates used for vehicles. Pedestrians must be supplied with a separate access opening. The pedestrian access opening shall be designed to promote pedestrian usage. The pedestrian access shall be located such that persons will not come in contact with the moving vehicular gate.

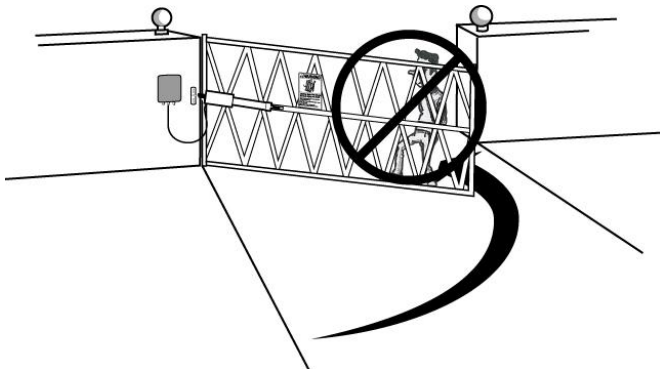

8. Pedestrians should never cross the pathway of a moving gate. The gate opener is not acceptable for use on any pedestrian gate. Pedestrians must be supplied with a separate pedestrian access.
9. For an installation utilizing non-contact sensors (safety sensors), see product manual on the placement of non-contact sensors (safety sensors) for each type of application.
 - a. Care shall be exercised to reduce the risk of nuisance tripping, such as when a vehicle trips the safety sensor while the gate is still moving.
 - b. One or more non-contact sensors (safety sensors) shall be located where the risk of entrapment or obstruction exists, such as the perimeter reachable by a moving gate or barrier.
10. Never mount any device that operates the gate opener where the user can reach over, under, around or through the gate to operate the controls. Controls are to be placed at least 6' (1.8m) from any part of the moving gate.

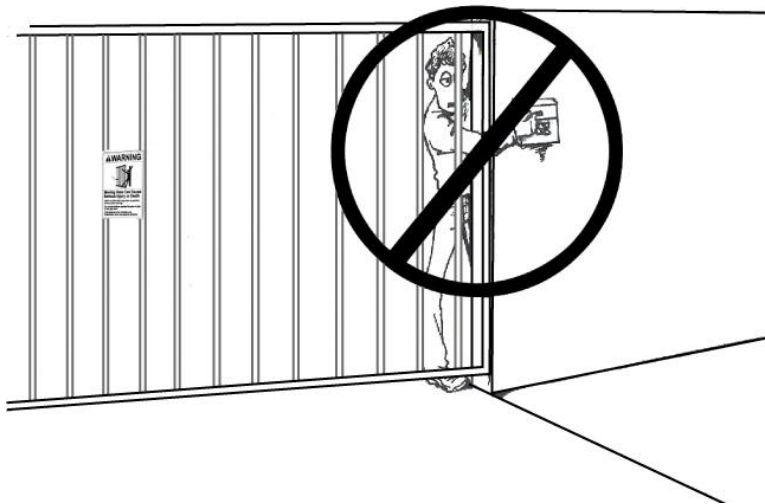

11. Controls intended to be used to reset an operator after 2 sequential activations of the entrapment protection device or devices must be located in the line of sight of the gate, or easily accessible controls shall have a security feature to prevent unauthorized use. Never allow anyone to hang on or ride the gate during the entire travel of the gate.

12. Each gate opener is provided with two safety warning placards. The placards are to be installed on the front and back of the gate where they are plainly visible. The placards may be mounted using cable ties through the four holes provided on each placard.

All warning signs and placards must be installed where visible in the area of the gate.

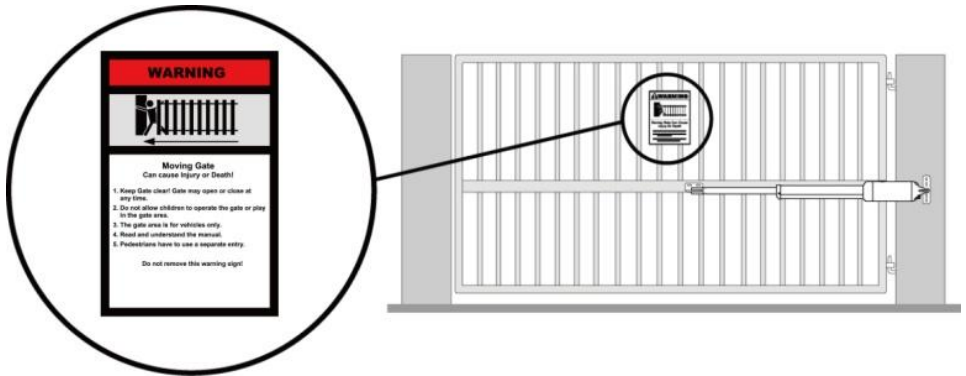



















13. To AVOID damaging gas, power, or other underground utility lines, contact underground utility locating companies BEFORE digging.

SAVE INSTRUCTION.











 WARNING
To prevent SERIOUS INJURY or DEATH from a moving gate: <ul style="list-style-type: none">• Install warning signs on the front and back of the gate in PLAIN VIEW.• Permanently secure each warning sign in a suitable manner using fastening holes.

14. Do not permit children to play on or around the gate and keep all controls out of their reach.

EK280 Parts List

 <p>Gate Opener (1 pc) <EK 280></p>				
 <p>Control Box (1 pc)</p>	 <p>CE Remote Control (1 pcs)</p>  <p>Release Key (2 pcs)</p>	 <p>Warning Signs (2 pcs)</p>		
 <p>AC Transformer (1 pc)</p>	 <p>Battery Cable (1 pc)</p>	 <p>Post Bracket (1 pc)</p>	 <p>Post Pivot Bracket (1 pc)</p>	 <p>Gate Bracket (1 pc)</p>
Hardware				
 <p>Φ10 Washer (5 pcs)</p>	 <p>M10×200 Bolt (2 pcs)</p>			
 <p>Φ10 Lock Washer (5 pcs)</p>	 <p>M10×75 Bolt (2 pcs)</p>			
 <p>Φ8 Washer (1 pc)</p>	 <p>M10×30 Bolt (1 pc)</p>			
 <p>M10 Nut (5 pcs)</p>	 <p>M8×30 Bolt (1 pc)</p>			
 <p>M8 Nut (1 pc)</p>	 <p>12×40 Clevis Pin (1 pc)</p>			
 <p>Hairpin Clip (2 pcs)</p>	 <p>12×30 Clevis Pin (1 pc)</p>			

EK365/700M Parts List

				
	Gate Opener (1 pc) <EK 365>	Gate Opener (1 pc) <EK 700M>		
				
	Control Box (1 pc)		CE Remote Control (1pc for EK365 / 2pcs for EK700M)	
		Warning Signs (2 pcs)		
				
AC Transformer (1 pc)	Battery Cable (1 pc)	Post Bracket (2 pcs)	Post Pivot Bracket (1 pc)	Gate Bracket (1 pc)
Hardware				
				
Φ10 Washer (7 pcs)	M10×200 Bolt (4 pcs)			
				
Φ10 Lock Washer (7 pcs)	M10×75 Bolt (2 pcs)			
				
Φ8 Washer (1 pc)	M10×30 Bolt (1 pc)			
				
M10 Nut (7 pcs)	M8×30 Bolt (1 pc)			
				
M8 Nut (1 pc)	12×40 Clevis Pin (1 pc)			
				
Hairpin Clip (2 pcs)	12×30 Clevis Pin (1 pc)			

Optional Accessories Parts List

EK280			
Alarm Lamp (TB-72E)			
EK365 & EK700M			
Alarm Lamp (TB-72E)		Photocell Beam System (LM102)	

NOTE: Connecting wire for accessories are needed, but not included.
Recommended 2*0.3 sq.mm (22AGW) or thicker wire.

Tools Needed

- Power Drill
- Tape Measure
- Open End Wrenches — 14# & 17# or Adjustable Wrenches
- Wire Strippers
- C-Clamps — small, medium, and large
- Level
- Hacksaw or Heavy Duty Bolt Cutters
- Phillips Screwdriver
- An extra person will be helpful

Technical Specifications & Features

Specifications			
	EK 280	EK 365	EK 700M
Rated power input:	220-240V AC /50Hz		
Rated voltage of motor:	24VDC		
Rated power of motor:	30W	50W	80W
Rated current of motor:	1.5A	2A	3A
Actuator speed:	20mm/s(0.8 in/s)		
Max. actuator travel:	385mm (15.2 in)		
Ambient Temperature:	-22°C~ +55°C (-4°F to 122°F)		
Protection class:	IP44		

Gate Capacity of EK280

Gate Weight	200kg	✓	NR	NR	NR	NR
	160kg	✓	✓	NR	NR	NR
	120kg	✓	✓	✓	NR	NR
	80kg	✓	✓	✓	✓	NR
	50kg	✓	✓	✓	✓	✓
		1.2m	1.8m	2.4m	3m	3.6m
Gate Length						

Gate Capacity of EK365

Gate Weight	300kg	✓	NR	NR	NR	NR	NR
	250kg	✓	✓	NR	NR	NR	NR
	200kg	✓	✓	✓	NR	NR	NR
	150kg	✓	✓	✓	✓	NR	NR
	100kg	✓	✓	✓	✓	✓	NR
	50kg	✓	✓	✓	✓	✓	✓
		1.2-1.8m	2.4m	3m	3.6m	4.3m	5m
Gate Length							

Gate Capacity of EK700

Gate Weight	400kg	✓	NR	NR	NR	NR	NR	NR
	350kg	✓	✓	NR	NR	NR	NR	NR
	300kg	✓	✓	✓	NR	NR	NR	NR
	250kg	✓	✓	✓	✓	NR	NR	NR
	200kg	✓	✓	✓	✓	✓	NR	NR
	160kg	✓	✓	✓	✓	✓	✓	NR
	110kg	✓	✓	✓	✓	✓	✓	✓
		1.2-1.8m	2.4m	3m	3.6m	4.3m	5m	5.5m
Gate Length								

Features:

- Soft start and soft stop
- Emergency release key in case of power failure
- Fast selecting push/pull to open
- Stop in case of obstruction during gate opening.
- Reverse in case of obstruction during gate closing.
- Built in adjustable auto-close (0-100 seconds).
- Built in max. Motor running time (MRT) for multiple safety protection (40 seconds).
- Reliable electromagnetism limit for easy adjustment.
- Can be equipped with a wide range of accessories.

Installation Overview

Single Gate Overview

Pull-to-Open Gate

⚠ WARNING To prevent SERIOUS INJURY or DEATH , at least one non-contact sensor should be located where the risk of entrapment or obstruction exists.
--

Left-Hand Gate

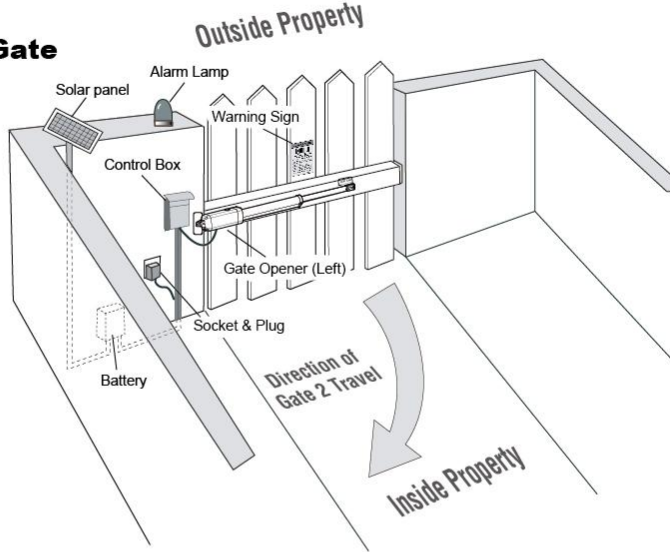

Right-Hand Gate

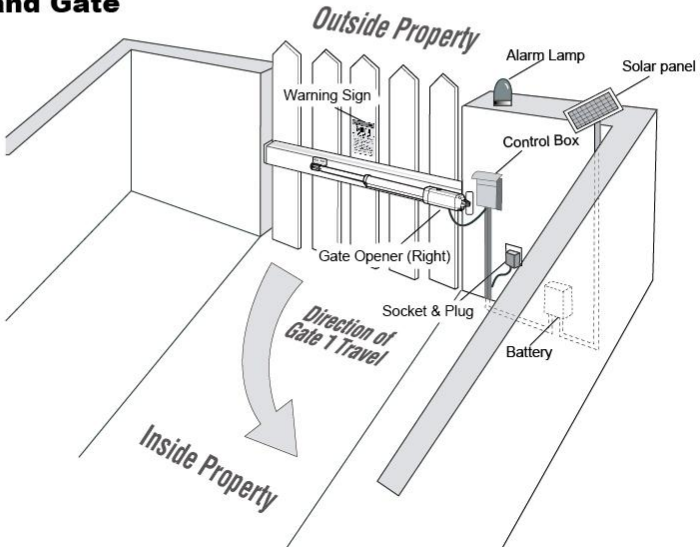

Preparation for Installation

There are two installation types for the gate opener, **Pull-to-Open** and **Push-to-Open**.

In the **Push-to-Open** installation, gate opens out from the property. A Push-To-Open Bracket (**PSO part**) is required to be used for each gate.

NOTE: Ensure the gate does not open into public areas.

The gate opener is mounted to the gate and to the gate post. Both round and square posts can be used because the Post Brackets are curved. When mounting the Post Brackets, use bolts long enough to pass through the entire post. M10 x 200 bolts are included. Concrete anchors are not provided.

When mounting the Post Brackets to wooden posts, a larger-size washer or metal plate should be used between the bolts and the wooden post to ensure the stability of the fastening hardware. If the post is smaller than 6" diameter or square, it should be made of metal and set in cement to ensure its stability.

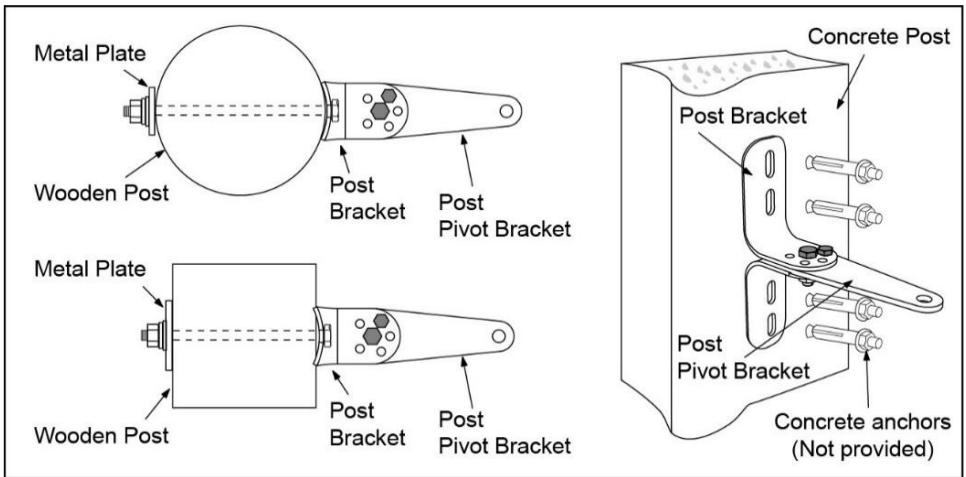

Install the Gate Opener on the Gate

The position of Post Bracket is very important. The following illustrations and tables are required to determine the proper mounting position for the Post Bracket. The tables show the maximum opening angle of the gate for a given A and B. For example, if A is 16cm and B is 14cm, the maximum opening angle of the gate is 110°

Pull-to-Open Installation — Gate in Closed position (Moving-Rod is extended)

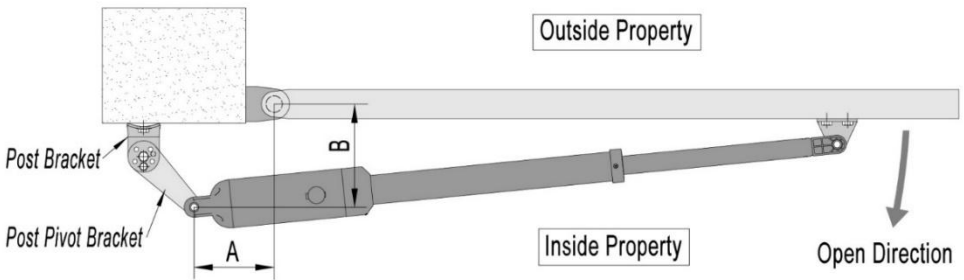

	A=10cm	A=12cm	A=14cm	A=16cm	A=18cm	A=20cm	A=22cm	A=24cm	A=26cm
B=10cm	90°	99°	106°	116°	118°	120°	111°	104°	100°
B=12cm	90°	98°	105°	113°	116°	112°	105°	99°	95°
B=14cm	90°	97°	104°	110°	111°	105°	99°	94°	91°
B=16cm	90°	96°	103°	109°	103°	99°	94°	90°	87°
B=18cm	90°	95°	101°	103°	96°	93°	89°	86°	83°
B=20cm	90°	95°	99°	95°	90°	87°	84°	81°	79°
B=22cm	90°	94°	95°	88°	84°	82°	80°	78°	76°
B=24cm	90°	93°	87°	82°	79°	78°	76°	74°	73°
B=26cm	90°	87°	81°	77°	75°	73°	72°	71°	70°
B=28cm	84°	79°	75°	73°	71°	69°	69°	68°	68°

Push-to-Open Installation — Gate in Closed position (Moving-Rod is retracted)

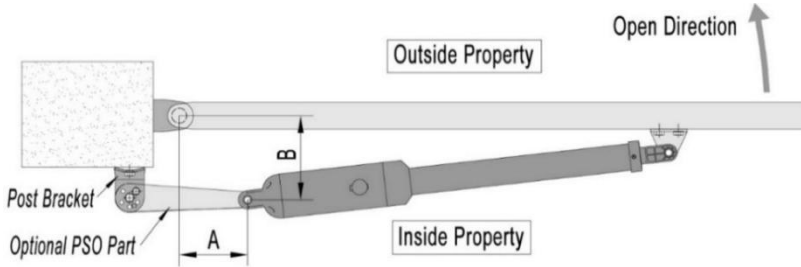

	A=15cm	A=13cm	A=11cm	A=9cm
B=10cm	112°	105°	95°	86°
B=12cm	110°	103°	95°	86°
B=14cm	107°	101°	95°	86°
B=16cm	105°	100°	94°	86°
B=18cm	104°	99°	93°	86°
B=20cm	103°	98°	93°	86°
B=22cm	103°	97°	92°	87°
B=24cm	95°	97°	92°	87°
B=26cm	88°	96°	92°	87°
B=28cm	82°	91°	91°	87°

1. Insert the M10 x 35 bolts through the center hole of the post bracket and post pivot bracket as shown. Place a \varnothing 10 washer , \varnothing 10 lock washer and M10 nut on the bottom of the bolt and hand tighten.

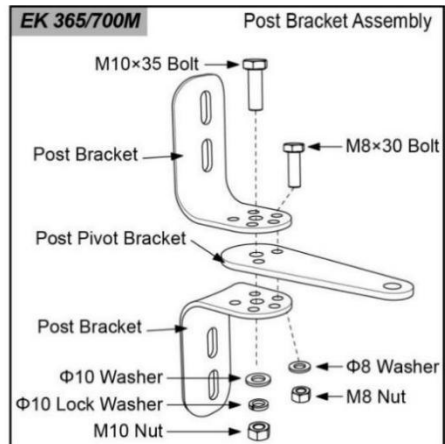
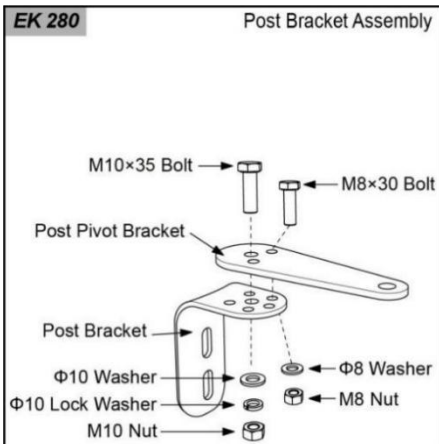

2. Attach the gate bracket and post bracket assembly to the opener by inserting a clevis pin. Secure the clevis pins using the hairpin clips.

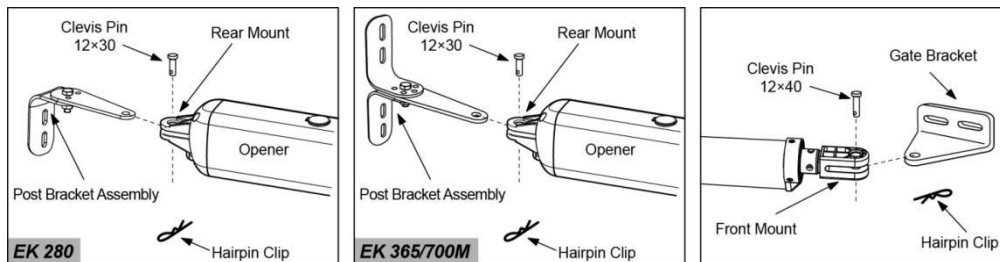

3. Open the release hole plug on the top of the gate opener, insert the release key, and turn the key 90° clockwise. This releases the motor and allows the push-pull rod to be manually extended and retracted. To restore normal operation, turn the key 90° counterclockwise.

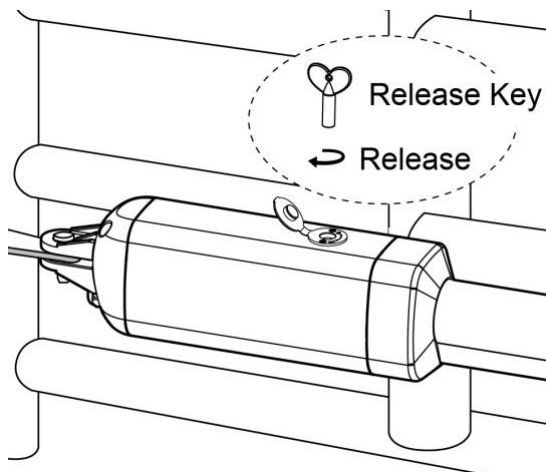

4. With the opener fully retracted and with the gate in the fully open position (for Pull-to-Open installation) or fully closed position (for Push-to-Open installation), place the gate opener with the Post Bracket Assembly and Gate Bracket on the gate post and the gate. Position the Post Bracket Assembly and Gate Bracket so that the gate opener is level. While holding the gate opener in the level position, temporarily secure it with two C-clamps.

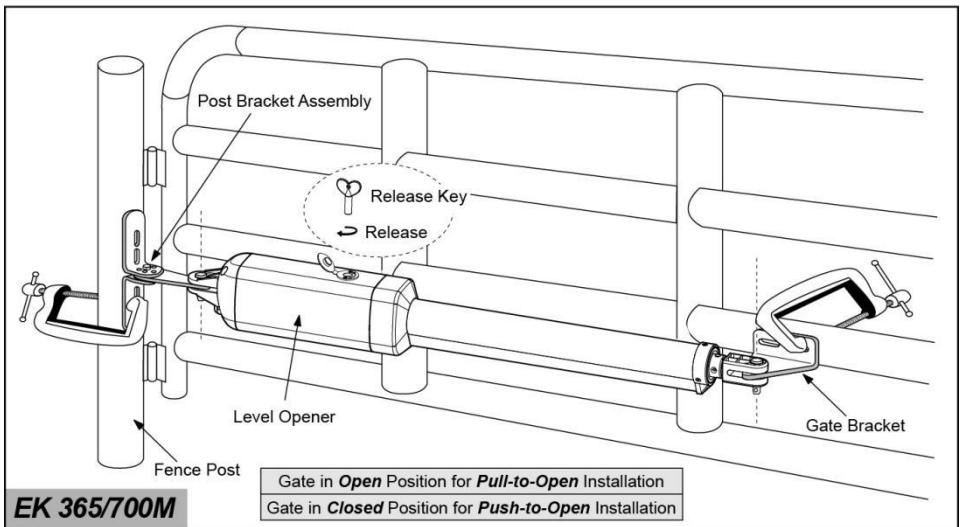
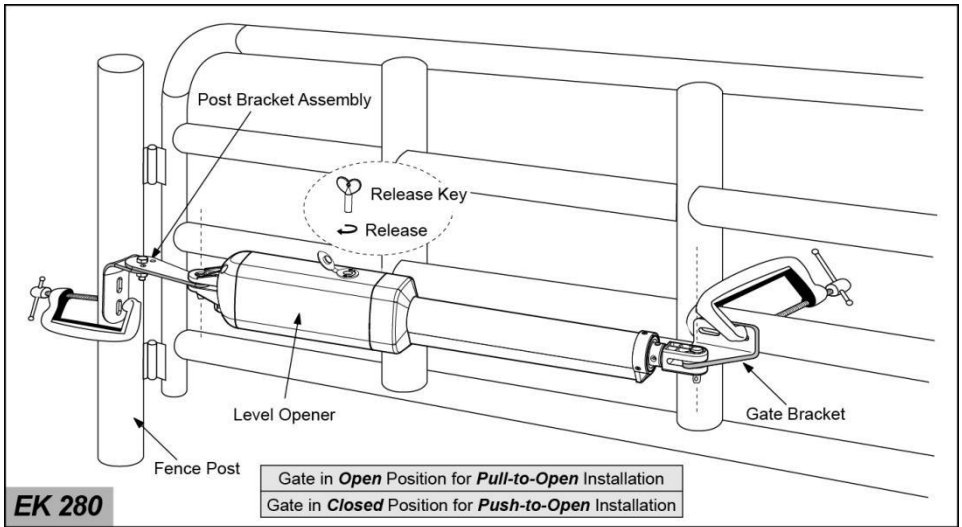

5. Make sure that there is a minimum clearance of 2.5cm between the gate and the opener and that the opener and the Post Pivot Bracket are not binding in both the gate-open and gate-closed positions. If there is not at least 2.5cm of clearance or if the opener and the Post Pivot Bracket are binding, rotate the Post Pivot Bracket and/or move the Post Bracket Assembly to obtain the minimum clearance and eliminate the binding. When the minimum clearance has been obtained and any binding has

been eliminated, place the M8 x 30 bolts through the aligned holes in the Post Bracket and the Post Pivot Bracket.

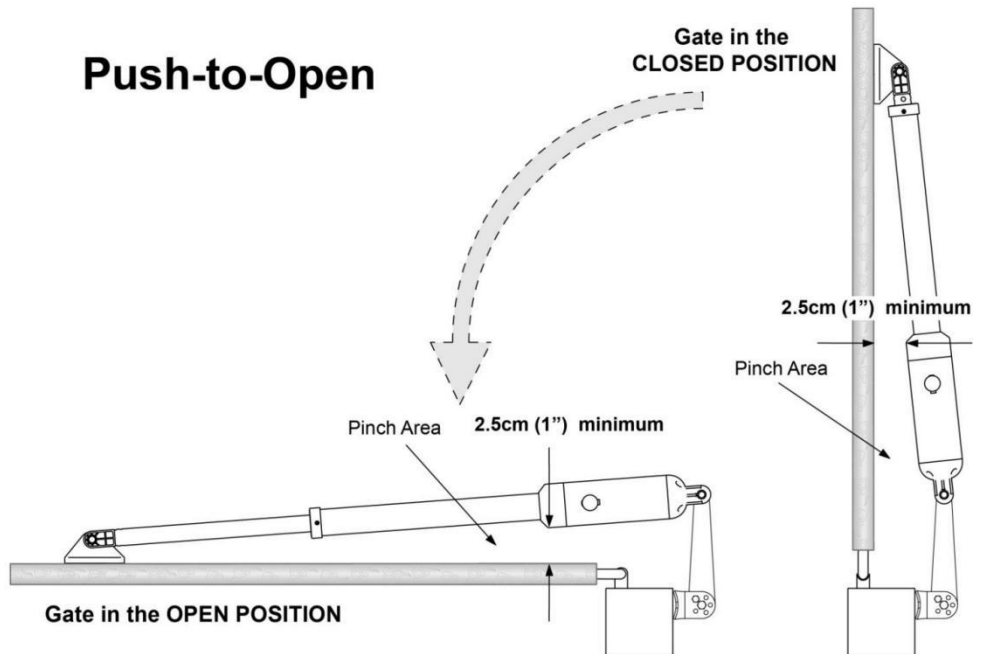
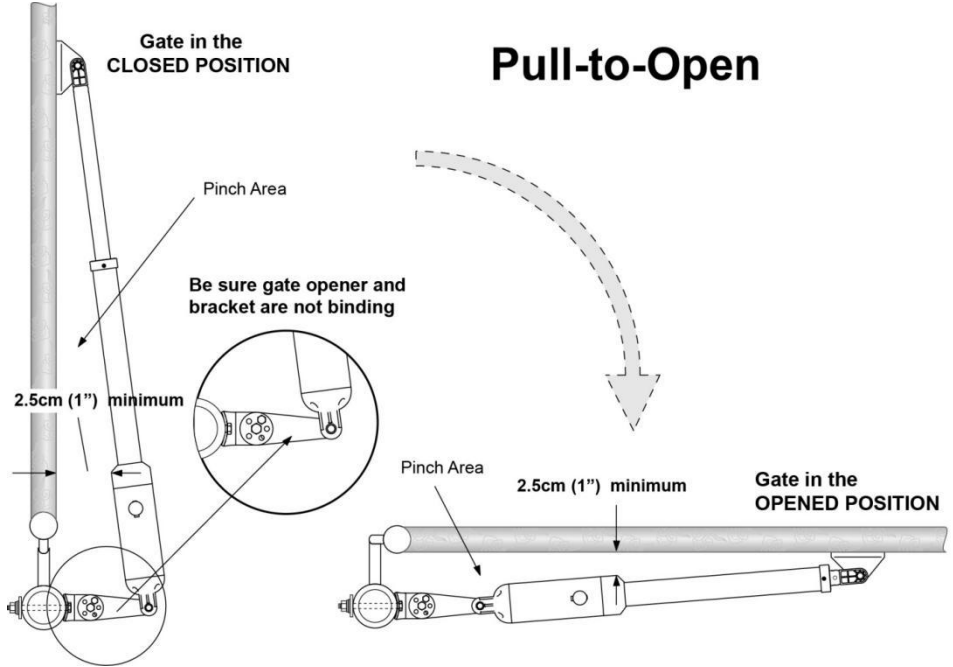

6. Sign the bolt-hole point on the gate bracket and gate. Do this by placing a punch or a sign in the middle of each bolt slot on the post bracket assemblies and the gate bracket. It allows slight adjustments to the post bracket. Then remove the post bracket and gate bracket by taking off the C-clamps.

7. Drill 10.5 mm diameter holes through the post and the gate at the marked locations.

8. Attach the post bracket assemblies to the gate posts by inserting M10 x 200 bolts through each post bracket assembly and the drilled holes in the gate post. Fasten each bolt with one \varnothing 10 washer, one \varnothing 10 lock washer, and one \varnothing 10 nut.

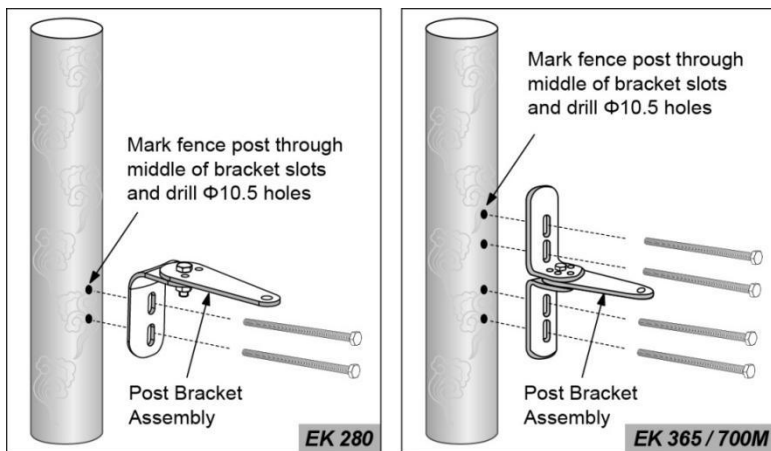

9. Attach the gate brackets to each gate by inserting two M10 x 75 bolts through the gate brackets and the drilled holes in the gates. Fasten each bolt with one \varnothing 10 lock washer, and one \varnothing 10 nut.

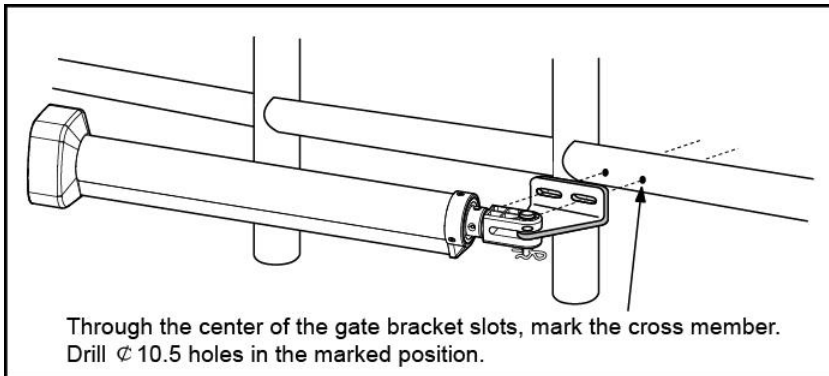

- 10.** Cut off any part of the bolts that extend beyond the tightened nuts.
- 11.** With the gate opener fully retracted and with the gate in the fully open position (for Pull-to-Open installation) or fully closed position (for Push-to-Open installation), attach the gate opener to the Post Bracket Assembly and the Gate Bracket by inserting a clevis pin through the gate opener and the Post Pivot Bracket and another clevis pin through the gate opener and the Gate Bracket. Secure each clevis pin with a hairpin clip.

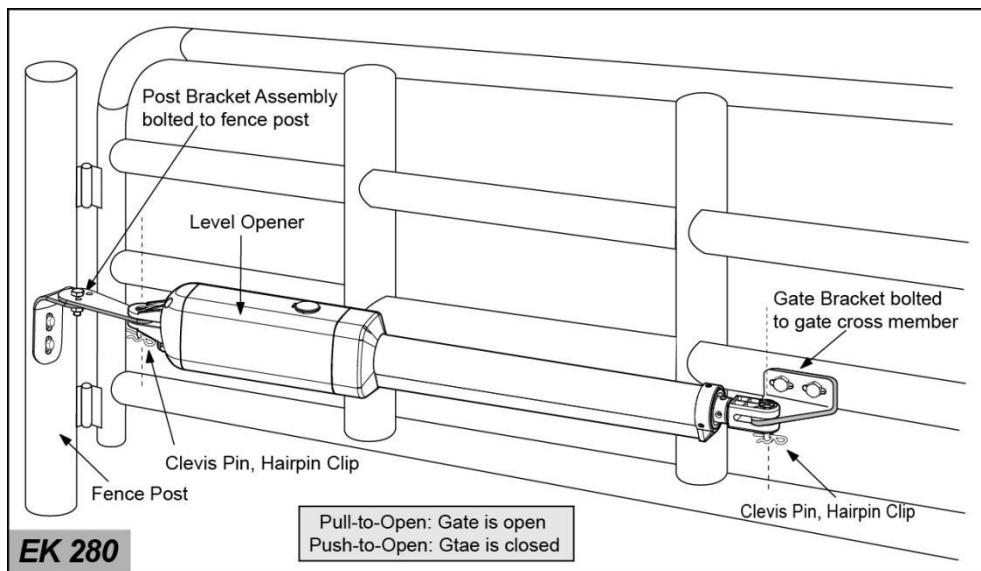

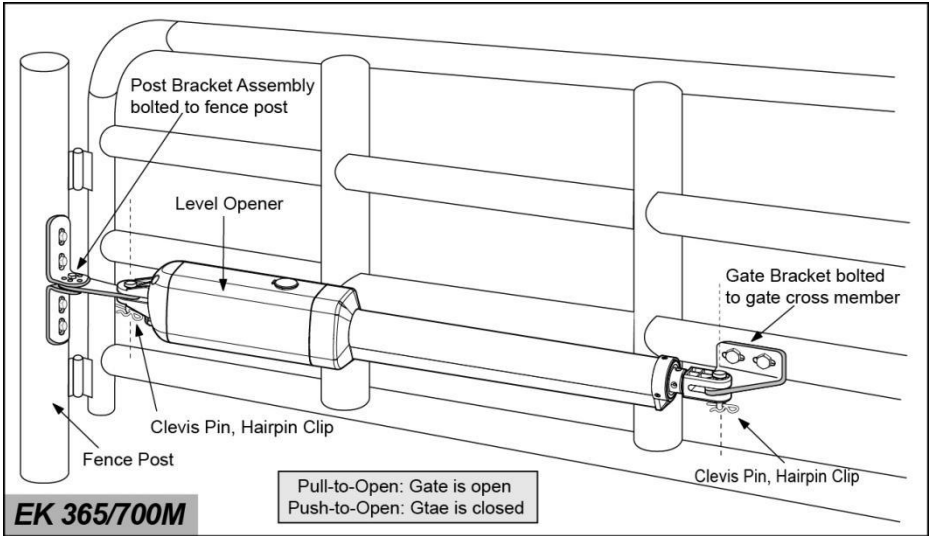

12. Open the release hole plug on the top of the gate opener, insert the release key, and turn the key 90° counterclockwise. This restores normal operation.

Mounting of the control box

Use 2 deck screws (not provided) to install the control box. Even though the control box is waterproof designed, for safety reason and a longer service life, it is recommended to install the control box inside a secure surface and at least 100 cm (40 inches) above the ground to avoid being flooded or buried under snow.



CAUTION: Make sure that the cable outlet hole in the Control Box is always down during installation, so as to drain off the water.

Connection of the power supply

⚠ The gate opener can be powered by 24V 12Ah battery (NOT INCLUDED) OR DPS180-U AC-DC Power Supply (NOT INCLUDED). The adapter included in the package is ONLY used to charge the battery.

⚠ Instead of using a battery, the AC-DC Power Supply is highly recommended as the power source to save the cost where AC electricity is accessible and stable.

⚠ If batteries are chosen as the power source, Marine or Automotive Type Battery with capacity

greater than 12 Ah is required. The batteries should be waterproof type, or be placed in water proof circumstance.

⚠ 2 PCS 12VDC batteries can be connected in series to function as 24VDC. The following diagram shows on how to connect 2 PCS batteries in series.

Charging mode for the battery could be by the adapter, by the solar panel, or both of them at the same time.

⚠ Please note that the wire connection of the power supply system is very important. Incorrect wire connection will damage the control board.

⚠ WARNING: NEVER connect the gate opener to the power outlet before all the installations have been done.

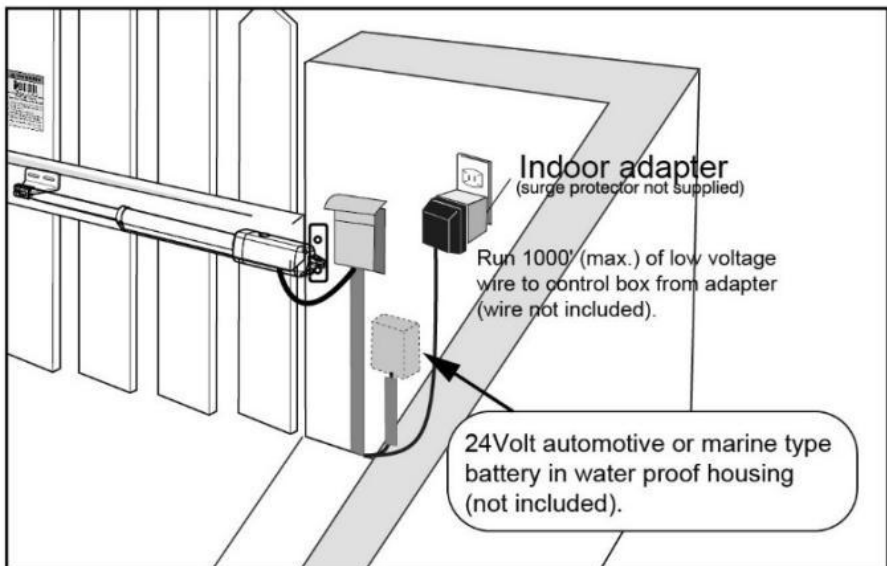

1. Use the AC-DC power supply as the power source

The gate opener can be powered by a 24VDC AC-DC power supply (**NOT INCLUDED**) with minimum output power 150W if the AC electrify is stable. It will save the cost to instead of purchasing 2 PCS 12V batteries. The positive output of the 24VDC power supply should be wired to the **BAT+ (#11)** terminal, the negative output should be wired to “**BAT-” (#12)** terminal. **It's no need to use the adapter which is included in the package in this situation.**

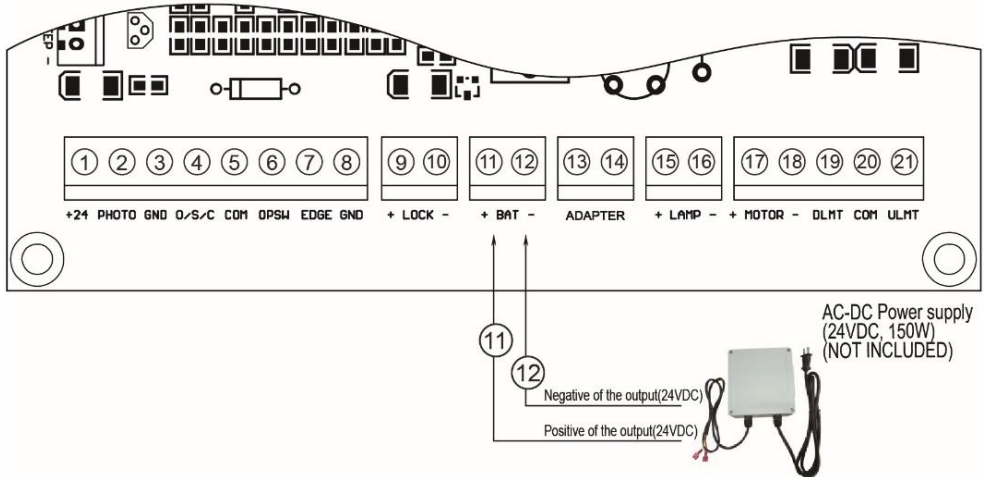

2. Use the batteries as the power source and only use the adapter to charge the batteries

The “24V+” of the battery should be wired to the **BAT+ (#11)** terminal, “24V-” should be wired to “**BAT-” (#12)** terminal. **The wire (2*0.75mm², 1meter long) for connecting the battery has been provided and connected to the control board in factory.** The adapter should be wired to the “**ADAPTER” (#13, #14)** terminals of the control board, no matter the polarity. The length of the wire of the adapter is 1.5m (5’). So if the distance between the outlet and the control box is longer than that, you should use an extended wire to connect the adapter to the control board. The wire size

should be at least 16AWG. If the distance is more than 100m (300'), the wire size should be at least 14AWG. The maximum distance from the adapter to the control box is 300m (1000').

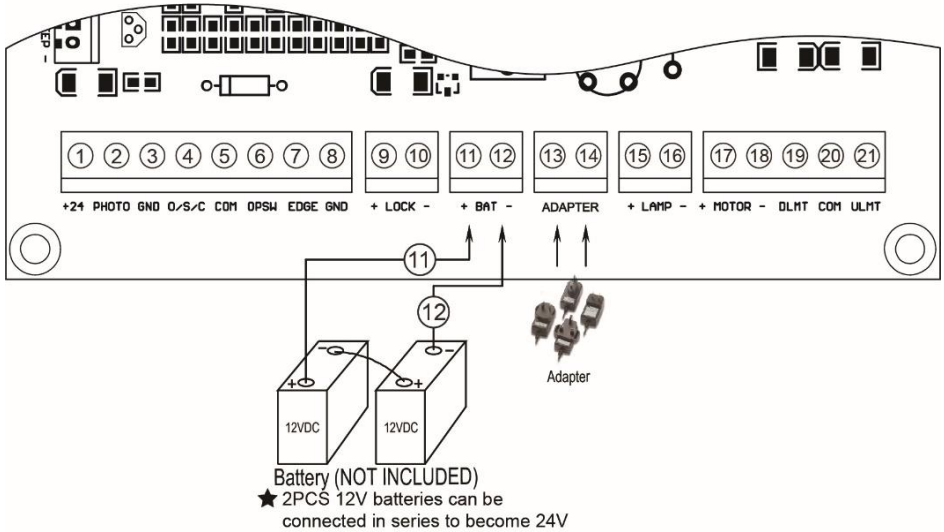

You can plug the adapter into the electrical outlet after all the wire connections are completed. Use a surge protector with the adapter is strongly recommended. If electrical outlet is located outdoors, outlet and adapter should be protected by a weatherproof cover.

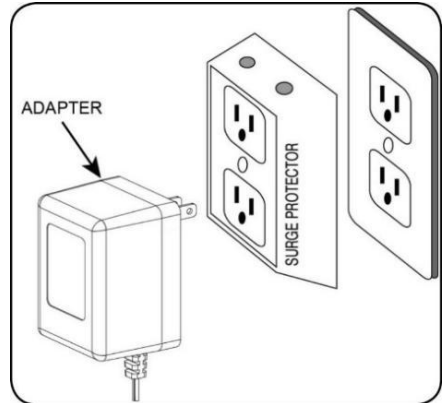

3. Use the batteries as the power source and use the adapter & solar panel to charge the batteries at the same time

If you want to use an optional solar panel to charge the battery with the adapter at the same time, a solar charge controller must be used to control it to charge the battery. You can connect adapter; the solar panel and the solar charge controller refers to the following illustration.

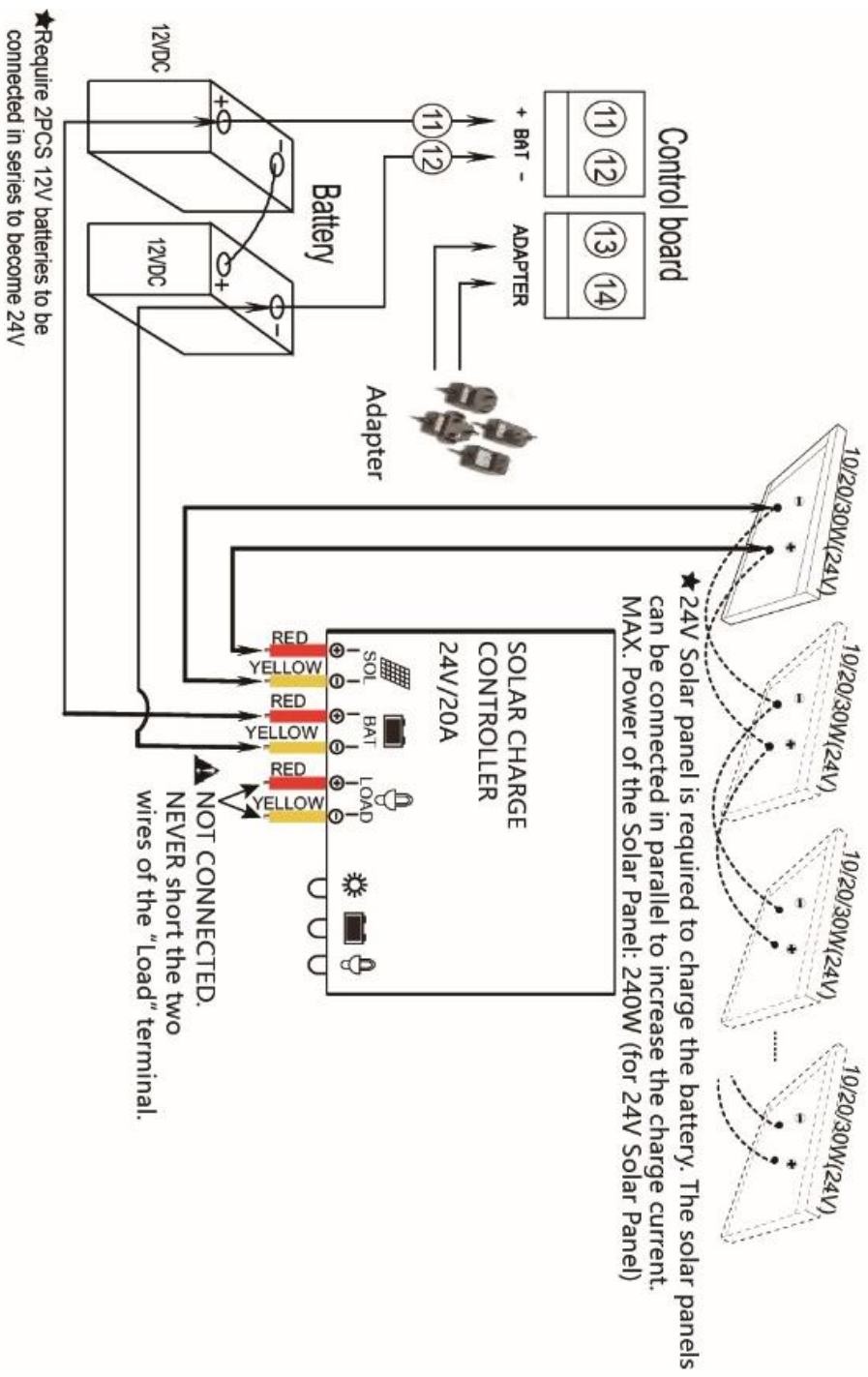

4. Use the batteries as the power source and only use the solar panel to charge the batteries

If you only use the solar panel to charge the batteries, please note the power of the solar panel should be at least 20W. The gate opener can work for 10 cycles if there is no other accessory except photocell & electric lock & push button & alarm lamp connected to the control board. The capacity of the batteries and the power of the solar panel should be enlarged if you want to use more. You can connect the solar panel and the solar charge controller refers to the following illustration.

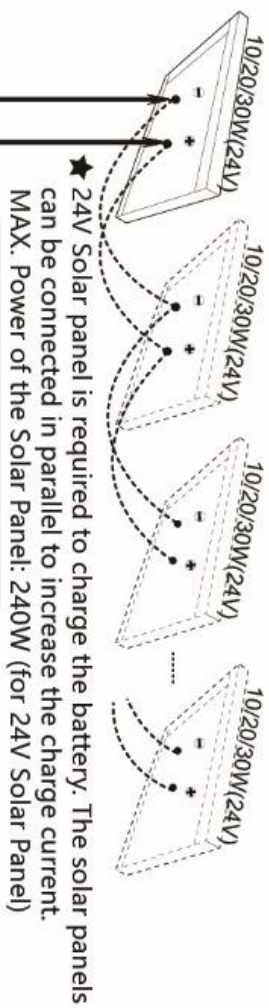

★ Require 2PCS 12V batteries to be connected in series to become 24V

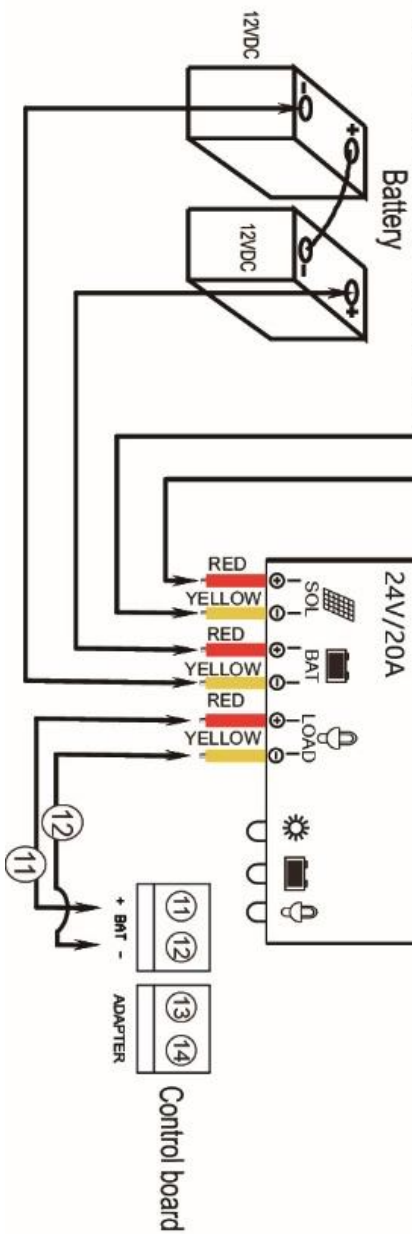

Connection of the control board

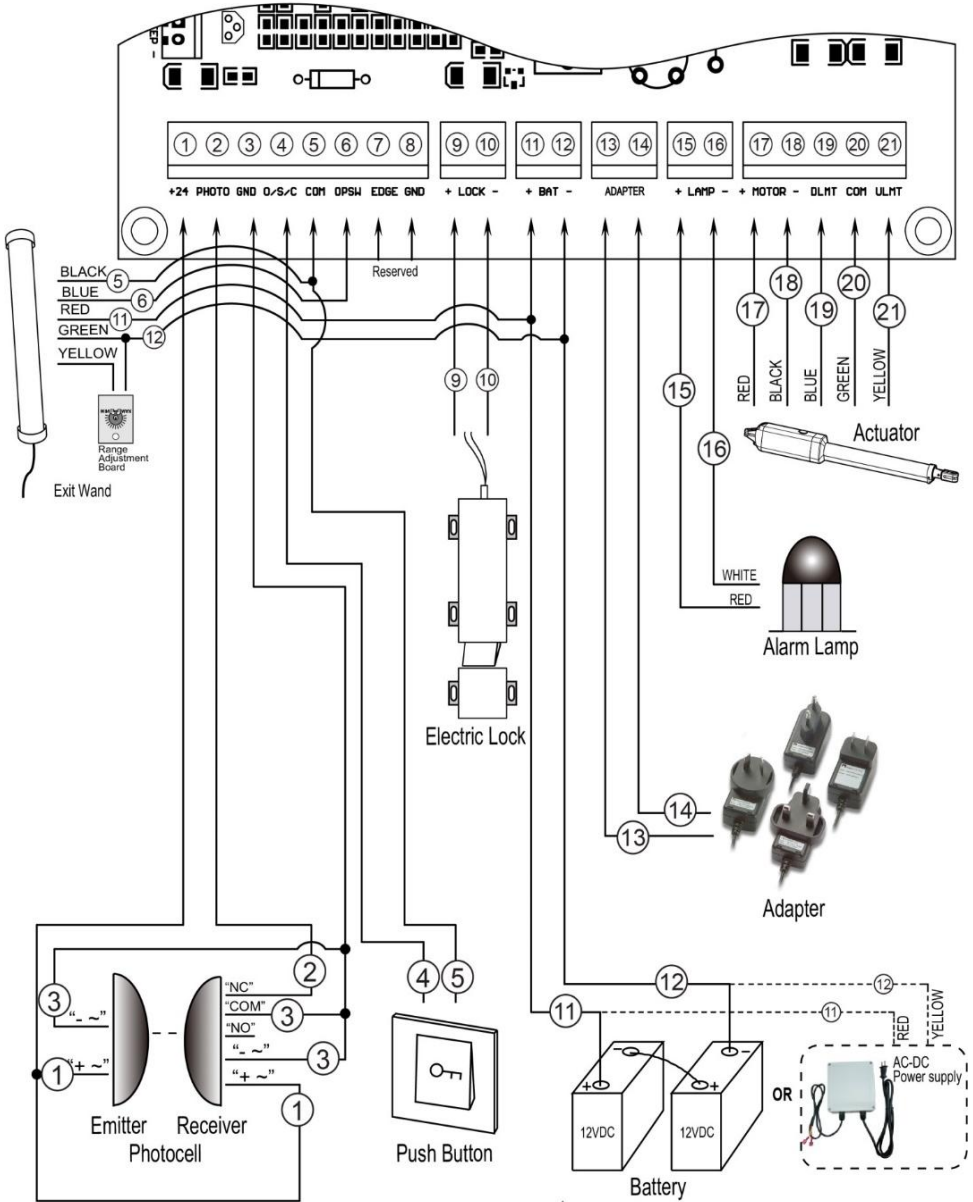

⚠ Important Note:

This gate opener can be powered by 24V 12Ah battery (NOT INCLUDED) OR DPS180-U AC-DC Power Supply (NOT INCLUDED). The adapter included in the package is ONLY used to charge the battery. The AC-DC Power Supply is highly recommended as the power source to save the cost where AC electricity is accessible and stable.

★ 2PCS 12V batteries can be connected in series to become 24V

1. Actuator

Insert the stripped cable wires into the appropriate terminals on the opener terminals block. The **red** wire should be inserted into the “**+MOTOR**” terminal (#17), the **black** wire into “**MOTOR-**” terminal (#18), the **blue** wire into “**DLMT**” terminal (#19), the **green** wire into “**COM**” terminal (#20), and the **yellow** wire into “**ULMT**” terminal (#21).

2. Battery (Required but not included)

The “**24V+**” of the battery should be wired to the **+BAT** (#11) terminal, “**24V-**” should be wired to “**BAT-**” (#12) terminal. 2*12VDC batteries can be connected in series to become 24V.

3. Adapter (Only used to charge the batteries)

Insert the stripped cable wires into **ADAPTER** (#13) terminals to the control board. No matter the polarity.

4. Alarm Lamp (Warning Light, optional)

The red wire of the alarm lamp should be inserted into either **LAMP** (#15) terminal, the white wire into the other one (#16).

5. Photocell Beam System (PBS) (optional)

Use a 2-core cable to connect the “**+ ~**” terminal of the photocell’s emitter to the “**+24**”(#1) terminal, the “**- ~**” terminal to the “**GND**”(#3) terminal. Also the “**+ ~**” and “**- ~**” terminals of the photocell’s receiver should be connected to the “**+24**” and “**GND**” terminals in parallel.

Use another 2-core cable to connect the “**NC**” terminal of the receiver to the “**PHOTO**”(#2) terminal, the “**COM**” terminal to the “**GND**”(#3) terminal.

6. Push Button (optional)

The push button should be wired to the “**#4** and “**#5**” terminals. No matter the polarity. The gate operator works alternately by pressing the button (open-stop-close-stop-open).

7. Electric Lock (optional)

The electric lock should be wired to the “**+LOCK-**” terminal (“**#9** and “**#10**” terminals), no matter the polarity of the wires.

8. Exit Wand (optional)

The **BLACK** wire of the exit wand should be connected into the “**#5**” terminal.

The **BLUE** wire of the exit wand should be connected into the “**#6**”

terminal.

The **RED** wire of the exit wand should be connected into the “#11” terminal.
The **GREEN** wire of the exit wand should be connected into the “#12” terminal.

The sensitivity adjustment board should be wired to the **GREEN** wire and the **YELLOW** wire of the wand. No matter the polarity.

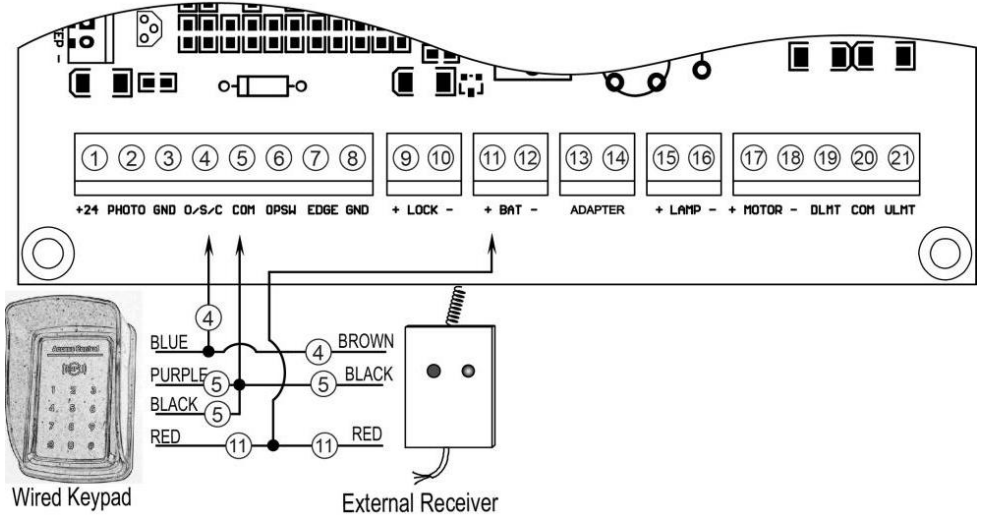

9. Wired Keypad (optional)

The **RED** wire of the wired keypad should be connected into the “#11” terminal.

The **BLACK** wire of the wired keypad should be connected into the “#5” terminal.

The **PURPLE** wire of the wired keypad should be connected into the “#5” terminal.

The **BLUE** wire of the wired keypad should be connected into the “#4” terminal.

10. External receiver (optional)

The **RED** wire of the external receiver should be connected into the “#11” terminal.

The **BLACK** wire of the external receiver should be connected into the “#5” terminal.

The **BROWN** wire of the external receiver should be connected into the “#4” terminal.

terminal.

Note: Using of the exit wand, keypad and external receiver would cause the battery exhausted quickly. Big capacity of battery and big power of solar panel (if the solar panel is used as main charger) is required if you want to use either of them.

How to Program the Remote to the Opener

You must program the remote to the opener before operating. You can follow the below steps to program the remote to the opener.

Press and release the **CODE SW** button, the **CODE LED** will be ON, then press the key in the remote twice in 4 seconds, the **CODE LED** will flash for 3 seconds and then to OFF. Now the remote has been programmed successfully.

NOTE: The button of the remote control should be pressed and hold for more than 2 seconds while programming. Max. 10 remotes can be programmed for the opener. If you want program more remotes, you should use an optional external receiver.

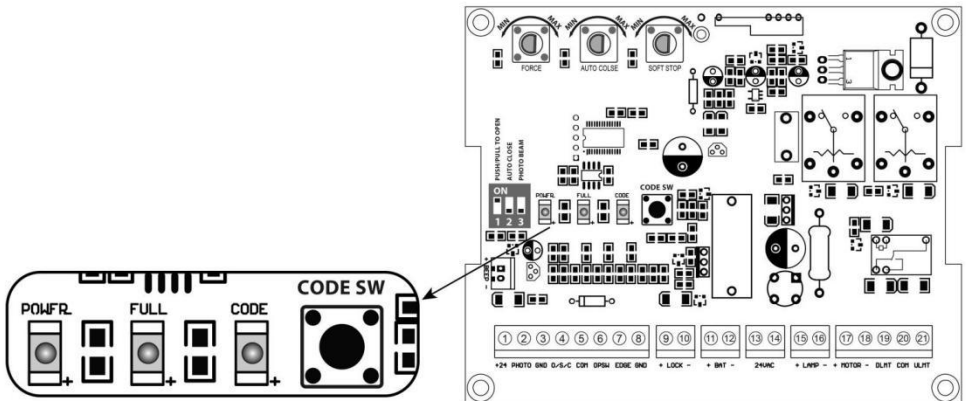

How to use the remote to operate your gate opener

Each remote has four buttons, they are A, B, C and D. You may use this remote to operate as many as 4 sets our swing gate opener or 1 set our sliding gate opener and 2 sets our swing gate opener.

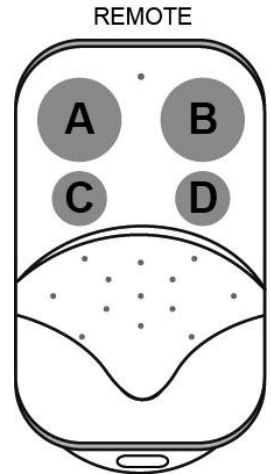

1. Use this remote to only operate swing gate opener A, B, C and D four buttons share same function once they are programmed with our swing gate opener. You may choose any button to program it with our swing gate opener. Every press of the button is able to active the gate opener to work alternately (open-stop-close-stop-open).

2. Use one remote to operate swing gate opener & sliding gate opener at the same time. All of our sliding gate opener have midway mode. B is designed to realize midway function (refer to more details in our sliding gate opener manual). So, it is must program A button with sliding gate opener, while you may program either C button or D button with swing gate opener.

Wireless keypad programming

You can follow the below steps to program wireless keypad to the opener. Press the **CODE SW** button until the **CODE LED** is ON, then release the button. Then press "OK" button on keypad and **CODE LED** will flash for 3 seconds and then be OFF which indicates the keypad has been programmed successfully. You can use the default password "888888" to operate the opener after programming. You can press "PIN" "8 8 8 8 8 8" and then press "OK" to confirm to operate the opener.

Also, you can change the password of the keypad follow the below steps. Press "PIN" and then input the six digits old password and then press "PIN" again, the **CODE LED** will be ON. Input the six digits new password and then press the "PIN" to confirm the new setting, **CODE LED** will flash for 3

seconds and then be OFF which indicates the password has been changed successfully. You can press “PIN” “6 digits new password” and then press “OK” to confirm to operate the opener.



Wireless Keypad

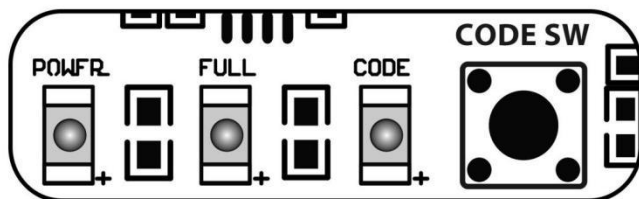

NOTE: Every step for pressing button during program must be finished within 1 second to ensure successful programming.

Adjusting the Limit Switch

Note: Before adjusting the limit switch, refer to the chapter of “Install the Opener on the Gate”, and make sure that the rod is fully retracted when the gate is in the fully open position (for Pull-to-Open installation), or in the fully closed position (for Push-to-Open installation). Make sure that currently the rod is fully retracted.

Note: The position of Limit Switch A was fixed in factory, do not adjust it again.

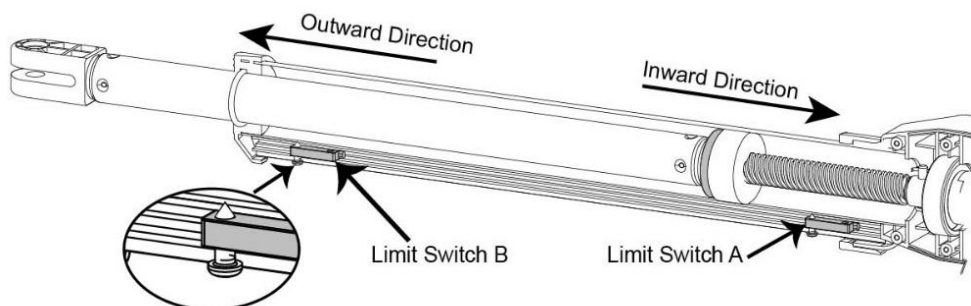

Screw for Fixing Limit Switch B

1. For Pull-to-Open Installation, adjust the limit switch B to determine

the closed position:

Turn on power to operate the gate opener, then the arm extends to close the gate.

If the arm closes over the desired closed position, press the remote control to stop the opener. Use a screwdriver to loosen the screw of the limit B, slightly slide the limit switch B **inwards**.

If the arm closes halfway and fails to get to the desired closed position, slightly slide the limit switch B **outwards**.

Please **repeat** the above steps, until the arm could arrive and automatically stop at the desired close position. Then tighten the screw firmly.

Limit setting is finished now.

2. For Push-to-Open Installation, adjust the limit switch B to determine the open position:

Turn on power to operate the gate opener, then the arm extends to open the gate.

If the arm opens over the desired open position, press the remote control to stop the opener. Use a screwdriver to loosen the screw of the limit B, slightly slide the limit switch B **inwards**.

If the arm opens halfway and fails to get to the desired open position, slightly slide the limit switch B **outwards**.

Please **repeat** the above steps, until the arm could arrive and automatically stop at the desired open position. Then tighten the screw firmly.

Limit setting is finished now.

Setting of the Control Board

 **WARNING:** Ensure the gate opener is Power Off when you make any adjustment of the gate opener. Keep away from the gate during you set the gate opener system in case of the unexpected gate moving. Carefully adjust the DIP switches to avoid the risk of machine damage and injury or death. Always ask the help of professional technician /electrician if you have any question.

1. DIP Switches

The DIP switches are used to select pull/push to open, enable/disable auto

close function, enable/disable photocell function.

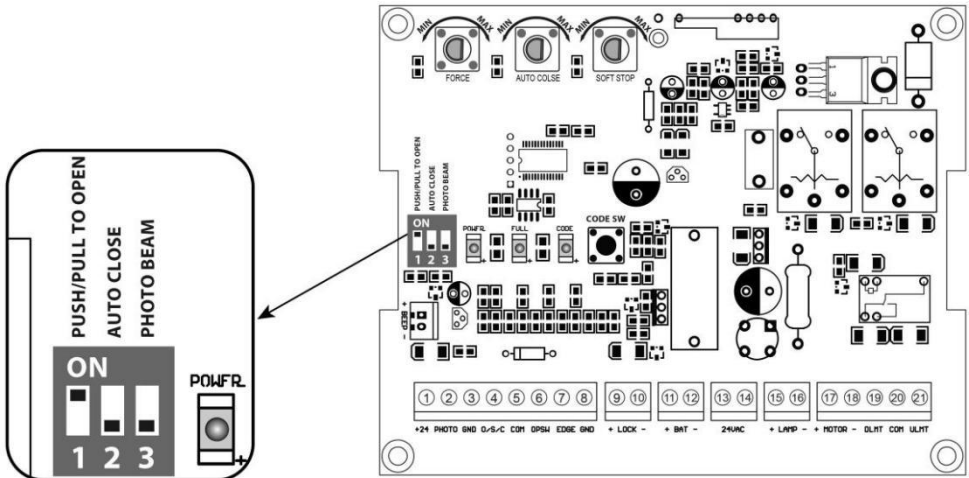

DIP Switch #1: Select push/pull to open

If the gate opens into the property (**pull to open**), the DIP Switch is set to **OFF** (factory default setting). If your gate opens out from the property (**push to open**) the DIP Switch must be set to the **ON** position. Factory default setting is **OFF**.

DIP Switch #2: Auto close function enabled/disabled

- ON** – Auto close function **enabled**
- OFF** – Auto close function **disabled**

Set the switch #2 to ON to enable the auto close function. Factory default setting is **OFF**.

DIP Switch #3: Photocell function enabled/disabled

- ON** – Photocell function **enabled**
- OFF** – Photocell function **disabled**

You must set the switch #3 to ON to enable the photocell function if you want to use the photocell with the gate opener. Factory default setting is **OFF**.

2. Potentiometers

There are 3 potentiometers located in the control board. They are used to adjust the stall force, auto-close time and soft stop period.

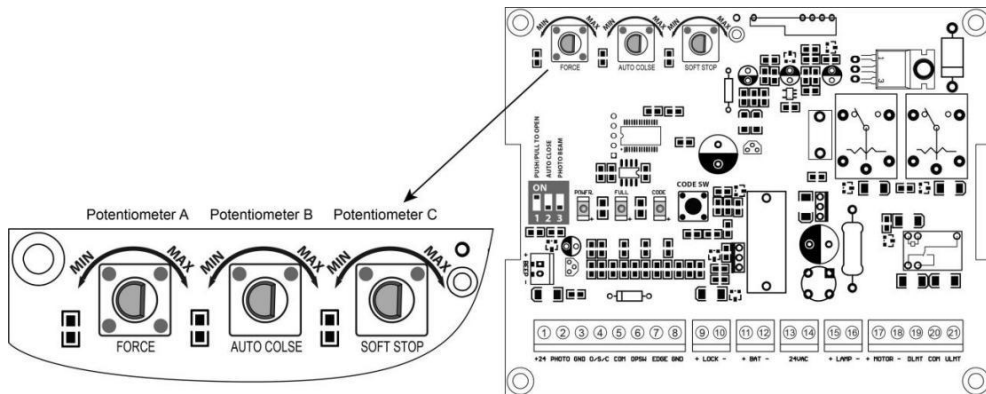

Potentiometer A is used to adjust the stall force the gate opener. Turn the potentiometer clockwise to increase the stall force, and turn it counter-clockwise to decrease the stall force.

Potentiometer B is used to adjust the auto close time of the gate opener. Turn the potentiometer clockwise to increase the auto close time, and turn it counter-clockwise to decrease the auto close time. The auto close time can be adjusted stepless from 3 to 120 seconds.

Potentiometer C is used to adjust the soft stop period of the gate opener. Turn the potentiometer clockwise to increase the soft stop period, and turn it counter-clockwise to decrease the soft stop period. The soft stop time can be adjusted stepless from 1 to 5 seconds.

Trouble Shooting

Have a multimeter to check voltage and continuity. Use caution when checking high voltage terminals.

Symptom	Possible Solution(s)
The opener does not run. Only the CODE LED is ON slightly.	1. The batteries are not connected to the control board or the wire connection of the batteries is loosened. Please note that a 2*12V batteries is required to power up the gate opener. The Adapter which is included in the package is only used to charge the batteries.
The opener does not	1. Battery is over-discharge. Check the voltage of the battery. The

<p>run. Power LED flash rapidly (the LED is ON 200ms per second, normally the LED ON 500ms per second).</p>	<p>voltage of the battery should above 22V to make the gate opener work normally.</p>
<p>The opener does not run. Power LED does not ON.</p>	<ol style="list-style-type: none"> 1. Make sure the connection between the battery and control board is correct and fastening. 2. Check the fuse in the control board. Replace the fuse if it was burnt out. 3. Check the control board. Replace the control board if necessary.
<p>Gate moves a little and then reverse or stop</p>	<ol style="list-style-type: none"> 1. The selected force is too small to move the gate. Turn the Potentiometer A clock-wise to increase the force. 2. Disconnect the gate from the gate operator and check that the gate slides freely without any binding.
<p>Gate opener does not run when you press the remote control</p>	<ol style="list-style-type: none"> 1. Make sure the remote has been programmed to the control board before using. 2. The battery of the remote may be exhausted. Replace the battery and try it again. 3. Check the control board. Replace the control board if necessary.
<p>Gate can open but does not close</p>	<ol style="list-style-type: none"> 1. Make sure the connection of the photocell beam is not blocked if the photocell is used. 2. Check if the close limit switch is broken. 3. Check the control board. Replace the control board if necessary.
<p>Gate automatically opens, but does not automatically close</p>	<ol style="list-style-type: none"> 1. Setting of DIP switch #1 would be wrong. Please set the dip switch correctly according to the push/pull to opener installation of the gate opener.



According to Waste of Electrical and Electronic Equipment (WEEE) directive, WEEE should be separately collected and treated. If at any time in future you need to dispose of this product please do NOT dispose of this product with household waste. Please send this product to WEEE collecting points where available.

Manufacturer:Shanghaimuxinmuyeyouxiangongsi

Address: Shuangchenglu 803nong11hao1602A-1609shi, baoshanqu, shanghai 200000 CN.

Imported to AUS: SIHAO PTY LTD. 1 ROKEVA STREETEASTWOOD NSW 2122 Australia

Imported to USA: Sanven Technology Ltd. Suite 250, 9166 Anaheim Place, Rancho Cucamonga, CA 91730

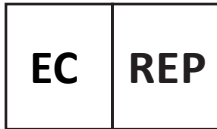

E-CrossStu GmbH
Mainzer Landstr.69, 60329 Frankfurt am Main.



YH CONSULTING LIMITED.
C/O YH Consulting Limited Office 147, Centurion House,
London Road, Staines-upon-Thames, Surrey, TW18 4AX

VEVOR[®]
TOUGH TOOLS, HALF PRICE

Technical Support and E-Warranty Certificate
www.vevor.com/support