

# **VEVOR<sup>®</sup>**

**TOUGH TOOLS, HALF PRICE**

Technical Support and E-Warranty Certificate [www.vevor.com/support](http://www.vevor.com/support)

## **TILLER CULTIVATOR**

### **USER MANUAL**

We continue to be committed to provide you tools with competitive price.

"Save Half", "Half Price" or any other similar expressions used by us only represents an estimate of savings you might benefit from buying certain tools with us compared to the major top brands and does not necessarily mean to cover all categories of tools offered by us. You are kindly reminded to verify carefully when you are placing an order with us if you are actually saving half in comparison with the top major brands.

# VEVOR<sup>®</sup>

TOUGH TOOLS, HALF PRICE

TILLER CULTIVATOR

SRHX-50



## NEED HELP? CONTACT US!

Have product questions? Need technical support? Please feel free to contact us:

**Technical Support and E-Warranty Certificate**  
**[www.vevor.com/support](http://www.vevor.com/support)**

This is the original instruction, please read all manual instructions carefully before operating. VEVOR reserves a clear interpretation of our user manual. The appearance of the product shall be subject to the product you received. Please forgive us that we won't inform you again if there are any technology or software updates on our product.

# SAFETY

## OWNER'S RESPONSIBILITY

Accurate assembly and safe and effective use of the rototiller is the owner's responsibility.

- Read and follow all safety instructions.
- Carefully follow all assembly instructions.
- Maintain the tiller according to directions and schedule included in the operator's manual.
- Ensure that anyone who uses the tiller is familiar with all controls and safety precautions.

## SPECIAL MESSAGES

Your manual contains special messages to bring attention to potential safety concerns, machine damage as well as helpful operating and servicing information. Please read all the information carefully to avoid injury and machine damage.

***NOTE: General information is given throughout the manual that may help the operator in the operation or service of the machine.***

## IMPORTANT SAFETY PRECAUTIONS

**Please read this section carefully.**

Operate the tiller according to the safety instructions and recommendations outlined here and inserted throughout the text. Anyone who uses this tiller must read the instructions and be familiar with the controls. Your tiller is equipped with a

## DANGER

DANGER INDICATES A SERIOUS INJURY OR FATALITY WILL RESULT IF THE SAFETY INSTRUCTIONS THAT FOLLOW THIS SIGNAL WORD ARE NOT OBEYED.

## DANGER

WARNING INDICATES A SERIOUS INJURY OR FATALITY COULD RESULT IF THE SAFETY INSTRUCTIONS THAT FOLLOW THIS SIGNAL WORD ARE NOT OBEYED.

## CAUTION

CAUTION INDICATES YOU CAN OR YOUR EQUIPMENT CAN BE HURT IF THE SAFETY INSTRUCTIONS THAT FOLLOW THIS SIGNAL WORD ARE NOT OBEYED.

## IMPORTANT

IMPORTANT INDICATES HELPFUL INFORMATION FOR PROPER ASSEMBLY, OPERATION, OR MAINTENANCE OF YOUR EQUIPMENT.

## IMPORTANT

YOU MUST READ, UNDERSTAND AND COMPLY WITH ALL SAFETY AND OPERATING INSTRUCTIONS IN THIS MANUAL BEFORE ATTEMPTING TO SETUP AND OPERATE YOUR ROTO TILLER. FAILURE TO COMPLY WITH ALL SAFETY AND OPERATING INSTRUCTIONS CAN RESULT IN LOSS OF MACHINE CONTROL, SERIOUS PERSONAL INJURY TO YOU AND/OR BYSTANDERS, AND RISK OF EQUIPMENT AND PROPERTY DAMAGE. THE TRIANGLE IN THE TEXT SIGNIFIES IMPORTANT CAUTIONS OR WARNINGS WHICH MUST BE FOLLOWED.

safety device that enables you to stop the wheels and tines quickly in an emergency. Learn how the drive safety control lever operates and how to control the tiller at all times.

**YOU MUST READ, UNDERSTAND AND COMPLY WITH ALL SAFETY AND OPERATING INSTRUCTIONS IN THIS MANUAL BEFORE ATTEMPTING TO SETUP AND OPERATE YOUR ROTO TILLER.**



**This symbol points out important safety instructions which if not followed could endanger your personal safety. Read and follow all instructions in this manual before attempting to operate this equipment.**

- Do not allow children to operate this rototiller. Keep small children away from the area being tilled. Do not allow adults to operate the tiller without proper instruction.

## **PREPARATION**

- Dress appropriately when operating the tiller. Always wear sturdy footwear. Never wear sandals, sneakers, or open shoes, and never operate the tiller with bare feet. Do not wear loose clothing that might get caught in moving parts.
- Carefully inspect the area to be tilled and remove all foreign objects. Do not till above underground water lines, gas lines, electric cables, or pipes. Do not operate the tiller in soil with large rocks and foreign objects which can damage the equipment.
- Disengage all clutches and leave all control levers in the neutral position before starting the engine.
- Handle fuel with care; it is highly flammable.
  - a. Use an approved fuel container.
  - b. Never add fuel to a running engine or hot engine.
  - c. Fill fuel tank outdoors with extreme care. Never fill fuel tank indoors.
  - d. Replace gasoline cap securely and clean up spilled fuel before restarting.
- Never attempt to make any adjustments while the engine is running.

## **OPERATION**

- Never operate the tiller without guards, covers, and hoods in place.
- Never start the engine or operate the tiller with the wheels in the free-wheel position. Make sure the wheel lock pins are engaged through the wheel hubs and wheel axle. The wheels act as a brake to keep the tiller at a controlled speed. Disengage wheel lock pins to permit free-wheeling only when engine is stopped.

- Keep hands, feet, and clothing away from rotating parts. Keep clear of tiller tines at all times.
- Tines and wheels rotate when tiller is engaged in **forward**. Grip the clutch on the left side, tines and wheels rotate and the tiller move forward. Grip the clutch on the right side, wheels rotate but tines do not rotate and the tiller move reverse. Releasing the both clutch handle to the **neutral** position stops the wheels and tines.

**Warnings: Do not operate both left and right clutch handle at the same time.**

- Be extremely cautious when operating in **reverse**. Take extra care to avoid slipping or falling, and keep hands and feet clear of tines.

**• Use extreme caution when operating on or crossing gravel drives, walks, or roads. Stay alert for hidden hazards or traffic.**

- After striking a foreign object, stop the engine, remove the wire from the spark plug, thoroughly inspect the tiller for any damage, and repair the damage before restarting and operating the tiller.
- If vegetation clogs the tines, raise the handlebars to elevate the tines, and run the tiller in **reverse**. If this does not clean clogged vegetation from the tines, **STOP THE ENGINE AND DISCONNECT THE SPARK PLUG WIRE** before removing vegetation by hand.
- Engine muffler will be hot from operation. Do not touch it with bare skin or a severe burn may result.
- If the unit should start to vibrate abnormally, stop the engine and check immediately for the cause. Vibration is generally a warning of trouble.
- Do not run the engine indoors; exhaust fumes are deadly.
- **Do not overload the machine capacity by attempting to till too deep at a fast rate.**
- Never operate the machine at high transport speeds on slippery surfaces. Look behind and use care when backing.

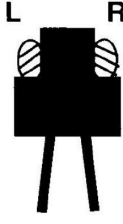
<p><b>IMPORTANT</b>          THE RIGHT AND LEFT SIDES OF YOUR ROTO TILLER ARE DETERMINED FROM THE OPERATING POSITION AS YOU FACE THE DIRECTION OF FORWARD TRAVEL.          ENGINE IS SHIPPED FROM FACTORY WITHOUT OIL. YOU MUST ADD ENGINE OIL BEFORE STARTING ENGINE.</p>	
--	--

- Never allow bystanders near the unit.
- Use only attachments and accessories approved by the manufacturer of the tiller.
- Never operate the tiller without good visibility or light.
- Be careful when tilling in hard ground. The tines may catch in the ground and propel the tiller backward. If this occurs, let go of the handlebars and do not restrain the machine.
- Take all possible precautions when leaving the machine unattended. Disengage all control levers, stop the engine, wait for all moving parts to stop, and make certain guards and shields are in place.
- When leaving the operating position for any reason:
  - shut off the engine.
  - wait for all moving parts to stop.

## **MAINTENANCE AND STORAGE**

- Keep machine, attachments, and accessories in safe working condition.
- Check shear bolts, engine mounting bolts, and other bolts at frequent intervals for proper tightness to be sure the equipment is in safe working condition.
- To prevent accidental starting, always disconnect and secure the spark plug wire from the spark plug before performing tiller maintenance.
- Never run the engine indoors. Exhaust fumes are deadly.
- Always allow muffler to cool before filling fuel tank.
- Never store equipment with gasoline in the tank inside a closed building where fumes may reach an open flame or spark. Allow the engine to cool before storing it in any building.
- Always refer to the operator's guide instructions for important details if the tiller is to be stored for an extended period.

## **SAFETY DECALS**

This rototiller unit has been designed and manufactured to provide you with the safety and reliability you would expect from an industry leader in outdoor power equipment manufacturing.

Although reading this manual and the safety instructions it contains will provide you with the necessary basic knowledge to operate this equipment safely and effectively, we have placed several safety labels on the tiller to remind you of this important information while you are operating the unit.

These important safety labels are illustrated below, and are shown here to help familiarize you with the location and content of the safety messages you will see as you perform normal tilling operations. Please review these labels now. If you have any questions regarding their meaning or how to comply with these instructions, reread the complete safety instruction text on the preceding pages, or contact your local dealer.

If any of the safety labels become unreadable because of being worn, faded, or otherwise damaged during the use of your tiller, please use the part number information provided to order a replacement label from your local authorized dealer.

The safety labels are easily applied, and will act as a constant visual reminder to you and others who may use the equipment. Follow the safety instructions necessary for safe, effective operation of your rototiller.

## **WARNING**

### **AVOID SERIOUS INJURY**

- Read operator's manual(s) before operating.
- Know the location and function of all controls.
- Keep all shields and guards in place and working while running.
- Never allow children to operate tiller.
- Dress appropriately—wear sturdy footwear.
- Carefully inspect area to be tilled—remove large rocks and other foreign objects.
- DO NOT till above underground electric, water, gas, or other utility lines and pipes.
- STOP THE ENGINE AND DISCONNECT THE SPARK PLUG WIRE before removing debris or servicing unit.
- When leaving the operating position for any reason:
  - shut off the engine.
  - wait for all moving parts to stop.

## **WARNING**

### **WHEELS ACT AS BRAKES**

- Never start or operate tiller with wheels in the Free Wheel position, Make sure wheel lockouts are engaged through wheel hubs and axle.
- Wheels act as brakes to keep the tiller at a controlled speed, Disengage wheel lockouts ONLY when engine is stopped.

## **OPERATION**

**REFER TO OPERATOR'S MANUAL FOR DETAILED OPERATING INSTRUCTIONS TO START:**

1. Release drive control levers to neutral position.
2. Lower the drag stake so that tines do not touch the ground.
3. Check position of wheels and wheel lockouts.
4. Slide choke control to choke position.
5. Move throttle control lever to fast position.
6. Pull starter rope.

# ASSEMBLY INSTRUCTIONS

The rototiller comes fully assembled except for a few parts. The following instructions will help you assemble and adjust the tiller's depth regulator, cable tension, and handlebar height. You will need two 9/16" wrenches to complete the assembly.

## IMPORTANT

THE RIGHT AND LEFT SIDES OF YOUR ROTOTILLER ARE DETERMINED FROM THE OPERATING POSITION AS YOU FACE THE DIRECTION OF FORWARD TRAVEL.

ENGINE IS SHIPPED FROM FACTORY WITHOUT OIL. YOU MUST ADD ENGINE OIL BEFORE STARTING ENGINE.

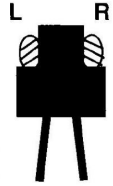

## STEP 1 Install the Depth Regulator

1. Install the depth regulator into the top of the depth regulator Bracket with handle facing rearward.
2. Insert depth regulator pin through depth regulator bracket and top hole of depth regulator tines should clear the ground.

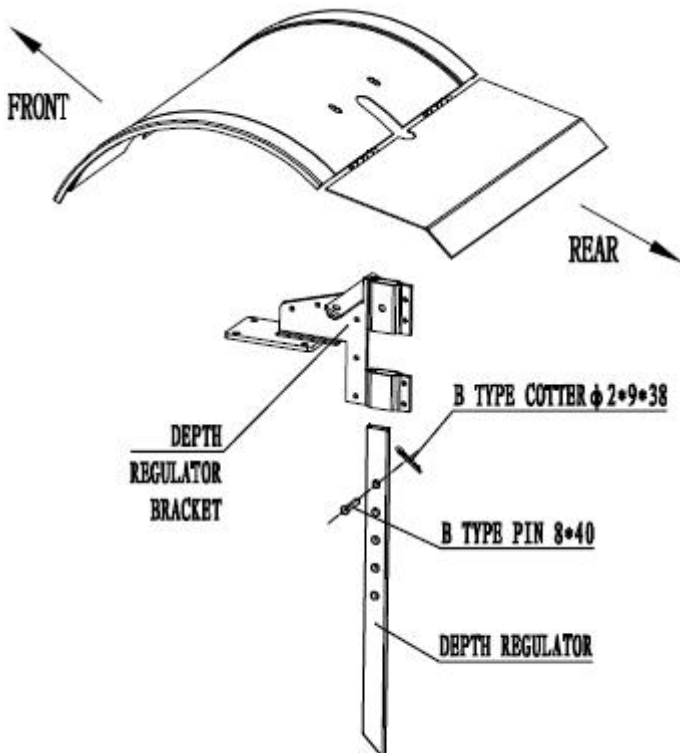



## STEP 2 Attach ex-arm-rest stems to the Tiller

1. The ex-arm-rest stems on outside of the Transmission cover and align the lower boles.
2. Insert one 3/8"-16x 1" bolt for each side in lower holes.
3. Start 3/8"-16 nuts on each bolt.
4. Insert one 3/8"-16x 1" bolt for each side in Upper holes at desired handlebar height.
5. Tighten all the nuts.

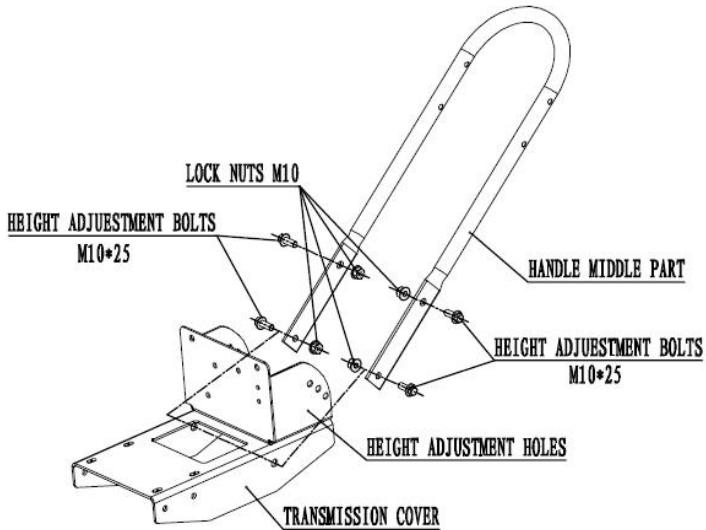

## STEP 3: Attach handle bar to the Tiller

1. Insert four fastness bolts for each side in every holes.
2. Start fastness nuts on each bolt.
3. Tighten all the nuts.

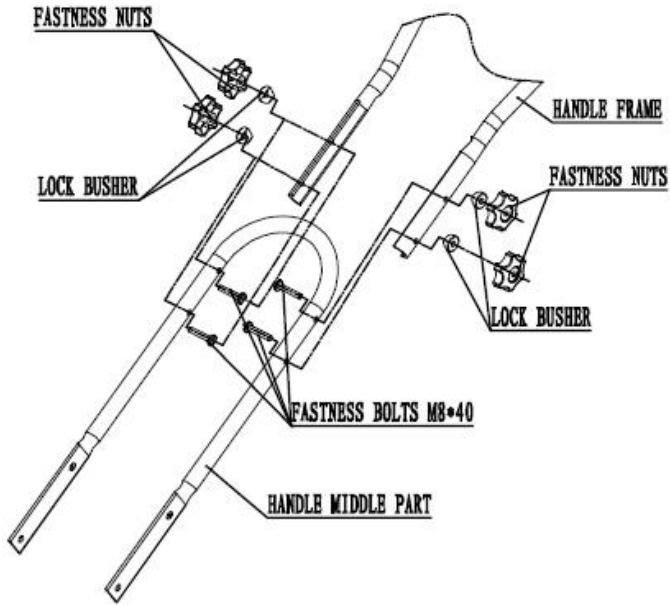

## STEP4 Fill Engine Crankcase

### IMPORTANT

Engine is shipped from factory without oil. Engine oil must be added before starting engine.

1. Add oil according to engine manual. Do not overfill. Use clean, high quality detergent oils. Do not mix oil with gasoline. Oil level must be full. Check the oil level by removing oil fill plug.

2. Always check oil level before starting engine. Refer to engine manual for capacity and type of oil to use.

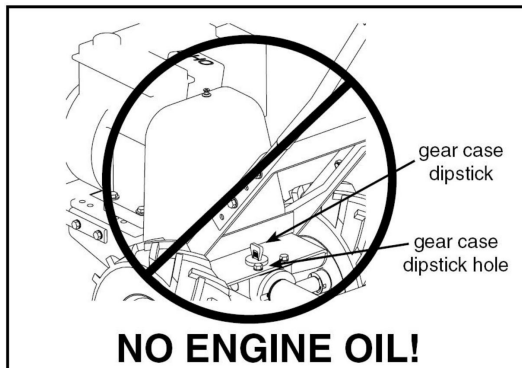

# OPERATION

## PRE-START INSPECTION

1. Make sure all safety guards are in place and all nuts and bolts are secure.
2. Check oil level in engine crankcase. See your engine manual for procedure and specifications.
3. Inspect air cleaner for cleanliness. See your engine manual for procedure.
4. Check the fuel supply. Fill the fuel tank no closer than 1 inch from top of tank to provide space for expansion. See your engine manual for fuel recommendations.
5. Be sure spark plug wire is attached and spark plug is tightened securely.
6. Check the position of wheels and wheel lockouts.
7. Check depth regulator lever position.
8. Examine underneath and around engine for signs of oil or fuel leaks.
9. Inspect fuel hoses for tightness and fuel seepage.
10. Look for signs of engine damage.
11. Remove excessive debris from muffler area and recoil starter.

## START- UP

The controls required to start and run the rototiller are located on the engine and are marked “choke” and “Throttle”.

A more detailed description of engine operation and all related precautions and procedures can be found in the engine manual that accompanies each tiller.

### CAUTION

PLEASE DO NOT START YOUR TILLER UNTIL YOU HAVE READ THE MANUAL THAT CAME WITH YOUR ENGINE, AND THE SECTIONS IN THIS MANUAL TITLED CONTROLS, ADJUSTMENTS AND SAFETY. IF YOU HAVE READ THESE, FOLLOW THE STEPS BELOW TO START YOUR TILLER. ALWAYS PERFORM THIS PRE-START CHECKLIST BEFORE STARTING THE ENGINE.

### WARNING

GASOLINE IS HIGHLY FLAMMABLE AND MUST BE HANDLED WITH CARE. NEVER FILL THE TANK WHEN THE ENGINE IS HOT OR RUNNING. ALWAYS MOVE OUTDOORS TO FILL THE TANK.

WHEELS MUST ALWAYS BE LOCKED IN THE TILLING POSITION WHEN ENGINE IS RUNNING. DO NOT OPERATE THE TILLER WITH THE WHEEL LOCKOUTS UNLOCKED. ALWAYS SET THE WHEELS IN TILLING POSITION BEFORE STARTING ENGINE.

ALWAYS PUT THE DEPTH REGULATOR LEVER IN THE TRANSPORT POSITION BEFORE STARTING ENGINE. TINES SHOULD CLEAR THE GROUND.







### IMPORTANT





ENGINE IS SHIPPED FROM FACTORY WITHOUT OIL. YOU MUST ADD ENGINE OIL BEFORE STARTING ENGINE.

### DANGER

ALWAYS KEEP HANDS AND FEET CLEAR OF ROTATING MACHINE PARTS.

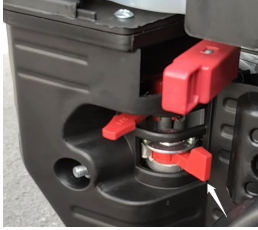
## COLD STARTS

1	 	Fill engine oil (≅ 0.6L)
2		Fill drive shaft oil (≅ 0.7L)
3	 	Gasoline filling (≅ 3.6L)
4		Turn the stop switch “ON” on the left handle.
5	 	Turn up the throttle control valve.

6		Open the throttle.
7		Set damper to closed position.
8		Pull the rope to start the engine.
9		Close the damper.
10		Press the yellow protection switch first, and then press the red to start the forward gear (the wheel goes forward; The tool head starts to rotate).

11		<p>Start reverse gear (wheel reverse; Tool head stop rotating).</p>
----	--	---

## **RESTARTING A WARM ENGINE**

Restarting an engine that is already warm from previous running does not normally require use of the choke.

1. Move throttle lever to “start” position.
2. Pull starting rope out rapidly until engine starts. Allow rope to return normally. Repeat until engine starts.
3. Adjust throttle speed to “high” for best tiller action.

## **IDLE SPEED**

Use the “low” position on the throttle lever to reduce stress on the engine when tilling is not being performed. Lowering the engine speed to “idle” will help extend the life of the motor, as well as conserve fuel and reduce the noise level of the equipment.

## **OPERATING SPEED**

For normal tilling, set the throttle lever to “fast”.

## **SHUTTING DOWN**

To stop the engine at any time, turn engine ON/OFF switch to the off position. To stop wheels and tines at any time, release drive safety control levers to neutral position.

## **TILLING**

1. Adjust the depth regulator lever to desired tilling depth.

### **⚠ WARNING**

TEMPERATURE OF MUFFLER AND NEARBY AREAS MAY EXCEED 150° F. AVOID THESE AREAS.

DO NOT MOVE CHOKE CONTROL TO CHOKE TO STOP ENGINE. BACKFIRE OR ENGINE DAMAGE MAY OCCUR.

TO STOP WHEELS AND TINES AT ANY TIME, RELEASE DRIVE SAFETY CONTROL LEVERS TO NEUTRAL POSITION.

ALWAYS RELEASE DRIVE SAFETY CONTROL LEVERS TO NEUTRAL POSITION BEFORE ADJUSTING THE DEPTH OF THE REGULATOR LEVER.

### **⚠ DANGER**

ENGINE AND SURROUNDING PARTS BECOME EXTREMELY HOT DURING NORMAL USE AND WILL CAUSE SERIOUS BURN INJURIES IF TOUCHED BEFORE THE ENGINE HAS COOLED.

ALLOW ENGINE TO COOL COMPLETELY BEFORE TOUCHING THESE HOT SURFACES.

### **IMPORTANT**

PRACTICE OPERATING THE CONTROLS AND TILLER WITH TINES OUT OF GROUND BEFORE BEGINNING TO TILL. IT IS IMPORTANT THAT YOU KNOW HOW TO USE THE TILLER PROPERLY, KEEP CONTROL AT ALL TIMES, STOP THE TINES AND WHEELS FROM TURNING, AND STOP THE ENGINE IF NECESSARY. IF YOU DO NOT KNOW HOW TO DO THESE THINGS, READ THE CONTROLS, ADJUSTMENTS AND SAFETY SECTIONS BEFORE PROCEEDING.

**NOTE: Raise depth regulator lever up one hole at a time, testing tiller operation after each raise. Raising depth regulator lever too high can result in loss of control of tiller!**

2. Move the throttle control to **fast**.

3. Place the tiller in **forward** by pushing down on the drive safety control lever(**FORWARD**)--this will engage the wheels and tines.

**NOTE: You can slow the tiller's forward advance at any time by putting slight downward pressure on the handlebars. You can stop the tiller by releasing the drive safety control levers to the neutral position.**

## DRIVE SAFETY CONTROL LEVERS

### FORWARD LEVER

*Engages wheels and tines into forward.*

Pushing down the drive safety control lever(**FORWARD**) toward the handlebar engages the wheels and tines. Releasing the lever stops the wheels and tines and brings the tiller to a complete stop.

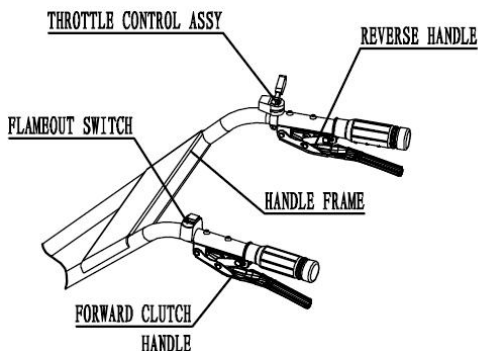

### **⚠ CAUTION**

DO NOT OPERATE BOTH "FORWARD" AND "REVERSE" DRIVE SAFETY CONTROL LEVERS AT THE SAME TIME.

THIS INFORMATION IS PROVIDED HERE ONLY TO INTRODUCE THE CONTROLS. DO NOT START THE ENGINE AT THIS TIME. STARTING AND OPERATING INSTRUCTIONS ARE GIVEN ON PAGE ???. PLEASE READ THIS SECTION AND ALL OPERATING AND SAFETY INSTRUCTIONS BEFORE STARTING YOUR TILLER.

- AS A SAFETY PRECAUTION, THE DRIVE SAFETY CONTROL LEVERS WILL NOT LOCK IN THE FORWARD OR REVERSE POSITION.
- AS A SAFETY PRECAUTION, THE REVERSE DRIVE SAFETY CONTROL LEVER WILL NOT LOCK IN REVERSE.
- TO STOP THE WHEELS AND TINES AT ANY TIME RELEASE THE DRIVE SAFETY CONTROL LEVERS OR RELEASE THE REVERSE HANDLE.
- DO NOT OPERATE BOTH THE REVERSE AND FORWARD DRIVE SAFETY CONTROL LEVERS AT THE SAME TIME.

## **REVERSE LEVER**

*Engages wheels into reverse.*

Pulling the drive safety control lever(**REVERSE**) toward the handlebar reverses the tiller, and the tines will not move.

Releasing the lever stops the wheels.

## **ADJUSTMENTS**



### **WARNING**

**ENGINE SHOULD BE OFF BEFORE ADJUSTING ANY CONTROLS.**

**EXTREME CAUTION SHOULD BE USED WHEN OPERATING ROTOTILLER IN THE REVERSE DIRECTION.**



## **WHEEL LOCK PINS**

*Place wheels in tilling position.*

1. Remove lock pin. Align hole in axle with hole in wheel hub.
  2. Insert lock pin through holes, fold lock pin ring to secure pin to axle.
  3. Firmly lock wheel and axle together before tilling.
  4. Repeat for other wheel.
- Set the depth regulator lever with the detent pin in one of the higher holes. This will allow for shallow cultivation necessary to turn over weeds, and break up and aerate the soil.

## **MAINTENANCE AND STORAGE**

### **MAINTENANCE**

Keeping the tiller in top running condition will prolong the tiller's life, and help it obtain optimum performance whenever you wish to till your garden.

To help you properly care for the rototiller, the following pages include a maintenance schedule, routine inspection procedures, and simple maintenance procedures using basic hand tools. Other service tasks that are more difficult, or require special tools, are best handled by professionals and are normally performed by a qualified mechanic.



- Good maintenance is your responsibility, poor maintenance is an invitation to trouble.

Follow good shop practices.

Keep service area clean and dry.

Be sure electrical outlets and tools are properly grounded.

Use adequate light for the job at hand.

- Make sure the engine is off before you begin any maintenance or repairs. This will eliminate several potential hazards:

### **Carbon monoxide poisoning from engine exhaust.**

Be sure there is adequate ventilation whenever you operate the engine.

Never operate the engine in a closed building.

### **Burns from hot parts.**

Let the engine and exhaust system cool before touching.

### **Injury from moving parts.**

Do not run the engine unless instructed to do so.

- Read the instructions before you begin, and make sure you have the tools and skills required.
- To reduce the possibility of fire or explosion, be careful when working around gasoline.

Use only a nonflammable solvent, not gasoline, to clean parts. Keep cigarettes, sparks and flames away from all fuel-related parts.

- Always use personal protection devices such as eye, hand and hearing protectors when performing any service or maintenance.
- Frequently check tiller tines. They should be free of nicks and cracks and securely fastened in place.
- Periodically tighten all bolts, nuts, screws, and check that all pins are properly installed to make certain unit is safe to operate.
- When completing maintenance or service, make sure all safety guards and devices are

***NOTE: Always have both wheel lock pins in or out. Do not operate tiller with only one wheel locked.***

*To place wheels in free-wheel position.*

1. Remove lock pin. Slide wheel inward toward machine.
2. Insert pin in axle only.

3. Wheel should turn freely on axle.

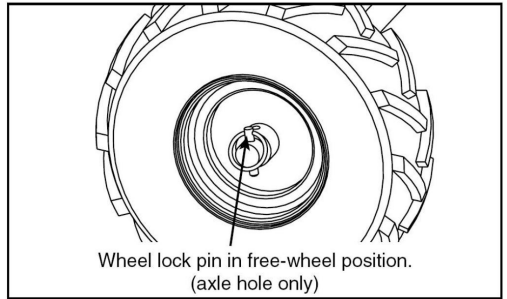

## HANDLEBAR HEIGHT ADJUSTMENT

*Adjust handlebar height.*

The ideal height of the handlebar varies with operator height and the depth of tilling. To adjust handlebar height:

1. Unscrew nuts and remove top and bottom bolts on each side.
2. Align handlebar to desired holes on the lower handlebar mount.
3. Install bolts and nuts. Tight again.

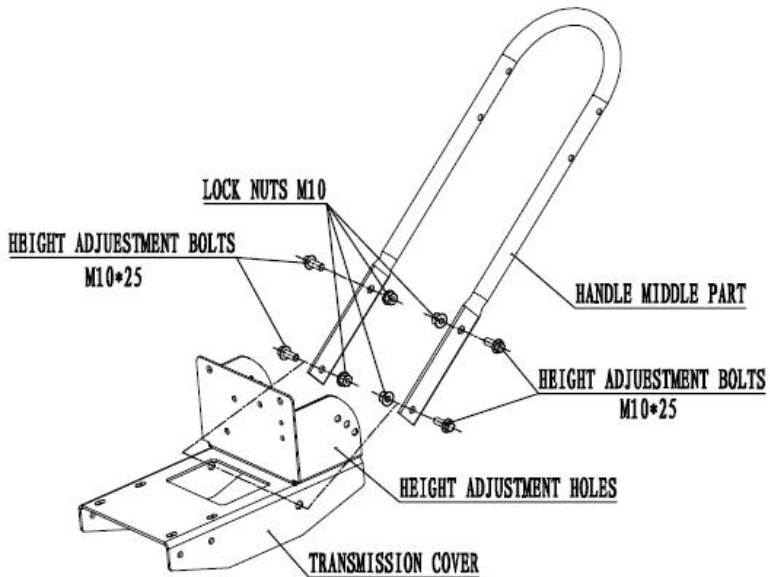

## DEPTH REGULATOR LEVER

Tilling depth is controlled by the height of the depth regulator lever. To adjust tilling depth:

1. Remove detent pin.
2. Raise the depth regulator lever to position tines at chosen tilling depth.
3. Align hole in depth regulator lever with hole in depth regulator bracket and replace detent pin.

### **⚠ WARNING**

DO NOT ADJUST TILLING DEPTH UNLESS DRIVE SAFETY CONTROL LEVERS ARE RELEASED TO NEUTRAL POSITION.

ALWAYS SET THE DEPTH REGULATOR LEVER IN THE TRANSPORT POSITION BEFORE STARTING ENGINE, THAT IS, PLACE THE DETENT PIN IN THE HIGHEST HOLE OF THE DEPTH REGULATOR LEVER.

**Depth Regulator Lever Down** = Shallower tilling.

Place the detent pin in the top hole of the depth regulator lever for shallowest tilling.

**Depth Regulator Lever Up** = Deeper tilling.

Place the detent pin in the bottom hole of the depth regulator lever for deepest tilling.

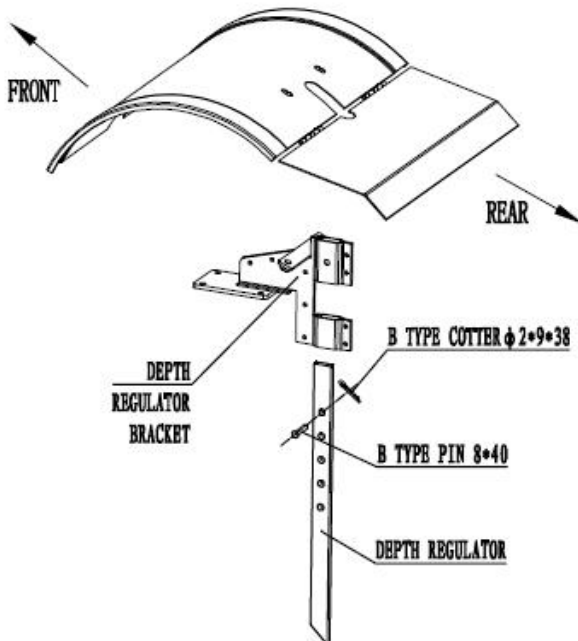

## BELT TENSION ADJUSTMENT

Proper belt tension is critical to good performance. After 1/2 hour of operation, all cables may have to be adjusted due to initial stretch. Thereafter, check tension after every 2 hours of operation.

### **To increase belt tension:**

1. Loosen upper jam nut. Turn nut up cable in 1/8" increments.
2. Tighten lower jam nut.
3. check adjustment.

This procedure can be repeated until conduit adjustment bolts are fully adjusted. If no more adjustment can be made, belt may have to be replaced.

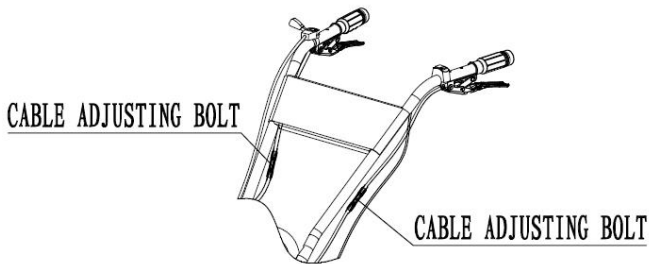

## TILLING TIPS

*The key to successful tilling is to begin with a shallow cut on the first pass, and then work an inch or two deeper on each successive pass.*

- Tilling depth will vary with ground conditions.
- When beginning to till in unbroken ground or in extremely hard soil, set the detent pin in the highest hole of the drag stake (follow instructions under Tilling section). This will allow for shallow tilling.

With the drag stake in this position, make several light passes over the area to be tilled.

Reset for deeper depths with successive passes.

- If tiller jumps or skids uncontrollably, lower the drag stake by placing the detent pin in a higher hole. This will allow for shallower tilling. Hold firmly to the handlebars to control sudden lurches.

### **WARNING**

EXTREME CAUTION MUST BE TAKEN IN SELECTING TILLING DEPTH. IF YOU ATTEMPT TO TILL TOO DEEPLY FOR SOIL CONDITIONS, THAT IS, WITH THE DRAG STAKE IN TOO HIGH A POSITION, LOSS OF CONTROL COULD RESULT.

IF REMOVING MATERIAL FROM THE TINES BY HAND, STOP ENGINE AND REMOVE SPARK PLUG WIRE FIRST.

- If weeds, tall grasses, vines, or other materials clog or jam the tines, reverse the tiller to unwind vegetation.

*Immediately release the drive control levers if the tines jam or you strike a foreign object.*

*With drive control levers in neutral position, push throttle control to stop position to stop the engine. Disengage the spark plug wire. When tines have stopped, remove foreign objects and check for damage.*

## **CULTIVATING TIPS**

If you plan to use your tiller for cultivating:

- Plant rows on 20" - 22" centers for ease of turning.

Installed before using the rototiller.

- Where replacement parts are necessary for periodic maintenance and servicing, use only new, original replacement parts or their equivalents for repair and replacement to restore your equipment to original specifications.
- The manufacturer and/or distributor will not be responsible for injuries or damages caused by use of unapproved parts and/or accessories.
- A first aid kit should be kept readily accessible while performing maintenance on this equipment.

## **MAINTENANCE SCHEDULE**

Your rototiller has been designed and produced by the industry's leading manufacturer of outdoor power equipment to provide you with years of reliable operation.

Keeping your tiller in top running condition will prolong its life, and help you obtain optimum performance.

Please read this normal care schedule, and note the recommended care operating intervals to extend the life of your unit.

Maintenance Operation		Each Use	First Month or 20Hours	Every 3months or 50Hours	Every 6months or 100Hours	Every year or 300 Hours
Drive Belt Tension	Check	√				
	Change	√				
Engine oil	Check level	√	√		√	
	Change					
Air filter	Check	√				
	Clean			√ (1)	√ (1)	
	Replace					√
Tiller Transmission Grease	Check	√				
	Replace			√		
Tire Pressure	Check	√				
Tine Shaft	Clean	√				
Wheel Axle Shaft	Lubricate			√		

1) Service more frequently when used in dusty areas.

## SERVICING THE ROTOTILLER

The following information will help you make the necessary checks and perform the procedures required to follow the normal care recommendations made for your rototiller unit.

If you prefer, your local authorized dealer can make these checks and perform the required procedures for you.

### CHANGE FORWARD/REVERSE BELT

1. Turn off engine. Engine must be cool.
2. Remove spark plug wire and secure from spark plug.
3. Remove belt guard.
  - remove the forward belt from the forward engine pulley:
    - gently pull the engine recoil rope to rotate the pulley.

**⚠ WARNING**

To prevent accidental starting:

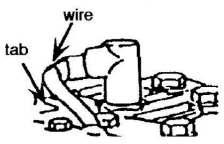

Engine must be turned off and cool, and spark plug wire must be removed and secured from spark plug before checking and adjusting engine or equipment.

- with the pulley turning, force the forward belt out of the V-groove.
- slide the belt free of the engine pulley.
- pull the forward belt down and out of the way.

**CAUTION**  
DO NOT OPERATE TILLER BEFORE READING THE ENGINE MANUAL PROVIDED IN THE PARTS PACKET.

- remove the reverse belt from the reverse engine pulley:
  - gently pull the engine recoil rope to rotate the pulley.

**WARNING**  
TEMPERATURE OF MUFFLER AND NEAR BY AREAS MAY EXCEED 150° F. AVOID THESE AREAS.

- with the pulley turning, force the reverse belt out of the V-groove.
- slide the belt free of engine pulleys and reverse belt guides.

**IMPORTANT**  
ENGINE CAN OVERHEAT AND BECOME DAMAGED IF DEBRIS BLOCKS THE COOLING SYSTEM OR ROTATING SCREEN.  
NEVER RUN ENGINE WITHOUT COMPLETE AIR CLEANER INSTALLED ON ENGINE.

- pull belt down and away from transmission pulley.
- install new reverse belt:

- thread belt up from bottom.
- place belt around transmission pulley in groove.
- place belt under reverse belt guides.
- gently pull engine recoil rope while forcing the belt over the edge of the engine pulley into the V-groove.

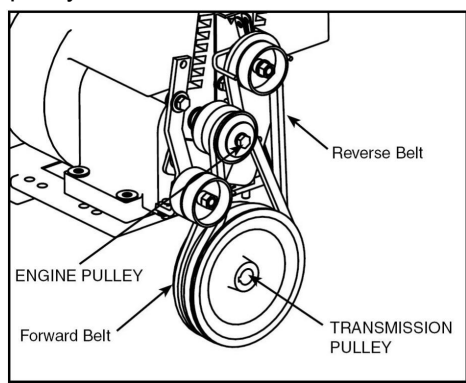

- install new forward belt:
  - place forward belt in transmission pulley groove.
  - gently pull the engine recoil rope to rotate the pulley while forcing the forward belt into the V-groove.

4. Replace belt guard.
5. Attach spark plug wire.

## ENGINE MAINTENANCE

Refer to the engine manual included in your parts packet for information on engine maintenance. Your engine manual provides detailed information and a maintenance schedule for performing the following tasks:

1. Check oil level before each use or after every 8 hours of operation.
2. Change oil after first 5-8 hours of operation. change oil while engine is warm. Refill with new oil of recommended grade.

4. Check spark plug yearly or every 100 hours of operation.
5. Service air cleaner.
6. Keep engine and parts clean.
7. Check engine and equipment often for loose nuts and bolts, keep these items tightened.

## CHECK OR FILL ENGINE CRANKCASE

1. Add oil according to engine manual. **Do not overfill.** Use a clean, high quality detergent oil. **Do not mix oil with gasoline.**

Oil level must be full. check the oil level by removing oil fill plug. Oil level should be up to the bottom of the fill plug opening.

2. Always check oil level before starting engine. Refer to engine manual for capacity and type of oil to use.

### IMPORTANT

ENGINE IS SHIPPED FROM FACTORY WITHOUT OIL. YOU MUST ADD ENGINE OIL BEFORE STARTING ENGINE.

## CHECK TILLER TRANSMISSION GREASE

Check the grease level annually. To check the grease level:

1. Move tiller to level ground.
2. Remove grease level dipstick located between the handlebar mounts on the engine mount. If the grease level couldn't touch the dipstick, pls fill the grease.
3. Replace grease level dipstick in the filler hole.
4. Note that the front wheel transmission and rear tine transmission are one common 17reservoir. When you add to the front

transmission, you must wait a short period of time for the grease to flow rearward and equalize in both front and rear. The dipstick will read correctly on level ground for both gear units.

### IMPORTANT

TILLER TRANSMISSION IS SHIPPED FROM FACTORY WITH THE PROPER AMOUNT OF LIQUID GREASE.

WHEN REPLACING GREASE, THE TILLER TRANSMISSION HOLDS 18-22 OUNCES. DO NOT OVERFILL.

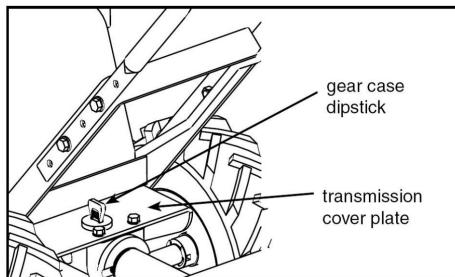

## CHECK TIRE PRESSURE

Recommended tire pressure is 20 PSI. If tires do not have equal pressure, tiller will pull to one side.



## LUBRICATION

Proper lubrication of moving mechanical parts is critical for proper care and maintenance.

Oil the moving parts shown at 10 hour intervals using a 30 weight oil.

### CLEAN TINE AXLE SHAFT

1. Turn off engine. Engine must be cool.
2. Remove spark plug wire and secure from spark plug.
3. Tip the tiller forward. Block the tiller in position so that it rests on the engine mount and the tines are exposed.
4. Remove all vegetation, string, wire, and other material that may have accumulated on the axle between the inside set of tines and the seal on the transmission housing.
5. Tip the tiller back to a level position.
6. Replace spark plug wire.

## STORAGE

### PREPARE FOR STORAGE

Follow the steps below to prepare your tiller for storage. Read your engine manual for detailed instructions on preparing the engine for storage.

1. Protect wheels and axles from rust:
  - Remove lockpin and slide wheel off hub.
  - Coat the axles lightly with axle grease.
  - Slide wheel back on hub and insert lock pin.
2. Drain fuel system completely following engine manufacturer's instructions or add fuel stabilizer to prevent fuel from gumming up during extended storage period.
3. While engine is still warm, drain the oil from the engine. Refill with fresh oil of the recommended grade.
4. clean external surfaces, engine and cooling fan.
5. Remove spark plug, pour one ounce of SAE 30 oil into spark plug hole.
6. Plug hole and pull starter cord slowly to distribute oil evenly in cylinder head area.
7. Reinstall spark plug.

#### **WARNING**

DO NOT STORE TILLER IN AN UNVENTILATED AREA WHERE FUEL FUMES MAY REACH FLAME, SPARKS, PILOT LIGHTS OR AN IGNITED OBJECT. DRAIN FUEL OUTDOORS AWAY FROM ANY IGNITION SOURCES. USE ONLY APPROVED FUEL CONTAINERS.

8. Transport unit to a suitable storage location. If you have chosen to use a fuel stabilizer and have not drained the fuel system, follow all safety instructions storage precautions in this manual to prevent the possibility of fire from the ignition of gasoline fumes. Remember, gasoline fumes can travel to distant sources of ignition and ignite, causing risk of explosion and fire.

9. If there is any possibility of unauthorized use or tampering, remove the spark plug and store it in a safe place before storing the rototiller unit. Be sure to plug the spark plug hole to prevent foreign material from entering.

## TROUBLESHOOTING AND REPAIR

### TROUBLESHOOTING GUIDE

While normal care and routine maintenance will extend the life of your rototiller, prolonged or constant use may eventually require that service be performed to allow it to continue operating properly. The troubleshooting guide below lists the most common problems, causes and remedies.

PROBLEM	REMEDY/ACTION
Engine can not start	<ul style="list-style-type: none"> <li>• Add gas to gas tank.</li> <li>• Connect spark plug wire to spark plug</li> <li>• Throttle must be positioned at choke for a cold start</li> </ul>
Engine runs rough, foods during operation	<ul style="list-style-type: none"> <li>• Clean or replace air cleaner</li> </ul>
Engine is hard to start	<ul style="list-style-type: none"> <li>• Drain old fuel and replace with fresh. Use gas stabilizer at end of season</li> <li>• Make sure spark plug wire is securely attached to spark plug</li> <li>• Drive safety control levers must be released to neutral position to start the engine</li> </ul>
Engine misses or lacks power	<ul style="list-style-type: none"> <li>• Raise the tines for shallow tilling by lowering the depth regulator lever</li> <li>• Remove and clean fuel tank</li> <li>• Clean or replace air cleaner</li> </ul>

	<ul style="list-style-type: none"> <li>• Improper carburetor adjustment, take to authorized engine service center</li> <li>• Replace spark plug and adjust gap</li> <li>• Drain and refill gas tank and carburetor</li> </ul>
Engine can not stop when throttle control is positioned at stop	<ul style="list-style-type: none"> <li>• See engine manual to check and adjust throttle linkage</li> </ul>
Tiller moves forward during starting	<ul style="list-style-type: none"> <li>• Drive safety control levers must be released to neutral position to start the engine</li> </ul>
Tiller is difficult to control when tilling (machine jumps or lurches forward)	<ul style="list-style-type: none"> <li>• Lock wheels in tilling position</li> <li>• Raise the tines for shallower tilling by lowering the depth regulator lever</li> </ul>
Tines turn but wheels do not turn	<ul style="list-style-type: none"> <li>• Lock wheels in tilling position</li> <li>• Internal transmission failure, see your dealer</li> </ul>
Tines turn, wheels turn, tiller does not move	<ul style="list-style-type: none"> <li>• Lower the tines for deeper tilling by raising the depth regulator lever</li> </ul>
Belts squeal in neutral and/or reverse	<ul style="list-style-type: none"> <li>• Adjust forward belt guide: <ul style="list-style-type: none"> <li>- turn engine off and allow muffler to cool</li> <li>- disconnect spark plug wire and secure from spark plug</li> <li>- remove belt guard</li> <li>- pull down on drive safety control levers</li> <li>- manually bend forward belt guide so there is 1/16 inch or less clearance between belt guide and belt</li> <li>- replace belt guard and spark plug wire</li> </ul> </li> </ul>
Belts squeal in forward operation	<ul style="list-style-type: none"> <li>• Adjust tabs on the reverse belt guide <ul style="list-style-type: none"> <li>- turn engine off and allow muffler to cool</li> <li>- disconnect spark plug wire and secure from spark plug</li> <li>- release drive safety control levers to neutral position</li> </ul> </li> </ul>

	<ul style="list-style-type: none"> <li>- remove belt guard</li> <li>- adjust tabs of reverse belt guide: while drive safety control levers are released, bend metal tabs on reverse belt guide to 1/64 inch or less clearance from reverse belt</li> <li>- replace belt guard and spark plug wire</li> </ul>
Excessive heat build up in transmission/tine area during tilling	<ul style="list-style-type: none"> <li>• Remove vegetation by following instructions in clean Tine Axle Shaft of Normal care section.</li> </ul> <p><b>FOLLOW ALL SAFETY INSTRUCTIONS</b></p> <ul style="list-style-type: none"> <li>• Check transmission</li> </ul>

## TECHNICAL DIAGRAM

Tilling Scope	500mm
Tilling Depth	175~350mm
Gear Shifting	0, 1, -1
Engine Type	OHV 4-stroke
Starting System	Recoil
Displacement	212cc
Max Output	7.0HP/3600rpm
Engine Speed	3600rpm
Fuel Volume	3.6 L
Oil Volume	0.6 L
Fuel Type	Unleaded Gasoline

# DECLARATION OF CONFORMITY



## EC DECLARATION OF CONFORMITY



### For the following machinery

- Product name: Motor Hoe
- Commercial name: N/A
- Function: Motor Hoe
- Type: Gasoline
- Model No.: SRHX-50

### is herewith confirmed to fulfill all the relevant provisions of

- Machinery Directive (2006/42/EC)
- Electromagnetic Compatibility Directive (2014/30/EU)

### and the following harmonized standard have been complied with

- EN 709:1997+A4; EN 709:1997+A4/AC
- EN ISO 14982:2009

### Responsible for marking this declaration is the

Manufacture's Name : Chongqing Shineray Agricultural Machinery Co., Ltd.  
Manufacturer's Address : 8 Shineray Road, Hangu Town, Jiulongpo District,  
Chongqing 401329, China

### Person responsible for making this declaration

Name, Surname : Yao, Su ling  
Position/Title : Certification Engineer  
Place : Chongqing  
Date : 2022.10.09

(Company stamp and legal signature)



**Manufacturer:**Shanghaimuxinmuyeyouxiangongsi

**Address:** Shuangchenglu 803nong11hao1602A-1609shi, baoshanqu, shanghai  
200000 CN.

**Imported to AUS:** SIHAO PTY LTD. 1 ROKEVA STREETEASTWOOD NSW 2122  
Australia

**Imported to USA:** Sanven Technology Ltd. Suite 250, 9166 Anaheim Place,  
Rancho Cucamonga, CA 91730

<b>EC</b>	<b>REP</b>
-----------	------------

E-CrossStu GmbH  
Mainzer Landstr.69, 60329 Frankfurt am Main.

<b>UK</b>	<b>REP</b>
-----------	------------

YH CONSULTING LIMITED.  
C/O YH Consulting Limited Office 147, Centurion House,  
London Road, Staines-upon-Thames, Surrey, TW18 4AX



**VEVOR<sup>®</sup>**

**TOUGH TOOLS, HALF PRICE**

**Technical Support and E-Warranty Certificate**

**[www.vevor.com/support](http://www.vevor.com/support)**