

VEVOR

Affordable. Reliable. Home Improvement.

Voltage Sensitive Relay

MODEL: VSR003, VSR003-1

VEVOR



Affordable. Reliable. Home Improvement.

MODEL: VSR003, VSR003-1



(The picture is for reference only, please refer to the actual object)

This is the original instruction, please read all manual instructions carefully before operating. VEVOR reserves a clear interpretation of our user manual. The appearance of the product shall be subject to the product you received. Please forgive us that we won't inform you again if there are any technology or software updates on our product.

	<p>Warning-To reduce the risk of injury, user must read instructions manual carefully.</p>
	<p>This product is subject to the provision of European Directive 2012/19/EC. The symbol showing a wheeled bin crossed through indicates that the product requires separate refuse collection in the European Union. This applies to the product and all accessories marked with this symbol. Products marked as such may not be discarded with normal domestic waste, but must be taken to a collection point for recycling electrical and electronic devices</p>

WIRING INSTRUCTIONS

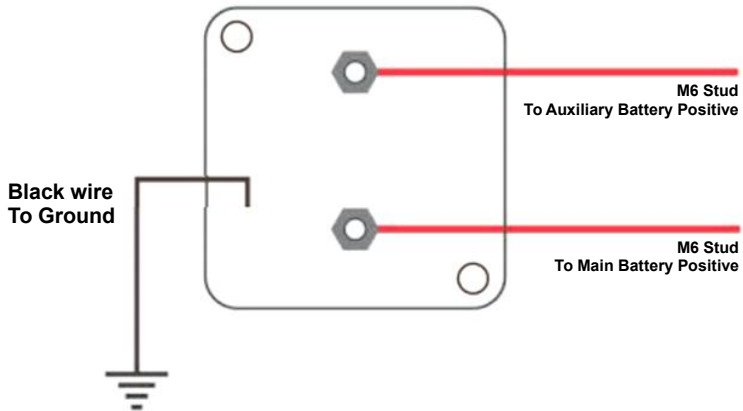

1. Function Introduction

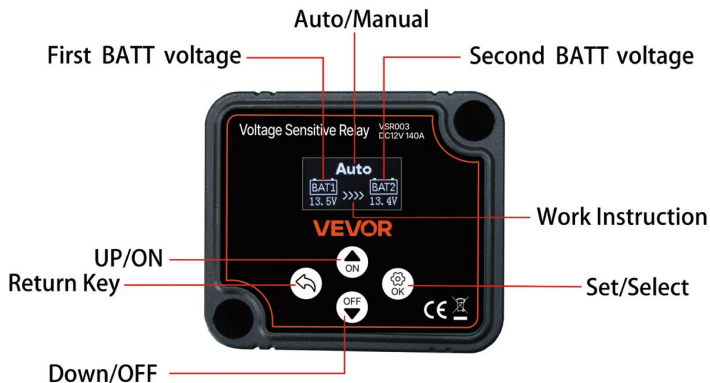

2. Default Function

1. After connecting the battery, the display screen will display the voltage of AUTO, BATT1 and BATT2 , The voltage display range is 4.5V~20V.

2. When the input voltage of battery 1 exceeds 13.3V, the working circuit of the isolator will be automatically connected on, and the display screen will show

3. When the input voltage drops to 12.7V, the circuit will be disconnected automatically. Do not display

4. Please connect the main battery with charging function to BATT1, Otherwise, the isolator will not work normally

5. The display will turn off automatically after being kept on for 15 seconds. and you need to press the setting key to turn it on again

3. High voltage、 low voltage protection

1. When the input voltage is lower than 11V, the isolator will automatically disconnect and stop working. Protect the main battery from being damaged by overuse.

2. When the input voltage is higher than 17V, the circuit will automatically disconnect and stop working Protect the battery from damage.

4. Function Setting



Long press 3 seconds, go to the home page, the isolator is disconnected by default.

1. Automatic state to Manual state

Long press 3 Seconds



Click "OK"



Click select



Click back



Click "OK"



2. Operating Voltage Setting

Long press 3 Seconds



Click select



Click "OK"



Click "OK"



3. Delay setting

Long press 3 Seconds



Click select



Click "OK"



Click "OK"



TECHNICAL SPECIFICATIONS

VOLTAGE	12V
CHARGING CURRENT	90-120 AMP CONTINUOUS, 160 AMP PEAK
CURRENT DRAW	CHARGING 330mA, STANDBY 1mA
CUT-IN VOLTAGE	13.3V (Adjustable)
CUT-OUT VOLTAGE	12.7V (Adjustable)
CUT-OUT DELAY	3-5 SECONDS(Adjustable)
IP RATING	IP67

Manufacturer: Shanghai muxinmuyeyouxiangongsi

Address: Shuangchenglu 803nong11hao1602A-1609shi, baoshanqu, shanghai 200000 CN.

Imported to AUS: SIHAO PTY LTD. 1 ROKEVA STREET EASTWOOD NSW 2122 Australia

Imported to USA: Sanven Technology Ltd. Suite 250, 9166 Anaheim Place, Rancho Cucamonga, CA 91730

UK	REP
-----------	------------

YH CONSULTING LIMITED. C/O YH Consulting Limited Office 147, Centurion House, London Road, Staines-upon-Thames, Surrey, TW18 4AX

EC	REP
-----------	------------

E-CrossStu GmbH
Mainzer Landstr.69,
60329 Frankfurt am Main.

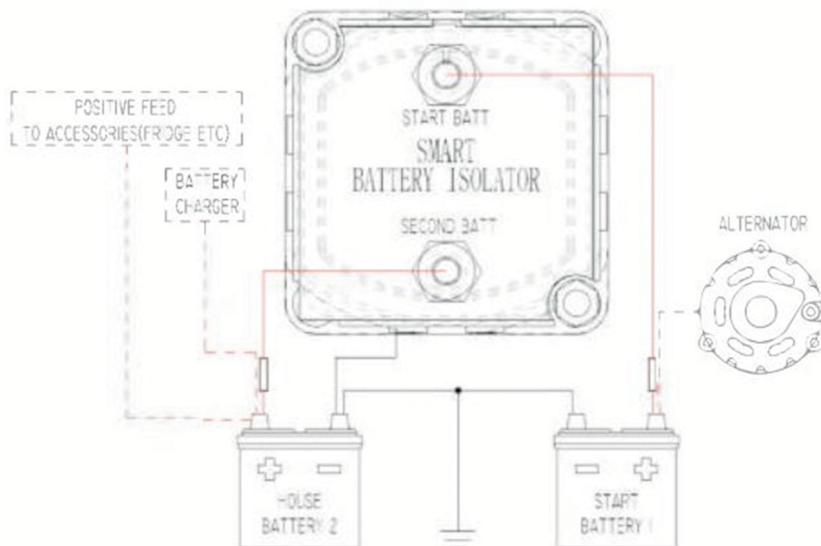

VSR003-1 List of Kit Accessories

1. Voltage Sensitive Relay *1
2. 6AWG x 600cm Red Battery Cable *1
3. 5AWG x 60cm Black Battery Cable *1
4. 25-8 Lug Cable End *1
5. 16-8 Lug Cable Ends *2
6. Blue Ring Terminal *1
7. Red Heat Shrink Tubing *2
8. Black Heat Shrink Tubing *1
9. Cable Ties *6
10. M4 x 40mm Screws *2
11. M4 x 20mm Screws *2
12. Battery Terminals *3



VEVOR

Affordable. Reliable. Home Improvement.

Relais sensible à la tension

MODÈLE : VSR003, VSR003-1

VEVOR

Affordable. Reliable. Home Improvement.

MODÈLE : VSR003, VSR003-1



(L'image est à titre indicatif uniquement, veuillez vous référer à l'objet réel)

Ceci est le mode d'emploi d'origine. Veuillez lire attentivement l'intégralité du manuel avant utilisation. VEVOR se réserve le droit d'interpréter clairement ce manuel d'utilisation. L'apparence du produit dépend du produit que vous avez reçu. Veuillez nous excuser de ne pas vous informer ultérieurement des mises à jour technologiques ou logicielles de notre produit.



Avertissement - Pour réduire le risque de blessure, l'utilisateur doit lire attentivement le manuel d'instructions.



Ce produit est soumis aux dispositions de la directive européenne 2012/19/CE. Le symbole représentant une poubelle barrée indique que le produit doit faire l'objet d'une collecte sélective dans l'Union européenne. Ceci s'applique au produit et à tous les accessoires marqués de ce symbole. Les produits ainsi marqués ne doivent pas être jetés avec les ordures ménagères, mais doivent être déposés dans un point de collecte pour le recyclage des appareils électriques et électroniques.

INSTRUCTIONS DE CÂBLAGE

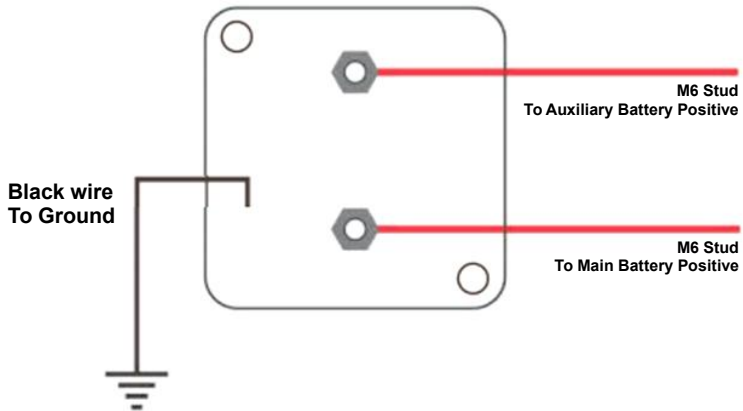

1. Introduction à la fonction

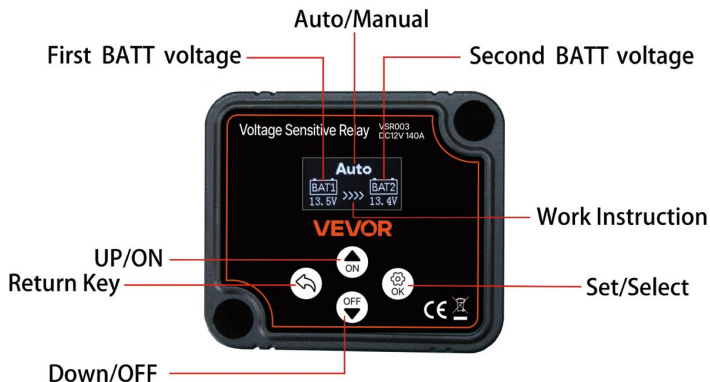

2. Fonction par défaut

1. Après avoir connecté la batterie, l'écran d'affichage affichera la tension de AUTO, BATT1 et BATT2, la plage d'affichage de la tension est de 4,5 V à 20 V.

2. Lorsque la tension d'entrée de la batterie 1 dépasse 13,3 V, le circuit de travail de l'isolateur sera automatiquement connecté et l'écran d'affichage affichera

3. Lorsque la tension d'entrée chute à 12,7 V, le circuit se déconnecte automatiquement. Ne afficher

4. Veuillez connecter la batterie principale avec fonction de charge à BATT1, sinon l'isolateur ne fonctionnera pas normalement

5. L'écran s'éteint automatiquement après avoir été allumé pendant 15 secondes. et vous devez appuyer sur la touche de réglage pour le rallumer

3. Protection haute tension et basse tension

1. Lorsque la tension d'entrée est inférieure à 11 V, l'isolateur se déconnecte automatiquement et cesse de fonctionner. Protégez la batterie principale contre les dommages causés par une utilisation excessive .

2. Lorsque la tension d'entrée est supérieure à 17 V, le circuit se déconnecte automatiquement et cesse de fonctionner. Protégez la batterie contre les dommages.

4. Réglage des fonctions

Appuyez longuement



3 secondes, accédez à la page d'accueil, l'isolateur est déconnecté par défaut.

1. État automatique vers état manuel

Long press 3 Seconds



Click "OK"



Click select



Click back



Click "OK"



2. Réglage de la tension de fonctionnement

Long press 3 Seconds



Click select



Click "OK"



Click "OK"



3. Réglage du délai

Long press 3 Seconds



Click select



Click "OK"



Click "OK"



CARACTÉRISTIQUES TECHNIQUES

TENSION	12 V
COURANT DE CHARGE	90-120 ampères CONTINU, 160 AMP CULMINER
TIRAGE ACTUEL	CHARGE 330 mA, VEILLE 1 mA
TENSION DE DÉCLENCHEMENT	13,3 V (réglable)
TENSION DE COUPURE	12,7 V (réglable)
RETARD DE COUPURE	3 à 5 secondes (réglable)
INDICE DE PROTECTION IP	IP67

Fabricant : Shanghai muxinmuyeyouxiangongsi

Adresse : Shuangchenglu 803nong11hao1602A-1609shi, baoshanqu, Shanghai 200 000 CN.

Importé en Australie : SIHAO PTY LTD. 1 ROKEVA STREET, ASTWOOD NSW 2122 Australie

Importé aux États-Unis : Sanven Technology Ltd. Suite 250, 9166 Anaheim

Lieu, Rancho Cucamonga, CA 91730

UK	REP
-----------	------------

YH CONSULTING LIMITED. C/O YH Consulting Limited Office 147, Centurion House, London Road, Staines-upon-Thames, Surrey, TW18 4AX

EC	REP
-----------	------------

E-CrossStu GmbH
Mainzer Landstr.69,
60329 Frankfurt am Main.

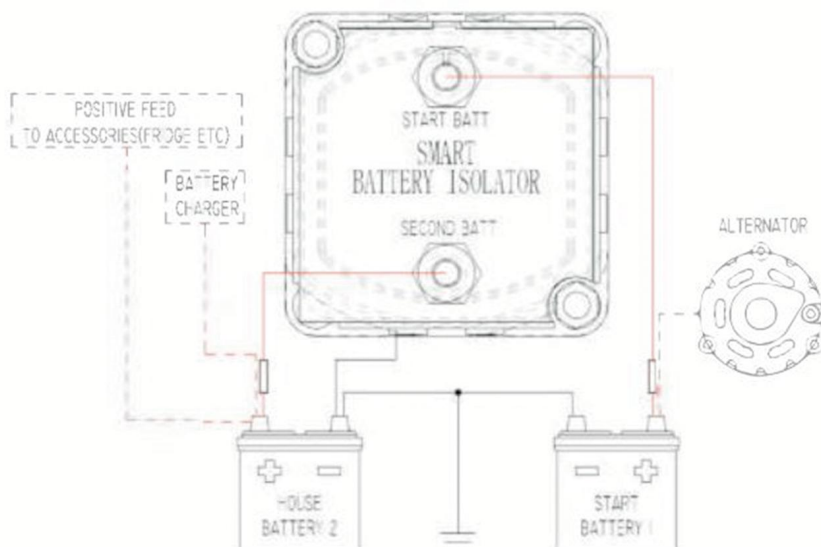

VSR003 -1 Liste des accessoires du kit

1. Relais sensible à la tension *1
2. Câble de batterie rouge 6 AWG x 600 cm *1
noir 3,5 AWG x 60 cm *1
- 4 . 2 5- 8 Extrémité de câble à cosse * 1
5. 16 - 8 embouts de câble à cosse * 2
6. Borne à anneau bleu *1
7. Gaine thermorétractable rouge *2
- 8 . Gaine thermorétractable noire * 1
- 9 . Serre-câbles *6
- 10 . Vis M4 x 40 mm * 2
- 11 . Vis M4 x 20 mm * 2
- 1 2 . Bornes de batterie *3



VEVOR

Affordable. Reliable. Home Improvement.

Spannungsempfindliches Relais

MODELL: VSR003, VSR003-1

VEVOR

Affordable. Reliable. Home Improvement.

MODELL: VSR003, VSR003-1



(Das Bild dient nur als Referenz, bitte beziehen Sie sich auf das tatsächliche Objekt)

Dies ist die Originalanleitung. Bitte lesen Sie alle Anweisungen sorgfältig durch, bevor Sie das Gerät in Betrieb nehmen. VEVOR behält sich eine klare Auslegung unserer Bedienungsanleitung vor. Das Aussehen des Produkts hängt vom gelieferten Produkt ab. Bitte haben Sie Verständnis dafür, dass wir Sie nicht erneut über Technologie- oder Software-Updates informieren.



Warnung: Um das Verletzungsrisiko zu verringern, muss der Benutzer die Bedienungsanleitung sorgfältig lesen.



Dieses Produkt unterliegt den Bestimmungen der europäischen Richtlinie 2012/19/EU. Das Symbol einer durchgestrichenen Mülltonne weist darauf hin, dass dieses Produkt in der Europäischen Union einer getrennten Müllentsorgung unterliegt. Dies gilt für das Produkt und alle mit diesem Symbol gekennzeichneten Zubehörteile. Entsprechend gekennzeichnete Produkte dürfen nicht im Hausmüll entsorgt werden, sondern müssen an einer Sammelstelle für das Recycling von Elektro- und Elektronikgeräten abgegeben werden.

VERKABELUNGSANLEITUNG

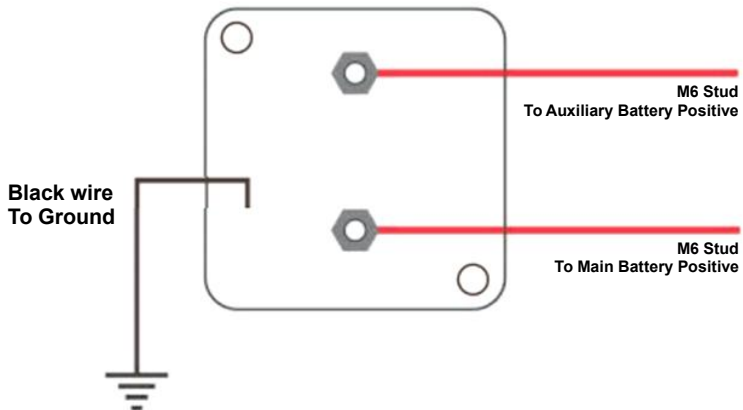

1. Funktionseinführung

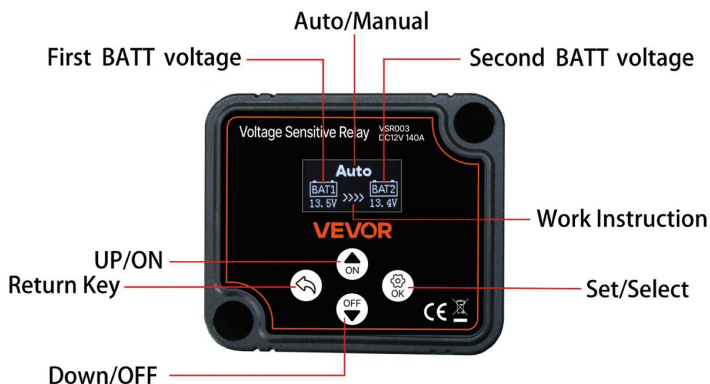

2. Standardfunktion

1. Nach dem Anschließen der Batterie wird auf dem Display die Spannung angezeigt AUTO, BATT1 und BATT2, der Spannungsanzeigebereich liegt zwischen 4,5 V und 20 V.
2. Wenn die Eingangsspannung der Batterie 13,3 V überschreitet, wird der Arbeitskreis des Isolators automatisch eingeschaltet und auf dem Display wird angezeigt
3. Wenn die Eingangsspannung auf 12,7 V fällt, wird der Stromkreis automatisch getrennt. Nicht Anzeige

4. Bitte schließen Sie die Hauptbatterie mit Ladefunktion an BATT1 an, sonst funktioniert der Isolator nicht normal

5. Das Display schaltet sich automatisch aus, nachdem es 15 Sekunden lang eingeschaltet war. Sie müssen die Einstellungstaste drücken, um es wieder einzuschalten

3. Hochspannungs- und Niederspannungsschutz

1. Wenn die Eingangsspannung unter 11 V liegt, wird der Isolator automatisch getrennt und funktioniert nicht mehr. Schützen Sie die Hauptbatterie vor Schäden durch Überbeanspruchung .
2. Wenn die Eingangsspannung höher als 17 V ist, wird der Stromkreis automatisch getrennt und hört auf zu arbeiten. Schützen Sie die Batterie vor Schäden.

4. Funktionseinstellung



lang drücken , zur Startseite gehen, der Isolator ist standardmäßig getrennt.

1. Automatischer Zustand in manuellen Zustand

Long press 3 Seconds



Click "OK"



Click select



Click back



Click "OK"



2. Betriebsspannungseinstellung

Long press 3 Seconds



Click select



Click "OK"



Click "OK"



3. Verzögerungseinstellung

Long press 3 Seconds



Click select



Click "OK"



Click "OK"



TECHNISCHE SPEZIFIKATIONEN

STROMSPANNUNG	12 V
LADESTROM	90–120 Ampere KONTINUIERLICH, 160 AMPERE GIPFEL
AKTUELLE AUSZAHLUNG	LADEN 330 mA, STANDBY 1 mA
EINSCHALTSPANNUNG	13,3 V (einstellbar)
ABSCHALTSPANNUNG	12,7 V (einstellbar)
AUSSCHALTVERZÖGERUNG	3–5 SEKUNDEN (einstellbar)
IP-SCHUTZ	IP67

Hersteller: Shanghaimuxinmuyeyouxiangongsi

Adresse: Shuangchenglu 803nong11hao1602A-1609shi, baoshanqu, Shanghai 200000 CN.

Importiert nach AUS: SIHAO PTY LTD. 1 ROKEVA STREETEASTWOOD NSW 2122 Australien

Importiert in die USA: Sanven Technology Ltd. Suite 250, 9166 Anaheim Place, Rancho Cucamonga, CA 91730

UK	REP
-----------	------------

YH CONSULTING LIMITED. C/O YH Consulting Limited Office 147, Centurion House, London Road, Staines-upon-Thames, Surrey, TW18 4AX

EC	REP
-----------	------------

E-CrossStu GmbH
Mainzer Landstr.69,
60329 Frankfurt am Main.

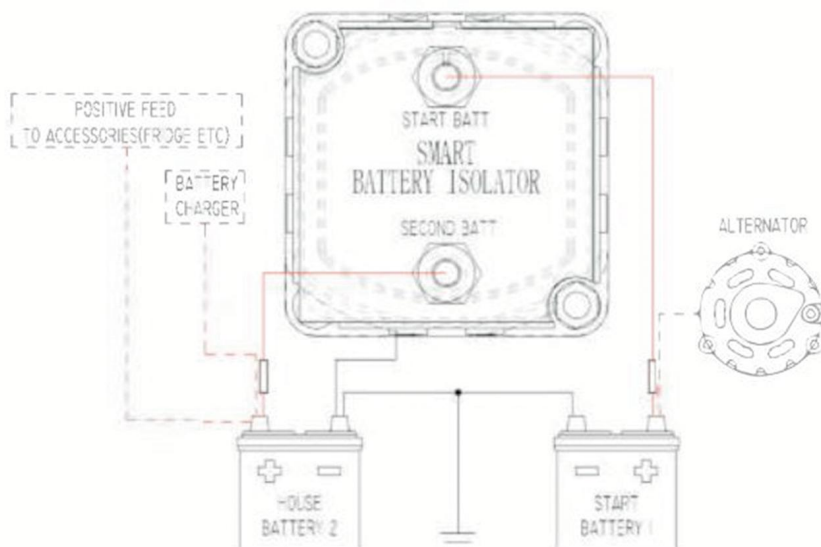

VSR003 -1 Liste des Kit-Zubehörs

1. Spannungsempfindliches Relais *1
2. 6 AWG x 600 cm rotes Batteriekabel * 1
3. 5 AWG x 60 cm schwarzes Batteriekabel * 1
4. 2 5-8 Kabelschuh- Endstück * 1
5. 16 - 8 Kabelschuhe * 2
6. Blauer Ringanschluss *1
7. Roter Schrumpfschlauch *2
8. Schwarzer Schrumpfschlauch * 1
9. Kabelbinder *6
10. M4 x 40 mm Schrauben *2
11. M4 x 20 mm Schrauben *2
12. Batterieklemmen *3



VEVOR

Affordable. Reliable. Home Improvement.

Relè sensibile alla tensione

MODELLO: VSR003, VSR003-1

VEVOR

Affordable. Reliable. Home Improvement.

MODELLO: VSR003, VSR003-1



(L'immagine è solo di riferimento, fare riferimento all'oggetto reale)

Queste sono le istruzioni originali, si prega di leggere attentamente tutte le istruzioni del manuale prima dell'uso. VEVOR si riserva la piena interpretazione del proprio manuale utente. L'aspetto del prodotto dipenderà dal prodotto ricevuto. Vi preghiamo di non informarvi più in caso di aggiornamenti tecnologici o software sul nostro prodotto.



Avvertenza: per ridurre il rischio di lesioni, l'utente deve leggere attentamente il manuale di istruzioni.



Questo prodotto è soggetto alle disposizioni della Direttiva Europea 2012/19/CE. Il simbolo raffigurante un bidone della spazzatura barrato indica che il prodotto richiede la raccolta differenziata nell'Unione Europea. Questo vale per il prodotto e tutti gli accessori contrassegnati da questo simbolo. I prodotti contrassegnati come tali non possono essere smaltiti con i normali rifiuti domestici, ma devono essere conferiti presso un punto di raccolta per il riciclaggio di apparecchiature elettriche ed elettroniche.

ISTRUZIONI DI CABLAGGIO

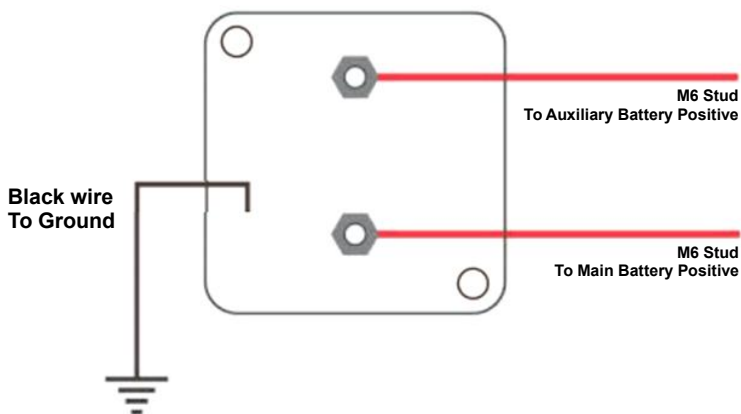

1. Introduzione alla funzione

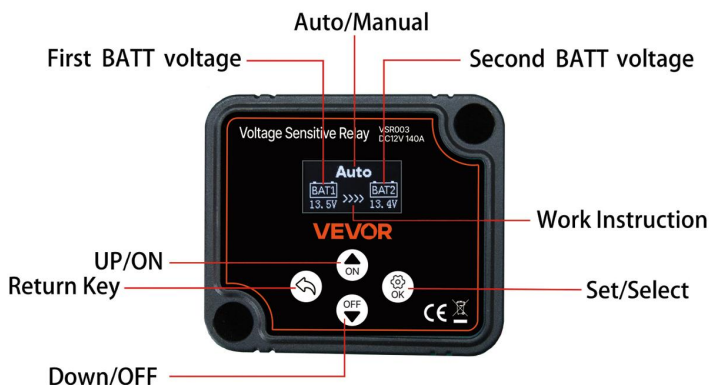

2. Funzione predefinita

1. Dopo aver collegato la batteria, lo schermo del display visualizzerà la tensione di AUTO, BATT1 e BATT2, l'intervallo di visualizzazione della tensione è 4,5 V ~ 20 V.

2. Quando la tensione di ingresso della batteria 1 supera 13,3 V, il circuito di lavoro dell'isolatore verrà automaticamente collegato e lo schermo del display mostrerà

3. Quando la tensione di ingresso scende a 12,7 V, il circuito verrà disconnesso automaticamente. Non display

4. Collegare la batteria principale con funzione di ricarica a BATT1, altrimenti l'isolatore non funzionerà normalmente

5. Il display si spegnerà automaticamente dopo essere stato tenuto acceso per 15 secondi e sarà necessario premere il tasto di impostazione per riaccenderlo.

3. Protezione da alta tensione e bassa tensione

1. Quando la tensione di ingresso è inferiore a 11 V, l'isolatore si disconnette automaticamente e smette di funzionare. Protegge la batteria principale da danni dovuti a un uso eccessivo .

2. Quando la tensione di ingresso è superiore a 17 V, il circuito si disconetterà automaticamente e smetterà di funzionare. Proteggere la batteria da eventuali danni.

4. Impostazione della funzione



Premere a lungo per 3 secondi, si va alla home page, l'isolatore è disconnesso per impostazione predefinita.

1. Da stato automatico a stato manuale

Long press 3 Seconds



Click "OK"



Click select



Click back



Click "OK"



2. Impostazione della tensione di esercizio

Long press 3 Seconds



Click select



Click "OK"



Click "OK"



3. Impostazione del ritardo

Long press 3 Seconds



Click select



Click "OK"



Click "OK"



SPECIFICHE TECNICHE

VOLTAGGIO	12V
CORRENTE DI CARICA	90-120 AMP CONTINUO, 160 AMP PICCO
PRESA DI CORRENTE	RICARICA 330mA, STANDBY 1mA
TENSIONE DI INSERIMENTO	13,3 V (regolabile)
TENSIONE DI INTERRUZIONE	12. 7 V (regolabile)
RITARDO DI INTERRUZIONE	3-5 SECONDI (regolabile)
CLASSIFICAZIONE IP	IP67

Produttore: Shanghai muxin muyeyouxiangongsi

Indirizzo: Shuangchenglu 803nong11hao1602A-1609shi, baoshanqu, Shanghai 200000 CN.

Importato in AUS: SIHAO PTY LTD. 1 ROKEVA STREET EASTWOOD
Nuovo Galles del Sud 2122 Australia

Importato negli USA: Sanven Technology Ltd. Suite 250, 9166 Anaheim
Luogo, Rancho Cucamonga, CA 91730

UK	REP
-----------	------------

YH CONSULTING LIMITED. C/O YH Consulting
Limited Office 147, Centurion House, London
Road, Staines-upon-Thames, Surrey, TW18 4AX

EC	REP
-----------	------------

E-CrossStu GmbH
Mainzer Landstr.69,
60329 Frankfurt am Main.

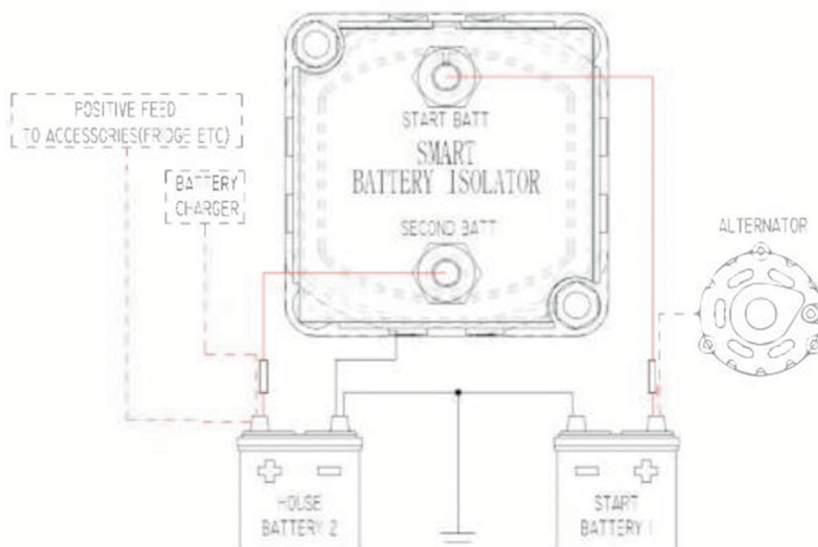

VSR003 -1 Elenco degli accessori del kit

1. Relè sensibile alla tensione *1
2. Cavo batteria rosso 6 AWG x 600 cm *1
Cavo batteria nero da 3,5 AWG x 60 cm *1
- 4 . 2 5- 8 estremità del cavo a capocorda * 1
5. 16 - 8 estremità del cavo a capocorda * 2
6. Terminale ad anello blu *1
7. Guaina termorestringente rossa *2
- 8 . Guaina termorestringente nera * 1
- 9 . Fascette fermacavi *6
- 10 . Viti M4 x 40 mm *2
- 11 . Viti M4 x 20 mm *2
- 1 2 . Terminali della batteria *3



VEVOR

Affordable. Reliable. Home Improvement.

Relé sensible al voltaje

MODELO: VSR003, VSR003-1

VEVOR

Affordable. Reliable. Home Improvement.

MODELO: VSR003, VSR003-1



(La imagen es solo de referencia, consulte el objeto real)

Estas son las instrucciones originales; lea atentamente todas las instrucciones del manual antes de utilizarlo. VEVOR se reserva el derecho de interpretar este manual de usuario. La apariencia del producto dependerá del producto que haya recibido. Le rogamos que nos disculpe si no le informamos de nuevo si hay actualizaciones tecnológicas o de software en nuestro producto.



Advertencia: Para reducir el riesgo de lesiones, el usuario debe leer atentamente el manual de instrucciones.



Este producto está sujeto a la Directiva Europea 2012/19/CE. El símbolo de un contenedor de basura tachado indica que el producto requiere recogida selectiva de residuos en la Unión Europea. Esto aplica al producto y a todos los accesorios marcados con este símbolo. Los productos marcados con este símbolo no pueden desecharse con la basura doméstica normal, sino que deben llevarse a un punto de recogida para el reciclaje de aparatos eléctricos y electrónicos.

INSTRUCCIONES DE CABLEADO

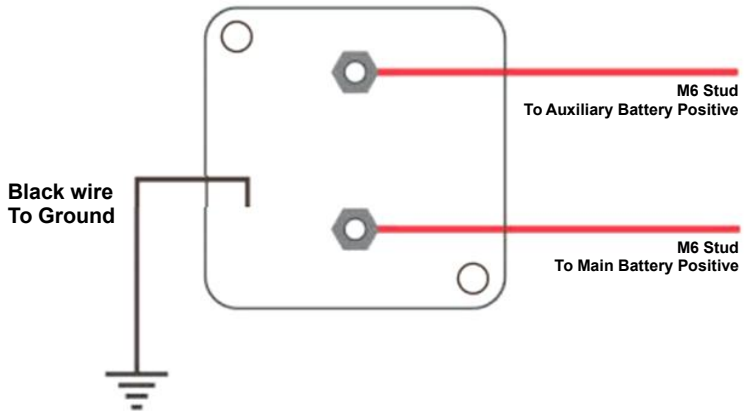

1. Introducción a la función

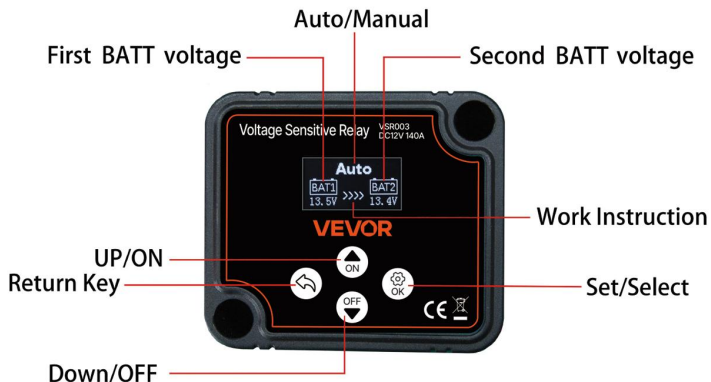

2. Función predeterminada

1. Después de conectar la batería, la pantalla mostrará el voltaje de AUTO, BATT1 y BATT2, el rango de visualización de voltaje es 4,5 V ~ 20 V.

2. Cuando el voltaje de entrada de la batería 1 excede los 13,3 V, el circuito de trabajo del aislador se conectará automáticamente y la pantalla mostrará

3. Cuando el voltaje de entrada baja a 12,7 V, el circuito se desconectará automáticamente. No mostrar

4. Conecte la batería principal con función de carga a BATT1; de lo contrario, el aislador no funcionará normalmente.

5. La pantalla se apagará automáticamente después de permanecer encendida durante 15 segundos y deberá presionar la tecla de configuración para encenderla nuevamente.

3. Protección contra alto y bajo voltaje

1. Cuando el voltaje de entrada es inferior a 11 V, el aislador se desconectará automáticamente y dejará de funcionar. Protege la batería principal contra daños por uso excesivo .

2. Cuando el voltaje de entrada es superior a 17 V, el circuito se desconectará automáticamente y dejará de funcionar para proteger la batería de daños.

4. Configuración de funciones

Mantenga presionado durante  3 segundos para ir a la página de inicio, el aislador está desconectado por defecto.

1. Estado automático a estado manual

Long press 3 Seconds



Click "OK"



Click select



Click back



Click "OK"



2. Ajuste del voltaje de funcionamiento

Long press 3 Seconds



Click select



Click "OK"



Click "OK"



3. Ajuste de retardo

Long press 3 Seconds



Click select



Click "OK"



Click "OK"



ESPECIFICACIONES TÉCNICAS

VOLTAJE	12 V
CORRIENTE DE CARGA	90-120 amperios CONTINUO, 160 AMPERIO CIMA
CONSUMO DE CORRIENTE	CARGA 330 mA, EN ESPERA 1 mA
VOLTAJE DE CORTE	13,3 V (ajustable)
TENSIÓN DE CORTE	12,7 V (ajustable)
RETARDO DE CORTE	3-5 SEGUNDOS (Ajustable)
CLASIFICACIÓN IP	IP67

Fabricante: Shanghai muxinmuyeyouxiangongsi

Dirección: Shuangchenglu 803nong11hao1602A-1609shi, baoshanqu, Shanghai 200000 CN.

Importado a AUS: SIHAO PTY LTD. 1 ROKEVA STREET EASTWOOD NSW 2122 Australia

Importado a EE. UU.: Sanven Technology Ltd. Suite 250, 9166 Anaheim Lugar, Rancho Cucamonga, CA 91730

UK	REP
-----------	------------

YH CONSULTING LIMITED. C/O YH Consulting Limited Office 147, Centurion House, London Road, Staines-upon-Thames, Surrey, TW18 4AX

EC	REP
-----------	------------

E-CrossStu GmbH
Mainzer Landstr.69,
60329 Frankfurt am Main.

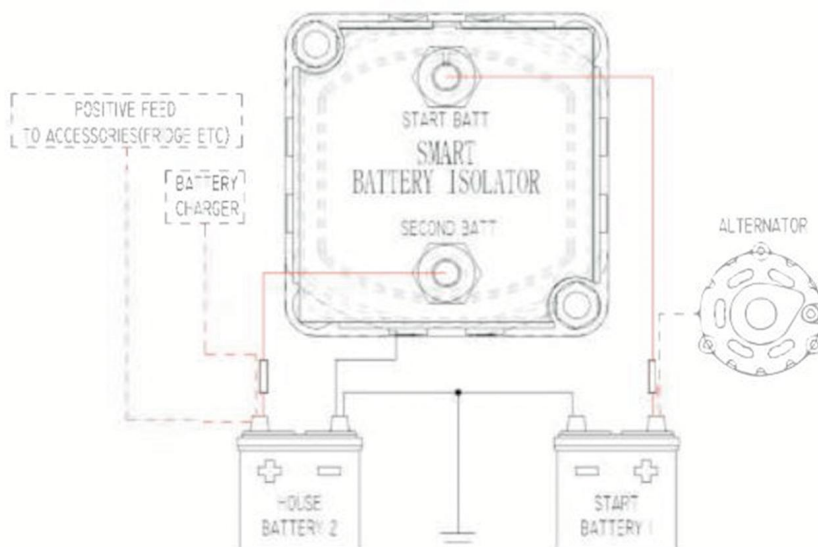

VSR003 -1 Lista de accesorios del kit

1. Relé sensible al voltaje *1
- de 2,6 AWG x 600 cm *1
- de batería negro de 3,5 AWG x 60 cm *1
4. 2 5- 8 Extremo del cable de terminal * 1
5. 16 - Extremos de cable de 8 orejetas * 2
- 6 . Terminal de anillo azul *1
7. Tubo termorretráctil rojo *2
- 8 . Tubo termorretráctil negro * 1
- 9 . Bridas para cables *6
- 10 . Tornillos M4 x 40 mm *2
- 11 . Tornillos M4 x 20 mm *2
- 1 2 . Terminales de batería *3



VEVOR

Affordable. Reliable. Home Improvement.

Przełącznik wrażliwy na napięcie

MODEL: VSR003, VSR003-1

VEVOR

Affordable. Reliable. Home Improvement.

MODEL: VSR003, VSR003-1



(Zdjęcie ma charakter poglądowy, prosimy odnosić się do rzeczywistego obiektu)

To jest oryginalna instrukcja obsługi. Przed użyciem prosimy o dokładne zapoznanie się z treścią instrukcji. Firma VEVOR zastrzega sobie prawo do jednoznacznej interpretacji niniejszej instrukcji obsługi. Wygląd produktu zależy od stanu, w jakim go otrzymali Państwo. Prosimy o wyrozumiałość, ale nie będziemy Państwa ponownie informować o aktualizacjach technologicznych lub oprogramowania naszego produktu.



Ostrzeżenie: Aby zminimalizować ryzyko obrażeń, użytkownik powinien uważnie przeczytać instrukcję obsługi.



Niniejszy produkt podlega przepisom Dyrektywy Europejskiej 2012/19/WE. Symbol przedstawiający przekreślony kosz na śmieci na kółkach oznacza, że produkt wymaga selektywnej zbiórki odpadów w Unii Europejskiej. Dotyczy to produktu i wszystkich akcesoriów oznaczonych tym symbolem. Produktów oznaczonych tym symbolem nie można wyrzucać razem z normalnymi odpadami domowymi, lecz należy je dostarczyć do punktu zbiórki urządzeń elektrycznych i elektronicznych przeznaczonych do recyklingu.

INSTRUKCJA OKABLOWANIA

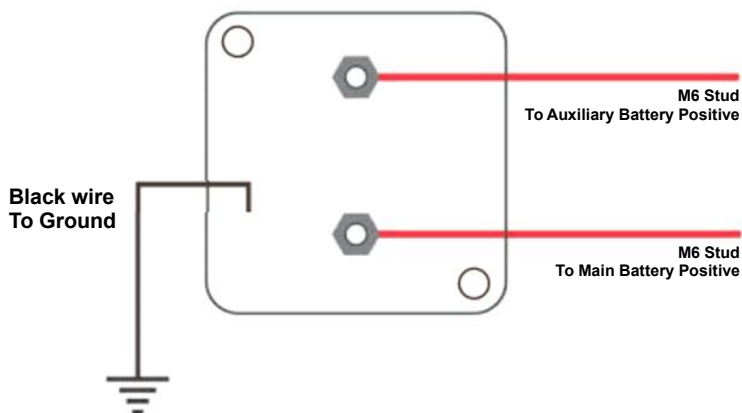

1. Wprowadzenie do funkcji

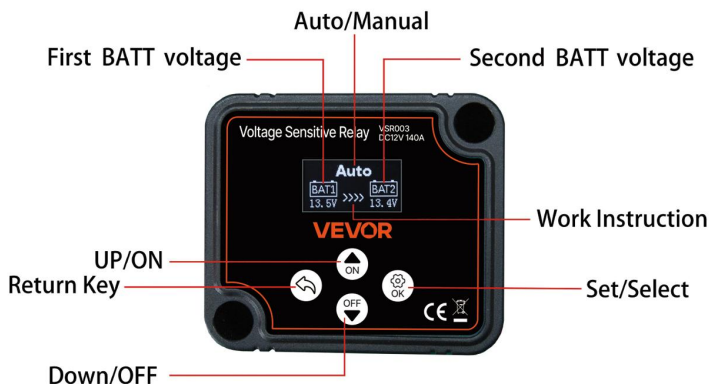

2. Funkcja domyślna

1. Po podłączeniu akumulatora na wyświetlaczu pojawi się napięcie AUTOMATYCZNY, BATT1 i BATT2. Zakres wyświetlania napięcia wynosi 4,5 V~20 V.

2. Gdy napięcie wejściowe akumulatora 1 przekroczy 13,3 V, obwód roboczy izolatora zostanie automatycznie włączony, a na ekranie wyświetlacza pojawi się komunikat

3. Gdy napięcie wejściowe spadnie do 12,7 V, obwód zostanie automatycznie rozłączony. Nie wyświetlacz

4. Proszę podłączyć główny akumulator z funkcją ładowania do BATT1. W przeciwnym razie izolator nie będzie działał prawidłowo.

5. Wyświetlacz wyłączy się automatycznie po upływie 15 sekund od włączenia. Aby go ponownie włączyć, należy nacisnąć przycisk ustawień.

3. Ochrona przed wysokim i niskim napięciem

1. Gdy napięcie wejściowe spadnie poniżej 11 V, izolator automatycznie się rozłączy i przestanie działać. Chroni główny akumulator przed uszkodzeniem w wyniku nadmiernego użytkowania .

2. Gdy napięcie wejściowe jest wyższe niż 17 V, układ automatycznie się rozłączy i przestanie działać. Chroni to akumulator przed uszkodzeniem.

4. Ustawienia funkcji

Długie naciśnięcie przez  3 sekundy powoduje przejście do strony głównej. Izolator jest domyślnie odłączony.

1. Stan automatyczny na stan ręczny

Long press 3 Seconds



Click "OK"



Click select



Click back



Click "OK"



2. Ustawienie napięcia roboczego

Long press 3 Seconds



Click select



Click "OK"



Click "OK"



3. Ustawienie opóźnienia

Long press 3 Seconds



Click select



Click "OK"



Click "OK"



DANE TECHNICZNE

WOLTAŻ	12V
PRĄD ŁADOWANIA	90-120 A CIĄGŁY, 160 AMP SZCZYT
AKTUALNE POBIERANIE	ŁADOWANIE 330 mA, CZUJNOŚĆ 1 mA
NAPIĘCIE ZAŁĄCZENIA	13,3 V (regulowane)
NAPIĘCIE WYŁĄCZENIA	12,7 V (regulowane)
OPÓŹNIENIE WYŁĄCZENIA	3-5 SEKUND (regulowane)
WSPÓŁCZYNNIK OCHRONY IP	IP67

Producent: Shanghaimuxinmuyeyouxiangongsi

Adres: Shuangchenglu 803nong11hao1602A-1609shi, baoshanqu, szanghaj 200000 CN.

Importowane do AUS: SIHAO PTY LTD. 1 ROKEVA
STREETEASTWOOD
NSW 2122 Australia

Importowane do USA: Sanven Technology Ltd. Suite 250, 9166 Anaheim
Miejsce, Rancho Cucamonga, CA 91730

UK	REP
-----------	------------

YH CONSULTING LIMITED. C/O YH Consulting
Limited Office 147, Centurion House, London
Road, Staines-upon-Thames, Surrey, TW18 4AX

EC	REP
-----------	------------

E-CrossStu GmbH
Mainzer Landstr.69,
60329 Frankfurt am Main.

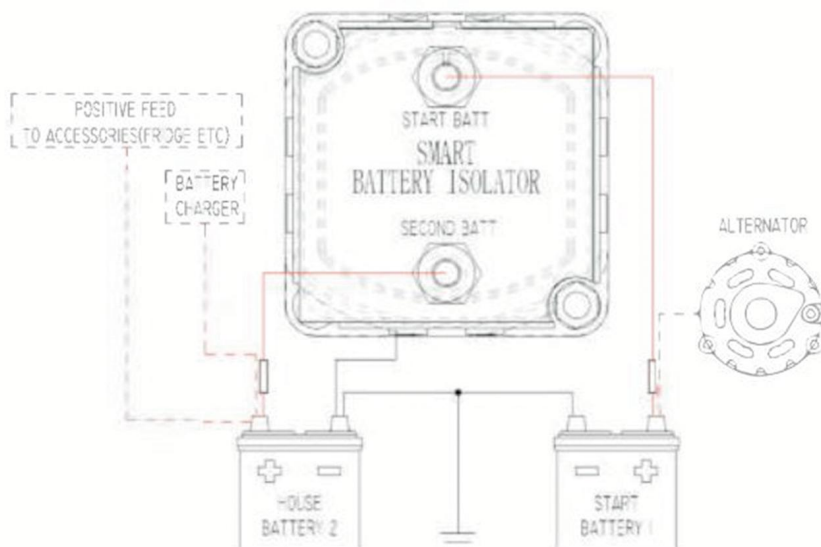

VSR003 -1 Lista akcesoriów do zestawu

1. Przełącznik wrażliwy na napięcie *1
2. 6 AWG x 600 cm czerwony kabel akumulatorowy *1
3. 5 AWG x 60 cm Czarny kabel akumulatorowy *1
4. 2 5- 8 Końcówka kabla z końcówką * 1
5. 16 - 8 końcówek kabli oczkowych * 2
6. Niebieski zacisk pierścieniowy *1
7. Czerwona rurka termokurczliwa *2
- 8 . Czarna rurka termokurczliwa * 1
- 9 . Opaski kablowe *6
- 10 . Śruby M4 x 40 mm *2
- 11 . Śruby M4 x 20 mm *2
- 1 2 . Zaciski akumulatora *3



VEVOR

Affordable. Reliable. Home Improvement.

Spanningsgevoelig relais

MODEL: VSR003, VSR003-1

VEVOR

Affordable. Reliable. Home Improvement.

MODEL: VSR003, VSR003-1



(De afbeelding is alleen ter referentie, raadpleeg het daadwerkelijke object)

Dit is de originele handleiding. Lees alle instructies zorgvuldig door voordat u het product gebruikt. VEVOR behoudt zich het recht voor om de gebruiksaanwijzing duidelijk te interpreteren. Het uiterlijk van het product is afhankelijk van het product dat u hebt ontvangen. Neemt u het ons niet kwalijk dat we u niet meer op de hoogte stellen van eventuele technologische of software-updates voor ons product.



Waarschuwing: om het risico op letsel te verminderen, moet de gebruiker de gebruiksaanwijzing zorgvuldig lezen.



Dit product valt onder de bepalingen van de Europese Richtlijn 2012/19/EG. Het symbool met een doorgekruiste vuilnisbak geeft aan dat het product in de Europese Unie gescheiden afvalinzameling vereist. Dit geldt voor het product en alle accessoires die met dit symbool zijn gemarkeerd. Producten die als zodanig zijn gemarkeerd, mogen niet met het normale huisvuil worden weggegooid, maar moeten worden ingeleverd bij een inzamelpunt voor de recycling van elektrische en elektronische apparaten.

BEDRADINGINSTRUCTIES

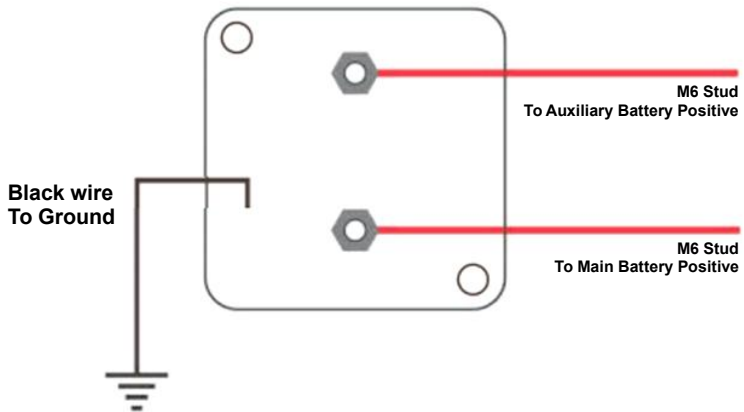

1. Functie-introductie

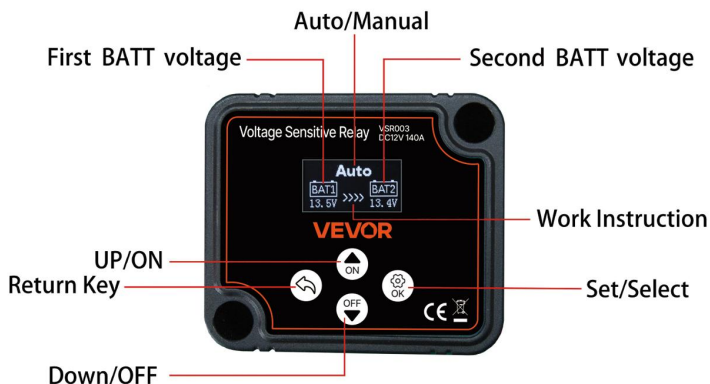

2. Standaardfunctie

1. Nadat u de batterij hebt aangesloten, wordt op het display de spanning weergegeven AUTO, BATT1 en BATT2, het spanningsweergavebereik is 4,5V~20V.

2. Wanneer de ingangsspanning van batterij 1 13,3 V overschrijdt, wordt het werkcircuit van de isolator automatisch ingeschakeld en wordt op het display weergegeven

3. Wanneer de ingangsspanning daalt tot 12,7 V, wordt het circuit automatisch uitgeschakeld. weergave

4. Sluit de hoofdaccu met laadfunctie aan op BATT1, anders werkt de isolator niet normaal.

5. Het display schakelt automatisch uit nadat het 15 seconden aan is geweest. U moet op de insteltoets drukken om het weer in te schakelen.

3. Bescherming tegen hoge spanning en lage spanning

1. Wanneer de ingangsspanning lager is dan 11 V, schakelt de isolator automatisch uit en stopt met werken. Bescherm de hoofdaccu tegen beschadiging door overbelasting .

2. Wanneer de ingangsspanning hoger is dan 17V, wordt het circuit automatisch losgekoppeld en stopt met werken. Bescherm de accu tegen schade.

4. Functie-instelling



Houd de knop 3 seconden ingedrukt om naar de startpagina te gaan. De isolator is standaard uitgeschakeld.

1. Automatische toestand naar handmatige toestand

Long press 3 Seconds



Click "OK"



Click select



Click back



Click "OK"



2. Bedrijfsspanningsinstelling

Long press 3 Seconds



Click select



Click "OK"



Click "OK"



3. Vertraging instellen

Long press 3 Seconds



Click select



Click "OK"



Click "OK"



TECHNISCHE SPECIFICATIES

SPANNING	12V
LAADSTROOM	90-120 AMP CONTINU, 160 AMP PIEK
HUIDIGE TREKKING	OPLADEN 330mA, STAND-BY 1mA
INSCHAKELSPANNING	13,3V (instelbaar)
UITSCHAKELSPANNING	12. 7 V (instelbaar)
UITSCHAKELVERTRAGING	3-5 SECONDEN (instelbaar)
IP-classificatie	IP67

Fabrikant: Shanghaimuxinmuyeyouxiangongsi

Adres: Shuangchenglu 803nong11hao1602A-1609shi, baoshanqu, shanghai 200000 CN.

Geïmporteerd naar AUS: SIHAO PTY LTD. 1 ROKEVA STREETEASTWOOD NSW 2122 Australië

Geïmporteerd naar de VS: Sanven Technology Ltd. Suite 250, 9166 Anaheim

Plaats, Rancho Cucamonga, CA 91730

UK	REP
-----------	------------

YH CONSULTING LIMITED. C/O YH Consulting Limited Office 147, Centurion House, London Road, Staines-upon-Thames, Surrey, TW18 4AX

EC	REP
-----------	------------

E-CrossStu GmbH Mainzer Landstr.69, 60329 Frankfurt am Main.

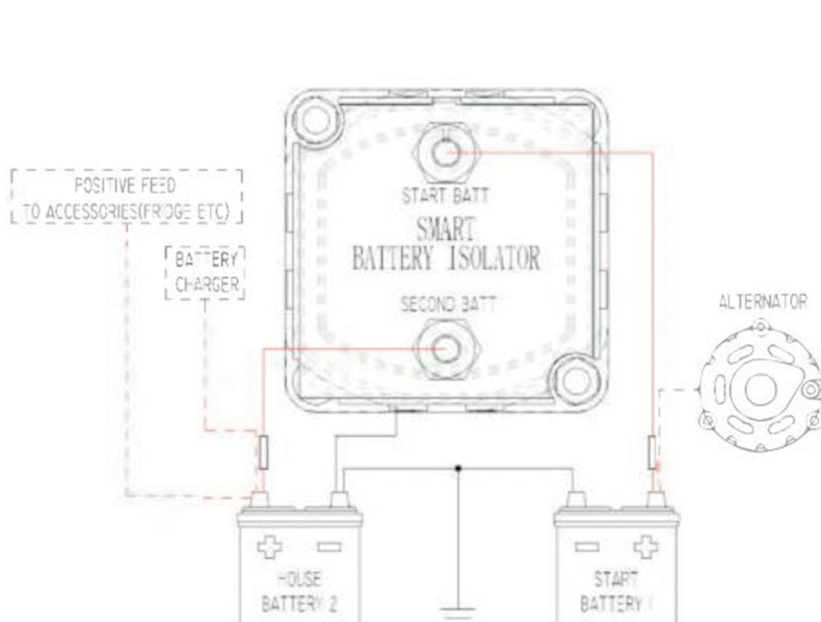

VSR003 -1 Lijst met kitaccessoires

1. Spanningsgevoelig relais *1
2. 6 AWG x 600 cm rode batterijkabel *1
- 3,5 AWG x 60 cm zwarte batterijkabel * 1
- 4 . 2 5- 8 Lug Kabeluiteinde * 1
5. 16 - 8- oog kabeluiteinde s * 2
6. Blauwe ringterminal *1
7. Rode krimpkous *2
- 8 . Zwarte krimpkous * 1
- 9 . Kabelbinders *6
- 10 . M4 x 40mm schroeven *2
- 11 . M4 x 20mm schroeven *2
- 1 2 . Batterijklemmen *3



VEVOR

Affordable. Reliable. Home Improvement.

Spänningskänsligt relä

MODELL: VSR003, VSR003-1

VEVOR

Affordable. Reliable. Home Improvement.

MODELL: VSR003, VSR003-1



(Bilden är endast för referens, vänligen hänvisa till det faktiska objektet)

Detta är originalinstruktionerna, vänligen läs alla instruktioner noggrant innan du använder produkten. VEVOR förbehåller sig en tydlig tolkning av vår användarmanual. Produktens utseende ska vara beroende av den produkt du mottagit. Vi ber om ursäkt för att vi inte kommer att informera dig igen om det finns några teknik- eller programuppdateringar för vår produkt.



Varning – För att minska risken för skador måste användaren läsa instruktionsmanualen noggrant.



Denna produkt omfattas av bestämmelserna i EU-direktiv 2012/19/EG. Symbolen som visar en överstruken soptunna indikerar att produkten kräver separat sophämtning inom Europeiska unionen. Detta gäller produkten och alla tillbehör som är märkta med denna symbol. Produkter som är märkta som sådana får inte kasseras med vanligt hushållsavfall, utan måste lämnas till en samlingsplats för återvinning av elektriska och elektroniska apparater.

KABELDRAGNINGSDIAGRAM

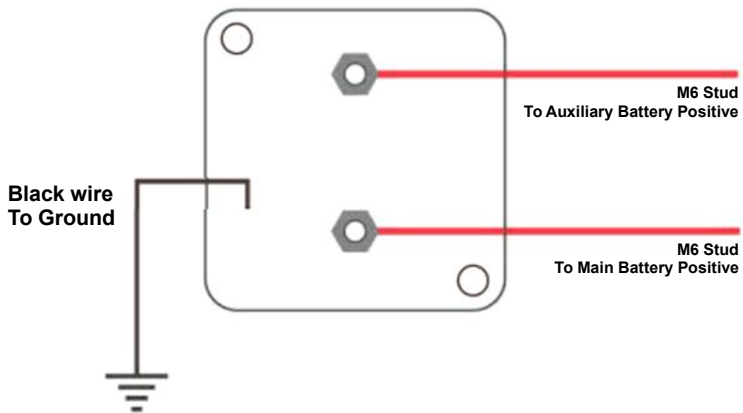

1. Funktionsintroduktion

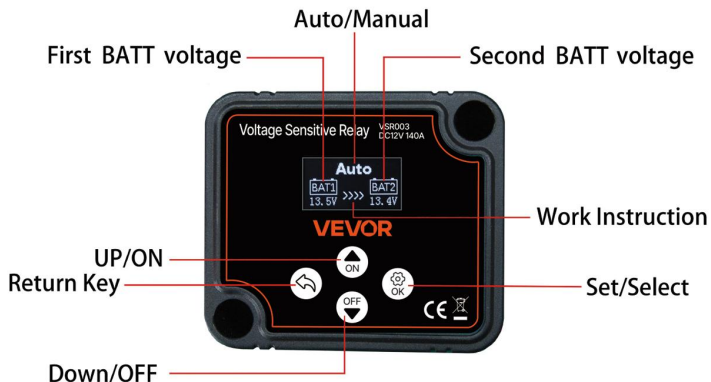

2. Standardfunktion

1. Efter att batteriet anslutits visar skärmen spänningen för BIL, BATT1 och BATT2, Spänningsvisningsområdet är 4,5V~20V.
2. När ingångsspänningen för batteri 1 överstiger 13,3 V, kommer isolatorns arbetskrets automatiskt att slås på och skärmen visar
3. När ingångsspänningen sjunker till 12,7 V, kommer kretsen att kopplas bort automatiskt. Gör inte visa

4. Anslut huvudbatteriet med laddningsfunktion till BATT1, annars fungerar inte isolatorn normalt.

5. Skärmen stängs av automatiskt efter att ha varit påslagen i 15 sekunder. Du måste trycka på inställningsknappen för att slå på den igen.

3. Högsänning, lågsänningsskydd

1. När ingångsspänningen är lägre än 11 V, kopplas isolatorn automatiskt bort och slutar fungera. Skydda huvudbatteriet från att skadas av överanvändning .
2. När ingångsspänningen är högre än 17 V kopplas kretsen automatiskt bort och slutar fungera. Skydda batteriet från skador.

4. Funktionsinställning



Långt tryck  i 3 sekunder, gå till startsidan, isolatorn är frångkopplad som standard.

1. Automatiskt tillstånd till manuellt tillstånd

Long press 3 Seconds



Click "OK"



Click select



Click "OK"



Click back



2. Inställning av driftspänning

Long press 3 Seconds



Click select



Click "OK"



Click "OK"



3. Fördröjningsinställning

Long press 3 Seconds



Click select



Click "OK"



Click "OK"



TEKNISKA SPECIFIKATIONER

SPÄNNING	12V
LADDNINGSSTRÖM	90–120 Ampere KONTINUERLIG, 160 AMP TOPP
NUVARANDE DRAGNING	LADDNING 330mA, STANDBY 1mA
INGÅNGSSPÄNNING	13,3 V (justerbar)
AVBRYTNINGSSPÄNNING	12,7 V (Justerbar)
AVSTÄNGNINGSFÖRDRÖJNING	3–5 SEKUNDER (justerbar)
IP-KLASSNING	IP67

Tillverkare: Shanghaimuxinmuyeyouxiangongsi

Adress: Shuangchenglu 803nong11hao1602A-1609shi, baoshanqu, Shanghai 200 000 kanadensiska republiken.

Importerad till Australien: SIHAO PTY LTD. 1 ROKEVA STREETEASTWOOD NSW 2122 Australien

Importerad till USA: Sanven Technology Ltd. Suite 250, 9166 Anaheim Plats, Rancho Cucamonga, Kalifornien 91730

UK	REP
-----------	------------

YH CONSULTING LIMITED. C/O YH Consulting Limited Office 147, Centurion House, London Road, Staines-upon-Thames, Surrey, TW18 4AX

EC	REP
-----------	------------

E-CrossStu GmbH Mainzer Landstr.69, 60329 Frankfurt am Main.

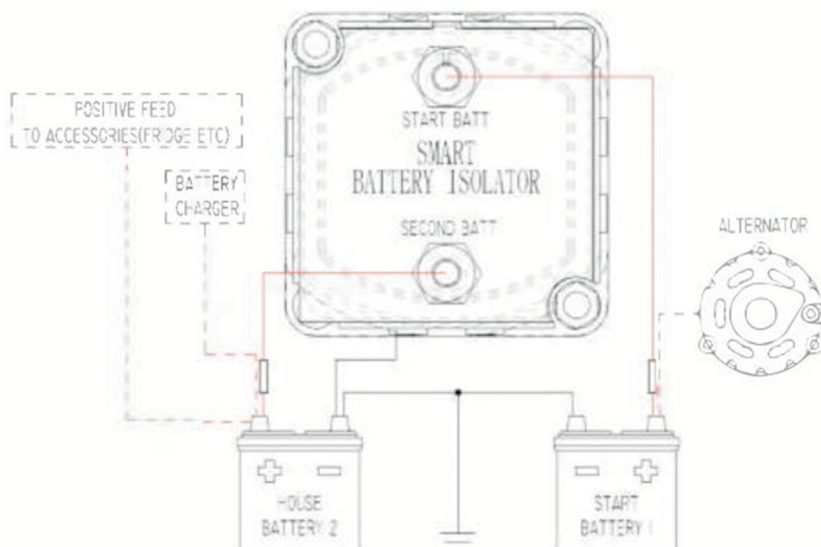

VSR003 -1 Lista över tillbehör till kit

1. Spänningskänsligt relä *1
2. 6 AWG x 600 cm röd batterikabel * 1
- 3,5 AWG x 60 cm svart batterikabel * 1
4. 2 5-8 kabelände * 1
5. 16 - 8 kabeländar * 2
6. Blå ringterminal *1
7. Röd krympslang *2
- 8 . Svart krympslang * 1
- 9 . Kabelband *6
- 10 . M4 x 40 mm skruvar *2
- 11 . M4 x 20 mm skruvar *2
- 1 2 . Batteripoler *3

