

VEVOR[®]

TOUGH TOOLS, HALF PRICE

Technical Support and E-Warranty Certificate

www.vevor.com/support

DIVIDING HEAD

MODEL: BS4-KP100-57

We continue to be committed to provide you tools with competitive price.

"Save Half", "Half Price" or any other similar expressions used by us only represents an estimate of savings you might benefit from buying certain tools with us compared to the major top brands and does not necessarily mean to cover all categories of tools offered by us. You are kindly reminded to verify carefully when you are placing an order with us if you are actually saving half in comparison with the top major brands.

VEVOR[®]

TOUGH TOOLS, HALF PRICE

DIVIDING HEAD

MODEL: BS4-KP100-57



NEED HELP? CONTACT US!

Have product questions? Need technical support? Please feel free to contact us:

Technical Support and E-Warranty Certificate
www.vevor.com/support

This is the original instruction, please read all manual instructions carefully before operating. VEVOR reserves a clear interpretation of our user manual. The appearance of the product shall be subject to the product you received. Please forgive us that we won't inform you again if there are any technology or software updates on our product.



Warning-To reduce the risk of injury, user must read instructions manual carefully.

MAINTENANCE INSTRUCTIONS

1. In order to ensure that the machine chuck still has good accuracy after being used for a long time, lubrication is very important.
2. Molybdenum disulfide grease (black in color) needs to be applied after each shift, and the grease is poured into the jaws of the chuck until the grease overflows the jaw surface or the inner hole of the chuck, but if the chuck is highly rotated or has a large amount of water When cutting oil is used for processing, it needs more lubrication, which must be determined according to different situations.
3. Be sure to use an air gun or similar tools to clean the chuck body and the slide surface when the operation is completed.
4. Remove the chuck at least every 6 months for disassembly and cleaning, and keep the sliding surface of the jaws clean and lubricated so that the life of the chuck is prolonged. However, if the cutting cast iron is thoroughly cleaned at least once or several times every 2 months, check the parts for cracks and wear and replace them with new ones immediately. After the inspection is completed, it must be fully oiled before assembly.
5. The use of cutting oil with an anti-rust effect can prevent rust inside the chuck because the rust of the chuck will reduce the clamping force, and the workpiece cannot be clamped.

INSTRUCTIONS

1. First of all, it is necessary to confirm whether the workpiece to be processed needs a positive claw or a reverse claw. The positive claw can hold a solid workpiece with a diameter of 48 mm and a hollow pipe of 100mm, and the reverse claw can hold a workpiece with a diameter of 112mm. The replacement steps are as follows.:

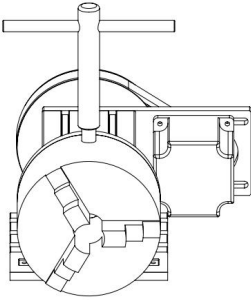
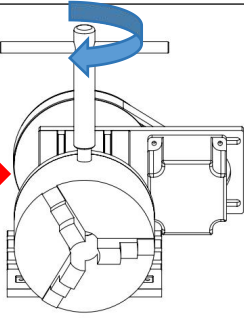
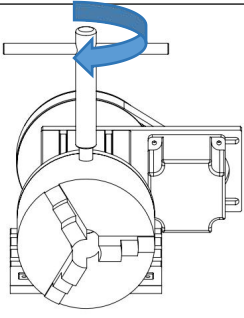
<p>Insert the chuck wrench into the chuck</p>	<p>Rotate the chuck wrench counterclockwise to take out the front and back jaws</p>	<p>Rotate the chuck wrench clockwise to install the front and back jaws</p>
		

2. Fix the chuck to the processing table and clamp the workpiece to be processed.

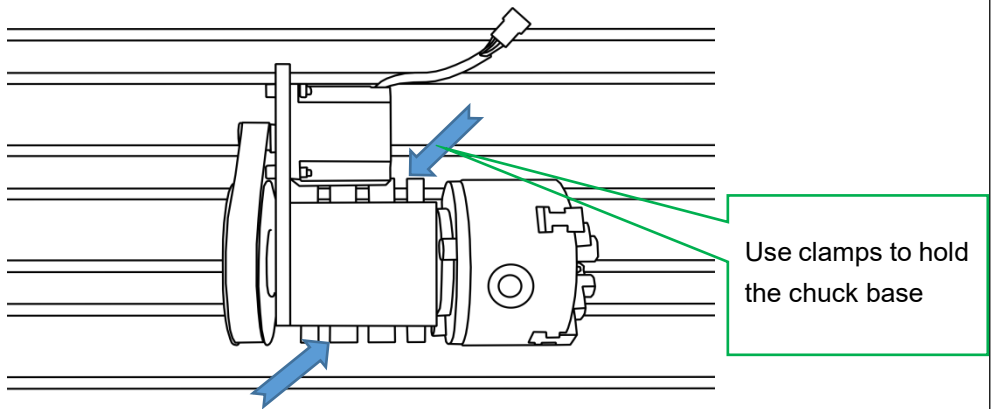

3. Insert and lock both ends of the cable respectively.

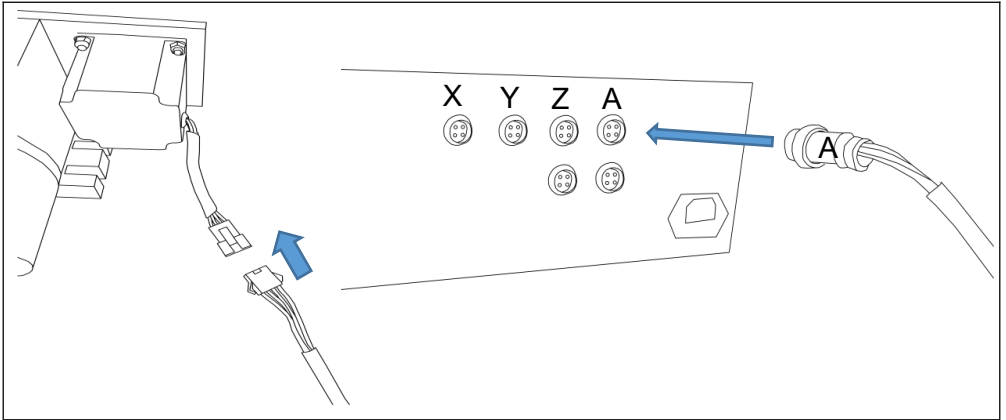

4. When the above work is ready, you can start processing. The screws in the accessories are spare screws and do not need to be used unless there are special circumstances.

K11-100 HEAD PARAMETER TABLE

Card plate model	K11-100 three-claw self-centering chuck
Clip tight range	2-80mm
Hold tight range	30-90mm
Custody precision	0.05mm
center height	65mm
highness	117MM
Drive the motor	57 stepper motor, 2-phase 3A 57 stepper motor; 57 * 57 * 76MM; 4 lead
gear ratio	6:1; (Belt deceleration mode)

LIST OF ACCESSORIES

sequence number	Accessories name	number of packages
1	Dividing Head(with chuck)	1
2	Rotate the thimble, MT2	1
3	Numerical control cable	1
4	chuck handle	1
5	Card plate anti-claw	3
6	Tailstock	1

Manufacturer: Shanghaimuxinmuyeyouxiangongsi

Address: Shuangchenglu 803nong11hao1602A-1609shi, baoshanqu, shanghai 200000 CN.

Imported to AUS: SIHAO PTY LTD, 1 ROKEVA STREETEASTWOOD NSW 2122 Australia

Imported to USA: Sanven Technology Ltd., Suite 250, 9166 Anaheim Place, Rancho Cucamonga, CA 91730

EC	REP
-----------	------------

E-CrossStu GmbH
Mainzer Landstr.69, 60329 Frankfurt am Main.

UK	REP
-----------	------------

YH CONSULTING LIMITED.
C/O YH Consulting Limited Office 147, Centurion House,
London Road, Staines-upon-Thames, Surrey, TW18 4AX

VEVOR[®]

TOUGH TOOLS, HALF PRICE

Technical Support and E-Warranty Certificate

www.vevor.com/support

VEVOR[®]

TOUGH TOOLS, HALF PRICE

Technique Certificat d'assistance et de garantie électronique

www.vevor.com/support

TÊTE DE DIVISION

MODÈLE : BS4-KP100-57

We continue to be committed to provide you tools with competitive price.

"Save Half", "Half Price" or any other similar expressions used by us only represents an estimate of savings you might benefit from buying certain tools with us compared to the major top brands and does not necessarily mean to cover all categories of tools offered by us. You are kindly reminded to verify carefully when you are placing an order with us if you are actually saving half in comparison with the top major brands.

VEVOR®

TOUGH TOOLS, HALF PRICE

DIVIDING HEAD

MODÈLE : BS4-KP100-57



NEED HELP? CONTACT US!

Have product questions? Need technical support? Please feel free to contact us:

Technical Support and E-Warranty Certificate
www.vevor.com/support

This is the original instruction, please read all manual instructions carefully before operating. VEVOR reserves a clear interpretation of our user manual. The appearance of the product shall be subject to the product you received. Please forgive us that we won't inform you again if there are any technology or software updates on our product.



Avertissement - Pour réduire le risque de blessure, l'utilisateur doit lire attentivement le manuel d'instructions.

MAINTENANCE INSTRUCTIONS

1. Afin de garantir que le mandrin de la machine conserve une bonne précision après une utilisation prolongée, la lubrification est très importante.
2. La graisse au bisulfure de molybdène (de couleur noire) doit être appliquée après chaque quart de travail et la graisse est versée dans les mâchoires du mandrin jusqu'à ce que la graisse déborde de la surface de la mâchoire ou du trou intérieur du mandrin, mais si le mandrin est fortement tourné ou a une grande quantité d'eau Lorsque l'huile de coupe est utilisée pour le traitement, elle nécessite plus de lubrification, ce qui doit être déterminé en fonction de différentes situations.
3. Assurez-vous d'utiliser un pistolet à air comprimé ou des outils similaires pour nettoyer le corps du mandrin et la surface coulissante une fois l'opération terminée.
4. Retirez le mandrin au moins tous les 6 mois pour le démonter et le nettoyer, et maintenez la surface coulissante des mâchoires propre et lubrifiée afin de prolonger la durée de vie du mandrin. Cependant, si la fonte de coupe est soigneusement nettoyée au moins une ou plusieurs fois tous les 2 mois, vérifiez que les pièces ne présentent pas de fissures et d'usure et remplacez-les immédiatement par des neuves. Une fois l'inspection terminée, elle doit être entièrement huilée avant le montage.
5. L'utilisation d'huile de coupe avec un effet antirouille peut empêcher la rouille à l'intérieur du mandrin car la rouille du mandrin réduira la force de serrage et la pièce ne pourra pas être serrée.

INSTRUCTIONS

2. Tout d'abord, il faut vérifier si la pièce à usiner nécessite une griffe positive ou une griffe inversée. La griffe positive peut maintenir une pièce

solide d'un diamètre de 48 mm et un tube creux de 100 mm, et la griffe inversée peut maintenir une pièce d'un diamètre de 112 mm. Les étapes de remplacement sont les suivantes :

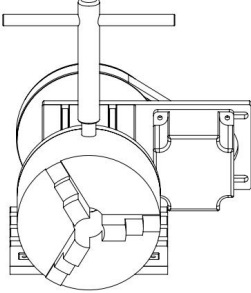
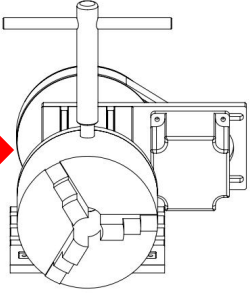
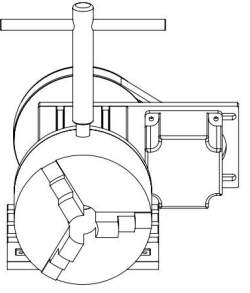
<p>Insérez la clé à mandrin dans le mandrin</p>	<p>Tournez la clé à mandrin dans le sens inverse des aiguilles d'une montre pour retirer les mâchoires avant et arrière</p>	<p>Tournez la clé à mandrin dans le sens des aiguilles d'une montre pour installer les mâchoires avant et arrière</p>
		

2. Fixez le mandrin sur la table d'usinage et serrez la pièce à usiner.

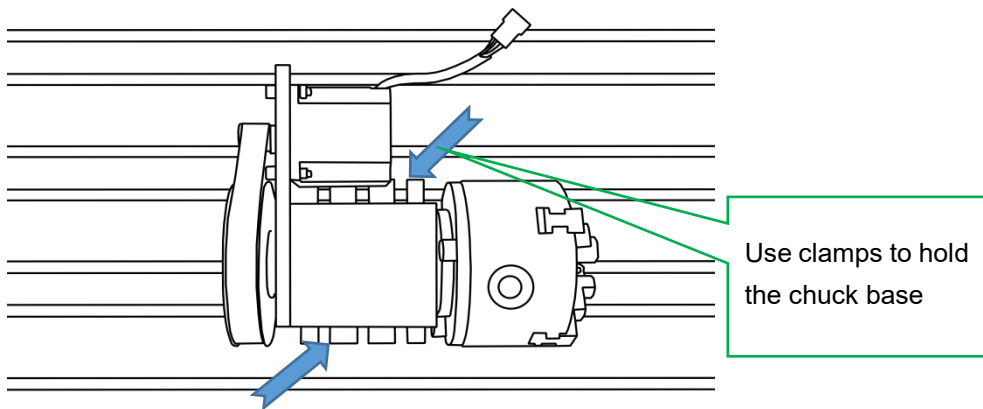

3. Insérez et verrouillez respectivement les deux extrémités du câble.

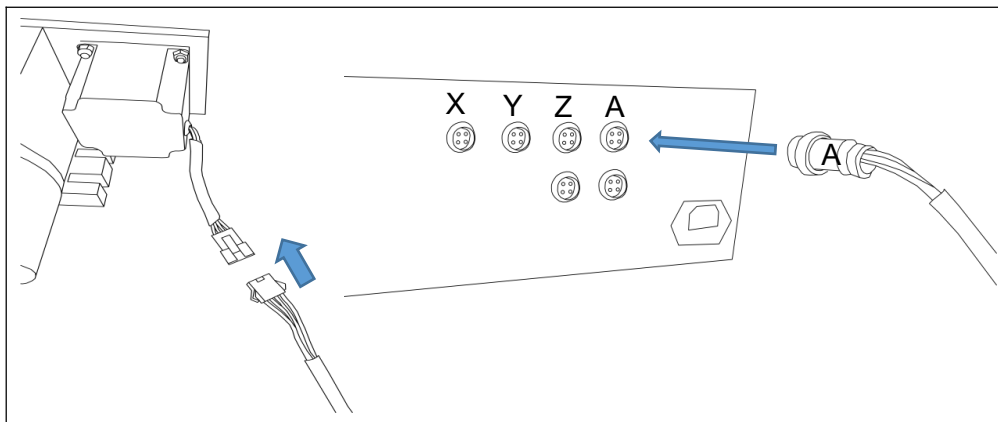

4. Une fois le travail ci-dessus terminé, vous pouvez commencer le traitement. Les vis des accessoires sont des vis de rechange et n'ont pas besoin d'être utilisées sauf circonstances particulières.

K11-100 HEAD PARAMETER TABLE

Modèle de plaque de carton	Mandrin autocentrant à trois griffes K11-100
Plage de serrage des clips	2-80 mm
Tenez-vous bien à portée	30-90 mm
Précision de la garde	0,05 mm
hauteur centrale	65 mm
altesse	117MM
Conduire le moteur	Moteur pas à pas 57, 2 phases 3A Moteur pas à pas 57 ; 57 * 57 * 76MM ; 4 fils
rapport de démultiplication	6:1; (Mode de décélération de la courroie)

LIST OF ACCESSORIES

numéro de séquence	Nom des accessoires	nombre de colis
1	Tête de division (avec mandrin)	1
2	Faire tourner le dé à coudre, MT2	1
3	Câble de commande numérique	1
4	poignée de mandrin	1
5	Plaque à cartes anti-griffes	3
6	Contre-pointe	1

Fabricant : Shanghaimuxinmuyeyouxiangongsi

Adresse : Shuangchenglu 803nong11hao1602A-1609shi, baoshanqu, shanghai 200000 CN.

Importé en Australie : SIHAO PTY LTD, 1 ROKEVA STREET, ASTWOOD NSW 2122 Australie

Importé aux États-Unis : Sanven Technology Ltd., Suite 250, 9166 Anaheim Place, Rancho Cucamonga, CA 91730

EC	REP
-----------	------------

E-CrossStu GmbH
Mainzer Landstr.69, 60329 Frankfurt am Main.

UK	REP
-----------	------------

YH CONSULTING LIMITED.
C/O YH Consulting Limited Office 147, Centurion House,
London Road, Staines-upon-Thames, Surrey, TW18 4AX

VEVOR[®]

TOUGH TOOLS, HALF PRICE

Technique Certificat d'assistance et de garantie électronique

www.vevor.com/support

VEVOR[®]

TOUGH TOOLS, HALF PRICE

Technisch Support und E-Garantie-Zertifikat
www.vevor.com/support

TEILAPPARAT

MODELL: BS4-KP100-57

We continue to be committed to provide you tools with competitive price.

"Save Half", "Half Price" or any other similar expressions used by us only represents an estimate of savings you might benefit from buying certain tools with us compared to the major top brands and does not necessarily mean to cover all categories of tools offered by us. You are kindly reminded to verify carefully when you are placing an order with us if you are actually saving half in comparison with the top major brands.

VEVOR®

TOUGH TOOLS, HALF PRICE

DIVIDING HEAD

MODELL: BS4-KP100-57



NEED HELP? CONTACT US!

Have product questions? Need technical support? Please feel free to contact us:

Technical Support and E-Warranty Certificate
www.vevor.com/support

This is the original instruction, please read all manual instructions carefully before operating. VEVOR reserves a clear interpretation of our user manual. The appearance of the product shall be subject to the product you received. Please forgive us that we won't inform you again if there are any technology or software updates on our product.



Warnung: Um das Verletzungsrisiko zu verringern, muss der Benutzer die Bedienungsanleitung sorgfältig lesen.

MAINTENANCE INSTRUCTIONS

1. Um sicherzustellen, dass das Maschinenfutter auch nach längerem Gebrauch noch eine gute Genauigkeit aufweist, ist die Schmierung sehr wichtig.
2. Nach jedem Wechsel muss Molybdändisulfidfett (schwarz) aufgetragen und in die Backen des Spannfutters gegossen werden, bis das Fett über die Backenoberfläche oder das innere Loch des Spannfutters läuft. Wenn das Spannfutter jedoch stark rotiert oder eine große Menge Wasser enthält, ist bei der Verarbeitung mit Schneidöl mehr Schmierung erforderlich, was je nach Situation bestimmt werden muss.
Gleitfläche nach Abschluss des Vorgangs unbedingt mit einer Druckluftpistole oder einem ähnlichen Werkzeug .
4. Entfernen Sie das Spannfutter mindestens alle 6 Monate zum Zerlegen und Reinigen und halten Sie die Gleitfläche der Backen sauber und geschmiert, damit die Lebensdauer des Spannfutters verlängert wird. Wenn das Schneidgusseisen jedoch mindestens einmal oder mehrmals alle 2 Monate gründlich gereinigt wird, überprüfen Sie die Teile auf Risse und Verschleiß und ersetzen Sie sie sofort durch neue. Nach Abschluss der Inspektion muss es vor der Montage vollständig geölt werden.
5. Die Verwendung von Schneidöl mit Rostschutzwirkung kann Rost im Inneren des Spannfutters verhindern, da der Rost im Spannfutter die Spannkraft verringert und das Werkstück nicht geklemmt werden kann.

INSTRUCTIONS

3. Zunächst muss festgestellt werden, ob das zu bearbeitende Werkstück eine positive Klaue oder eine umgekehrte Klaue benötigt. Die positive Klaue kann ein festes Werkstück mit einem Durchmesser von 48 halten mm und ein Hohlrohr von 100 mm, und die umgekehrte Klaue kann ein

Werkstück mit einem Durchmesser von 112 mm halten. Die Austauschschritte sind wie folgt:

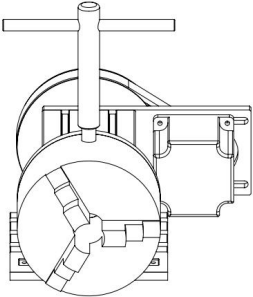
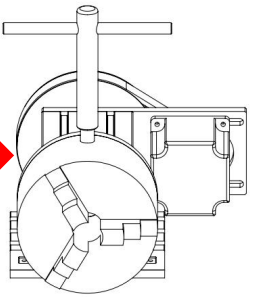
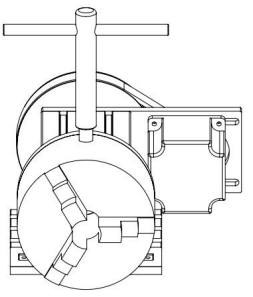
<p>Den Bohrfutterschlüssel in das Bohrfutter einsetzen</p>	<p>Drehen Sie den Spanschlüssel gegen den Uhrzeigersinn, um die Vorder- und Hinterbacken herauszunehmen</p>	<p>Drehen Sie den Spanschlüssel im Uhrzeigersinn, um die Vorder- und Hinterbacken zu montieren</p>
		

2. Spannfutter auf dem Bearbeitungstisch fixieren und das zu bearbeitende Werkstück einspannen.

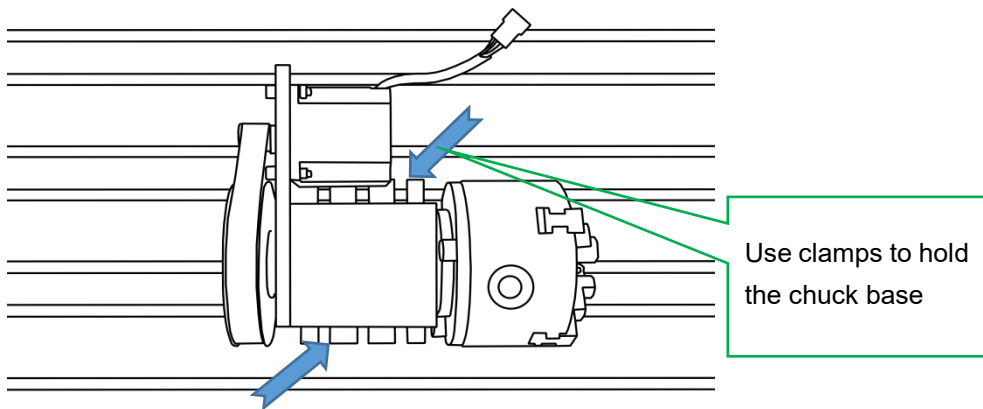

3. Beide Enden des Kabels einstecken und verriegeln.

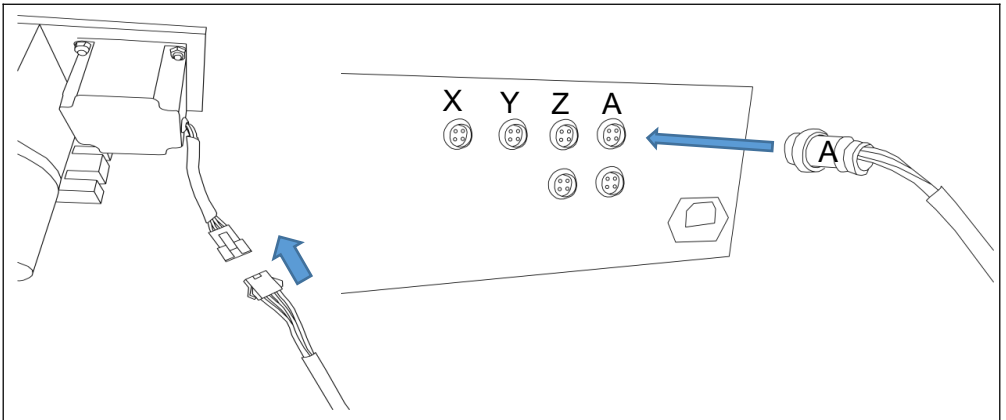

4. Wenn die oben genannten Arbeiten abgeschlossen sind, können Sie mit der Verarbeitung beginnen. Die Schrauben im Zubehör sind Ersatzschrauben und müssen nur unter besonderen Umständen verwendet werden.

K11-100 HEAD PARAMETER TABLE

Kartenplattenmodell	K11-100 selbstzentrierendes Spannfutter mit drei Klauen
Clip-Enge-Bereich	2 bis 80 mm
Engen Bereich halten	30-90 mm
Genauigkeit der Verwahrung	0,05 mm
Spitzenhöhe	65 mm
Hoheit	117 MM
Den Motor antreiben	57 Schrittmotor, 2-phasig 3A 57 Schrittmotor; 57 * 57 * 76MM; 4 Leitungen
Übersetzungsverhältnis	6:1; (Riemenverzögerungsmodus)

LIST OF ACCESSORIES

Sequenznummer	Zubehörname	Anzahl der Packstücke
1	Teilkopf (mit Spannfutter)	1
2	Drehen Sie den Fingerhut, MT2	1
3	Numerisches Steuerkabel	1
4	Spannfuttergriff	1
5	Kartenplatte Anti-Krallen	3
6	Reitstock	1

Hersteller: Shanghai muxinmuyeyouxiangongsi

Adresse: Shuangchenglu 803nong11hao1602A-1609shi, baoshanqu, Shanghai 200000 CN.

Nach AUS importiert: SIHAO PTY LTD, 1 ROKEVA STREET EASTWOOD NSW 2122 Australien

Importiert in die USA: Sanven Technology Ltd., Suite 250, 9166 Anaheim Place, Rancho Cucamonga, CA 91730

EC	REP
-----------	------------

E-CrossStu GmbH
Mainzer Landstr.69, 60329 Frankfurt am Main.

UK	REP
-----------	------------

YH CONSULTING LIMITED.
C/O YH Consulting Limited Office 147, Centurion House,
London Road, Staines-upon-Thames, Surrey, TW18 4AX

VEVOR[®]

TOUGH TOOLS, HALF PRICE

Technisch Support und E-Garantie-Zertifikat

www.vevor.com/support

VEVOR[®]

TOUGH TOOLS, HALF PRICE

Tecnico Supporto e certificato di garanzia elettronica

www.vevor.com/support

TESTA DI DIVISIONE

MODELLO: BS4-KP100-57

We continue to be committed to provide you tools with competitive price.

"Save Half", "Half Price" or any other similar expressions used by us only represents an estimate of savings you might benefit from buying certain tools with us compared to the major top brands and does not necessarily mean to cover all categories of tools offered by us. You are kindly reminded to verify carefully when you are placing an order with us if you are actually saving half in comparison with the top major brands.

VEVOR®

TOUGH TOOLS, HALF PRICE

DIVIDING HEAD

MODELLO: BS4-KP100-57



NEED HELP? CONTACT US!

Have product questions? Need technical support? Please feel free to contact us:

Technical Support and E-Warranty Certificate
www.vevor.com/support

This is the original instruction, please read all manual instructions carefully before operating. VEVOR reserves a clear interpretation of our user manual. The appearance of the product shall be subject to the product you received. Please forgive us that we won't inform you again if there are any technology or software updates on our product.



Attenzione: per ridurre il rischio di lesioni, l'utente deve leggere attentamente il manuale di istruzioni.

MAINTENANCE INSTRUCTIONS

1. Per garantire che il mandrino della macchina mantenga una buona precisione anche dopo un lungo periodo di utilizzo, la lubrificazione è molto importante.
2. Dopo ogni turno, è necessario applicare grasso al bisolfuro di molibdeno (di colore nero), versando il grasso nelle ganasce del mandrino fino a quando non trabocca dalla superficie della ganasca o dal foro interno del mandrino. Tuttavia, se il mandrino ruota molto o contiene una grande quantità di acqua, quando si utilizza olio da taglio per la lavorazione è necessaria una maggiore lubrificazione, che deve essere determinata in base alle diverse situazioni.
3. Assicurarsi di utilizzare una pistola ad aria compressa o strumenti simili per pulire il corpo del mandrino e la superficie di scorrimento una volta completata l'operazione.
4. Rimuovere il mandrino almeno ogni 6 mesi per lo smontaggio e la pulizia e mantenere la superficie di scorrimento delle ganasce pulita e lubrificata in modo da prolungare la durata del mandrino. Tuttavia, se la ghisa da taglio viene pulita a fondo almeno una o più volte ogni 2 mesi, controllare le parti per crepe e usura e sostituirle immediatamente con parti nuove. Dopo aver completato l'ispezione, deve essere completamente oliato prima del montaggio.
5. L'uso di olio da taglio con effetto antiruggine può prevenire la ruggine all'interno del mandrino perché la ruggine del mandrino ridurrà la forza di serraggio e il pezzo in lavorazione non potrà essere serrato.

INSTRUCTIONS

4. Innanzitutto, è necessario confermare se il pezzo da lavorare necessita di un artiglio positivo o di un artiglio inverso. L'artiglio positivo può

trattenere un pezzo solido con un diametro di 48 mm e un tubo cavo da 100 mm, e l'artiglio inverso può contenere un pezzo con un diametro di 112 mm. I passaggi di sostituzione sono i seguenti:

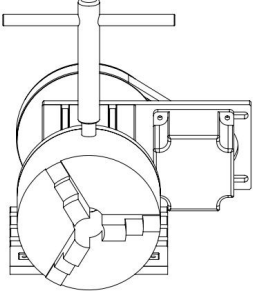
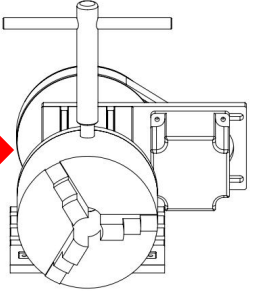
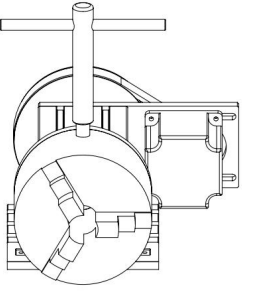
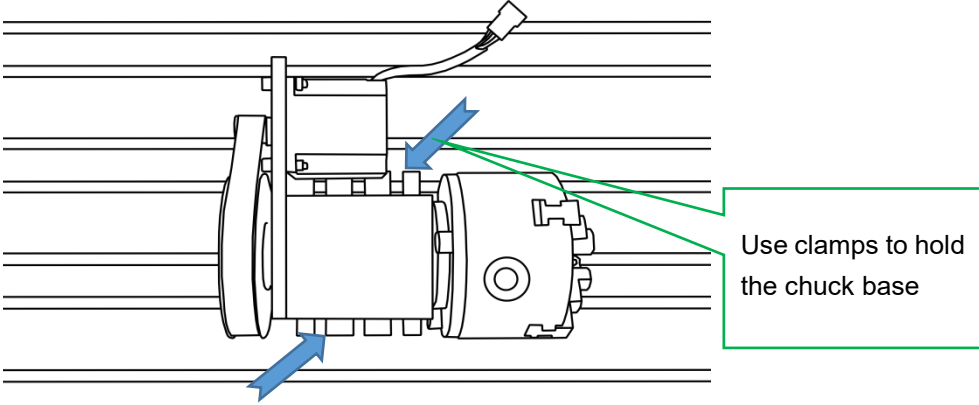
<p>Inserire la chiave del mandrino nel mandrino</p>	<p>Ruotare la chiave del mandrino in senso antiorario per estrarre le ganasce anteriore e posteriore</p>	<p>Ruotare la chiave del mandrino in senso orario per installare le ganasce anteriore e posteriore</p>
		
<p>2. Fissare il mandrino al tavolo di lavorazione e bloccare il pezzo da lavorare.</p> 		
<p>3. Inserire e bloccare rispettivamente entrambe le estremità del cavo.</p>		

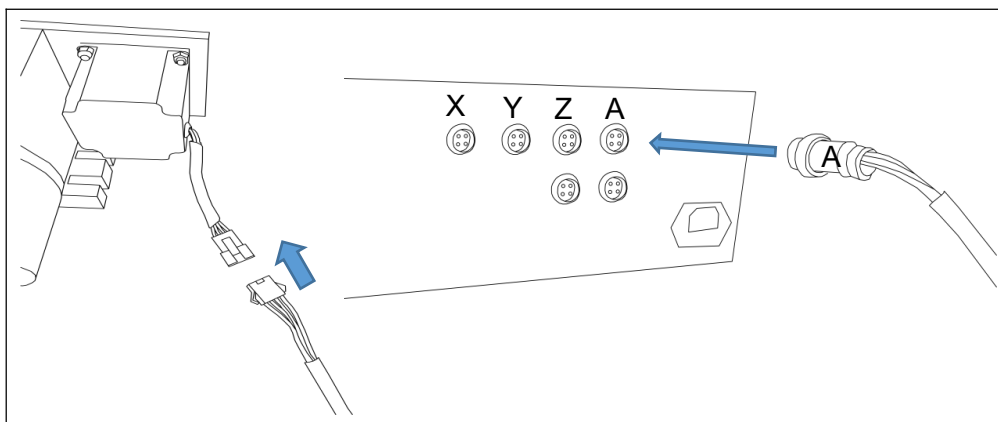

4. Quando il lavoro di cui sopra è pronto, puoi iniziare l'elaborazione. Le viti negli accessori sono viti di ricambio e non devono essere utilizzate a meno che non ci siano circostanze speciali.

K11-100 HEAD PARAMETER TABLE

Modello di piastra di carta	Mandrino autocentrante a tre griffe K11-100
Clip a distanza ravvicinata	2-80mm
Mantenere una distanza ristretta	30-90mm
Precisione della custodia	0,05 mm
altezza del centro	65mm
altezza	117MM
Azionare il motore	Motore passo-passo 57, motore passo-passo bifase 3A 57; 57 * 57 * 76MM; 4 cavi
rapporto di trasmissione	6:1; (Modalità di decelerazione della cinghia)

LIST OF ACCESSORIES

numero di sequenza	Nome degli accessori	numero di pacchetti
1	Testa divisoria (con mandrino)	1
2	Ruotare il ditale, MT2	1
3	Cavo di controllo numerico	1
4	Maniglia del mandrino	1
5	Piastra di carta anti-artiglio	3
6	Contropunta	1

Produttore: Shanghaimuxinmuyeyouxiangongsi

Indirizzo: Shuangchenglu 803nong11hao1602A-1609shi, baoshanqu, shanghai 200000 CN.

Importato in AUS: SIHAO PTY LTD, 1 ROKEVA STREETEASTWOOD NSW 2122 Australia

Importato negli USA: Sanven Technology Ltd., Suite 250, 9166 Anaheim Place, Rancho Cucamonga, CA 91730

EC	REP
-----------	------------

E-CrossStu GmbH
Mainzer Landstr.69, 60329 Frankfurt am Main.

UK	REP
-----------	------------

YH CONSULTING LIMITED.
C/O YH Consulting Limited Office 147, Centurion House,
London Road, Staines-upon-Thames, Surrey, TW18 4AX

VEVOR[®]

TOUGH TOOLS, HALF PRICE

Tecnico Supporto e certificato di garanzia elettronica

www.vevor.com/support

VEVOR[®]

TOUGH TOOLS, HALF PRICE

Técnico Certificado de soporte y garantía electrónica

www.vevor.com/support

CABEZA DIVISORIA

MODELO: BS4-KP100-57

We continue to be committed to provide you tools with competitive price.

"Save Half", "Half Price" or any other similar expressions used by us only represents an estimate of savings you might benefit from buying certain tools with us compared to the major top brands and does not necessarily mean to cover all categories of tools offered by us. You are kindly reminded to verify carefully when you are placing an order with us if you are actually saving half in comparison with the top major brands.

VEVOR®

TOUGH TOOLS, HALF PRICE

DIVIDING HEAD

MODELO: BS4-KP100-57



NEED HELP? CONTACT US!

Have product questions? Need technical support? Please feel free to contact us:

Technical Support and E-Warranty Certificate
www.vevor.com/support

This is the original instruction, please read all manual instructions carefully before operating. VEVOR reserves a clear interpretation of our user manual. The appearance of the product shall be subject to the product you received. Please forgive us that we won't inform you again if there are any technology or software updates on our product.



Advertencia: Para reducir el riesgo de lesiones, el usuario debe leer atentamente el manual de instrucciones.

MAINTENANCE INSTRUCTIONS

1. Para garantizar que el mandril de la máquina mantenga una buena precisión después de un uso prolongado, la lubricación es muy importante.
2. Se debe aplicar grasa de disulfuro de molibdeno (de color negro) después de cada turno, y la grasa se vierte en las mordazas del mandril hasta que la grasa se desborde de la superficie de la mordaza o el orificio interior del mandril, pero si el mandril gira mucho o tiene una gran cantidad de agua Cuando se usa aceite de corte para el procesamiento, necesita más lubricación, que debe determinarse de acuerdo con diferentes situaciones.
3. Asegúrese de utilizar una pistola de aire o herramientas similares para limpiar el cuerpo del mandril y la superficie deslizante una vez finalizada la operación.
4. Retire el mandril al menos cada 6 meses para desmontarlo y limpiarlo, y mantenga la superficie deslizante de las mordazas limpia y lubricada para prolongar la vida útil del mandril. Sin embargo, si la fundición de hierro de corte se limpia a fondo al menos una o varias veces cada 2 meses, verifique las piezas para ver si tienen grietas o desgaste y reemplácelas por otras nuevas de inmediato. Una vez completada la inspección, debe engrasarse completamente antes del montaje.
5. El uso de aceite de corte con efecto antioxidante puede evitar la oxidación dentro del mandril porque la oxidación del mandril reducirá la fuerza de sujeción y la pieza de trabajo no se podrá sujetar.

INSTRUCTIONS

5. En primer lugar, es necesario confirmar si la pieza a procesar necesita una garra positiva o una garra inversa. La garra positiva puede sujetar una pieza sólida con un diámetro de 48 mm y un tubo hueco de 100 mm, y la

garra inversa puede sujetar una pieza de trabajo con un diámetro de 112 mm. Los pasos de reemplazo son los siguientes:

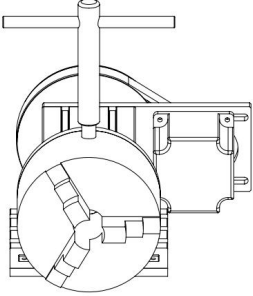
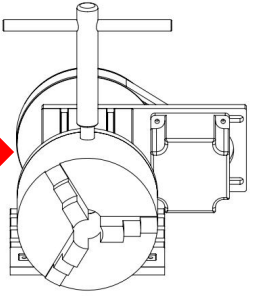
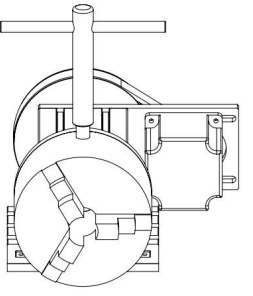
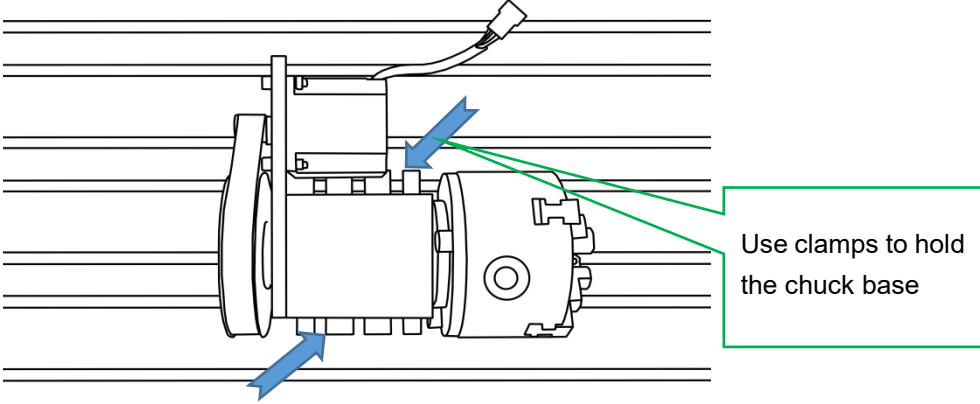
<p>Inserte la llave del portabrocas en el portabrocas.</p>	<p>Gire la llave del portabrocas en sentido antihorario para sacar las mordazas delanteras y traseras.</p>	<p>Gire la llave del portabrocas en el sentido de las agujas del reloj para instalar las mordazas delanteras y traseras.</p>
		
<p>2. Fije el mandril a la mesa de procesamiento y sujete la pieza de trabajo a procesar.</p>		
		
<p>3. Inserte y bloquee ambos extremos del cable respectivamente.</p>		

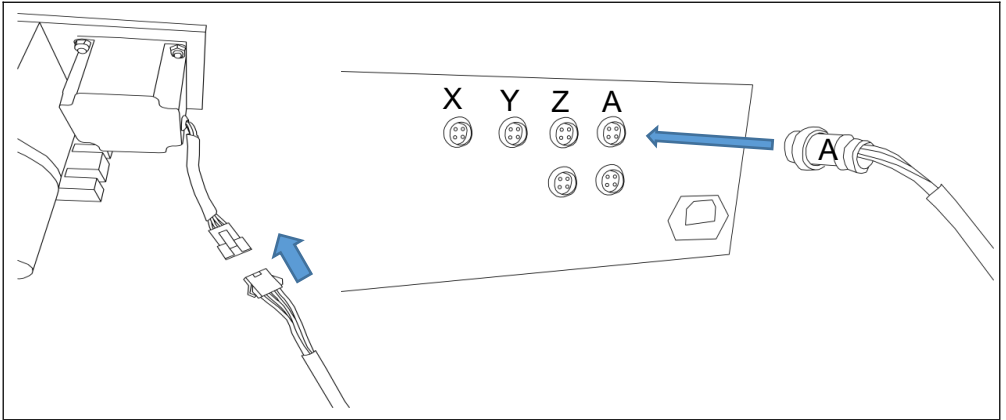

4. Cuando el trabajo anterior esté listo, puede comenzar a procesarlo. Los tornillos incluidos en los accesorios son tornillos de repuesto y no es necesario utilizarlos a menos que se den circunstancias especiales.

K11-100 HEAD PARAMETER TABLE

Modelo de placa de tarjeta	Mandril autocentrante de tres garras K11-100
Clip de rango estrecho	2-80 mm
Mantenga el rango ajustado	30-90 mm
Precisión de la custodia	0,05 mm
altura central	65 mm
Alteza	117MM
Conducir el motor	Motor paso a paso 57, motor paso a paso 57 de 2 fases y 3 A; 57 * 57 * 76 MM; 4 cables
relación de transmisión	6:1; (Modo de desaceleración de la correa)

LIST OF ACCESSORIES

Número de secuencia	Nombre del accesorio	Número de paquetes
1	Cabezal divisor (con mandril)	1
2	Gire el dedal, MT2	1
3	Cable de control numérico	1
4	mango del portabrocas	1
5	Placa de tarjeta anti-garra	3
6	Contrapunto	1

Fabricante: Shanghaimuxinmuyeyouxiangongsi

Dirección: Shuangchenglu 803nong11hao1602A-1609shi, baoshanqu, shanghai 200000 CN.

Importado a AUS: SIHAO PTY LTD, 1 ROKEVA STREETEASTWOOD NSW 2122 Australia

Importado a EE. UU.: Sanven Technology Ltd., Suite 250, 9166 Anaheim Place, Rancho Cucamonga, CA 91730

EC	REP
-----------	------------

E-CrossStu GmbH
Mainzer Landstr.69, 60329 Frankfurt am Main.

UK	REP
-----------	------------

YH CONSULTING LIMITED.
C/O YH Consulting Limited Office 147, Centurion House,
London Road, Staines-upon-Thames, Surrey, TW18 4AX

VEVOR[®]

TOUGH TOOLS, HALF PRICE

Técnico Certificado de soporte y garantía electrónica

www.vevor.com/support

VEVOR[®]

TOUGH TOOLS, HALF PRICE

Techniczny Wsparcie i certyfikat e-gwarancji

www.vevor.com/support

GŁOWICA DZIELĄCA

MODELE: BS4-KP100-57

We continue to be committed to provide you tools with competitive price.

"Save Half", "Half Price" or any other similar expressions used by us only represents an estimate of savings you might benefit from buying certain tools with us compared to the major top brands and does not necessarily mean to cover all categories of tools offered by us. You are kindly reminded to verify carefully when you are placing an order with us if you are actually saving half in comparison with the top major brands.

VEVOR®

TOUGH TOOLS, HALF PRICE

DIVIDING HEAD

MODELE: BS4-KP100-57



NEED HELP? CONTACT US!

Have product questions? Need technical support? Please feel free to contact us:

Technical Support and E-Warranty Certificate
www.vevor.com/support

This is the original instruction, please read all manual instructions carefully before operating. VEVOR reserves a clear interpretation of our user manual. The appearance of the product shall be subject to the product you received. Please forgive us that we won't inform you again if there are any technology or software updates on our product.



Ostrzeżenie: Aby zminimalizować ryzyko obrażeń, użytkownik powinien uważnie przeczytać instrukcję obsługi.

MAINTENANCE INSTRUCTIONS

1. Aby mieć pewność, że uchwyt maszynowy zachowa dobrą dokładność po długim okresie użytkowania, bardzo ważne jest smarowanie.
2. Smar dwusiarczkowy molibdenu (czarny) należy nakładać po każdej zmianie, wlewając smar do szczęk uchwytu, aż zacznie się wylewać z powierzchni szczęk lub wewnętrznego otworu uchwytu, ale jeśli uchwyt obraca się mocno lub zawiera dużą ilość wody, podczas obróbki przy użyciu oleju chłodząco-smarującego wymagane jest więcej smarowania, co należy ustalić w zależności od różnych sytuacji.

Po zakończeniu operacji należy koniecznie wyczyścić korpus uchwytu i powierzchnię ślizgową za pomocą pistoletu pneumatycznego lub podobnego narzędzia .

4. Wyjmij uchwyt co najmniej raz na 6 miesięcy w celu demontażu i czyszczenia, a także utrzymuj powierzchnię ślizgową szczęk w czystości i nasmarowaną, aby wydłużyć żywotność uchwytu. Jeśli jednak żeliwo tnące jest dokładnie czyszczone co najmniej raz lub kilka razy co 2 miesiące, sprawdź części pod kątem pęknięć i zużycia i natychmiast

wymień je na nowe. Po zakończeniu kontroli należy je całkowicie naoliwić przed montażem.

5. Zastosowanie oleju chłodząco-smarującego o działaniu antykorozyjnym może zapobiec powstawaniu rdzy wewnątrz uchwytu, ponieważ rdza w uchwycie zmniejszy siłę mocowania, a obrabiany przedmiot nie będzie mógł zostać zamocowany.

INSTRUCTIONS

6. Przede wszystkim należy potwierdzić, czy obrabiany przedmiot

wymaga pozytywnego czy odwrotnego pazura. Pozytywny pazur może utrzymać pełny przedmiot obrabiany o średnicy 48 mm i rurę pustą o średnicy 100 mm, a pazur odwrotny może utrzymać przedmiot obrabiany o średnicy 112 mm. Kroki wymiany są następujące.:

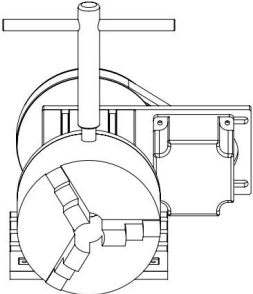
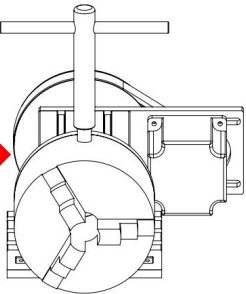
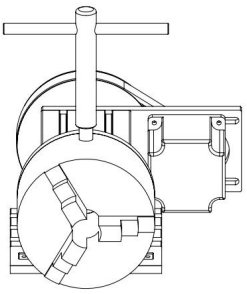
<p>Włóż klucz do uchwytu</p>	<p>Obróć klucz zaciskowy przeciwnie do ruchu wskazówek zegara, aby wyjąć szczękę przednie i tylne</p>	<p>Obróć klucz zaciskowy zgodnie z ruchem wskazówek zegara, aby zamontować szczękę przednie i tylne</p>
		

2. Zamocuj uchwyt do stołu obróbczego i zamocuj obrabiany przedmiot.

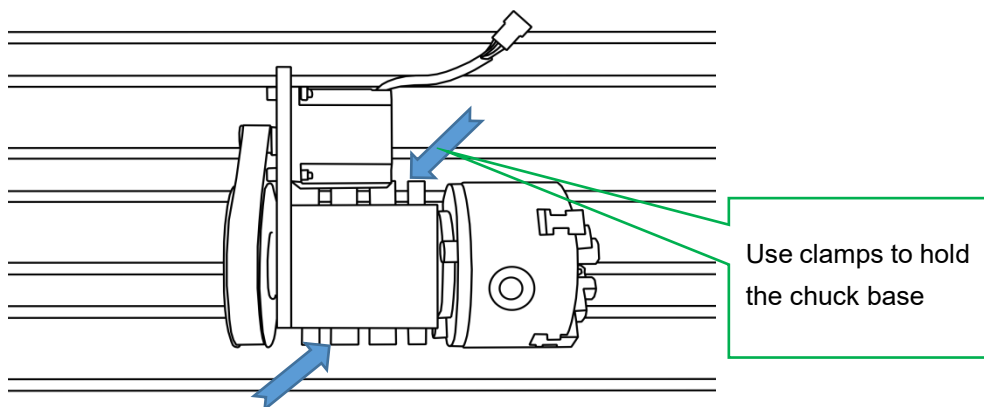

3. Włóż i zablokuj oba końce kabla.

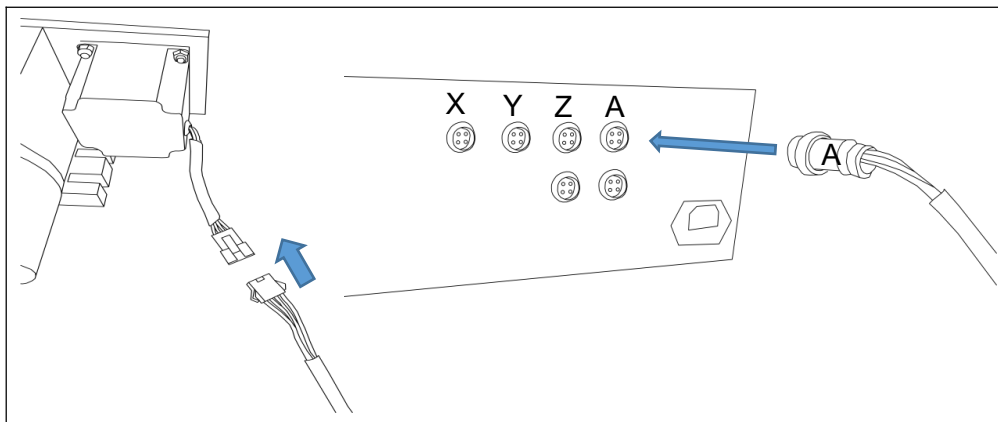

4. Gdy powyższe prace są gotowe, możesz rozpocząć przetwarzanie. Śruby w akcesoriach są śrubami zapasowymi i nie trzeba ich używać, chyba że zaistnieją szczególne okoliczności.

K11-100 HEAD PARAMETER TABLE

Model płytki kartowej	Uchwyt samocentrujący trzy-pazurowy K11-100
Przytnij ciasny zakres	2-80mm
Trzymaj mocno zasięg	30-90 mm
Precyzja opieki	0,05 mm
wysokość środka	65 mm
wygórowanie	117MM
Napęd silnika	Silnik krokowy 57, 2-fazowy 3A Silnik krokowy 57; 57 * 57 * 76MM; 4 przewody
przełożenie	6:1; (Tryb zwalniania pasa)

LIST OF ACCESSORIES

numer sekwencyjny	Nazwa akcesoriów	liczba paczek
1	Głowica dzieląca (z uchwytem)	1
2	Obrót nasadkę, MT2	1
3	Przewód sterowania numerycznego	1
4	uchwyt uchwyty	1
5	Płytki z kartą anty-drapanie	3
6	Konik	1

Producent: Shanghaimuxinmuyeyouxiangongsi

Adres: Shuangchenglu 803nong11hao1602A-1609shi, baoshanqu, szanghaj 200000 CN.

Importowane do AUS: SIHAO PTY LTD, 1 ROKEVA STREETEASTWOOD NSW 2122 Australia

Importowane do USA: Sanven Technology Ltd., Suite 250, 9166 Anaheim Place, Rancho Cucamonga, CA 91730

EC	REP
-----------	------------

E-CrossStu GmbH
Mainzer Landstr.69, 60329 Frankfurt am Main.

UK	REP
-----------	------------

YH CONSULTING LIMITED.
C/O YH Consulting Limited Office 147, Centurion House,
London Road, Staines-upon-Thames, Surrey, TW18 4AX

VEVOR[®]

TOUGH TOOLS, HALF PRICE

Techniczny Wsparcie i certyfikat e-gwarancji

www.vevor.com/support

VEVOR[®]

TOUGH TOOLS, HALF PRICE

Technisch Ondersteuning en E-garantiecertificaat

www.vevor.com/support

VERDEELKOP

MODEL: BS4-KP100-57

We continue to be committed to provide you tools with competitive price.

"Save Half", "Half Price" or any other similar expressions used by us only represents an estimate of savings you might benefit from buying certain tools with us compared to the major top brands and does not necessarily mean to cover all categories of tools offered by us. You are kindly reminded to verify carefully when you are placing an order with us if you are actually saving half in comparison with the top major brands.

VEVOR®

TOUGH TOOLS, HALF PRICE

DIVIDING HEAD

MODEL: BS4-KP100-57



NEED HELP? CONTACT US!

Have product questions? Need technical support? Please feel free to contact us:

Technical Support and E-Warranty Certificate
www.vevor.com/support

This is the original instruction, please read all manual instructions carefully before operating. VEVOR reserves a clear interpretation of our user manual. The appearance of the product shall be subject to the product you received. Please forgive us that we won't inform you again if there are any technology or software updates on our product.



Waarschuwing: om het risico op letsel te verkleinen, moet de gebruiker de gebruiksaanwijzing zorgvuldig lezen.

MAINTENANCE INSTRUCTIONS

1. Om ervoor te zorgen dat de klauwplaat van de machine ook na langdurig gebruik nog steeds nauwkeurig is, is smering erg belangrijk.
2. Na elke dienst moet molybdeendisulfidevet (zwart van kleur) worden aangebracht en het vet wordt in de kaken van de klauwplaat gegoten totdat het vet over het klauwoppervlak of het binnenste gat van de klauwplaat stroomt. Als de klauwplaat echter sterk draait of veel water bevat, is er meer smering nodig wanneer snijolie wordt gebruikt voor verwerking. Dit moet worden bepaald op basis van verschillende situaties.
3. Zorg ervoor dat u een luchtpistool of een soortgelijk hulpmiddel gebruikt om de klauwplaat en het glijvlak schoon te maken wanneer de bewerking is voltooid.
4. Verwijder de klauwplaat ten minste elke 6 maanden voor demontage en reiniging, en houd het glijvlak van de kaken schoon en gesmeerd zodat de levensduur van de klauwplaat wordt verlengd. Als het snijgietijzer echter ten minste één of meerdere keren per 2 maanden grondig wordt gereinigd, controleer dan de onderdelen op scheuren en slijtage en vervang ze onmiddellijk door nieuwe. Nadat de inspectie is voltooid, moet deze volledig worden geolied voordat deze wordt gemonteerd.
5. Het gebruik van snijolie met een roestwerende werking kan roestvorming in de klauwplaat voorkomen, omdat roest van de klauwplaat de klemkracht vermindert en het werkstuk niet kan worden vastgeklemd.

INSTRUCTIONS

7. Allereerst is het noodzakelijk om te bevestigen of het te bewerken werkstuk een positieve klauw of een omgekeerde klauw nodig heeft. De positieve klauw kan een massief werkstuk met een diameter van 48 vasthouden mm en een holle pijp van 100 mm, en de omgekeerde klauw

kan een werkstuk met een diameter van 112 mm vasthouden. De vervangingsstappen zijn als volgt:

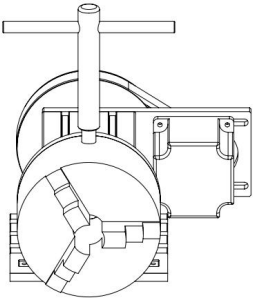
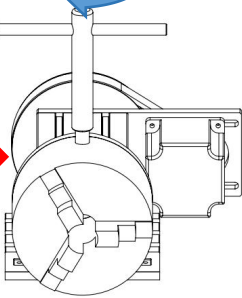
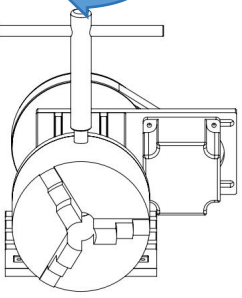
Steek de boorkopsleutel in de boorkop	Draai de boorkopsleutel tegen de klok in om de voor- en achterbekken eruit te halen	Draai de boorkopsleutel met de klok mee om de voor- en achterbekken te installeren
		

2. Bevestig de klauwplaat aan de bewerkingstafel en klem het te bewerken werkstuk vast.

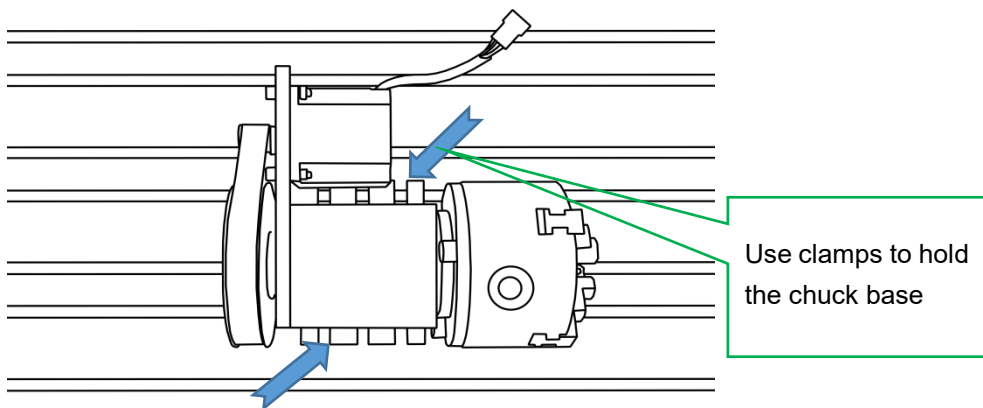

3. Plaats en vergrendel beide uiteinden van de kabel.

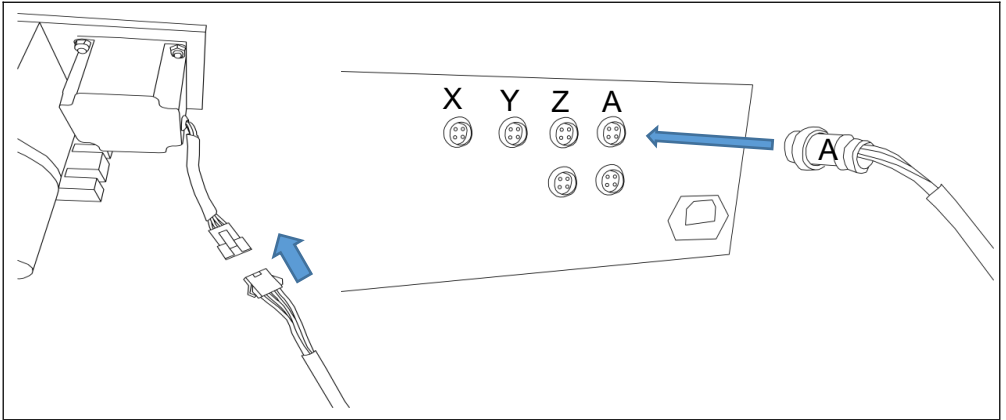

4. Wanneer het bovenstaande werk klaar is, kunt u beginnen met de verwerking. De schroeven in de accessoires zijn reserveschroeven en hoeven niet te worden gebruikt, tenzij er speciale omstandigheden zijn.

K11-100 HEAD PARAMETER TABLE

Kaartplaatmodel	K11-100 drieklauw zelfcentrerende klauwplaat
Clip krap bereik	2-80mm
Houd een strak bereik	30-90mm
Precisie van de bewaring	0,05 mm
middenhoogte	65mm
hoogheid	117MM
De motor aandrijven	57 stappenmotor, 2-fase 3A 57 stappenmotor; 57 * 57 * 76MM; 4-aderig
overbrengingsverhouding	6:1; (Bandvertragsmodus)

LIST OF ACCESSORIES

volgnummer	Naam accessoires	aantal pakketten
1	Verdeelkop (met klauw)	1
2	Draai de vingerhoed, MT2	1
3	Numerieke besturingskabel	1
4	klauw handvat	1
5	Kaartplaat anti-klauw	3
6	Losse kop	1

Fabrikant: Shanghaimuxinmuyeyouxiangongsi

Adres: Shuangchenglu 803nong11hao1602A-1609shi, baoshanqu, shanghai 200000 CN.

Geïmporteerd naar AUS: SIHAO PTY LTD, 1 ROKEVA

STREETEASTWOOD NSW 2122 Australië

Geïmporteerd naar de VS: Sanven Technology Ltd., Suite 250, 9166

Anaheim Place, Rancho Cucamonga, CA 91730

EC	REP
-----------	------------

E-CrossStu GmbH

Mainzer Landstr.69, 60329 Frankfurt am Main.

UK	REP
-----------	------------

YH CONSULTING LIMITED.

C/O YH Consulting Limited Office 147, Centurion House,
London Road, Staines-upon-Thames, Surrey, TW18 4AX

VEVOR[®]

TOUGH TOOLS, HALF PRICE

Technisch Ondersteuning en E-garantiecertificaat

www.vevor.com/support

VEVOR[®]

TOUGH TOOLS, HALF PRICE

Teknisk Support och e-garanticertifikat

www.vevor.com/support

DELANDE HUVUDET

MODELL: BS4-KP100-57

We continue to be committed to provide you tools with competitive price.

"Save Half", "Half Price" or any other similar expressions used by us only represents an estimate of savings you might benefit from buying certain tools with us compared to the major top brands and does not necessarily mean to cover all categories of tools offered by us. You are kindly reminded to verify carefully when you are placing an order with us if you are actually saving half in comparison with the top major brands.

VEVOR®

TOUGH TOOLS, HALF PRICE

DIVIDING HEAD

MODELL: BS4-KP100-57



NEED HELP? CONTACT US!

Have product questions? Need technical support? Please feel free to contact us:

Technical Support and E-Warranty Certificate
www.vevor.com/support

This is the original instruction, please read all manual instructions carefully before operating. VEVOR reserves a clear interpretation of our user manual. The appearance of the product shall be subject to the product you received. Please forgive us that we won't inform you again if there are any technology or software updates on our product.



Varning - För att minska risken för skada måste användaren läsa instruktionerna noggrant.

MAINTENANCE INSTRUCTIONS

1. För att säkerställa att maskinchucken fortfarande har god noggrannhet efter att ha använts under lång tid är smörjning mycket viktig.
2. Molybdendisulfidfett (svart till färgen) måste appliceras efter varje skift, och fettets håll i chuckens käftar tills fettets rinner över käftytan eller det inre hålet i chucken, men om chucken är kraftigt roterat eller har en stor mängd vatten När skärolja används för bearbetning behöver den mer smörjning, vilket måste bestämmas efter olika situationer.
3. Se till att använda en luftpistol eller liknande verktyg för att rengöra chuckkroppen och glidytan när operationen är klar.
4. Ta bort chucken minst var 6:e månad för demontering och rengöring, och håll käftarnas glidyta ren och smord så att chuckens livslängd förlängs. Men om det skärande gjutjärnet rengörs noggrant minst en eller flera gånger varannan månad, kontrollera delarna med avseende på sprickor och slitage och byt ut dem omedelbart mot nya. Efter att inspektionen är klar måste den oljas helt innan montering.
5. Användning av skärolja med rostskyddseffekt kan förhindra rost inuti chucken eftersom rost på chucken minskar klämkraften och arbetsstycket kan inte spännas fast.

INSTRUCTIONS

8. Först och främst är det nödvändigt att bekräfta om arbetsstycket som ska bearbetas behöver en positiv klo eller en omvänd klo. Den positiva klon kan hålla ett fast arbetsstycke med en diameter på 48 mm och ett ihåligt rör på 100 mm, och den omvända klon kan hålla ett arbetsstycke med en diameter på 112 mm. Ersättningsstegen är följande.:

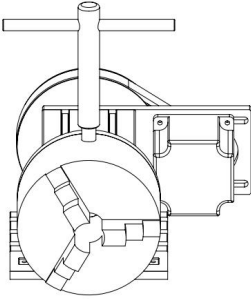
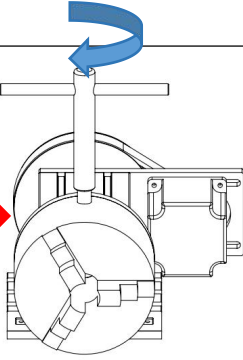
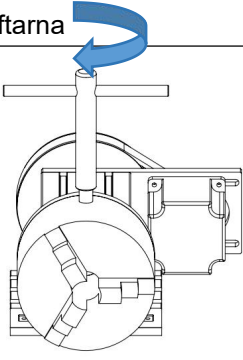
<p>Sätt in chucknyckeln i chucken</p>	<p>Vrid chucknyckeln moturs för att ta ut de främre och bakre käftarna</p>	<p>Vrid chucknyckeln medurs för att installera de främre och bakre käftarna</p>
		

2. Fäst chucken vid bearbetningsbordet och kläm fast arbetsstycket som ska bearbetas.

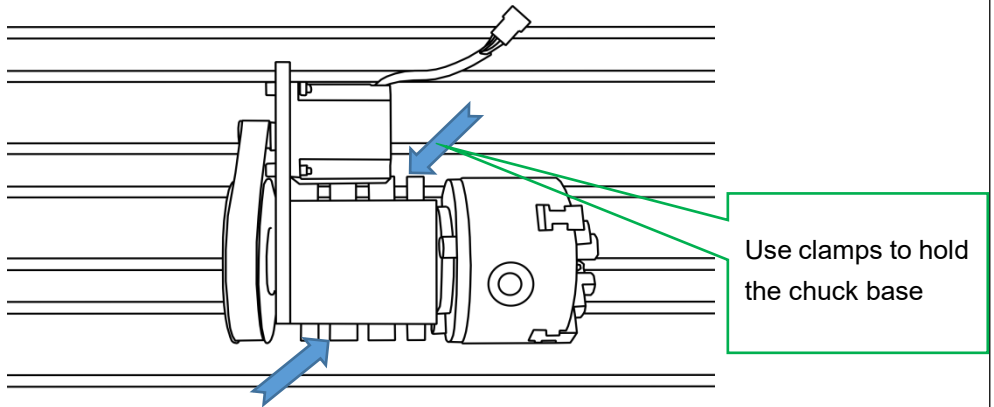

3. Sätt i och lås båda ändarna av kabeln.

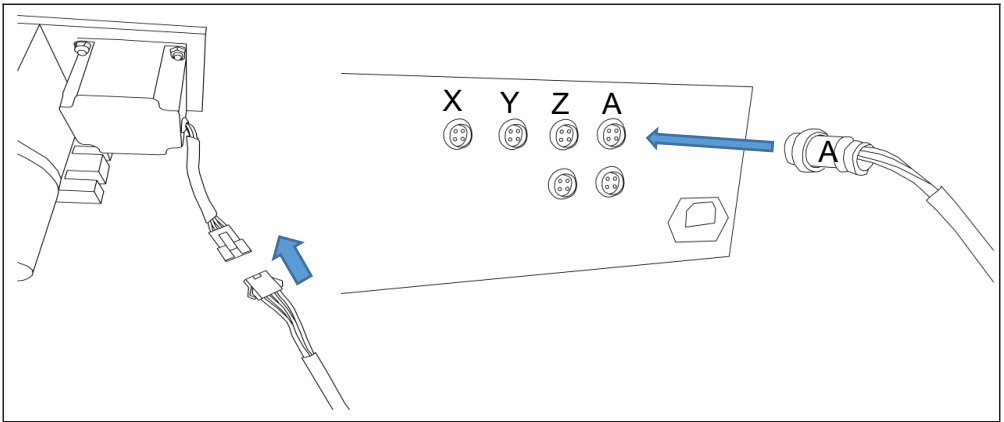

4. När ovanstående arbete är klart kan du börja bearbeta. Skruvarna i tillbehören är reservskruvar och behöver inte användas om det inte finns särskilda omständigheter.

K11-100 HEAD PARAMETER TABLE

Kortplatta modell	K11-100 treklos självcenterande chuck
Kläm tätt intervall	2-80 mm
Håll snäv räckvidd	30-90 mm
Förvaringsprecision	0,05 mm
mitthöjd	65 mm
höghet	117 MM
Kör motorn	57 stegmotor, 2-fas 3A 57 stegmotor; 57 * 57 * 76 MM; 4 bly
utväxlingsförhållande	6:1; (Bältets retardationsläge)

LIST OF ACCESSORIES

sekvensnummer	Namn på tillbehör	antal paket
1	Delningshuvud (med chuck)	1
2	Vrid fingerborgen, MT2	1
3	Numerisk styrkabel	1
4	chuckhandtag	1
5	Kartplatta anti-klo	3
6	Stjærtstock	1

Tillverkare: Shanghaimuxinmuyeyouxiangongsi

Address: Shuangchenglu 803nong11hao1602A-1609shi, baoshanqu, shanghai 200000 CN.

Importerad till AUS: SIHAO PTY LTD, 1 ROKEVA STREETEASTWOOD NSW 2122 Australien

Importerad till USA: Sanven Technology Ltd., Suite 250, 9166 Anaheim Place, Rancho Cucamonga, CA 91730

EC	REP
-----------	------------

E-CrossStu GmbH
Mainzer Landstr.69, 60329 Frankfurt am Main.

UK	REP
-----------	------------

YH CONSULTING LIMITED.
C/O YH Consulting Limited Office 147, Centurion House,
London Road, Staines-upon-Thames, Surrey, TW18 4AX

VEVOR[®]

TOUGH TOOLS, HALF PRICE

Teknisk Support och e-garanticertifikat

www.vevor.com/support