

VEVOR[®]

TOUGH TOOLS, HALF PRICE

Technical Support and E-Warranty Certificate www.vevor.com/support

MESH GARDEN CART TC2024 USER MANUAL

We continue to be committed to provide you tools with competitive price.

"Save Half", "Half Price" or any other similar expressions used by us only represents an estimate of savings you might benefit from buying certain tools with us compared to the major top brands and does not necessarily mean to cover all categories of tools offered by us. You are kindly reminded to verify carefully when you are placing an order with us if you are actually saving half in comparison with the top major brands.

TC2024



NEED HELP? CONTACT US!

Have product questions? Need technical support? Please feel free to contact us:

Technical Support and E-Warranty Certificate www.vevor.com/support

This is the original instruction. Please read all manual instructions carefully before operating. VEVOR reserves clear interpretation of our user manual. The appearance of the product shall be subject to the product you received. Please forgive us that we won't inform you again if there is any technology or software updates on our product.

SAFETY INSTRUCTIONS

WARNING:

1. Please check and confirm that the cart is intact and the tire pressure is normal before each use.
2. It is forbidden to carry people at any condition.
3. It is forbidden to load articles on uneven and hilly terrains.
4. Overload is strictly prohibited.
5. Don't move too fast when passing potholes areas

CAUTION: Carefully read instructions and procedures for safe operations.

MODEL AND PARAMETERS

Model	TC2024
Maximum Static Load	1400lbs
Tire Pressure	25-30psi
Frame Size	(1110±10) x (755±10) mm
Wheels Specification(in)	16*4.00-8 (Dia. * Width-Hub Size)

COMPONENTS

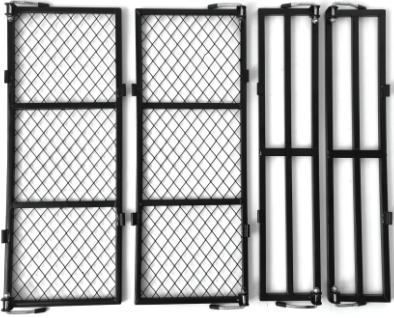

A. End sections(×2)



B. Side sections(×2)



C. Pneumatic wheels(×4)

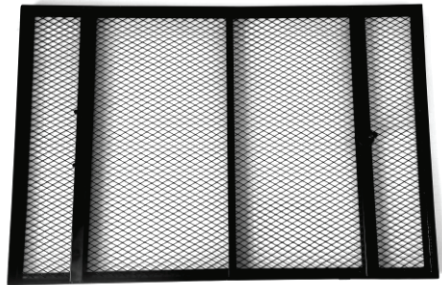

D. Base(×1)

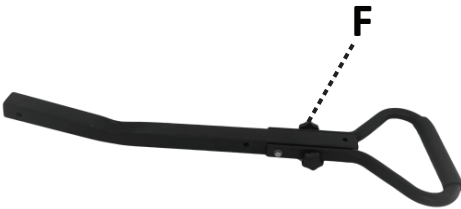

E. Handle(×1)



F. Five star screw and nut(×1)



G. Handle bracket(×1)



H. Front axle(×1)



I. Rear axle(×1)

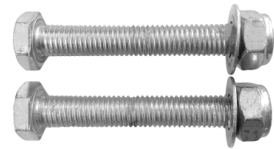

J. Bolts/Washers/Nuts(×2)

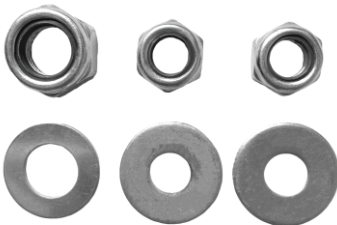

K. Large nylon nuts/washers(M12x2+M18×1)



L. Bolt nut/Washer(×1)



M. R-pins(×16)



O. Section link pieces(×8)



N. Split pins(×4)



P. Wheel washers(×4)



Q. Rubber mat(×1)

ASSEMBLY

Step 1: Fix the handle bracket(G) to the front axle(H), using the 2 of bolts/washers/ nuts(J).

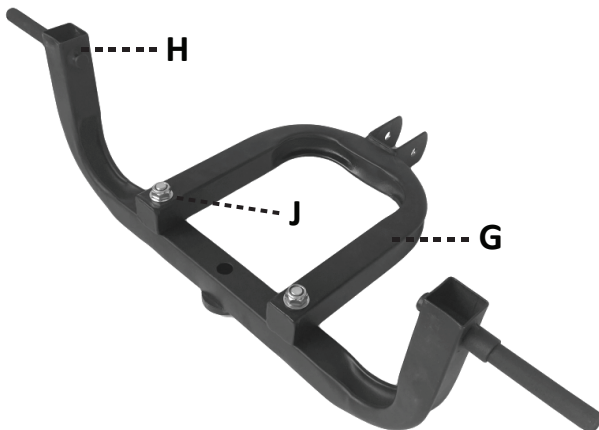

Step 2: Take the base(D) and turn it upside down, so that the protruding bolts are facing upwards.

Place both axles(H/I) on the bolts, followed by tight axles on the place, using the 2 large nylon nuts/washers(K) as shown.

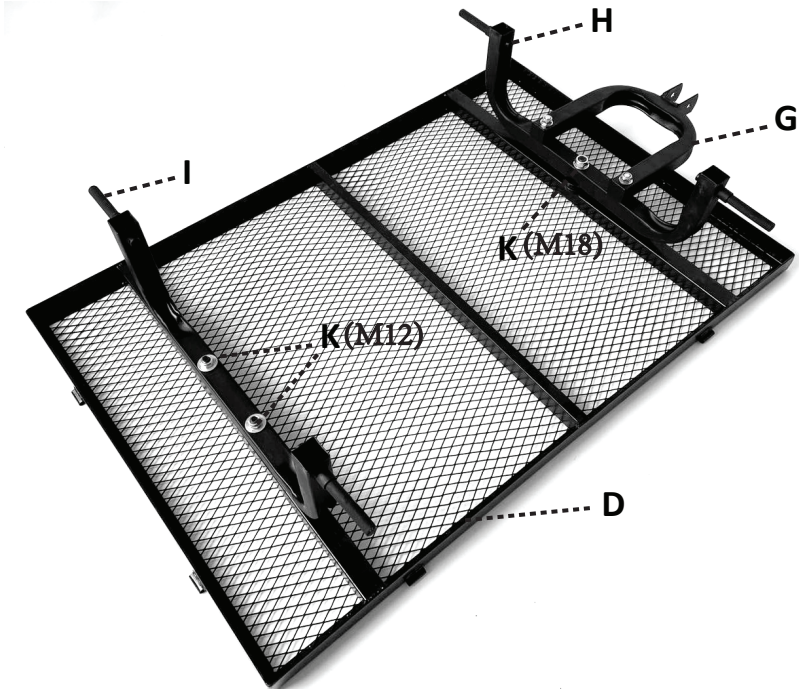

Step 3: Attach the 4 pneumatic wheels(C) to each end of the assembled base, followed by wheel washer(P).

Thread split pin(N) through each of the holes and bending to secure them into place.

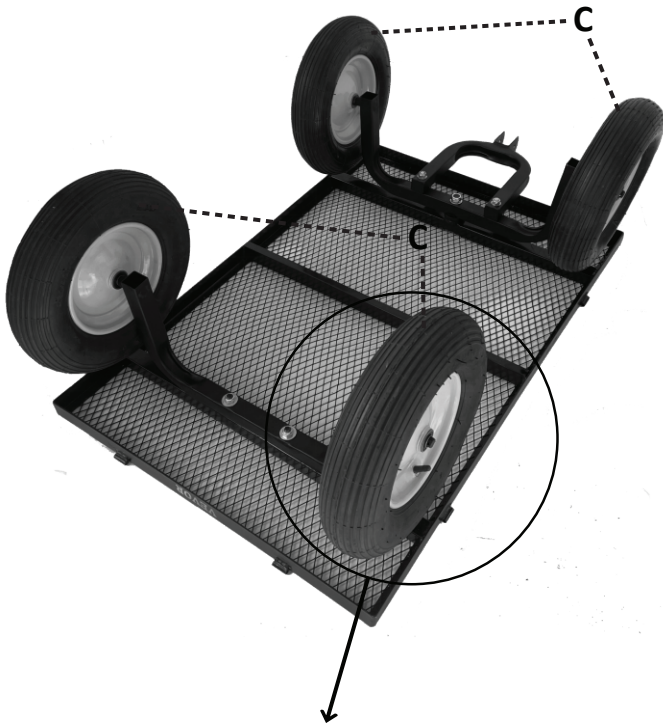

Step 4: Remove the bolt/washer/nut(L(f))from the plastic block(F).
Aligning up the handle(E) and the plastic block(L)(F) to the holes of the
handle bracket(G).

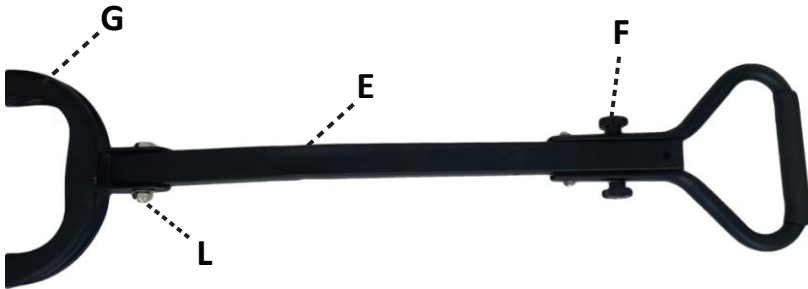
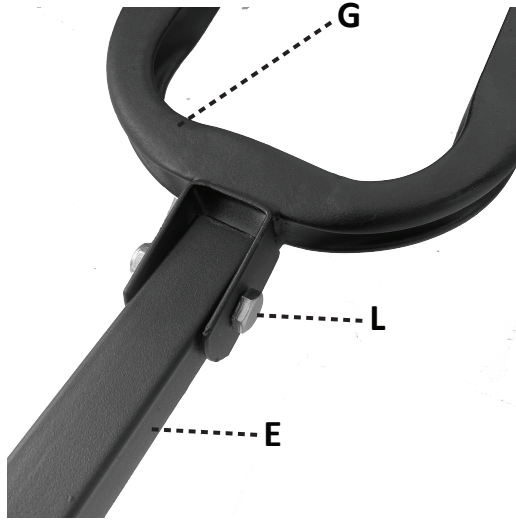

Step 5: Put the assembled cart onto its wheels, then take the side sections(B)and the end sections(A), securing them into place using the R-pins(M).

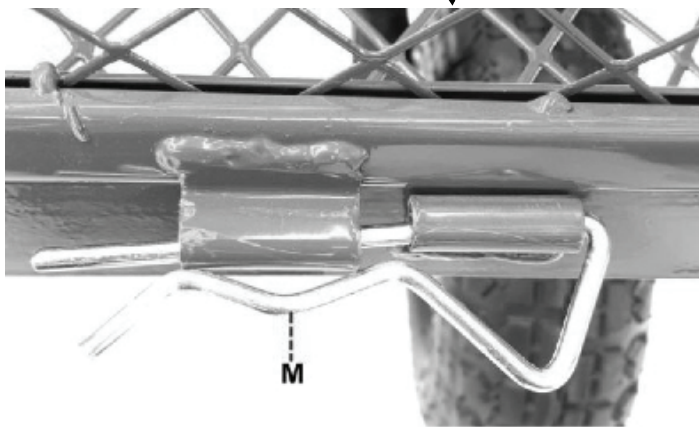
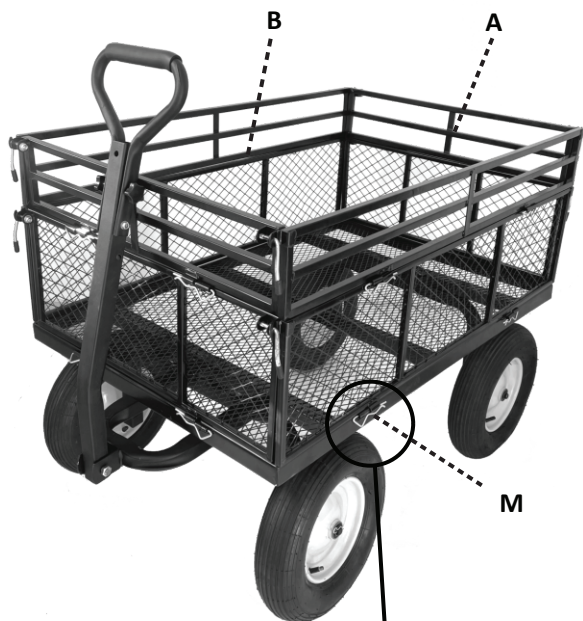

NOTE: Ensure the brackets are on the outside of the cart for keeping the sides and ends sitting flush.

NOTE: Lift the locking handles to align with the slots on the side panels. Lower the locking handles to secure.

Step 6: After releasing the trolley handle, it can also be used for traction and motor vehicle connection, only rotating the trolley handle upward and fix the handle on the upper hole with the five-star screen and nut.



Manufacturer: Shanghai muxin muyeyouxiangongsi

Address: Shuangchenglu 803nong11hao1602A-1609shi, baoshanqu, shanghai 200000 CN.

Imported to AUS: SIHAO PTY LTD. 1 ROKEVA STREET EASTWOOD NSW 2122 Australia

Imported to USA: Sanven Technology Ltd. Suite 250, 9166 Anaheim Place, Rancho Cucamonga, CA 91730



E-CrossStu GmbH
Mainzer Landstr.69, 60329 Frankfurt am Main.



YH CONSULTING LIMITED.
C/O YH Consulting Limited Office 147, Centurion House,
London Road, Staines-upon-Thames, Surrey, TW18 4AX

VEVOR[®]

TOUGH TOOLS, HALF PRICE

Technical Support and E-Warranty Certificate

www.vevor.com/support

VEVOR®

TOUGH TOOLS, HALF PRICE

Technical Support and E-Warranty Certificate www.vevor.com/support

WÓZEK OGRODOWY Z SIATKI

TC2024

INSTRUKCJA OBSŁUGI

Nadal staramy się oferować Państwu narzędzia w konkurencyjnych cenach.

„Oszczędź połowę”, „Połowa ceny” lub inne podobne wyrażenia używane przez nas stanowią jedynie szacunkowe oszczędności, jakie możesz uzyskać, kupując u nas określone narzędzia w porównaniu z głównymi markami i niekoniecznie oznaczają one objęcie wszystkich kategorii narzędzi oferowanych przez nas. Uprzejmie przypominamy, aby dokładnie sprawdzić, czy składając u nas zamówienie faktycznie oszczędzasz połowę w porównaniu z głównymi markami.

VEVOR®

WÓZEK OGRODOWY Z SIATKI

TC2024

INSTRUKCJA OBSŁUGI

TC2024



POTRZEBUJESZ POMOCY? SKONTAKTUJ SIĘ Z NAMI!

Have product questions? Need technical support? Please feel free Abby się z nami skontaktować:

Wsparcie techniczne i certyfikat gwarancji elektronicznej www.vevor.com/support

To jest oryginalna instrukcja. Przed użyciem przeczytaj uważnie wszystkie instrukcje. Stan produktu będzie zależał od produktu, który VEVOR reserves clear interpretation of our user manual. The appotrzymałeś. Przepraszamy, że nie poinformujemy Cię ponownie, jeśli pojawią się jakiegokolwiek aktualizacje technologii lub oprogramowania w naszym produkcie.

INSTRUKCJE BEZPIECZEŃSTWA

OSTRZEŻENIE:

1. Sprawdź i potwierdź, że wózek jest nienaruszony i ciśnienie w oponach jest prawidłowe. normalne przed każdym użyciem.
2. Zabrania się przewożenia osób w jakichkolwiek warunkach.
3. Zabrania się załadunku przedmiotów na nierównym i pagórkowatym terenie.
4. Przeciążanie jest surowo zabronione.
5. Nie poruszaj się zbyt szybko podczas pokonywania dziur w drogach.

UWAGA: Aby zapewnić bezpieczną obsługę, należy uważnie przeczytać instrukcje i procedury.

MODEL I PARAMETRY

Model	TC2024
Maksymalne obciążenie statyczne	1400 funtów
Ciśnienie w oponach	25-30 psi
Rozmiar ramki	(1110±10) x (755±10) mm
Specyfikacja kół (w calach)	16*4.00-8 Średnica * Szerokość-Rozmiar piasty

SKŁADNIKI



A. Sekcje końcowe (×2)



B. Sekcje boczne (×2)



C. Koła pneumatyczne (×4)

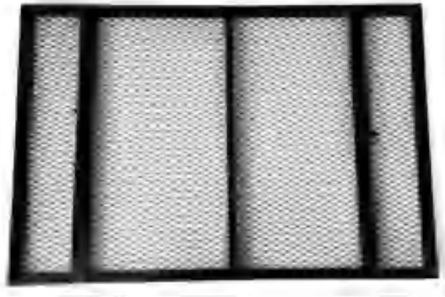

D. Podstawa (×1)

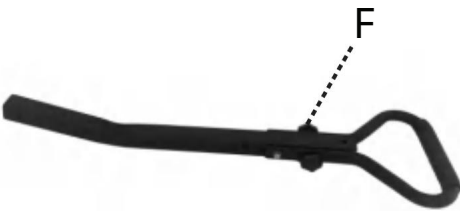

E. Uchwyt (×1)



F. Śruba pięcioramienna i nakrętka (x1)



G. Uchwyt uchwyty (×1)



H. Oś przednia (×1)



I. Oś tylna (×1)



J. Śruby/podkładki/nakrętki (×2)



K. Duże nakrętki/podkładki nylonowe (M12×2+M18×1)



L. Nakrętka/podkładka śruby (×1)



M. R-piny (×16)



O. Sekcja łączy elementy (×8)



N. Zawlecзки (×4)



P. Podkładki do kół (×4)



P. Mata gumowa (×1)

MONTAŻ

Krok 1: Przymocuj uchwyt (G) do przedniej osi (H) za pomocą 2 śrub/podkładek/nakrętek (J).

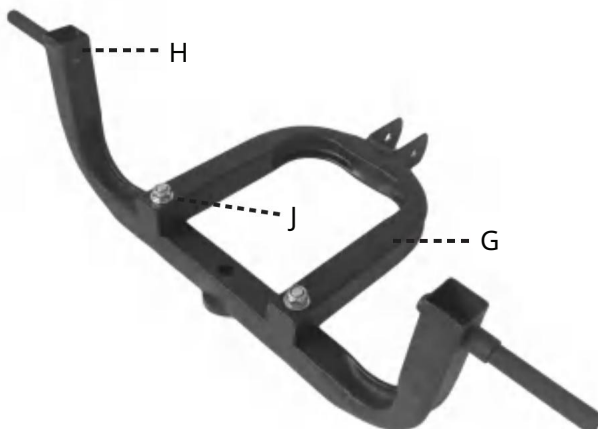

Krok 2: Weź podstawę (D) i odwróć ją do góry nogami, tak aby wystające śruby były skierowane ku górze.

K

Umieść obie osie (H/I) na śrubach, a następnie dokręć osie na miejscu, używając 2 dużych nakrętek/podkładek nylonowych (K), jak pokazano.

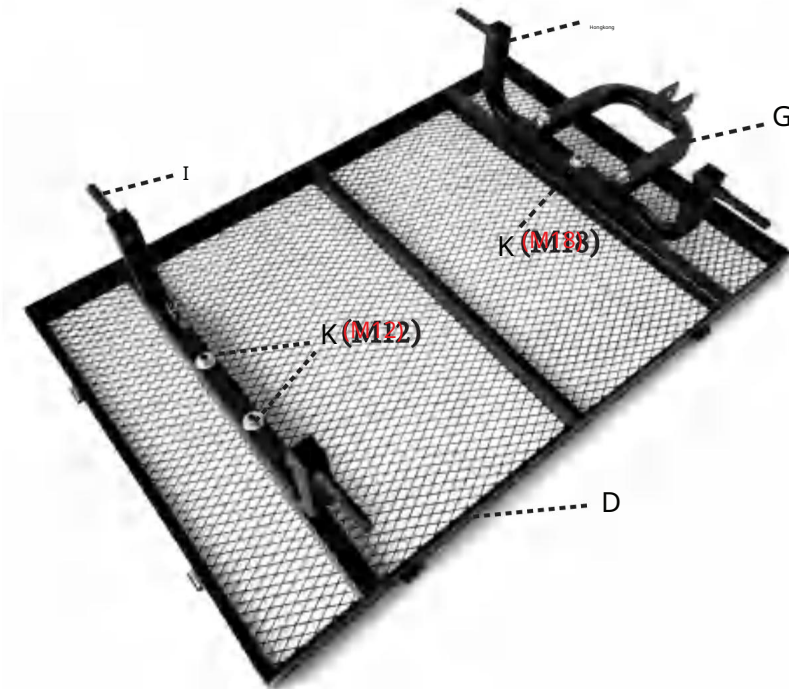

Krok 3: Zamontuj 4 koła pneumatyczne (C) do każdego końca zmontowanej podstawy, a następnie podkładkę do kół (P).

Przewlecż zawleczkę (N) przez każdy z otworów i zagnij ją, aby zamocować ją na miejscu.

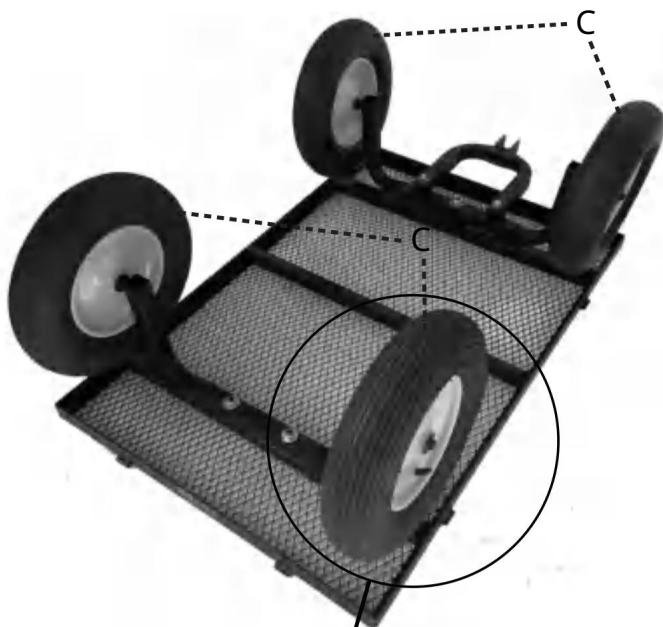

Krok 4: Zdejmij śrubę/podkładkę/nakrętkę (L(f)) z plastikowego bloku (F).
Wyrównanie uchwyty (E) i plastikowego bloku (L)(F) z otworami wspornika uchwyty (G).

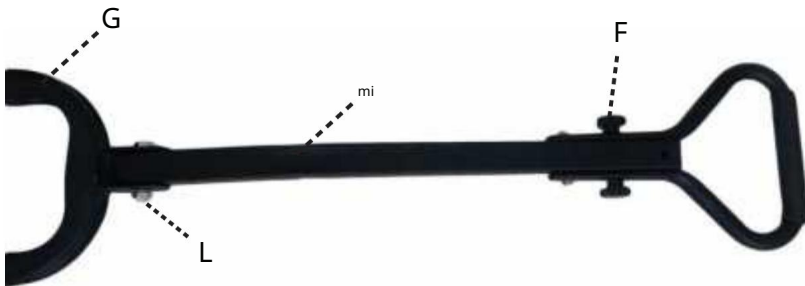
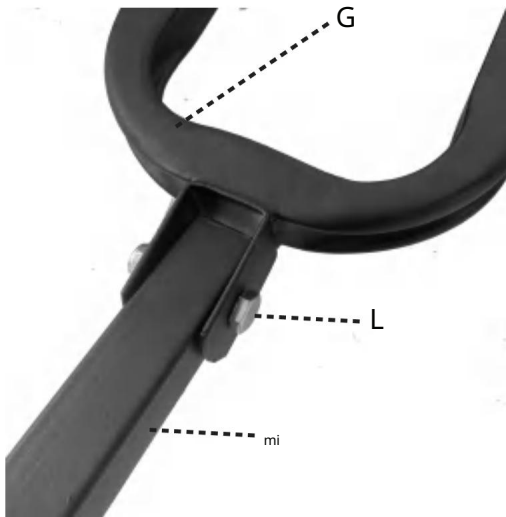

Krok 5: Umieść zmontowany wózek na kołach, następnie weź sekcje boczne (B) i sekcje końcowe (A), zabezpieczając je na miejscu za pomocą kołków R (M).

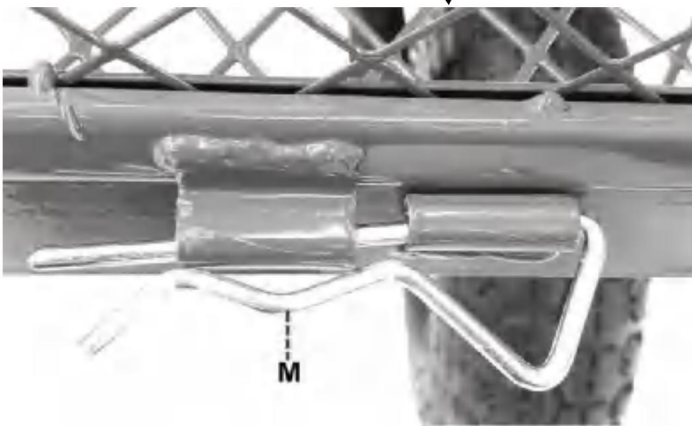
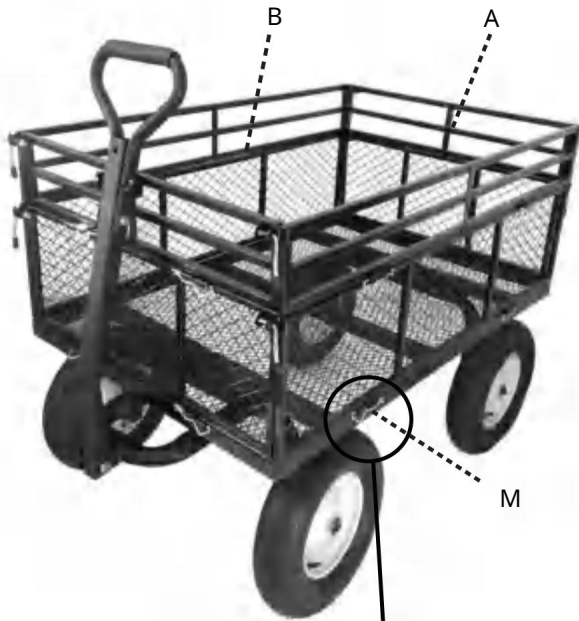

NOTATKA: Ensure the brackets are on the outside of the cart for keeping the sides and ends sitting flush.

UWAGA: Podnieś uchwyty blokujące, aby wyrównać je ze szczelinami na panelach bocznych. Aby zabezpieczyć, opuść uchwyty blokujące.

Krok 6: Po zwolnieniu uchwyty wózka można go również wykorzystać do trakcji i motor vehicle connection, only rotating the trolley handle upward and fix the handle on the upper hole with the five-star screen and nut.



Producent: Shanghai muxinmuyeyouxiangongsi

Adres: Shuangchenglu 803nong11hao1602A-1609shi, baoshanqu, szanghaj 200000 CN.

Importowane do AUS: SIHAO PTY LTD. 1 ROKEVA STRETEASTWOOD NSW 2122 Australia

Importowane do USA: Sanven Technology Ltd. Suite 250, 9166 Anaheim Place, Rancho Cucamonga, CA 91730



E-CrossStu GmbH
Mainzer Landstr.69, 60329 Frankfurt nad Menem.



YH CONSULTING LIMITED.
C/O YH Consulting Limited Biuro 147, Centurion House,
London Road, Staines-upon-Thames, Surrey, TW18 4AX

VEVOR[®]

TOUGH TOOLS, HALF PRICE

Wsparcie techniczne i certyfikat e-gwarancji

www.vevor.com/support

VEVOR[®]

TOUGH TOOLS, HALF PRICE

Technical Support and E-Warranty Certificate www.vevor.com/support

CARRELLO DA GIARDINO IN RETE

TC2024

MANUALE D'USO

Continuiamo a impegnarci per fornirvi strumenti a prezzi competitivi.

"Risparmia la metà", "Metà prezzo" o qualsiasi altra espressione simile da noi utilizzata rappresenta solo una stima del risparmio che potresti ottenere acquistando determinati utensili con noi rispetto ai principali marchi principali e non significa necessariamente coprire tutte le categorie di utensili da noi offerti. Ti ricordiamo gentilmente di verificare attentamente quando effettui un ordine con noi se stai effettivamente risparmiando la metà rispetto ai principali marchi principali.

VEVOR[®]

CARRELLO DA GIARDINO IN RETE

TC2024

MANUALE D'USO

TC2024



HAI BISOGNO DI AIUTO? CONTATTACI!

Have product questions? Need technical support? Please feel free per contattarci:

Supporto tecnico e certificato di garanzia elettronica www.vevor.com/support

Questa è l'istruzione originale. Si prega di leggere attentamente tutte le istruzioni del manuale prima di utilizzare il prodotto. La gestione del prodotto sarà soggetta al prodotto ricevuto. Si prega di scusarci se non vi informeremo di nuovo se ci sono aggiornamenti tecnologici o software sul nostro prodotto.

ISTRUZIONI DI SICUREZZA

AVVERTIMENTO:

1. Si prega di controllare e confermare che il carrello sia integro e che la pressione dei pneumatici sia normale prima di ogni utilizzo.
2. È vietato trasportare persone in qualsiasi condizione.
3. È vietato caricare articoli su terreni sconnessi e collinari.
4. Il sovraccarico è severamente vietato.
5. Non muoversi troppo velocemente quando si passa in zone con buche

ATTENZIONE: leggere attentamente le istruzioni e le procedure per operare in sicurezza.

MODELLO E PARAMETRI

Modello	TC2024
Carico statico massimo	1400 libbre
Pressione dei pneumatici	25-30 psi
Dimensioni del telaio	(1110±10) x (755±10) mm
Specifiche delle ruote (in)	16*4.00-8 Diametro * Larghezza-Dimensioni mozzo

COMPONENTI



A. Sezioni finali (x2)



B. Sezioni laterali (x2)



C. Ruote pneumatiche (x4)

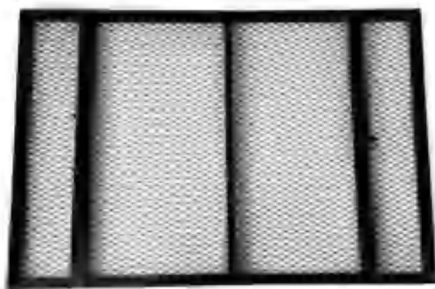

D. Base(x1)

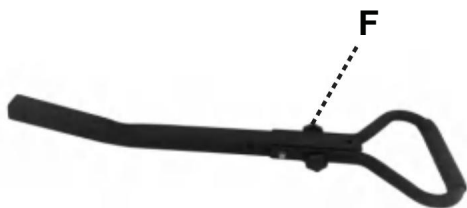

E. Maniglia(x1)



F. Vite a cinque stelle e dado (x1)



G. Staffa maniglia (x1)



H. Assale anteriore (x1)



I. Assale posteriore (x1)



J. Bulloni/Rondelle/Dadi (x2)



K. Dadi/rondelle in nylon grandi (M12x2+M18x1)



L. Bullone dado/Rondella (x1)



M. R-pin (x16)



O. Sezione pezzi di collegamento (x8)



N. Perni divisi (x4)



P. Rondelle per ruote (x4)



Q. Tappetino in gomma (x1)

ASSEMBLAGGIO

Fase 1: Fissare la staffa della maniglia (G) all'asse anteriore (H), utilizzando 2 bulloni/rondelle/dadi (J).

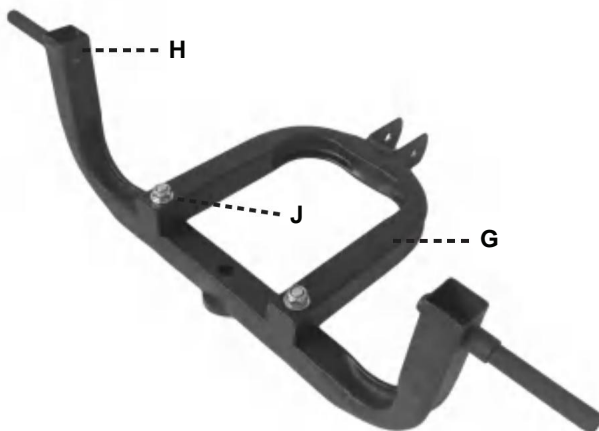

Fase 2: Prendi la base (D) e capovolgilà, in modo che i bulloni sporgenti siano rivolti verso l'alto.

E

Posizionare entrambi gli assi (H/I) sui bulloni, quindi serrare gli assi in posizione utilizzando i 2 grandi dadi/rondelle in nylon (K) come mostrato in figura.

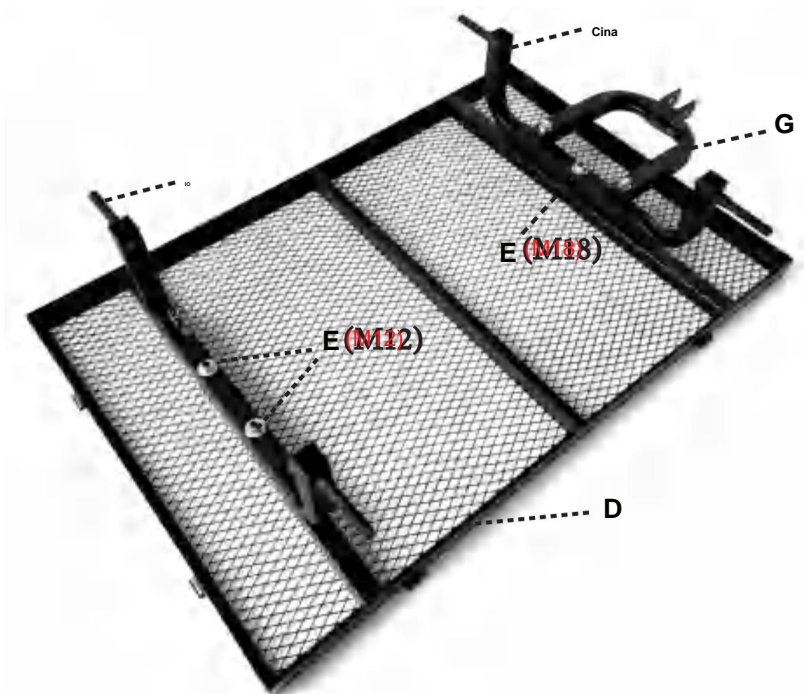

Fase 3: Fissare le 4 ruote pneumatiche (C) a ciascuna estremità della base assemblata, seguite dalla rondella della ruota (P).

Infilare la coppia (N) attraverso ciascuno dei fori e piegarla per fissarla in posizione.

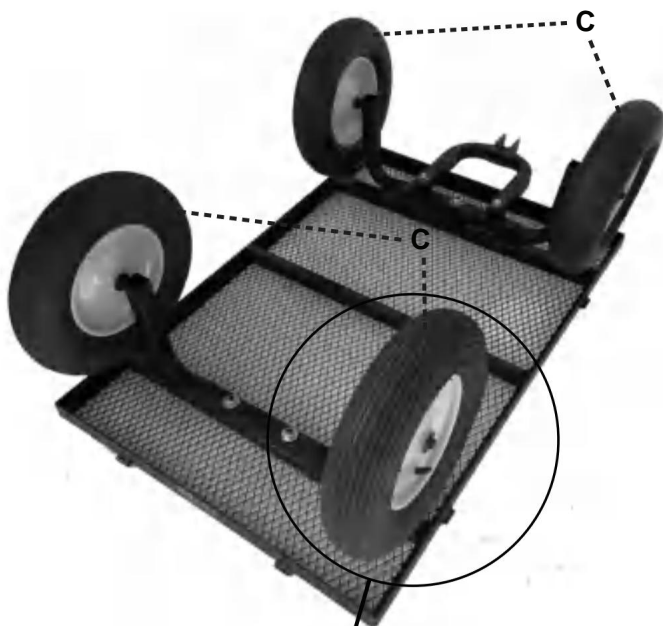

Fase 4: Rimuovere il bullone/rondella/dado (L(f)) dal blocco di plastica (F). Allineare la maniglia (E) e il blocco di plastica (L) (F) ai fori della staffa della maniglia (G).

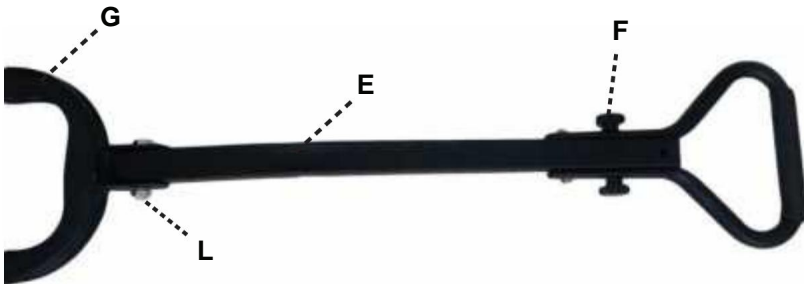
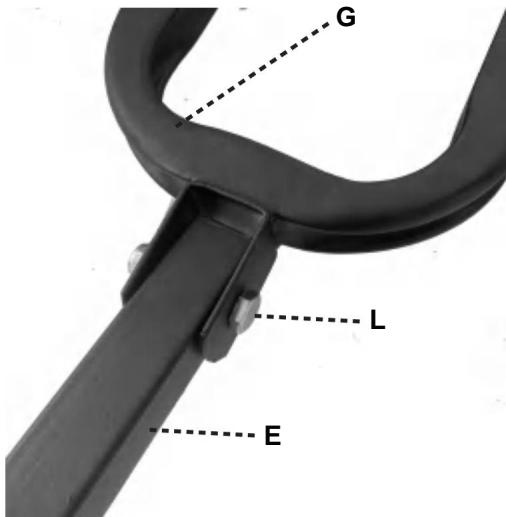

Fase 5: Posizionare il carrello assemblato sulle ruote, quindi prendere le sezioni laterali (B) e quelle terminali (A), fissandole in posizione utilizzando i perni a R (M).

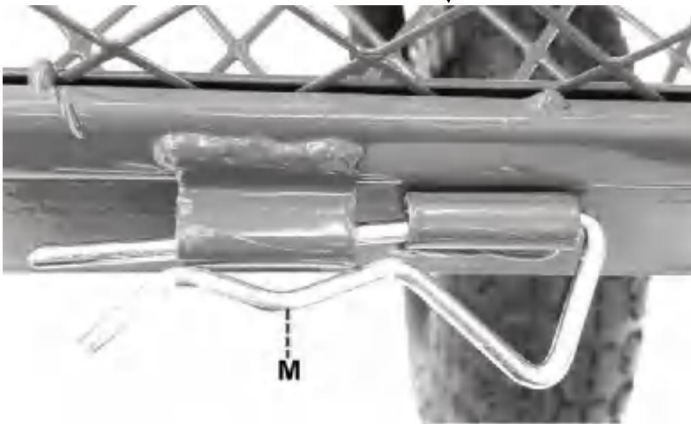

NOTA: Ensure the brackets are on the outside of the cart for keeping the sides and ends sitting flush.

NOTA: sollevare le maniglie di bloccaggio per allinearle con le fessure sui pannelli laterali.
Per fissare, abbassare le maniglie di bloccaggio.

Fase 6: Dopo aver rilasciato la maniglia del carrello, può essere utilizzata anche per la trazione e motor vehicle connection, only rotating the trolley handle upward and fix the handle on the upper hole with the five-star screen and nut.



Produttore: Shanghaimuxinmuyeyouxiangongsi

Indirizzo: Shuangchenglu 803nong11hao1602A-1609shi, baoshanqu, shanghai 200000 CN.

Importato in AUS: SIHAO PTY LTD. 1 ROKEVA STREETEASTWOOD NSW 2122 Australia

Importato negli USA: Sanven Technology Ltd. Suite 250, 9166 Anaheim Place, Rancho Cucamonga, CA 91730



E-CrossStu GmbH
Mainzer Landstr.69, 60329 Francoforte sul Meno.



CONSULENZA YH LIMITATA.
C/O YH Consulting Limited Ufficio 147, Centurion House,
Via Roma, 101, 00186 Roma, Italia

VEVOR[®]

TOUGH TOOLS, HALF PRICE

Supporto tecnico e certificato di garanzia elettronica

www.vevor.com/support

VEVOR[®]

TOUGH TOOLS, HALF PRICE

Technical Support and E-Warranty Certificate www.vevor.com/support

CARRITO DE JARDÍN DE MALLA

TC2024

MANUAL DEL USUARIO

Seguimos comprometidos a brindarle herramientas a precios competitivos.

"Ahorre la mitad", "mitad de precio" o cualquier otra expresión similar que utilicemos solo representa una estimación del ahorro que podría obtener al comprar ciertas herramientas con nosotros en comparación con las principales marcas y no necesariamente significa que cubra todas las categorías de herramientas que ofrecemos. Le recordamos que, al realizar un pedido con nosotros, verifique cuidadosamente si realmente está ahorrando la mitad en comparación con las principales marcas.

VEVOR[®]

CARRITO DE JARDÍN DE MALLA
TC2024
MANUAL DEL USUARIO

TC2024



¿NECESITA AYUDA? ¡CONTÁCTENOS!

Have product questions? Need technical support? Please feel free Para contactarnos:

Soporte técnico y certificado de garantía electrónica www.vevor.com/support

Estas son las instrucciones originales. Lea atentamente todas las instrucciones del manual antes de utilizar el producto. El rendimiento del producto dependerá del producto que haya recibido. Perdónenos por no informarle nuevamente si hay actualizaciones de tecnología o software en nuestro producto. The app

INSTRUCCIONES DE SEGURIDAD

ADVERTENCIA:

1. Verifique y confirme que el carrito esté intacto y que la presión de los neumáticos sea la adecuada. normal antes de cada uso.
2. Está prohibido transportar personas en cualquier condición.
3. Está prohibido cargar artículos en terrenos irregulares o accidentados.
4. La sobrecarga está estrictamente prohibida.
5. No te muevas demasiado rápido al pasar por zonas con baches.

PRECAUCIÓN: Lea atentamente las instrucciones y los procedimientos para realizar operaciones seguras.

MODELO Y PARÁMETROS

Modelo	TC2024
Carga estática máxima	1400 libras
Presión de los neumáticos	25-30 psi
Tamaño del marco	(1110 ± 10) x (755 ± 10) mm
Especificación de ruedas (pulgadas)	16*4.00-8 (diámetro x ancho del eje)

COMPONENTES



A. Secciones finales (x2)



B. Secciones laterales (x2)



C. Ruedas neumáticas (x4)

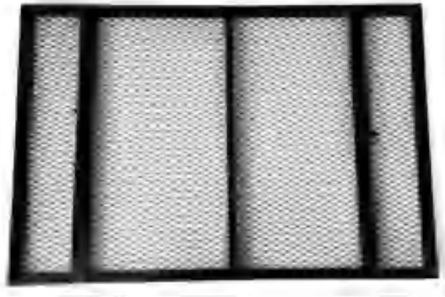

D. Base (x1)

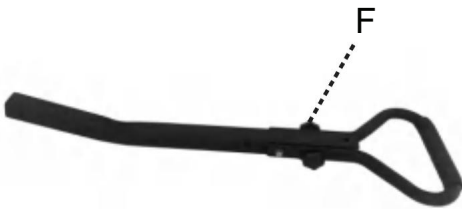

E. Mango (x1)



F. Tornillo de estrella de cinco puntas y tuerca (x1)



G. Soporte de manija (×1)



H. Eje delantero (×1)



I. Eje trasero (×1)



J. Pernos/Arandelas/Tuercas (×2)



K. Tuercas/arandelas de nailon grandes (M12x2+M18x1)



L. Tuerca de perno/arandela (×1)



M. Pines R (x16)



O. Piezas de enlace de sección (x8)



N. Pasadores partidos (x4)



P. Lavadoras de ruedas (x4)



Q. Alfombrilla de goma (x1)

ASAMBLEA

Paso 1: Fije el soporte del mango (G) al eje delantero (H), usando los 2 pernos/ arandelas/ tuercas (J).

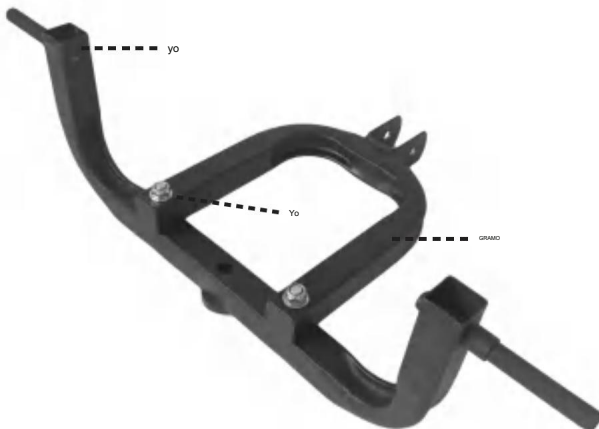

Paso 2: Tome la base (D) y gírela hacia abajo, de modo que los pernos que sobresalen queden hacia arriba.

K

Coloque ambos ejes (H/I) en los pernos, seguidos de los ejes ajustados en su lugar, usando las 2 tuercas/arandelas de nailon grandes (K) como se muestra.

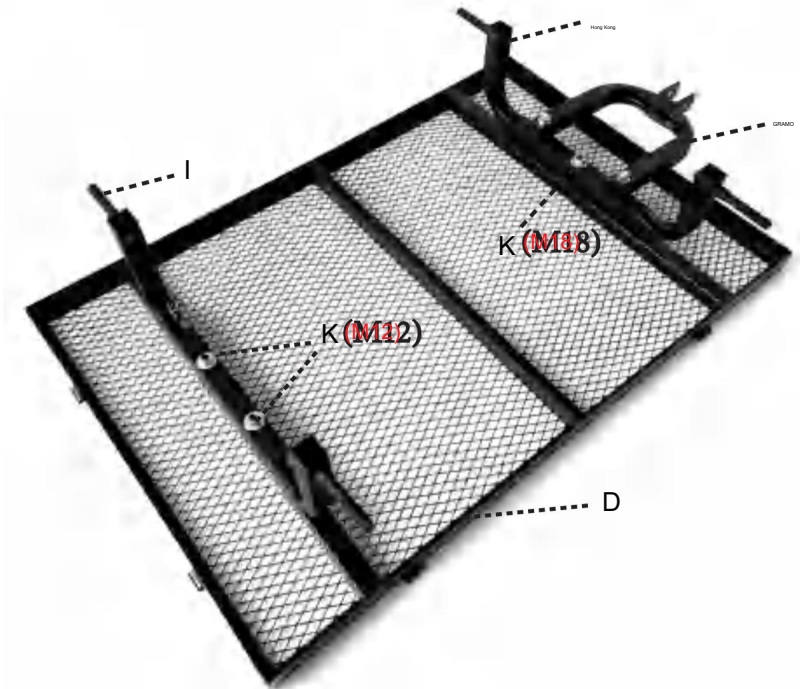

Paso 3: Coloque las 4 ruedas neumáticas (C) en cada extremo de la base ensamblada, seguidas de la arandela de la rueda (P).

Pase el pasador partido (N) a través de cada uno de los orificios y dóblelos para asegurarlos en su lugar.

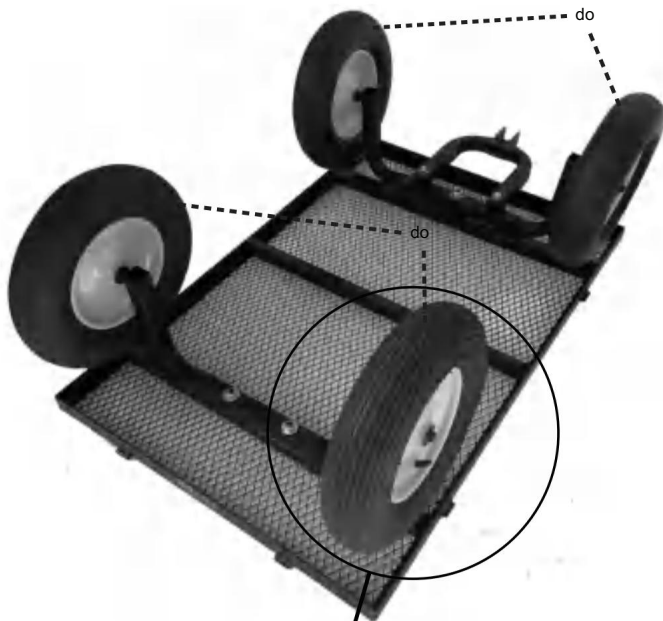

Paso 4: Retire el perno/arandela/tuerca (L(f)) del bloque de plástico (F).
Alinee el mango (E) y el bloque de plástico (L) (F) con los orificios del soporte del mango (G).

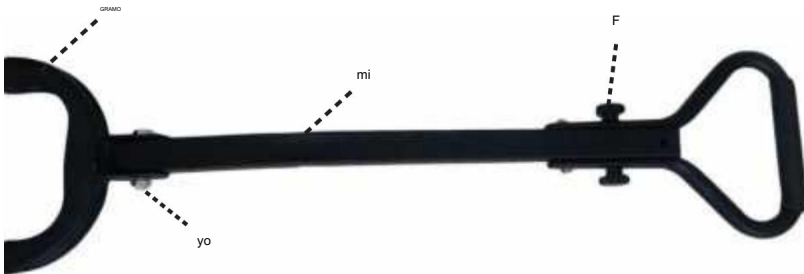

Paso 5: Coloque el carrito ensamblado sobre sus ruedas, luego tome las secciones laterales (B) y las secciones de los extremos (A), asegurándolas en su lugar usando los pasadores R (M).

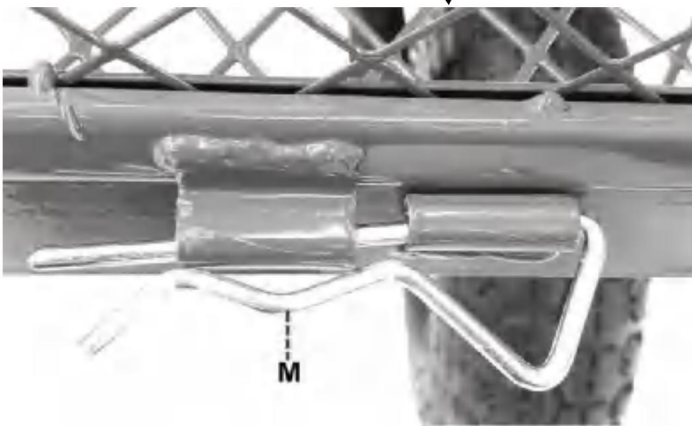

NOTA: Ensure the brackets are on the outside of the cart for keeping the sides and ends sitting flush.

NOTA: Levante las manijas de bloqueo para alinearlas con las ranuras de los paneles laterales. Baje las manijas de bloqueo para asegurarlas.

Paso 6: Después de soltar el mango del carro, también se puede utilizar para tracción y motor vehicle connection, only rotating the trolley handle upward and fix the handle on the upper hole with the five-star screen and nut.



Fabricante: Shanghai muxinmuyeyouxiangongsi

Dirección: Shuangchenglu 803nong11hao1602A-1609shi, baoshanqu, shanghai 200000 CN.

Importado a AUS: SIHAO PTY LTD. 1 ROKEVA STREET EASTWOOD NSW 2122 Australia

Importado a EE. UU.: Sanven Technology Ltd. Suite 250, 9166 Anaheim Place, Rancho Cucamonga, CA 91730



E-CrossStu GmbH
Mainzer Landstr.69, 60329 Fráncfort del Meno.



YH CONSULTING LIMITADA.
C/O YH Consulting Limited Oficina 147, Centurion House,
Carretera de Londres, Staines-upon-Thames, Surrey, TW18 4AX

VEVOR[®]

TOUGH TOOLS, HALF PRICE

Soporte técnico y certificado de garantía electrónica

www.vevor.com/support

VEVOR[®]

TOUGH TOOLS, HALF PRICE

Technical Support and E-Warranty Certificate www.vevor.com/support

TRÄDGÅRDSKÄRG MED NETT

TC2024

ANVÄNDARMANUAL

Vi fortsätter att vara engagerade i att ge dig verktyg till konkurrenskraftiga priser.

"Spara hälften", "halva priset" eller andra liknande uttryck som används av oss representerar bara en uppskattning av besparingar du kan dra nytta av att köpa vissa verktyg hos oss jämfört med de stora toppmärkena och betyder inte nödvändigtvis att täcka alla kategorier av verktyg som erbjuds av oss. Du påminns vänligen om att noggrant kontrollera när du gör en beställning hos oss om du faktiskt sparar hälften i jämförelse med de främsta stora varumärkena.

VEVOR®

TRÄDGÅRDSKÄRG MED NETT

TC2024

ANVÄNDARMANUAL

TC2024



BEHÖVER HJÄLP? KONTAKTA OSS!

Have product questions? Need technical support? Please feel free att kontakta oss:

Teknisk support och e-garanticertifikat www.vevor.com/support

Detta är den ursprungliga instruktionen. Vänligen läs alla bruksanvisningar noggrant innan du använder den.

VEVOR reserves clear interpretation of our user manual. The appearance av produkten ska vara föremål för den produkt du mottagit. Ursäkta oss att vi inte kommer att informera dig igen om det finns någon teknik eller mjukvaruuppdateringar på vår produkt.

SÄKERHETSINSTRUKTIONER

VARNING:

1. Kontrollera och bekräfta att vagnen är hel och att däcktrycket är normalt före varje användning.
2. Det är förbjudet att transportera människor under alla förhållanden.
3. Det är förbjudet att lasta föremål i ojämna och kuperade terräng.
4. Överbelastning är strängt förbjuden.
5. Rör dig inte för snabbt när du passerar gropar

VARNING: Läs noggrant instruktionerna och procedurerna för säker användning.

MODELL OCH PARAMETRAR

Modell	TC2024
Maximal statisk belastning	1400 pund
Däcktryck	25-30psi
Ramstorlek	1110±10x755±10mm
Hjulspecifikation(in)	16*4.00-8Dia. * Bredd-navstorlek

KOMPONENTER



A. Slutsektioner (x2)



B. Sidosektioner (x2)



C. Pneumatiska hjul (x4)

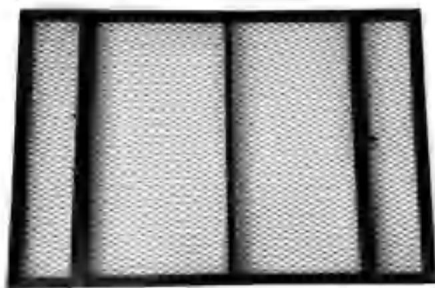

D. Bas (x1)

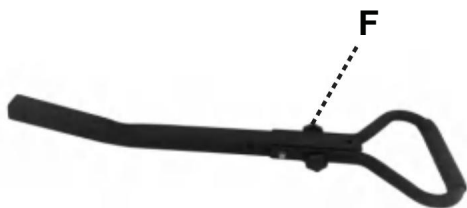

E. Handtag (x1)



F. Femstjärnig skruv och mutter (x1)



G. Handtagsfäste (x1)



H. Framaxel (x1)



I. Bakaxel (x1)



J. Bultar/Brickor/Muttrar (x2)



K. Stora nylonmuttrar/brickor (M12x2+M18x1)



L. Bultmutter/bricka (x1)



M. R-stift (x16)



O. Sektionslänkbitar (x8)



N. Delade stift (x4)



P. Hjulbrickor (x4)



Q. Gummimatta(x1)

MONTERING

Steg 1: Fäst handtagsfästet (G) på framaxeln (H), med hjälp av de två bultarna/brickorna/muttrarna (J).

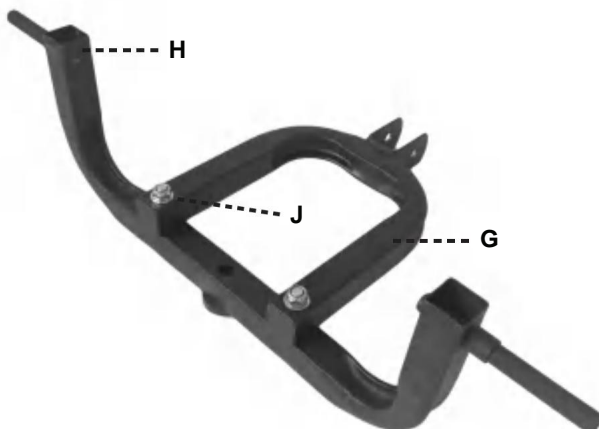

Steg 2: Ta basen(D) och vänd den upp och ner så att de utskjutande bultarna är vända uppåt.

K

Placera båda axlarna (H/I) på bultarna, följt av täta axlar på platsen, med hjälp av de 2 stora nylonmuttrarna/brickorna (K) enligt bilden.

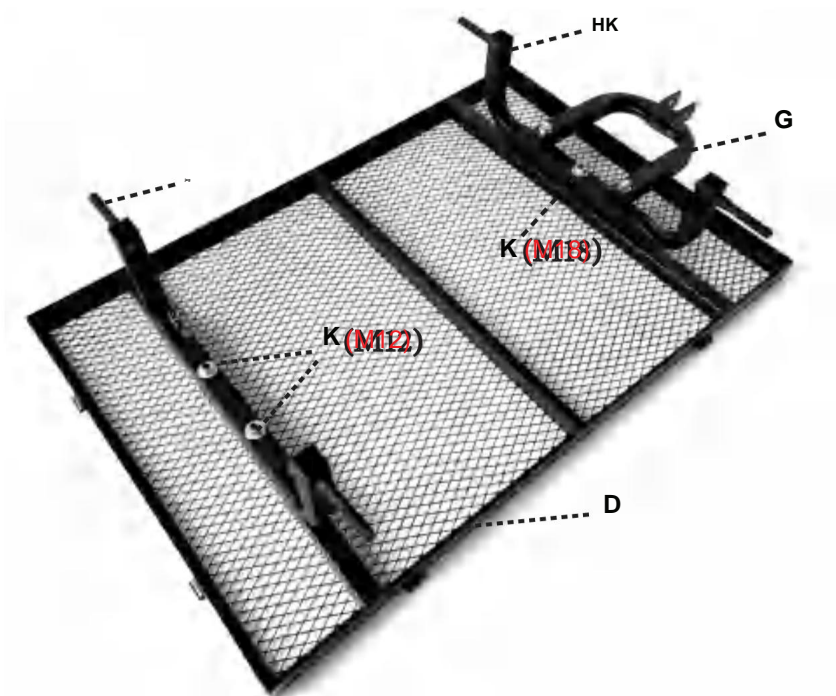

Steg 3: Fäst de 4 pneumatiska hjulen (C) vid varje ände av den monterade basen, följt av hjulbrickan (P).

Trä delad stift (N) genom vart och ett av hålen och böj för att säkra dem på plats.

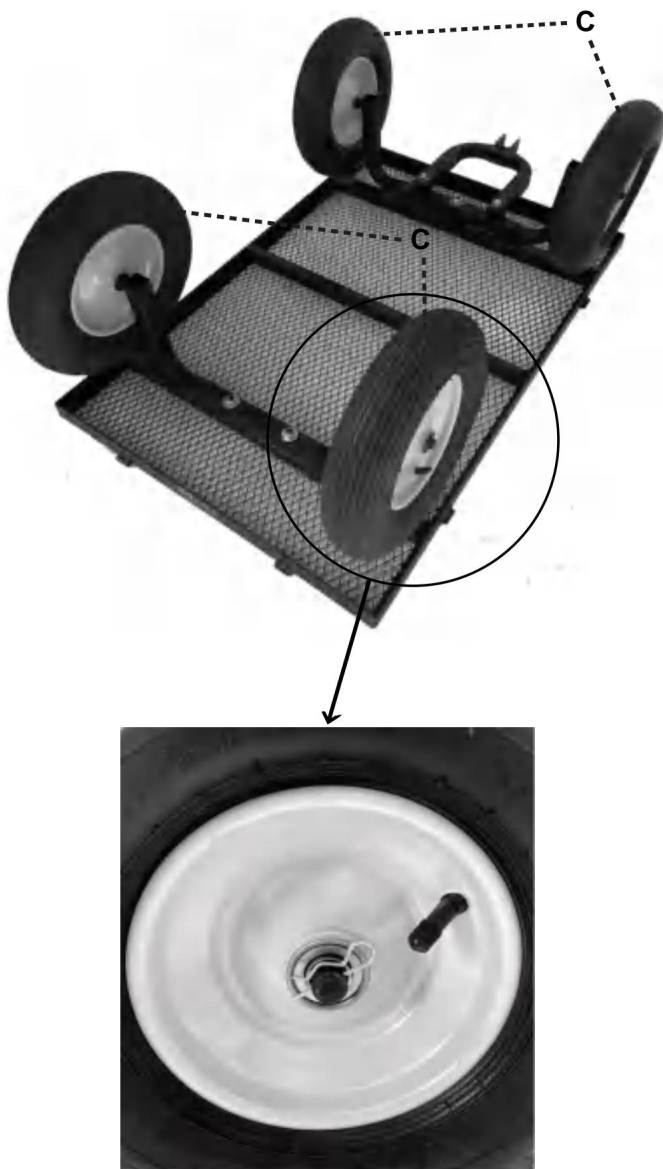

Steg 4: Ta bort bulten/brickan/muttern (L(f)) från plastblocket (F). Rikta in handtaget (E) och plastblocket (L)(F) mot hålen på handtagsfästet (G).

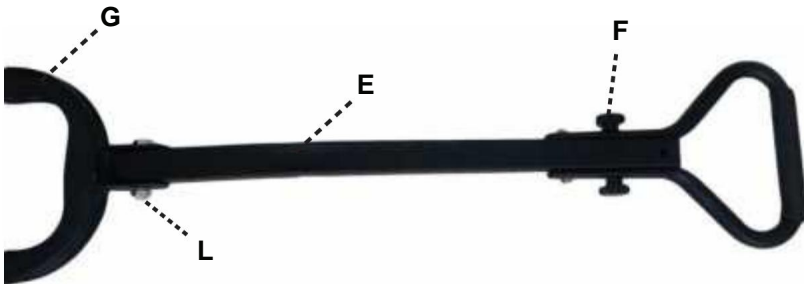
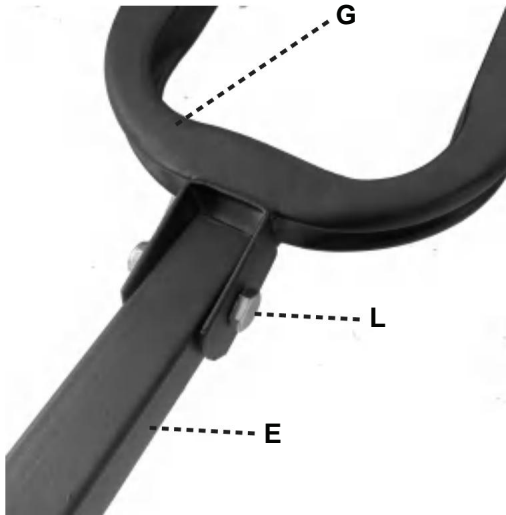

Steg 5: Sätt den monterade vagnen på dess hjul, ta sedan sidosektionerna (B) och ändsektionerna (A), och säkra dem på plats med hjälp av R-stiften (M).

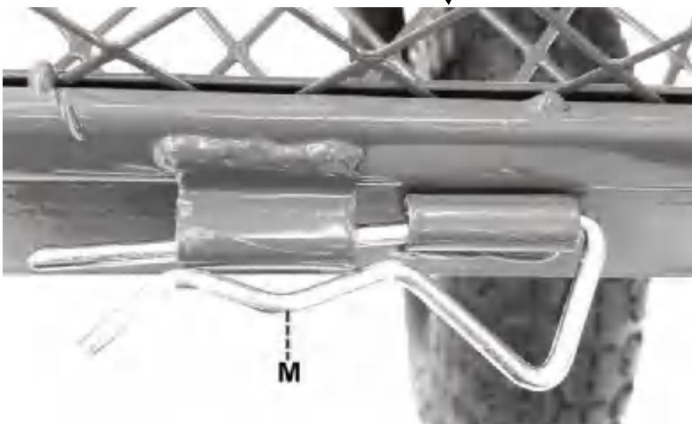
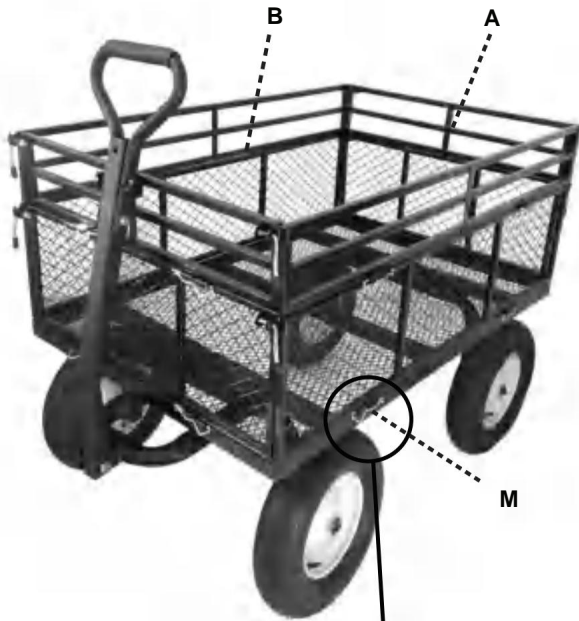

NOTERA: Ensure the brackets are on the outside of the cart for keeping the sides and ends sitting flush.

OBSERVERA: Lyft låshandtagen så att de kommer i linje med skårorna på sidopanelerna. Sänk låshandtagen för att säkra.

Steg 6: Efter att ha släppt vagnens handtag kan den även användas för dragkraft och motor vehicle connection, only rotating the trolley handle upward and fix the handle on the upper hole with the five-star screen and nut.



Tillverkare: Shanghaimuxinmuyeyouxiangongsi

Adress: Shuangchenglu 803nong11hao1602A-1609shi, baoshanqu, shanghai 200000 CN.

Importerad till AUS: SIHAO PTY LTD. 1 ROKEVA STREETEASTWOOD NSW 2122 Australien

Importerad till USA: Sanven Technology Ltd. Suite 250, 9166 Anaheim Place, Rancho Cucamonga, CA 91730



E-CrossStu GmbH
Mainzer Landstr.69, 60329 Frankfurt am Main.



YH CONSULTING LIMITED.
C/O YH Consulting Limited Office 147, Centurion House,
London Road, Staines-upon-Thames, Surrey, TW18 4AX

VEVOR[®]

TOUGH TOOLS, HALF PRICE

Teknisk support och e-garanticertifikat

www.vevor.com/support

VEVOR[®]

TOUGH TOOLS, HALF PRICE

Technical Support and E-Warranty Certificate www.vevor.com/support

MESH TUINWAGEN

TC2024

GEbruikersHANDLEIDING

Wij streven er voortdurend naar om u gereedschappen tegen concurrerende prijzen te leveren.

"Save Half", "Half Price" of andere soortgelijke uitdrukkingen die wij gebruiken, geven alleen een schatting van de besparingen die u kunt behalen door bepaalde gereedschappen bij ons te kopen in vergelijking met de grote topmerken en betekent niet noodzakelijkerwijs dat alle categorieën gereedschappen die wij aanbieden, worden gedekt. Wij herinneren u eraan om zorgvuldig te controleren of u daadwerkelijk de helft bespaart in vergelijking met de grote topmerken wanneer u een bestelling bij ons plaatst.

VEVOR[®]

MESH TUINWAGEN
TC2024

GEBRUIKERSHANDLEIDING

TC2024



HULP NODIG? NEEM CONTACT MET ONS OP!

Have product questions? Need technical support? Please feel free om contact met ons op te nemen:

Technische ondersteuning en e-garantiecertificaat www.vevor.com/support

Dit is de originele instructie. Lees alle handleidingen zorgvuldig door voordat u het product gebruikt. De kwaliteit van het product is afhankelijk van het product dat u hebt ontvangen. Vergeef ons dat we u niet opnieuw zullen informeren als er technologie- of software-updates voor ons product zijn.

VEILIGHEIDSINSTRUCTIES

WAARSCHUWING:

1. Controleer en bevestig dat de kar intact is en dat de bandenspanning correct is. normaal voor elk gebruik.
2. Het is verboden om personen te vervoeren, ongeacht de omstandigheden.
3. Het is verboden om goederen te laden op oneffen en heuvelachtig terrein.
4. Overbelasting is ten strengste verboden.
5. Rijd niet te snel als u door kuilen rijdt

LET OP: Lees de instructies en procedures zorgvuldig door voor veilige bediening.

MODEL EN PARAMETERS

Model	TC2024
Maximale statische belasting	1400 pond
Bandenspanning	25-30psi
Framemaat	(1110±10) x (755±10) mm
Wielspecificatie(in)	16*4.00-8 (Dia. * Breedte-naafmaat)

COMPONENTEN



A. Einddelen (x2)



B. Zijdelen (x2)



C. Luchtbanden (x4)

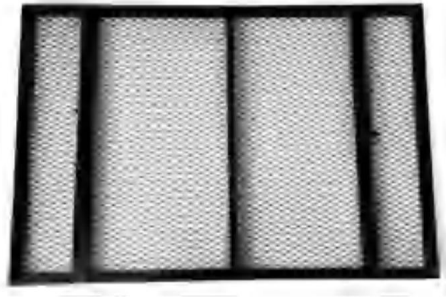

D. Basis (x1)

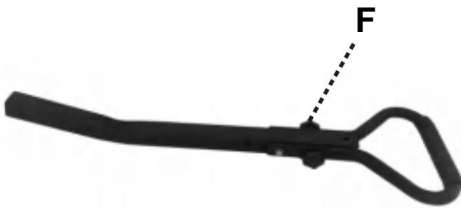

E. Handvat (x1)



F. Vijfsterrenschroef en moer (x1)



G. Handvatbeugel (x1)



H. Vooras (x1)



I. Achteras (x1)



J. Bouten/ringen/moeren (x2)



K. Grote nylon moeren/ringen (M12x2+M18x1)



L. Boutmoer/ring (x1)



M. R-pinnen (x16)



O. Sectieverbindingsstukken (x8)



N. Splitpennen (x4)



P. Wielwassers (x4)



V. Rubberen mat (x1)

MONTAGE

Stap 1: Bevestig de handgreepbeugel (G) aan de vooras (H) met behulp van 2 bouten/ringen/moeren (J).

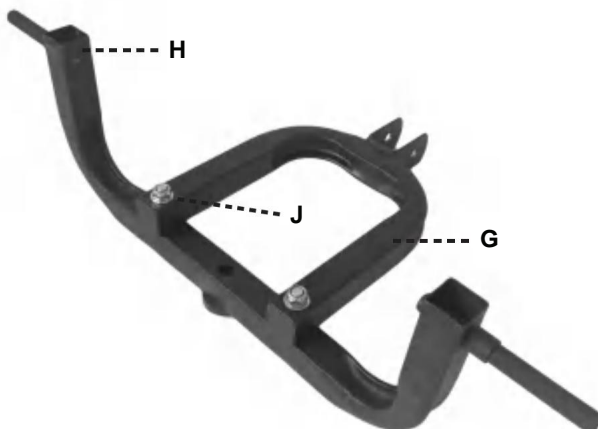

Stap 2: Neem de basis (D) en draai deze ondersteboven, zodat de uitstekende bouten naar boven wijzen.

Ik

Plaats beide assen (H/I) op de bouten en draai de assen vervolgens vast met behulp van de 2 grote nylon moeren/ringen (K) zoals afgebeeld.

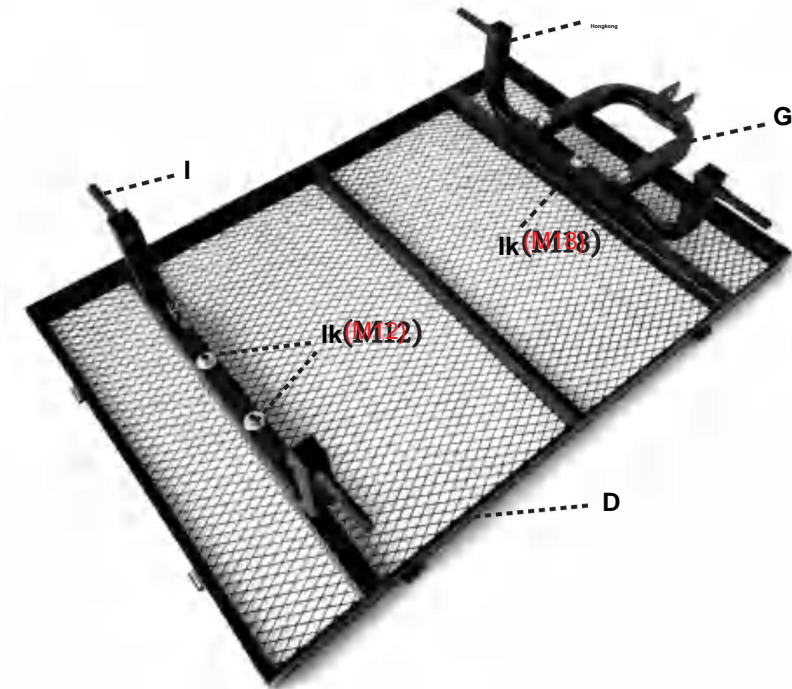

Stap 3: Bevestig de 4 luchtbanden (C) aan elk uiteinde van de gemonteerde basis, gevolgd door de wielring (P).

Steek de splitpen (N) door elk gat en buig deze om zodat ze vastzitten.

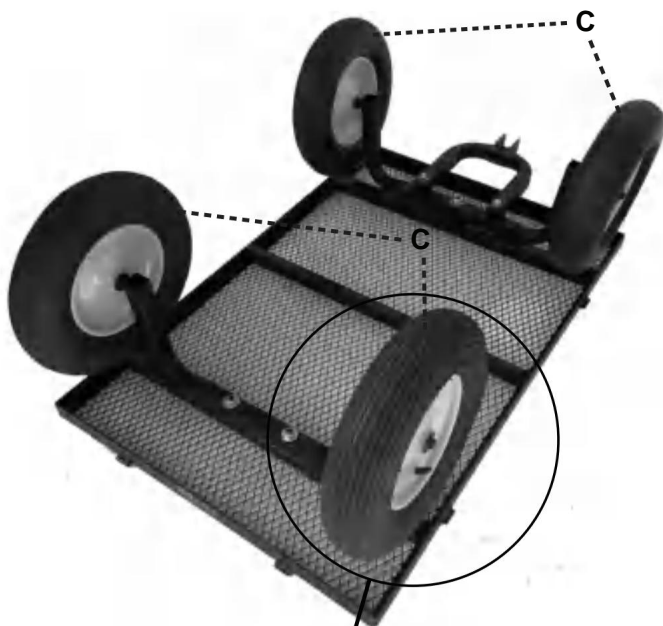

Stap 4: Verwijder de bout/ring/moer (L(f)) van het kunststof blok (F).
Lijn de handgreep (E) en het kunststof blok (L) (F) uit met de gaten in de handgreepbeugel (G).

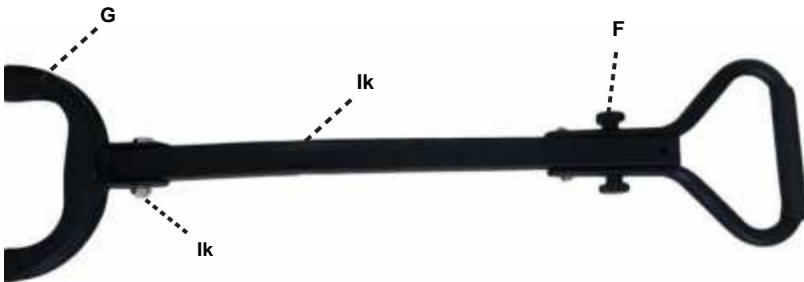
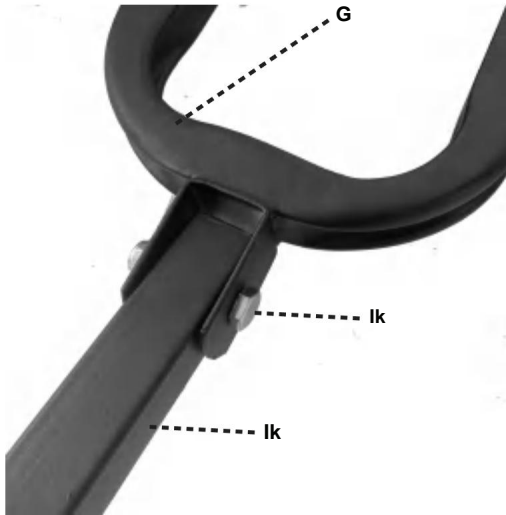

Stap 5: Zet de gemonteerde kar op de wielen en neem vervolgens de zijdelen (B) en de einddelen (A). Bevestig deze met de R-pennen (M).

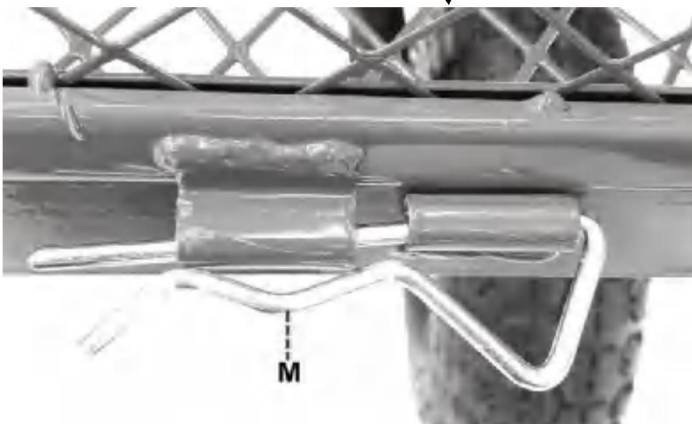
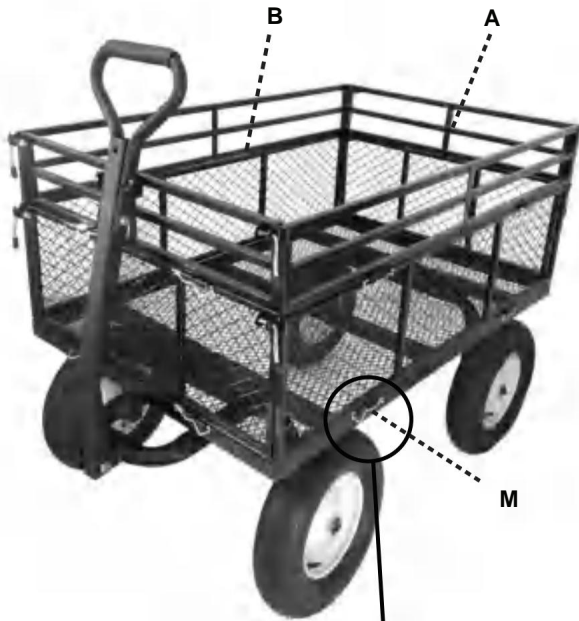

OPMERKING: Ensure the brackets are on the outside of the cart for keeping the sides and ends sitting flush.

OPMERKING: Til de vergrendelingshendels op totdat ze op één lijn liggen met de sleuven in de zijpanelen.

Zet de vergrendelingshendels omlaag om ze vast te zetten.

Stap 6: Nadat u de trolleyhendel hebt losgelaten, kan deze ook worden gebruikt voor tractie en motor vehicle connection, only rotating the trolley handle upward and fix the handle on the upper hole with the five-star screen and nut.



Fabrikant: Shanghaimuxinmuyeyouxiangongsi

Adres: Shuangchenglu 803nong11hao1602A-1609shi, baoshanqu, shanghai 200000 CN.

Geïmporteerd naar AUS: SIHAO PTY LTD. 1 ROKEVA STREETEASTWOOD NSW 2122 Australië

Geïmporteerd naar de VS: Sanven Technology Ltd. Suite 250, 9166 Anaheim Place, Rancho Cucamonga, CA 91730



E-CrossStu GmbH
Mainzer Landstr.69, 60329 Frankfurt am Main.



YH CONSULTING LIMITED.
C/O YH Consulting Limited Kantoor 147, Centurion House,
Londen Road, Staines-upon-Thames, Surrey, TW18 4AX

VEVOR[®]

TOUGH TOOLS, HALF PRICE

Technische ondersteuning en e-garantiecertificaat

www.vevor.com/support

VEVOR[®]

TOUGH TOOLS, HALF PRICE

Technical Support and E-Warranty Certificate www.vevor.com/support

CHARIOT DE JARDIN EN MAILLE

TC2024

MANUEL D'UTILISATION

Nous continuons à nous engager à vous fournir des outils à des prix compétitifs.

« Économisez la moitié », « Moitié prix » ou toute autre expression similaire utilisée par nous ne représente qu'une estimation des économies que vous pourriez réaliser en achetant certains outils chez nous par rapport aux grandes marques et ne couvre pas nécessairement toutes les catégories d'outils que nous proposons. Nous vous rappelons de bien vouloir vérifier soigneusement lorsque vous passez une commande chez nous si vous économisez réellement la moitié par rapport aux grandes marques.

VEVOR®

CHARIOT DE JARDIN EN MAILLE
TC2024
MANUEL D'UTILISATION

TC2024



BESOIN D'AIDE? CONTACTEZ-NOUS!

Have product questions? Need technical support? Please feel free pour nous contacter :

Assistance technique et certificat de garantie électronique www.vevor.com/support

Il s'agit de la notice d'origine. Veuillez lire attentivement toutes les instructions du manuel avant de l'utiliser. La garantie du produit dépend du VEVOR reserves clear interpretation of our user manual. The app
produit que vous avez reçu. Veuillez nous excuser, nous ne vous informerons plus si des mises à jour technologiques ou logicielles sont disponibles sur notre produit.

CONSIGNES DE SÉCURITÉ

AVERTISSEMENT:

1. Veuillez vérifier et confirmer que le chariot est intact et que la pression des pneus est normal avant chaque utilisation.
2. Il est interdit de transporter des personnes dans n'importe quelles conditions.
3. Il est interdit de charger des objets sur des terrains accidentés et vallonnés.
4. La surcharge est strictement interdite.
5. Ne vous déplacez pas trop vite lorsque vous passez dans des zones de nids-de-poule

ATTENTION : Lisez attentivement les instructions et les procédures pour des opérations en toute sécurité.

MODÈLE ET PARAMÈTRES

Modèle	TC2024
Charge statique maximale	1400 lb
Pression des pneus	25-30 psi
Taille du cadre	(1110±10)x(755±10)mm
Spécifications des roues (po)	16*4.00-8 (Dia. * Largeur-Taille du moyeu)

COMPOSANTS



A. Sections d'extrémité (×2)



B. Sections latérales (×2)



C. Roues pneumatiques (×4)

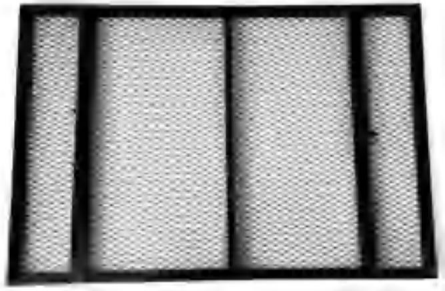

D. Base (×1)

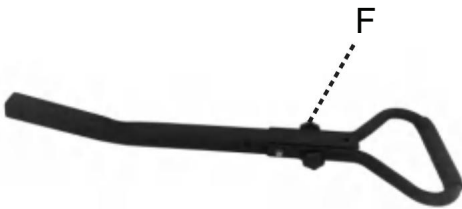

E. Poignée (×1)



F. Vis et écrou cinq étoiles (×1)



G. Support de poignée (x1)



H. Essieu avant (x1)



I. Essieu arrière (x1)



J. Boulons/Rondelles/Écrous (x2)



K. Grands écrous/rondelles en nylon (M12x2+M18x1)



L. Écrou de boulon/rondelle (x1)



M. Broches R (×16)



O. Pièces de liaison de section (×8)



N. Goupilles fendues (×4)



P. Rondelles de roue (×4)



Q. Tapis en caoutchouc (×1)

ASSEMBLÉE

Étape 1 : Fixez le support de poignée (G) à l'essieu avant (H), à l'aide de 2 boulons/rondelles/écrous (J).

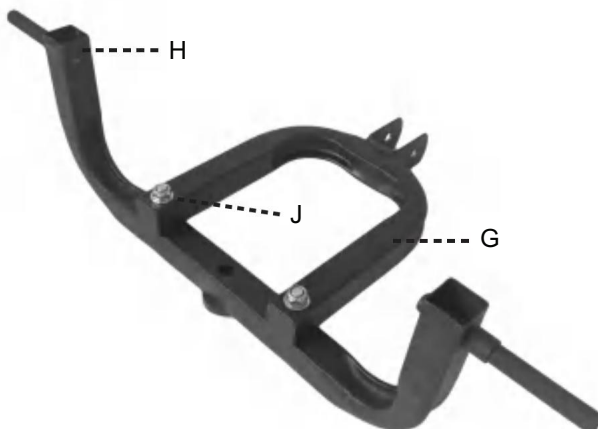

Étape 2 : Prenez la base (D) et retournez-la, de sorte que les boulons saillants soient orientés vers le haut.

K

Placez les deux essieux (H/I) sur les boulons, suivis des essieux serrés en place, en utilisant les 2 gros écrous/rondelles en nylon (K) comme indiqué.

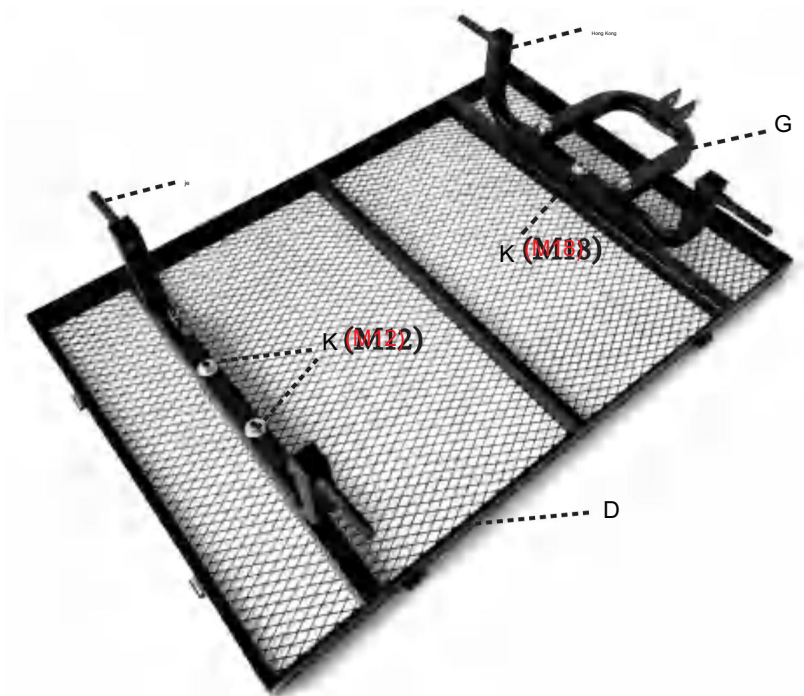

Étape 3 : Fixez les 4 roues pneumatiques (C) à chaque extrémité de la base assemblée, suivies de la rondelle de roue (P).

Enfilez la goupille fendue (N) dans chacun des trous et pliez-la pour les fixer en place.

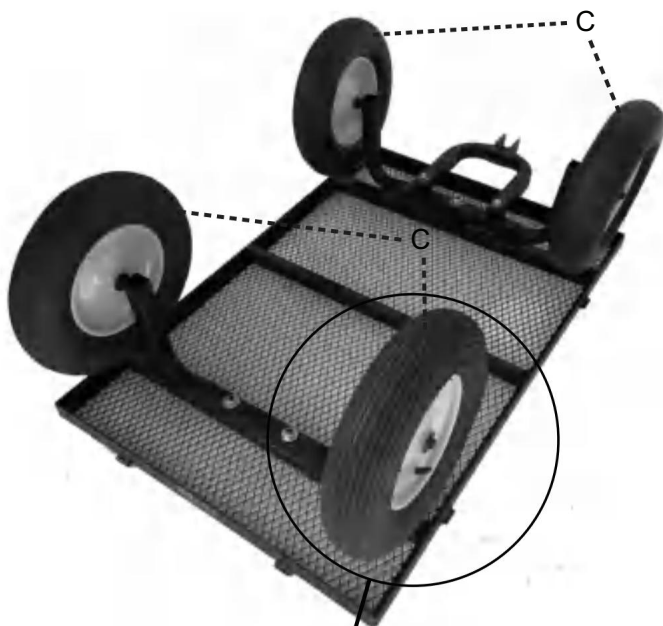

Étape 4 : Retirez le boulon/la rondelle/l'écrou (L(f)) du bloc en plastique (F).
Alignez la poignée (E) et le bloc en plastique (L)(F) sur les trous du support de poignée (G).

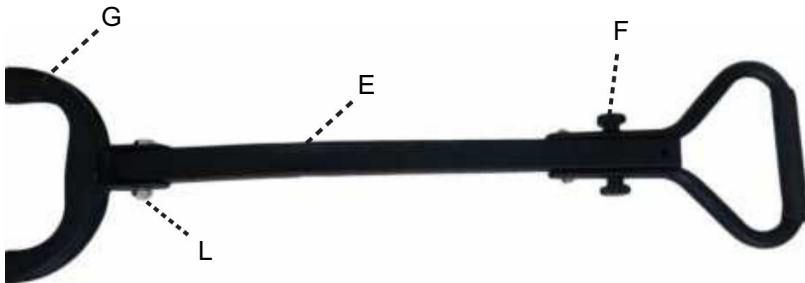
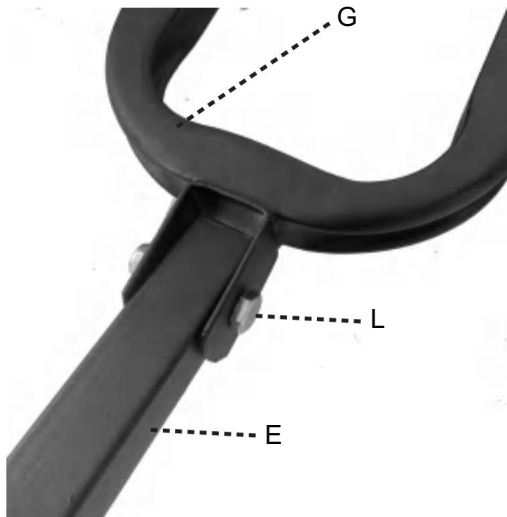

Étape 5 : Placez le chariot assemblé sur ses roues, puis prenez les sections latérales (B) et les sections d'extrémité (A), en les fixant en place à l'aide des broches en R (M).

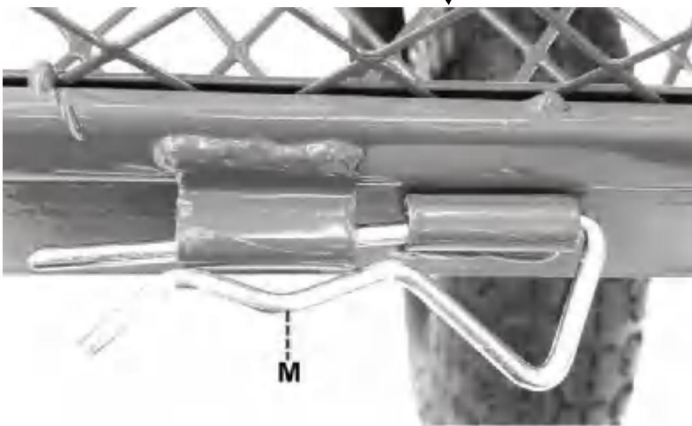
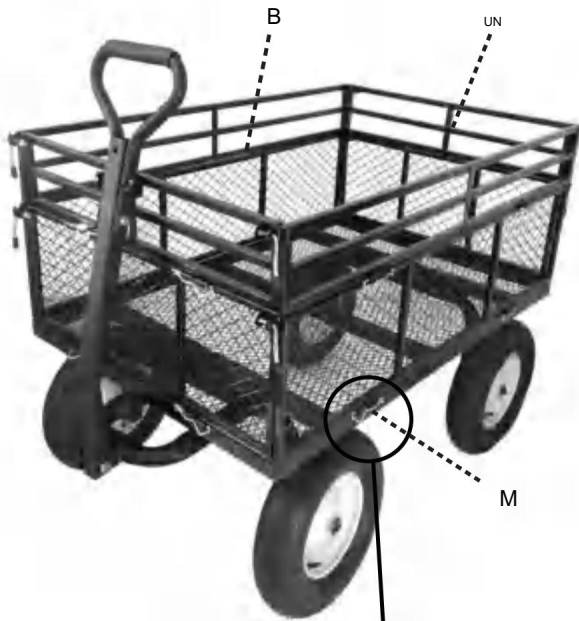

NOTE: Ensure the brackets are on the outside of the cart for keeping the sides and ends sitting flush.

REMARQUE : Soulevez les poignées de verrouillage pour les aligner avec les fentes des panneaux latéraux.
Abaissez les poignées de verrouillage pour sécuriser.

Étape 6 : Après avoir relâché la poignée du chariot, elle peut également être utilisée pour la traction et
motor vehicle connection, only rotating the trolley handle upward and fix the handle on the upper hole with the five-star screen and nut.



Fabricant : Shanghaimuxinmuyeyouxiangongsi

Adresse : Shuangchenglu 803nong11hao1602A-1609shi, baoshanqu, shanghai 200000 CN.

Importé en Australie : SIHAO PTY LTD. 1 ROKEVA STREETEASTWOOD NSW 2122 Australie

Importé aux États-Unis : Sanven Technology Ltd. Suite 250, 9166 Anaheim Place, Rancho Cucamonga, CA 91730



E-CrossStu GmbH
Mainzer Landstr.69, 60329 Francfort-sur-le-Main.



YH CONSULTING LIMITÉE.
C/O YH Consulting Limited Bureau 147, Centurion House,
Route de Londres, Staines-upon-Thames, Surrey, TW18 4AX

VEVOR[®]

TOUGH TOOLS, HALF PRICE

Assistance technique et certificat de garantie électronique

www.vevor.com/support

VEVOR[®]

TOUGH TOOLS, HALF PRICE

Technical Support and E-Warranty Certificate www.vevor.com/support

GITTERGARTENWAGEN

TC2024

BENUTZERHANDBUCH

Wir sind weiterhin bestrebt, Ihnen Werkzeuge zu wettbewerbsfähigen Preisen anzubieten.

„Sparen Sie die Hälfte“, „Halber Preis“ oder andere ähnliche Ausdrücke, die wir verwenden, stellen nur eine Schätzung der Ersparnis dar, die Sie beim Kauf bestimmter Werkzeuge bei uns im Vergleich zu den großen Topmarken erzielen können, und decken nicht unbedingt alle von uns angebotenen Werkzeugkategorien ab. Wir möchten Sie freundlich daran erinnern, bei Ihrer Bestellung bei uns sorgfältig zu prüfen, ob Sie im Vergleich zu den großen Topmarken tatsächlich die Hälfte sparen.

VEVOR®

GITTERGARTENWAGEN
TC2024
BENUTZERHANDBUCH

TC2024



Brauchen Sie Hilfe? Kontaktieren Sie uns!

Have product questions? Need technical support? Please feel free to reach out to us:

Technischer Support und E-Garantie-Zertifikat www.vevor.com/support

Dies ist die Originalanleitung. Bitte lesen Sie alle Anweisungen im Handbuch sorgfältig durch, bevor Sie das Produkt in Betrieb nehmen. Die VEVOR reserves clear interpretation of our user manual. The app's Garantie für das Produkt richtet sich nach dem Produkt, das Sie erhalten haben. Bitte verzeihen Sie uns, dass wir Sie nicht erneut informieren, wenn es neue Technologien oder Software-Updates für unser Produkt gibt.

SICHERHEITSHINWEISE

WARNUNG:

1. Bitte überprüfen Sie, ob der Wagen intakt ist und der Reifendruck vor jedem Gebrauch normal.
2. Die Beförderung von Personen ist unter allen Umständen verboten.
3. Das Verladen von Gegenständen auf unebenem und hügeligem Gelände ist verboten.
4. Überlastung ist strengstens verboten.
5. Fahren Sie nicht zu schnell durch Schlaglöcher

ACHTUNG: Lesen Sie die Anweisungen und Verfahren für einen sicheren Betrieb sorgfältig durch.

MODELL UND PARAMETER

Modell	TC2024
Maximale statische Belastung	1400 Pfund
Reifendruck	25 bis 30 psi
Rahmengröße	1110±10x755±10mm
Räderspezifikation (in)	16*4.00-8 (Durchmesser * Breite-Nabengröße)

KOMPONENTEN



A. Endabschnitte (x2)



B. Seitenteile (x2)



C. Luftbereifte Räder (x4)

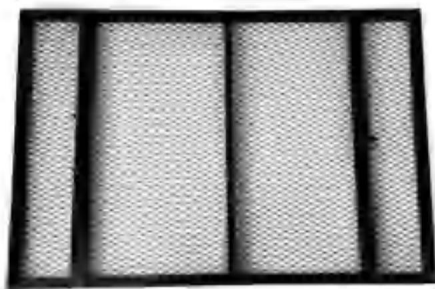

D. Basis (x1)

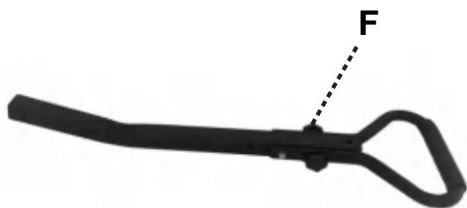

E. Griff (x1)



F. Fünf-Stern-Schraube und Mutter (x1)



G. Griffhalterung (x1)



H. Vorderachse (x1)



I. Hinterachse (x1)



J. Schrauben/Unterlegscheiben/Muttern (x2)



K. Große Nylonmuttern/Unterlegscheiben (M12x2+M18x1)



L. Bolzenmutter/Unterlegscheibe (x1)



M. R-Stifte (x16)



O. Abschnittsverbindungsstücke (x8)



N. Splintstifte (x4)



P. Radscheiben (x4)



F. Gummimatte (x1)

MONTAGE

Schritt 1: Befestigen Sie die Griffhalterung (G) mit den beiden Schrauben/Unterlegscheiben/ Muttern (J) an der Vorderachse (H).

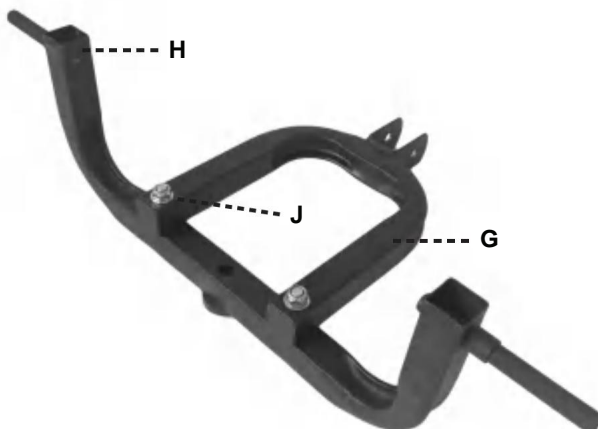

Schritt 2: Nehmen Sie die Basis (D) und drehen Sie sie um, sodass die hervorstehenden Bolzen nach oben zeigen.

K

Setzen Sie beide Achsen (H/I) auf die Bolzen und ziehen Sie sie anschließend mit den beiden großen Nylonmuttern/-scheiben (K) fest, wie gezeigt.

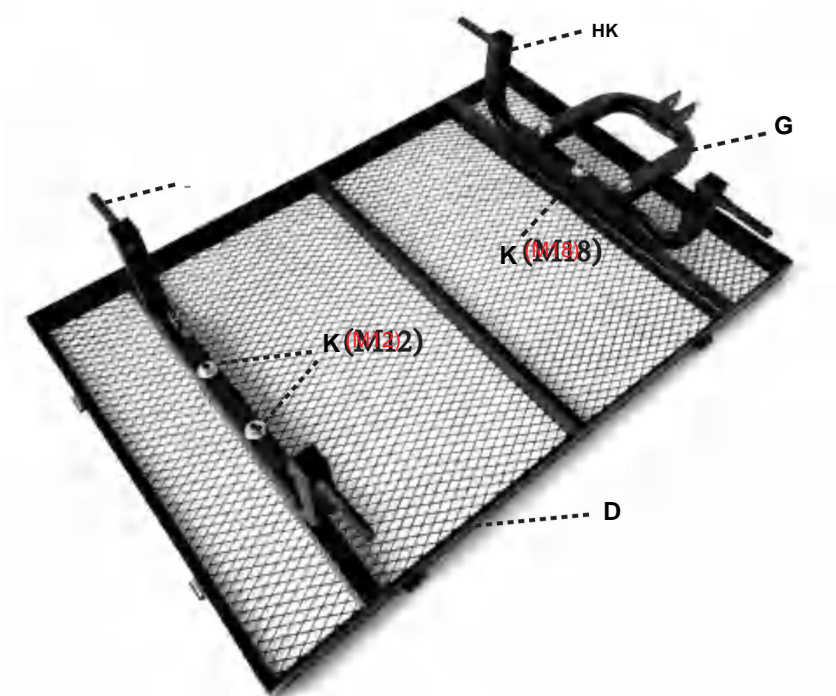

Schritt 3: Befestigen Sie die 4 Lufträder (C) an jedem Ende der montierten Basis, gefolgt von der Radscheibe (P).

Fädeln Sie den Splintstift (N) durch jedes Loch und biegen Sie ihn fest, um ihn an seinem Platz zu befestigen.

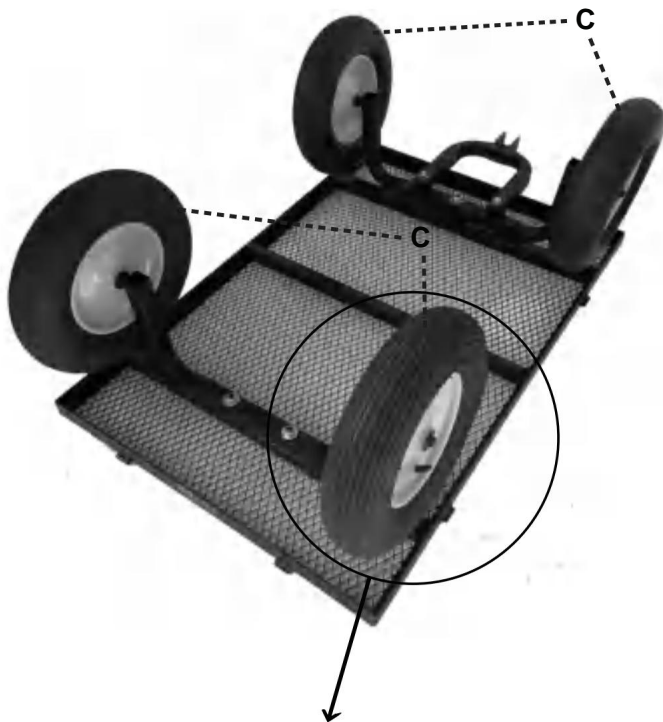

Schritt 4: Entfernen Sie die Schraube/Unterlegscheibe/Mutter (L(f)) vom Kunststoffblock (F).
Richten Sie den Griff (E) und den Kunststoffblock (L) (F) an den Löchern der Griffhalterung (G) aus.

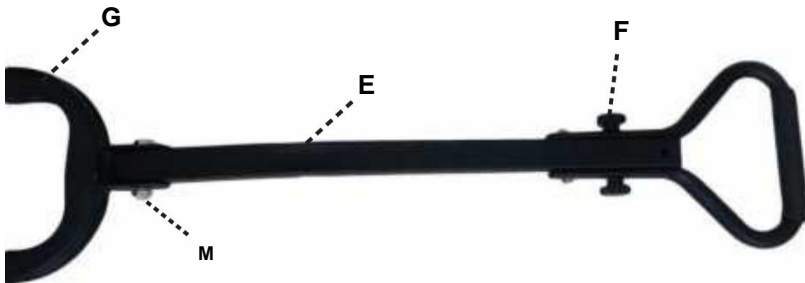
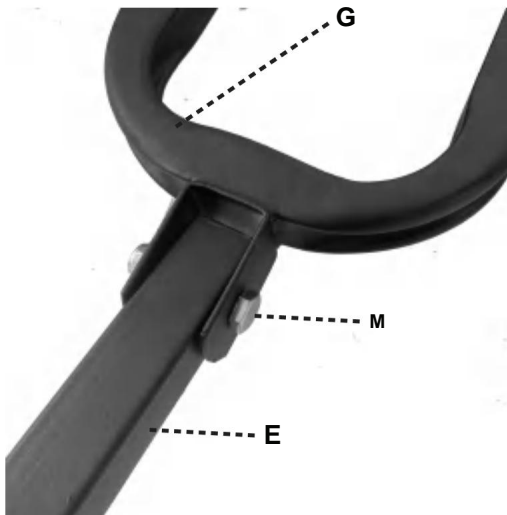

Schritt 5: Stellen Sie den zusammengebauten Wagen auf die Räder, nehmen Sie dann die Seitenteile (B) und die Endteile (A) und befestigen Sie sie mit den R-Stiften (M).

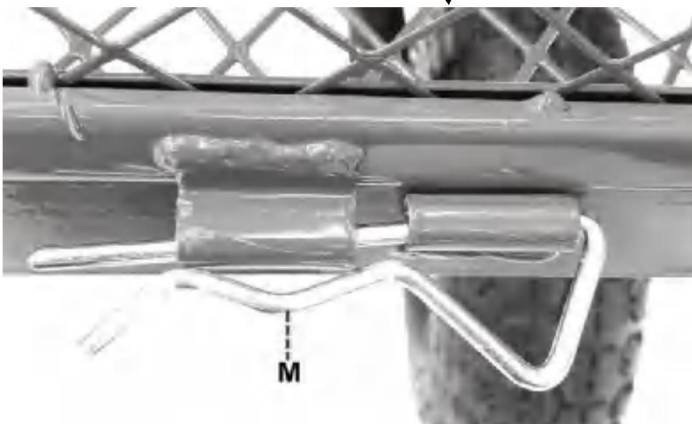
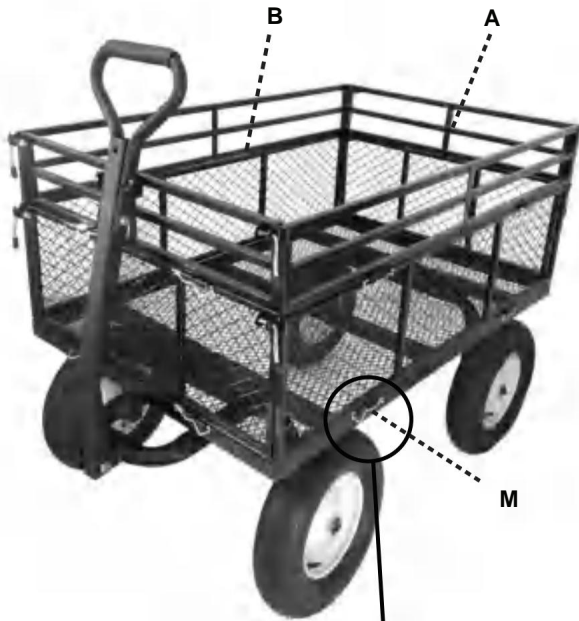

NOTIZ: Ensure the brackets are on the outside of the cart for keeping the sides and ends sitting flush.

HINWEIS: Heben Sie die Verriegelungsgriffe an, um sie an den Schlitzen an den Seitenwänden auszurichten.
Zum Sichern die Verriegelungsgriffe herunterklappen.

Schritt 6: Nach dem Lösen des Trolleygriffs kann dieser auch zum Ziehen und
motor vehicle connection, only rotating the trolley handle upward and fix the
handle on the upper hole with the five-star screen and nut.



Hersteller: Shanghai muxinmuyeyouxiangongsi

Adresse: Shuangchenglu 803nong11hao1602A-1609shi, baoshanqu, Shanghai 200000 CN.

Nach AUS importiert: SIHAO PTY LTD. 1 ROKEVA STREET EASTWOOD NSW 2122 Australien

Importiert in die USA: Sanven Technology Ltd. Suite 250, 9166 Anaheim Place, Rancho Cucamonga, CA 91730



E-CrossStu GmbH
Mainzer Landstr.69, 60329 Frankfurt am Main.



YH CONSULTING LIMITED.
C/O YH Consulting Limited Office 147, Centurion House,
London Road, Staines-upon-Thames, Surrey, TW18 4AX

VEVOR[®]

TOUGH TOOLS, HALF PRICE

Technischer Support und E-Garantie-Zertifikat

www.vevor.com/support