

VEVOR[®]

TOUGH TOOLS, HALF PRICE

Technical Support and E-Warranty Certificate www.vevor.com/support

BEE HIVE

MODEL: FX1+1

We continue to be committed to provide you tools with competitive price.

"Save Half", "Half Price" or any other similar expressions used by us only represents an estimate of savings you might benefit from buying certain tools with us compared to the major top brands and does not necessarily mean to cover all categories of tools offered by us. You are kindly reminded to verify carefully when you are placing an order with us if you are actually saving half in comparison with the top major brands.

VEVOR®

TOUGH TOOLS, HALF PRICE

BEE HIVE

MODEL: FX1+1



NEED HELP? CONTACT US!

Have product questions? Need technical support? Please feel free to contact us:

Technical Support and E-Warranty Certificate
www.vevor.com/support

This is the original instruction, please read all manual instructions carefully before operating. VEVOR reserves a clear interpretation of our user manual. The appearance of the product shall be subject to the product you received. Please forgive us that we won't inform you again if there are any technology or software updates on our product.



Warning-To reduce the risk of injury, user must read instructions manual carefully.

INSTALLATION NOTES

NOTES:

1. Try to choose hard ground for installation.
2. Prepare installation tools in advance (Rubber hammer and wood).
3. Carefully read this installation manual and confirm the quantity of accessories according to the list.

MODEL AND PARAMETERS

Model	FX1+1
Product size	562*462*515mm
Cabinet material	Fir wood
Surface treatment	Wax boiling process

COMPONENTS

 A1 240 Coaming 1(x2)	 B1-1 B1-2 B1 240 Coaming 2(x2)
 A2 170 Coaming 1(x2)	 B2-1 B2-2 B2 170 Coaming 2(x2)



C 170/240 Main frame bar 1(×20)



D 170/240 Main frame bar 2(×20)



E1 240 Frame bar (×20)



E2 170 Frame bar (×20)



F1 240 Foundation sheet (×10)



F2 170 Foundation sheet (×10)



G Handle (×2)



H Screw M4x30 (×2)



I-1 **I-2**
I Window pane (×2)



J Self-tapping screw M4x20 (×4)



K Small plank (×4)



L Top Cover (×1)



M Inner Cover (×1)



N Bottom Board(×1)

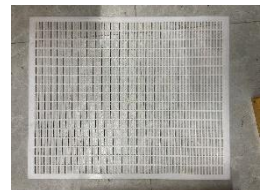

O Queen Excluder (×1)



P Entrance Reducer(x1)



Q iron nails (x80)



R Self-tapping screw
M3x12 (x8)



S Acrylic panel window (x2)

ASSEMBLY

240 BOX

1. Installation of 240 box

Step 1: Take two pieces of **A1** and two pieces of **B1(B1-1&B1-2)** respectively, and connect them with a rubber hammer (note that it is not allowed to knock them directly, but put a board or cardboard on them and knock them in evenly).

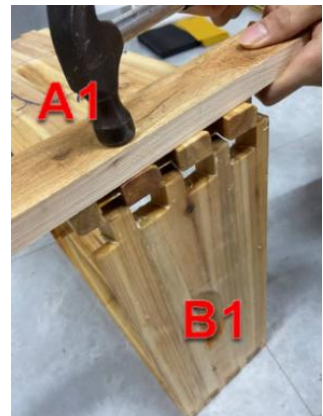
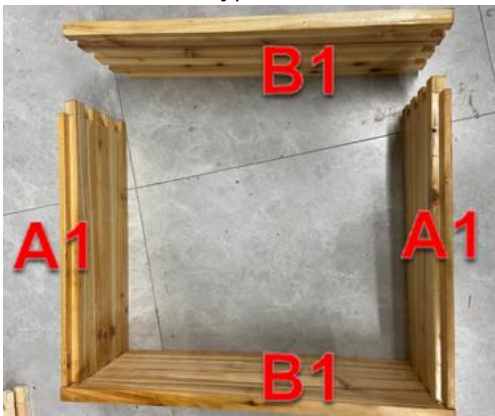

2. Installation of 240 frame

Step 1: Take 2 pieces of **E1** and 1 piece of **C**, insert them into the card slot to connect them, then take 1 piece of **F1** and insert it into the slot, and finally take 1 piece of **D** and insert it into the slot to complete a set of 170 frames.

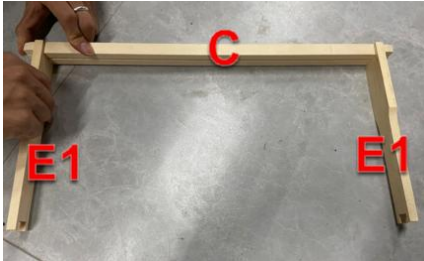

Step 2: Connect with 4 pieces of **Q** at a/b/c/d 4 positions.

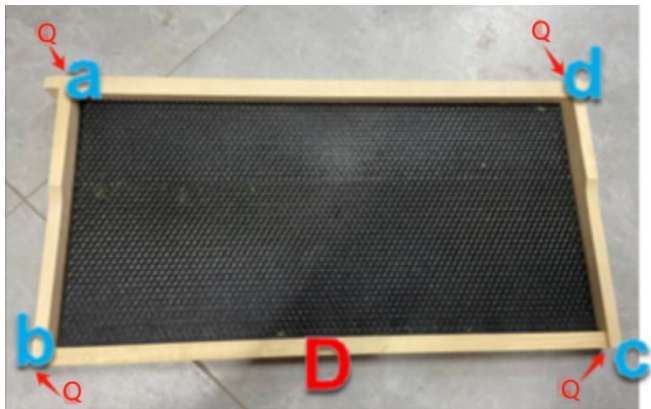

3. Installation of the window

Step 1: Take **G**, **H** and **I-1** to assemble the cover plate.



Step 2: Take **S** and Peel off the film from the corners, then Take **S** and **R** to assemble the Coaming.



Step 3: Take **J** and **K** to assemble the window pressing plates on both sides and put 10 sets of foundations and frames into the box.



170 BOX

4. Installation of 170 box

Step 1: Take two pieces of **A2** and two pieces of **B2(B2-1&B2-2)** respectively, and connect them with a rubber hammer (note that it is not allowed to knock them directly, but put a board or cardboard on them and knock them in evenly).

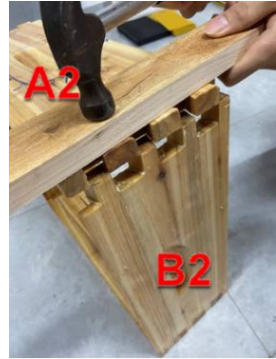
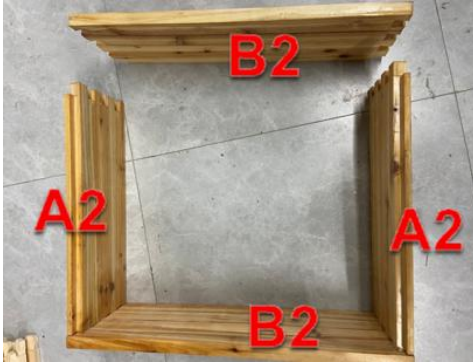

5. Installation of 170 frame

Step 1: Take 2 pieces of **E2** and 1 piece of **C**, insert them into the card slot to connect them, then take 1 piece of **F2** and insert it into the slot, and finally take 1 piece of **D** and insert it into the slot to complete a set of 170 frames.

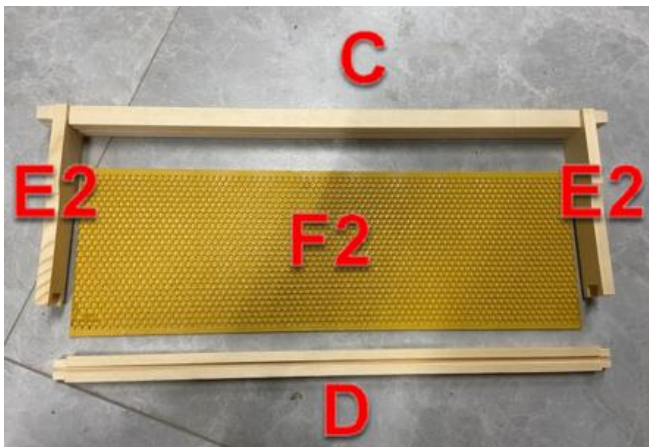

Step 2: Connect with 4 pieces of **Q** at a/b/c/d 4 positions.



6. Installation of the window

Step 1: Take **G**, **H** and **I-2** to assemble the cover plate.



Step 2: Take **N** and Peel off the film from the corners, then Take **N** and **M** to assemble the Coaming.





Step 3: Take J and K to assemble the window pressing plates on both sides and put 10 sets of foundations and frames into the box.



Finally, please assemble according to the following figure:

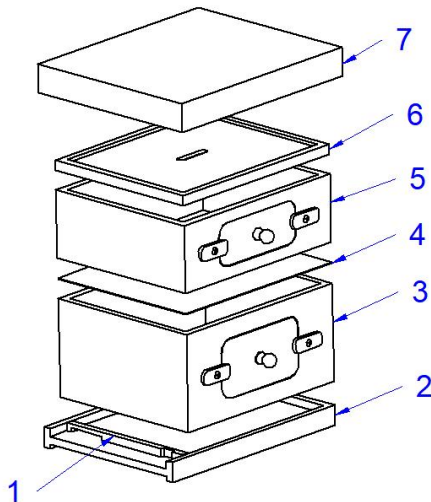

- 1. Entrance Reducer
- 2. Bottom Board
- 3. 240 Box
- 4. Queen Excluder
- 5. 170 Box
- 6. Inner Cover
- 7. Top Cover

MAINTENANCE

1. Please use beeswax regularly for maintenance.
2. Close the bee window in cold, rainy, and windy weather.

Manufacturer: Shanghaimuxinmuyeyouxiangongsi

Address: Baoshanqu Shuangchenglu 803long 11hao 1602A-1609shi

Shanghai

Imported to AUS: SIHAO PTY LTD, 1 ROKEVA STREETEASTWOOD
NSW 2122 Australia

Imported to USA: Sanven Technology Ltd., Suite 250, 9166 Anaheim
Place, Rancho Cucamonga, CA 91730



SHUNSHUN GmbH
Römeräcker 9 Z2021,76351
Linkenheim-Hochstetten, Germany
euvertreter@gmail.com
+49 1727041930



Pooledas Group Ltd
Unit 5 Albert Edward House, The
Pavilions Preston, United Kingdom
pooledas123@gmail.com
01772418127

Made In China

VEVOR[®]
TOUGH TOOLS, HALF PRICE

Technical Support and E-Warranty Certificate
www.vevor.com/support

VEVOR[®]

TOUGH TOOLS, HALF PRICE

Técnico Certificado de soporte y garantía electrónica www.vevor.com/support

COLMENA

MODELO: FX1+1

We continue to be committed to provide you tools with competitive price.

"Save Half", "Half Price" or any other similar expressions used by us only represents an estimate of savings you might benefit from buying certain tools with us compared to the major top brands and does not necessarily mean to cover all categories of tools offered by us. You are kindly reminded to verify carefully when you are placing an order with us if you are actually saving half in comparison with the top major brands.

VEVOR®

TOUGH TOOLS, HALF PRICE

BEE HIVE

MODELO: FX 1+1



NEED HELP? CONTACT US!

Have product questions? Need technical support? Please feel free to contact us:

Technical Support and E-Warranty Certificate
www.vevor.com/support

This is the original instruction, please read all manual instructions carefully before operating. VEVOR reserves a clear interpretation of our user manual. The appearance of the product shall be subject to the product you received. Please forgive us that we won't inform you again if there are any technology or software updates on our product.



Advertencia: para reducir el riesgo de lesiones, el usuario debe leer atentamente el manual de instrucciones.

INSTALLATION NOTES

NOTAS :













2. Intente elegir un terreno duro para la instalación.
2. Prepare las herramientas de instalación con anticipación (martillo de goma y madera) .
3. Lea atentamente este manual de instalación y confirme la cantidad de accesorios según la lista.







MODEL AND PARAMETERS

Modelo	FX1+1
Tamaño del producto	562*462*515mm
Material del gabinete	Madera de abeto
Tratamiento de superficies	Proceso de ebullición de cera

COMPONENTS

 A1 240 Llegando 1(× 2)	 B 1-1 B 1-2 B 1 24 0 Brazona 2(× 2)
 B 2-1	 B 2-1 B 2-2

un 2 17 0 Llegando 1(× 2)	B2 170 Brazola 2(× 2)	
 <p>C 170/240 Principal barra del marco 1(×2 0)</p>	 <p>D 170/240 Barra del marco principal 2 (×20)</p>	 <p>mi 1 24 0 Barra del marco (× 20)</p>
 <p>E2 170 Barra del marco (× 20)</p>	 <p>F1 240 Hoja de cimentación (×10)</p>	 <p>F2 170 Hoja de cimentación (×10)</p>
 <p>G (×2)</p>	 <p>Tornillo H M4x30 (×2)</p>	 <p>yo -1 yo -2 I Panel de ventana (×2)</p>
 <p>J Tornillo autorroscante M4x20 (×4)</p>	 <p>K Tablón pequeño (×4)</p>	 <p>Cubierta superior L (× 1)</p>

 <p>M Cubierta interior (× 1)</p>	 <p>N Tablero inferior (x1)</p>	 <p>Oh reina excluyente (x1)</p>
 <p>P Reductor de entrada(x1)</p>	 <p>Clavos de hierro Q (x80)</p>	 <p>R Tornillo autorroscante M3x12 (×8)</p>
 <p>S Ventana de panel acrílico (x2)</p>		

ASSEMBLY

CAJA 240

7. Instalación de caja 24 0

Paso 1: Tome dos piezas de **A1** y dos piezas de **B1 (B1-1 y B1-2)** respectivamente y conéctelas con un martillo de goma (tenga en cuenta que no está permitido golpearlas directamente, pero coloque una tabla o cartón sobre ellas y golpéelos uniformemente).

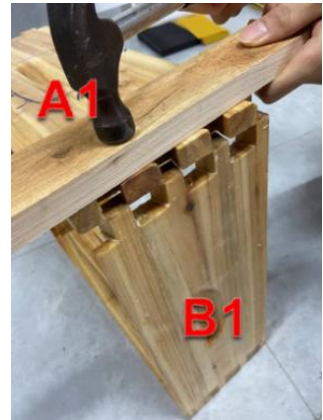
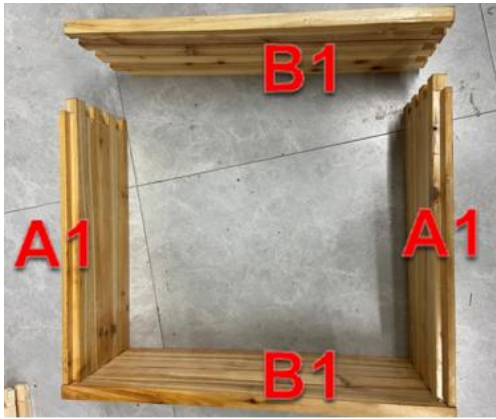

8. Instalación de marco 24 0 .

Paso 1: Tome 2 piezas de **E1** y 1 pieza de **C** , insértelas en la ranura para tarjetas para conectarlas, luego tome 1 pieza de **F1** e insértela en la ranura, y finalmente tome 1 pieza de **D** e insértela en la ranura. para completar un conjunto de 170 cuadros.

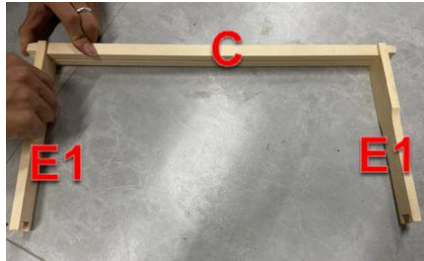

Paso 2: Conecte con 4 piezas de **Q** en las 4 posiciones a/b/c/d.

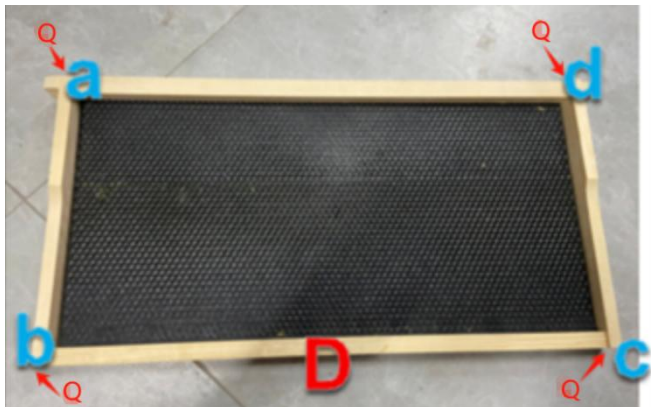

9. Instalación de la ventana

Paso 1: Tome G , H e I-1 para ensamblar la placa de cubierta.



Paso 2: Tome S y retire la película de las esquinas, luego tome S y R para ensamblar la brazola.





Paso 3: Tome **J** y **K** para ensamblar las placas de presión de la ventana en ambos lados y coloque 10 juegos de cimientos y marcos en la caja.



17 0 CAJA

10. Instalación de caja de 170

Paso 1: Tome dos piezas de **A2** y dos piezas de **B2 (B2-1 y B2-2)** respectivamente y conéctelas con un martillo de goma (tenga en cuenta que no está permitido golpearlas directamente, pero coloque una tabla o cartón sobre ellas y golpéelos uniformemente).

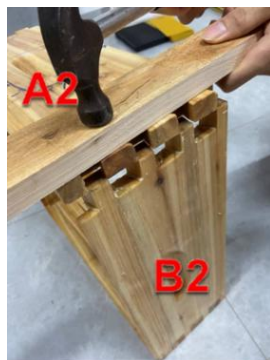
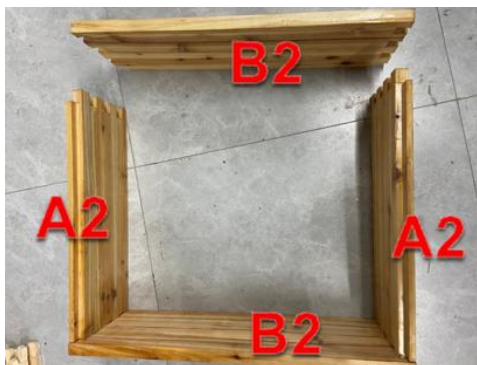

11. marco 170.

Paso 1: Tome 2 piezas de **E2** y 1 pieza de **C** , insértelas en la ranura para tarjetas para conectarlas, luego tome 1 pieza de **F2** e insértela en la ranura, y finalmente tome 1 pieza de **D** e insértela en la ranura. para completar un conjunto de 170 cuadros.

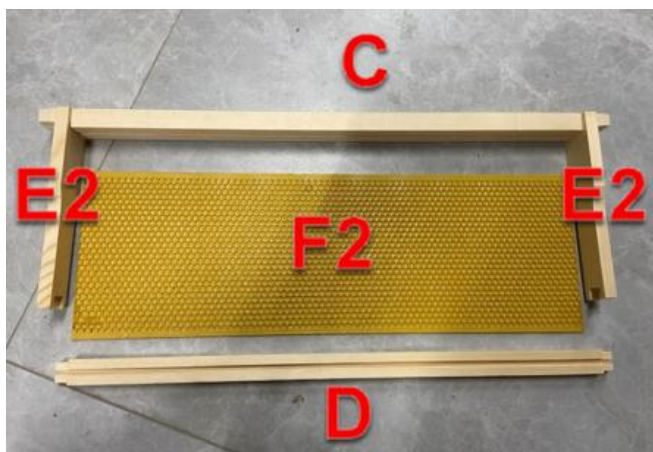

Paso 2: Conecte con 4 piezas de **Q** en las 4 posiciones a/b/c/d.

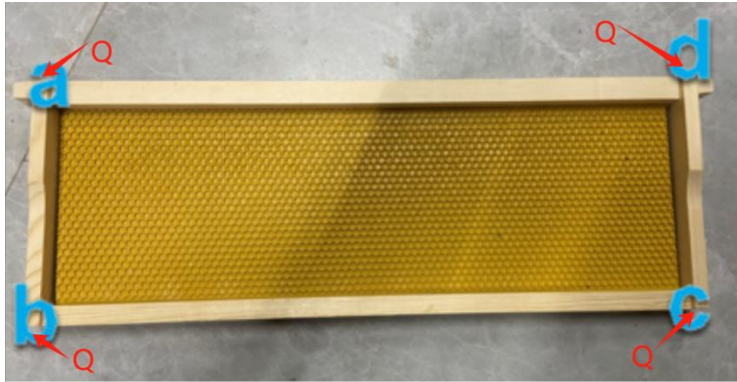

12. Instalación de la ventana

Paso 1: Tome G , H e I-2 para ensamblar la placa de cubierta.



Paso 2: Tome N y retire la película de las esquinas, luego tome N y M para ensamblar la brazola.





Paso 3: Tome J y K para ensamblar las placas de presión de la ventana en ambos lados y coloque 10 juegos de cimientos y marcos en la caja.

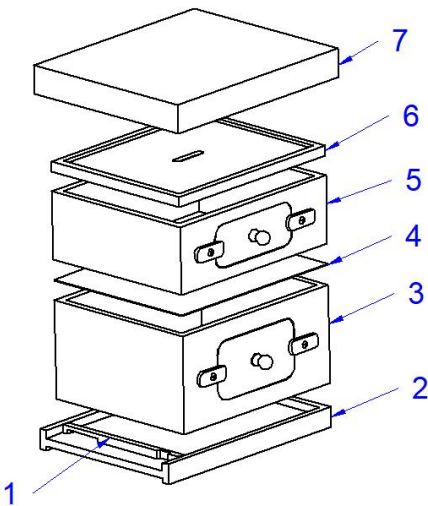

Finalmente, monte de acuerdo con la siguiente figura:

- 1.Reductor de entrada
2. Tablero inferior
- 3.240 Caja

- 4.Excluidor de reina
- 5.170 Caja
- 6.Cubierta interior
- 7.Cubierta superior

MAINTENANCE

1. Utilice cera de abejas con regularidad para el mantenimiento.
2. Cierra la ventana de las abejas en climas fríos, lluviosos y ventosos.

Fabricante: Shanghaimuxinmuyeyouxiangongsi

Dirección: Baoshanqu Shuangchenglu 803long 11hao 1602A-1609shi
Shanghai

Importado a AUS: SIHAO PTY LTD, 1 ROKEVA STREETEASTWOOD
NSW 2122 Australia

Importado a EE. UU.: Sanven Technology Ltd., Suite 250, 9166 Anaheim
Place, Rancho Cucamonga, CA 91730



SHUNSHUN GmbH
Römeräcker 9 Z2021,76351
Linkenheim-Hochstetten, Germany
euvertreter@gmail.com
+49 1727041930



Pooledas Group Ltd
Unit 5 Albert Edward House, The
Pavilions Preston, United Kingdom
pooledas123@gmail.com
01772418127

Hecho en china

VEVOR[®]
TOUGH TOOLS, HALF PRICE

Técnico Certificado de soporte y garantía electrónica
www.vevor.com/support

VEVOR[®]

TOUGH TOOLS, HALF PRICE

Teknisk Support och e-garanticertifikat www.vevor.com/support

BEE HIVE

MODELL: FX1+1

We continue to be committed to provide you tools with competitive price.

"Save Half", "Half Price" or any other similar expressions used by us only represents an estimate of savings you might benefit from buying certain tools with us compared to the major top brands and does not necessarily mean to cover all categories of tools offered by us. You are kindly reminded to verify carefully when you are placing an order with us if you are actually saving half in comparison with the top major brands.

VEVOR®

TOUGH TOOLS, HALF PRICE

BEE HIVE

MODELL: FX 1+1



NEED HELP? CONTACT US!

Have product questions? Need technical support? Please feel free to contact us:

Technical Support and E-Warranty Certificate
www.vevor.com/support

This is the original instruction, please read all manual instructions carefully before operating. VEVOR reserves a clear interpretation of our user manual. The appearance of the product shall be subject to the product you received. Please forgive us that we won't inform you again if there are any technology or software updates on our product.



Varning - För att minska risken för skada måste användaren läsa instruktionerna noggrant.

INSTALLATION NOTES

ANMÄRKNINGAR :

3. Försök att välja hård mark för installation.
2. Förbered installationsverktyg i förväg (gummihammare och trä) .
3. Läs denna installationsmanual noggrant och bekräfta mängden tillbehör enligt listan.

MODEL AND PARAMETERS

Modell	FX1+1
Produktstorlek	562*462*515 mm
Skåpsmaterial	Gran trä
Ytbehandling	Vaxkokningsprocess

COMPONENTS

 A1 240 C oaming 1(x 2)	 B 1-1 B 1-2 B 1 24 0 Coaming 2(x 2)
 A 2 17 0 C oaming 1(x 2)	 B 2-1 B 2-2 B2 170 Coaming 2(x 2)



C 170/240 Main
ramstapel 1(×2 0)



D 170/240
Huvudramstång 2 (×20)



E 1 24 0 ramfält (×
20)



E2 170 ramstång (× 20)



F1 240 Grundblad (×10)



F2 170 Grundblad
(×10)



G- handtag (×2)



H- skruv M4x30 (×2)



Jag -1 **Jag**
-2
I Fönsterfönster (×2)









J Självgående skruv
M4x20 (×4)



K Liten plank (×4)

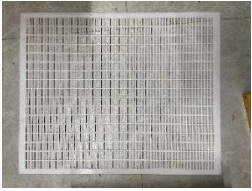

L Topplöck (× 1)

 <p>M Inre lock (× 1)</p>	 <p>N Bottenbräda (x1)</p>	 <p>O Queen Excluder (x1)</p>
 <p>P Entréreducerare (x1)</p>	 <p>Q järnspik (x80)</p>	 <p>R Självgående skruv M3x12 (×8)</p>
 <p>S Akrylpanelfönster (x2)</p>		

ASSEMBLY

240 BOX

13. Installation av 240 box

Steg 1: Ta två bitar av **A1** respektive två bitar av **B1(B1-1&B1-2)** och koppla ihop dem med en gummihammare (observera att det inte är tillåtet att slå dem direkt, utan lägg en tavla eller kartong på dem och slå in dem jämnt).

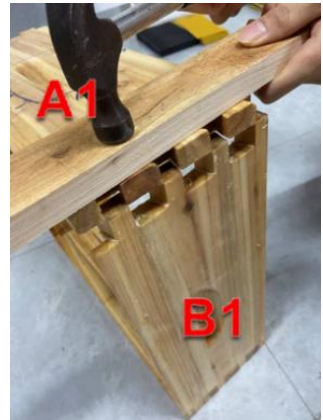
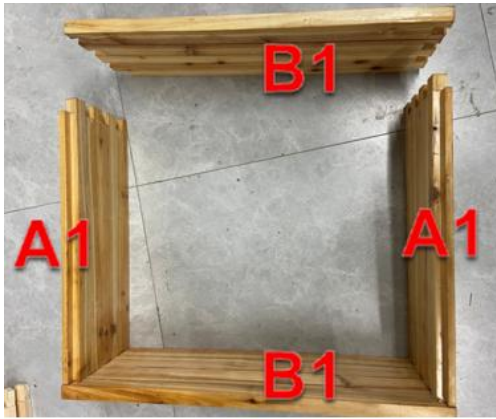

14. Installation av 24 0 ram

Steg 1: Ta 2 bitar av **E1** och 1 bit **C** , sätt in dem i kortfacket för att ansluta dem, ta sedan 1 bit **F1** och sätt in den i kortplatsen, och slutligen ta 1 bit **D** och sätt in den i kortplatsen för att slutföra en uppsättning med 170 bildrutor.

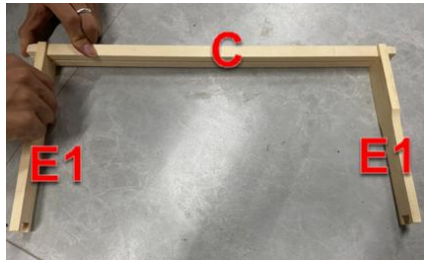

Steg 2: Anslut med 4 bitar av **Q** i a/b/c/d 4 positioner.

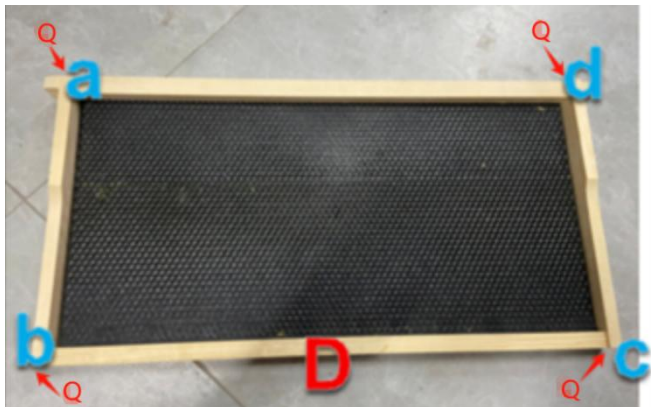

15. Installation av fönstret

Steg 1: Ta G , H och I-1 för att montera täckplattan.



Steg 2: Ta S och dra av filmen från hörnen, ta sedan S och R för att montera Coaming.





Steg 3: Ta **J** och **K** för att montera fönsterpressplattorna på båda sidor och lägg 10 uppsättningar fundament och ramar i lådan.



17 0 LÅDA

16. Installation av 170 box

Steg 1: Ta två bitar av **A2** respektive två bitar av **B2(B2-1&B2-2)** och koppla ihop dem med en gummihammare (observera att det inte är tillåtet att slå dem direkt, utan lägg en tavla eller kartong på dem och slå in dem jämnt).

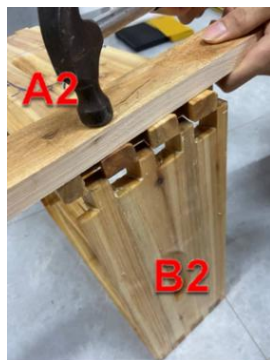
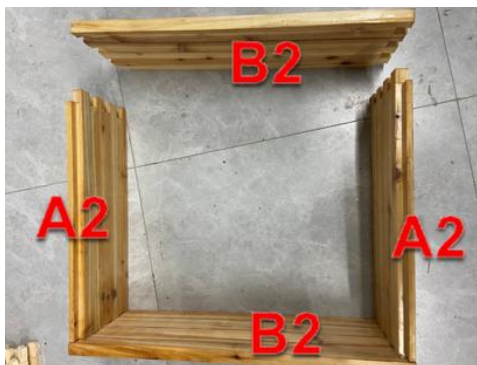

17. Montering av 170 ram

Steg 1: Ta 2 stycken **E2** och 1 stycke **C**, sätt in dem i kortfacket för att ansluta dem, ta sedan 1 stycke **F2** och sätt in det i facket, och slutligen ta 1 stycke **D** och sätt in det i facket för att slutföra en uppsättning med 170 bildrutor.

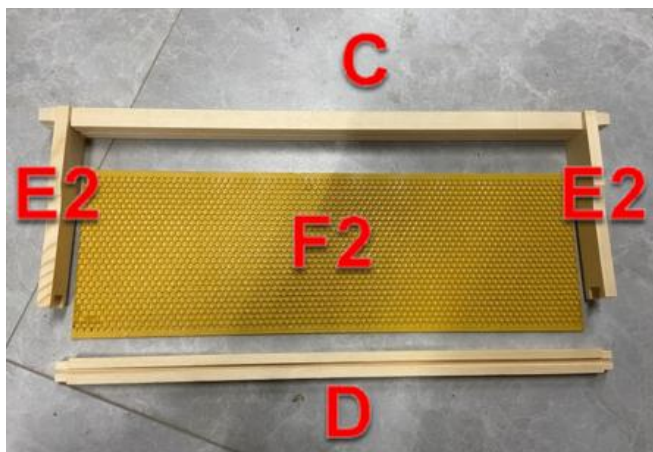

Steg 2: Anslut med 4 bitar av **Q** i a/b/c/d 4 positioner.

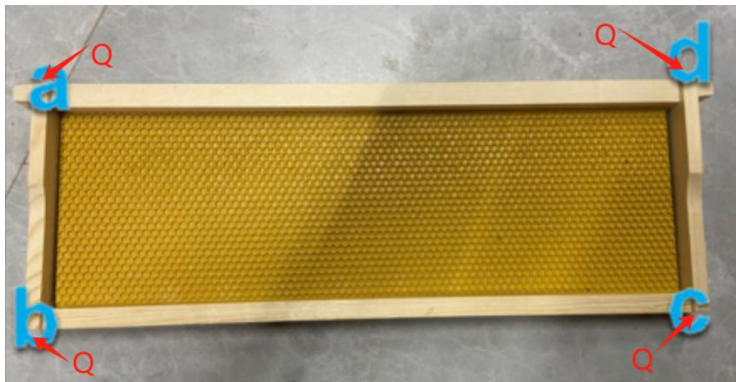

18. Installation av fönstret

Steg 1: Ta **G** , **H** och **I-2** för att montera täckplattan.



Steg 2: Ta **N** och dra bort filmen från hörnen, ta sedan **N** och **M** för att montera ihop kojén.





Steg 3: Ta **J** och **K** för att montera fönsterpressplattorna på båda sidor och lägg 10 uppsättningar fundament och ramar i lådan.

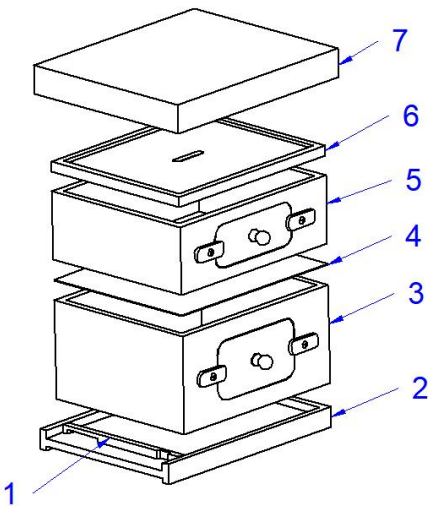

Till sist, montera enligt följande figur:

1. Entréreducerare
2. Bottenbräda
3. 240 kartong
4. Queen Excluder

- 5.170 Box
- 6. Innerskydd
- 7. Topplöck

MAINTENANCE

1. Använd bivax regelbundet för underhåll.
2. Stäng bifönstret i kallt, regnigt och blåsigt väder.

Tillverkare: Shanghaimuxinmuyeyouxiangongsi

Adress: Baoshanqu Shuangchenglu 803long 11hao 1602A-1609shi
Shanghai

Importerad till AUS: SIHAO PTY LTD, 1 ROKEVA STREETEASTWOOD
NSW 2122 Australien

Importerad till USA: Sanven Technology Ltd., Suite 250, 9166 Anaheim
Place, Rancho Cucamonga, CA 91730



SHUNSHUN GmbH
Römeräcker 9 Z2021,76351
Linkenheim-Hochstetten, Germany
euvertreter@gmail.com
+49 1727041930



Pooledas Group Ltd
Unit 5 Albert Edward House, The
Pavilions Preston, United Kingdom
pooledas123@gmail.com
01772418127

Tillverkad i Kina

VEVOR[®]

TOUGH TOOLS, HALF PRICE

Teknisk Support och e-garanticertifikat

www.vevor.com/support

VEVOR[®]

TOUGH TOOLS, HALF PRICE

Technisch Ondersteuning en e-garantiecertificaat www.vevor.com/support

BIJENKORF

MODEL: FX1+1

We continue to be committed to provide you tools with competitive price.

"Save Half", "Half Price" or any other similar expressions used by us only represents an estimate of savings you might benefit from buying certain tools with us compared to the major top brands and does not necessarily mean to cover all categories of tools offered by us. You are kindly reminded to verify carefully when you are placing an order with us if you are actually saving half in comparison with the top major brands.

VEVOR®

TOUGH TOOLS, HALF PRICE

BEE HIVE

MODEL: FX 1+1



NEED HELP? CONTACT US!

Have product questions? Need technical support? Please feel free to contact us:

Technical Support and E-Warranty Certificate
www.vevor.com/support

This is the original instruction, please read all manual instructions carefully before operating. VEVOR reserves a clear interpretation of our user manual. The appearance of the product shall be subject to the product you received. Please forgive us that we won't inform you again if there are any technology or software updates on our product.



Waarschuwing-Om het risico op letsel te verminderen, moet de gebruiker de handleiding zorgvuldig lezen.

INSTALLATION NOTES



OPMERKINGEN :

4. Probeer een harde ondergrond te kiezen voor installatie.
2. Bereid vooraf het installatiegereedschap voor (rubberhamer en hout) .
3. Lees deze installatiehandleiding aandachtig door en bevestig het aantal accessoires volgens de lijst.





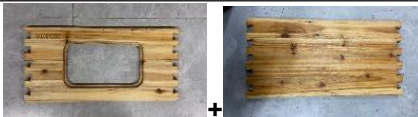

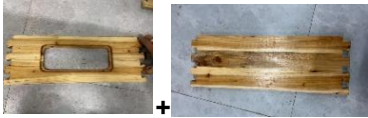
MODEL AND PARAMETERS

Model	FX1+1
Product grootte	562*462*515mm
Materiaal kast	Sparrenhout
Oppervlakte behandeling	Was kookproces

COMPONENTS

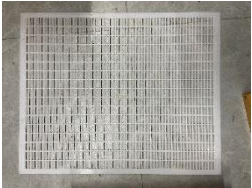
 A1 240 C oamen 1(x 2)	 B1-1B1-2 _ _ _ B1 _ 24 0 Bekleding 2(x 2)
 Een 2 17 0 C oamen 1(x	 B2-1B2-2 _ _ _ B2 170 Bekleding 2(x 2)

2)		
<p>C 170/240 Hoofd framebalk 1(×2 0)</p>	<p>D 170/240 Hoofdframebalk 2 (×20)</p>	<p>E 1 24 0 Framebalk (× 20)</p>
<p>E2 170 Framebalk (× 20)</p>	<p>F1 240 Funderingsplaat (×10)</p>	<p>F2 170 Funderingsplaat (×10)</p>
<p>G- handvat (×2)</p>	<p>H Schroef M4x30 (×2)</p>	<p>ik -1 ik -2 I Ruit (×2)</p>
<p>J Zelftappende schroef M4x20 (×4)</p>	<p>K Kleine plank (×4)</p>	<p>L Bovenklep (× 1)</p>

 <p>M Binnenafdekking (× 1)</p>	 <p>N Bodemplaat (x1)</p>	 <p>O Koningin Excluder (x1)</p>
 <p>P Ingangsverkleiner(x1)</p>	 <p>Q ijzeren spijkers (x80)</p>	 <p>R Zelftappende schroef M3x12 (×8)</p>
 <p>S Acrylpaneelvenster (x2)</p>		

ASSEMBLY

240 DOOS

19. Installatie van 24 0-doos

Stap 1: Neem respectievelijk twee stukken **A1** en twee stukken **B1 (B1-1&B1-2)** , en verbind ze met een rubberen hamer (let op: het is niet toegestaan om er direct op te kloppen, maar leg er een plank of karton op en klop ze er gelijkmatig in).

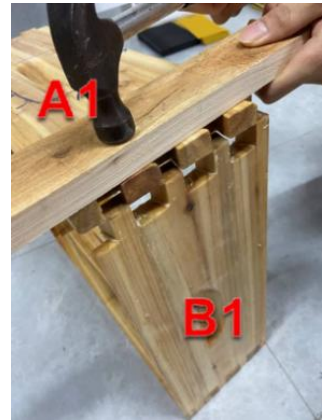
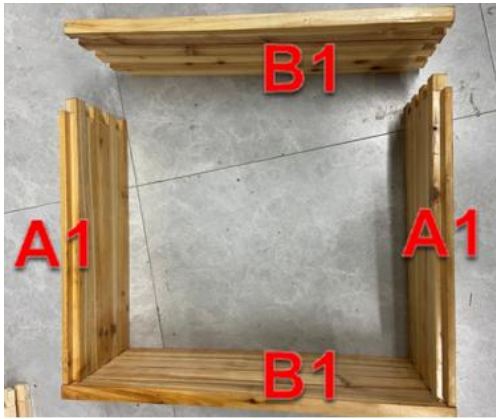

20. Installatie van 24 0 -frame

Stap 1: Neem 2 stukjes **E1** en 1 stuk **C** , steek ze in de kaartsleuf om ze met elkaar te verbinden, neem dan 1 stuk **F1** en plaats dit in de sleuf, en neem ten slotte 1 stuk **D** en steek het in de sleuf om een set van 170 frames te voltooien.

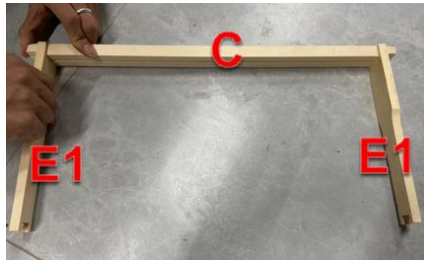

Stap 2: Verbind met 4 stuks **Q** op a/b/c/d 4 posities.

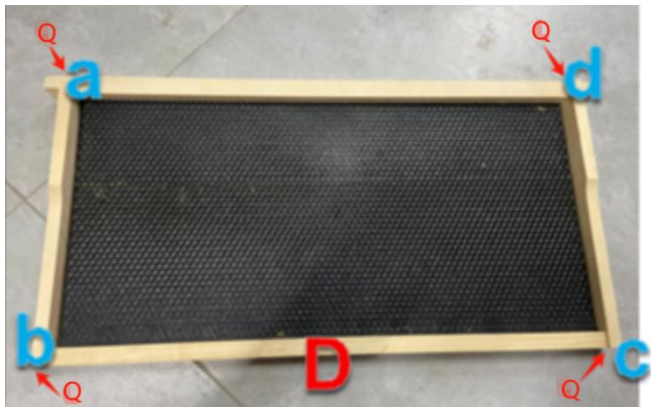

21. Installatie van het raam

Stap 1: Neem **G** , **H** en **I-1** om de afdekplaat te monteren.



Stap 2: Neem **S** en verwijder de film uit de hoeken, neem vervolgens **S** en **R** om de Coaming te monteren.





Stap 3: Neem **J** en **K** om de raamaandrukplaten aan beide zijden te monteren en plaats 10 sets funderingen en kozijnen in de doos.



17 0 DOOS

22. Installatie van 170 doos

Stap 1: Neem respectievelijk twee stukken **A2** en twee stukken **B2** (**B2-1&B2-2**) en verbind ze met een rubberen hamer (let op: het is niet toegestaan om er direct op te kloppen, maar leg er een plank of karton op en klop ze er gelijkmatig in).

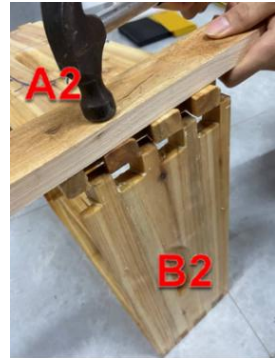
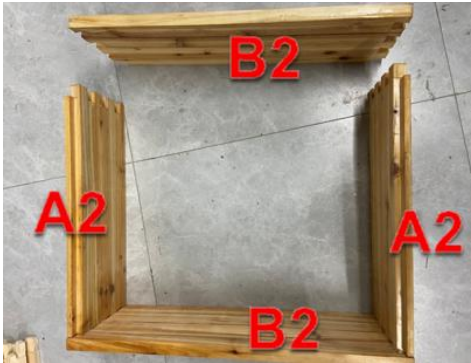

23. Installatie van 170- frame

Stap 1: Neem 2 stukjes **E2** en 1 stuk **C** , steek ze in de kaartsleuf om ze met elkaar te verbinden, neem dan 1 stuk **F2** en plaats dit in de sleuf, en neem ten slotte 1 stuk **D** en steek het in de sleuf om een set van 170 frames te voltooien.

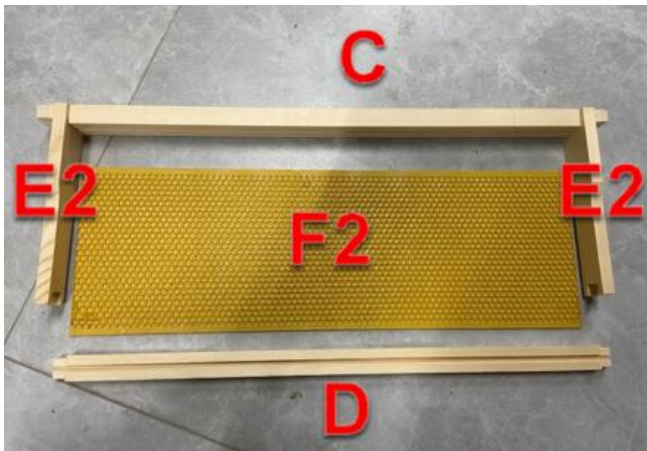

Stap 2: Verbind met 4 stuks **Q** op a/b/c/d 4 posities.

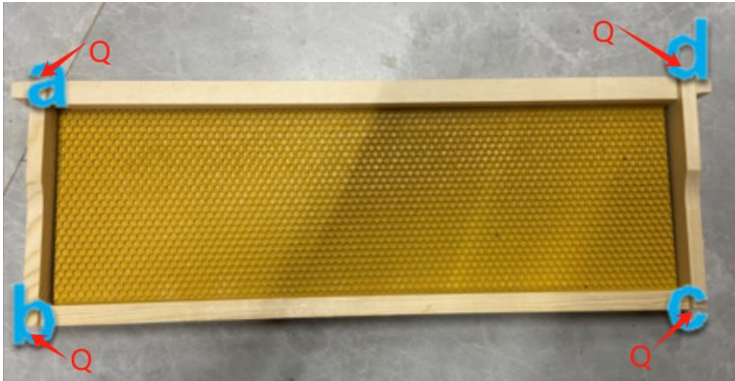

24. Installatie van het raam

Stap 1: Neem **G** , **H** en **I-2** om de afdekplaat te monteren.



Stap 2: Neem **N** en verwijder de film uit de hoeken, neem vervolgens **N** en **M** om de Coaming te monteren.





Stap 3: Neem J en K om de raamaandrukplaten aan beide zijden te monteren en plaats 10 sets funderingen en kozijnen in de doos.

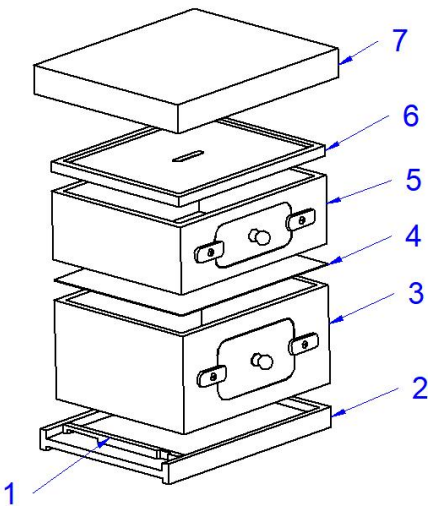

Monteer ten slotte volgens de volgende afbeelding:

1. Ingangsverkleiner
2. Onderplaat
3. 240 doos
4. Koningin Excluder

- 5.170 Doos
- 6. Binnenkap
- 7. Bovenklep

MAINTENANCE

1. Gebruik regelmatig bijenwas voor onderhoud.
2. Sluit het bijenraam bij koud, regenachtig en winderig weer.

Fabrikant: Shanghaimuxinmuyeyouxiangongsi

Adres: Baoshanqu Shuangchenglu 803long 11hao 1602A-1609shi
Shanghai

Geïmporteerd naar AUS: SIHAO PTY LTD, 1 ROKEVA
STREETEASTWOOD NSW 2122 Australië

Geïmporteerd naar de VS: Sanven Technology Ltd., Suite 250, 9166
Anaheim Place, Rancho Cucamonga, CA 91730



SHUNSHUN GmbH
Römeräcker 9 Z2021,76351
Linkenheim-Hochstetten, Germany
euvertreter@gmail.com
+49 1727041930



Pooledas Group Ltd
Unit 5 Albert Edward House, The
Pavilions Preston, United Kingdom
pooledas123@gmail.com
01772418127

Gemaakt in China

VEVOR[®]

TOUGH TOOLS, HALF PRICE

Technisch Ondersteuning en e-garantiecertificaat

www.vevor.com/support

VEVOR[®]

TOUGH TOOLS, HALF PRICE

Technique Assistance et certificat de garantie électronique

www.vevor.com/support

RUCHE D'ABEILLES

MODÈLE : FX1+1

We continue to be committed to provide you tools with competitive price.

"Save Half", "Half Price" or any other similar expressions used by us only represents an estimate of savings you might benefit from buying certain tools with us compared to the major top brands and does not necessarily mean to cover all categories of tools offered by us. You are kindly reminded to verify carefully when you are placing an order with us if you are actually saving half in comparison with the top major brands.

VEVOR®

TOUGH TOOLS, HALF PRICE

BEE HIVE

MODÈLE : FX1 +1



NEED HELP? CONTACT US!

Have product questions? Need technical support? Please feel free to contact us:

Technical Support and E-Warranty Certificate
www.vevor.com/support

This is the original instruction, please read all manual instructions carefully before operating. VEVOR reserves a clear interpretation of our user manual. The appearance of the product shall be subject to the product you received. Please forgive us that we won't inform you again if there are any technology or software updates on our product.



Avertissement : Pour réduire le risque de blessure, l'utilisateur doit lire attentivement le manuel d'instructions.

INSTALLATION NOTES

REMARQUES :











5. Essayez de choisir un sol dur pour l'installation.
2. Préparez les outils d'installation à l'avance (marteau en caoutchouc et bois) .
3. Lisez attentivement ce manuel d'installation et confirmez la quantité d'accessoires selon la liste.





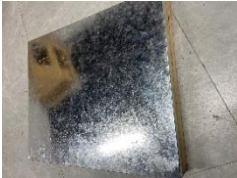

MODEL AND PARAMETERS

Modèle	FX1+1
Taille du produit	562*462*515mm
Matériau du meuble	Bois de sapin
Traitement de surface	Processus d'ébullition de la cire

COMPONENTS

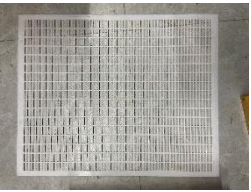
 A1 240 C oaing 1(x 2)	 B1-1B1-2 _ _ _ B1 _ 24 0 Hiloire 2(x 2)
	 B2-1B2-2 _ _ _

Un 2 17 0 C oaing 1(× 2)	B2 170 Hiloire 2(× 2)	
 <p data-bbox="112 319 386 391">C 170/240 Principal barre de cadre 1(×2 0)</p>	 <p data-bbox="442 319 744 391">D 170/240 Barre du cadre principal 2 (×20)</p>	 <p data-bbox="789 319 1013 391">E1 _ 24 0 Barre de cadre (× 20)</p>
 <p data-bbox="95 614 403 686">E2 170 Barre de cadre (× 20)</p>	 <p data-bbox="448 638 739 710">F1 240 Feuille de fondation (×10)</p>	 <p data-bbox="812 614 996 686">F2 170 Feuille de fondation (×10)</p>
 <p data-bbox="207 925 285 965">G (×2)</p>	 <p data-bbox="487 925 700 965">Vis H M4x30 (×2)</p>	 <p data-bbox="789 885 1019 1005">Je -1 Je -2 I Volet de fenêtre (×2)</p>
 <p data-bbox="117 1204 375 1276">J Vis autotaraudeuse M4x20 (×4)</p>	 <p data-bbox="464 1236 722 1276">K Petite planche (×4)</p>	 <p data-bbox="778 1220 1030 1292">L Capot supérieur (× 1)</p>

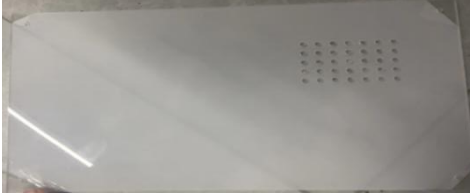
 <p>Couvercle intérieur M (x1)</p>	 <p>N panneau inférieur (x1)</p>	 <p>Ô reine exclue (x1)</p>
 <p>P (x1)</p>	 <p>Clous en fer Q (x80)</p>	 <p>R Vis autotaraudeuse M3x12 (x8)</p>
 <p>S Fenêtre panneau acrylique (x2)</p>		

ASSEMBLY

240 BOÎTE

25. Installation d' une box 24 0

Étape 1 : Prenez respectivement deux morceaux de **A1** et deux morceaux de **B1 (B1-1 et B1-2)** et reliez-les avec un marteau en caoutchouc (notez qu'il n'est pas permis de les frapper directement, mais placez une planche ou un carton dessus et frappez-les uniformément).

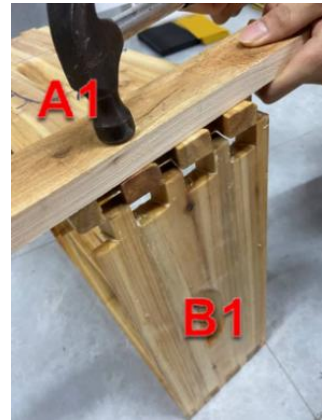
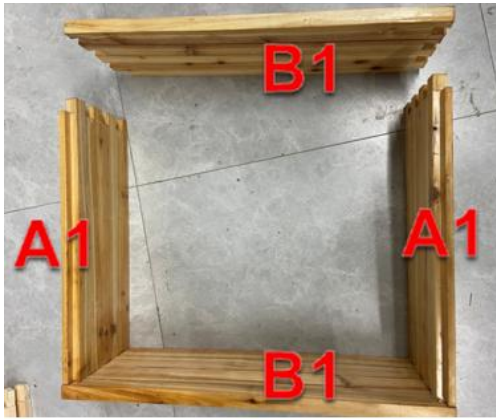

26. Installation du cadre 24 0

Étape 1 : prenez 2 morceaux de **E1** et 1 morceau de **C** , insérez-les dans la fente pour carte pour les connecter, puis prenez 1 morceau de **F1** et insérez-le dans la fente, et enfin prenez 1 morceau de **D** et insérez-le dans la fente. pour compléter un ensemble de 170 cadres.

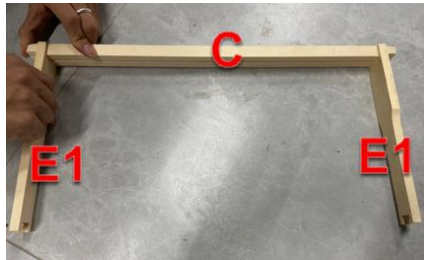

Étape 2 : Connectez-vous avec 4 morceaux de **Q** aux 4 positions a/b/c/d.

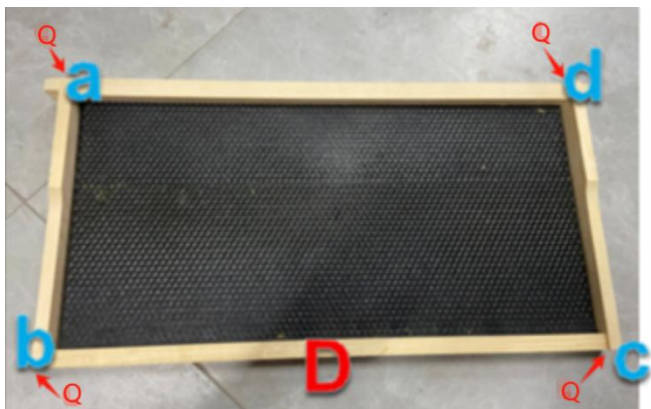

27. Installation de la fenêtre

Étape 1 : Prenez **G** , **H** et **I-1** pour assembler la plaque de recouvrement.



Étape 2 : prenez **S** et décollez le film des coins, puis prenez **S** et **R** pour assembler le surbau.





Étape 3 : Prenez **J** et **K** pour assembler les plaques de pressage des fenêtres des deux côtés et placez 10 jeux de fondations et de cadres dans la boîte.



17 0 BOÎTE

28. Installation d'un coffret 170

Étape 1 : Prenez respectivement deux morceaux de **A2** et deux morceaux de **B2 (B2-1 et B2-2)** et reliez-les avec un marteau en caoutchouc (notez qu'il n'est pas permis de les frapper directement, mais placez une planche ou un carton dessus et frappez-les uniformément).

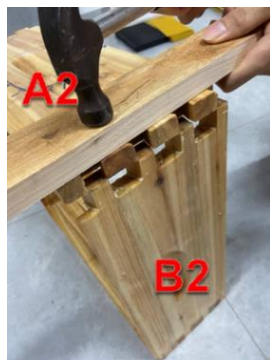
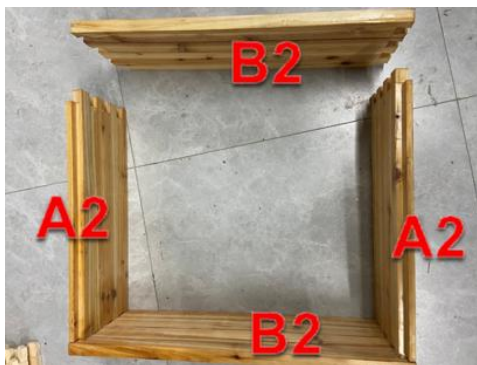

29. cadre 170

Étape 1 : prenez 2 morceaux de **E2** et 1 morceau de **C** , insérez-les dans la fente pour carte pour les connecter, puis prenez 1 morceau de **F2** et insérez-le dans la fente, et enfin prenez 1 morceau de **D** et insérez-le dans la fente. pour compléter un ensemble de 170 cadres.

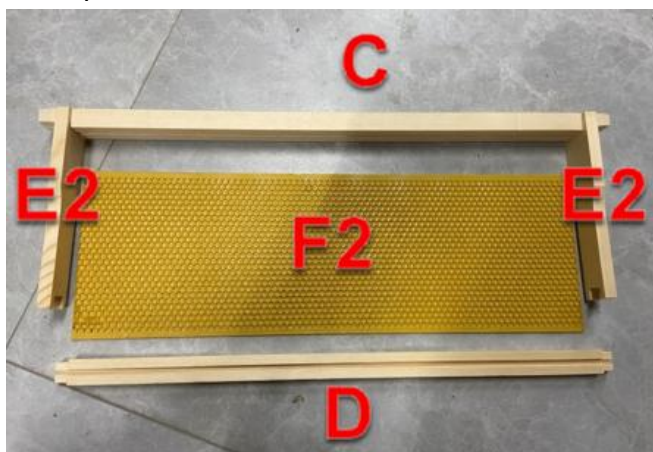

Étape 2 : Connectez-vous avec 4 morceaux de **Q** aux 4 positions a/b/c/d.



30. Installation de la fenêtre

Étape 1 : Prenez **G** , **H** et **I-2** pour assembler la plaque de recouvrement.



Étape 2 : prenez **N** et décollez le film des coins, puis prenez **N** et **M** pour assembler le surbau.





Étape 3 : Prenez **J** et **K** pour assembler les plaques de pressage des fenêtres des deux côtés et placez 10 jeux de fondations et de cadres dans la boîte.

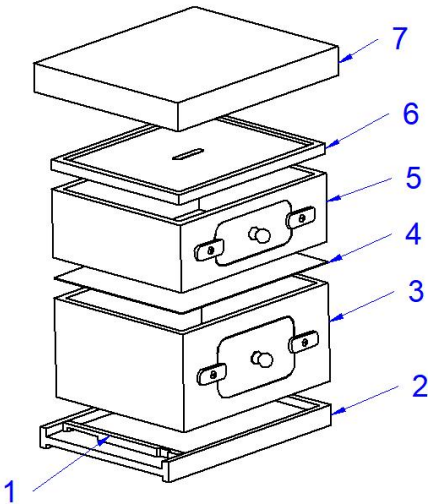

Enfin, veuillez assembler selon la figure suivante :

1. Réducteur d'entrée
2. Panneau inférieur
- 3.240 Boîte

4. Excluseur de reine
5. 170 Boîte
6. Couverture intérieure
7. Couverture supérieure

MAINTENANCE

1. Veuillez utiliser régulièrement de la cire d'abeille pour l'entretien.
2. Fermez la fenêtre abeille par temps froid, pluvieux et venteux.

Fabricant : Shanghai muxinmuyeyouxiangongsi

Adresse : Baoshanqu Shuangchenglu 803long 11hao 1602A-1609shi
Shanghai

Importé en Australie : SIHAO PTY LTD, 1 ROKEVA STREET ASTWOOD
NSW 2122 Australie

Importé aux États-Unis : Sanven Technology Ltd., Suite 250, 9166
Anaheim Place, Rancho Cucamonga, CA 91730



SHUNSHUN GmbH
Römeräcker 9 Z2021, 76351
Linkenheim-Hochstetten, Germany
euvertreter@gmail.com
+49 1727041930



Pooledas Group Ltd
Unit 5 Albert Edward House, The
Pavilions Preston, United Kingdom
pooledas123@gmail.com
01772418127

Fabriqué en Chine

VEVOR[®]

TOUGH TOOLS, HALF PRICE

Technique Assistance et certificat de garantie électronique

www.vevor.com/support

VEVOR[®]

TOUGH TOOLS, HALF PRICE

Technisch Support- und E-Garantiezertifikat www.vevor.com/support

BIENENSTOCK

MODELL: FX1+1

We continue to be committed to provide you tools with competitive price.

"Save Half", "Half Price" or any other similar expressions used by us only represents an estimate of savings you might benefit from buying certain tools with us compared to the major top brands and does not necessarily mean to cover all categories of tools offered by us. You are kindly reminded to verify carefully when you are placing an order with us if you are actually saving half in comparison with the top major brands.

VEVOR®

TOUGH TOOLS, HALF PRICE

BEE HIVE

MODELL: FX 1+1



NEED HELP? CONTACT US!

Have product questions? Need technical support? Please feel free to contact us:

Technical Support and E-Warranty Certificate
www.vevor.com/support

This is the original instruction, please read all manual instructions carefully before operating. VEVOR reserves a clear interpretation of our user manual. The appearance of the product shall be subject to the product you received. Please forgive us that we won't inform you again if there are any technology or software updates on our product.



Warnung: Um das Verletzungsrisiko zu verringern, muss der Benutzer die Bedienungsanleitung sorgfältig lesen.

INSTALLATION NOTES



ANMERKUNGEN :



6. Versuchen Sie, für die Installation einen harten Untergrund zu wählen.
2. Bereiten Sie im Voraus Installationswerkzeuge vor (Gummihammer und Holz).
3. Lesen Sie diese Installationsanleitung sorgfältig durch und überprüfen Sie die Menge des Zubehörs anhand der Liste.



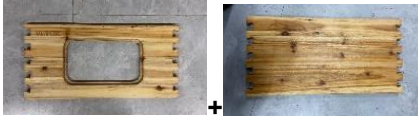

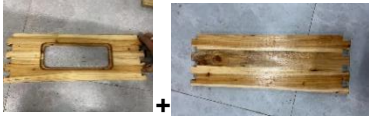

MODEL AND PARAMETERS

Modell	FX1+1
Produktgröße	562*462*515mm
Schrankmaterial	Tannenholz
Oberflächenbehandlung	Prozess des Wachskochens

COMPONENTS

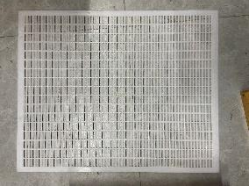
 A1 240 S oaming 1(x 2)	 B 1-1 B 1-2 B 1 24 0 Sülle 2(x 2)
	 B 2-1 B 2-2

<p>Eine 2 17 0 S oaming 1(× 2)</p>	<p>B2 170 Süll 2(× 2)</p>	
 <p>C 170/240 Haupt Rahmenleiste 1(×2 0)</p>	 <p>D 170/240 Haupttrahmenstange 2 (×20)</p>	 <p>E 1 24 0 Rahmenleiste (× 20)</p>
 <p>E2 170 Rahmenstange (× 20)</p>	 <p>F1 240 Fundamentplatte (×10)</p>	 <p>F2 170 Fundamentplatte (×10)</p>
 <p>G- Griff (×2)</p>	 <p>H- Schraube M4x30 (×2)</p>	 <p>Ich -1 Ich -2 I Fensterscheibe (×2)</p>
 <p>J Blechschraube M4x20 (×4)</p>	 <p>K Kleines Brett (×4)</p>	 <p>L obere Abdeckung (× 1)</p>

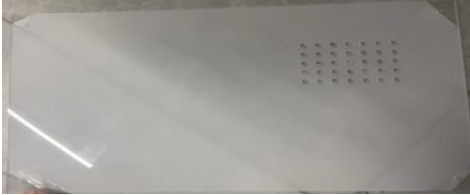
 <p>M Innenabdeckung (× 1)</p>	 <p>N- Bodenplatte (x1)</p>	 <p>O Königin Ausschließer (x1)</p>
 <p>P- Eingangsreduzierer (x1)</p>	 <p>Q- Eisennägel (x80)</p>	 <p>R Selbstschneidende Schraube M3x12 (×8)</p>
 <p>S Acrylfenster (x2)</p>		

ASSEMBLY

240 BOX

31. Installation einer 24 0-Box

Schritt 1: Nehmen Sie zwei Stücke **A1** bzw. zwei Stücke **B1 (B1-1 und B1-2)** und verbinden Sie sie mit einem Gummihammer (beachten Sie, dass Sie nicht direkt darauf klopfen dürfen, sondern ein Brett oder eine Pappe darauf legen und gleichmäßig einklopfen).

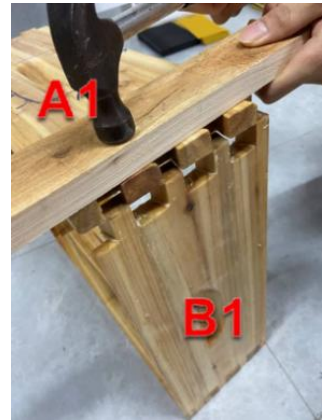
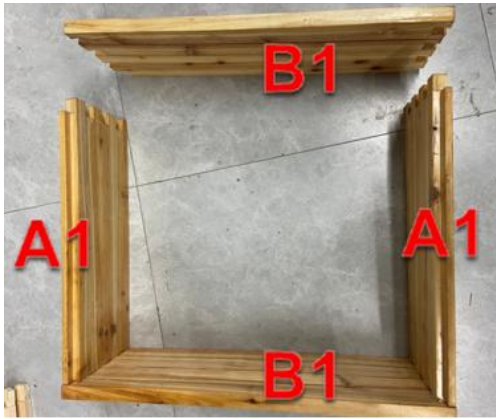

32. Einbau eines 24 0 Rahmens

Schritt 1: Nehmen Sie 2 Stück **E1** und 1 Stück **C**, stecken Sie sie in den Kartensteckplatz, um sie zu verbinden, nehmen Sie dann 1 Stück **F1** und stecken Sie es in den Steckplatz, und nehmen Sie schließlich 1 Stück **D** und stecken Sie es in den Steckplatz um einen Satz von 170 Rahmen zu vervollständigen.

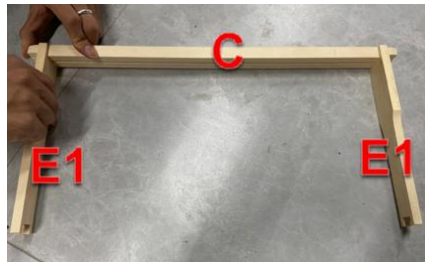

Schritt 2: Verbinden Sie mit 4 **Q**-Stücken an den 4 Positionen a/b/c/d.

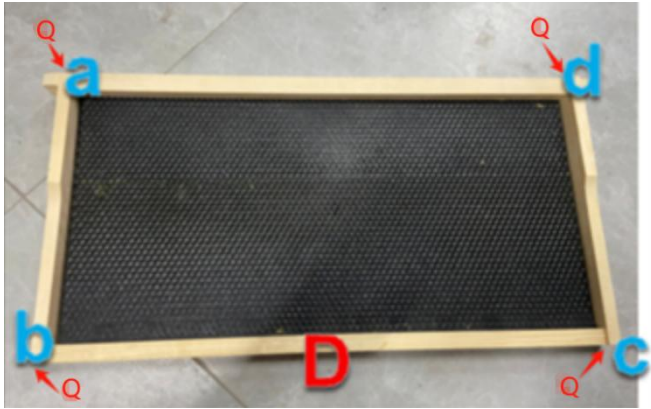

33. Einbau des Fensters

Schritt 1: Nehmen Sie **G** , **H** und **I-1** , um die Abdeckplatte zusammenzubauen.



Schritt 2: Nehmen Sie **S** und ziehen Sie die Folie von den Ecken ab. Nehmen Sie dann **S** und **R** , um den Sull zusammenzubauen.





Schritt 3: Montieren Sie mit **J** und **K** die Fensterpressplatten auf beiden Seiten und legen Sie 10 Sätze Fundamente und Rahmen in den Karton.



17 0 BOX

34. Installation einer 170er-Box

Schritt 1: Nehmen Sie zwei Stücke **A2** bzw. zwei Stücke **B2 (B2-1 und B2-2)** und verbinden Sie sie mit einem Gummihammer (beachten Sie, dass es nicht erlaubt ist, direkt darauf zu klopfen, sondern legen Sie ein Brett oder eine Pappe darauf und gleichmäßig einklopfen).

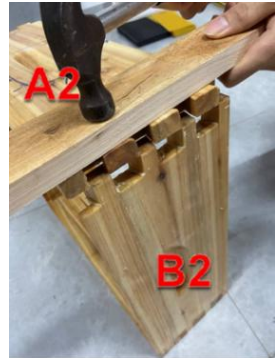
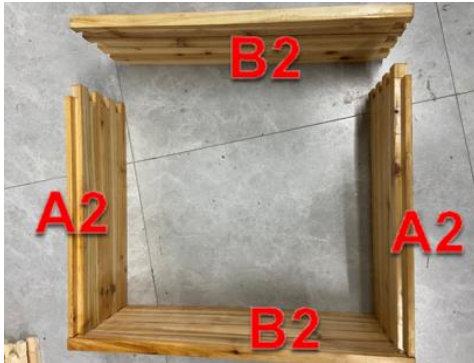

35. Einbau des 170er Rahmens

Schritt 1: Nehmen Sie 2 Stück **E2** und 1 Stück **C**, stecken Sie sie in den Kartensteckplatz, um sie zu verbinden, nehmen Sie dann 1 Stück **F2** und stecken Sie es in den Steckplatz, und nehmen Sie schließlich 1 Stück **D** und stecken Sie es in den Steckplatz um einen Satz von 170 Rahmen zu vervollständigen.

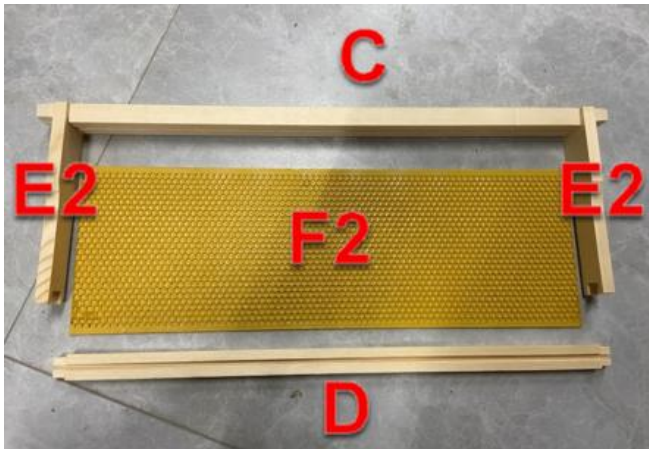

Schritt 2: Verbinden Sie mit 4 **Q**-Stücken an den 4 Positionen a/b/c/d.



36. Einbau des Fensters

Schritt 1: Nehmen Sie **G** , **H** und **I-2** , um die Abdeckplatte zusammenzubauen.



Schritt 2: Nehmen Sie **N** und ziehen Sie die Folie von den Ecken ab. Nehmen Sie dann **N** und **M** , um den SÜll zusammenzubauen.





Schritt 3: Montieren Sie mit **J** und **K** die Fensterpressplatten auf beiden Seiten und legen Sie 10 Sätze Fundamente und Rahmen in den Karton.

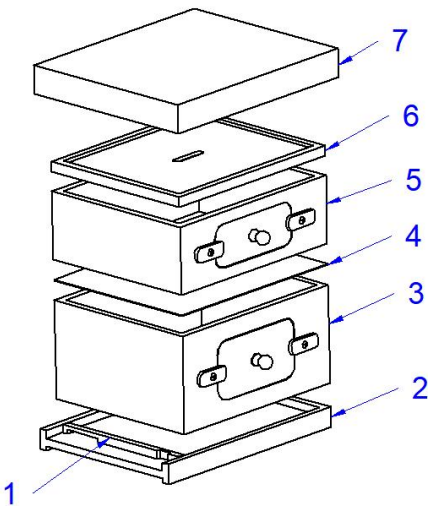

Zum Schluss montieren Sie bitte gemäß der folgenden Abbildung:

1. Eingangsreduzierer
2. Unteres Brett
3. 240 Karton

4. Queen Excluder
- 5.170 Karton
6. Innere Abdeckung
7. Obere Abdeckung

MAINTENANCE

1. Bitte verwenden Sie regelmäßig Bienenwachs zur Pflege.
2. Schließen Sie das Bienenfenster bei kaltem, regnerischem und windigem Wetter.

Hersteller: Shanghaimuxinmuyeyouxiangongsi

Adresse: Baoshanqu Shuangchenglu 803long 11hao 1602A-1609shi
Shanghai

Importiert nach AUS: SIHAO PTY LTD, 1 ROKEVA STREETEASTWOOD
NSW 2122 Australien

In die USA importiert: Sanven Technology Ltd., Suite 250, 9166 Anaheim
Place, Rancho Cucamonga, CA 91730



SHUNSHUN GmbH
Römeräcker 9 Z2021,76351
Linkenheim-Hochstetten, Germany
euvertreter@gmail.com
+49 1727041930



Pooledas Group Ltd
Unit 5 Albert Edward House, The
Pavilions Preston, United Kingdom
pooledas123@gmail.com
01772418127

In China hergestellt

VEVOR[®]
TOUGH TOOLS, HALF PRICE

Technisch Support- und E-Garantiezertifikat
www.vevor.com/support

VEVOR[®]

TOUGH TOOLS, HALF PRICE

Techniczny Certyfikat wsparcia i e-gwarancji www.vevor.com/support

UL PSZCZELI

MODEL: FX1+1

We continue to be committed to provide you tools with competitive price.

"Save Half", "Half Price" or any other similar expressions used by us only represents an estimate of savings you might benefit from buying certain tools with us compared to the major top brands and does not necessarily mean to cover all categories of tools offered by us. You are kindly reminded to verify carefully when you are placing an order with us if you are actually saving half in comparison with the top major brands.

VEVOR®

TOUGH TOOLS, HALF PRICE

BEE HIVE

MODEL: FX 1+1



NEED HELP? CONTACT US!

Have product questions? Need technical support? Please feel free to contact us:

Technical Support and E-Warranty Certificate
www.vevor.com/support

This is the original instruction, please read all manual instructions carefully before operating. VEVOR reserves a clear interpretation of our user manual. The appearance of the product shall be subject to the product you received. Please forgive us that we won't inform you again if there are any technology or software updates on our product.



Ostrzeżenie — aby zmniejszyć ryzyko obrażeń, użytkownik musi uważnie przeczytać instrukcję obsługi.

INSTALLATION NOTES



UWAGI :

7. Spróbuj wybrać twarde podłoże do instalacji.
2. Przygotuj wcześniej narzędzia montażowe (młotek gumowy i drewno) .
3. Przeczytaj uważnie niniejszą instrukcję montażu i potwierdź ilość akcesoriów zgodnie z listą.

MODEL AND PARAMETERS

Model	FX1+1
Rozmiar produktu	562*462*515mm
Materiał szafki	Drewno jodłowe
Obróbka powierzchniowa	Proces gotowania wosku

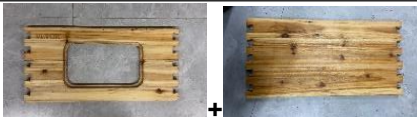
COMPONENTS

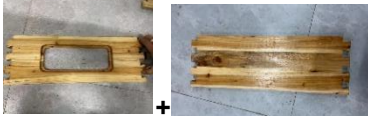
 A1 240 Coating 1(× 2)	 B 1-1 B 1-2 B 1 24 0 Nadziejście 2(× 2)
 2_ 17 0 Nadchodzący 1(×	 B 2-1 B 2-2 B2 170 Zręb 2 (× 2)

2)



C 170/240 Główny pasek ramki 1(×2 0)



D 170/240 Główny pręt ramy 2 (×20)



mi 1 24 0 Pasek ramy (× 20)



Belka ramy **E2** 170 (× 20)



F1 240 (×10)



F2 170 Arkusz fundamentowy (×10)



G (×2)



H Śruba M4x30 (×2)



ja -1 **ja -2**
I Szyba okienna (×2)









J Wkręt samogwintujący M4x20 (×4)



K Mała deska (×4)

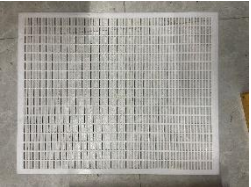

L Górna pokrywa (×1)

 <p>M Osłona wewnętrzna (x1)</p>	 <p>N Płyta dolna (x1)</p>	 <p>O Królowo Wykluczona (x1)</p>
 <p>P (x1)</p>	 <p>Gwoździe żelazne Q (x80)</p>	 <p>R Wkręt samogwintujący M3x12 (x8)</p>
 <p>S Okno z panelu akrylowego (x2)</p>		

ASSEMBLY

240 PUDEŁKO

37. Montaż skrzynki 24 0

Krok 1: Weź odpowiednio dwa kawałki **A1** i dwa kawałki **B1(B1-1 i B1-2)** i połącz je gumowym młotkiem (pamiętaj, że nie wolno w nie uderzać bezpośrednio, ale połóż na nich deskę lub karton i wbij je równomiernie).

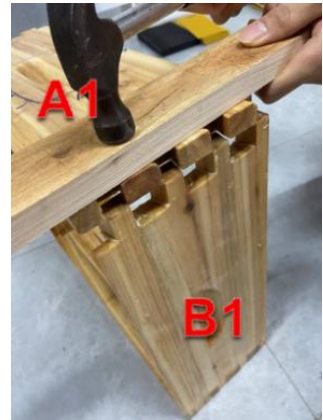
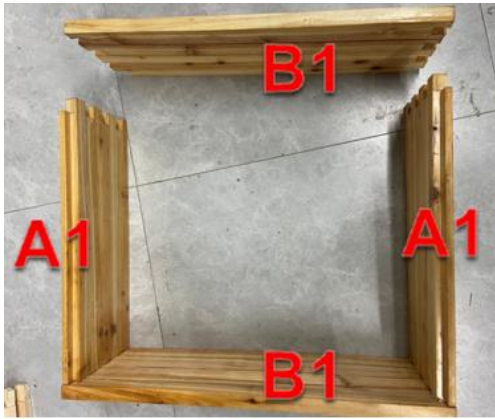

38. Montaż ramy 24 0

Krok 1: Weź 2 elementy E1 i 1 element C, włóż je do gniazda karty, aby je połączyć, następnie weź 1 element F1 i włóż go do gniazda, a na koniec weź 1 element D i włóż go do gniazda aby skompletować zestaw 170 klatek.

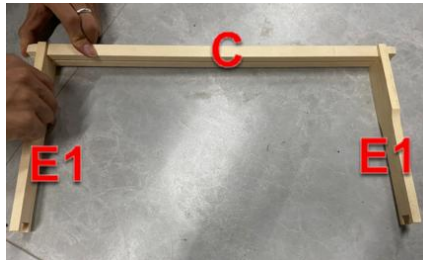

Krok 2: Połącz 4 części Q w 4 pozycjach a/b/c/d.

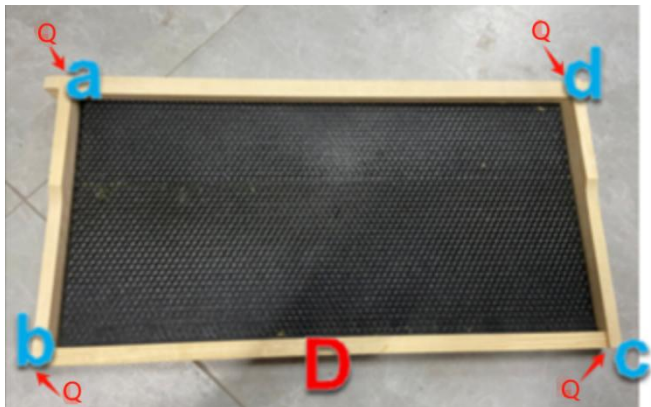

39. Montaż okna

Krok 1: Weź **G** , **H** i **I-1**, aby zamontować pokrywę.



Krok 2: Weź **S** i zdejmij folię z rogów, następnie weź **S** i **R** , aby złożyć zrębnicę.





Krok 3: Weź **J** i **K** , aby zamontować płyty dociskowe okna po obu stronach i włóż do pudełka 10 zestawów fundamentów i ram.



17 0 PUDEŁKO

40. Montaż skrzynki 170

Krok 1: Weź odpowiednio dwa kawałki **A2** i dwa kawałki **B2(B2-1 i B2-2)** i połącz je gumowym młotkiem (pamiętaj, że nie wolno w nie uderzać bezpośrednio, ale połóż na nich deskę lub karton i wbij je równomiernie).

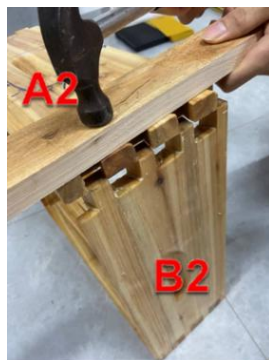
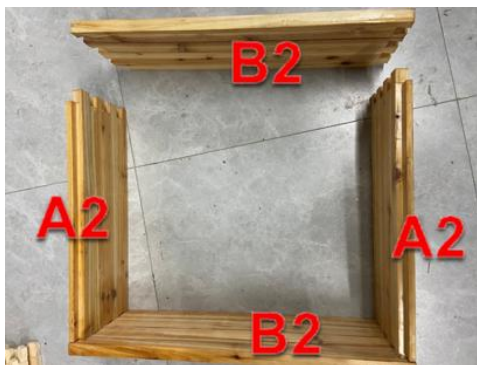

41. Montaż ramy 170

Krok 1: Weź 2 elementy E2 i 1 element C, włóż je do gniazda karty, aby je połączyć, następnie weź 1 element F2 i włóż go do gniazda, a na koniec weź 1 element D i włóż go do gniazda aby skompletować zestaw 170 klatek.

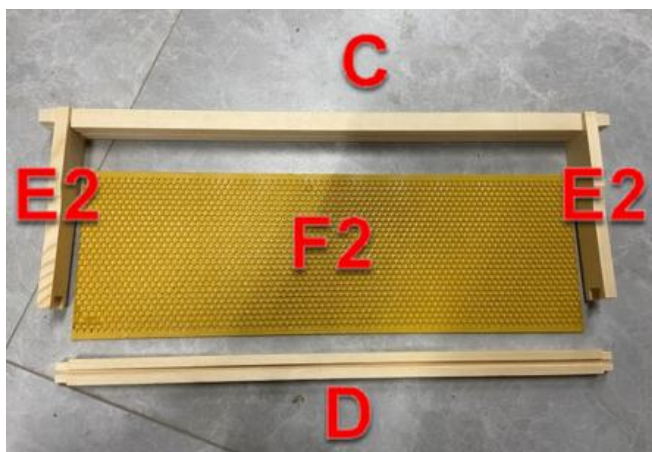

Krok 2: Połącz 4 części Q w 4 pozycjach a/b/c/d.



42. Montaż okna

Krok 1: Weź **G** , **H** i **I-2**, aby zamontować pokrywę.



Krok 2: Weź **N** i zdejmij folię z rogów, następnie weź **N** i **M** , aby złożyć zrębnicę.





Krok 3: Weź J i K , aby zamontować płyty dociskowe okna po obu stronach i włóż do pudełka 10 zestawów fundamentów i ram.

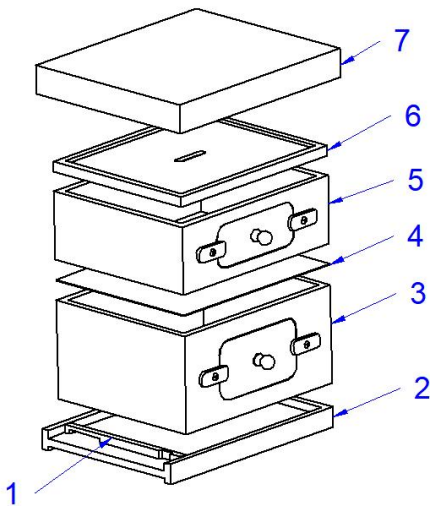

Na koniec zmontuj zgodnie z poniższym rysunkiem:

1. Reduktor wejściowy
2. Płyta dolna
- Pudełko 3.240
4. Wykluczenie królowej

Pudełko 5.170

6. Wewnętrzna osłona

7. Górna pokrywa

MAINTENANCE

1. Do konserwacji należy regularnie używać wosku pszczelego.
2. Zamknij okno dla pszczół, gdy jest zimno, deszczowo i wietrznie.

Producent: Shanghaimuxinmuyeyouxiangongsi

Adres: Baoshanqu Shuangchenglu 803long 11hao 1602A-1609shi
Szanghaj

Import do AUS: SIHAO PTY LTD, 1 ROKEVA STREETEASTWOOD NSW
2122 Australia

Import do USA: Sanven Technology Ltd., Suite 250, 9166 Anaheim Place,
Rancho Cucamonga, CA 91730



SHUNSHUN GmbH
Römeräcker 9 Z2021,76351
Linkenheim-Hochstetten, Germany
euvertreter@gmail.com
+49 1727041930



Pooledas Group Ltd
Unit 5 Albert Edward House, The
Pavilions Preston, United Kingdom
pooledas123@gmail.com
01772418127

Wyprodukowano w Chinach

VEVOR[®]

TOUGH TOOLS, HALF PRICE

Techniczny Certyfikat wsparcia i e-gwarancji

www.vevor.com/support

VEVOR[®]

TOUGH TOOLS, HALF PRICE

Tecnico Supporto e certificato di garanzia elettronica www.vevor.com/support

ALVEARE DELLE API

MODELLO: FX1+1

We continue to be committed to provide you tools with competitive price.

"Save Half", "Half Price" or any other similar expressions used by us only represents an estimate of savings you might benefit from buying certain tools with us compared to the major top brands and does not necessarily mean to cover all categories of tools offered by us. You are kindly reminded to verify carefully when you are placing an order with us if you are actually saving half in comparison with the top major brands.

VEVOR®

TOUGH TOOLS, HALF PRICE

BEE HIVE

MODELLO: FX 1+1



NEED HELP? CONTACT US!

Have product questions? Need technical support? Please feel free to contact us:

Technical Support and E-Warranty Certificate
www.vevor.com/support

This is the original instruction, please read all manual instructions carefully before operating. VEVOR reserves a clear interpretation of our user manual. The appearance of the product shall be subject to the product you received. Please forgive us that we won't inform you again if there are any technology or software updates on our product.



Avvertenza: per ridurre il rischio di lesioni, l'utente deve leggere attentamente il manuale di istruzioni.

INSTALLATION NOTES

APPUNTI :



8. Prova a scegliere un terreno duro per l'installazione.
2. Preparare in anticipo gli strumenti di installazione (martello di gomma e legno) .
3. Leggere attentamente questo manuale di installazione e verificare la quantità di accessori in base all'elenco.







MODEL AND PARAMETERS

Modello	FX1+1
Taglia del prodotto	562*462*515mm
Materiale del mobile	Legno di abete
Trattamento della superficie	Processo di ebollizione della cera

COMPONENTS

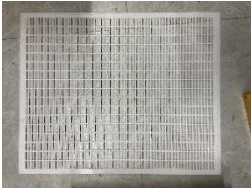
 A1 240 C oaming 1(× 2)	 B1-1 B1-2 __ B1_24 0 Mastra 2(× 2)
	 B2-1 B2-2 __

Un 2 17 0 C oaming 1(× 2)	B2 170 Mastra 2(× 2)	
 <p>C 170/240 Principale barra del frame 1(×2 0)</p>	 <p>D 170/240 Barra del telaio principale 2 (×20)</p>	 <p>E1 _ 24 0 Barra del telaio (× 20)</p>
 <p>Barra telaio E2 170 (× 20)</p>	 <p>F1 240 Foglio di fondazione (×10)</p>	 <p>F2 170 Foglio di fondazione (×10)</p>
 <p>G (×2)</p>	 <p>H Vite M4x30 (×2)</p>	 <p>Io -1 Io -2 I Riquadro della finestra (×2)</p>
 <p>J Vite autofilettante M4x20 (×4)</p>	 <p>K Asse piccola (×4)</p>	 <p>L Coperchio superiore (× 1)</p>

 <p>M Copertura interna (× 1)</p>	 <p>N Pannello inferiore (x1)</p>	 <p>O Regina Esclusiva (x1)</p>
 <p>P Riduttore ingresso(x1)</p>	 <p>Chiodi in ferro Q (x80)</p>	 <p>R Vite autofilettante M3x12 (×8)</p>
 <p>S Finestra con pannello acrilico (x2)</p>		

ASSEMBLY

240 SCATOLA

43. Installazione della scatola 24 0

Passaggio 1: prendere rispettivamente due pezzi di **A1** e due pezzi di **B1** (**B1-1** e **B1-2**) e collegarli con un martello di gomma (notare che non è consentito colpirli direttamente, ma mettere una tavola o un cartone su di essi e inserirli uniformemente).

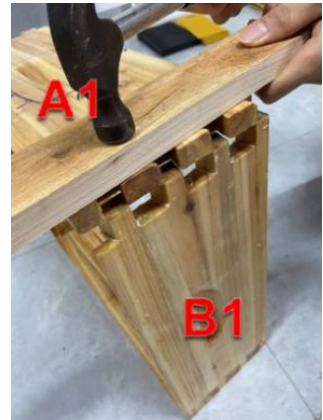
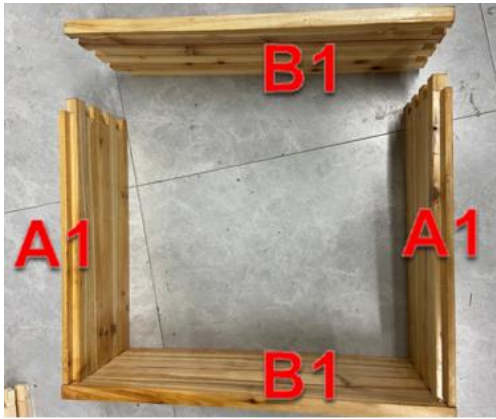

44. Installazione del telaio 24 0

Passaggio 1: prendi 2 pezzi di **E1** e 1 pezzo di **C** , inseriscili nello slot della scheda per collegarli, quindi prendi 1 pezzo di **F1** e inseriscilo nello slot, infine prendi 1 pezzo di **D** e inseriscilo nello slot per completare un set di 170 fotogrammi.

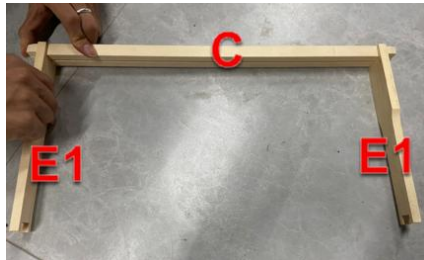

Passaggio 2: Connettiti con 4 pezzi di **Q** nelle 4 posizioni a/b/c/d.

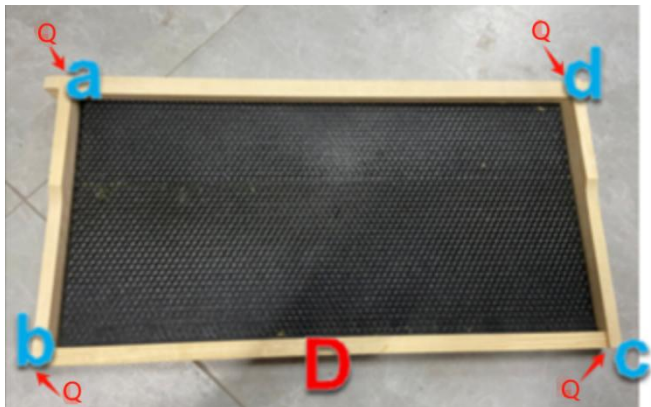

45. Installazione della finestra

Passaggio 1: prendere **G** , **H** e **I-1** per assemblare la piastra di copertura.



Passaggio 2: prendi **S** e rimuovi la pellicola dagli angoli, quindi prendi **S** e **R** per assemblare la mastra.





Passaggio 3: prendi **J** e **K** per assemblare le piastre di pressatura delle finestre su entrambi i lati e metti 10 set di fondazioni e telai nella scatola.



17 0 SCATOLA

46. Installazione di scatola da 170

Passaggio 1: prendere rispettivamente due pezzi di **A2** e due pezzi di **B2** (**B2-1** e **B2-2**) e collegarli con un martello di gomma (notare che non è consentito colpirli direttamente, ma mettere una tavola o un cartone su di essi e inserirli uniformemente).

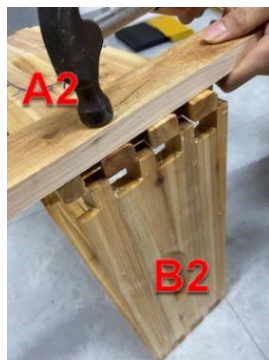
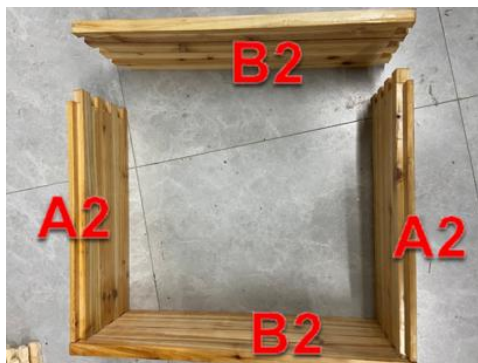

47. telaio 170

Passaggio 1: prendi 2 pezzi di **E2** e 1 pezzo di **C** , inseriscili nello slot della scheda per collegarli, quindi prendi 1 pezzo di **F2** e inseriscilo nello slot, infine prendi 1 pezzo di **D** e inseriscilo nello slot per completare un set di 170 fotogrammi.

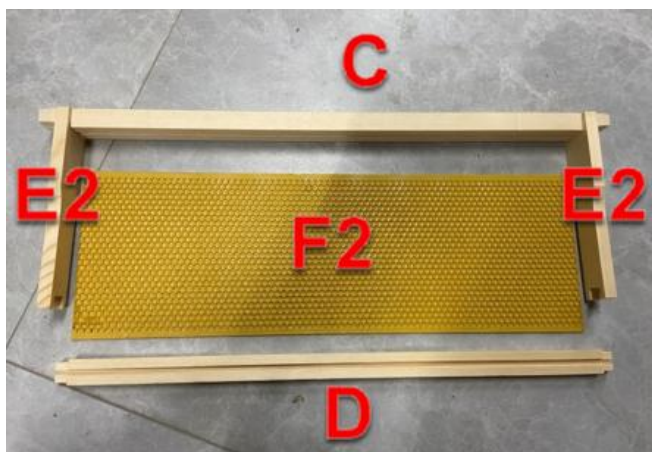

Passaggio 2: Connettiti con 4 pezzi di **Q** nelle 4 posizioni a/b/c/d.



48. Installazione della finestra

Passaggio 1: prendere **G** , **H** e **I-2** per assemblare la piastra di copertura.



Passaggio 2: prendi **N** e rimuovi la pellicola dagli angoli, quindi prendi **N** e **M** per assemblare la mastra.





Passaggio 3: prendi J e K per assemblare le piastre di pressatura delle finestre su entrambi i lati e metti 10 set di fondazioni e telai nella scatola.

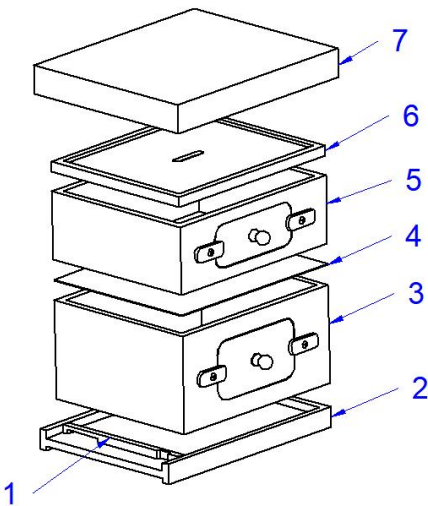

Infine, assemblare secondo la seguente figura:

1. Riduttore d'ingresso
2. Pannello inferiore
3. 240 Scatola
4. Escludi Regina

- 5.170 Scatola
6. Copertura interna
7. Coperchio superiore

MAINTENANCE

1. Si prega di utilizzare regolarmente la cera d'api per la manutenzione.
2. Chiudi la finestra delle api in caso di tempo freddo, piovoso e ventoso.

Produttore: Shanghaimuxinmuyeyouxiangongsi

Indirizzo: Baoshanqu Shuangchenglu 803long 11hao 1602A-1609shi
Shanghai

Importato in AUS: SIHAO PTY LTD, 1 ROKEVA STREET EASTWOOD
NSW 2122 Australia

Importato negli Stati Uniti: Sanven Technology Ltd., Suite 250, 9166
Anaheim Place, Rancho Cucamonga, CA 91730



SHUNSHUN GmbH
Römeräcker 9 Z2021,76351
Linkenheim-Hochstetten, Germany
euvertreter@gmail.com
+49 1727041930



Pooledas Group Ltd
Unit 5 Albert Edward House, The
Pavilions Preston, United Kingdom
pooledas123@gmail.com
01772418127

Made in China

VEVOR[®]

TOUGH TOOLS, HALF PRICE

Tecnico Supporto e certificato di garanzia elettronica

www.vevor.com/support