

# **VEVOR<sup>®</sup>**

## **TOUGH TOOLS, HALF PRICE**

Technical Support and E-Warranty Certificate [www.vevor.com/support](http://www.vevor.com/support)

### **DOG CRATE USER MANUAL**

We continue to be committed to provide you tools with competitive price.

"Save Half", "Half Price" or any other similar expressions used by us only represents an estimate of savings you might benefit from buying certain tools with us compared to the major top brands and does not necessarily mean to cover all categories of tools offered by us. You are kindly reminded to verify carefully when you are placing an order with us if you are actually saving half in comparison with the top major brands.



# VEVOR®

TOUGH TOOLS, HALF PRICE

## DOG CRATE

Model: C20230602W-02

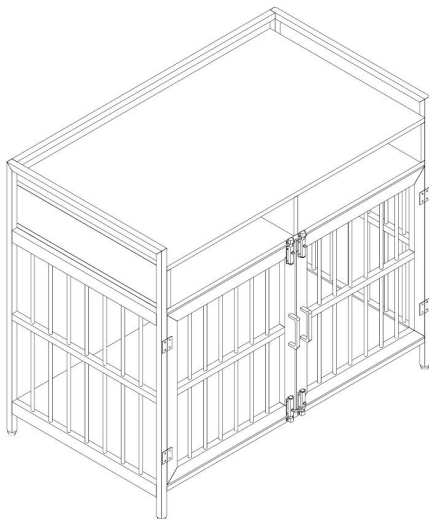

### NEED HELP? CONTACT US!

Have product questions? Need technical support? Please feel free to contact us:

**Technical Support and E-Warranty Certificate**  
**[www.vevor.com/support](http://www.vevor.com/support)**

This is the original instruction, please read all manual instructions carefully before operating. VEVOR reserves a clear interpretation of our user manual. The appearance of the product shall be subject to the product you received. Please forgive us that we won't inform you again if there are any technology or software updates on our product.

# SAFETY NOTICE

Read this material before using this product. Failure to do so can result in serious injury.

## Assembly precautions

1. Assemble only according to these instructions. Improper assembly can create hazards.
2. In order to ensure your own safety, please make sure to ANSI-approved safety goggles and heavy-duty work gloves when installing this product.
3. Keep the assembly area clean and well lit.
4. Keep bystanders out of the area during assembly.
5. Do not assemble when tired or when under the influence of alcohol, drugs or medication.
6. Product capabilities apply to properly and completely assembled products only.
7. Assemble on a flat, level, hard and smooth surface capable of safely supporting a fully loaded dog cage.

## Use precautions

### TO PREVENT SERIOUS INJURY AND DEATH FROM TIPPING:











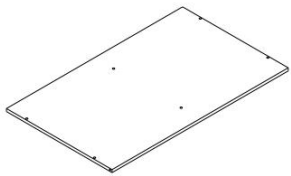
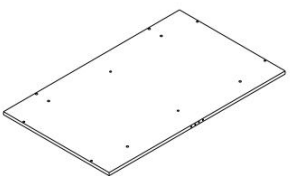
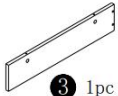
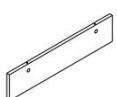
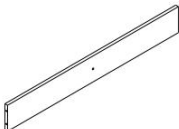
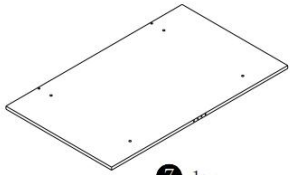









1. DO NOT SIT, STAND OR CLIMB ON THIS ITEM.
2. This product is not a toy. Do not allow children to play with or near this item. Please keep small spare parts out of children's reach.
3. Use only on a flat, level, hard and smooth surface capable of safely supporting a fully loaded dog cage.
4. Use as intended only.
5. Inspect before every use; do not use if parts are loose or damaged.

# SAVE THESE INSTRUCTIONS

## SPECIFICATIONS

Model	C20230602W-02
Product Size	41*23.6*36.2in
Color	Brown

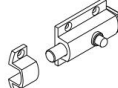
# COMPONENTS

 <p><b>1</b> 1pc</p>		 <p><b>2</b> 1pc</p>		 <p><b>3</b> 1pc</p>	
 <p><b>5</b> 1pc</p>		 <p><b>6</b> 1pc</p>		 <p><b>7</b> 1pc</p>	
 <p><b>9</b> 1pc</p>		 <p><b>10</b> 1pc</p>		 <p><b>11</b> 2pcs</p>	
		 <p><b>12</b> 4pcs</p>		 <p><b>13</b> 1pc</p>	
 <p><b>A</b> 9pcs</p>		 <p><b>B</b> 16pcs</p>		 <p><b>C</b> 9pcs</p>	
 <p><b>D</b> 5pcs</p>		 <p><b>E</b> 9pcs</p>			
 <p><b>H</b> 11pcs</p>		 <p><b>S</b> 5pcs</p>		 <p><b>K</b> 2pcs</p>	
 <p><b>N</b> 9pcs</p>		 <p><b>L</b> 17pcs</p>		 <p><b>Y</b> 4pcs</p>	
 <p><b>Q</b> 11pcs</p>		 <p><b>X</b> 1pc</p>		 <p><b>R</b> 4pcs</p>	
					

# Assembly Instructions

## Installation of Cams and Pins

Screw the pin into the hole. To set the cams correctly, ensure that the arrow on the cam is opening to the hole of the pin it is locking. Lock the cam by turning tightened. Please do not use an electric screwdriver to assemble the unit. the cam head with a screwdriver until it .

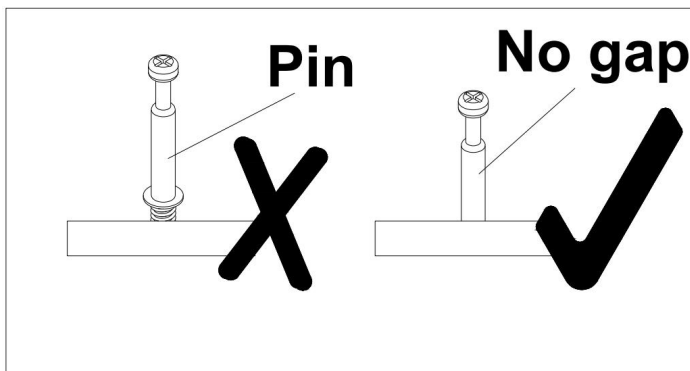
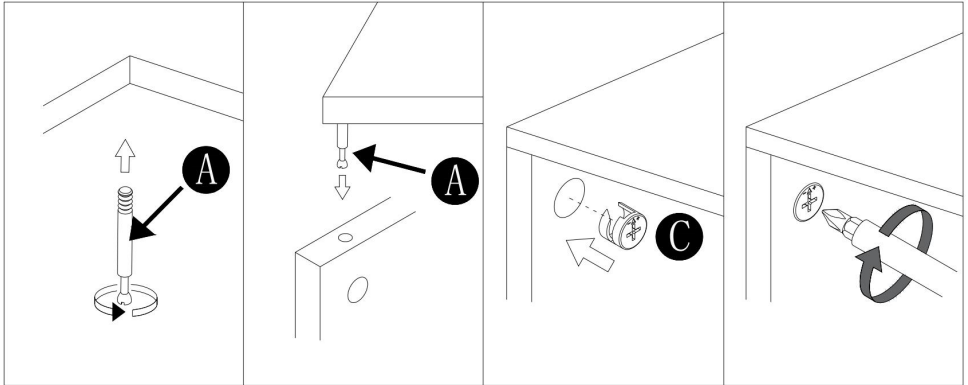

Read each step carefully before starting. It is very important that each step of instruction is performed in the correct order. If these steps are not followed in sequence, assembly difficulties will occur.

**STEP1**

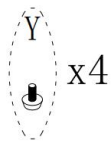
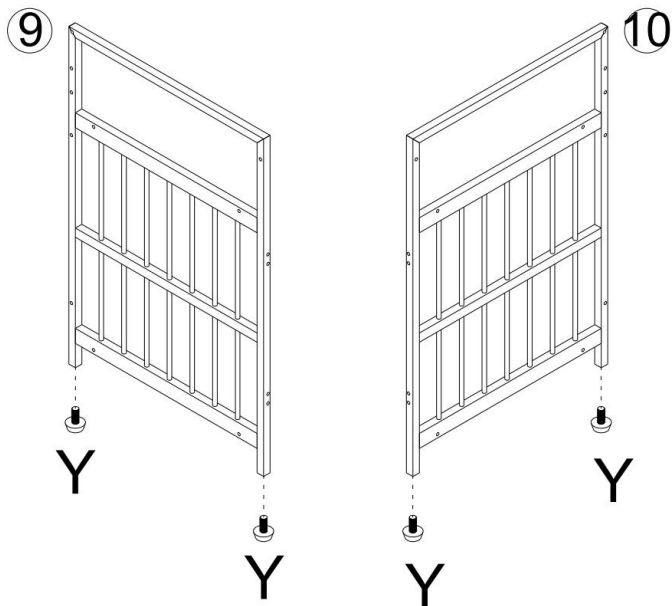

**STEP2**

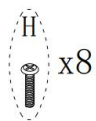
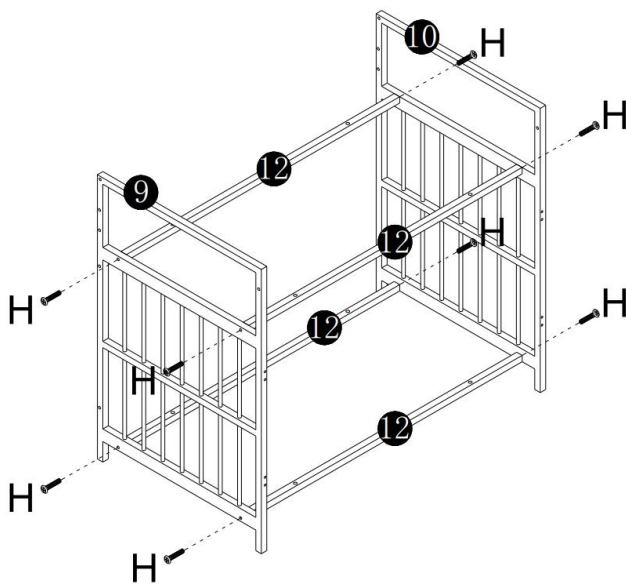

**STEP3**

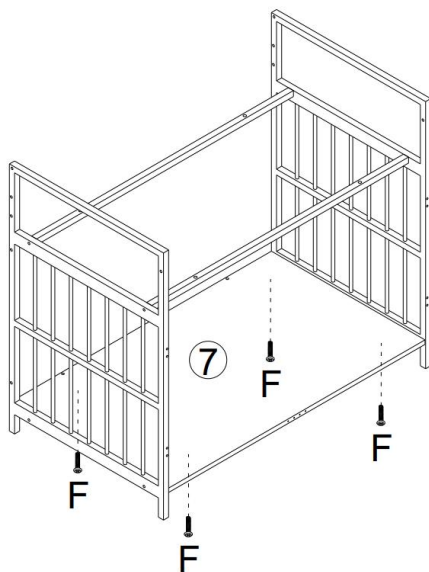
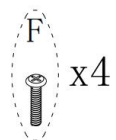

**STEP4**

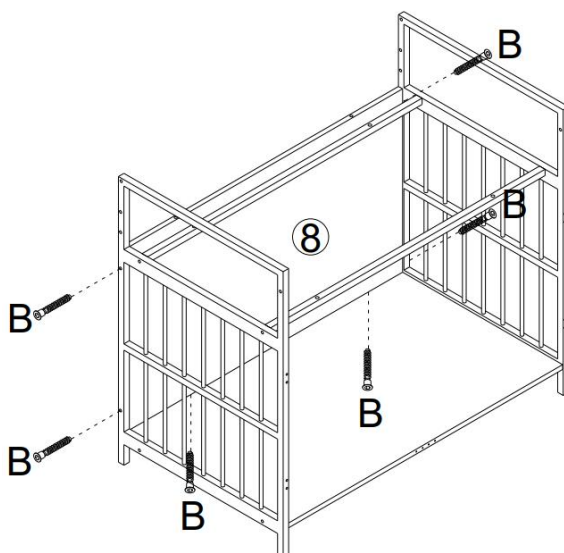
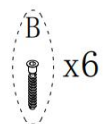



STEP5

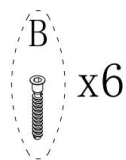
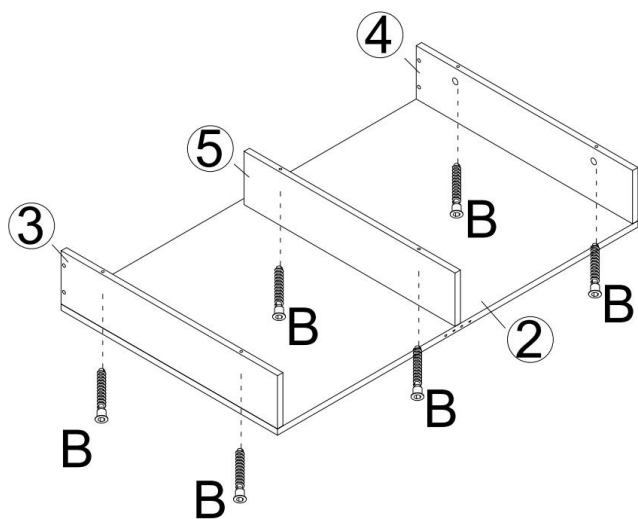

STEP6

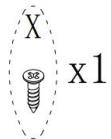
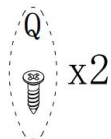
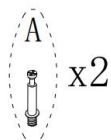
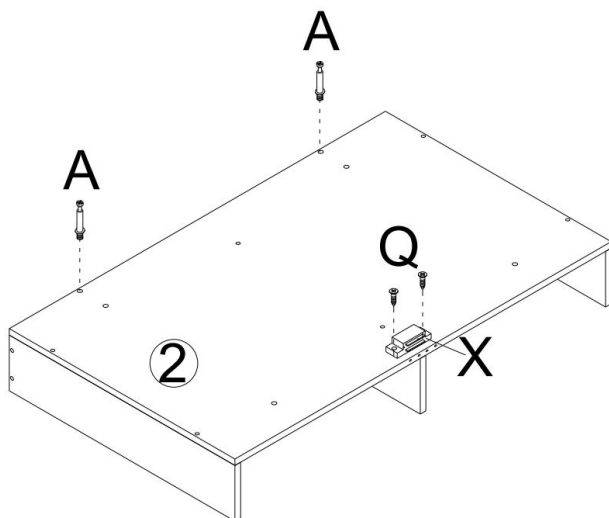

## STEP7

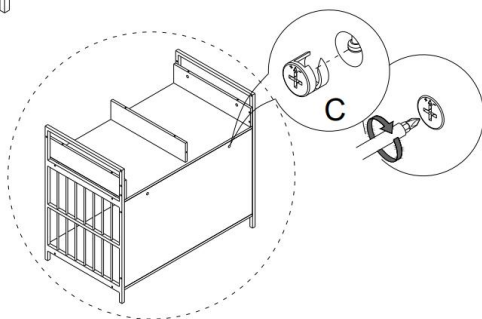
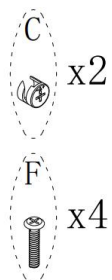
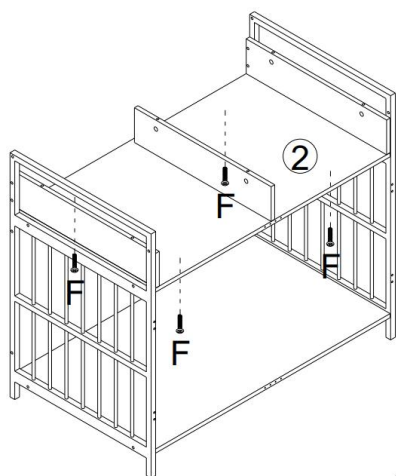

## STEP8

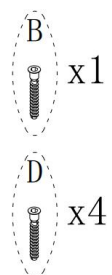
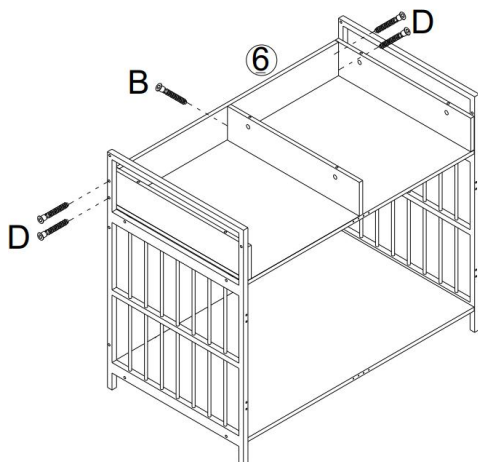

**STEP9**

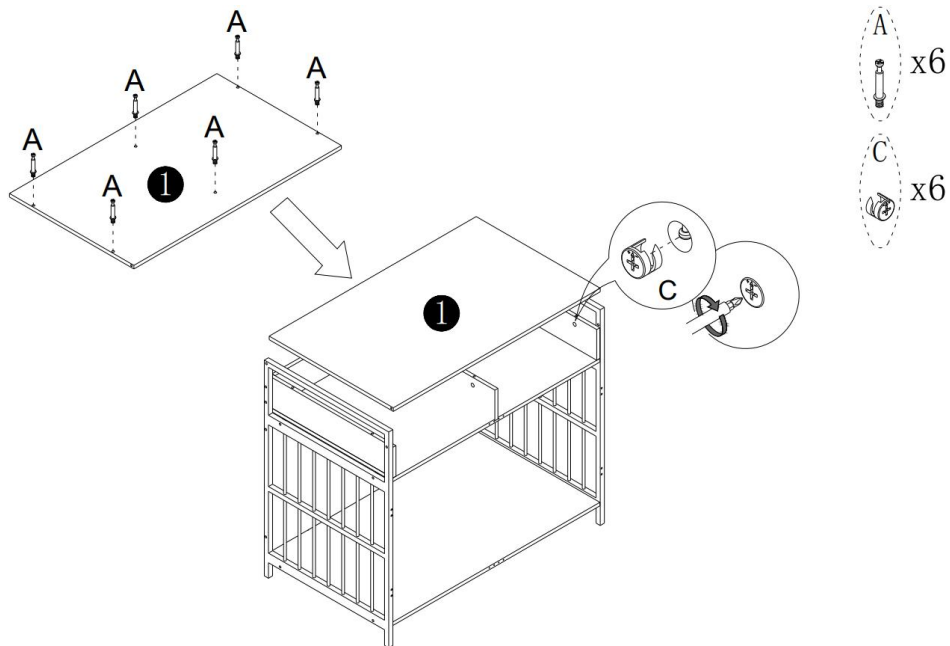

**STEP10**

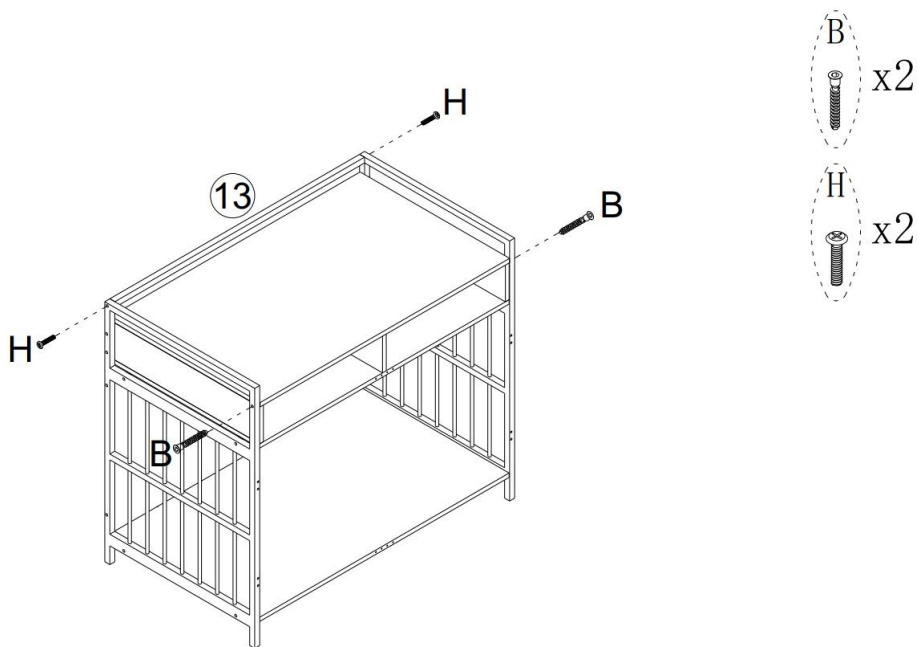

**STEP11**

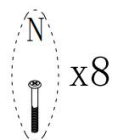
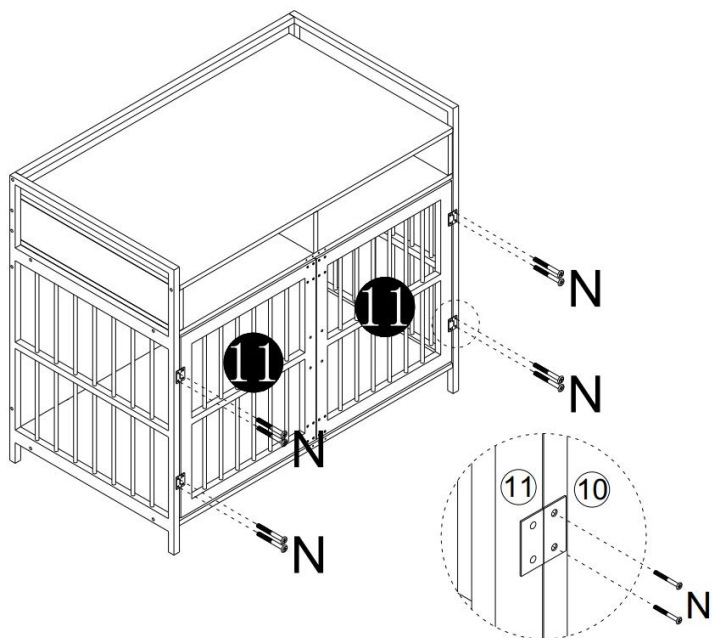

**STEP12**

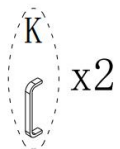
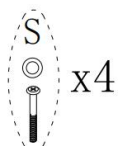
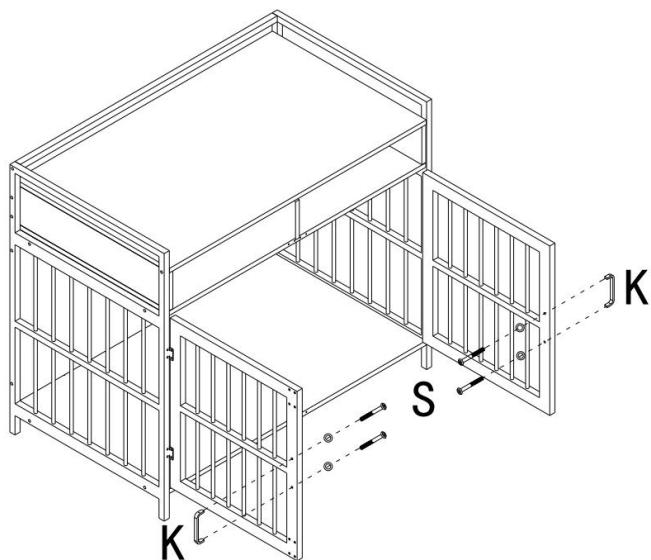

### STEP13

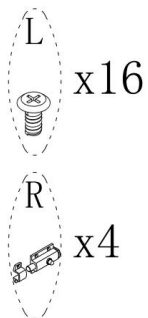
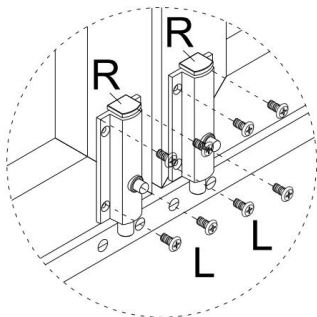
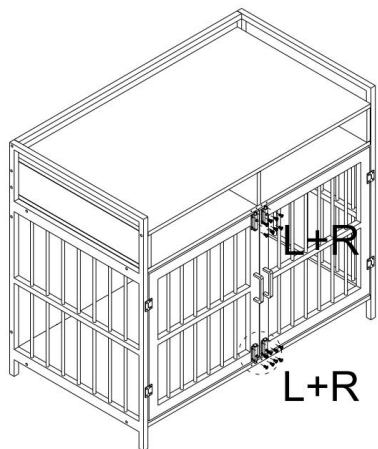

### STEP14

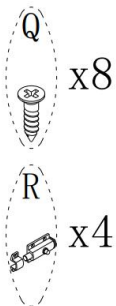
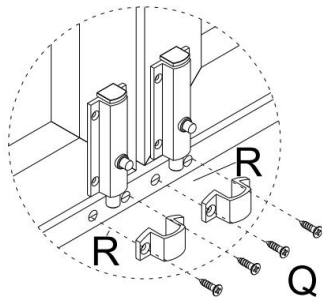
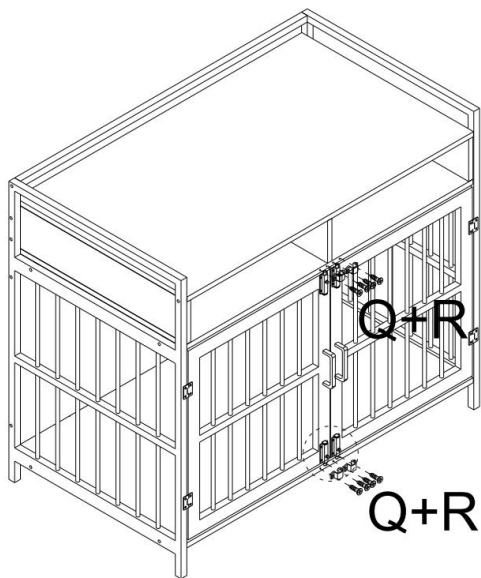

Note: Lock this accessory , the latch is a little stuck, please turn this accessory to install.

Manufacturer: Shanghaimuxinmuyeyouxiangongsi  
Address: Shuangchenglu 803nong11hao1602A-1609shi, baoshanqu, shanghai  
200000 CN.  
EC REP: E-CrossStu GmbH.  
Mainzer Landstr.69, 60329 Frankfurt am Main.  
UK REP: YH CONSULTING LIMITED.  
C/O YH Consulting Limited Office 147, Centurion House, London Road, Staines-  
upon-Thames, Surrey, TW18 4AX  
Imported to AUS: SIHAO PTY LTD.  
1 ROKEVA STREETEASTWOOD NSW 2122 Australia  
Imported to USA: Sanven Technology Ltd.  
Suite 250, 9166 Anaheim Place, Rancho Cucamonga, CA 91730



**VEVOR<sup>®</sup>**

**TOUGH TOOLS, HALF PRICE**

**Technical Support and E-Warranty Certificate**

**[www.vevor.com/support](http://www.vevor.com/support)**



# **VEVOR<sup>®</sup>**

## **TOUGH TOOLS, HALF PRICE**

Technischer Support und E-Garantie-Zertifikat [www.vevor.com/support](http://www.vevor.com/support)

### **BENUTZERHANDBUCH FÜR HUNDEBOXEN**

Wir sind weiterhin bestrebt, Ihnen Werkzeuge zu wettbewerbsfähigen Preisen anzubieten.

„Sparen Sie die Hälfte“, „Halber Preis“ oder andere ähnliche Ausdrücke, die wir verwenden, stellen nur eine Schätzung der Ersparnis dar, die Sie beim Kauf bestimmter Werkzeuge bei uns im Vergleich zu den großen Topmarken erzielen können, und decken nicht unbedingt alle von uns angebotenen Werkzeugkategorien ab. Wir möchten Sie freundlich daran erinnern, bei Ihrer Bestellung bei uns sorgfältig zu prüfen, ob Sie im Vergleich zu den großen Topmarken tatsächlich die Hälfte sparen.



**VEVOR**<sup>®</sup>  
TOUGH TOOLS, HALF PRICE

**Hundebox**

Modell: C20230602W-02

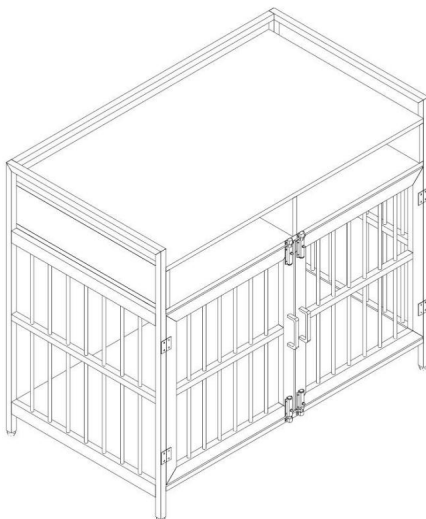

**Brauchen Sie Hilfe? Kontaktieren Sie uns!**

Sie haben Fragen zu unseren Produkten? Sie benötigen technischen Support? Dann kontaktieren Sie uns gerne:

**Technischer Support und E-Garantie-Zertifikat**  
**[www.vevor.com/support](http://www.vevor.com/support)**

Dies ist die Originalanleitung. Bitte lesen Sie alle Anweisungen sorgfältig durch, bevor Sie das Gerät in Betrieb nehmen. VEVOR behält sich eine klare Auslegung unserer Bedienungsanleitung vor. Das Erscheinungsbild des Produkts richtet sich nach dem Produkt, das Sie erhalten haben. Bitte verzeihen Sie uns, dass wir Sie nicht erneut informieren, wenn es Technologie- oder Software-Updates für unser Produkt gibt.

## SICHERHEITSHINWEIS

Lesen Sie dieses Material, bevor Sie dieses Produkt verwenden. Die Nichtbeachtung kann zu schweren

Verletzung.

### Vorsichtsmaßnahmen bei der Montage

1. Die Montage muss gemäß dieser Anleitung erfolgen. Eine unsachgemäße Montage kann Gefahren.
2. Um Ihre eigene Sicherheit zu gewährleisten, achten Sie bitte auf ANSI-geprüfte Sicherheits Tragen Sie bei der Installation dieses Produkts eine Schutzbrille und strapazierfähige Arbeitshandschuhe.
3. Halten Sie den Versammlungsbereich sauber und gut beleuchtet.
4. Halten Sie während der Montage unbeteiligte Zuschauer vom Bereich fern.
5. Montieren Sie nicht, wenn Sie müde sind oder unter dem Einfluss von Alkohol, Drogen oder Medikamente.
6. Die Produktfunktionen gelten nur für ordnungsgemäß und vollständig montierte Produkte.
7. Auf einer flachen, ebenen, harten und glatten Oberfläche montieren, die sicher tragen kann ein voll beladener Hundekäfig.

### Vorsichtsmaßnahmen treffen

#### UM SCHWERE VERLETZUNGEN UND TOD DURCH KIPPEN ZU VERMEIDEN:

1. Setzen, stellen oder klettern Sie nicht auf diesen Gegenstand.
2. Dieses Produkt ist kein Spielzeug. Erlauben Sie Kindern nicht, mit diesem Produkt zu spielen oder sich in seiner Nähe aufzuhalten. Bitte bewahren Sie kleine Ersatzteile außerhalb der Reichweite von Kindern auf.
3. Nur auf einer flachen, ebenen, harten und glatten Oberfläche verwenden, die ein voll beladener Hundekäfig.
4. Nur bestimmungsgemäß verwenden.
5. Vor jedem Gebrauch prüfen; nicht verwenden, wenn Teile lose oder beschädigt sind.

## BEWAHREN SIE DIESE ANWEISUNGEN AUF

### Spezifikationen

Modell	C20230602W-02
Produktgröße	41*23,6*36,2 Zoll
Farbe	Braun

# KOMPONENTEN

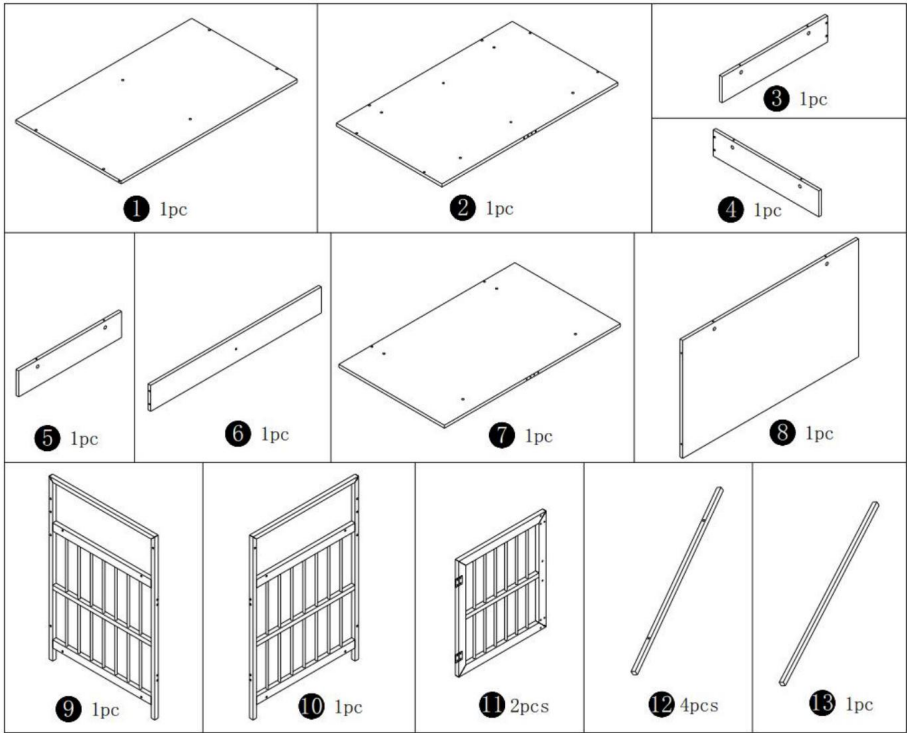

# Montageanleitung

## Installation von Nocken und Stiften

Schrauben Sie den Stift in das Loch. Um die Nocken richtig einzustellen, achten Sie darauf, dass der Pfeil auf dem Nocken nach außen zeigt.

das Loch des Stiftes, der verriegelt wird. Verriegeln Sie die Nocke durch Festdrehen. Bitte verwenden Sie keinen elektrischen

Schraubendreher, um die Einheit zusammenzusetzen. Den Nockenkopf mit einem Schraubendreher festziehen, bis er .

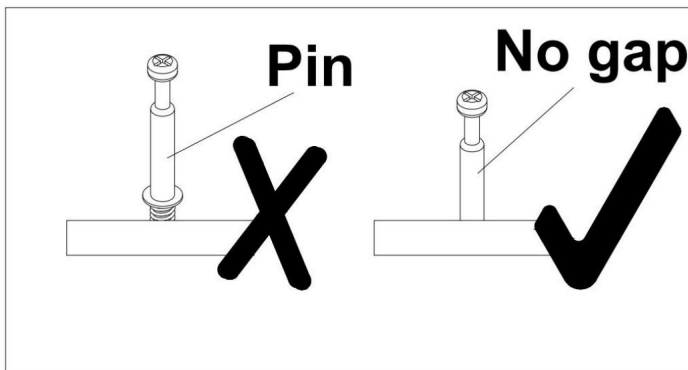
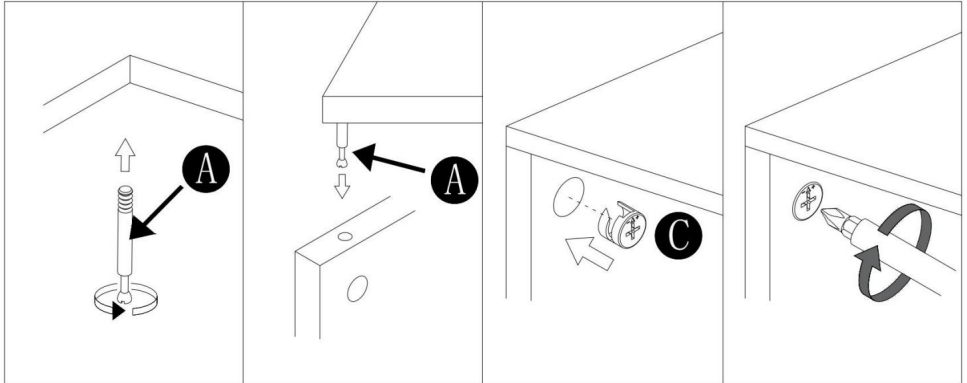

Lesen Sie jeden Schritt sorgfältig durch, bevor Sie beginnen. Es ist sehr wichtig, dass jeder Schritt der Anleitung genau

in der richtigen Reihenfolge. Wenn diese Schritte nicht in der richtigen Reihenfolge befolgt werden, treten Montageschwierigkeiten auf.

SCHRITT 1

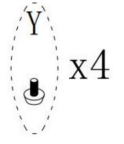
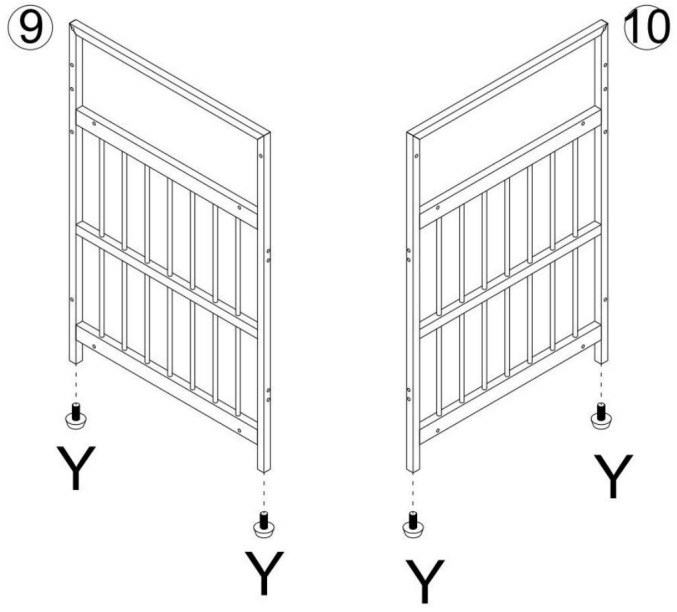

SCHRITT 2

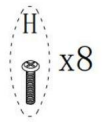
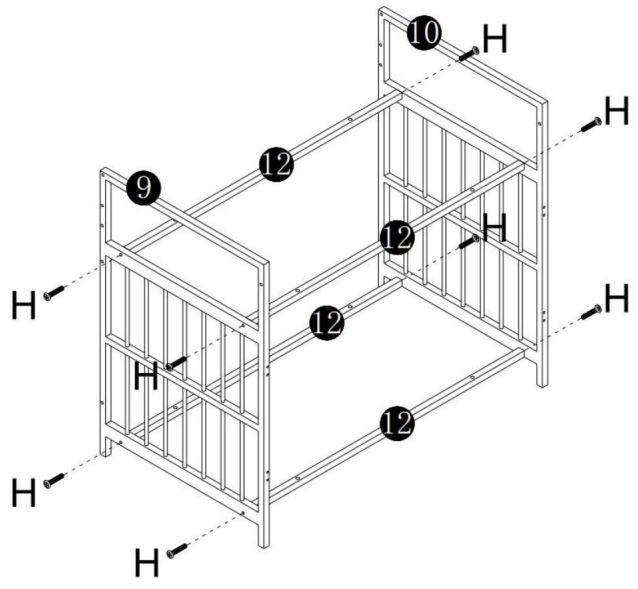

SCHRITT3

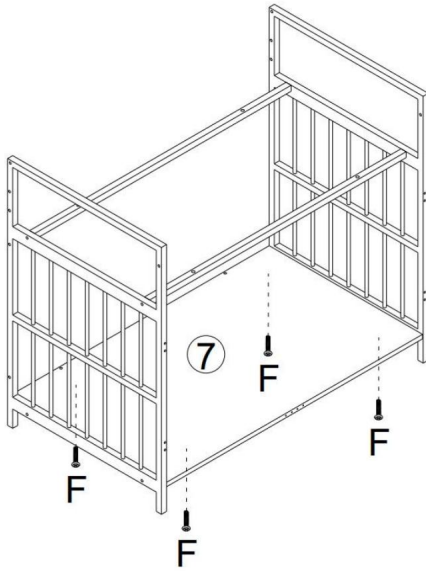
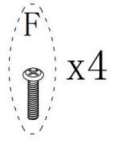

SCHRITT4

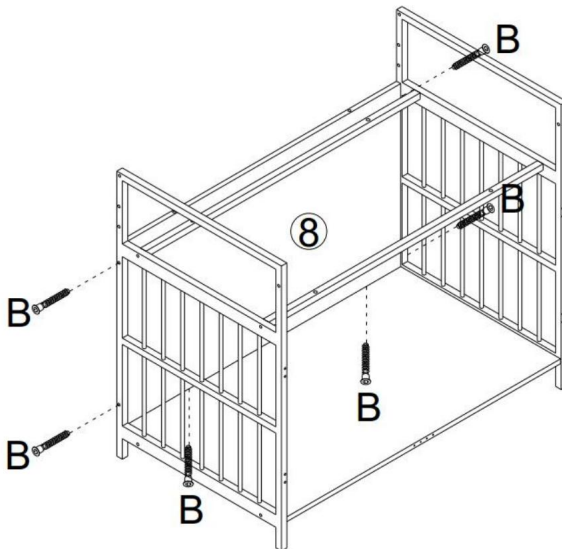
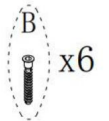



SCHRITT 5

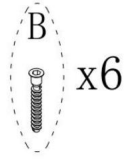
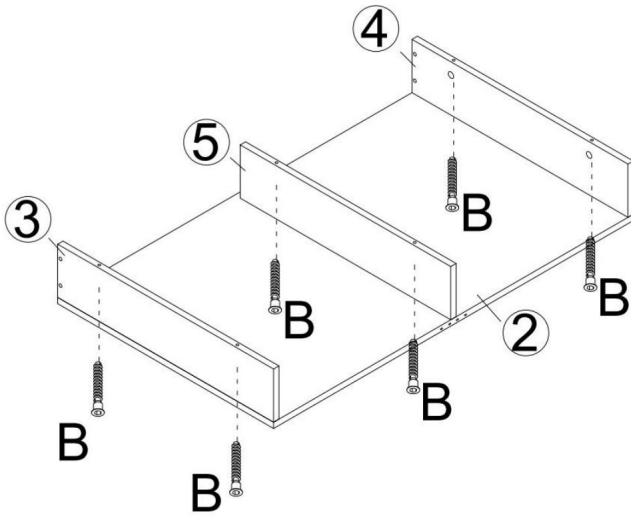

SCHRITT 6

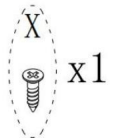
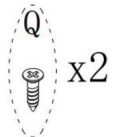
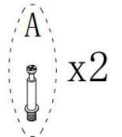
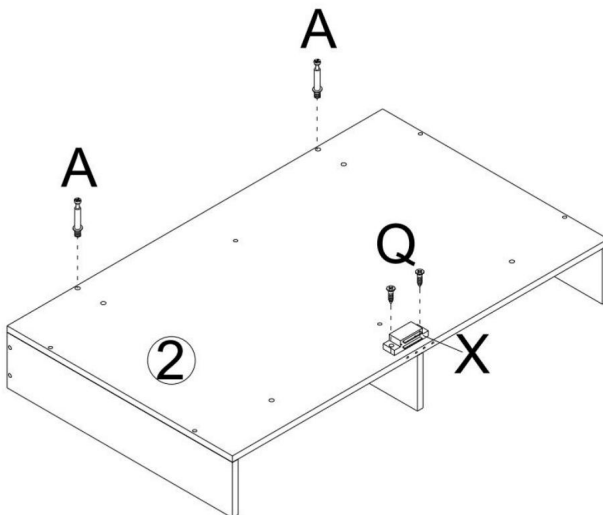

SCHRITT 7

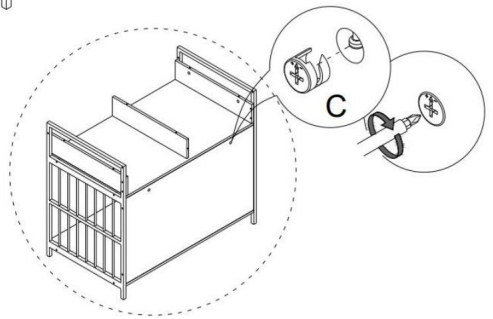
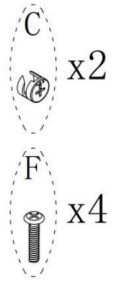
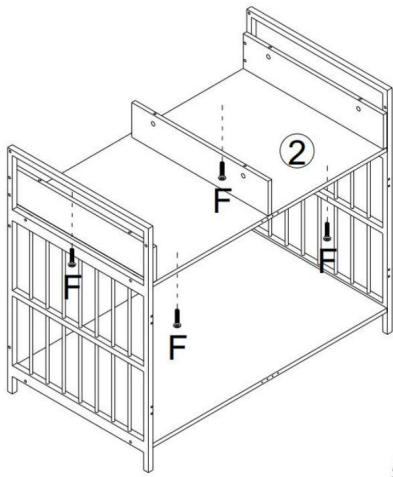

SCHRITT 8

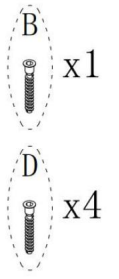
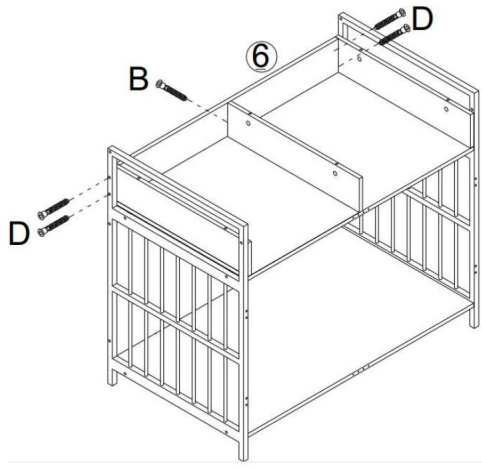

SCHRITT9

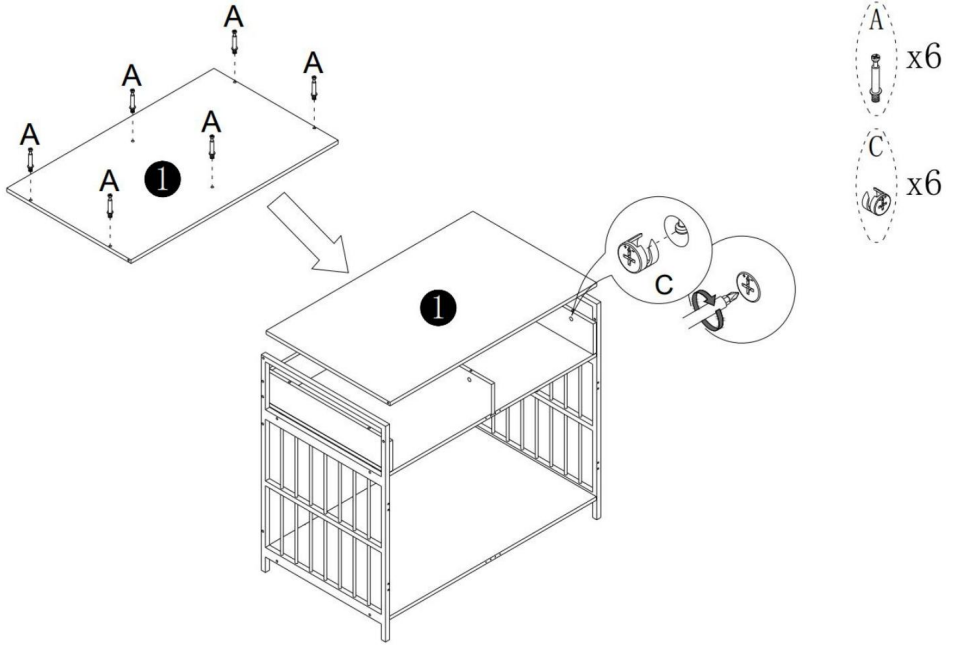

SCHRITT10

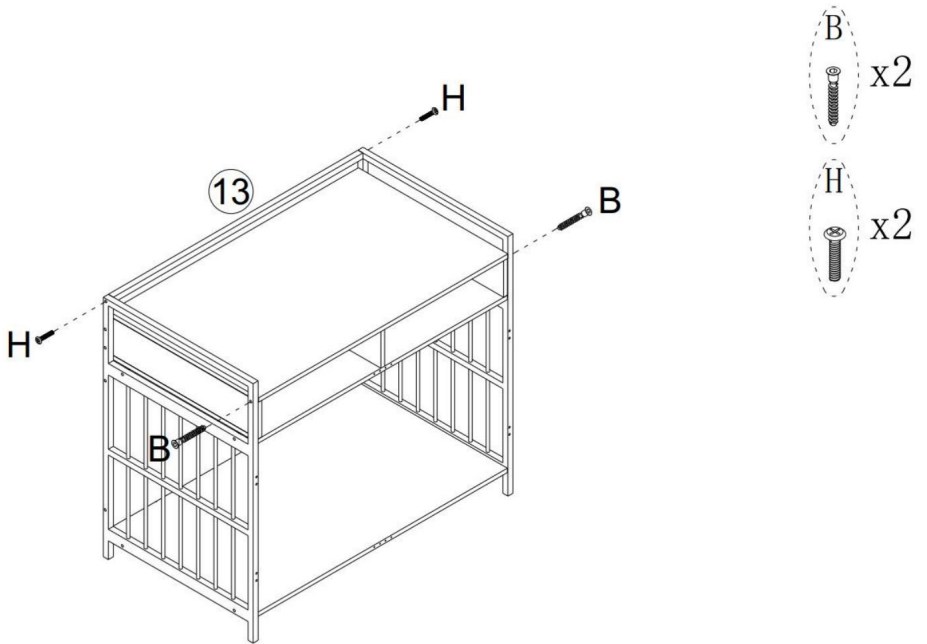

SCHRITT11

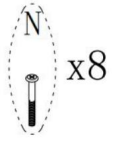
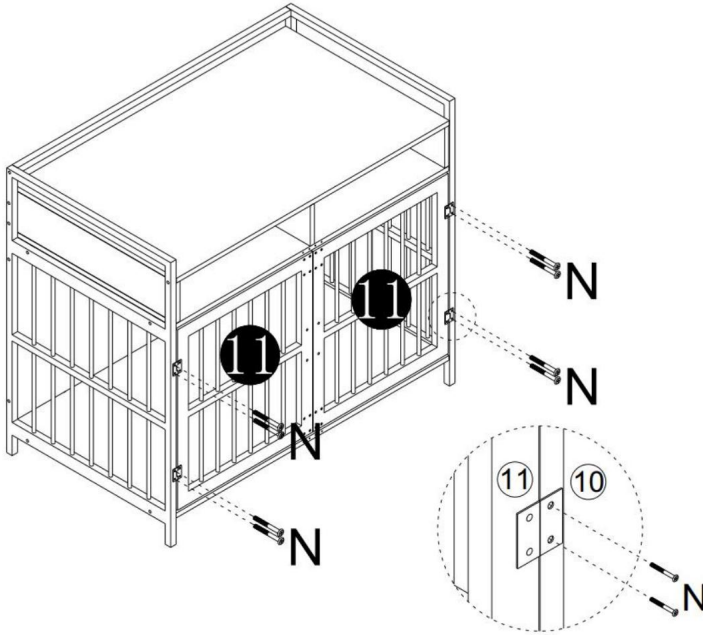

SCHRITT12

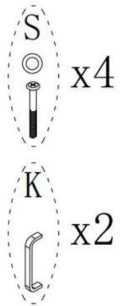
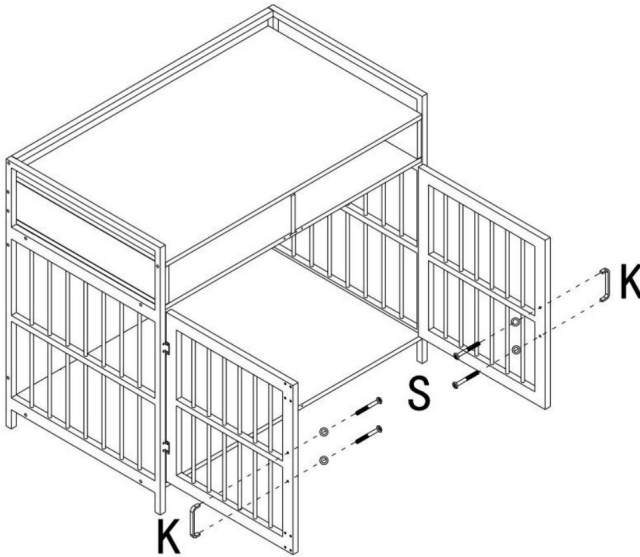

SCHRITT13

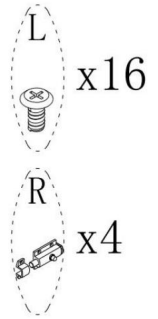
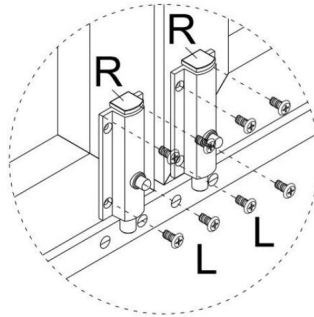
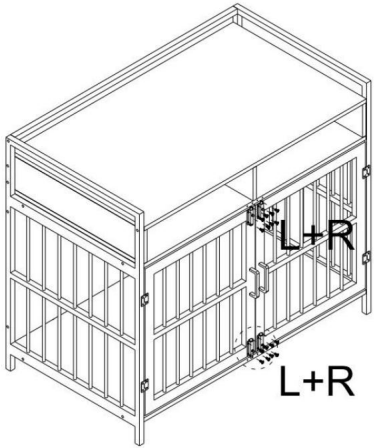

SCHRITT14

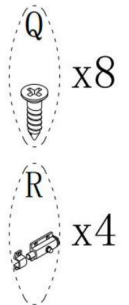
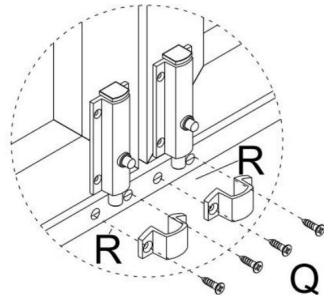
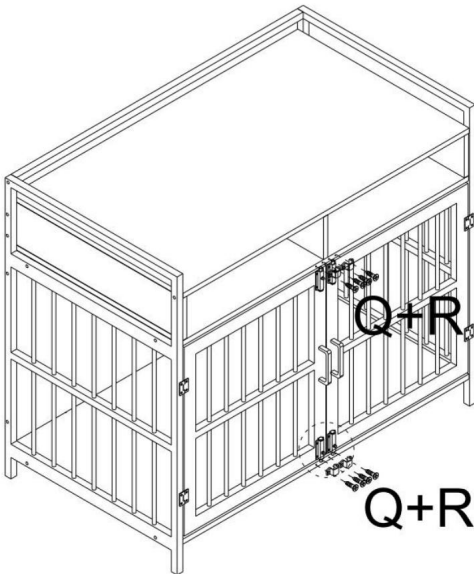

Hinweis: Verriegeln Sie dieses Zubehör, der Riegel klemmt ein wenig. Zum Einbauen drehen Sie das Zubehör bitte.

Hersteller: Shanghaimuxinmuyeyouxiangongsi Adresse:

Shuangchenglu 803nong11hao1602A-1609shi, baoshanqu, Shanghai 200000 CN.

EG-Vertreter: E-CrossStu GmbH.

Mainzer Landstr.69, 60329 Frankfurt am Main.

UK-VERTRETER: YH CONSULTING LIMITED.

C/O YH Consulting Limited Office 147, Centurion House, London Road, Staines-upon-Thames,  
Surrey, TW18 4AX. Importiert nach AUS:

SIHAO PTY LTD.

1 ROKEVA STREETEASTWOOD NSW 2122 Australien

In die USA importiert: Sanven Technology Ltd.

Suite 250, 9166 Anaheim Place, Rancho Cucamonga, CA 91730



**VEVOR<sup>®</sup>**

**TOUGH TOOLS, HALF PRICE**

**Technischer Support und E-Garantie-Zertifikat**

**[www.vevor.com/support](http://www.vevor.com/support)**



# **VEVOR<sup>®</sup>**

## **TOUGH TOOLS, HALF PRICE**

Assistance technique et certificat de garantie électronique [www.vevor.com/support](http://www.vevor.com/support)

### MANUEL D'UTILISATION DE LA CAGE POUR CHIEN

Nous continuons à nous engager à vous fournir des outils à des prix compétitifs.

« Économisez la moitié », « Moitié prix » ou toute autre expression similaire utilisée par nous ne représente qu'une estimation des économies que vous pourriez réaliser en achetant certains outils chez nous par rapport aux grandes marques et ne couvre pas nécessairement toutes les catégories d'outils que nous proposons.

Nous vous rappelons de bien vouloir vérifier soigneusement lorsque vous passez une commande chez nous si vous économisez réellement la moitié par rapport aux grandes marques.



**VEVOR**<sup>®</sup>  
TOUGH TOOLS, HALF PRICE

CAGE POUR CHIEN

Modèle : C20230602W-02

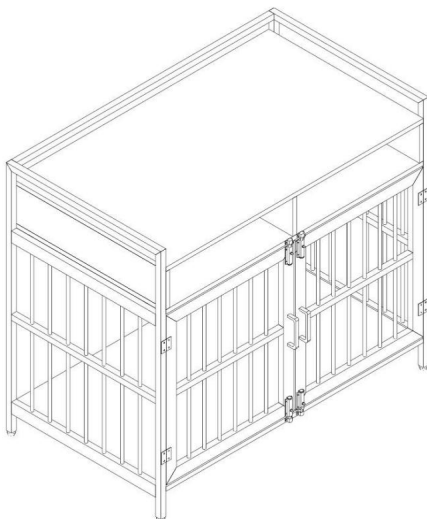

**BESOIN D'AIDE? CONTACTEZ-NOUS!**

Vous avez des questions sur nos produits ? Vous avez besoin d'assistance technique ? N'hésitez pas à nous contacter :

Assistance technique et certificat de garantie  
électronique [www.vevor.com/support](http://www.vevor.com/support)

Il s'agit de la notice d'utilisation d'origine. Veuillez lire attentivement toutes les instructions du manuel avant de l'utiliser. VEVOR se réserve le droit d'interpréter clairement notre manuel d'utilisation. L'apparence du produit dépend du produit que vous avez reçu. Veuillez nous excuser, nous ne vous informerons plus en cas de mise à jour technologique ou logicielle de notre produit.

## AVIS DE SÉCURITÉ

Lisez ce document avant d'utiliser ce produit. Le non-respect de cette consigne peut entraîner de graves conséquences.  
blessure.

### Précautions de montage

1. Assemblez uniquement selon ces instructions. Un assemblage incorrect peut créer dangers.
2. Afin d'assurer votre propre sécurité, assurez-vous d'utiliser des équipements de sécurité approuvés par l'ANSI. des lunettes de protection et des gants de travail robustes lors de l'installation de ce produit.
3. Gardez la zone de montage propre et bien éclairée.
4. Gardez les spectateurs hors de la zone pendant le montage.
5. Ne vous assemblez pas lorsque vous êtes fatigué ou sous l'influence de l'alcool, de drogues ou médicament.
6. Les capacités du produit s'appliquent uniquement aux produits correctement et complètement assemblés.
7. Assembler sur une surface plane, de niveau, dure et lisse capable de supporter en toute sécurité une cage pour chien entièrement chargée.

### Précautions d'emploi

POUR ÉVITER LES BLESSURES GRAVES ET LA MORT RÉSULTANT DU BASCULEMENT :

1. NE PAS S'ASSEOIR, SE TENIR DEBOUT OU MONTER SUR CET ARTICLE.
2. Ce produit n'est pas un jouet. Ne laissez pas les enfants jouer avec ou à proximité de cet article. Veuillez conserver les petites pièces de rechange hors de portée des enfants.
3. Utiliser uniquement sur une surface plane, de niveau, dure et lisse capable de supporter en toute sécurité un cage pour chien entièrement chargée.
4. Utiliser uniquement comme prévu.
5. Inspectez avant chaque utilisation ; ne pas utiliser si des pièces sont desserrées ou endommagées.

## CONSERVEZ CES INSTRUCTIONS

## CARACTÉRISTIQUES

Modèle	C20230602W-02
Taille du produit	41*23,6*36,2 pouces
Couleur	Brun

# COMPOSANTS

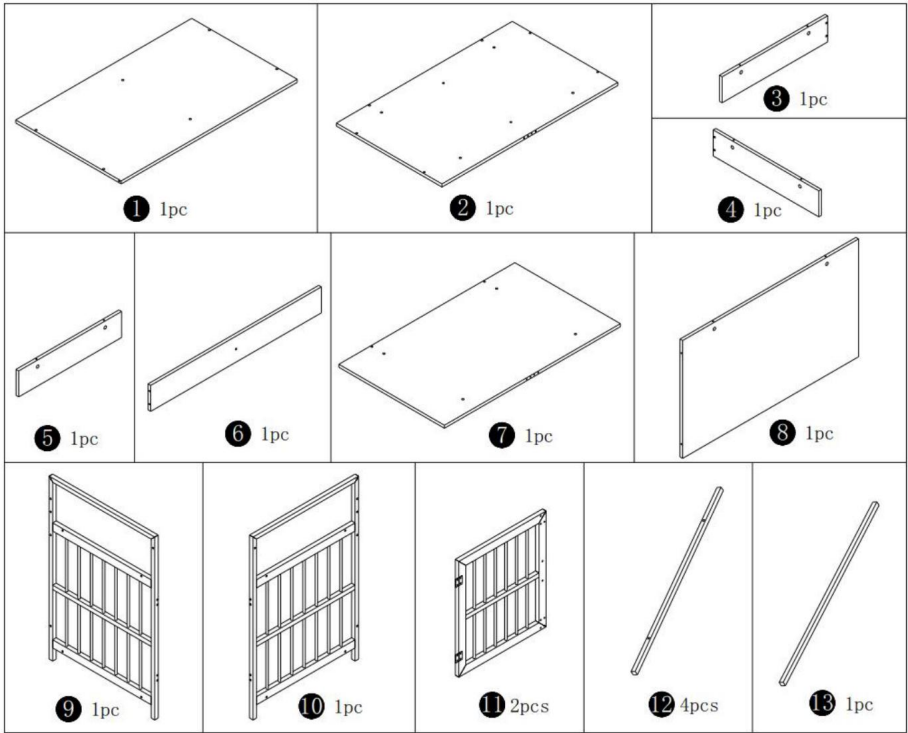

# Instructions de montage

## Installation des cames et des axes

Vissez la goupille dans le trou. Pour régler correctement les cames, assurez-vous que la flèche sur la came s'ouvre pour le trou de la goupille est verrouillé. Verrouillez la came en la tournant fermement. Veuillez ne pas utiliser d'appareil électrique tournevis pour assembler l'unité. la tête de came avec un tournevis jusqu'à ce qu'elle .

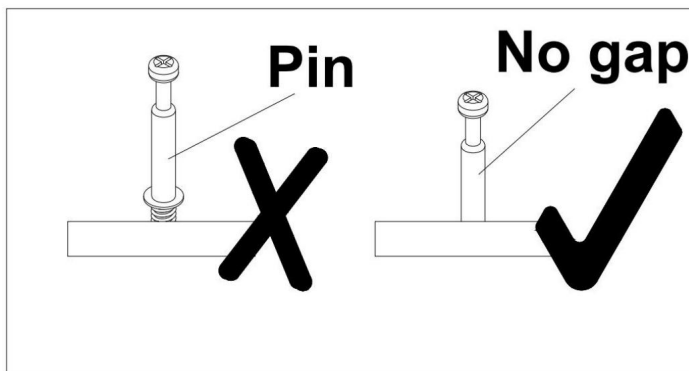
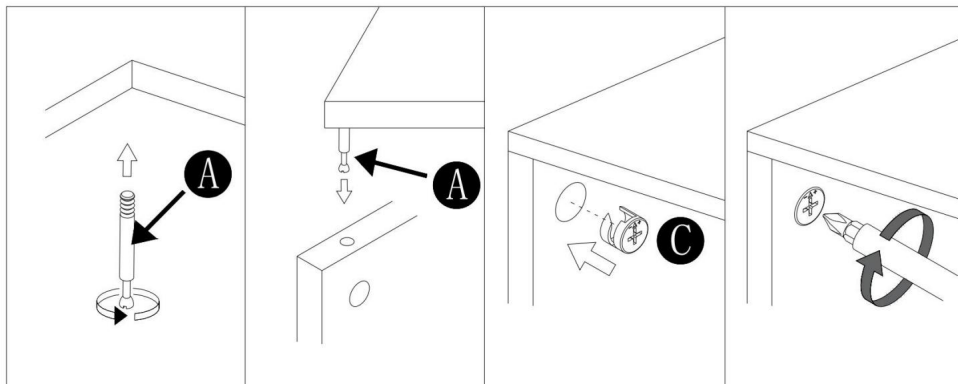

Lisez attentivement chaque étape avant de commencer. Il est très important que chaque étape de l'instruction soit effectuée l'ordre correct. Si ces étapes ne sont pas suivies dans l'ordre, des difficultés d'assemblage surviendront.

ÉTAPE 1

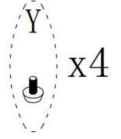
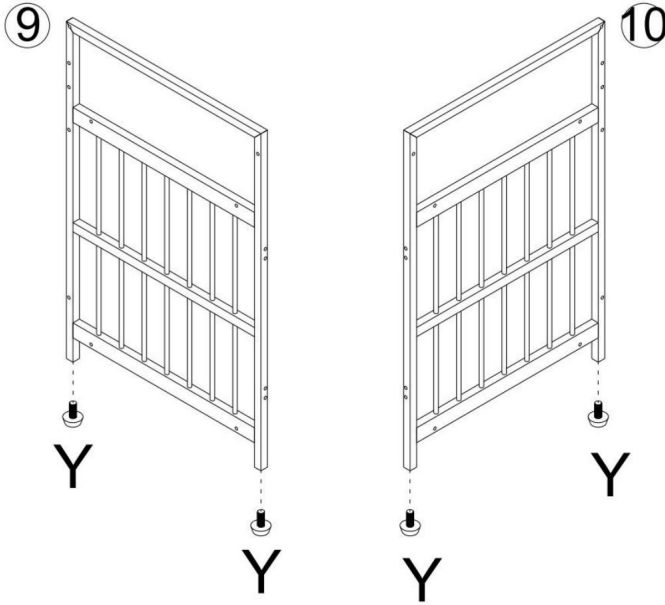

ÉTAPE 2

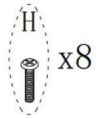
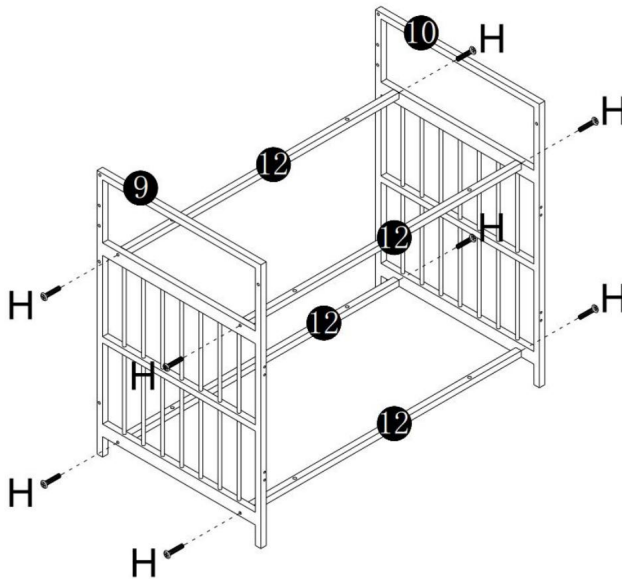

ÉTAPE 3

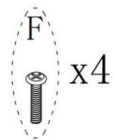
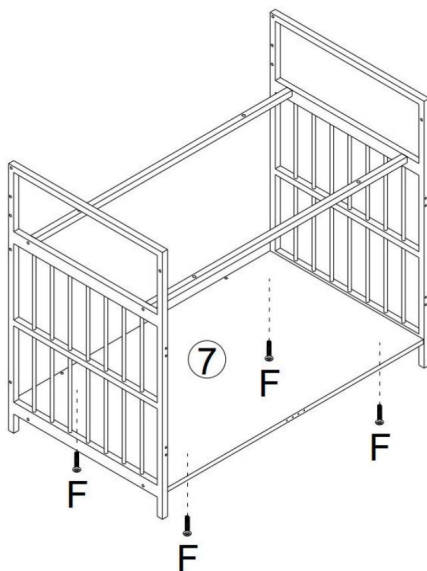

ÉTAPE 4

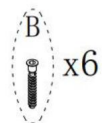
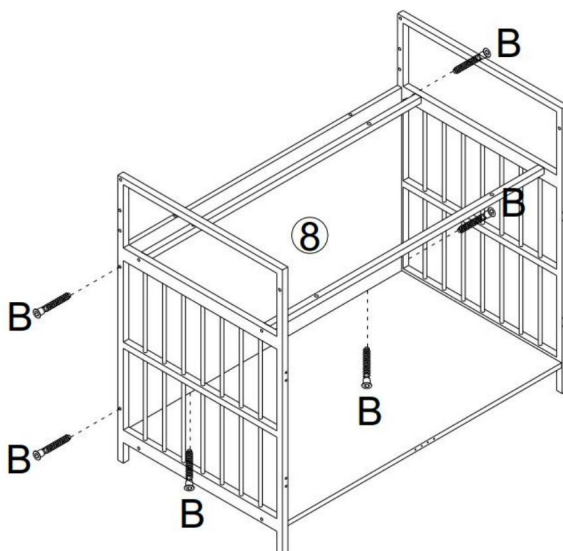



ÉTAPE 5

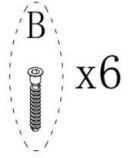
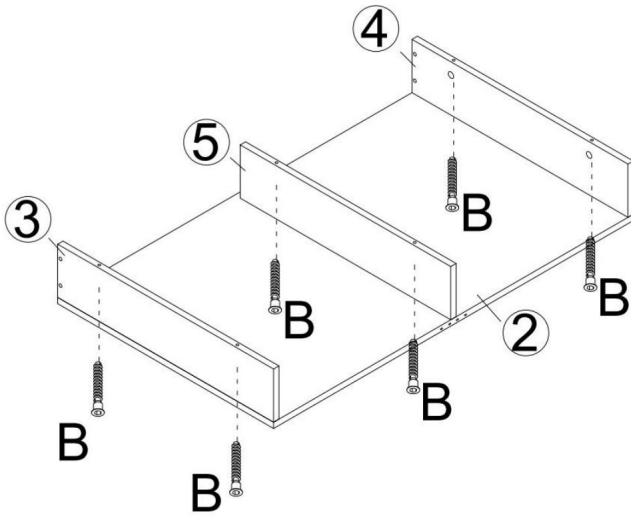

ÉTAPE 6

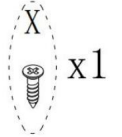
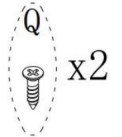
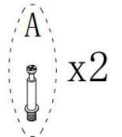
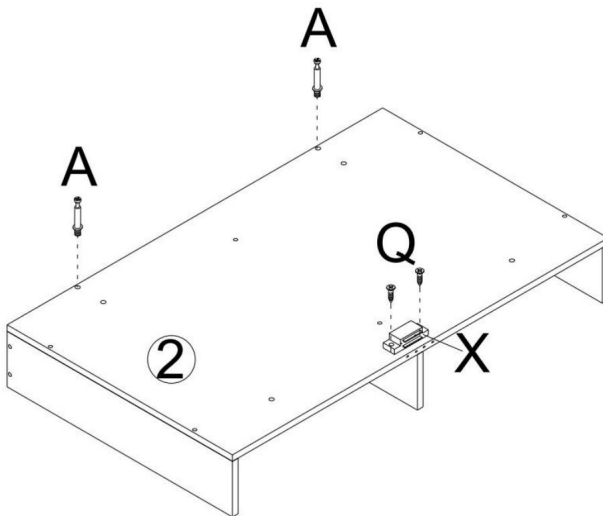

ÉTAPE 7

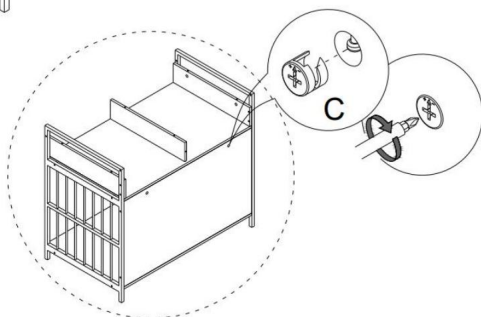
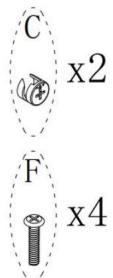
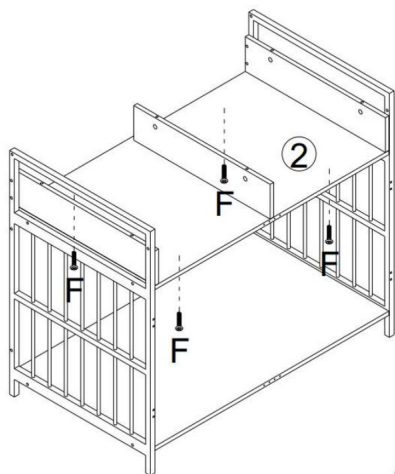

ÉTAPE 8

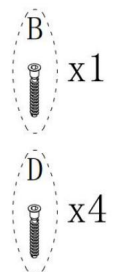
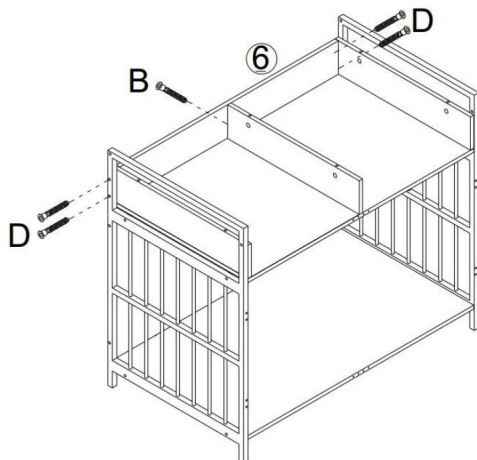

ÉTAPE 9

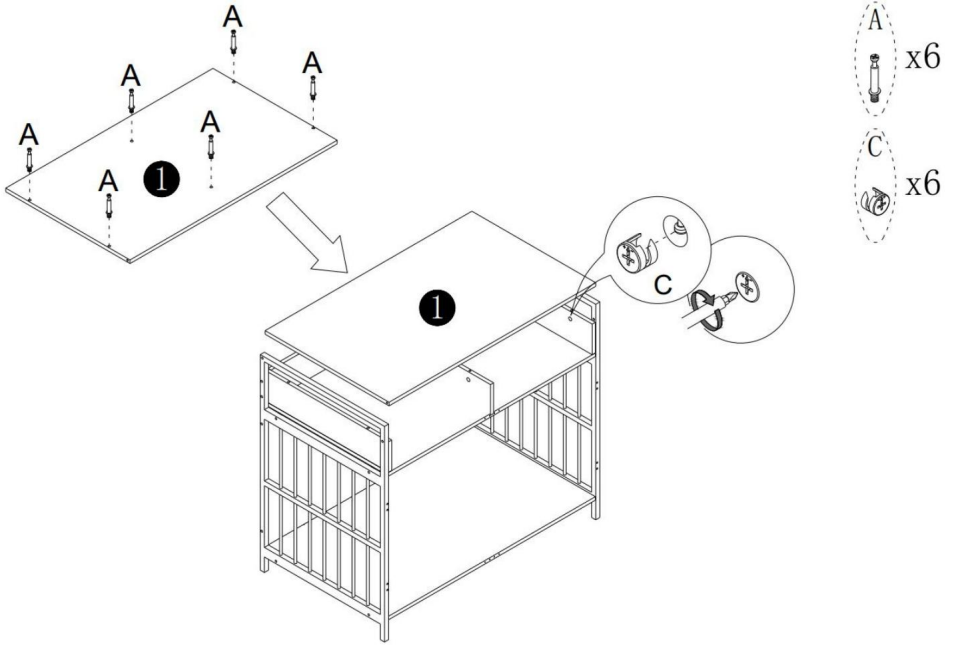

ÉTAPE 10

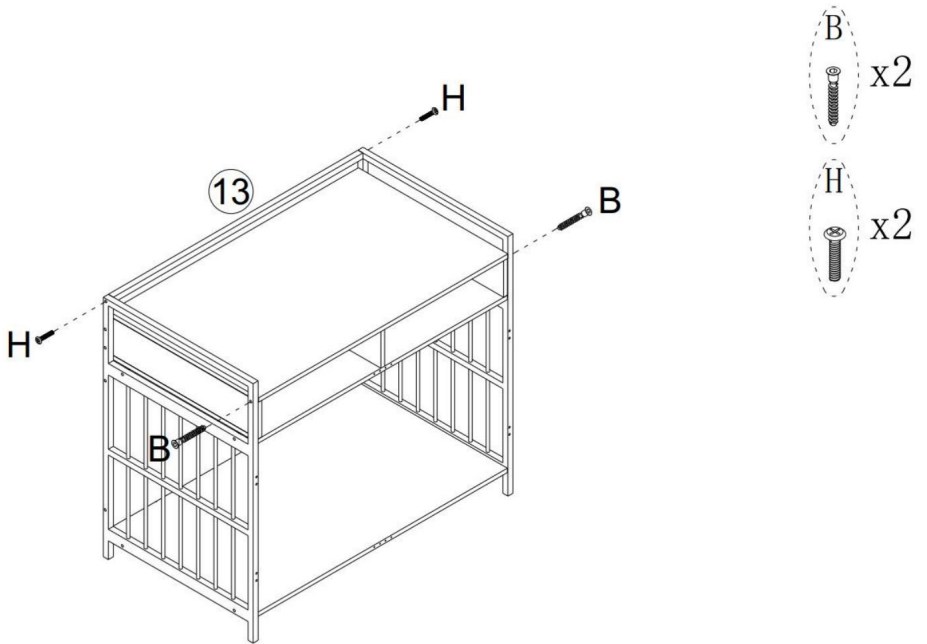

ÉTAPE 11

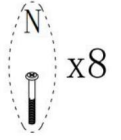
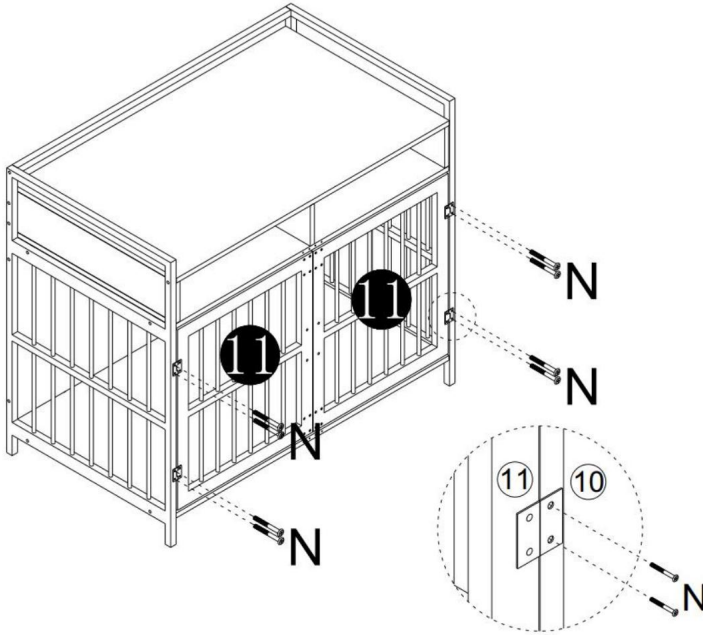

ÉTAPE 12

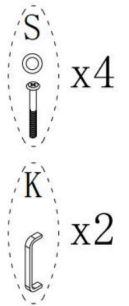
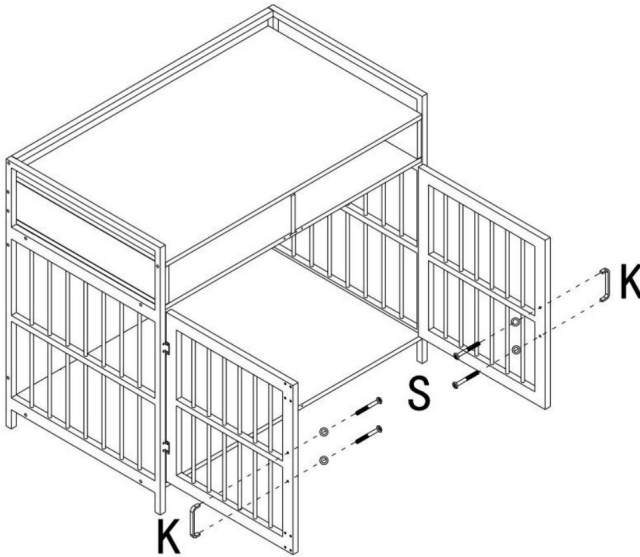

ÉTAPE 13

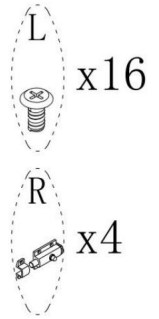
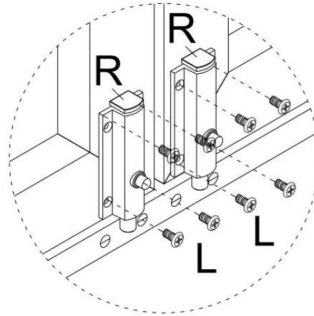
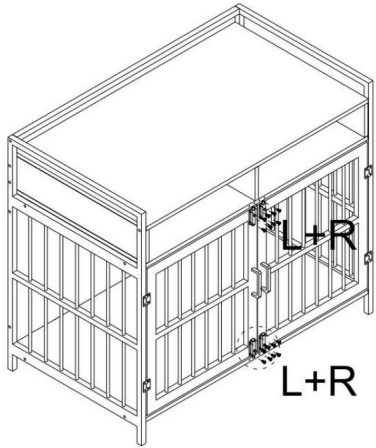

ÉTAPE 14

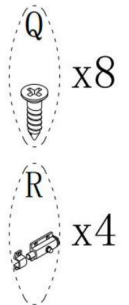
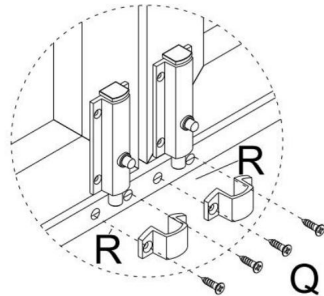
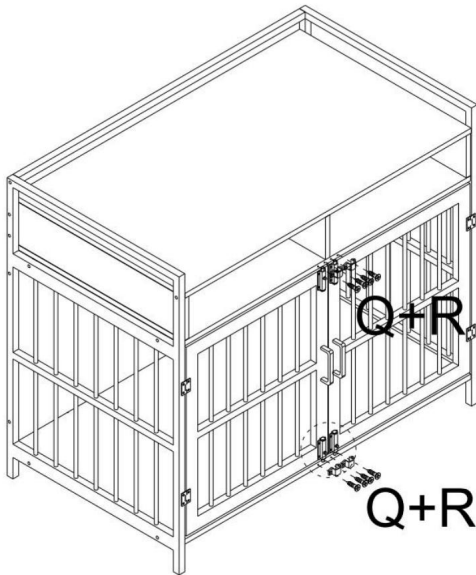

Remarque : verrouillez cet accessoire, le loquet est un peu coincé, veuillez tourner cet accessoire pour l'installer.

Fabricant : Shanghaimuxinmuyeyouxiangongsi Adresse :

Shuangchenglu 803nong11hao1602A-1609shi, baoshanqu, shanghai 200000 CN.

CE REP : E-CrossStu GmbH.

Mainzer Landstr.69, 60329 Francfort-sur-le-Main.

REPRÉSENTANT AU ROYAUME-UNI : YH CONSULTING LIMITED.

C/O YH Consulting Limited Office 147, Centurion House, London Road, Staines-upon-Thames,  
Surrey, TW18 4AX Importé en AUS :

SIHAO PTY LTD.

1 ROKEVA STREET EASTWOOD NSW 2122 Australie

Importé aux États-Unis : Sanven Technology Ltd.

Suite 250, 9166 Anaheim Place, Rancho Cucamonga, CA 91730



**VEVOR<sup>®</sup>**

**TOUGH TOOLS, HALF PRICE**

Assistance technique et certificat de garantie  
électronique [www.vevor.com/support](http://www.vevor.com/support)



# **VEVOR<sup>®</sup>**

## **TOUGH TOOLS, HALF PRICE**

Technische ondersteuning en e-garantiecertificaat [www.vevor.com/support](http://www.vevor.com/support)

### **HONDENKOOI GEBRUIKERSHANDLEIDING**

Wij streven er voortdurend naar om u gereedschappen tegen concurrerende prijzen te leveren.

"Save Half", "Half Price" of andere soortgelijke uitdrukkingen die wij gebruiken, geven alleen een schatting van de besparingen die u kunt behalen door bepaalde gereedschappen bij ons te kopen in vergelijking met de grote topmerken en betekent niet noodzakelijkerwijs dat alle categorieën gereedschappen die wij aanbieden, worden gedekt. Wij

herinneren u eraan om zorgvuldig te controleren of u daadwerkelijk de helft bespaart in vergelijking met de grote topmerken wanneer u een bestelling bij ons plaatst.



**VEVOR**<sup>®</sup>  
TOUGH TOOLS, HALF PRICE

**HONDENKOOI**

Model: C20230602W-02

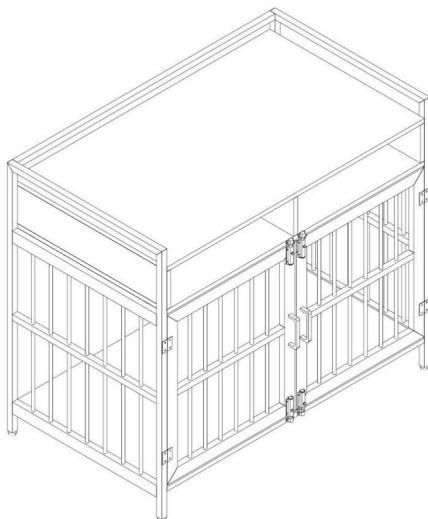

**HULP NODIG? NEEM CONTACT MET ONS OP!**

Heeft u vragen over het product? Heeft u technische ondersteuning nodig? Neem dan gerust contact met ons op:

**Technische ondersteuning en e-  
garantiecertificaat [www.vevor.com/support](http://www.vevor.com/support)**

Dit is de originele instructie, lees alle handleidingen zorgvuldig door voordat u het product gebruikt. VEVOR behoudt zich een duidelijke interpretatie van onze gebruikershandleiding voor. Het uiterlijk van het product is afhankelijk van het product dat u hebt ontvangen. Vergeef ons dat we u niet opnieuw zullen informeren als er technologie- of software-updates voor ons product zijn.

## VEILIGHEIDSINFORMATIE

Lees dit materiaal voordat u dit product gebruikt. Als u dit niet doet, kan dit leiden tot ernstige blessure.

### Voorzorgsmaatregelen bij de montage

1. Monteer alleen volgens deze instructies. Onjuiste montage kan leiden tot gevaren.
2. Om uw eigen veiligheid te garanderen, dient u ervoor te zorgen dat u ANSI-goedgekeurde veiligheidsvoorschriften gebruikt. Draag een veiligheidsbril en stevige werkhandschoenen bij de installatie van dit product.
3. Zorg ervoor dat de verzamelplaats schoon en goed verlicht is.
4. Houd omstanders uit de buurt tijdens de montage.
5. Kom niet bijeen als u moe bent of onder invloed van alcohol, drugs of medicatie.
6. De producteigenschappen gelden alleen voor correct en volledig gemonteerde producten.
7. Monteer op een vlak, egaal, hard en glad oppervlak dat veilig kan worden ondersteund een volgeladen hondenkooi.

### Neem voorzorgsmaatregelen

#### OM ERNSTIG LETSEL EN DE DOOD DOOR KANTELEN TE VOORKOMEN:

1. NIET OP DIT ITEM ZITTEN, STAAN OF KLIMMEN.
2. Dit product is geen speelgoed. Laat kinderen niet met of in de buurt van dit item spelen. Houd kleine reserveonderdelen buiten bereik van kinderen.
3. Gebruik het alleen op een vlak, egaal, hard en glad oppervlak dat veilig een volledig gevulde hondenkooi.
4. Gebruik het product alleen zoals bedoeld.
5. Controleer het apparaat voor elk gebruik. Gebruik het apparaat niet als er onderdelen loszitten of beschadigd zijn.

## BEWAAR DEZE INSTRUCTIES

### SPECIFICATIES

Model	C20230602W-02
Productgrootte	41*23,6*36,2 inch
Kleur	Bruin

# COMPONENTEN

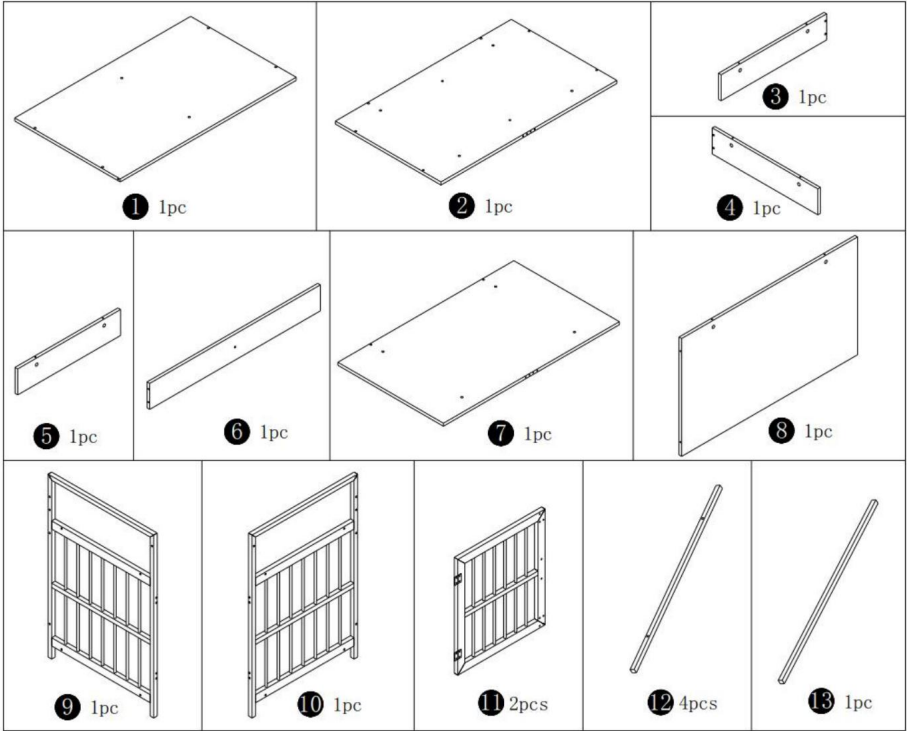

# Montage-instructies

## Installatie van nokken en pennen

Schroef de pen in het gat. Om de nokken correct in te stellen, moet u ervoor zorgen dat de pijl op de nok open is om

het gat van de pen is het vergrendelen. Vergrendel de nok door te draaien vastgedraaid. Gebruik alstublieft geen elektrische schroevendraaier om de unit te monteren. de nokkenaskop met een schroevendraaier totdat deze .

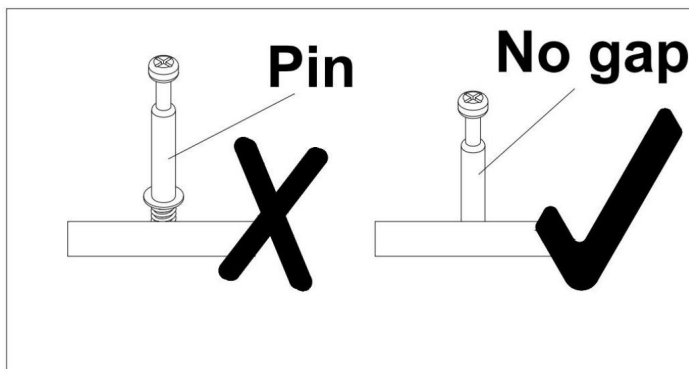
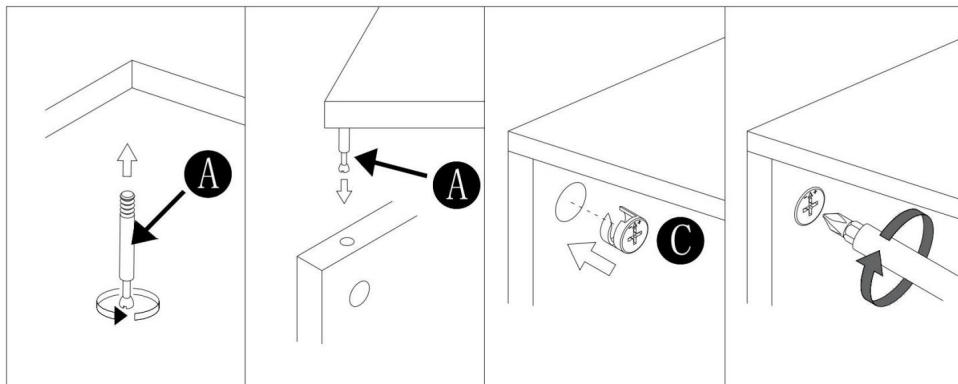

Lees elke stap zorgvuldig door voordat u begint. Het is erg belangrijk dat elke stap van de instructie wordt uitgevoerd in de juiste volgorde. Als deze stappen niet in volgorde worden gevolgd, zullen er montageproblemen optreden.

STAP 1

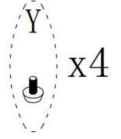
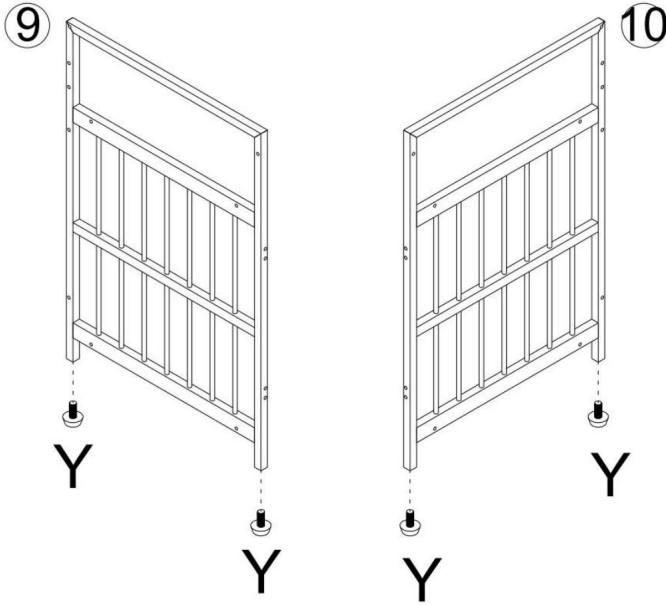

STAP 2

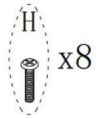
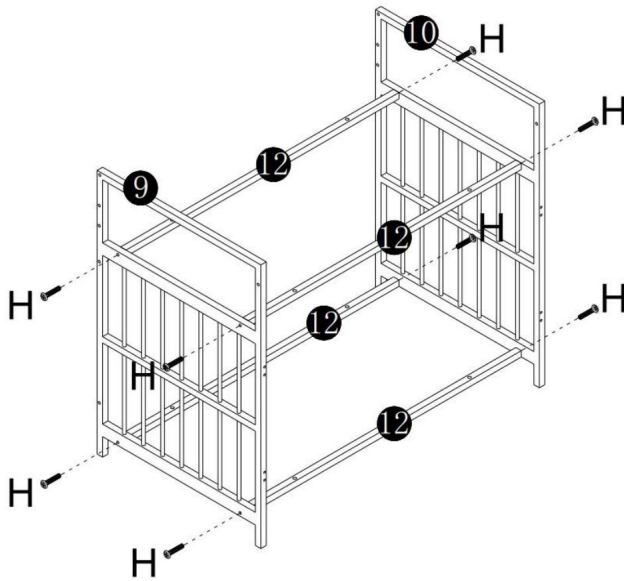

STAP 3

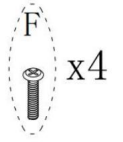
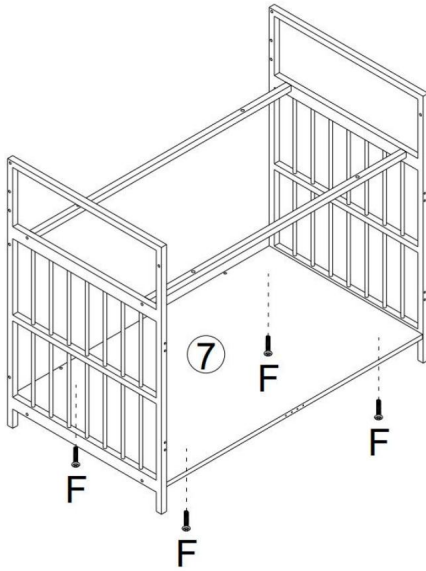

STAP 4

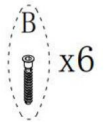
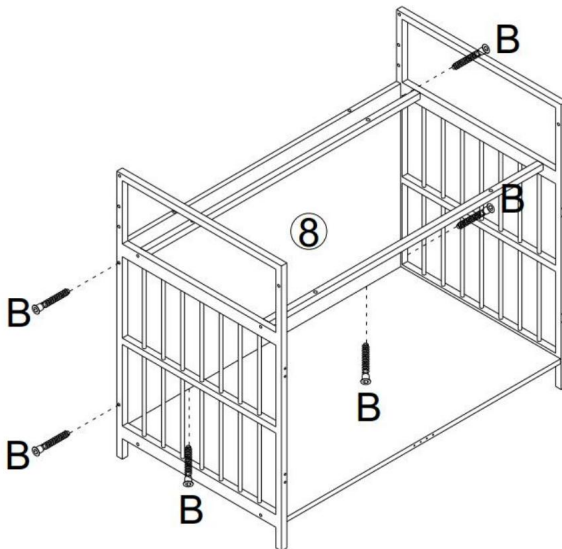



STAP 5

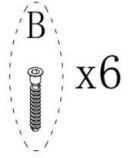
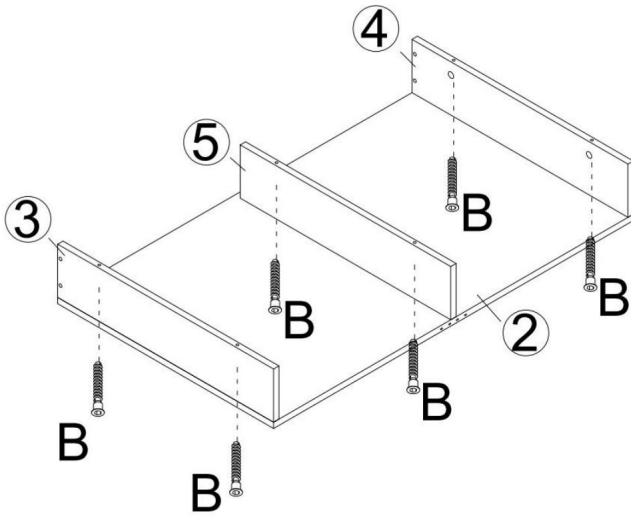

STAP 6

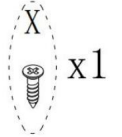
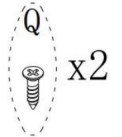
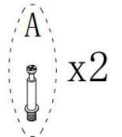
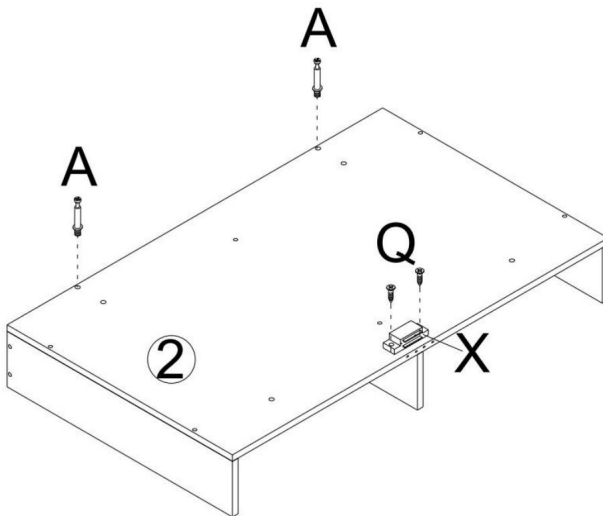

**STAP 7**

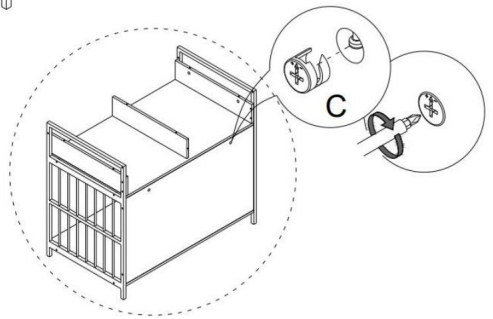
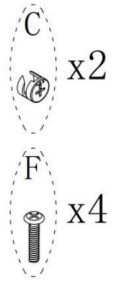
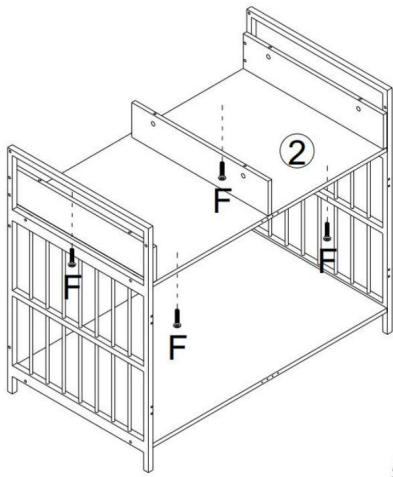

**STAP 8**

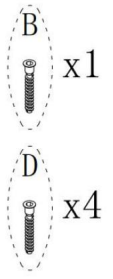
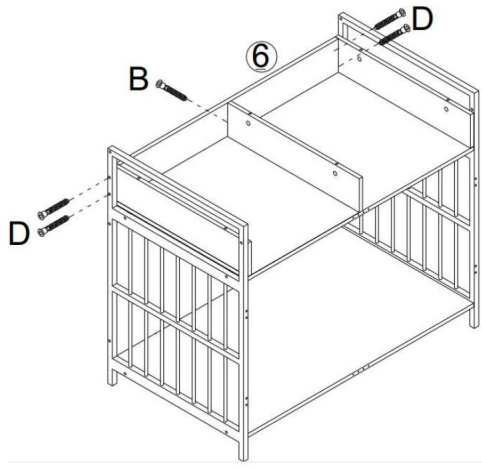

**STAP 9**

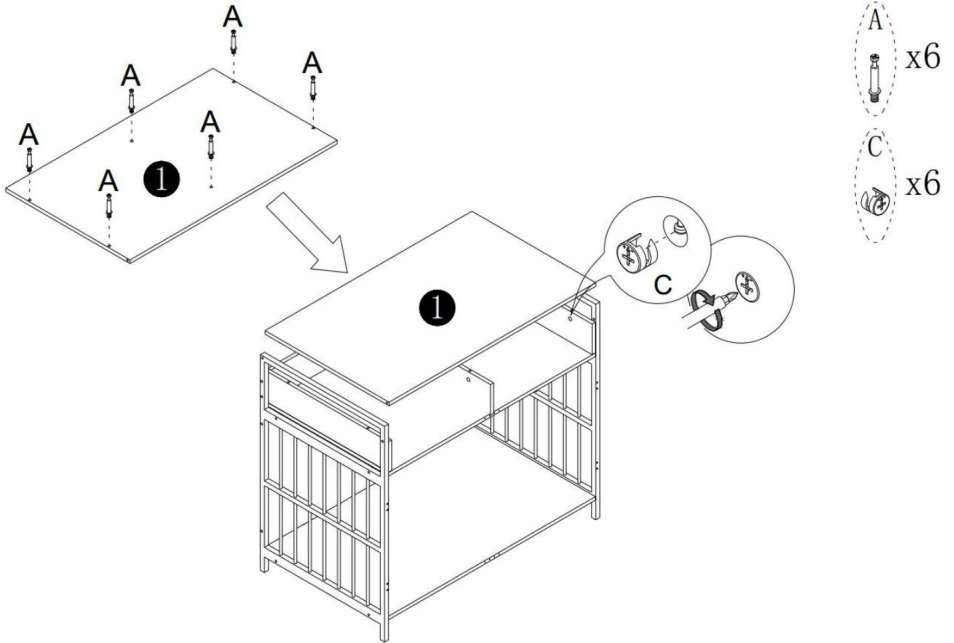

**STAP10**

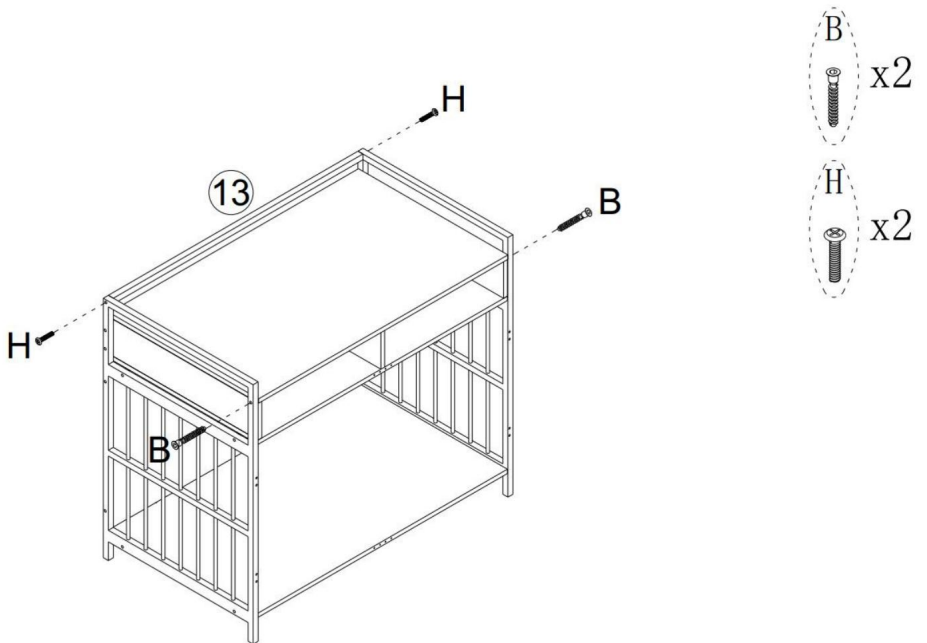

### STAP11

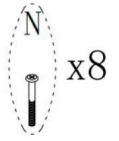
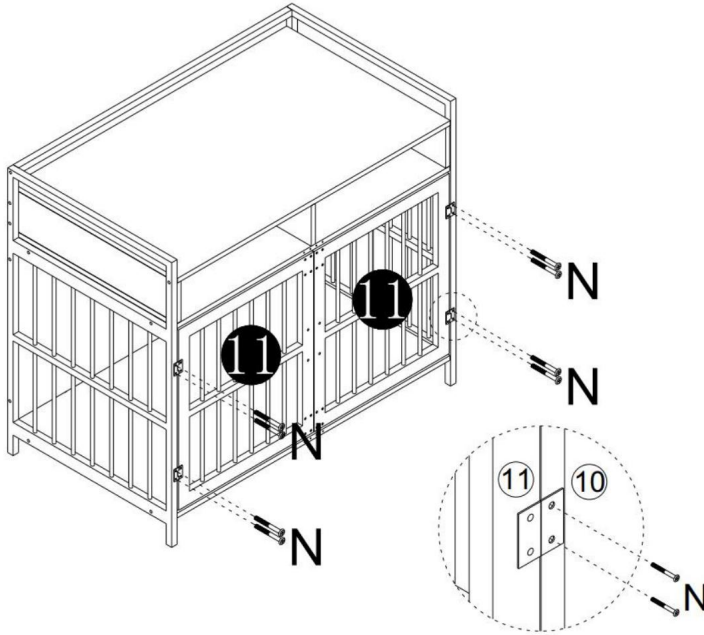

### STAP12

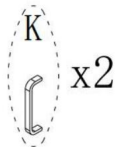
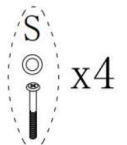
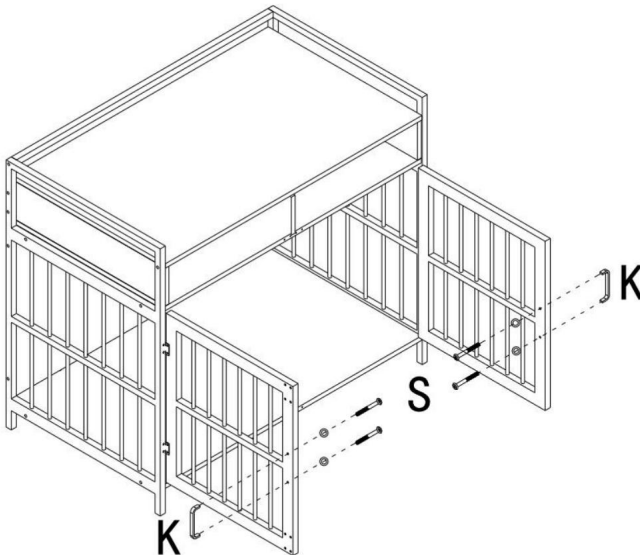

### STAP13

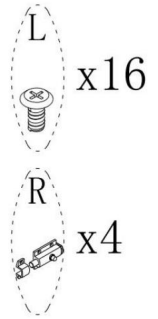
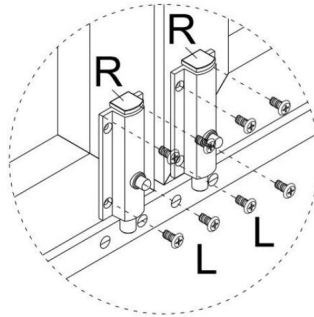
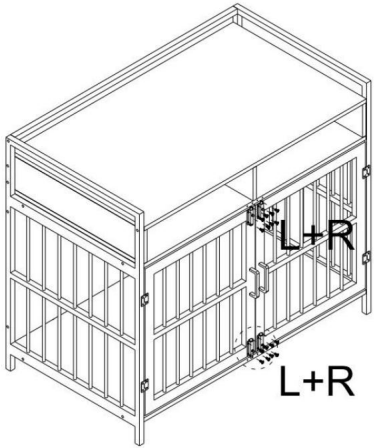

### STAP14

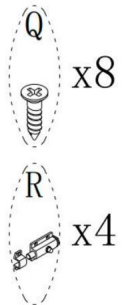
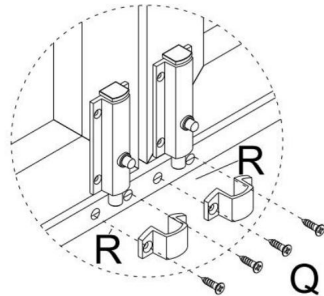
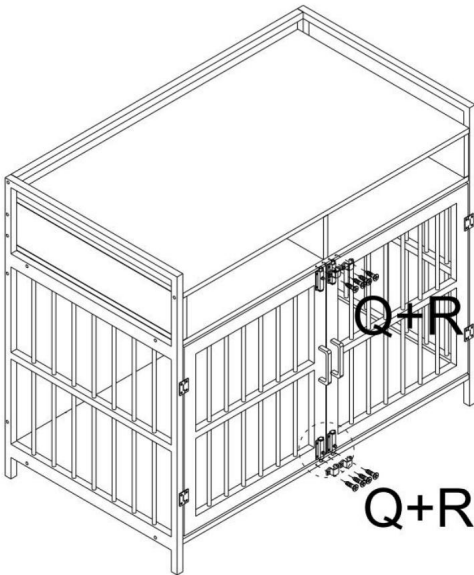

Let op: Vergrendel dit accessoire, de vergrendeling zit een beetje vast, draai het accessoire om het te installeren.

Fabrikant: Shanghaimuxinmuyeyouxiangongsi Adres:

Shuangchenglu 803nong11hao1602A-1609shi, baoshanqu, shanghai 200000 CN.

EG-REP: E-CrossStu GmbH.

Mainzer Landstr.69, 60329 Frankfurt am Main.

VK VERTEGENWOORDIGING: YH CONSULTING LIMITED.

C/O YH Consulting Limited Kantoor 147, Centurion House, London Road, Staines-upon-Thames,  
Surrey, TW18 4AX Geïmporteerd naar

AUS: SIHAO PTY LTD.

1 ROKEVA STRAAT EASTWOOD NSW 2122 Australië

Geïmporteerd naar de VS: Sanven Technology Ltd.

Suite 250, 9166 Anaheim Place, Rancho Cucamonga, CA 91730



**VEVOR**<sup>®</sup>

**TOUGH TOOLS, HALF PRICE**

Technische ondersteuning en e-  
garantiecertificaat [www.vevor.com/support](http://www.vevor.com/support)



# **VEVOR<sup>®</sup>**

## **TOUGH TOOLS, HALF PRICE**

Teknisk support och e-garanticertifikat [www.vevor.com/support](http://www.vevor.com/support)

### **HUNDHÅRD ANVÄNDARHANDBOK**

Vi fortsätter att vara engagerade i att ge dig verktyg till konkurrenskraftiga priser.

"Spara hälften", "halva priset" eller andra liknande uttryck som används av oss representerar bara en uppskattning av besparingar du kan dra nytta av att köpa vissa verktyg hos oss jämfört med de stora toppmärkena och betyder inte nödvändigtvis att täcka alla kategorier av verktyg som erbjuds av oss. Du påminns vänligen om att noggrant kontrollera när du gör en beställning hos oss om du faktiskt sparar hälften i jämförelse med de främsta stora varumärkena.



**VEVOR**<sup>®</sup>  
TOUGH TOOLS, HALF PRICE

HUNDHÅRD

Modell: C20230602W-02

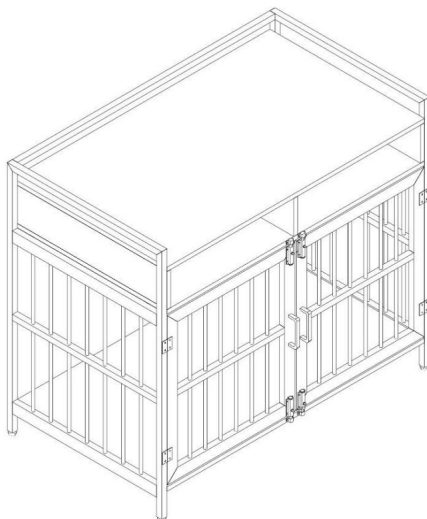

### BEHÖVER HJÄLP? KONTAKTA OSS!

Har du produktfrågor? Behöver du teknisk support? Kontakta oss gärna:

**Teknisk support och e-garanticertifikat**  
**[www.vevor.com/support](http://www.vevor.com/support)**

Detta är den ursprungliga instruktionen, läs alla instruktioner noggrant innan du använder den. VEVOR reserverar sig för en tydlig tolkning av vår användarmanual. Utseendet på produkten är beroende av den produkt du fått. Ursäkta oss att vi inte kommer att informera dig igen om det finns någon teknik eller mjukvaruuppdateringar på vår produkt.

## SÄKERHETSMEDELANDE

Läs detta material innan du använder denna produkt. Underlåtenhet att göra det kan leda till allvarliga konsekvenser skada.

### Försiktighetsåtgärder vid montering

1. Montera endast enligt dessa instruktioner. Felaktig montering kan skapa faror.
2. För att säkerställa din egen säkerhet, se till att ANSI-godkänd säkerhet skyddsglasögon och kraftiga arbetshandskar när du installerar denna produkt.
3. Håll monteringsområdet rent och väl upplyst.
4. Håll åskådare borta från området under monteringen.
5. Montera inte när du är trött eller påverkad av alkohol, droger eller medicin.
6. Produktens egenskaper gäller endast för korrekt och färdigmonterade produkter.
7. Montera på en plan, jämn, hård och slät yta som säkert kan stödja en fullastad hundbur.

### Använd försiktighetsåtgärder

### FÖR ATT FÖRHINDRA ALLVARLIGA SKADA OCH DÖDSFALL VID VÄLLNING:

1. SIT, STÅ ELLER KLÄTTRA INTE PÅ DETTA FÖREMÅL.
2. Denna produkt är inte en leksak. Låt inte barn leka med eller nära detta föremål. Förvara små reservdelar utom räckhåll för barn.
3. Använd endast på en plan, jämn, hård och slät yta som säkert kan stödja en fullastad hundbur.
4. Använd endast på avsett sätt.
5. Inspektera före varje användning; Använd inte om delar är lösa eller skadade.

## SPARA DESSA INSTRUKTIONER

### SPECIFIKATIONER

Modell	C20230602W-02
Produktstorlek	41*23,6*36,2tum
Färg	Brun

# KOMPONENTER

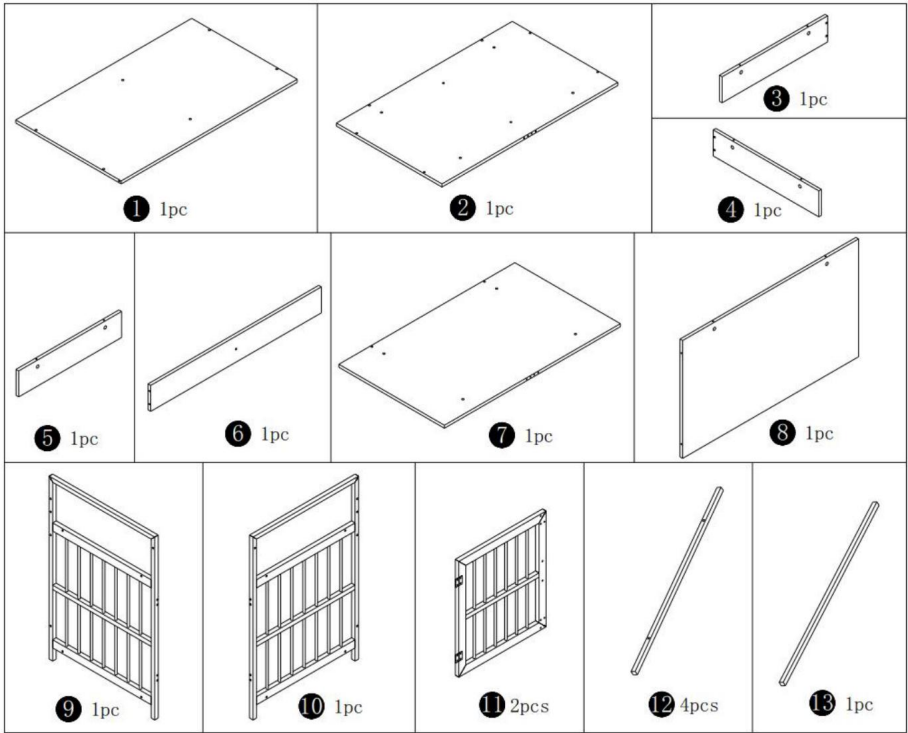

# Monteringsanvisningar

## Installation av kammar och stift

Skruva fast stiftet i hålet. För att ställa in kammarna korrekt, se till att pilen på kammern öppnas mot

hålet på stiftet det låser. Lås kammern genom att vrida åt. Vänligen använd inte en elektrisk

skruvmejsel för att montera enheten. kamhuvudet med en skruvmejsel tills det .

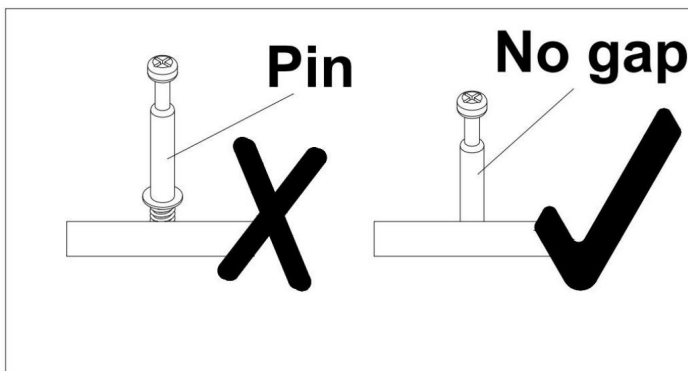
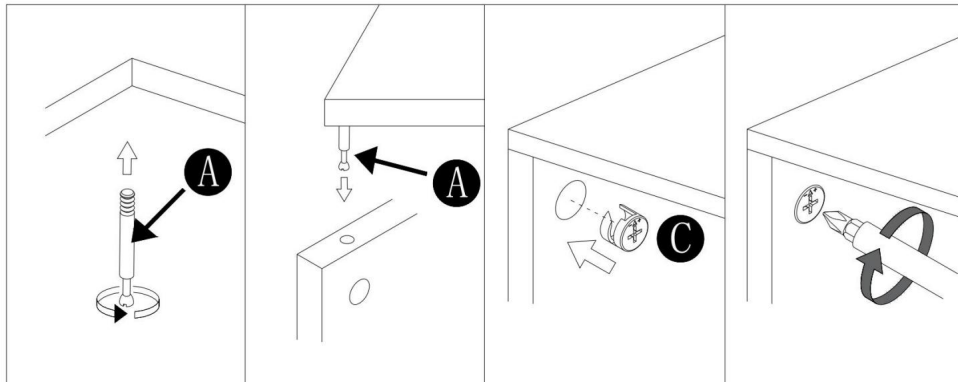

Läs varje steg noggrant innan du börjar. Det är mycket viktigt att varje steg av instruktionen utförs i

rätt ordning. Om dessa steg inte följs i följd kommer monteringsvårigheter att uppstå.

**STEP 1**

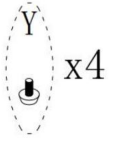
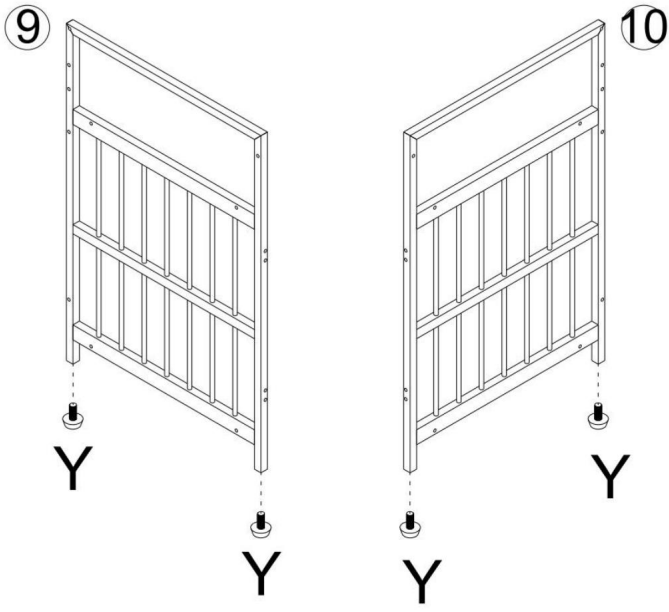

**STEP 2**

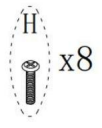
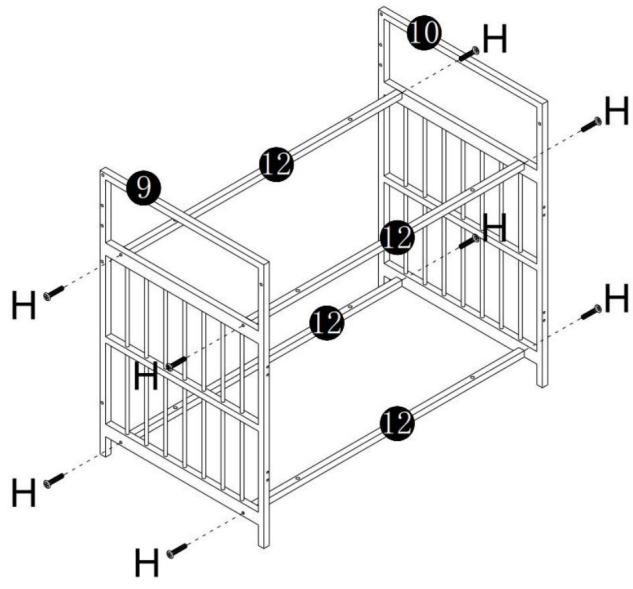

**STEP 3**

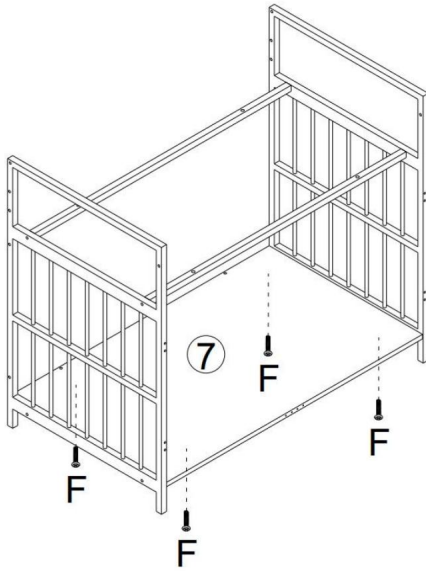
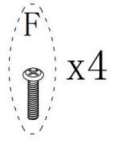

**STEP 4**

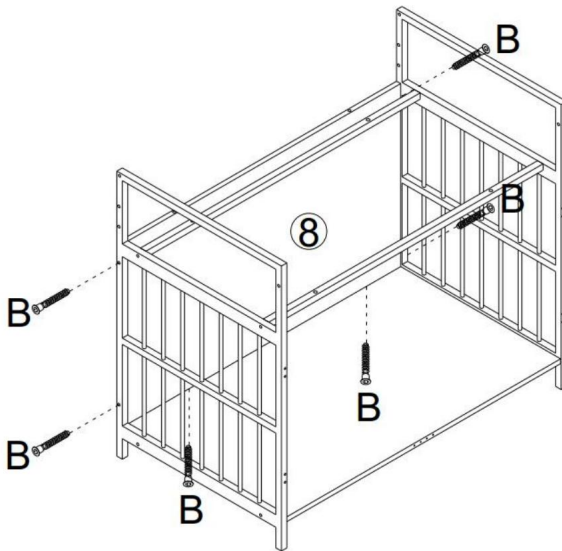
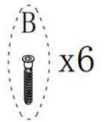



STEP 5

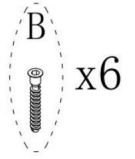
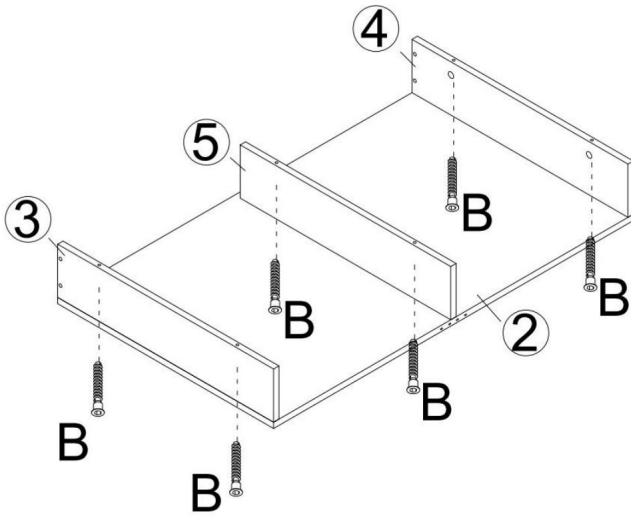

STEP 6

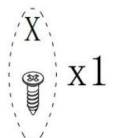
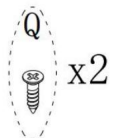
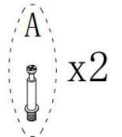
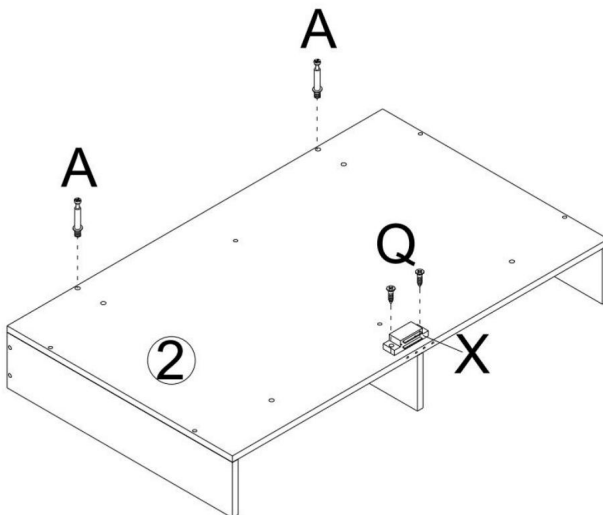

**STEP 7**

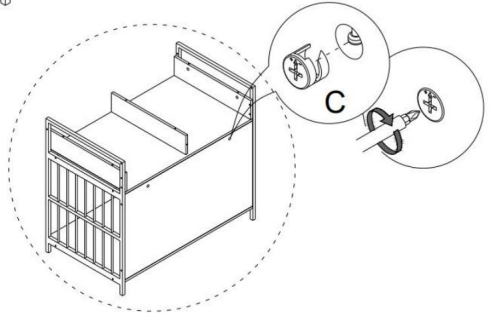
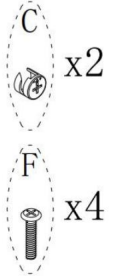
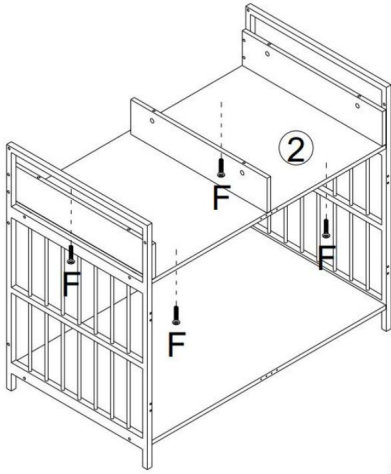

**STEP 8**

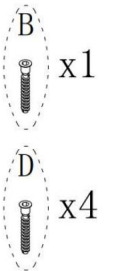
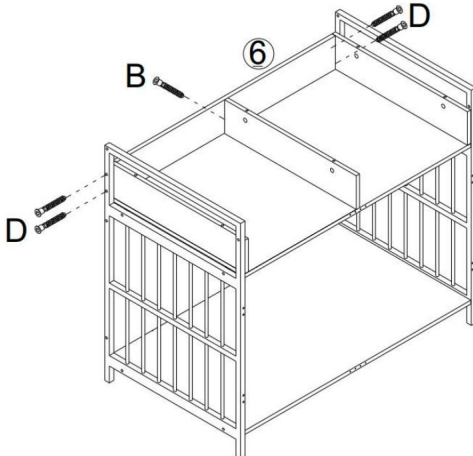

**STEP 9**

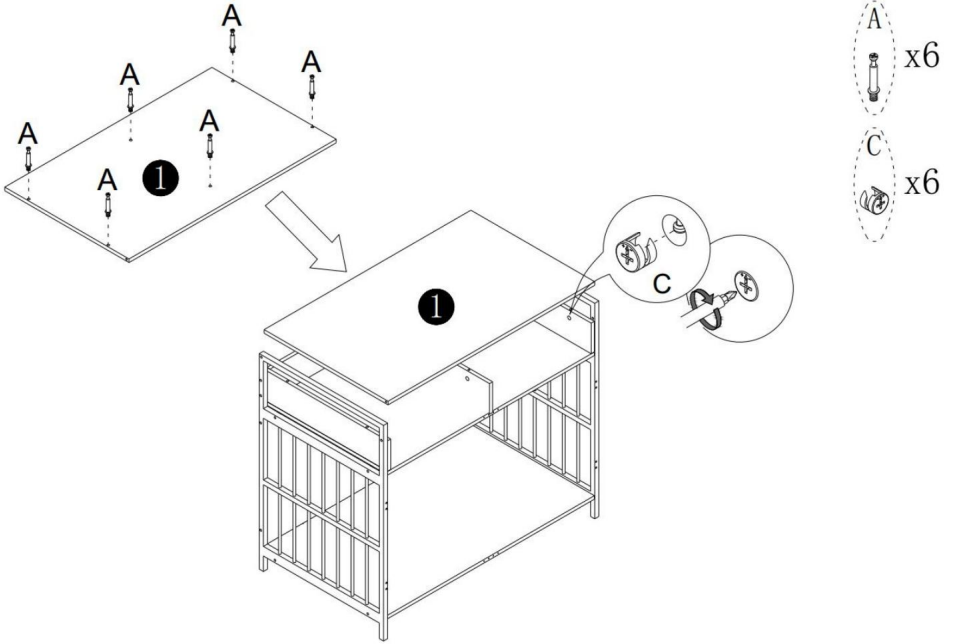

**STEP 10**

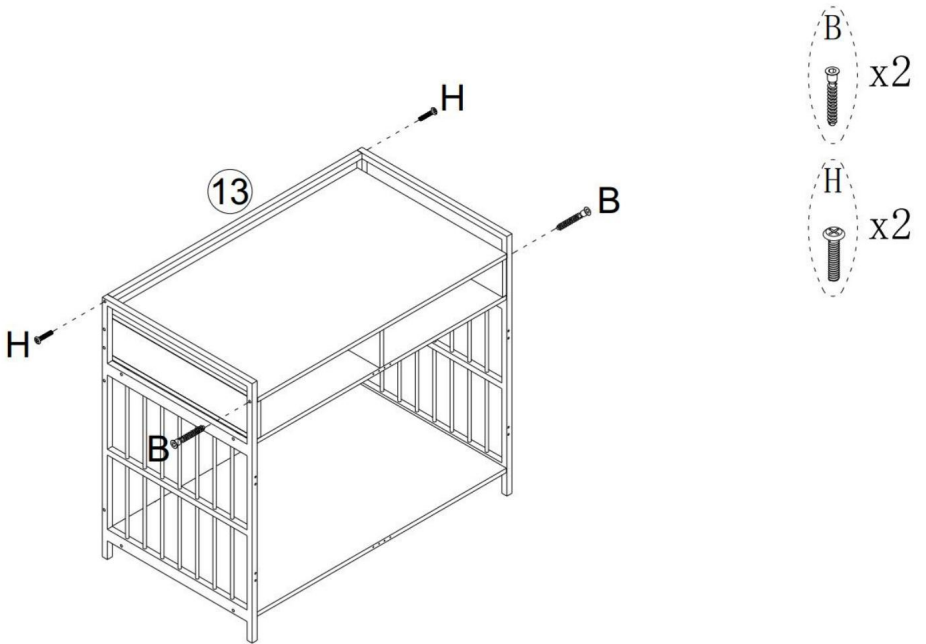

**STEP 11**

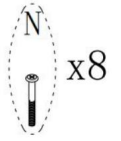
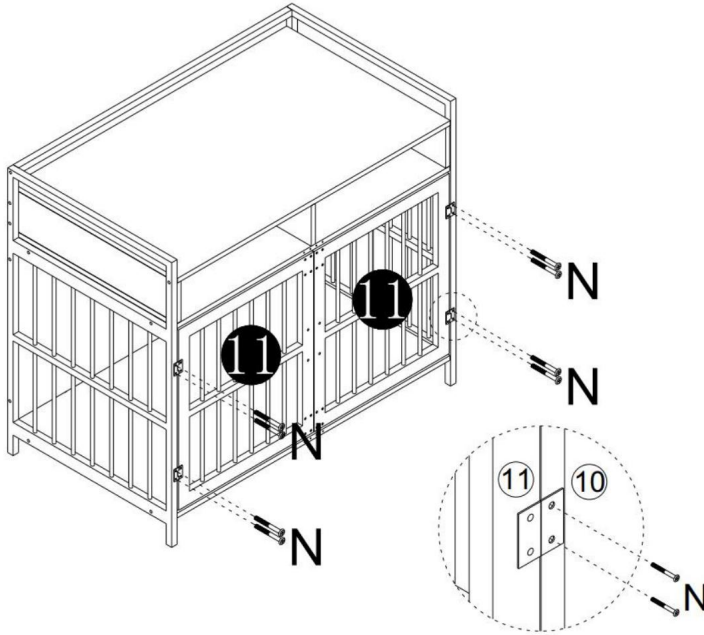

**STEP 12**

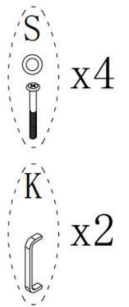
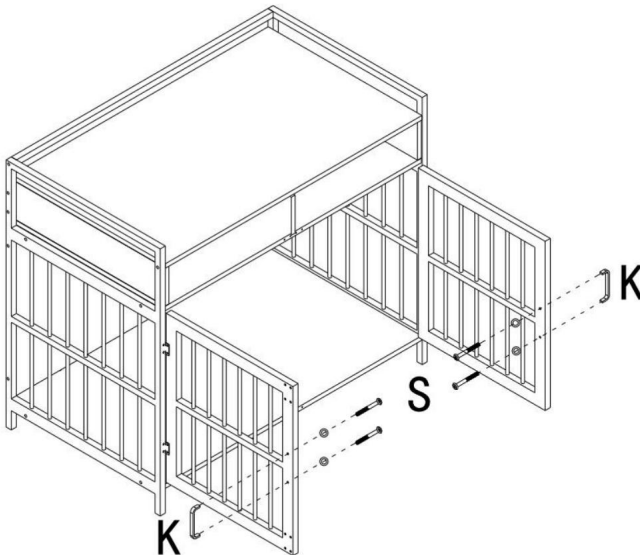

**STEG 13**

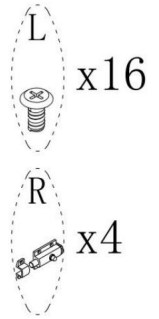
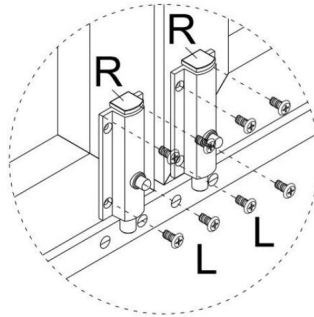
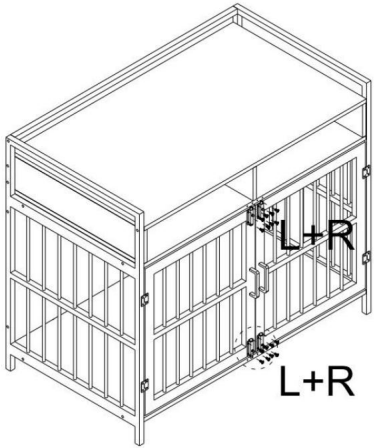

**STEG 14**

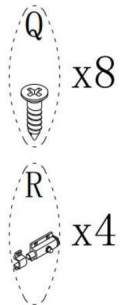
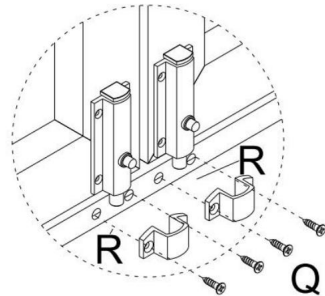
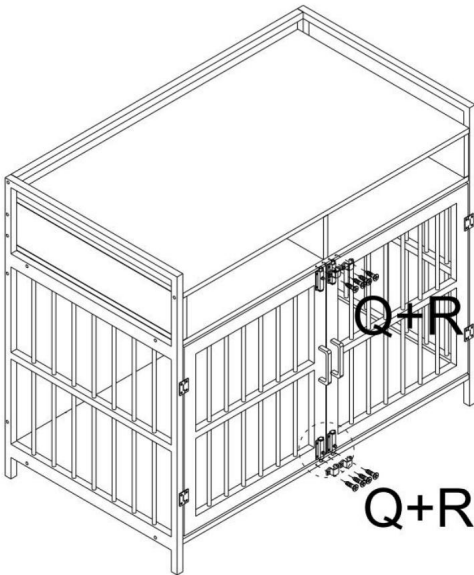

Obs: Lås detta tillbehör, spärren har fastnat lite, vänligen vrid detta tillbehör för att installera.

Tillverkare: Shanghaimuxinmuyeyouxiangongsi Adress:

Shuangchenglu 803nong11hao1602A-1609shi, baoshanqu, shanghai 200000 CN.

EC REP: E-CrossStu GmbH.

Mainzer Landstr.69, 60329 Frankfurt am Main.

UK REP: YH CONSULTING LIMITED.

C/O YH Consulting Limited Office 147, Centurion House, London Road, Staines-upon-Thames,  
Surrey, TW18 4AX Importerad till AUS:

SIHAO PTY LTD.

1 ROKEVA STREETEASTWOOD NSW 2122 Australien

Importerad till USA: Sanven Technology Ltd.

Suite 250, 9166 Anaheim Place, Rancho Cucamonga, CA 91730



**VEVOR**®

**TOUGH TOOLS, HALF PRICE**

**Teknisk support och e-garanticertifikat**

**[www.vevor.com/support](http://www.vevor.com/support)**



# **VEVOR<sup>®</sup>**

## **TOUGH TOOLS, HALF PRICE**

Soporte técnico y certificado de garantía electrónica [www.vevor.com/support](http://www.vevor.com/support)

### MANUAL DEL USUARIO DE LA JAULA PARA PERROS

Seguimos comprometidos a brindarle herramientas a precios competitivos.

"Ahorre la mitad", "mitad de precio" o cualquier otra expresión similar que utilicemos solo representa una estimación del ahorro que podría obtener al comprar ciertas herramientas con nosotros en comparación con las principales marcas y no necesariamente significa que cubra todas las categorías de herramientas que ofrecemos. Le recordamos que, al realizar un pedido con nosotros, verifique cuidadosamente si realmente está ahorrando la mitad en comparación con las principales marcas.



**VEVOR**<sup>®</sup>  
TOUGH TOOLS, HALF PRICE

Jaula para perros

Modelo: C20230602W-02

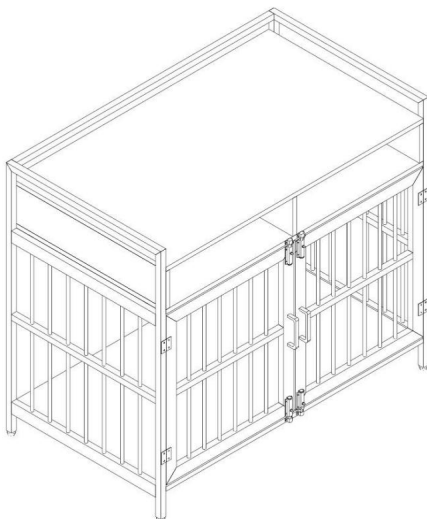

**¿NECESITA AYUDA? ¡CONTÁCTENOS!**

¿Tiene preguntas sobre el producto? ¿Necesita asistencia técnica? No dude en ponerse en contacto con nosotros:

**Soporte técnico y certificado de garantía  
electrónica [www.vevor.com/support](http://www.vevor.com/support)**

Estas son las instrucciones originales, lea atentamente todas las instrucciones del manual antes de utilizar el producto. VEVOR se reserva una interpretación clara de nuestro manual de usuario. La apariencia del producto estará sujeta al producto que recibió. Perdónenos por no informarle nuevamente si hay actualizaciones de tecnología o software en nuestro producto.

## AVISO DE SEGURIDAD

Lea este material antes de utilizar este producto. No hacerlo puede provocar lesiones graves.

lesión.

### Precauciones de montaje

1. Realice el montaje únicamente de acuerdo con estas instrucciones. Un montaje incorrecto puede provocar peligros

2. Para garantizar su propia seguridad, asegúrese de utilizar equipos de seguridad aprobados por ANSI.

Gafas protectoras y guantes de trabajo resistentes al instalar este producto.

3. Mantenga el área de reunión limpia y bien iluminada.

4. Mantenga a los transeúntes fuera del área durante el montaje.

5. No se reúna cuando esté cansado o bajo la influencia del alcohol, drogas o medicamento.

6. Las capacidades del producto se aplican únicamente a productos ensamblados de forma correcta y completa.

7. Ensamble sobre una superficie plana, nivelada, dura y lisa capaz de soportar de forma segura

Una jaula para perros completamente cargada.

Tome precauciones

PARA EVITAR LESIONES GRAVES Y LA MUERTE POR VUELCO:

1. NO SE SIENTA, SE PARE NI SE SUBA SOBRE ESTE ARTÍCULO.

2. Este producto no es un juguete. No permita que los niños jueguen con este artículo ni cerca de él.

Mantenga las piezas de repuesto pequeñas fuera del alcance de los niños.

3. Utilícelo únicamente sobre una superficie plana, nivelada, dura y lisa capaz de soportar de forma segura un peso de 100 kg.

Jaula para perros completamente cargada.

4. Utilícelo únicamente según lo previsto.

5. Inspeccione antes de cada uso; no utilice si las piezas están sueltas o dañadas.

## GUARDE ESTAS INSTRUCCIONES

## PRESUPUESTO

Modelo	C20230602W-02
Tamaño del producto	41*23,6*36,2 pulgadas
Color	Marrón

# COMPONENTES

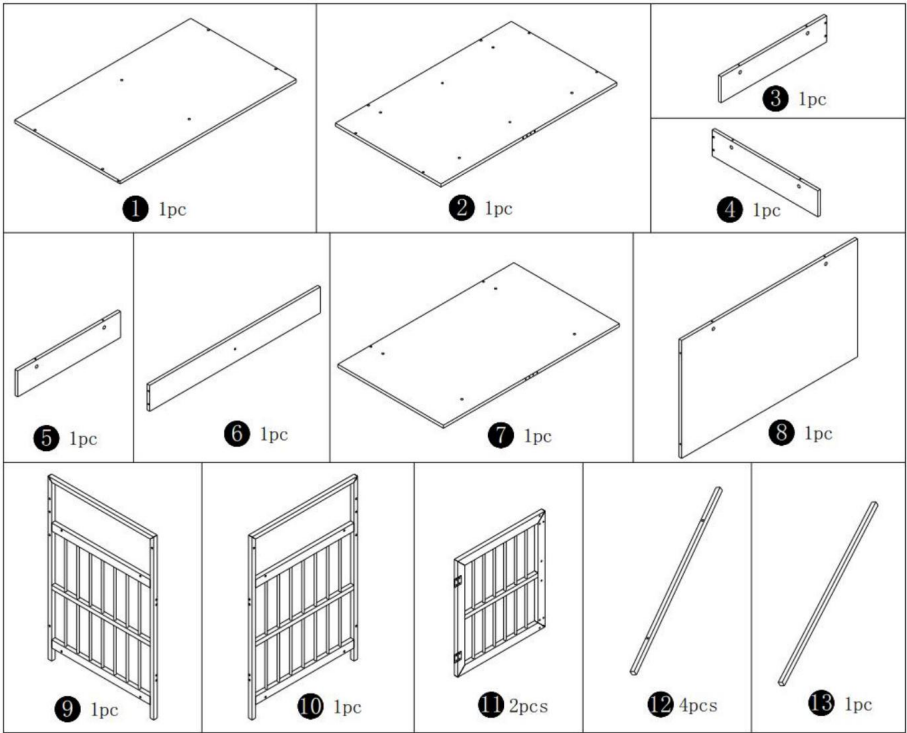

# Instrucciones de montaje

## Instalación de levas y pasadores

Atornille el pasador en el orificio. Para colocar las levas correctamente, asegúrese de que la flecha de la leva esté abierta hacia

El orificio del pasador está bloqueado. Bloquee la leva girándola y apretándola. No utilice un dispositivo eléctrico.

destornillador para ensamblar la unidad. la cabeza de la leva con un destornillador hasta que .

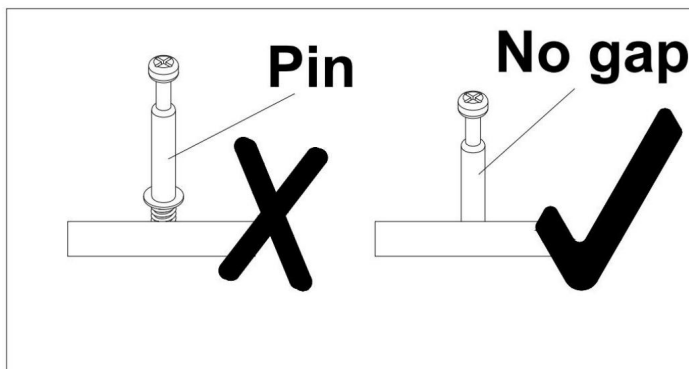
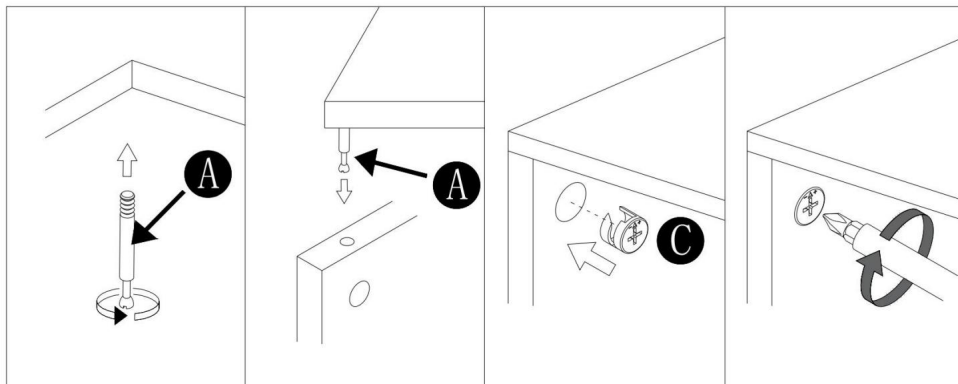

Lea cada paso con atención antes de comenzar. Es muy importante que cada paso de las instrucciones se realice de acuerdo con las instrucciones.

el orden correcto. Si no se siguen estos pasos en secuencia, surgirán dificultades de montaje.

PASO 1

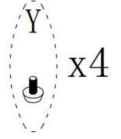
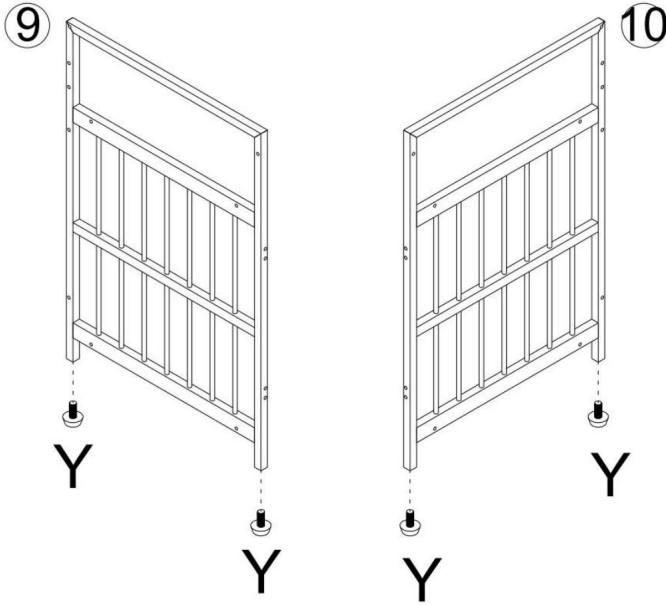

PASO 2

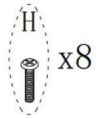
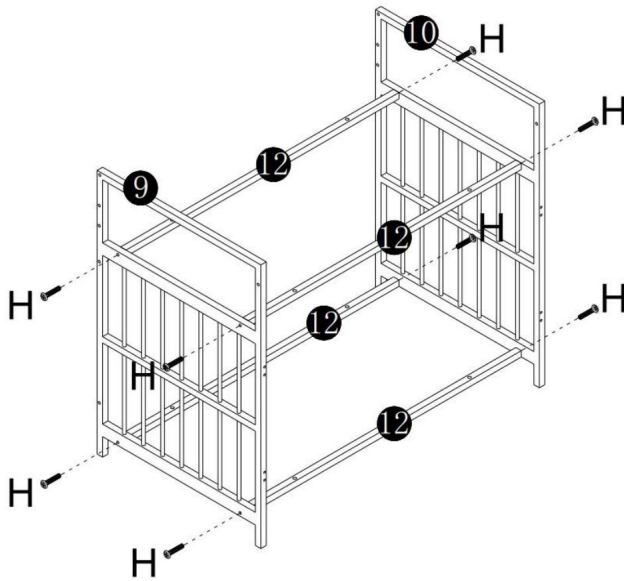

PASO 3

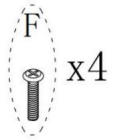
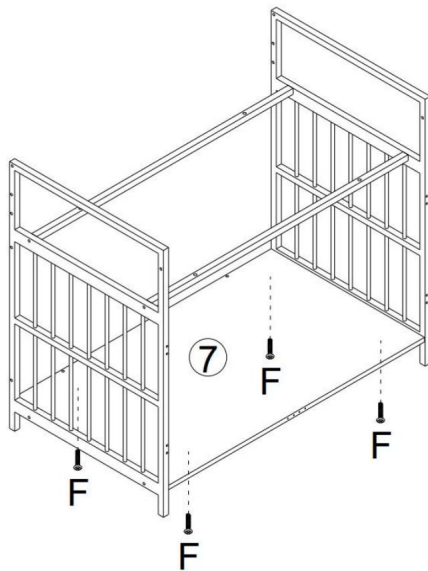

PASO 4

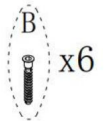
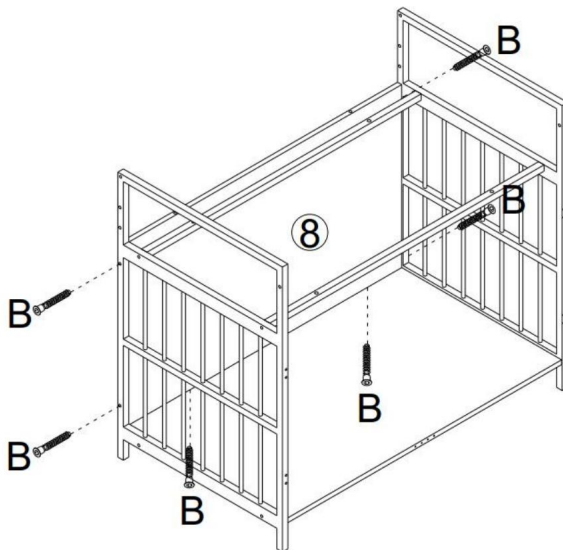



PASO 5

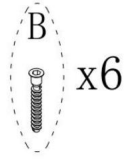
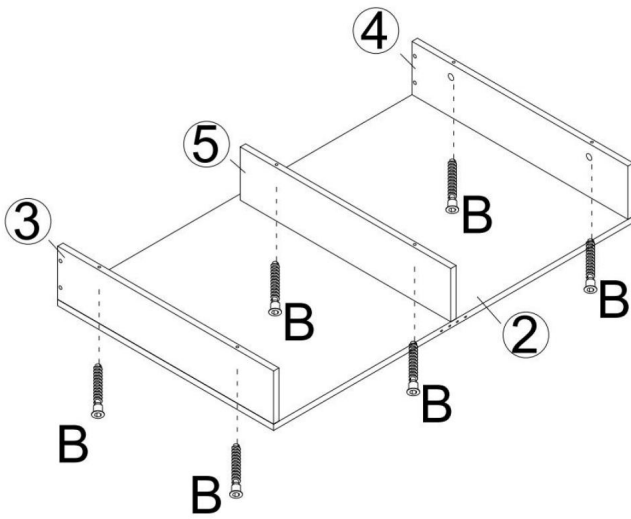

PASO 6

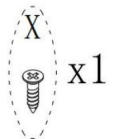
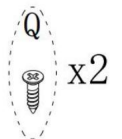
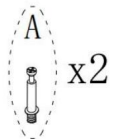
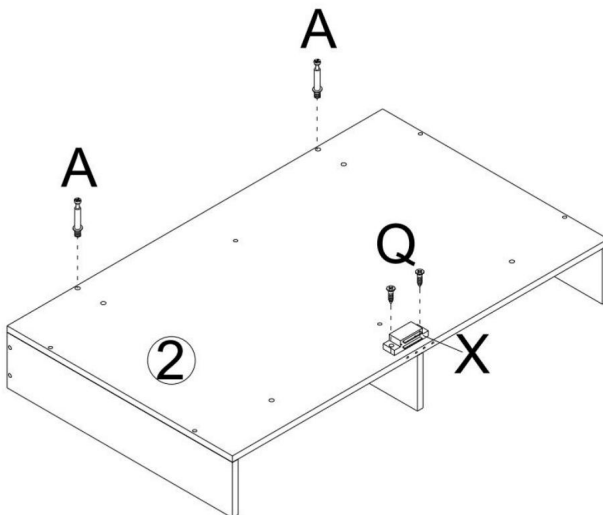

PASO 7

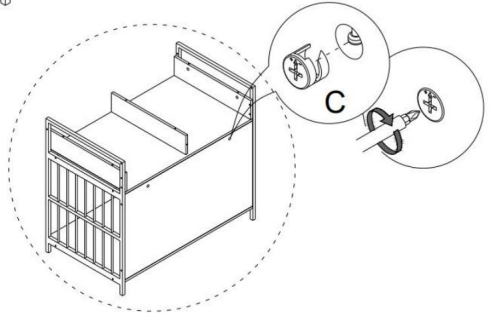
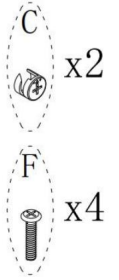
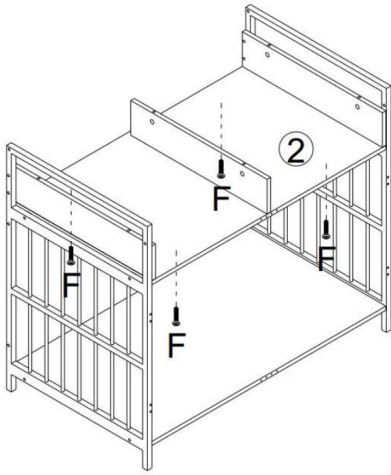

PASO 8

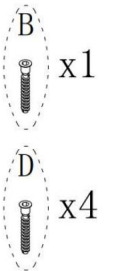
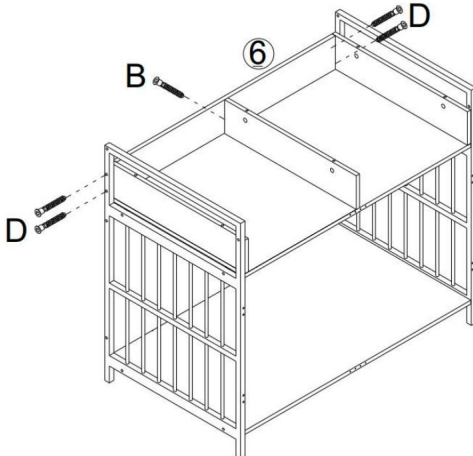

PASO 9

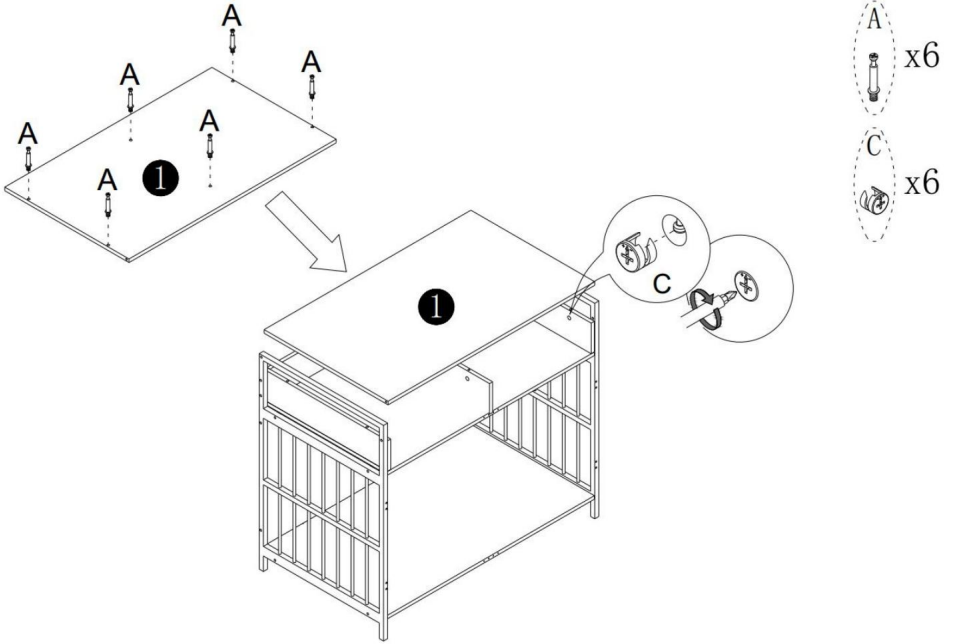

PASO 10

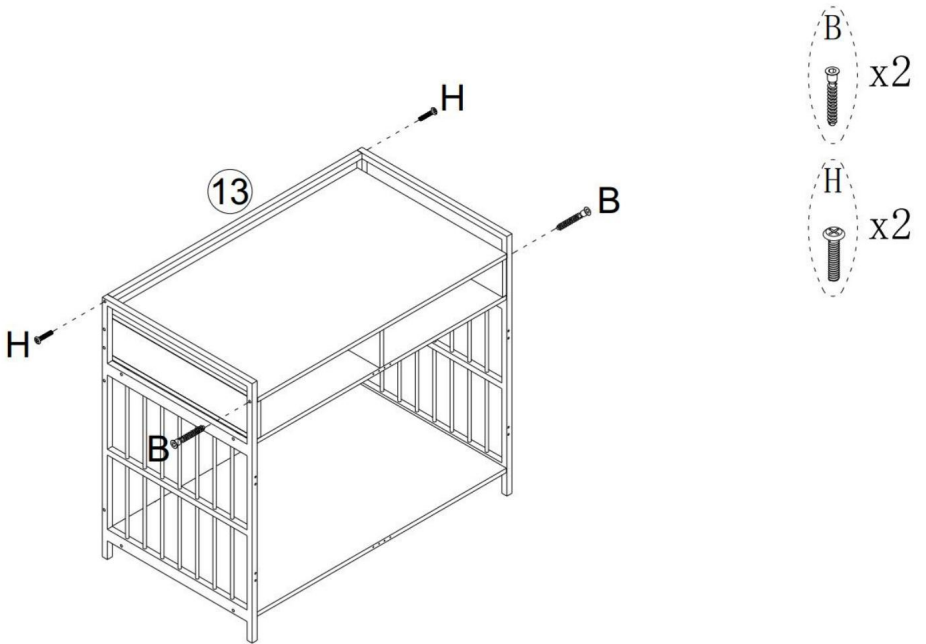

PASO 11

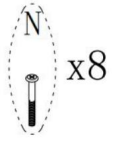
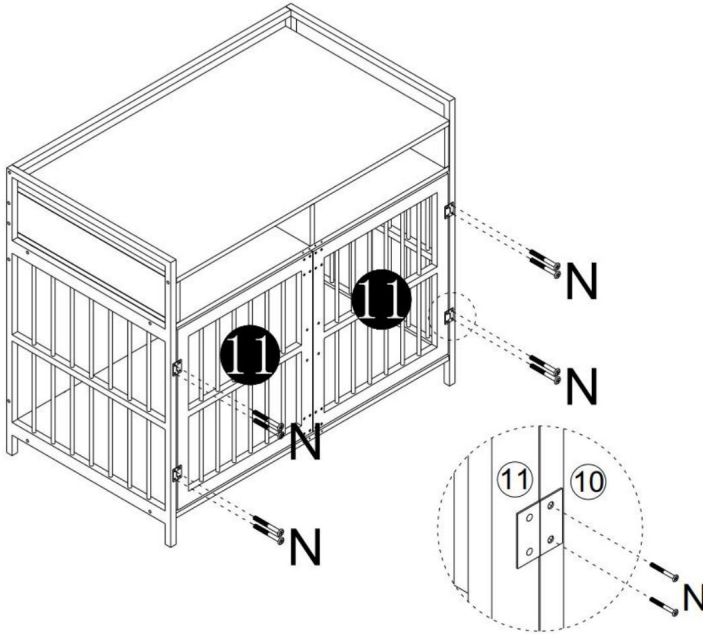

PASO 12

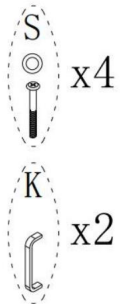
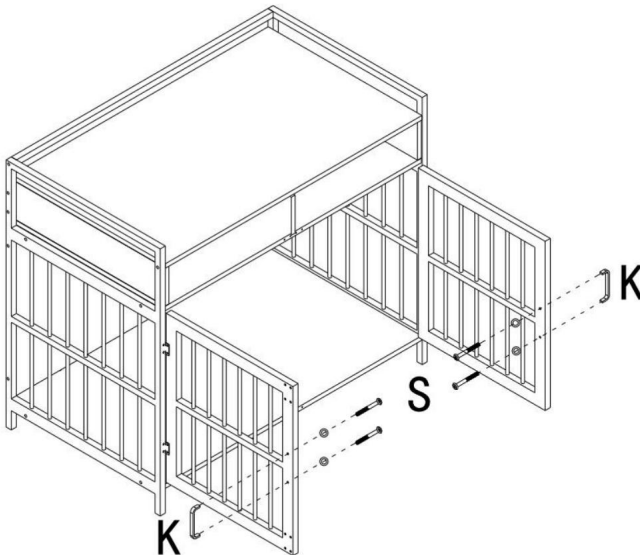

PASO 13

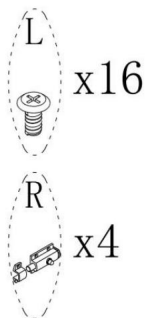
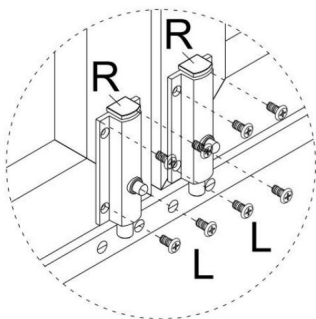
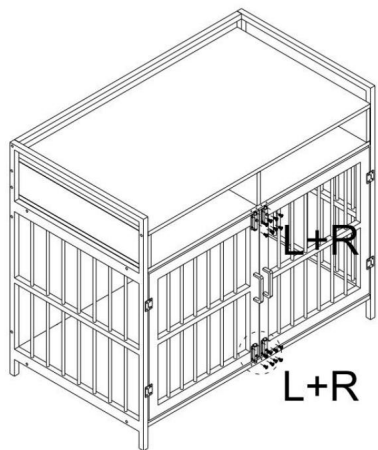

PASO 14

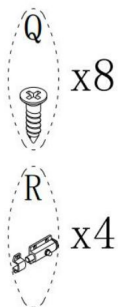
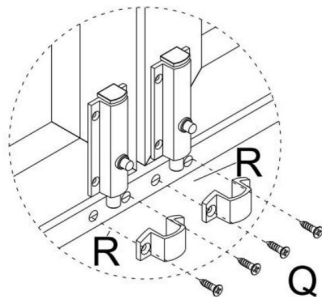
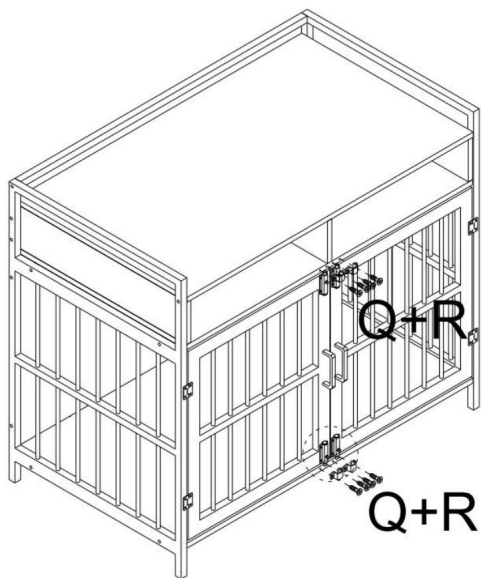

Nota: Bloquee este accesorio, el pestillo está un poco atascado, gire este accesorio para instalarlo.

Fabricante: Shanghaimuxinmuyeyouxiangongsi Dirección:  
Shuangchenglu 803nong11hao1602A-1609shi, baoshanqu, shanghai 200000 CN.

REPRESENTANTE CE: E-CrossStu GmbH.

Mainzer Landstr.69, 60329 Fráncfort del Meno.

REPRESENTANTE DEL REINO UNIDO: YH CONSULTING LIMITED.

C/O YH Consulting Limited Oficina 147, Centurion House, London Road, Staines-upon-Thames,  
Surrey, TW18 4AX Importado a AUS:

SIHAO PTY LTD.

1 ROKEVA STREET EASTWOOD NSW 2122 Australia

Importado a EE. UU.: Sanven Technology Ltd.

Suite 250, 9166 Anaheim Place, Rancho Cucamonga, CA 91730



**VEVOR**®

**TOUGH TOOLS, HALF PRICE**

Soporte técnico y certificado de garantía  
electrónica [www.vevor.com/support](http://www.vevor.com/support)



# **VEVOR<sup>®</sup>**

## **TOUGH TOOLS, HALF PRICE**

Supporto tecnico e certificato di garanzia elettronica [www.vevor.com/support](http://www.vevor.com/support)

### **MANUALE D'USO DELLA GABBIA PER CANI**

Continuiamo a impegnarci per fornirvi strumenti a prezzi competitivi.

"Risparmia la metà", "Metà prezzo" o qualsiasi altra espressione simile da noi utilizzata rappresenta solo una stima del risparmio che potresti ottenere acquistando determinati utensili con noi rispetto ai principali marchi principali e non significa necessariamente coprire tutte le categorie di utensili da noi offerti. Ti ricordiamo gentilmente di verificare attentamente quando effettui un ordine con noi se stai effettivamente risparmiando la metà rispetto ai principali marchi principali.



**VEVOR**<sup>®</sup>  
TOUGH TOOLS, HALF PRICE

TRASPORTO PER CANI

Modello: C20230602W-02

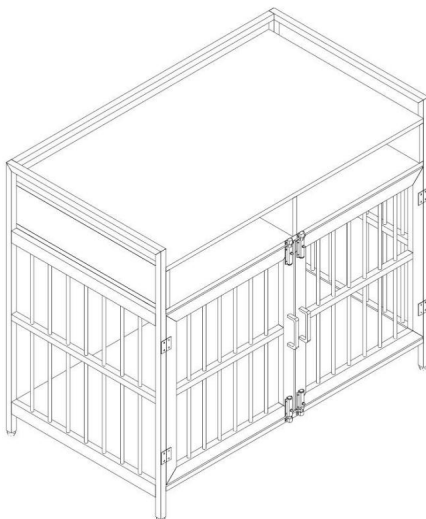

### HAI BISOGNO DI AIUTO? CONTATTACI!

Hai domande sui prodotti? Hai bisogno di supporto tecnico? Non esitare a contattarci:

**Supporto tecnico e certificato di garanzia  
elettronica [www.vevor.com/support](http://www.vevor.com/support)**

Questa è l'istruzione originale, si prega di leggere attentamente tutte le istruzioni del manuale prima di utilizzare. VEVOR si riserva una chiara interpretazione del nostro manuale utente. L'aspetto del prodotto sarà soggetto al prodotto ricevuto. Vi preghiamo di perdonarci se non vi informeremo di nuovo se ci sono aggiornamenti tecnologici o software sul nostro prodotto.

## AVVISO DI SICUREZZA

Leggere questo materiale prima di utilizzare questo prodotto. La mancata osservanza di questa norma può causare gravi infortuni.

### Precauzioni di montaggio

1. Montare solo secondo queste istruzioni. Un montaggio non corretto può creare pericoli.
2. Per garantire la tua sicurezza, assicurati di avere la sicurezza approvata dall'ANSI occhiali protettivi e guanti da lavoro resistenti durante l'installazione di questo prodotto.
3. Mantenere l'area di assemblaggio pulita e ben illuminata.
4. Tenere gli astanti fuori dall'area durante l'assemblea.
5. Non riunirsi quando si è stanchi o sotto l'effetto di alcol, droghe o farmaco.
6. Le capacità del prodotto si applicano solo ai prodotti correttamente e completamente assemblati.
7. Montare su una superficie piana, livellata, dura e liscia in grado di sostenere in modo sicuro una gabbia per cani completamente attrezzata.

### Usare precauzioni

#### PER PREVENIRE LESIONI GRAVI E MORTALI DOVUTE AL RIBALTAMENTO:

1. NON SEDERSI, STARE IN PIEDI O SALIRE SU QUESTO OGGETTO.
2. Questo prodotto non è un giocattolo. Non permettere ai bambini di giocare con o vicino a questo articolo. Si prega di tenere i pezzi di ricambio di piccole dimensioni fuori dalla portata dei bambini.
3. Utilizzare solo su una superficie piana, livellata, dura e liscia in grado di supportare in modo sicuro un gabbia per cani completamente attrezzata.
4. Utilizzare solo come previsto.
5. Ispezionare prima di ogni utilizzo; non utilizzare se alcune parti sono allentate o danneggiate.

## SALVA QUESTE ISTRUZIONI

## SPECIFICHE

Modello	C20230602W-02
Dimensioni del prodotto	41*23,6*36,2 pollici
Colore	Marrone

# COMPONENTI

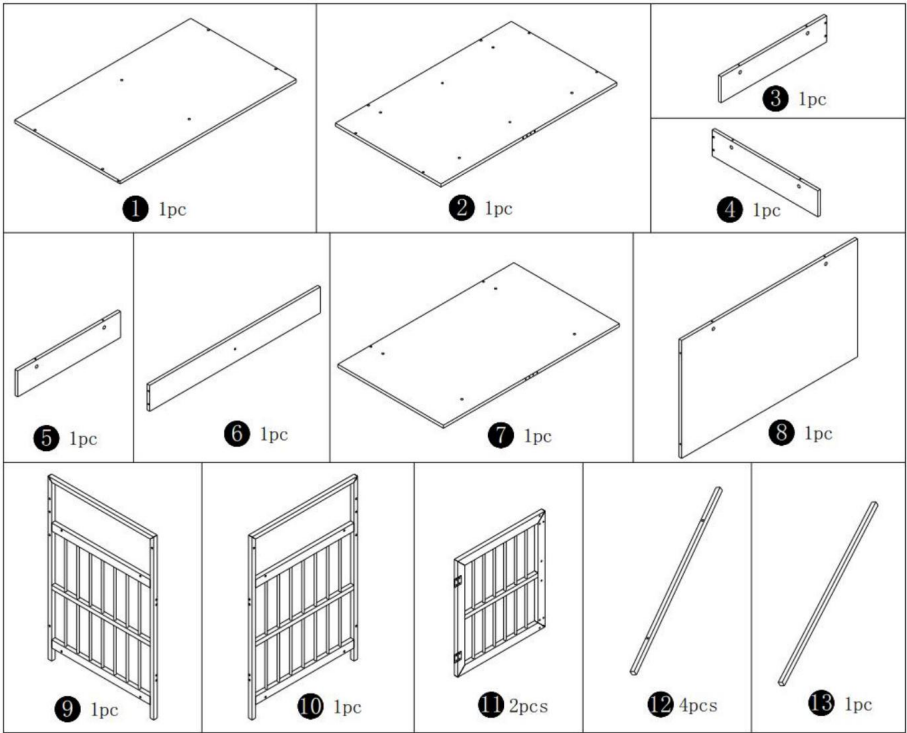

# Istruzioni di montaggio

## Installazione di camme e perni

Avvitare il perno nel foro. Per impostare correttamente le camme, assicurarsi che la freccia sulla camma si apra verso il foro del perno che sta bloccando. Bloccare la camma ruotandola stretta. Si prega di non utilizzare un cacciavite per assemblare l'unità. la testa della camma con un cacciavite finché non .

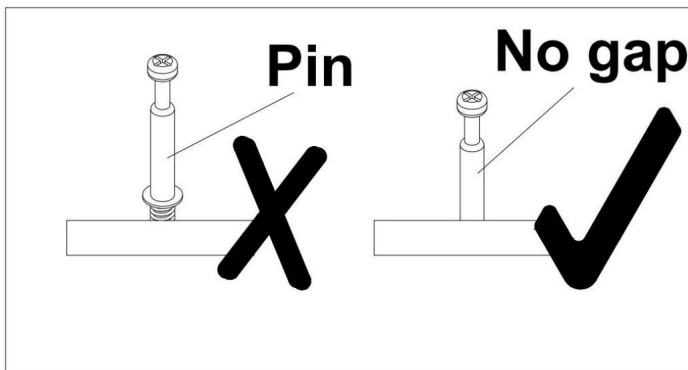
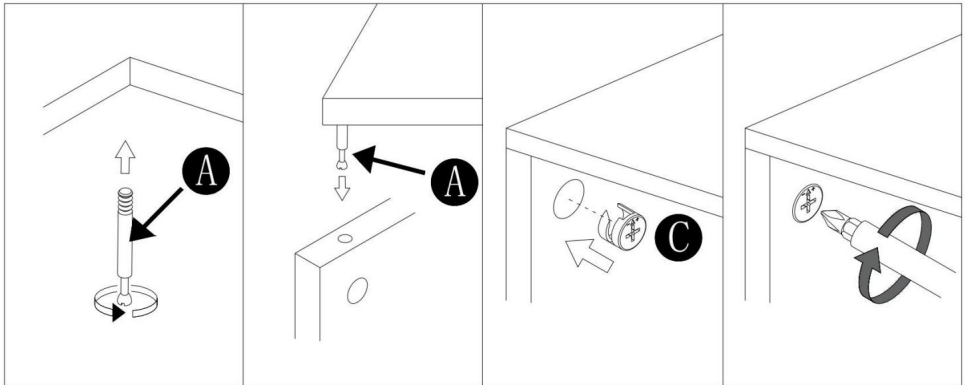

Leggi attentamente ogni passaggio prima di iniziare. È molto importante che ogni passaggio di istruzione venga eseguito in nell'ordine corretto. Se questi passaggi non vengono seguiti in sequenza, si verificheranno difficoltà di assemblaggio.

PASSO 1

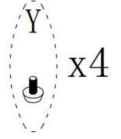
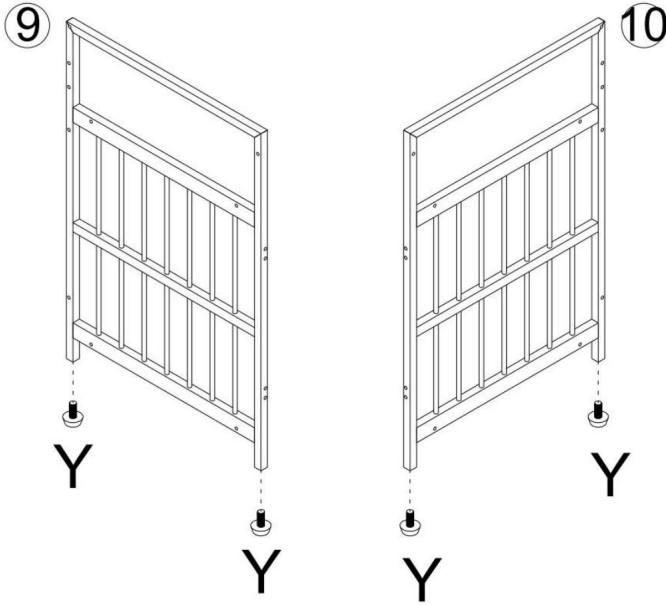

PASSO 2

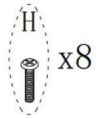
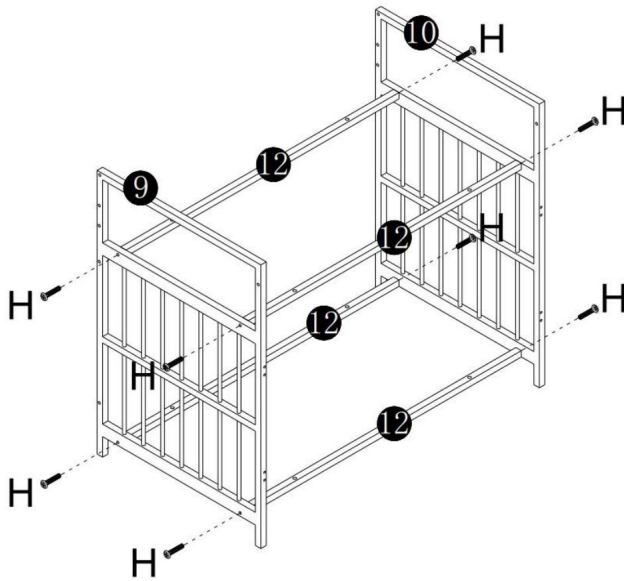

PASSO 3

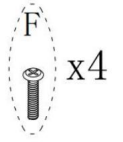
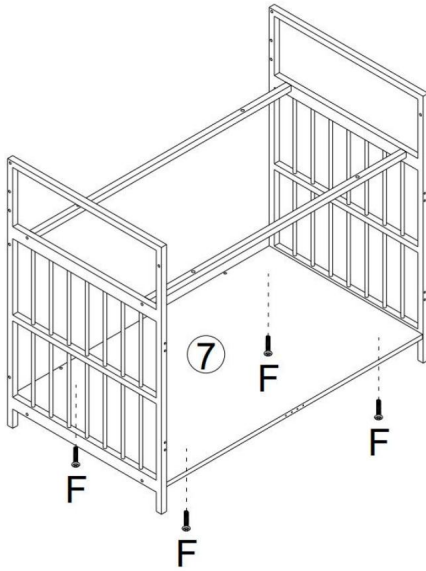

PASSO4

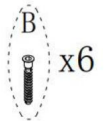
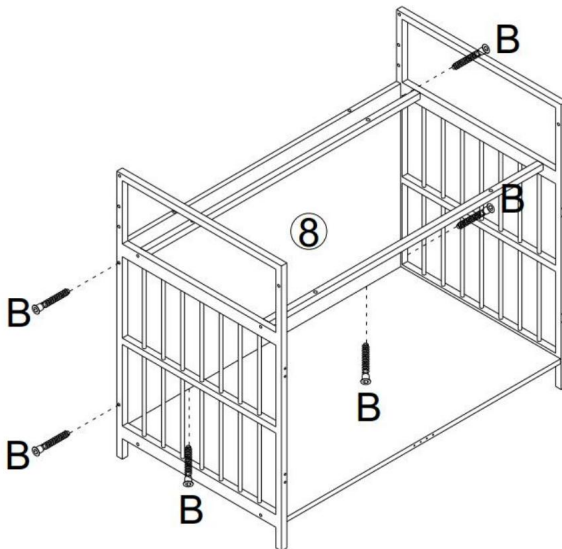



PASSO 5

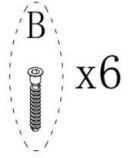
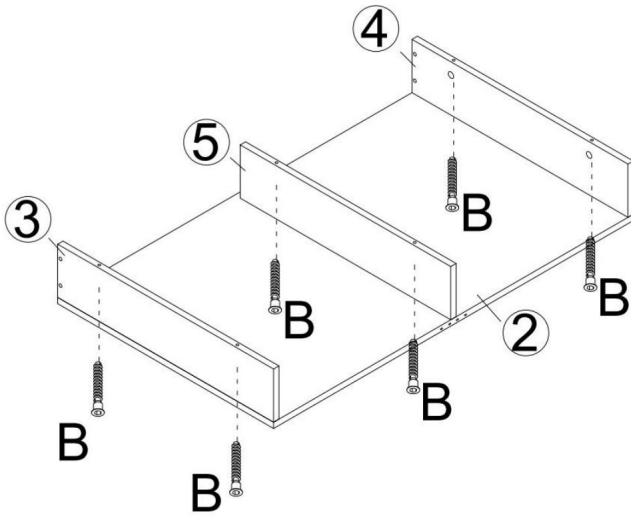

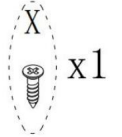
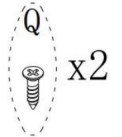
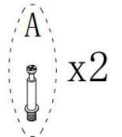
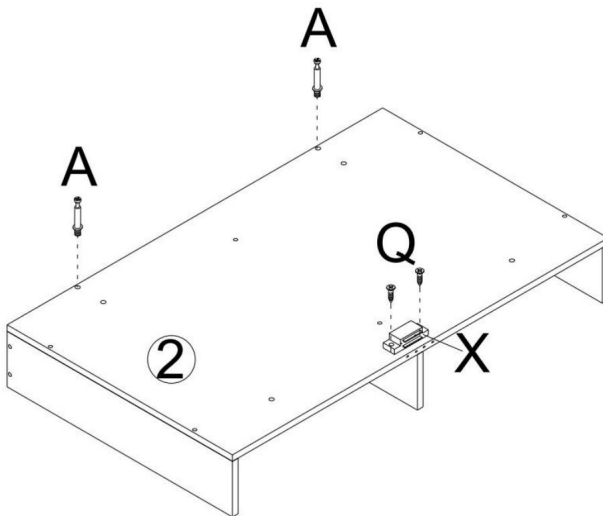

PASSO6

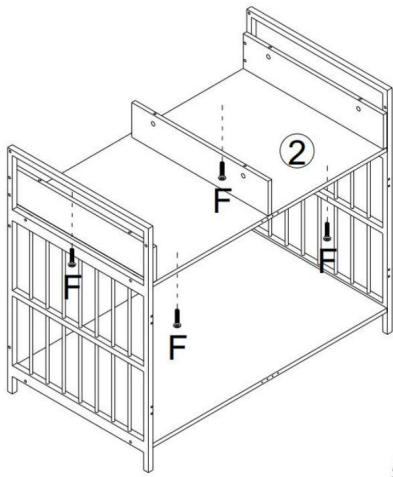

PASSO 7



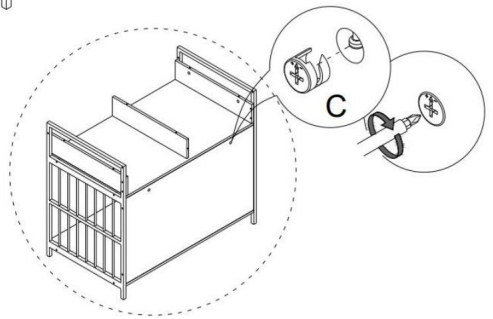

-  x2
-  x4

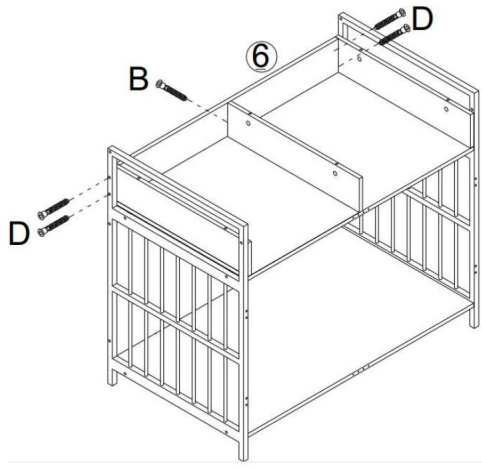

PASSO 8



-  x1
-  x4

PASSO 9

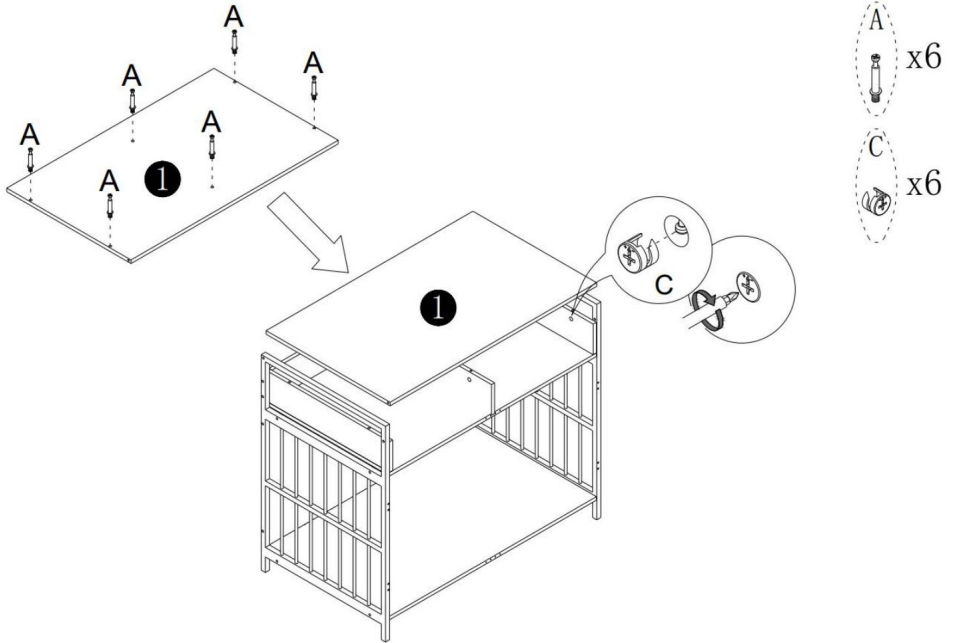

PASSO 10

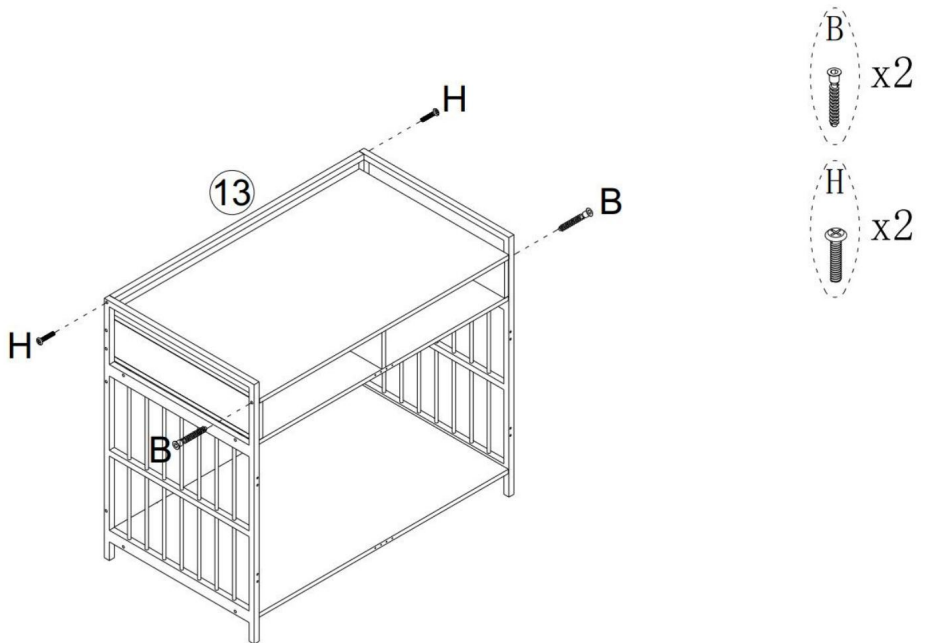

PASSO11

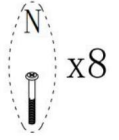
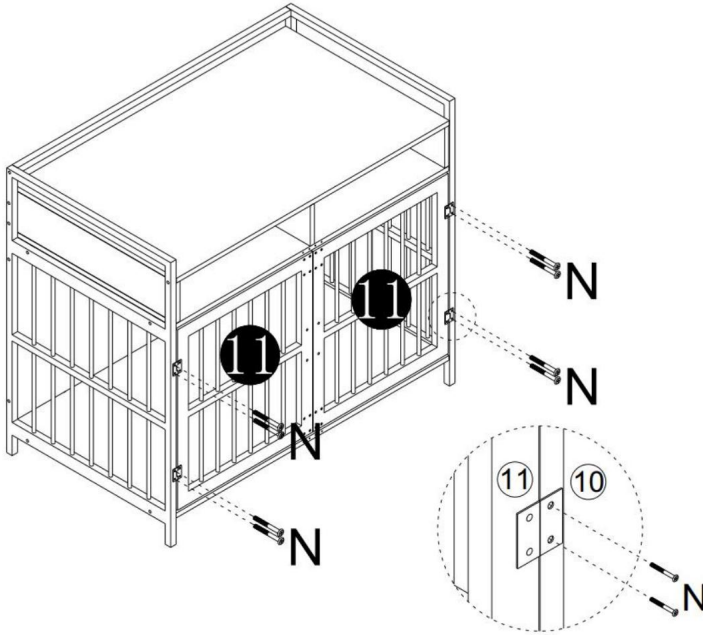

PASSO12

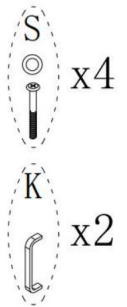
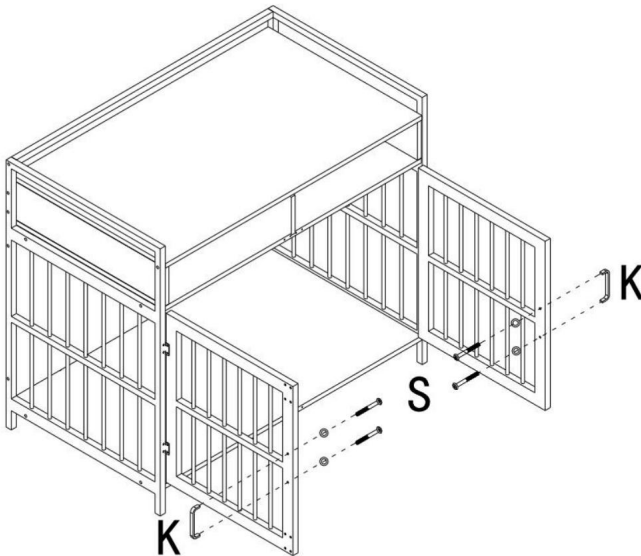

**PASSO13**

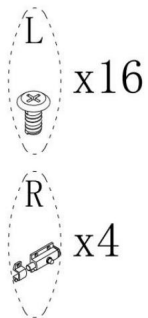
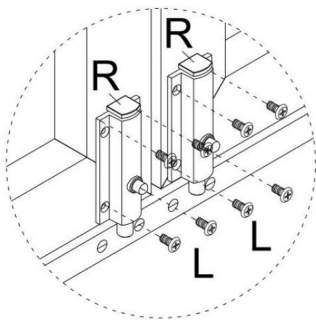
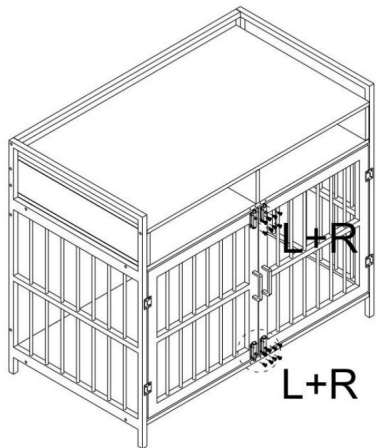

**PASSO14**

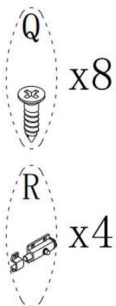
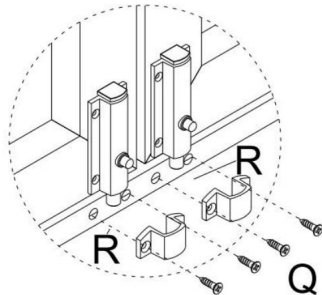
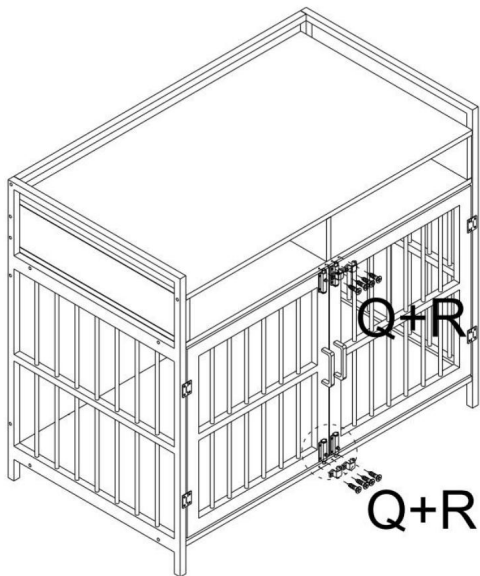

Nota: bloccare questo accessorio, il fermo è leggermente bloccato, ruotare l'accessorio per installarlo.

Produttore: Shanghaimuxinmuyeyouxiangongsi Indirizzo:  
Shuangchenglu 803nong11hao1602A-1609shi, baoshanqu, shanghai 200000 CN.

RAPPRESENTANTE CE: E-CrossStu GmbH.

Mainzer Landstr.69, 60329 Francoforte sul Meno.

RAPPRESENTANTE DEL REGNO UNITO: YH CONSULTING LIMITED.

C/O YH Consulting Limited Ufficio 147, Centurion House, London Road, Staines-upon-Thames,  
Surrey, TW18 4AX Importato in AUS:

SIHAO PTY LTD.

1 ROKEVA STREET EASTWOOD NSW 2122 Australia

Importato negli USA: Sanven Technology Ltd.

Suite 250, 9166 Anaheim Place, Rancho Cucamonga, CA 91730



**VEVOR<sup>®</sup>**

**TOUGH TOOLS, HALF PRICE**

**Supporto tecnico e certificato di garanzia  
elettronica [www.vevor.com/support](http://www.vevor.com/support)**



# VEVOR<sup>®</sup>

## TOUGH TOOLS, HALF PRICE

Wsparcie techniczne i certyfikat gwarancji elektronicznej [www.vevor.com/support](http://www.vevor.com/support)

### INSTRUKCJA OBSŁUGI KLATKI DLA PSA

Nadal staramy się oferować Państwu narzędzia w konkurencyjnych cenach. „Oszczędź połowę”, „Połowa ceny” lub inne podobne wyrażenia używane przez nas stanowią jedynie szacunkowe oszczędności, jakie możesz uzyskać, kupując u nas określone narzędzia w porównaniu z głównymi markami i niekoniecznie oznaczają one objęcie wszystkich kategorii narzędzi oferowanych przez nas. Uprzejmie przypominamy, aby dokładnie sprawdzić, czy składając u nas zamówienie faktycznie oszczędzasz połowę w porównaniu z głównymi markami.



**VEVOR**<sup>®</sup>  
TOUGH TOOLS, HALF PRICE

KLATKA DLA PSA

Model: C20230602W-02

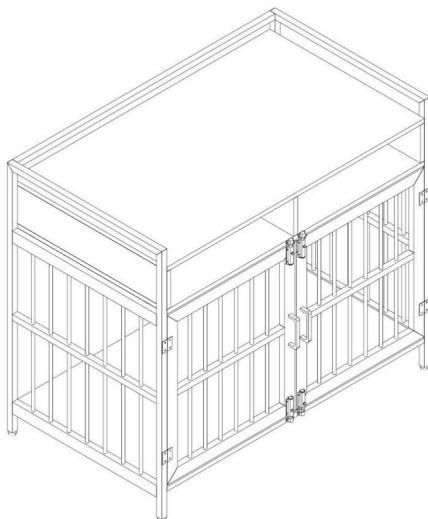

POTRZEBUJESZ POMOCY? SKONTAKTUJ SIĘ Z NAMI!

Masz pytania dotyczące produktu? Potrzebujesz wsparcia technicznego? Skontaktuj się z nami:

Wsparcie techniczne i certyfikat gwarancji  
elektronicznej [www.vevor.com/support](http://www.vevor.com/support)

To jest oryginalna instrukcja, przed użyciem należy uważnie przeczytać wszystkie instrukcje. VEVOR zastrzega sobie jasną interpretację naszej instrukcji obsługi. Wygląd produktu będzie zależał od produktu, który otrzymałeś. Prosimy o wybaczenie, że nie poinformujemy Cię ponownie, jeśli w naszym produkcie pojawią się jakiegokolwiek aktualizacje technologiczne lub oprogramowania.

## UWAGA DOTYCZĄCA BEZPIECZEŃSTWA

Przeczytaj ten materiał przed użyciem tego produktu. Nieprzestrzeganie tego może skutkować poważnymi obrażeniami.

### Środki ostrożności podczas montażu

1. Montaż należy wykonywać wyłącznie zgodnie z niniejszą instrukcją. Nieprawidłowy montaż może spowodować zagrożenia.
2. Aby zapewnić sobie bezpieczeństwo, upewnij się, że posiadasz sprzęt zgodny z normami bezpieczeństwa ANSI. Podczas montażu tego produktu należy nosić okulary ochronne i wytrzymałe rękawice robocze.
3. Utrzymuj miejsce zgromadzenia w czystości i zapewnij dobre oświetlenie.
4. Podczas montażu nie dopuszczaj osób postronnych na teren montażu.
5. Nie należy gromadzić się, gdy jest się zmęczonym lub pod wpływem alkoholu, narkotyków lub lek.
6. Możliwości produktu odnoszą się wyłącznie do produktów prawidłowo i kompletnie zmontowanych.
7. Montaż należy wykonać na płaskiej, równej, twardej i gładkiej powierzchni, która będzie w stanie bezpiecznie utrzymać ciężar. w pełni wyposażona klatka dla psa.

Stosuj środki ostrożności

### ABY ZAPOBIEC POWAŻNYM OBRAŻENIOM I ŚMIERCI SPOWODOWANEJ PRZEWRÓCENIEM:

1. NIE SIADAJ, NIE STÓJ ANI NIE WSPINAJ SIĘ NA TYM PRZEDMIOCIE.
2. Ten produkt nie jest zabawką. Nie pozwalaj dzieciom bawić się tym przedmiotem ani przebywać w jego pobliżu. Małe części zamienne należy przechowywać w miejscu niedostępnym dla dzieci.
3. Używać wyłącznie na płaskiej, równej, twardej i gładkiej powierzchni, która może bezpiecznie utrzymać w pełni załadowana klatka dla psa.
4. Używać wyłącznie zgodnie z przeznaczeniem.
5. Przed każdym użyciem należy przeprowadzić kontrolę. Nie należy używać produktu, jeśli jakieś części są luźne lub uszkodzone.

## ZAPISZ TE INSTRUKCJE

## SPECYFIKACJE

Model	C20230602W-02
Rozmiar produktu	41*23,6*36,2 cala
Kolor	Brązowy

# SKŁADNIKI

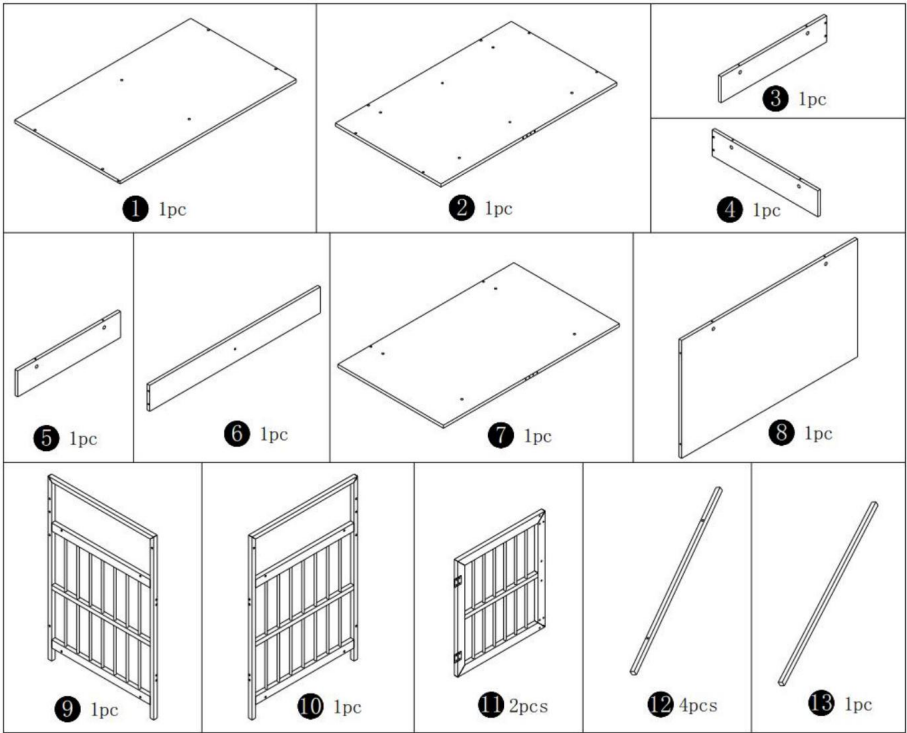

# Instrukcja montażu

## Montaż krzywek i sworzni

Wkręć sworznię w otwór. Aby prawidłowo ustawić krzywkę, upewnij się, że strzałka na krzywce otwiera się w otwór sworzni. Zablokuj krzywkę, obracając ją dokręcając. Proszę nie używać elektrycznego śrubokrętu do montażu jednostki. Głowicę krzywkową śrubokrętem, aż do jej .

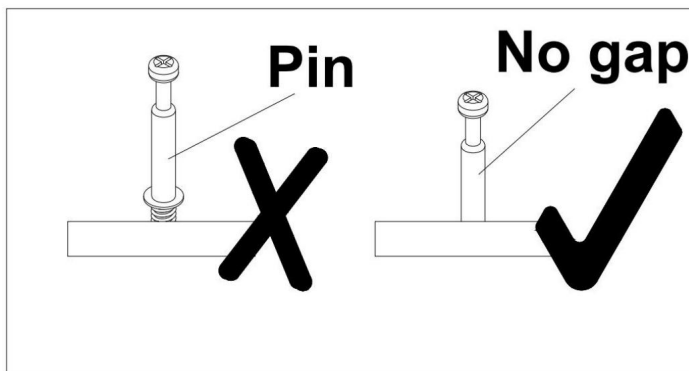
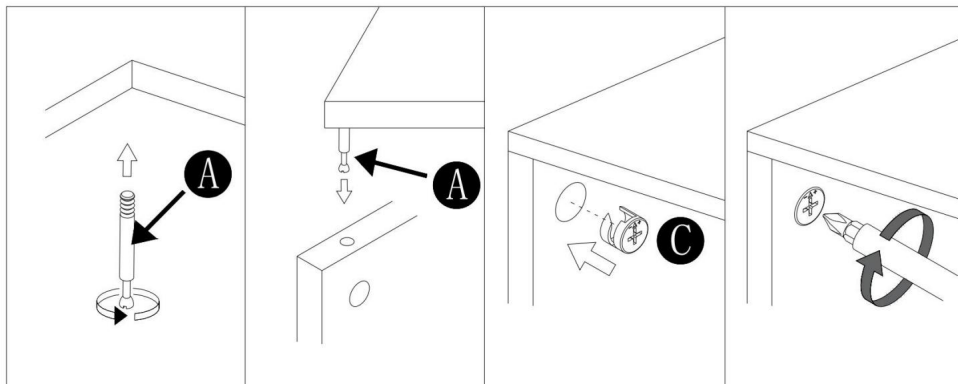

Przeczytaj uważnie każdy krok przed rozpoczęciem. Bardzo ważne jest, aby każdy krok instrukcji był wykonywany w prawidłowej kolejności. Jeśli te kroki nie zostaną wykonane w odpowiedniej kolejności, wystąpią trudności z montażem.

KROK 1

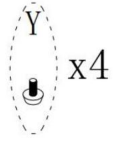
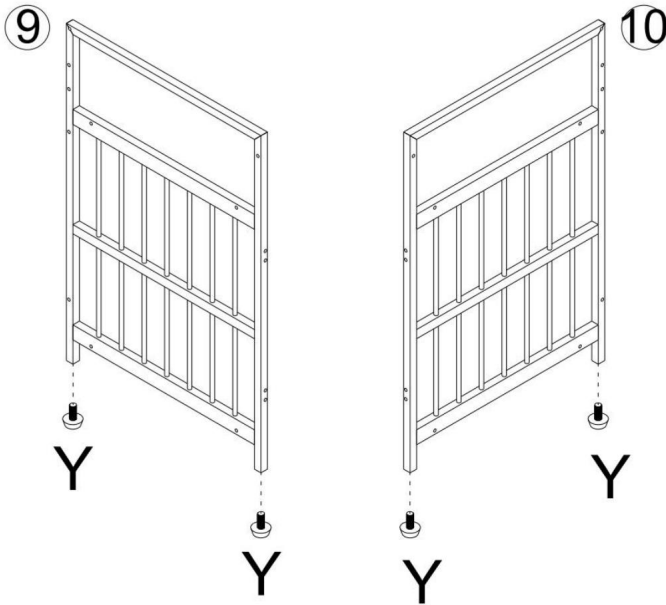

KROK 2

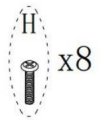
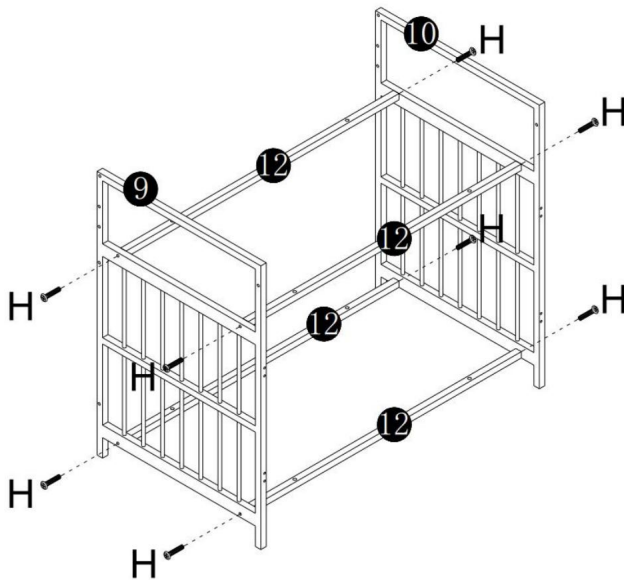

KROK 3

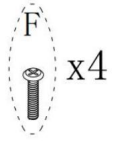
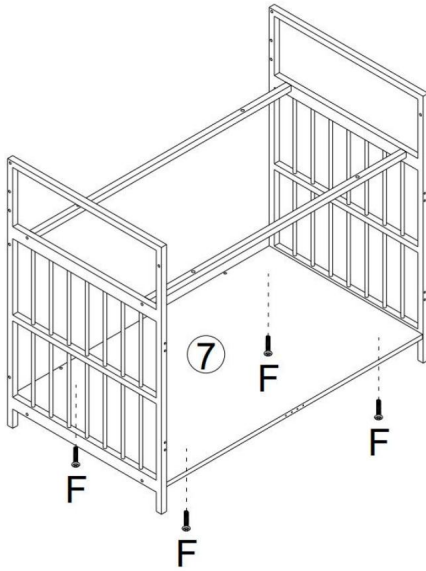

KROK 4

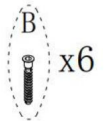
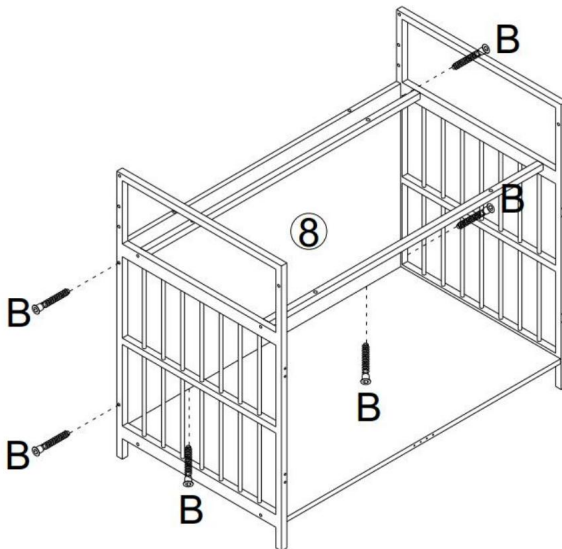



KROK 5

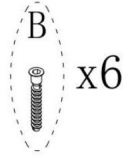
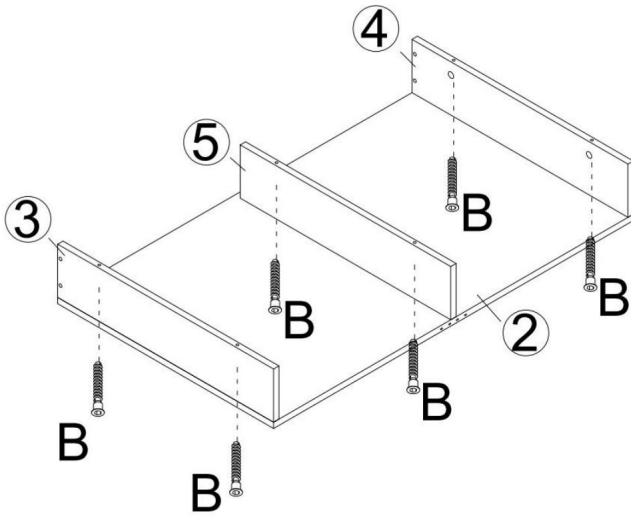

KROK 6

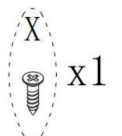
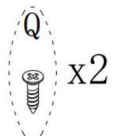
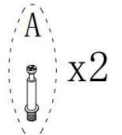
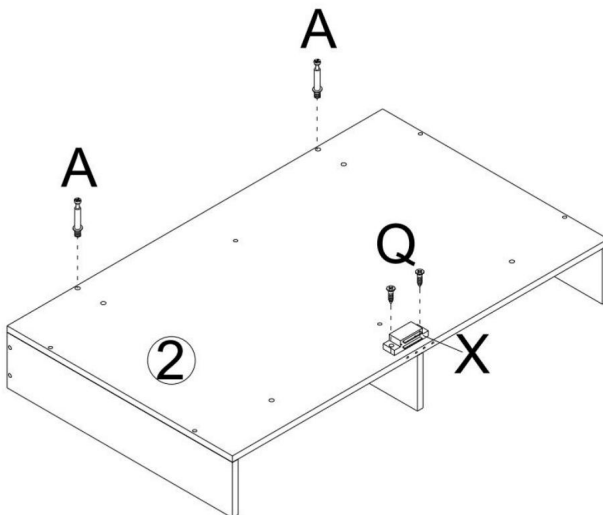

KROK 7

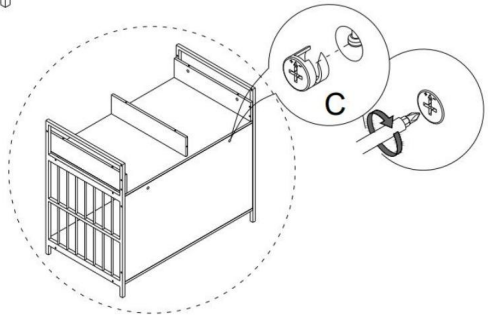
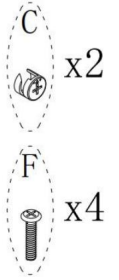
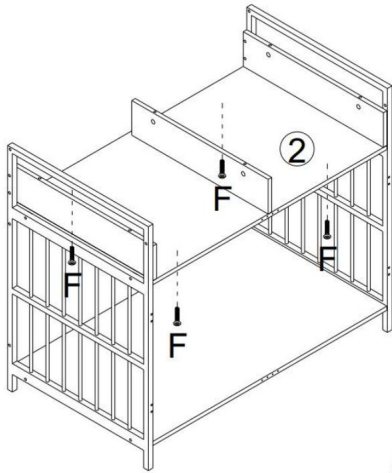

KROK 8

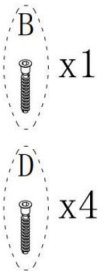
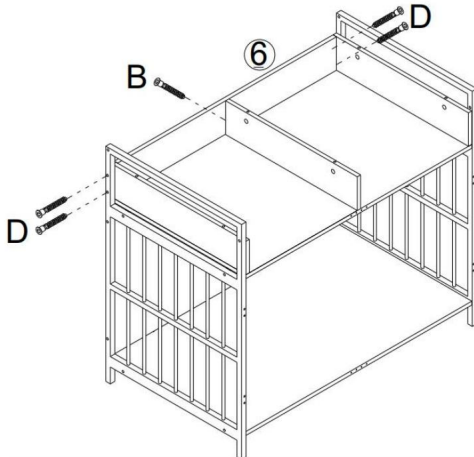

KROK 9

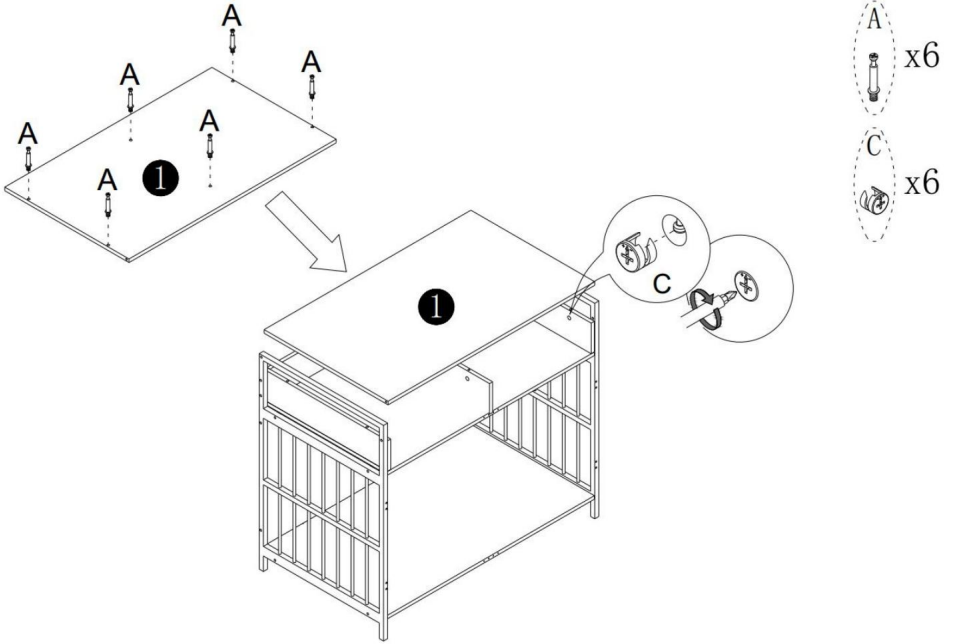

KROK 10

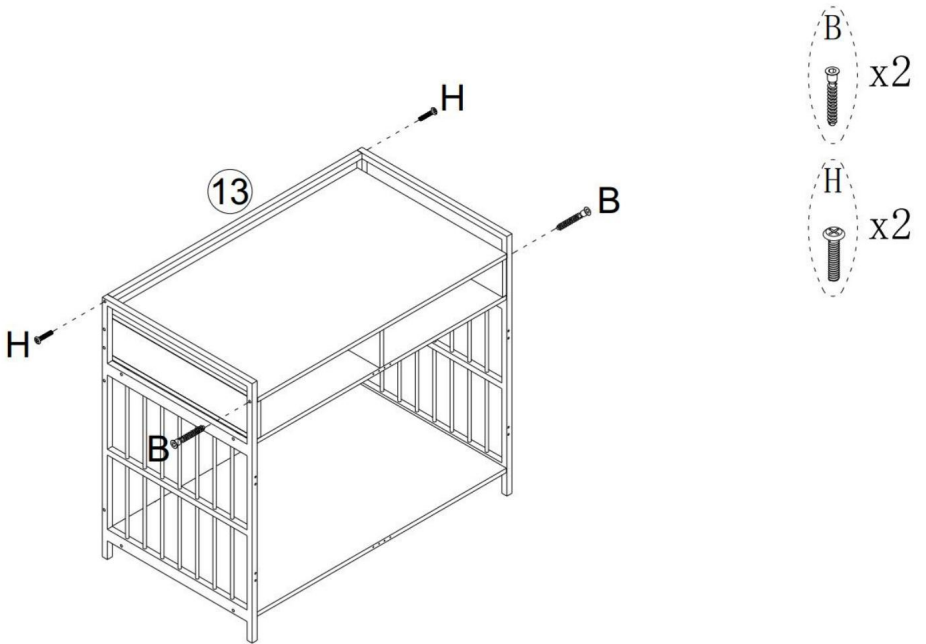

KROK 11

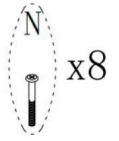
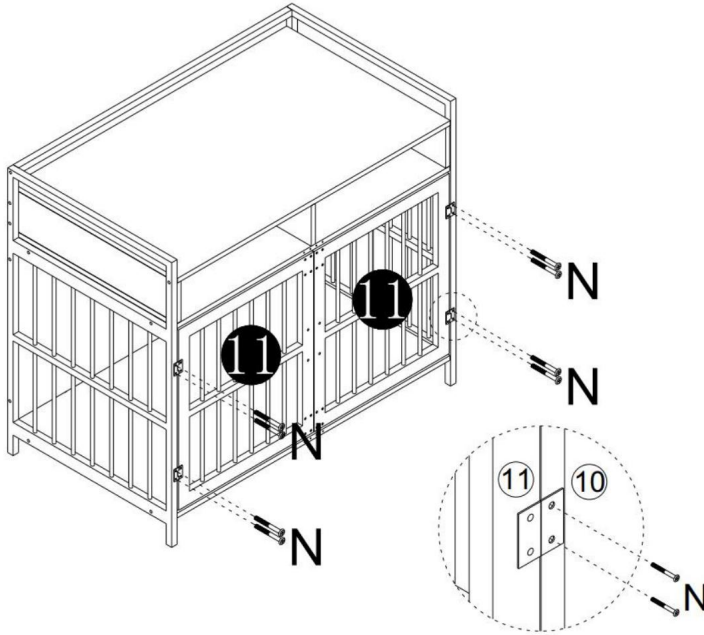

KROK 12

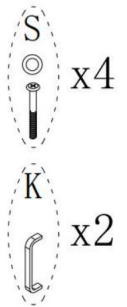
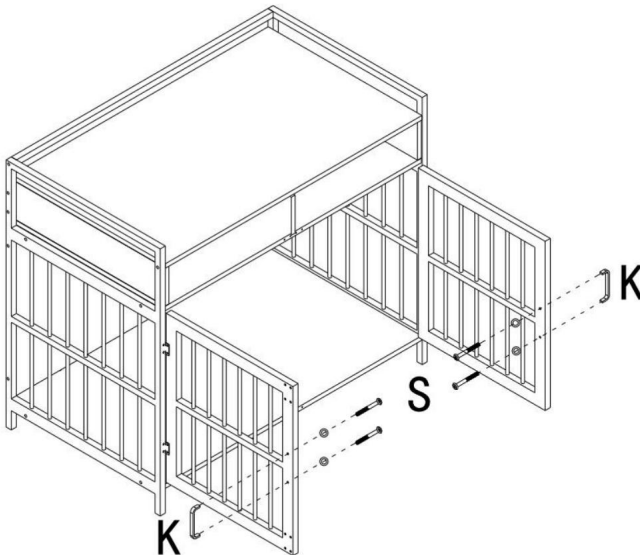

KROK 13

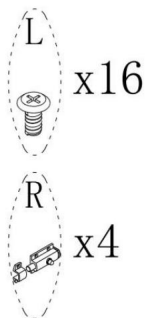
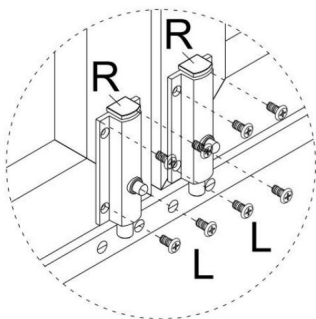
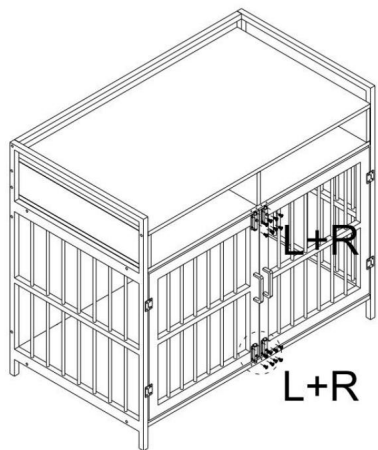

KROK 14

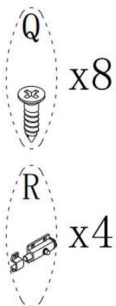
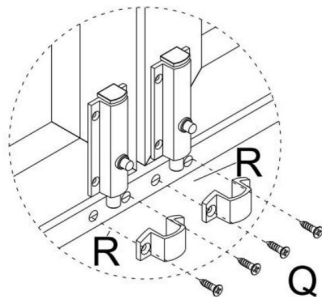
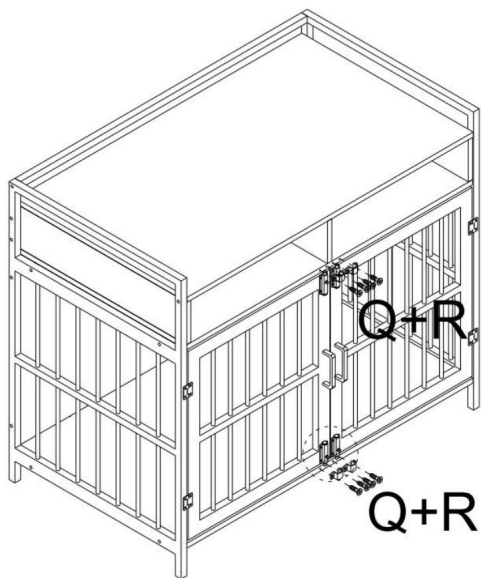

Uwaga: Zablokuj to akcesorium, zatrzask jest lekko zacięty, aby je zamontować, przekręć to akcesorium.

Producent: Shanghaimuxinmuyeyouxiangongsi Adres:  
Shuangchenglu 803nong11hao1602A-1609shi, baoshanqu, szanghaj 200000 CN.

Przedstawiciel KE: E-CrossStu GmbH.

Mainzer Landstr.69, 60329 Frankfurt nad Menem.

ODPOWIEDZIALNOŚĆ W WIELKIEJ BRYTANII: YH CONSULTING LIMITED.

C/O YH Consulting Limited Biuro 147, Centurion House, London Road, Staines-upon-Thames, Surrey,  
TW18 4AX Importowane do AUS: SIHAO

PTY LTD.

1 ROKEVA STREETEASTWOOD NSW 2122 Australia

Importowane do USA: Sanven Technology Ltd.

Apartament 250, 9166 Anaheim Place, Rancho Cucamonga, CA 91730



**VEVOR**®

**TOUGH TOOLS, HALF PRICE**

Wsparcie techniczne i certyfikat gwarancji  
elektronicznej [www.vevor.com/support](http://www.vevor.com/support)