

# **VEVOR<sup>®</sup>**

**TOUGH TOOLS, HALF PRICE**

Technical Support and E-Warranty Certificate [www.vevor.com/support](http://www.vevor.com/support)

## **BOAT TRAILER DOLLY USER MANUAL**

**MODEL:CY420**

We continue to be committed to provide you tools with competitive price.

"Save Half", "Half Price" or any other similar expressions used by us only represents an estimate of savings you might benefit from buying certain tools with us compared to the major top brands and does not necessarily mean to cover all categories of tools offered by us. You are kindly reminded to verify carefully when you are placing an order with us if you are actually saving half in comparison with the top major brands.

# VEVOR®

TOUGH TOOLS, HALF PRICE

## BOAT TRAILER DOLLY

MODEL:CY420



### NEED HELP? CONTACT US!

Have product questions? Need technical support? Please feel free to contact us:

**Technical Support and E-Warranty Certificate**  
**[www.vevor.com/support](http://www.vevor.com/support)**

This is the original instruction, please read all manual instructions carefully before operating. VEVOR reserves a clear interpretation of our user manual. The appearance of the product shall be subject to the product you received. Please forgive us that we won't inform you again if there are any technology or software updates on our product.

## SAFETY INSTRUCTIONS



**WARNING:** Read and understand all instructions. Failure to follow all instructions listed below may result in serious injury.

1. Check whether the tire has enough gas before use. If the tire gas is not enough, please inflate the tire before use.
2. Check whether the screw part is loose, if yes, please tighten it.
3. Do not overload.



**CAUTION:** Please read the instructions for safe operation carefully.

### Assembly Precautions

1. Assemble only according to these instructions. Improper assembly can create hazards.
2. Wear ANSI-approved safety goggles and heavy-duty work gloves during assembly.
3. Keep assembly area clean and well lit.
4. Keep bystanders out of the area during assembly.
5. Do not assemble when tired or when under the influence of alcohol, drugs or medication.
6. Weight capacity and other product capabilities apply to properly and completely assembled product only.
7. Assemble on a flat, level, hard and smooth surface capable of safely supporting a fully loaded boat trailer dolly.

### Use Precautions

TO PREVENT SERIOUS INJURY AND DEATH FROM TIPPING:

1. Do not sit, stand or climb on this item.
2. This product is not a toy. Do not allow children to play with or near this item.
3. Do not lift while loaded.

4. To prevent tipping, push/pull using supplied handle only.
5. Use as intended only.
6. Inspect before every use; do not use if parts are loose or damaged.
7. After use, please dry before storage to avoid rusting of bolts affecting use.

## SAVE THESE INSTRUCTIONS

### MODEL AND PARAMETERS

<b>Model</b>	<b>CY420</b>
Maximum Load	420 lbs
Product Size(Max.)	LxWxH= 310.5x107.5x48 cm
Wheel	16" Pneumatic Tire
Adjustable Length	244~294cm
Material	Steel





## STRUCTURE DIAGRAM



1.Handle 2.Supporting Plate 3.Main Rod 4.Reinforcing Rod  
5.Pneumatic Tire

## COMPONENTS

 <p style="text-align: center;">A × 1</p>	 <p style="text-align: center;">B × 2</p>	 <p style="text-align: center;">C × 3</p>
 <p style="text-align: center;">D × 1</p>	 <p style="text-align: center;">E × 1</p>	 <p style="text-align: center;">F × 2</p>
 <p style="text-align: center;">G × 2</p>	 <p style="text-align: center;">H × 2</p>	 <p style="text-align: center;">L × 1</p>
 <p style="text-align: center;">Y1 × 8 (M8*20)</p>	 <p style="text-align: center;">Y2 × 6 (M10*45)</p>	 <p style="text-align: center;">Y3 × 4 (M8*20)</p>

 <p>X1 × 12 (M8)</p>	 <p>X2 × 6 (M10)</p>	 <p>X3 × 2 (M20)</p>
 <p>Z1 × 12 (Φ8)</p>	 <p>Z2 × 6 (Φ10)</p>	

## ASSEMBLY

Tools needed



Socket Wrench

**Step 1:** Connect **G** with **X2+Y2 +Z2** and install it on **A**



**Step 2:** Connect **B** with **X3** and install it on **A**



**Step 3:** Connect **C** with **X2+Y2+Z2** and install it on **A**



**Step 4:** Connect **C** with **X2+Y2 +Z2** and install it on **D**





**Step 5:** Connect **F** with **X1+Y3+Z1** and install it on **D**



**Step 6:** Connect **E** to **D** with **L**



**Step 7:** Re-confirm that all parts are locked, and then properly inflate the tires, and the maximum of tire pressure should not exceed 24PSI, and it's ready to go.

**NOTE** that do not exceed the prescribed tire pressure to avoid bursting.

## **MAINTENANCE**

- Do not overload.
- After use, please dry before storage to avoid rusting of bolts affecting use.
- Check bolts regularly for looseness.

**Manufacturer:** Shanghaimuxinmuyeyouxiangongsi

**Address:** Shuangchenglu 803nong11hao1602A-1609shi, baoshanqu, shanghai 200000 CN.

**Imported to AUS:** SIHAO PTY LTD, 1 ROKEVA STREETEASTWOOD NSW 2122 Australia

**Imported to USA:** Sanven Technology Ltd., Suite 250, 9166 Anaheim Place, Rancho Cucamonga, CA 91730

<b>EC</b>	<b>REP</b>
-----------	------------

E-CrossStu GmbH  
Mainzer Landstr.69, 60329 Frankfurt am Main.

<b>UK</b>	<b>REP</b>
-----------	------------

YH CONSULTING LIMITED.  
C/O YH Consulting Limited Office 147, Centurion House,  
London Road, Staines-upon-Thames, Surrey, TW18 4AX



**VEVOR<sup>®</sup>**

**TOUGH TOOLS, HALF PRICE**

**Technical Support and E-Warranty Certificate**

**[www.vevor.com/support](http://www.vevor.com/support)**

# **VEVOR<sup>®</sup>**

**TOUGH TOOLS, HALF PRICE**

Technique Certificat d'assistance et de garantie électronique

[www.vevor.com/support](http://www.vevor.com/support)

## **CHARIOT POUR REMORQUE DE BATEAU MANUEL D'UTILISATION**

**MODÈLE: CY420**

We continue to be committed to provide you tools with competitive price.

"Save Half", "Half Price" or any other similar expressions used by us only represents an estimate of savings you might benefit from buying certain tools with us compared to the major top brands and does not necessarily mean to cover all categories of tools offered by us. You are kindly reminded to verify carefully when you are placing an order with us if you are actually saving half in comparison with the top major brands.



# VEVOR®

TOUGH TOOLS, HALF PRICE

## BOAT TRAILER DOLLY

MODÈLE: CY420



### NEED HELP? CONTACT US!

Have product questions? Need technical support? Please feel free to contact us:

**Technical Support and E-Warranty Certificate**  
**[www.vevor.com/support](http://www.vevor.com/support)**

This is the original instruction, please read all manual instructions carefully before operating. VEVOR reserves a clear interpretation of our user manual. The appearance of the product shall be subject to the product you received. Please forgive us that we won't inform you again if there are any technology or software updates on our product.

## SAFETY INSTRUCTIONS



**AVERTISSEMENT** : Lisez et comprenez toutes les instructions. Le non-respect de toutes les instructions ci-dessous peut entraîner des blessures graves.

1. Vérifiez si le pneu contient suffisamment de gaz avant utilisation. Si le niveau de gaz du pneu n'est pas suffisant, gonflez le pneu avant utilisation.
2. Vérifiez si la partie vissée est desserrée, si oui, serrez-la.
3. Ne pas surcharger.



**PRUDENCE**: Veuillez lire attentivement les instructions pour une utilisation en toute sécurité.

### Précautions d'assemblage

1. Assembler uniquement selon ces instructions. Un assemblage incorrect peut créer des dangers.
2. Portez des lunettes de sécurité approuvées ANSI et des gants de travail robustes pendant l'assemblage.
3. Gardez la zone de montage propre et bien éclairée.
4. Gardez les spectateurs hors de la zone pendant l'assemblage.
5. Ne montez pas lorsque vous êtes fatigué ou sous l'influence de l'alcool, de drogues ou de médicaments.
6. La capacité de poids et les autres capacités du produit s'appliquent uniquement au produit correctement et complètement assemblé.
7. Assemblez sur une surface plane, de niveau, dure et lisse capable de supporter en toute sécurité un chariot de remorque de bateau entièrement chargé.

### Précautions d'emploi

POUR ÉVITER LES BLESSURES GRAVES ET LA MORT RÉSULTANT DU BASCULEMENT :



1. Ne vous asseyez pas, ne vous levez pas et ne grimpez pas sur cet article.
2. Ce produit n'est pas un jouet. Ne laissez pas les enfants jouer avec ou à proximité de cet article.
3. Ne pas soulever pendant la charge.
4. Pour éviter tout basculement, poussez/tirez uniquement à l'aide de la poignée fournie.
5. Utiliser uniquement comme prévu.
6. Inspectez avant chaque utilisation ; ne pas utiliser si des pièces sont desserrées ou endommagées.
7. Après utilisation, veuillez sécher avant de ranger pour éviter la rouille des boulons affectant l'utilisation.

## SAUVEZ-LES INSTRUCTIONS

### MODEL AND PARAMETERS

Modèle	CY420
Charge maximale	420 livres
Taille du produit ( max .)	LxlxH= 310,5x107,5x48 cm
Roue	16 " Pneumatique
Longueur réglable	244~294cm
Matériel	Acier





## STRUCTURE DIAGRAM



1. Poignée 2. Plaque de support 3. Tige principale 4. Tige de renfort  
5. Pneumatique

## COMPONENTS

 <p style="text-align: center;"><math>U_n \times 1</math></p>	 <p style="text-align: center;"><math>B \times 2</math></p>	 <p style="text-align: center;"><math>C \times 3</math></p>
 <p style="text-align: center;"><math>D \times 1</math></p>	 <p style="text-align: center;"><math>E \times 1</math></p>	 <p style="text-align: center;"><math>F \times 2</math></p>
 <p style="text-align: center;"><math>G \times 2</math></p>	 <p style="text-align: center;"><math>H \times 2</math></p>	 <p style="text-align: center;"><math>L \times 1</math></p>
 <p style="text-align: center;"><math>Y1 \times 8</math> (M8*20)</p>	 <p style="text-align: center;"><math>Y2 \times 6</math> (M10*45)</p>	 <p style="text-align: center;"><math>Y3 \times 4</math> (M8*20)</p>

 <p>X1 × 12 (M8)</p>	 <p>X2 × 6 (M10)</p>	 <p>X3 × 2 (M20)</p>
 <p>Z1 × 12 ( Φ 8 )</p>	 <p>Z2 × 6 ( Φ 10 )</p>	

## ASSEMBLY

Outils nécessaires



Clé à douille

**Étape 1** : Connectez **G** avec **X2+Y2 +Z2** et installez-le sur **A**



**Étape 2** : Connectez **B** avec **X3** et installez-le sur **A**



**Étape 3** : Connectez **C** avec **X2+Y2 +Z2** et installez-le sur **A**



**Étape 4** : Connectez **C** avec **X2+Y2 +Z2** et installez-le sur **D**



**Étape 5** : Connectez **F** avec **X1+Y3 +Z1** et installez-le sur **D**



**Étape 6** : Connectez **E** à **D** avec **L**

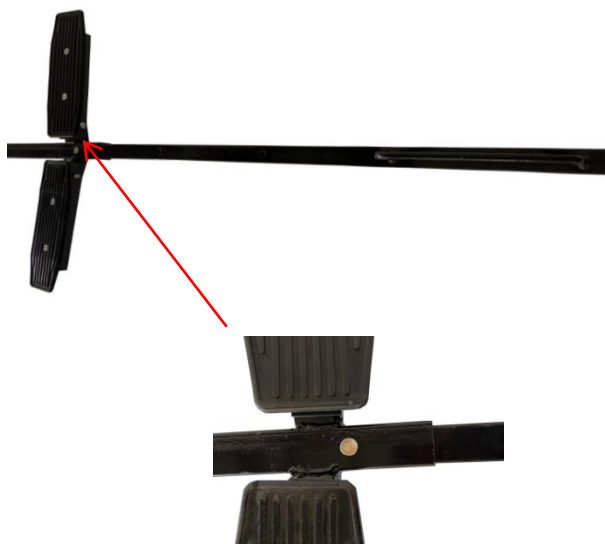

**Étape 7** : Confirmez à nouveau que toutes les pièces sont verrouillées, puis gonflez correctement les pneus, et la pression maximale des pneus ne doit pas dépasser 24 PSI, et c'est prêt à partir.

**ATTENTION** : ne pas dépasser la pression des pneus prescrite pour éviter l'éclatement.

## **ENTRETIEN**

- Ne pas surcharger.
- Après utilisation, veuillez sécher avant de ranger pour éviter la rouille des boulons affectant l'utilisation.

- Vérifiez régulièrement que les boulons ne sont pas desserrés.

**Fabricant** : Shanghaimuxinmuyeyouxiangongsi

**Adresse** : Shuangchenglu 803nong11hao1602A-1609shi, baoshanqu, shanghai 200000 CN.

**Importé en Australie** : SIHAO PTY LTD, 1 ROKEVA STREET, ASTWOOD NSW 2122 Australie

**Importé aux États-Unis** : Sanven Technology Ltd., Suite 250, 9166 Anaheim Place, Rancho Cucamonga, CA 91730

<b>EC</b>	<b>REP</b>
-----------	------------

E-CrossStu GmbH  
Mainzer Landstr.69, 60329 Frankfurt am Main.

<b>UK</b>	<b>REP</b>
-----------	------------

YH CONSULTING LIMITED.  
C/O YH Consulting Limited Office 147, Centurion House,  
London Road. Staines-upon-Thames. Surrey. TW18 4AX





**VEVOR**<sup>®</sup>

**TOUGH TOOLS, HALF PRICE**

**Technique Certificat d'assistance et de garantie électronique**

**[www.vevor.com/support](http://www.vevor.com/support)**

# **VEVOR<sup>®</sup>**

**TOUGH TOOLS, HALF PRICE**

Technisch Support und E-Garantie-Zertifikat [www.vevor.com/support](http://www.vevor.com/support)

## **BOOTSANHÄNGER DOLLY BEDIENUNGSANLEITUNG**

**MODELL: CY420**

We continue to be committed to provide you tools with competitive price.

"Save Half", "Half Price" or any other similar expressions used by us only represents an estimate of savings you might benefit from buying certain tools with us compared to the major top brands and does not necessarily mean to cover all categories of tools offered by us. You are kindly reminded to verify carefully when you are placing an order with us if you are actually saving half in comparison with the top major brands.

# VEVOR<sup>®</sup>

TOUGH TOOLS, HALF PRICE

## BOAT TRAILER DOLLY

MODELL: CY420



### NEED HELP? CONTACT US!

Have product questions? Need technical support? Please feel free to contact us:

**Technical Support and E-Warranty Certificate**  
**[www.vevor.com/support](http://www.vevor.com/support)**

This is the original instruction, please read all manual instructions carefully before operating. VEVOR reserves a clear interpretation of our user manual. The appearance of the product shall be subject to the product you received. Please forgive us that we won't inform you again if there are any technology or software updates on our product.

## SAFETY INSTRUCTIONS



**WARNUNG:** Lesen und verstehen Sie alle Anweisungen. Die Nichtbeachtung aller unten aufgeführten Anweisungen kann zu schweren Verletzungen führen.

1. Überprüfen Sie vor dem Gebrauch, ob der Reifen genügend Gas hat. Wenn nicht genug Gas vorhanden ist, pumpen Sie den Reifen vor dem Gebrauch auf.
2. Überprüfen Sie, ob die Schraube locker ist. Wenn ja, ziehen Sie sie bitte fest.
3. Nicht überladen.



**VORSICHT:** Für einen sicheren Betrieb lesen Sie bitte die Anleitung sorgfältig durch.

### **Vorsichtsmaßnahmen bei der Montage**

1. Nur gemäß dieser Anleitung zusammenbauen. Unsachgemäße Montage kann Gefahren verursachen.
2. Tragen Sie während der Montage eine ANSI-geprüfte Schutzbrille und strapazierfähige Arbeitshandschuhe.
3. Halten Sie den Versammlungsbereich sauber und gut beleuchtet.
4. Halten Sie während der Montage unbeteiligte Zuschauer vom Bereich fern.
5. Nicht zusammenbauen, wenn Sie müde sind oder unter dem Einfluss von Alkohol, Drogen oder Medikamenten stehen.
6. Gewichtskapazität und andere Produkteigenschaften gelten nur für ordnungsgemäß und vollständig montierte Produkte.
7. Auf einer flachen, ebenen, harten und glatten Oberfläche zusammenbauen, die einen voll beladenen Bootsanhänger sicher tragen kann.

## **Vorsichtsmaßnahmen bei der Verwendung**

UM SCHWERE VERLETZUNGEN UND TOD DURCH KIPPEN ZU VERMEIDEN:

1. Setzen, stellen oder klettern Sie nicht auf diesen Artikel.
2. Dieses Produkt ist kein Spielzeug. Erlauben Sie Kindern nicht, mit diesem Produkt zu spielen oder sich in seiner Nähe aufzuhalten.
3. Nicht unter Last heben.
4. Um ein Umkippen zu verhindern, drücken/ziehen Sie nur mit dem mitgelieferten Griff.
5. Nur bestimmungsgemäß verwenden.
6. Vor jedem Gebrauch prüfen; nicht verwenden, wenn Teile lose oder beschädigt sind.
7. Nach dem Gebrauch vor der Lagerung trocknen lassen, um zu vermeiden, dass die Schrauben rosten und dadurch die Nutzung beeinträchtigen.

## **SPEICHERN SIE DIESE ANWEISUNGEN**

### **MODEL AND PARAMETERS**

<b>Modell</b>	<b>CY420</b>
Maximale Belastung	420 Pfund
Produktgröße ( max . )	LxBxH= 310,5x107,5x48 cm
Rad	16 " Luftreifen
Einstellbare Länge	244~294 cm
Material	Stahl

## STRUCTURE DIAGRAM











1.Griff 2.Stützplatte 3.Hauptstange 4.Verstärkungsstange

## 5.P pneumatischer Reifen

### COMPONENTS

 <p>Ein × 1</p>	 <p>B × 2</p>	 <p>C × 3</p>
 <p>T × 1</p>	 <p>E × 1</p>	 <p>F × 2</p>
 <p>G × 2</p>	 <p>H × 2</p>	 <p>L × 1</p>

 <p>Y1 × 8 (M8*20)</p>	 <p>Y2 × 6 (M10*45)</p>	 <p>Y3 × 4 (M8*20)</p>
 <p>X1 × 12 (M8)</p>	 <p>X2 × 6 (M10)</p>	 <p>X3 × 2 (M20)</p>
 <p>Z1 × 12 (F 8)</p>	 <p>Z2 × 6 (F 10)</p>	

## ASSEMBLY

Erforderliche  
Werkzeuge



Steckschlüssel

**Schritt 1:** Verbinde **G** mit **X2+Y2 +Z2** und installiere es auf **A**





**Schritt 2:** B mit X3 verbinden und auf A installieren



**Schritt 3:** Verbinde C mit X2+Y2 +Z2 und installiere es auf A



**Schritt 4:** Verbinde C mit X2+Y2 +Z2 und installiere es auf D



**Schritt 5:** F mit X1+Y3 +Z1 verbinden und auf D installieren



**Schritt 6:** Verbinden Sie E mit D mit L

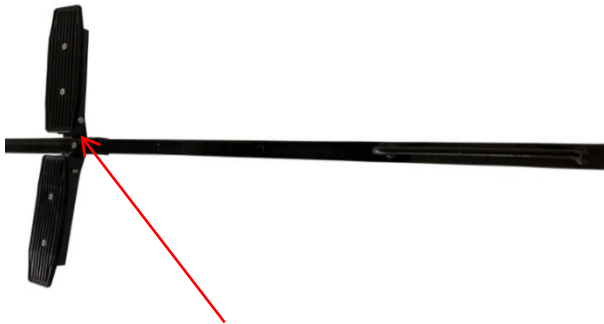



**Schritt 7:** Vergewissern Sie sich noch einmal, dass alle Teile verriegelt sind, und pumpen Sie dann die Reifen richtig auf. Der maximale Reifendruck sollte 24 PSI nicht überschreiten. Dann kann es losgehen.

**BEACHTEN SIE: Den vorgeschriebenen Reifendruck nicht überschreiten, um ein Platzen zu vermeiden.**

### **WARTUNG**

- Nicht überladen.
- Nach dem Gebrauch vor der Lagerung trocknen lassen, um ein Rosten der Schrauben zu vermeiden, das die Nutzung beeinträchtigt.
- Überprüfen Sie die Schrauben regelmäßig auf Lockerheit.

**Hersteller:** Shanghaimuxinmuyeyouxiangongsi

**Adresse:** Shuangchenglu 803nong11hao1602A-1609shi, baoshanqu, Shanghai 200000 CN.

**Nach AUS importiert:** SIHAO PTY LTD, 1 ROKEVA STREETEASTWOOD NSW 2122 Australien

**Importiert in die USA:** Sanven Technology Ltd., Suite 250, 9166 Anaheim Place, Rancho Cucamonga, CA 91730

<b>EC</b>	<b>REP</b>
-----------	------------

E-CrossStu GmbH  
Mainzer Landstr.69, 60329 Frankfurt am Main.

<b>UK</b>	<b>REP</b>
-----------	------------

YH CONSULTING LIMITED.  
C/O YH Consulting Limited Office 147, Centurion House,  
London Road. Staines-upon-Thames. Surrey. TW18 4AX





**VEVOR**<sup>®</sup>

**TOUGH TOOLS, HALF PRICE**

**Technisch Support und E-Garantie-Zertifikat**  
**[www.vevor.com/support](http://www.vevor.com/support)**

# **VEVOR<sup>®</sup>**

**TOUGH TOOLS, HALF PRICE**

Tecnico Supporto e certificato di garanzia elettronica [www.vevor.com/support](http://www.vevor.com/support)

## **CARRELLO PER RIMORCHIO BARCA MANUALE D'USO**

**MODELLO: CY420**

We continue to be committed to provide you tools with competitive price.

"Save Half", "Half Price" or any other similar expressions used by us only represents an estimate of savings you might benefit from buying certain tools with us compared to the major top brands and does not necessarily mean to cover all categories of tools offered by us. You are kindly reminded to verify carefully when you are placing an order with us if you are actually saving half in comparison with the top major brands.

# VEVOR®

TOUGH TOOLS, HALF PRICE

## BOAT TRAILER DOLLY

MODELLO: CY420



### NEED HELP? CONTACT US!

Have product questions? Need technical support? Please feel free to contact us:

**Technical Support and E-Warranty Certificate**  
**[www.vevor.com/support](http://www.vevor.com/support)**

This is the original instruction, please read all manual instructions carefully before operating. VEVOR reserves a clear interpretation of our user manual. The appearance of the product shall be subject to the product you received. Please forgive us that we won't inform you again if there are any technology or software updates on our product.



## SAFETY INSTRUCTIONS



**ATTENZIONE:** leggere e comprendere tutte le istruzioni. La mancata osservanza di tutte le istruzioni elencate di seguito può causare gravi lesioni.

1. Controllare se il pneumatico ha abbastanza gas prima dell'uso. Se il gas del pneumatico non è sufficiente, gonfiare il pneumatico prima dell'uso.
2. Controllare se la parte filettata è allentata; in caso affermativo, serrarla.
3. Non sovraccaricare.



**ATTENZIONE:** Si prega di leggere attentamente le istruzioni per un funzionamento sicuro.

### Precauzioni di montaggio

1. Assemblare solo secondo queste istruzioni. Un assemblaggio improprio può creare pericoli.
2. Durante il montaggio, indossare occhiali di sicurezza omologati ANSI e guanti da lavoro resistenti.
3. Mantenere l'area di assemblaggio pulita e ben illuminata.
4. Tenere gli astanti fuori dall'area durante l'assemblaggio.
5. Non riunirsi quando si è stanchi o sotto l'effetto di alcol, droghe o farmaci.
6. La capacità di peso e le altre caratteristiche del prodotto si applicano solo al prodotto correttamente e completamente assemblato.
7. Montare su una superficie piana, livellata, dura e liscia in grado di sostenere in modo sicuro un carrello per rimorchio per barche completamente carico.

### Precauzioni d'uso

PER PREVENIRE LESIONI GRAVI E MORTALI DOVUTE AL RIBALTAMENTO:

1. Non sedersi, salire in piedi o arrampicarsi su questo oggetto.
2. Questo prodotto non è un giocattolo. Non permettere ai bambini di giocare con o vicino a questo articolo.
3. Non sollevare oggetti carichi.
4. Per evitare il ribaltamento, spingere/tirare utilizzando solo la maniglia in dotazione.
5. Utilizzare solo come previsto.
6. Ispezionare prima di ogni utilizzo; non utilizzare se alcune parti sono allentate o danneggiate.
7. Dopo l'uso, asciugare prima di riporre per evitare che i bulloni si arrugginiscono e ne compromettano l'utilizzo.

## **SALVA QUESTI ISTRUZIONI**

### **MODEL AND PARAMETERS**

<b>Modello</b>	<b>CY420</b>
Carico massimo	420 libbre
Dimensioni del prodotto ( max .)	LxPxA= 310,5x107,5x48 cm
Ruota	16 " Pneumatico Pneumatico
Lunghezza regolabile	244~294cm
Materiale	Acciaio





## STRUCTURE DIAGRAM



1. Maniglia
2. Piastra di supporto
3. Asta principale
4. Asta di rinforzo
5. Pneumatico

## COMPONENTS

 <p style="text-align: center;">Un × 1</p>	 <p style="text-align: center;">La × 2</p>	 <p style="text-align: center;">La × 3</p>
 <p style="text-align: center;">E × 1</p>	 <p style="text-align: center;">E × 1</p>	 <p style="text-align: center;">F × 2</p>
 <p style="text-align: center;">II × 2</p>	 <p style="text-align: center;">A × 2</p>	 <p style="text-align: center;">L × 1</p>
 <p style="text-align: center;">Y1 × 8 (M8*20)</p>	 <p style="text-align: center;">Y2 × 6 (M10*45)</p>	 <p style="text-align: center;">Y3 × 4 (M8*20)</p>

 Dimensioni (M8)	 X2 × 6 (M10)	 X3 × 2 (M20)
 Z1 × 12 ( F 8 )	 Z2 × 6 ( F 10 )	

## ASSEMBLY

Strumenti necessari



Chiave a bussola

**Passaggio 1:** collega **G** con **X2+Y2 +Z2** e installalo su **A**



**Passaggio 2:** collega **B** con **X3** e installalo su **A**



**Passaggio 3:** collega **C** con **X2+Y2 +Z2** e installalo su **A**



**Passaggio 4:** collega **C** con **X2+Y2 +Z2** e installalo su **D**



**Passaggio 5:** collega **F** con **X1+Y3 +Z1** e installalo su **D**



**Passaggio 6:** collega **E** a **D** con **L**

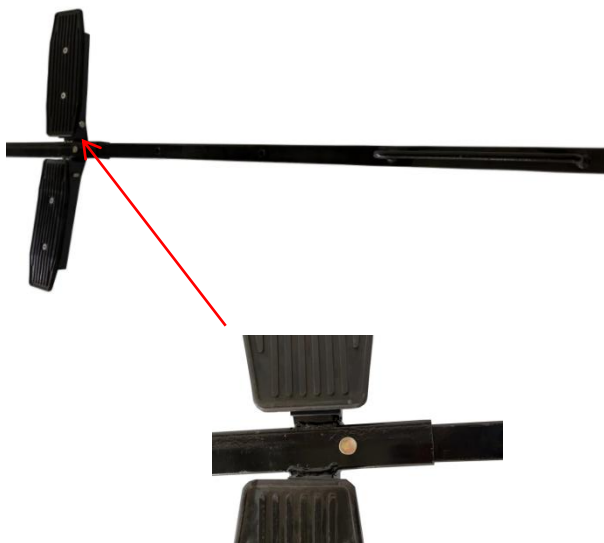

**Fase 7:** Ricontrollare che tutte le parti siano bloccate, quindi gonfiare correttamente gli pneumatici. La pressione massima degli stessi non deve superare i 24 PSI. A questo punto il mezzo è pronto per partire.

**NOTA BENE:** non superare la pressione prescritta per gli pneumatici per evitare scoppi.

## **MANUTENZIONE**

- Non sovraccaricare.
- Dopo l'uso, asciugare prima di riporre per evitare che i bulloni si arrugginiscono e ne compromettano l'utilizzo.

- Controllare regolarmente che i bulloni non siano allentati.

**Produttore:** Shanghaimuxinmuyeyouxiangongsi

**Indirizzo:** Shuangchenglu 803nong11hao1602A-1609shi, baoshanqu, shanghai 200000 CN.

**Importato in AUS:** SIHAO PTY LTD, 1 ROKEVA STREETEASTWOOD NSW 2122 Australia

**Importato negli USA:** Sanven Technology Ltd., Suite 250, 9166 Anaheim Place, Rancho Cucamonga, CA 91730

<b>EC</b>	<b>REP</b>
-----------	------------

E-CrossStu GmbH  
Mainzer Landstr.69, 60329 Frankfurt am Main.

<b>UK</b>	<b>REP</b>
-----------	------------

YH CONSULTING LIMITED.  
C/O YH Consulting Limited Office 147, Centurion House,  
London Road. Staines-upon-Thames. Surrey. TW18 4AX





**VEVOR<sup>®</sup>**

**TOUGH TOOLS, HALF PRICE**

**Tecnico Supporto e certificato di garanzia elettronica**

**[www.vevor.com/support](http://www.vevor.com/support)**

# **VEVOR<sup>®</sup>**

**TOUGH TOOLS, HALF PRICE**

Técnico Soporte y certificado de garantía electrónica [www.vevor.com/support](http://www.vevor.com/support)

## **REMOLQUE PARA BARCO DOLLY MANUAL DE USUARIO**

**MODELO: CY420**

We continue to be committed to provide you tools with competitive price.

"Save Half", "Half Price" or any other similar expressions used by us only represents an estimate of savings you might benefit from buying certain tools with us compared to the major top brands and does not necessarily mean to cover all categories of tools offered by us. You are kindly reminded to verify carefully when you are placing an order with us if you are actually saving half in comparison with the top major brands.

# VEVOR®

TOUGH TOOLS, HALF PRICE

## BOAT TRAILER DOLLY

MODELO: CY420



### NEED HELP? CONTACT US!

Have product questions? Need technical support? Please feel free to contact us:

**Technical Support and E-Warranty Certificate**  
**[www.vevor.com/support](http://www.vevor.com/support)**

This is the original instruction, please read all manual instructions carefully before operating. VEVOR reserves a clear interpretation of our user manual. The appearance of the product shall be subject to the product you received. Please forgive us that we won't inform you again if there are any technology or software updates on our product.

## SAFETY INSTRUCTIONS



**ADVERTENCIA:** Lea y comprenda todas las instrucciones. Si no sigue todas las instrucciones que se indican a continuación, puede sufrir lesiones graves.

1. Compruebe si el neumático tiene suficiente gas antes de usarlo. Si el gas del neumático no es suficiente, infle el neumático antes de usarlo.
2. Verifique si la parte del tornillo está floja, si es así, apriétela.
3. No sobrecargue.



**PRECAUCIÓN:** Lea atentamente las instrucciones para un uso seguro.

### **Precauciones de montaje**

1. Realice el montaje únicamente de acuerdo con estas instrucciones. Un montaje inadecuado puede generar peligros.
2. Use gafas de seguridad aprobadas por ANSI y guantes de trabajo resistentes durante el montaje.
3. Mantenga el área de reunión limpia y bien iluminada.
4. Mantenga a los transeúntes fuera del área durante el montaje.
5. No realizar el montaje cuando se encuentre cansado o bajo la influencia de alcohol, drogas o medicamentos.
6. La capacidad de peso y otras capacidades del producto se aplican únicamente a productos ensamblados de forma correcta y completa.
7. Móntelo sobre una superficie plana, nivelada, dura y lisa capaz de soportar de manera segura un remolque para embarcación completamente cargado.

### **Precauciones de uso**

**PARA EVITAR LESIONES GRAVES Y LA MUERTE POR VUELCO:**

1. No se siente, se pare ni se suba sobre este artículo.

2. Este producto no es un juguete. No permita que los niños jueguen con este artículo ni cerca de él.
3. No levante mientras esté cargado.
4. Para evitar que se vuelque, empuje o tire utilizando únicamente el mango suministrado.
5. Utilícelo únicamente según lo previsto.
6. Inspeccione antes de cada uso; no utilice si las piezas están sueltas o dañadas.
7. Después del uso, séquelo antes de guardarlo para evitar que la oxidación de los pernos afecte el uso.

## **GUARDE ESTOS INSTRUCCIONES**

### **MODEL AND PARAMETERS**

<b>Modelo</b>	<b>CY420</b>
Carga máxima	420 libras
Tamaño del producto ( máx .)	Largo x Ancho x Alto = 310,5 x 107,5 x 48 cm
Rueda	16 " Neumático
Longitud ajustable	244 ~ 294 cm
Material	Acero

## STRUCTURE DIAGRAM







1. Mango 2. Placa de soporte 3. Varilla principal 4. Varilla de refuerzo  
5. Neumático

## COMPONENTS

 <p style="text-align: center;">Un × 1</p>	 <p style="text-align: center;">B × 2</p>	 <p style="text-align: center;">C × 3</p>
 <p style="text-align: center;">D × 1</p>	 <p style="text-align: center;">mi × 1</p>	 <p style="text-align: center;">F × 2</p>
 <p style="text-align: center;">G × 2</p>	 <p style="text-align: center;">Alto × 2</p>	 <p style="text-align: center;">L × 1</p>
 <p style="text-align: center;">Y1 × 8 (M8*20)</p>	 <p style="text-align: center;">Y2 × 6 (M10*45)</p>	 <p style="text-align: center;">Y3 × 4 (M8*20)</p>



 <p>X1 × 12 (M8)</p>	 <p>X2×6 (M10)</p>	 <p>X3 × 2 (M20)</p>
 <p>Z1 × 12 ( F 8)</p>	 <p>Z2×6 ( F 10)</p>	

## ASSEMBLY

Herramientas  
necesarias



Llave de tubo

**Paso 1:** Conecte **G** con **X2+Y2 +Z2** e instálolo en **A**



**Paso 2:** Conecta **B** con **X3** e instálalo en **A**



**Paso 3:** Conecte **C** con **X2+Y2 +Z2** e instálelo en **A**



**Paso 4:** Conecte **C** con **X2+Y2 +Z2** e instálelo en **D**



**Paso 5:** Conecte **F** con **X1+Y3 +Z1** e instálelo en **D**



**Paso 6:** Conecta **E** a **D** con **L**

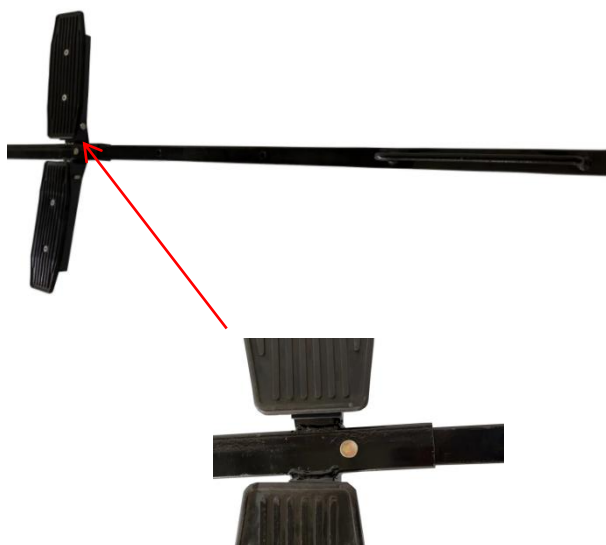

**Paso 7:** Vuelva a confirmar que todas las piezas estén bloqueadas y luego infle adecuadamente los neumáticos. La presión máxima de los neumáticos no debe exceder las 24 PSI y estará listo para funcionar.

**NOTA:** no exceda la presión de los neumáticos prescrita para evitar que revienten.

## **MANTENIMIENTO**

- No sobrecargue.
- Después de su uso, séquelo antes de guardarlo para evitar que la

oxidación de los pernos afecte su uso.

- Revise periódicamente los pernos para ver si están flojos.

**Fabricante:** Shanghaimuxinmuyeyouxiangongsi

**Dirección:** Shuangchenglu 803nong11hao1602A-1609shi, baoshanqu, shanghai 200000 CN.

**Importado a AUS:** SIHAO PTY LTD, 1 ROKEVA STREETEASTWOOD NSW 2122 Australia

**Importado a EE. UU.:** Sanven Technology Ltd., Suite 250, 9166 Anaheim Place, Rancho Cucamonga, CA 91730

<b>EC</b>	<b>REP</b>
-----------	------------

E-CrossStu GmbH  
Mainzer Landstr.69, 60329 Frankfurt am Main.

<b>UK</b>	<b>REP</b>
-----------	------------

YH CONSULTING LIMITED.  
C/O YH Consulting Limited Office 147, Centurion House,  
London Road, Staines-upon-Thames, Surrey, TW18 4AX



**VEVOR**<sup>®</sup>

**TOUGH TOOLS, HALF PRICE**

**Técnico Certificado de soporte y garantía electrónica**

**[www.vevor.com/support](http://www.vevor.com/support)**

# **VEVOR<sup>®</sup>**

**TOUGH TOOLS, HALF PRICE**

Techniczny Wsparcie i certyfikat gwarancji elektronicznej [www.vevor.com/support](http://www.vevor.com/support)

## **WÓZEK DO PRZYCZEPY ŁODZIOWEJ INSTRUKCJA OBSŁUGI**

**MODEL: CY420**

We continue to be committed to provide you tools with competitive price.

"Save Half", "Half Price" or any other similar expressions used by us only represents an estimate of savings you might benefit from buying certain tools with us compared to the major top brands and does not necessarily mean to cover all categories of tools offered by us. You are kindly reminded to verify carefully when you are placing an order with us if you are actually saving half in comparison with the top major brands.

# VEVOR<sup>®</sup>

TOUGH TOOLS, HALF PRICE

## BOAT TRAILER DOLLY

MODEL: CY420



### NEED HELP? CONTACT US!

Have product questions? Need technical support? Please feel free to contact us:

**Technical Support and E-Warranty Certificate**  
**[www.vevor.com/support](http://www.vevor.com/support)**

This is the original instruction, please read all manual instructions carefully before operating. VEVOR reserves a clear interpretation of our user manual. The appearance of the product shall be subject to the product you received. Please forgive us that we won't inform you again if there are any technology or software updates on our product.



## SAFETY INSTRUCTIONS



**OSTRZEŻENIE:** Przeczytaj i zrozum wszystkie instrukcje. Nieprzestrzeganie wszystkich instrukcji wymienionych poniżej może skutkować poważnymi obrażeniami.

1. Sprawdź, czy opona ma wystarczająco dużo gazu przed użyciem. Jeśli gazu w oponie jest za mało, napompuj oponę przed użyciem.
2. Sprawdź, czy śruba nie jest poluzowana. Jeśli tak, dokręć ją.
3. Nie przeciążaj.



**OSTROŻNOŚĆ:** Przeczytaj uważnie instrukcję, aby zapewnić bezpieczną obsługę.

### **Środki ostrożności podczas montażu**

1. Montaż należy wykonywać wyłącznie zgodnie z niniejszą instrukcją. Nieprawidłowy montaż może stwarzać zagrożenia.
2. Podczas montażu należy nosić okulary ochronne z atestem ANSI oraz wytrzymałe rękawice robocze.
3. Utrzymuj miejsce zgromadzenia w czystości i zapewnij dobre oświetlenie.
4. Nie dopuść, aby osoby postronne przebywały w pobliżu podczas montażu.
5. Nie przychodź na spotkania, jeśli jesteś zmęczony lub pod wpływem alkoholu, narkotyków lub leków.
6. Podane parametry dotyczące nośności i innych parametrów produktu odnoszą się wyłącznie do produktu prawidłowo i kompletnie zmontowanego.
7. Montaż należy wykonać na płaskiej, równej, twardej i gładkiej powierzchni, która będzie w stanie bezpiecznie utrzymać w pełni załadowany wózek do przyczepy łodzi.

## **Stosuj środki ostrożności**

**ABY ZAPOBIEC POWAŻNYM OBRAŻENIOM I ŚMIERCI SPOWODOWANEJ PRZEWRÓCENIEM:**

1. Nie siadaj, nie stawaj i nie wspinaj się na ten przedmiot.
2. Ten produkt nie jest zabawką. Nie pozwalaj dzieciom bawić się tym przedmiotem ani przebywać w jego pobliżu.
3. Nie podnoś, gdy jesteś obciążony.
4. Aby zapobiec przewróceniu, należy pchać/ciągnąć wyłącznie za dołączony uchwyt.
5. Używać wyłącznie zgodnie z przeznaczeniem.
6. Przed każdym użyciem należy przeprowadzić kontrolę. Nie należy używać produktu, jeśli jakieś części są luźne lub uszkodzone.
7. Po użyciu należy wysuszyć przed schowaniem, aby zapobiec korozji śrub, co może mieć wpływ na użytkowanie.

## **ZAPISZ TO INSTRUKCJE**

### **MODEL AND PARAMETERS**

<b>Model</b>	<b>CY420</b>
Maksymalne obciążenie	420 funtów
Rozmiar produktu ( maks . )	Dł. x szer. x wys. = 310,5 x 107,5 x 48 cm
Koło	16 " Opona pneumatyczna
Regulowana długość	244~294cm
Tworzywo	Stal









## STRUCTURE DIAGRAM



1. Uchwyt 2. Płyta podporowa 3. Pręt główny 4. Pręt wzmacniający
5. Opona pneumatyczna

## COMPONENTS

 <p style="text-align: center;">×1</p>	 <p style="text-align: center;">B ×2</p>	 <p style="text-align: center;">C ×3</p>
 <p style="text-align: center;">D ×1</p>	 <p style="text-align: center;">E ×1</p>	 <p style="text-align: center;">P2</p>
 <p style="text-align: center;">G ×2</p>	 <p style="text-align: center;">Wysokość ×2</p>	 <p style="text-align: center;">L ×1</p>

 <p>Y1 × 8 (M8*20)</p>	 <p>Y2 × 6 (M10*45)</p>	 <p>Y3 × 4 (M8*20)</p>
 <p>X1 × 12 (M8)</p>	 <p>X2 × 6 (M10)</p>	 <p>X3 × 2 (M20)</p>
 <p>Z1 × 12 ( F 8)</p>	 <p>Z2 × 6 ( F 10)</p>	

## ASSEMBLY

Potrzebne narzędzia



Klucz nasadowy

**Krok 1:** Połącz **G** z **X2+Y2 +Z2** i zainstaluj na **A**



**Krok 2:** Podłącz **B** do **X3** i zainstaluj go na **A**



**Krok 3:** Połącz **C** z **X2+Y2 +Z2** i zainstaluj na **A**



**Krok 4:** Połącz **C** z **X2+Y2 +Z2** i zainstaluj na **D**



**Krok 5:** Połącz F z X1+Y3 +Z1 i zainstaluj na D



**Krok 6:** Połącz E z D za pomocą L

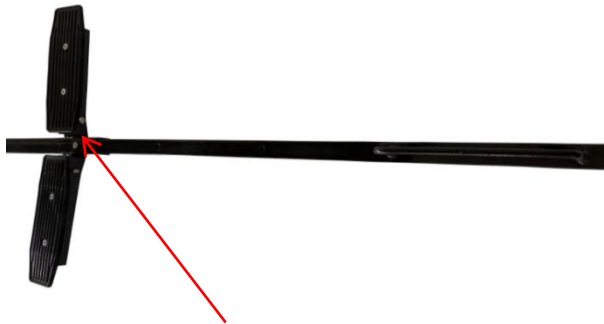



**Krok 7:** Sprawdź ponownie, czy wszystkie części są zablokowane, a następnie odpowiednio napompuj opony (maksymalne ciśnienie w oponach nie powinno przekraczać 24 PSI). Teraz możesz już jechać.

**UWAGA:** Nie przekraczaj zalecanego ciśnienia w oponach, aby uniknąć ich pęknięcia.

### KONSERWACJA

- Nie przeciążaj.
- Po użyciu należy wysuszyć przed schowaniem, aby zapobiec korozji śrub, co może mieć wpływ na użytkowanie.
- Regularnie sprawdzaj luzy śrub.

**Producent:** Shanghaimuxinmuyeyouxiangongsi

**Adres:** Shuangchenglu 803nong11hao1602A-1609shi, baoshanqu, szanghaj 200000 CN.

**Importowane do AUS:** SIHAO PTY LTD, 1 ROKEVA STREETEASTWOOD NSW 2122 Australia

**Importowane do USA:** Sanven Technology Ltd., Suite 250, 9166 Anaheim Place, Rancho Cucamonga, CA 91730

EC	REP
----	-----

E-CrossStu GmbH  
Mainzer Landstr.69, 60329 Frankfurt am Main.

UK	REP
----	-----

YH CONSULTING LIMITED.  
C/O YH Consulting Limited Office 147, Centurion House,  
London Road. Staines-upon-Thames. Surrey. TW18 4AX







**VEVOR**<sup>®</sup>

**TOUGH TOOLS, HALF PRICE**

**Techniczny Wsparcie i certyfikat e-gwarancji**

**[www.vevor.com/support](http://www.vevor.com/support)**

# **VEVOR<sup>®</sup>**

**TOUGH TOOLS, HALF PRICE**

Technisch Ondersteuning en E-garantiecertificaat [www.vevor.com/support](http://www.vevor.com/support)

## **BOOTAANHANGWAGEN DOLLY GEBRUIKSAANWIJZING**

**MODEL: CY420**

We continue to be committed to provide you tools with competitive price.

"Save Half", "Half Price" or any other similar expressions used by us only represents an estimate of savings you might benefit from buying certain tools with us compared to the major top brands and does not necessarily mean to cover all categories of tools offered by us. You are kindly reminded to verify carefully when you are placing an order with us if you are actually saving half in comparison with the top major brands.

# VEVOR®

TOUGH TOOLS, HALF PRICE

## BOAT TRAILER DOLLY

MODEL: CY420



### NEED HELP? CONTACT US!

Have product questions? Need technical support? Please feel free to contact us:

**Technical Support and E-Warranty Certificate**  
**[www.vevor.com/support](http://www.vevor.com/support)**

This is the original instruction, please read all manual instructions carefully before operating. VEVOR reserves a clear interpretation of our user manual. The appearance of the product shall be subject to the product you received. Please forgive us that we won't inform you again if there are any technology or software updates on our product.

## SAFETY INSTRUCTIONS



**WAARSCHUWING:** Lees en begrijp alle instructies. Het niet opvolgen van alle onderstaande instructies kan leiden tot ernstig letsel.

1. Controleer of de band voldoende gas heeft voor gebruik. Als de bandengas niet voldoende is, pomp de band dan op voor gebruik.
2. Controleer of het schroefgedeelte los zit. Als dat het geval is, draai het dan vast.
3. Niet overbelasten.



**VOORZICHTIGHEID:** Lees de instructies zorgvuldig door voor een veilige bediening.

### **Voorzorgsmaatregelen bij de montage**

1. Monteer alleen volgens deze instructies. Onjuiste montage kan gevaaren opleveren.
2. Draag tijdens de montage een ANSI-goedgekeurde veiligheidsbril en stevige werkhandschoenen.
3. Zorg ervoor dat de montageplek schoon en goed verlicht is.
4. Houd omstanders uit de buurt tijdens de montage.
5. Ga niet in de winkel staan als u moe bent of onder invloed van alcohol, drugs of medicijnen.
6. Het draagvermogen en andere producteigenschappen gelden alleen voor een correct en volledig gemonteerd product.
7. Monteer de set op een vlak, egaal, hard en glad oppervlak dat een volledig beladen boottrailerkar veilig kan dragen.

### **Gebruik voorzorgsmaatregelen**

OM ERNSTIG LETSEL EN DE DOOD DOOR KANTELEN TE VOORKOMEN:

1. Ga niet op dit voorwerp zitten, staan of klimmen.

2. Dit product is geen speelgoed. Laat kinderen niet met of in de buurt van dit item spelen.
3. Til niet terwijl het geladen is.
4. Om kantelen te voorkomen, duwt of trekt u alleen met behulp van de meegeleverde handgreep.
5. Gebruik het product alleen zoals bedoeld.
6. Controleer het apparaat voor elk gebruik. Gebruik het niet als er onderdelen loszitten of beschadigd zijn.
7. Laat het product na gebruik drogen voordat u het opbergt, om te voorkomen dat de bouten gaan roesten en daardoor het gebruik beïnvloeden.

## **BEWAAR DEZE INSTRUCTIES**

### **MODEL AND PARAMETERS**

<b>Model</b>	<b>CY420</b>
Maximale belasting	420 pond
Productgrootte ( max . )	LxBxH = 310,5x107,5x48 cm
Wiel	16 " Luchtband
Verstelbare lengte	244~294cm
Materiaal	Staal

## STRUCTURE DIAGRAM





1. Handvat 2. Ondersteunende plaat 3. Hoofdstang 4. Verstevigingsstang  
5. Luchtband



## COMPONENTS

 <p>Een × 1</p>	 <p>B × 2</p>	 <p>C × 3</p>
 <p>D × 1</p>	 <p>E × 1</p>	 <p>F × 2</p>
 <p>G × 2</p>	 <p>Hoogte × 2</p>	 <p>L × 1</p>
 <p>Y1 × 8 (M8*20)</p>	 <p>Jaar 2 × 6 (M10*45)</p>	 <p>Jaar 3 × 4 (M8*20)</p>

 <p>X1 × 12 (M8)</p>	 <p>2x6 cm (M10)</p>	 <p>3x2 (M20)</p>
 <p>Z1 × 12 ( F 8)</p>	 <p>Z2 × 6 ( Φ 10)</p>	

**ASSEMBLY**

<p>Benodigde gereedschappen</p>

<p>Dopsleutel</p>

**Stap 1:** Verbind **G** met **X2+Y2 +Z2** en installeer het op **A**



**Stap 2:** Verbind **B** met **X3** en installeer het op **A**



**Stap 3:** Verbind **C** met **X2+Y2 +Z2** en installeer het op **A**



**Stap 4:** Verbind **C** met **X2+Y2 +Z2** en installeer het op **D**



**Stap 5:** Verbind **F** met **X1+Y3 +Z1** en installeer het op **D**



**Stap 6:** Verbind **E** met **D** met **L**

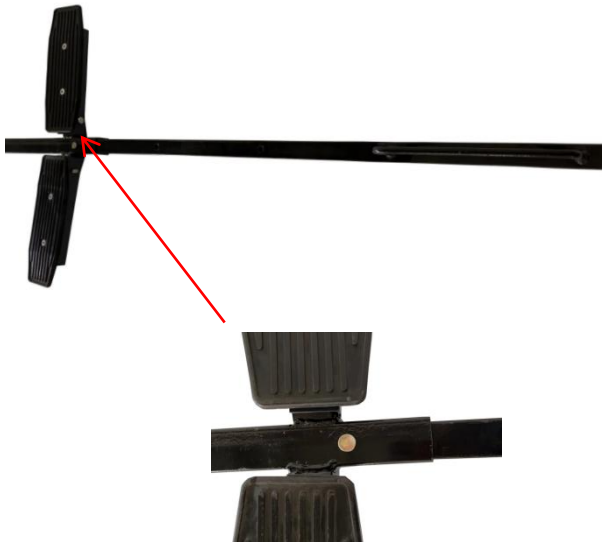

**Stap 7:** Controleer nogmaals of alle onderdelen vastzitten en pomp de banden goed op. De maximale bandenspanning mag niet hoger zijn dan 24 PSI. Dan bent u klaar voor vertrek.

**LET OP:** overschrijd de voorgeschreven bandenspanning niet om een klapband te voorkomen.

## **ONDERHOUD**

- Niet overbelasten.
- Na gebruik laten drogen voordat u het opbergt, om te voorkomen dat de

bouten gaan roesten en daardoor het gebruik beïnvloeden.

- Controleer regelmatig of de bouten loszitten.

**Fabrikant:** Shanghaimuxinmuyeyouxiangongsi

**Adres:** Shuangchenglu 803nong11hao1602A-1609shi, baoshanqu, shanghai 200000 CN.

**Geïmporteerd naar AUS:** SIHAO PTY LTD, 1 ROKEVA STREETEASTWOOD NSW 2122 Australië

**Geïmporteerd naar de VS:** Sanven Technology Ltd., Suite 250, 9166 Anaheim Place, Rancho Cucamonga, CA 91730

<b>EC</b>	<b>REP</b>
-----------	------------

E-CrossStu GmbH  
Mainzer Landstr.69, 60329 Frankfurt am Main.

<b>UK</b>	<b>REP</b>
-----------	------------

YH CONSULTING LIMITED.  
C/O YH Consulting Limited Office 147, Centurion House,  
London Road, Staines-upon-Thames, Surrey, TW18 4AX



**VEVOR**<sup>®</sup>

**TOUGH TOOLS, HALF PRICE**

**Technisch Ondersteuning en E-garantiecertificaat**

**[www.vevor.com/support](http://www.vevor.com/support)**

# **VEVOR<sup>®</sup>**

**TOUGH TOOLS, HALF PRICE**

Teknisk Support och e-garanticertifikat [www.vevor.com/support](http://www.vevor.com/support)

## **BÅTTRAILER DOLLY ANVÄNDARMANUAL**

**MODELL: CY420**

We continue to be committed to provide you tools with competitive price.

"Save Half", "Half Price" or any other similar expressions used by us only represents an estimate of savings you might benefit from buying certain tools with us compared to the major top brands and does not necessarily mean to cover all categories of tools offered by us. You are kindly reminded to verify carefully when you are placing an order with us if you are actually saving half in comparison with the top major brands.



# VEVOR®

TOUGH TOOLS, HALF PRICE

## BOAT TRAILER DOLLY

MODELL: CY420



### NEED HELP? CONTACT US!

Have product questions? Need technical support? Please feel free to contact us:

**Technical Support and E-Warranty Certificate**  
**[www.vevor.com/support](http://www.vevor.com/support)**

This is the original instruction, please read all manual instructions carefully before operating. VEVOR reserves a clear interpretation of our user manual. The appearance of the product shall be subject to the product you received. Please forgive us that we won't inform you again if there are any technology or software updates on our product.

## SAFETY INSTRUCTIONS



**VARNING:** Läs och förstå alla instruktioner. Underlåtenhet att följa alla instruktioner som anges nedan kan resultera i allvarliga skador.

1. Kontrollera om däckets tryck är tillräckligt med gas före användning. Om däckgasen inte räcker, vänligen pumpa upp däckets tryck före användning.
2. Kontrollera om skruvdelarna är lösa, om ja, dra åt dem.
3. Överbelasta inte.



**FÖRSIKTIGHET:** Läs instruktionerna för säker användning noggrant.

### Försiktighetsåtgärder vid montering

1. Montera endast enligt dessa instruktioner. Felaktig montering kan skapa faror.
2. Bär ANSI-godkända skyddsglasögon och kraftiga arbetshandskar vid montering.
3. Håll monteringsområdet rent och väl upplyst.
4. Håll åskådare borta från området under monteringen.
5. Sätt dig inte ihop när du är trött eller påverkad av alkohol, droger eller medicin.
6. Viktkapacitet och andra produkttegenskaper gäller endast för korrekt och färdigmonterad produkt.
7. Montera på en plan, jämn, hård och slät yta som säkert kan stödja en fullastad båttrailer.

### Använd försiktighetsåtgärder

FÖR ATT FÖRHINDRA ALLVARLIGA SKADA OCH DÖDSFALL VID VÄLLNING:

1. Sitt, stå eller klättra inte på detta föremål.
2. Denna produkt är inte en leksak. Låt inte barn leka med eller nära detta föremål.

3. Lyft inte när den är lastad.
4. För att förhindra tippning, tryck/dra endast med det medföljande handtaget.
5. Använd endast på avsett sätt.
6. Inspektera före varje användning; Använd inte om delar är lösa eller skadade.
7. Efter användning, vänligen torka före förvaring för att undvika att bultar rostas som påverkar användningen.

## SPARA DESSA INSTRUKTIONER

### MODEL AND PARAMETERS

Modell	CY420
Maximal belastning	420 lbs
Produktstorlek ( max . )	LxBxH= 310,5x107,5x48 cm
Hjul	16 " P pneumatiskt däck
Justerbar längd	244~294 cm
Material	Stål





## STRUCTURE DIAGRAM



- 1. Handtag
- 2. Stödplatta
- 3. Huvudstång
- 4. Förstärkningsstång
- 5. P pneumatiskt däck

## COMPONENTS

 <p style="text-align: center;">A × 1</p>	 <p style="text-align: center;">B × 2</p>	 <p style="text-align: center;">C × 3</p>
 <p style="text-align: center;">D × 1</p>	 <p style="text-align: center;">E × 1</p>	 <p style="text-align: center;">F × 2</p>
 <p style="text-align: center;">G × 2</p>	 <p style="text-align: center;">H × 2</p>	 <p style="text-align: center;">L × 1</p>
 <p style="text-align: center;">Y1 × 8 (M8*20)</p>	 <p style="text-align: center;">Y2 × 6 (M10*45)</p>	 <p style="text-align: center;">Y3 × 4 (M8*20)</p>

 <p>X1 × 12 (M8)</p>	 <p>X2 × 6 (M10)</p>	 <p>X3 × 2 (M20)</p>
 <p>Z1 × 12 (Φ 8)</p>	 <p>Z2 × 6 (Φ 10)</p>	

## ASSEMBLY

Verkttyg som behövs



Hylsnyckel

**Steg 1:** Anslut **G** med **X2+Y2 +Z2** och installera den på **A**



**Steg 2:** Anslut **B** med **X3** och installera den på **A**



**Steg 3:** Anslut **C** med **X2+Y2 +Z2** och installera den på **A**



**Steg 4:** Anslut **C** med **X2+Y2 +Z2** och installera den på **D**



**Steg 5:** Anslut F med X1+Y3 +Z1 och installera den på D



**Steg 6:** Anslut E till D med L

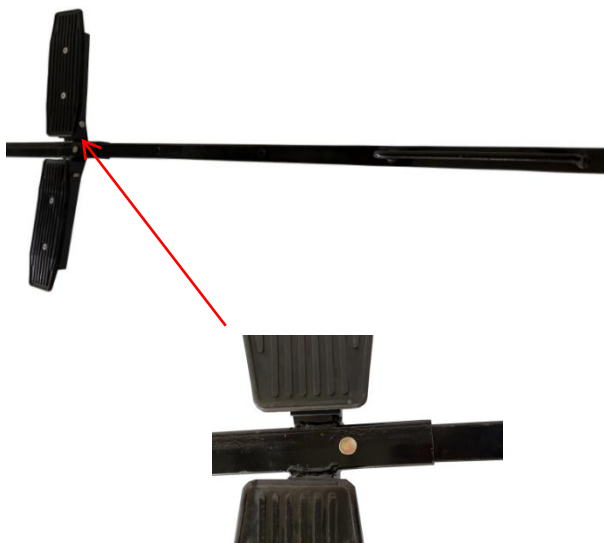

**Steg 7:** Bekräfta igen att alla delar är låsta och pumpa sedan upp däcken ordentligt, och det maximala däcktrycket bör inte överstiga 24PSI, och det är klart att köra.

**OBS att inte överskrida det föreskrivna däcktrycket för att undvika att de spricker.**

## **UNDERHÅLL**

- Överbelasta inte.
- Efter användning, vänligen torka före förvaring för att undvika att bultar rostar som påverkar användningen.



- Kontrollera regelbundet att bultarna är lösa.

**Tillverkare:** Shanghaimuxinmuyeyouxiangongsi

**Adress:** Shuangchenglu 803nong11hao1602A-1609shi, baoshanqu, shanghai 200000 CN.

**Importerad till AUS:** SIHAO PTY LTD, 1 ROKEVA STREETEASTWOOD NSW 2122 Australien

**Importerad till USA:** Sanven Technology Ltd., Suite 250, 9166 Anaheim Place, Rancho Cucamonga, CA 91730

<b>EC</b>	<b>REP</b>
-----------	------------

E-CrossStu GmbH  
Mainzer Landstr.69, 60329 Frankfurt am Main.

<b>UK</b>	<b>REP</b>
-----------	------------

YH CONSULTING LIMITED.  
C/O YH Consulting Limited Office 147, Centurion House,  
London Road. Staines-upon-Thames. Surrey. TW18 4AX



**VEVOR<sup>®</sup>**

**TOUGH TOOLS, HALF PRICE**

**Teknisk Support och e-garanticertifikat**

**[www.vevor.com/support](http://www.vevor.com/support)**