

VEVOR[®]

TOUGH TOOLS, HALF PRICE

Technical Support and E-Warranty Certificate www.vevor.com/support

INSTRUCTION FOR PATIO GAZEBOS

MODEL:KD-TY007-1

We continue to be committed to provide you tools with competitive price.

"Save Half", "Half Price" or any other similar expressions used by us only represents an estimate of savings you might benefit from buying certain tools with us compared to the major top brands and does not necessarily mean to cover all categories of tools offered by us. You are kindly reminded to verify carefully when you are placing an order with us if you are actually saving half in comparison with the top major brands.

VEVOR®

TOUGH TOOLS, HALF PRICE

PATIO GAZEBOS

KD-TY007-1

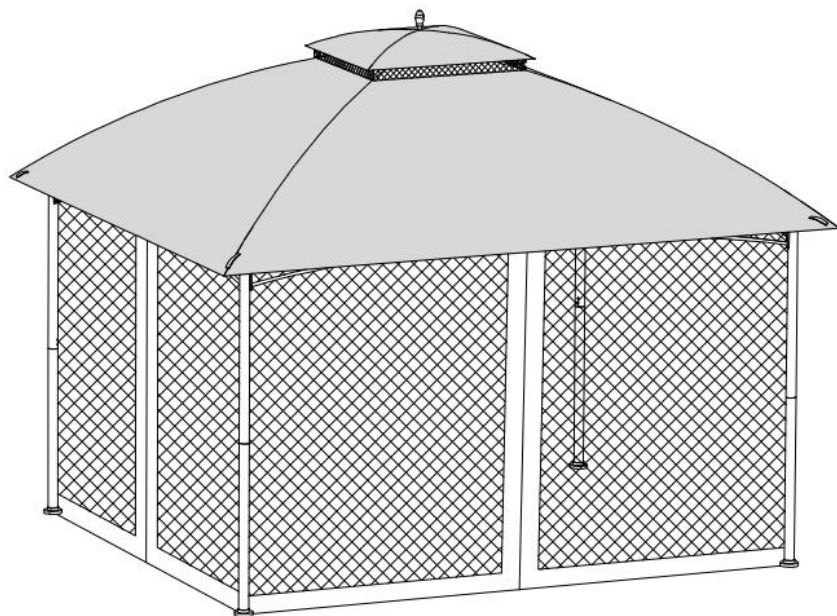

NEED HELP? CONTACT US!

Have product questions? Need technical support? Please feel free to contact us:

Technical Support and E-Warranty Certificate www.vevor.com/support

This is the original instruction, please read all manual instructions carefully before operating. VEVOR reserves a clear interpretation of our user manual. The appearance of the product shall be subject to the product you received. Please forgive us that we won't inform you again if there are any technology or software updates on our product.

ASSEMBLY AND SAFETY INSTRUCTIONS

Please pay close attention to the following instructions in order to reduce the risk of injuries, accidents or damage to the product by itself.

IMPORTANT

Please follow ALL safety instructions listed below.

Please remove the packaging material before assembling or using the product.

Please make sure that all listed parts are included in the package and that they are not damaged.

Please read these assembly and safety instructions carefully before usage of the tent and keep it for future reference.

This product should only be used in a non-commercial way.

SAFETY INFORMATION

The tent was not tested for wind and snow loads, unless that is clearly indicated otherwise. Therefore, these loads are not covered by guarantee. Please watch the weather forecasts to be able to properly protect or disassemble the tent before problems appear.

Tents should only be used as temporary accommodation and should be disassembled in adverse weather conditions.

Make sure to keep sufficient distance to houses as well as gas and power lines to avoid possible damage. Please check the area for power cables and gas lines. Ask your local authority for further information if needed.

When making use of suitable heaters, keep a minimum distance of 1.2 m to tarp material. Open fire or heaters with open flames such as patio heaters, umbrella heaters, gas heaters etc. should NOT be used inside the tent in any case.

The person taking care of the construction of the tent is responsible for adequately securing it to ensure its safety. Please check the anchoring constantly to avoid damage. A stable anchoring can extend the endurance of the tent.

In order to ensure your own safety, please make sure to wear gloves. The metal parts could have sharp edges and could be oily because of rust prevention treatment.

Please make sure that there is no permanent snow load. It should be removed right away. The same applies to rain and other forms of load.

Warning - please keep plastic and small spare parts out of children's reach. The thin film may cling to nose and mouth and prevent breathing.

ASSEMBLY & USAGE

Please reserve some more time for your first installation of the tent. The rules to be followed when pitching the tent are simple. Please use the illustrative instructions for each step of installation.

The screws joining the pipes with connectors must be tightened manually, using a hexagon key or an automatic screw driver, set at a max. level 2, to avoid material wear.

The tent should only be assembled by at least two adults. Please keep children away from the tent while assembling it to protect them.

Please make sure to find a flat and even ground base that is suitable for the assembly of the product and its intended usage.

Use only those materials provided with the tent upon delivery.

The tarps should not come into contact with any objects with sharp edges.

The tent can be used during temperatures close to zero. However, prior to such use, the tarp material must be stored at a temperature of at least 10°C. Please make sure that the tarp does not break when folded.

Each country has varying regulations regarding movable structures (tents) and unmovable structures. Please ask your local authorities whether a permission must be obtained to pitch the tent. In some countries, this depends on the size of the tent.

CARE & STORAGE INSTRUCTIONS

Any kind of damage due to acts of nature (weather damage) is not covered. The tent can be used during temperatures close to zero. However, prior to such use, the tarp material must be stored at a temperature of at least 10°C. Please make sure that the tarp does not break when folded.

Strong winds may damage the product. Please do not leave the gazebo unattended for an extensive amount of time.

Exposure to sunlight may cause the color of the tarp to fade out. This has no impact on the usability of the firepit and is not considered a product defect.

Heavy or extensive rain may lead to the accumulation of water pockets on the roof. These pockets need to be removed as soon as possible.

Please do not use aggressive chemicals to clean the tarp material. The best cleaning agent is water with a slightly alkaline reaction.

Do not make any modifications to the metal structure of the tent, such as for example, connecting and/or welding additional loads, making grooves and/or any deformations.

Please remove the tarp if the product is not in use to avoid damage.

We advise you to dismantle the pavilion during bad weather conditions and the winter season.

The tent / tarp should only be folded, packed and stored when fully dry. Please do not put any other objects on top of the tent / tarp when stored.

SPECIFICATIONS

Model	KD-TY007-1
Product Size	2970×3920×3530mm
Color	Beige/Brown/Black

TOOLS

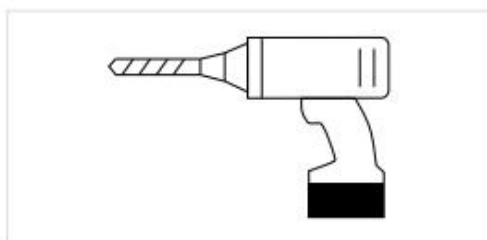





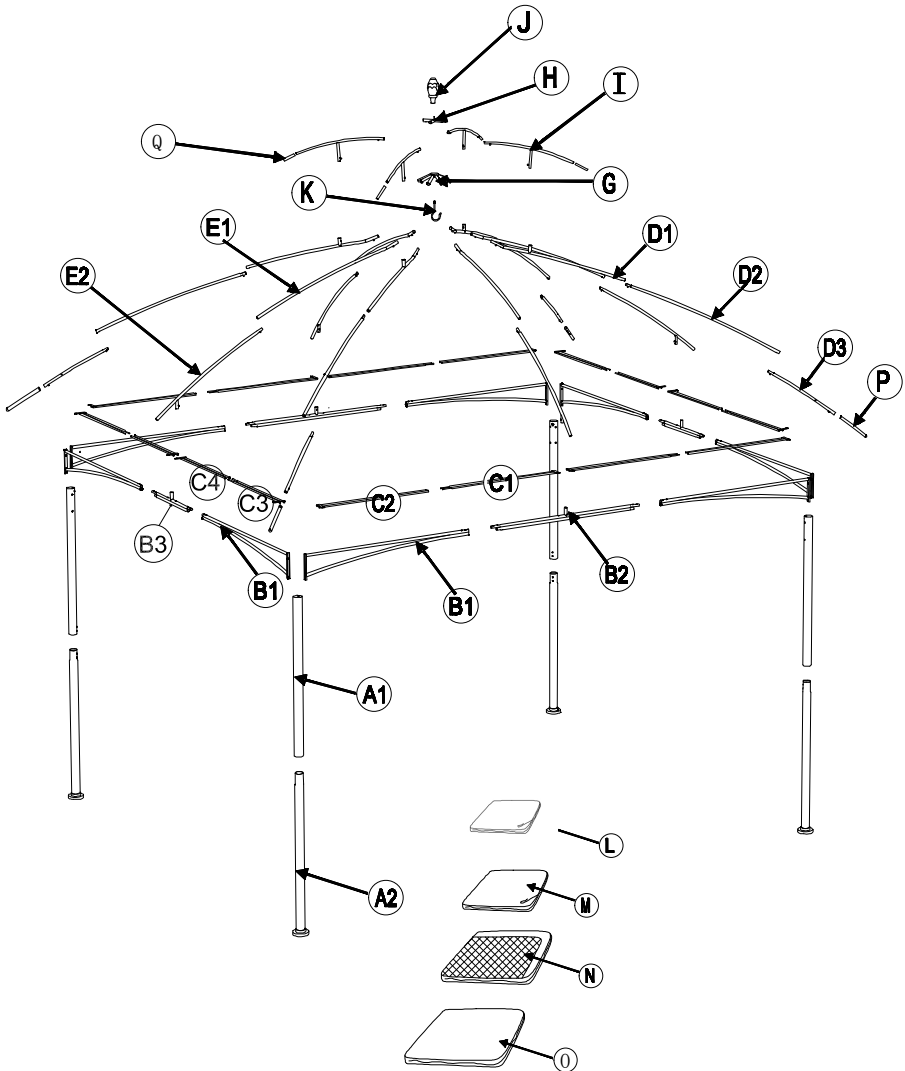
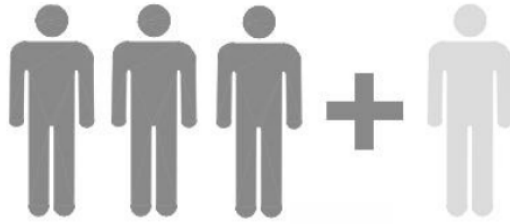



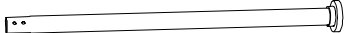















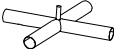

IMPORTANT





People needed for installation work

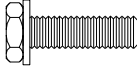

Parts List

Label	Qty	Part Image
A1	4	
A2	4	
B1	8	
B2	2	
B3	2	
C1	4	
C2	4	
C3	4	
C4	4	
D1	4	
D2	4	
D3	4	
E1	2	
E2	2	
F1	2	
F2	2	
G	1	
H	1	

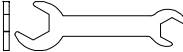
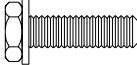
Parts list		
Label1	Qty	Parts Image
I	4	
J	1	
K	1	
L	1	
M	1	
N	1	
P	4	
O	1	
Q	4	

Parts list				
Label1	Description	Qty	Add	Parts Image
AA	M5*15	24	2	
BB	M6*20	40	2	
CC	Φ8*180	8	0	
DD	/	104	3	
EE	M5/M6	1	0	
FF	M6*35	4	1	
GG	M6	4	1	

1

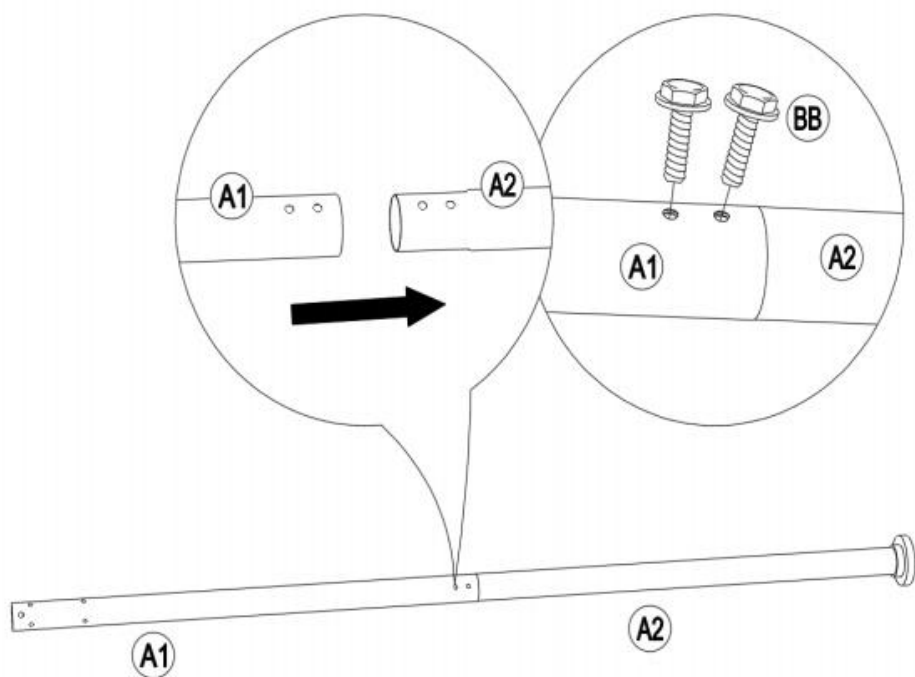
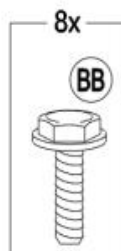
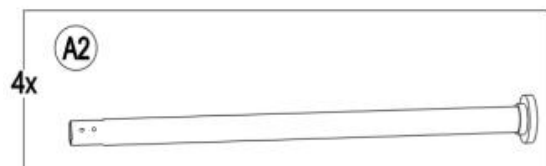

2

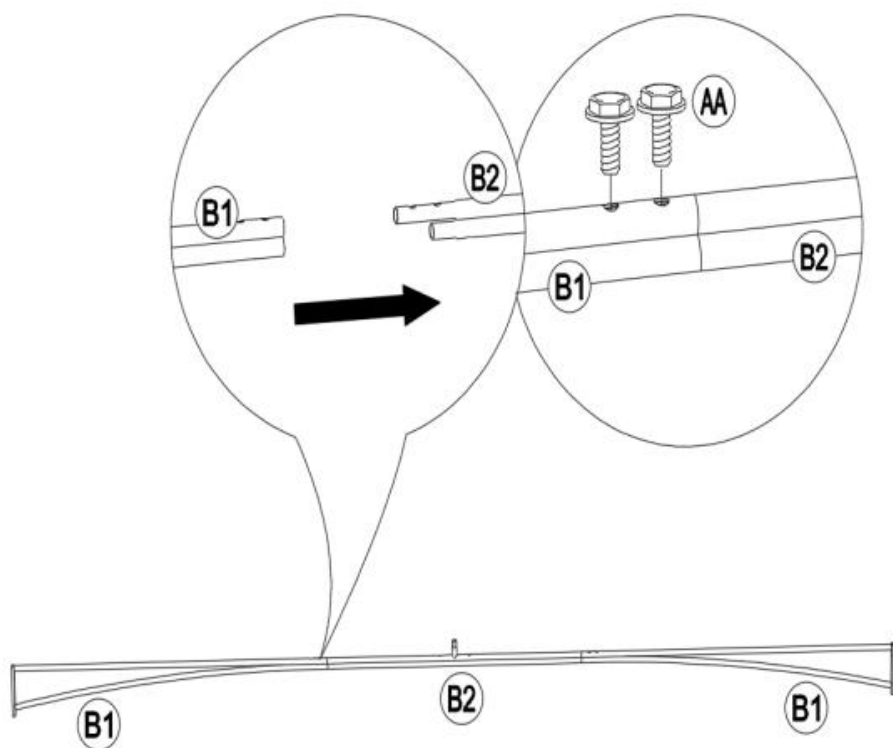
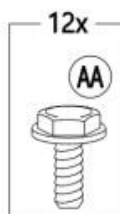
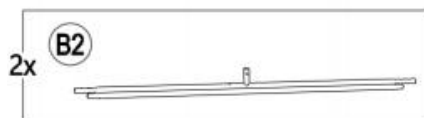
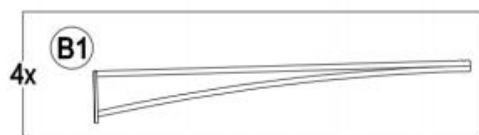

3

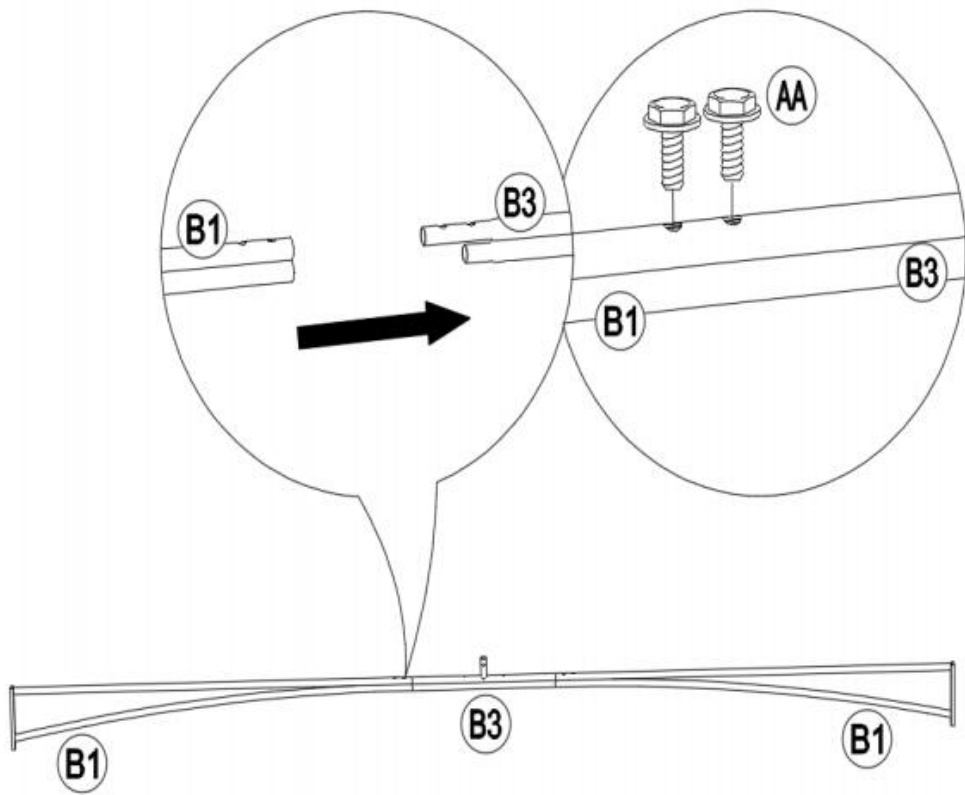
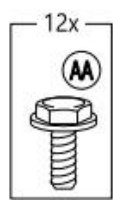
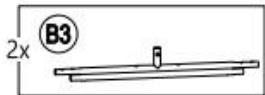
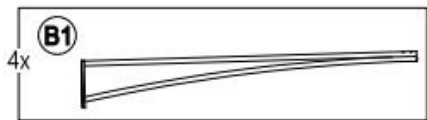

4

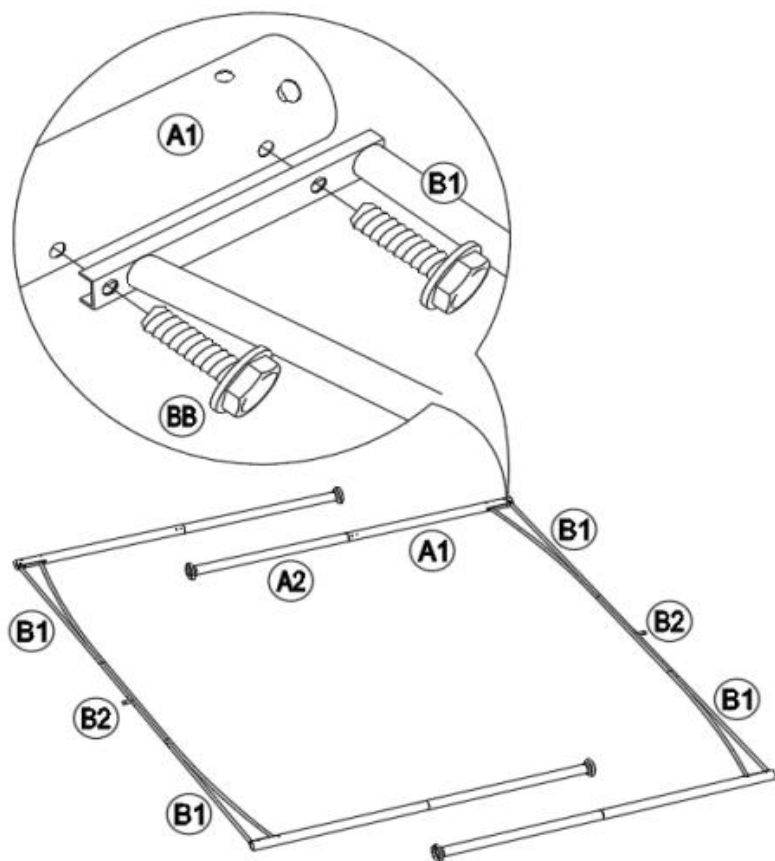
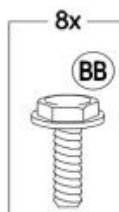
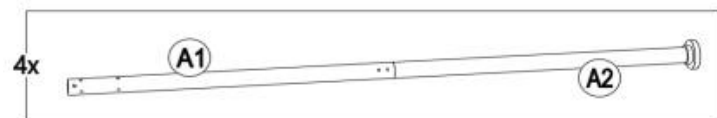
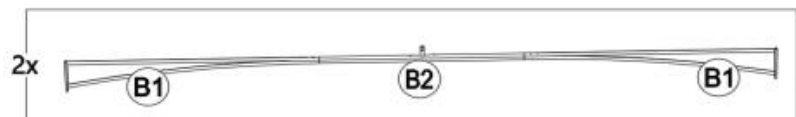

5

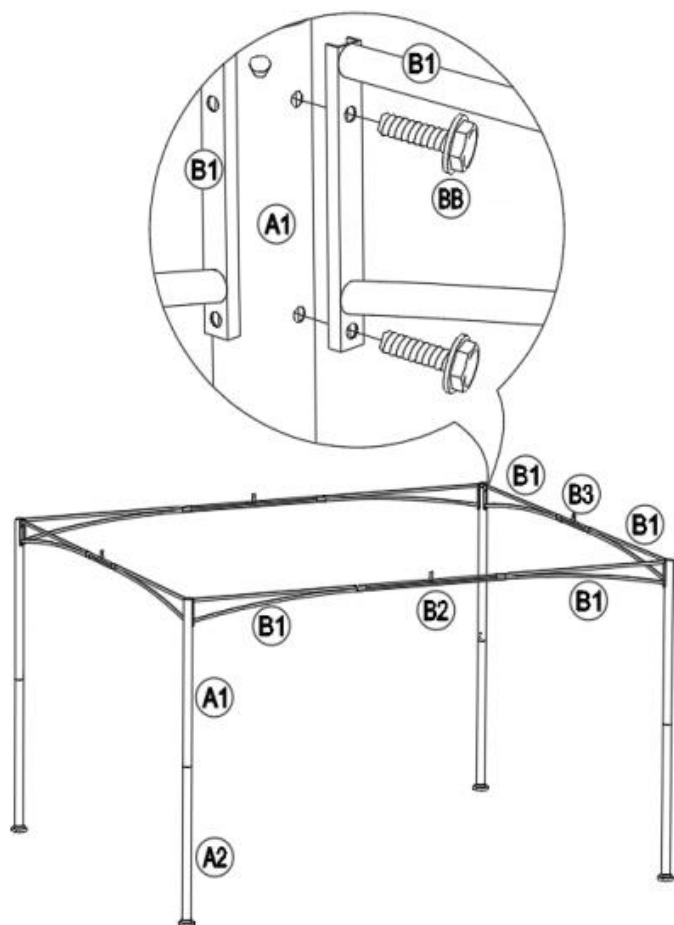
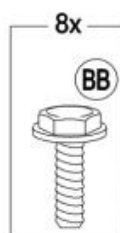
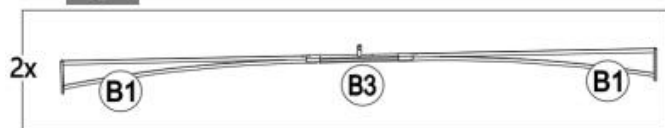

6

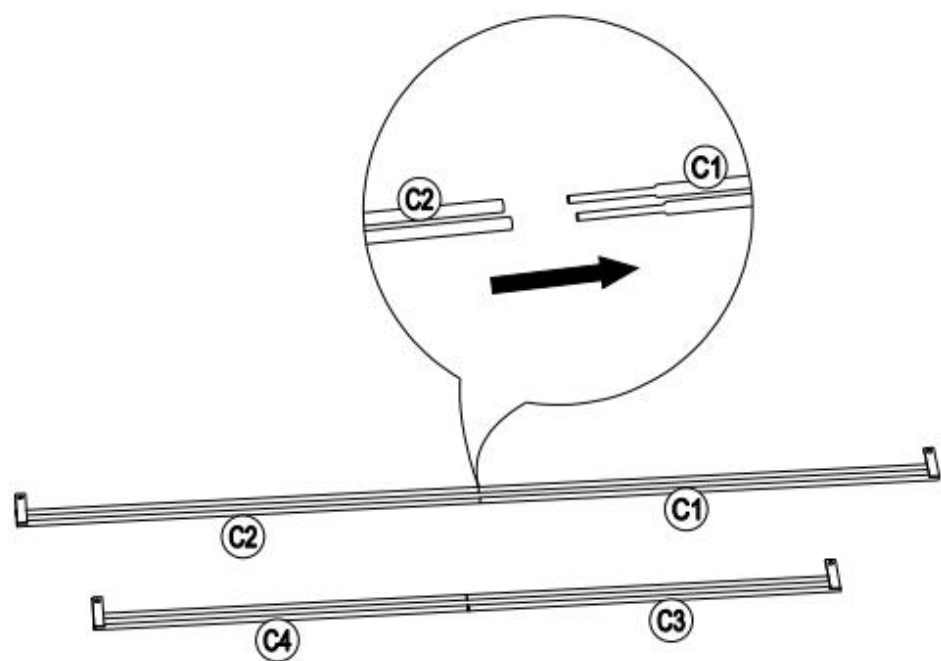

7

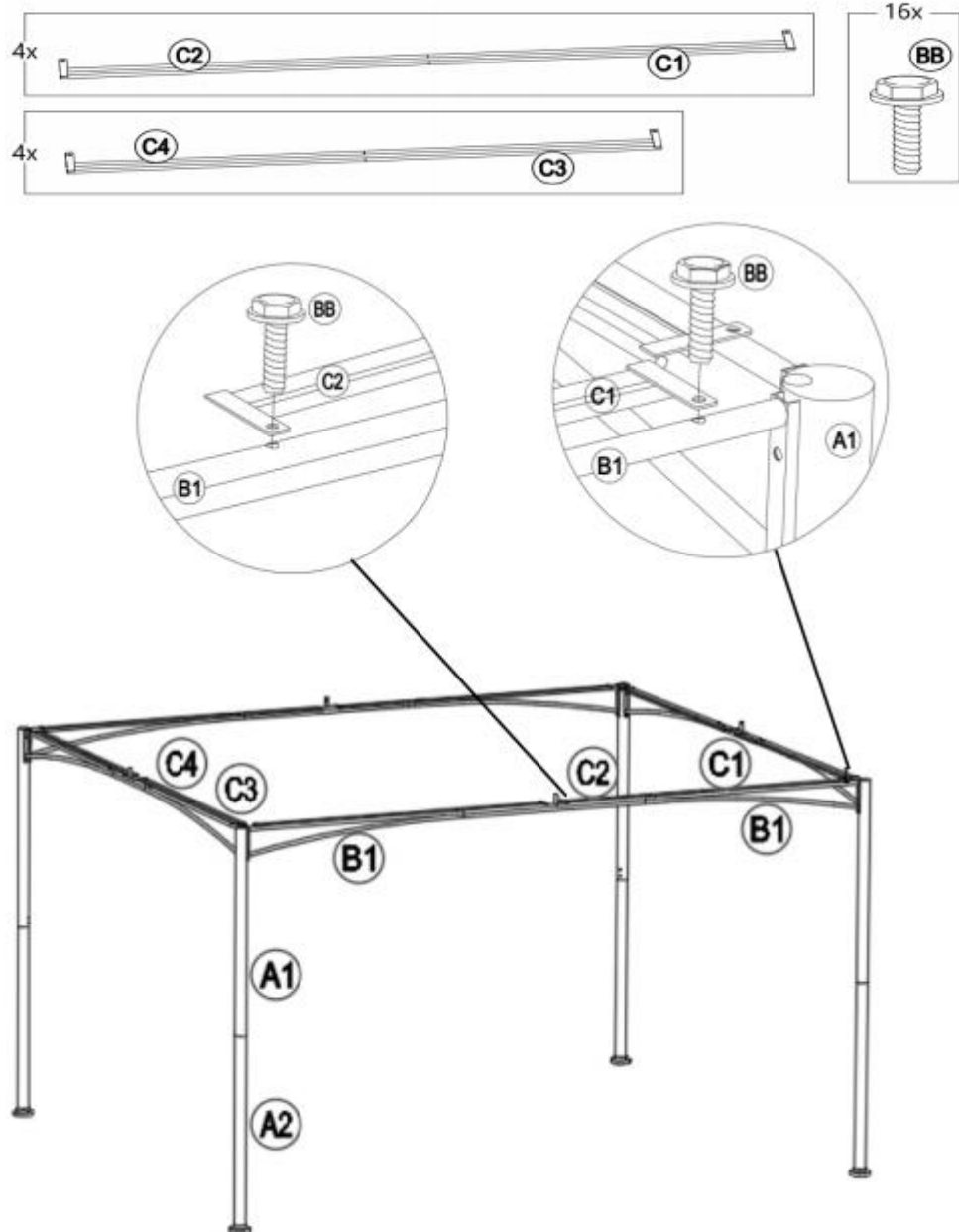

8

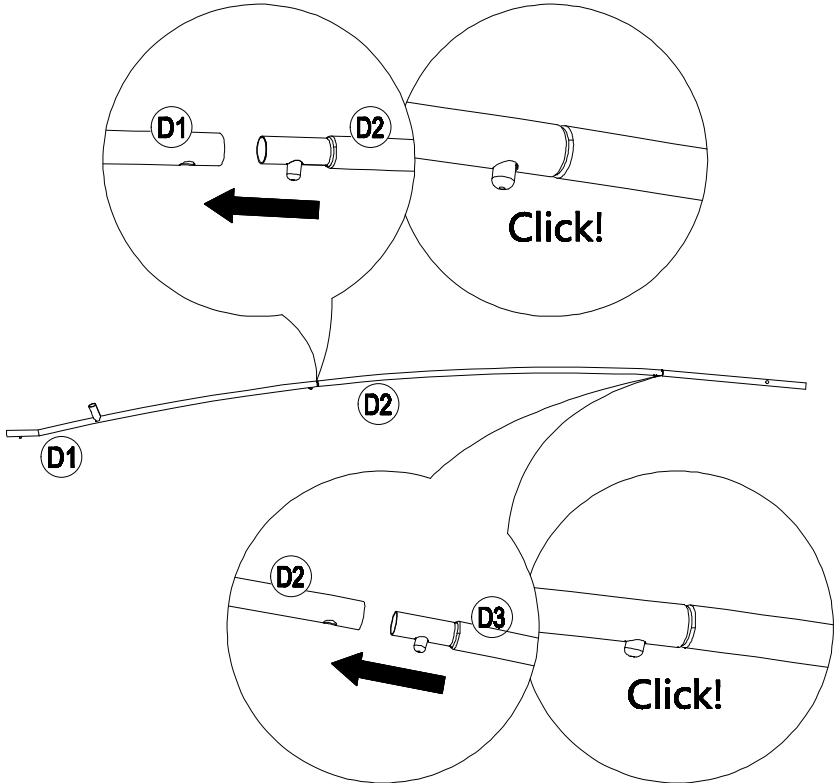
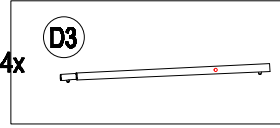
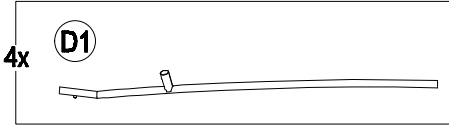

9

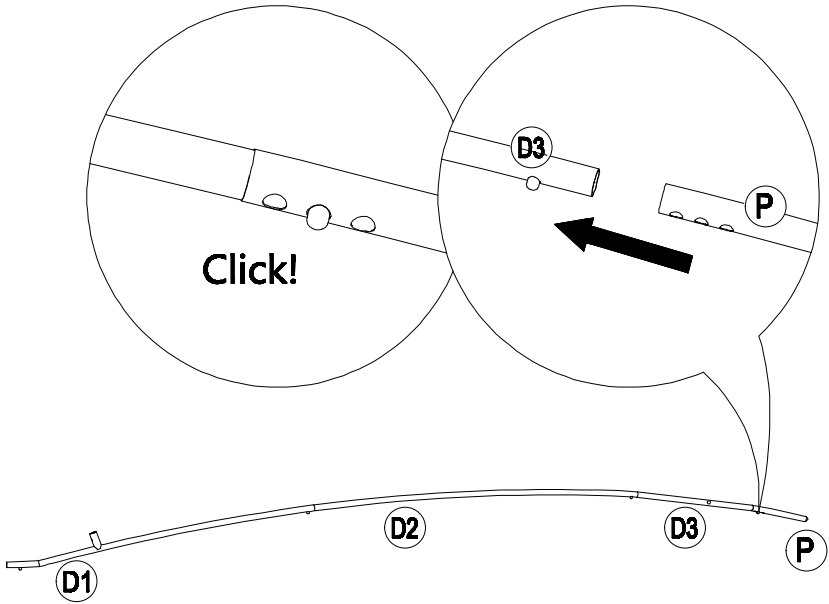
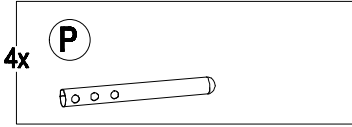

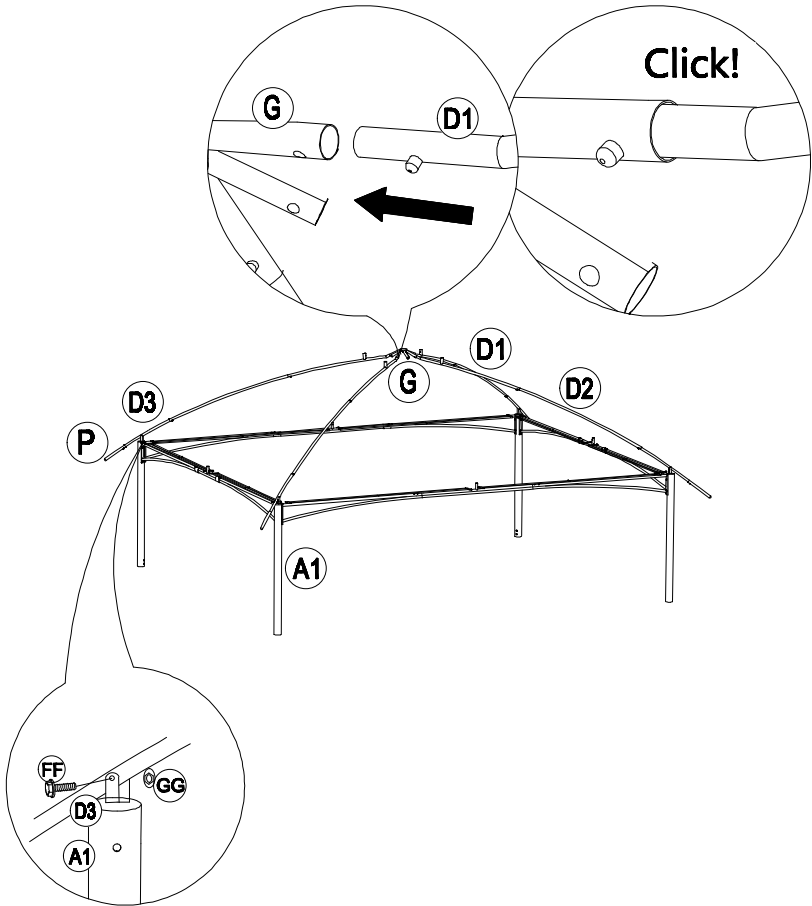
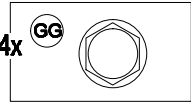
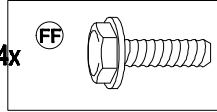
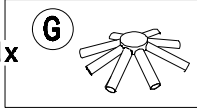
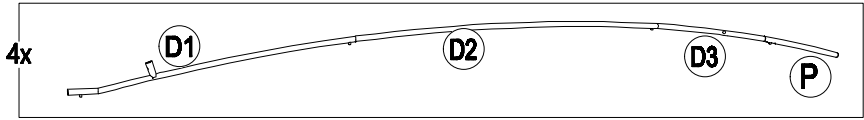

11

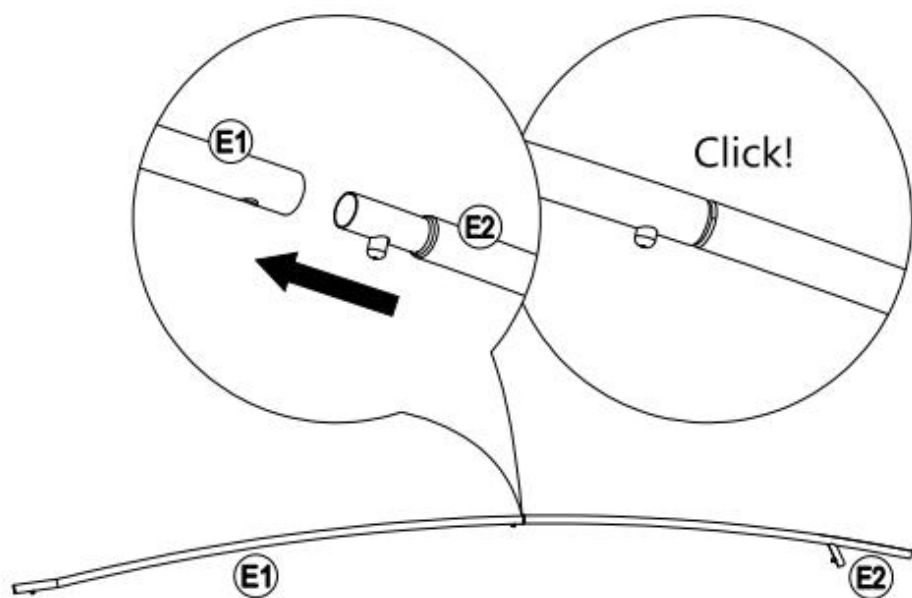

12

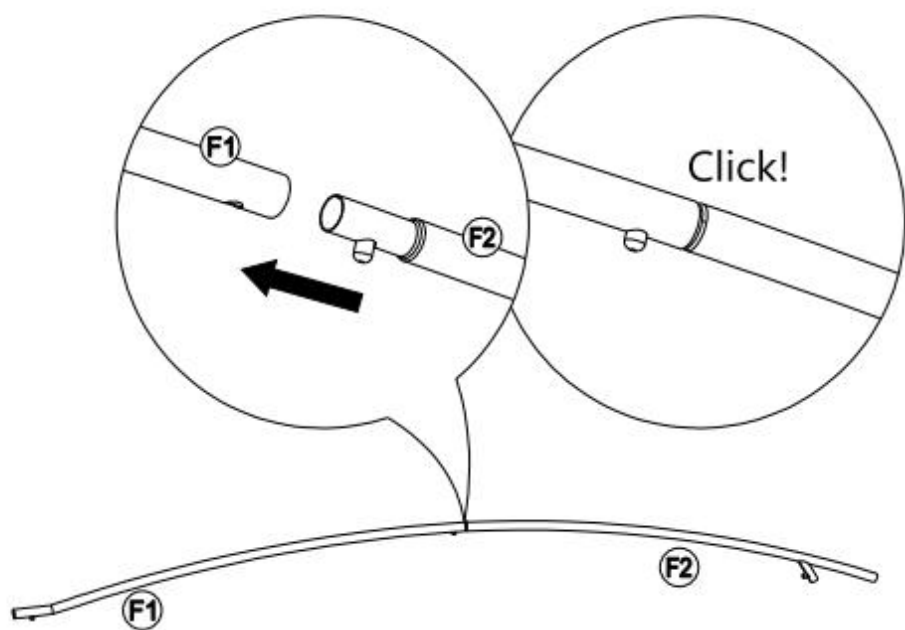

13

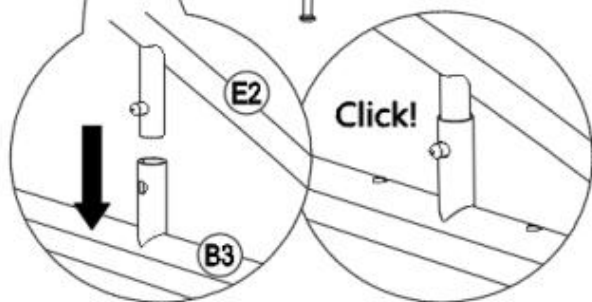
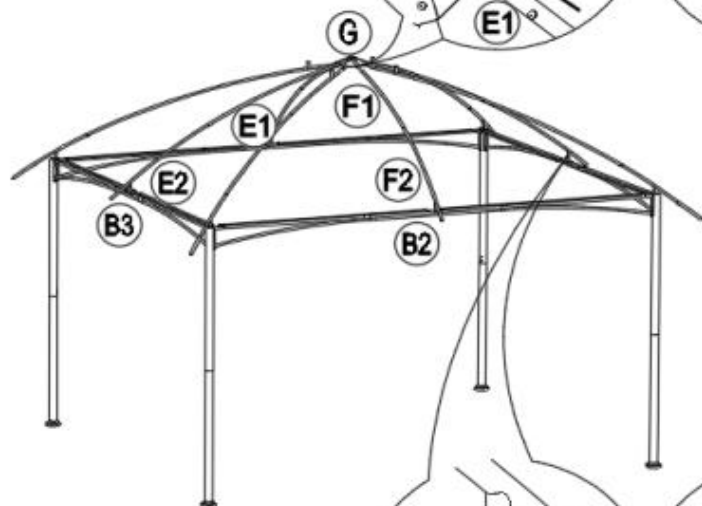
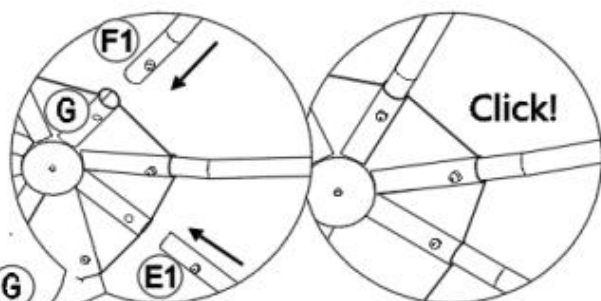
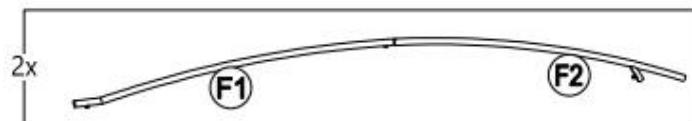
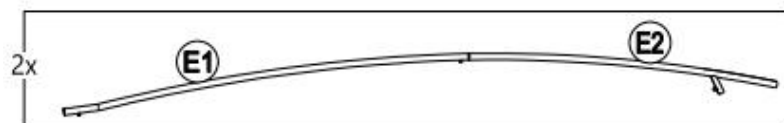

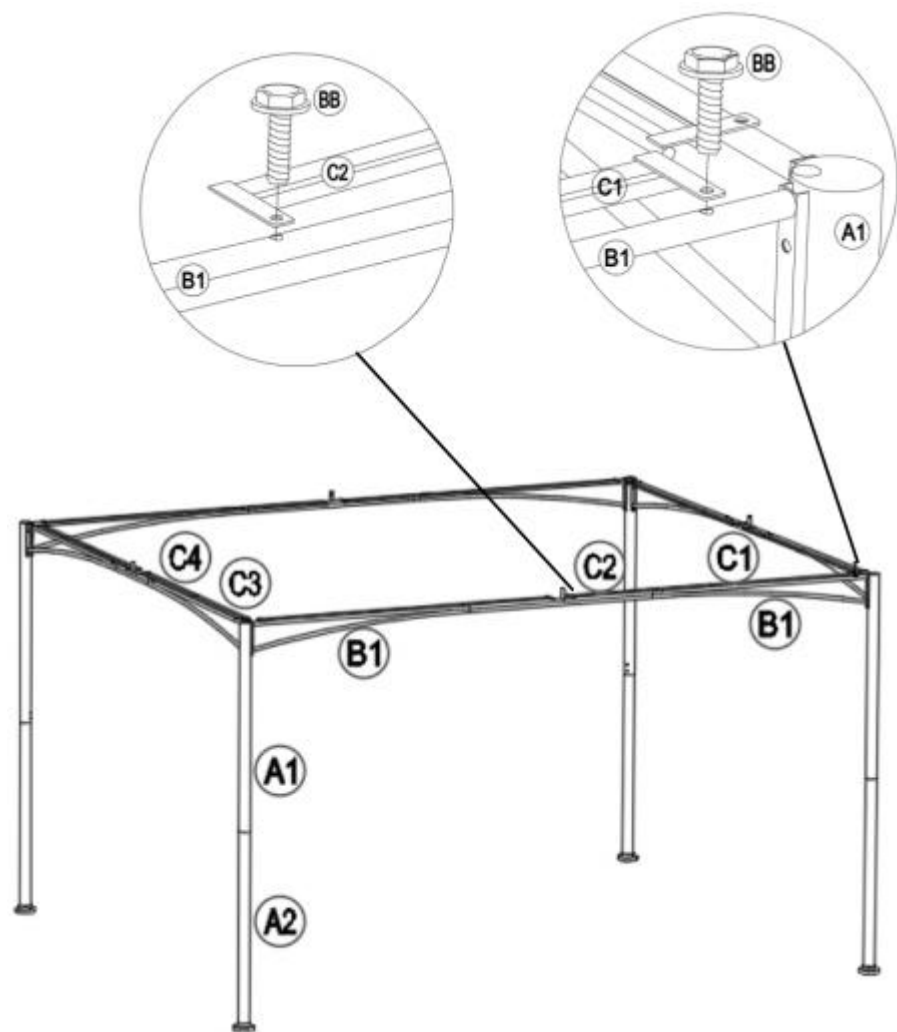

14

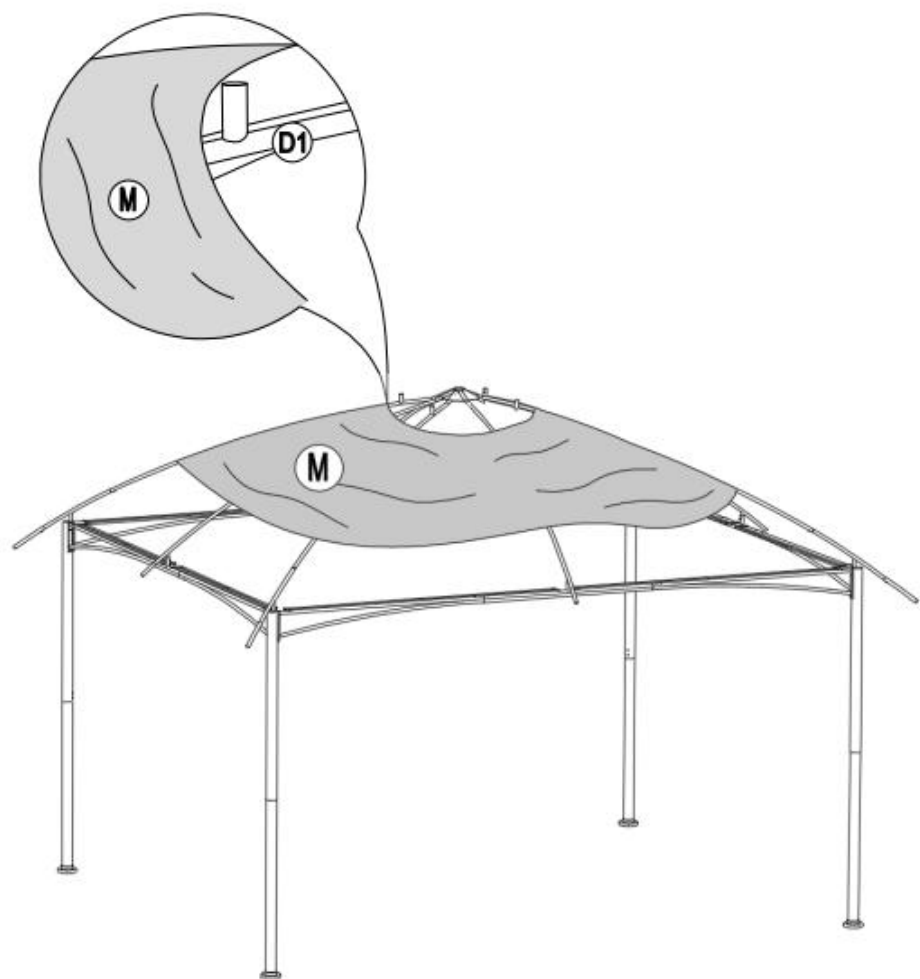
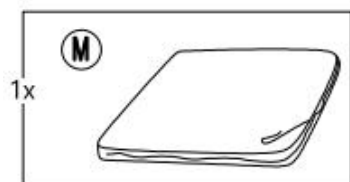

15

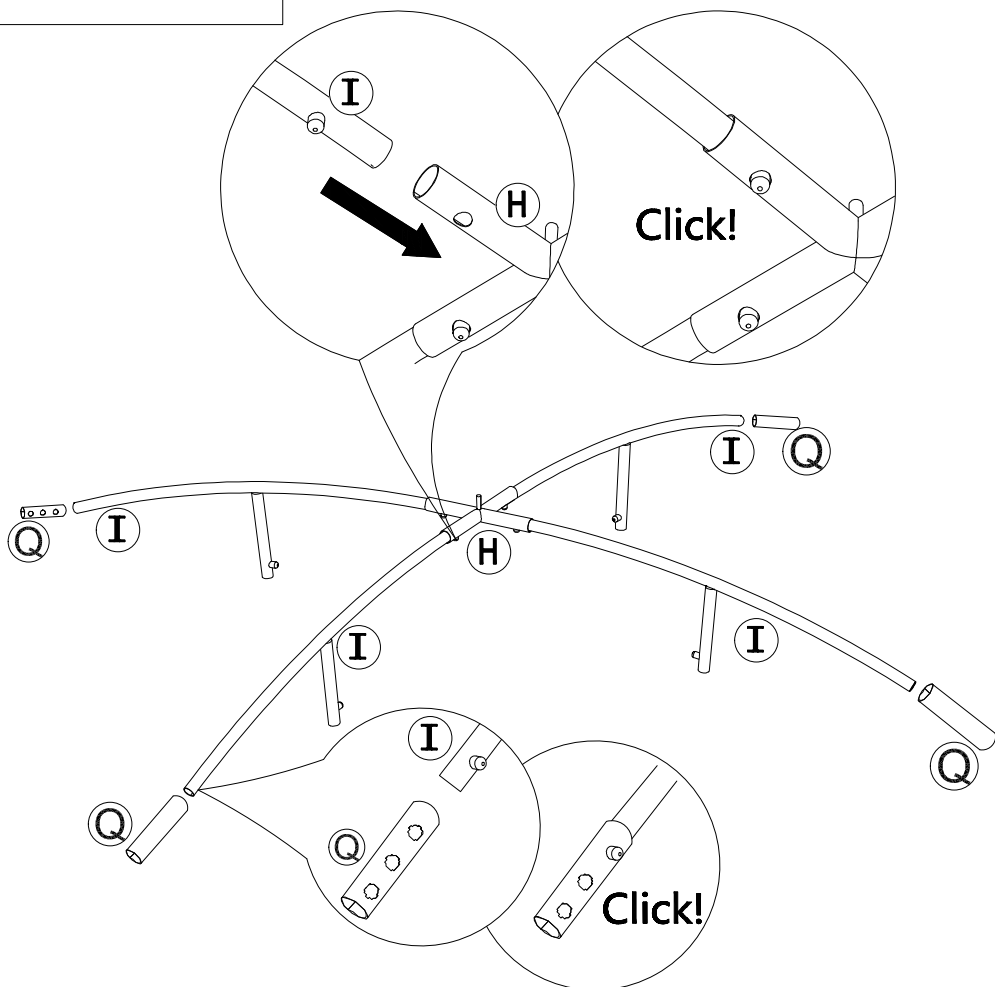
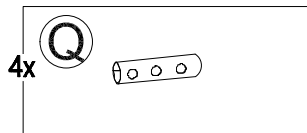
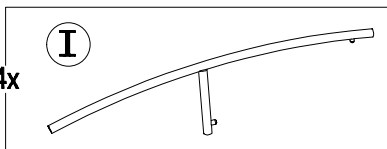
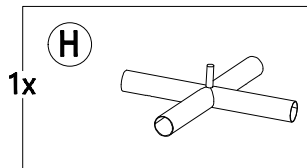

16

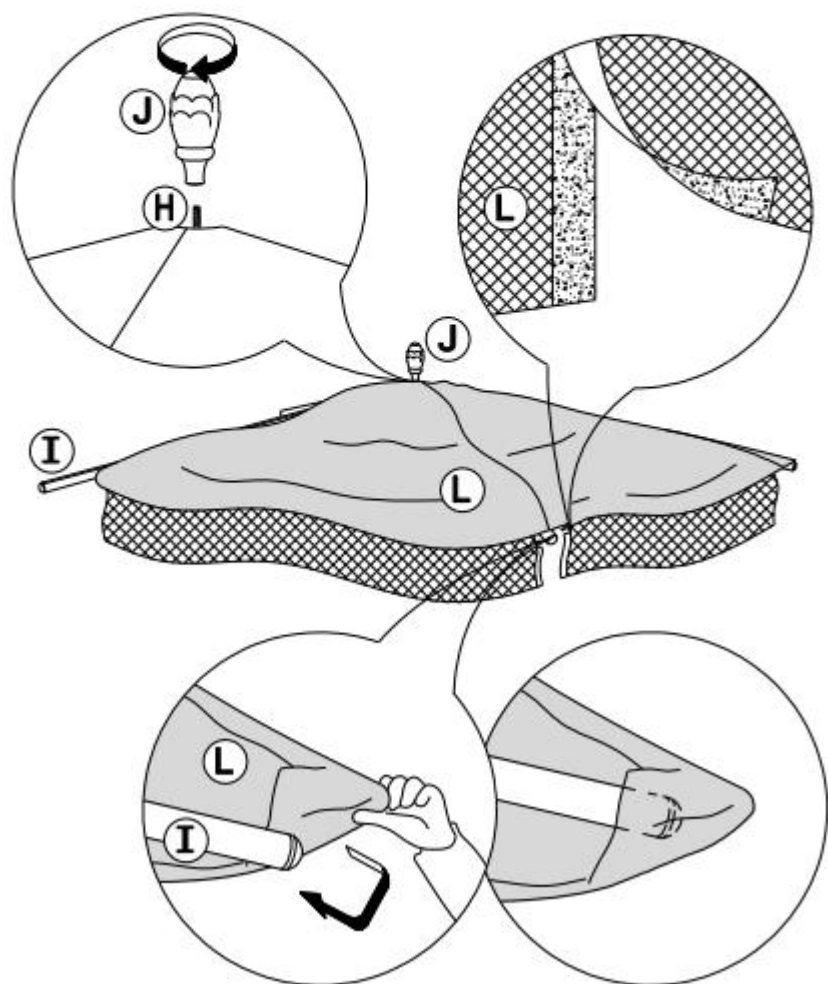
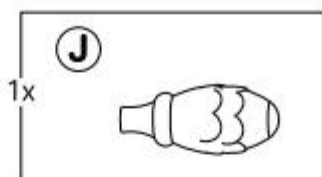
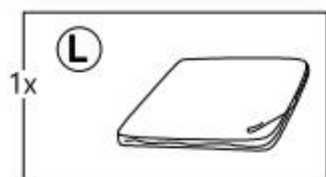

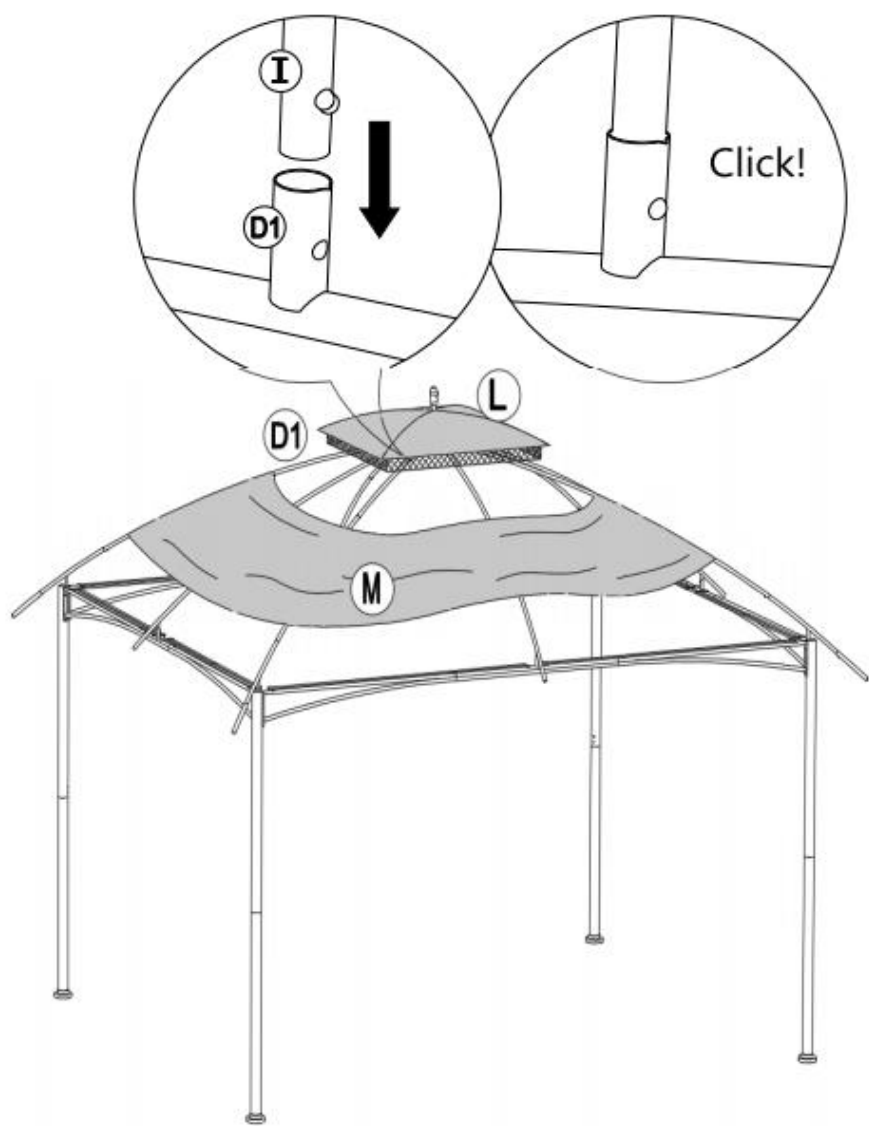

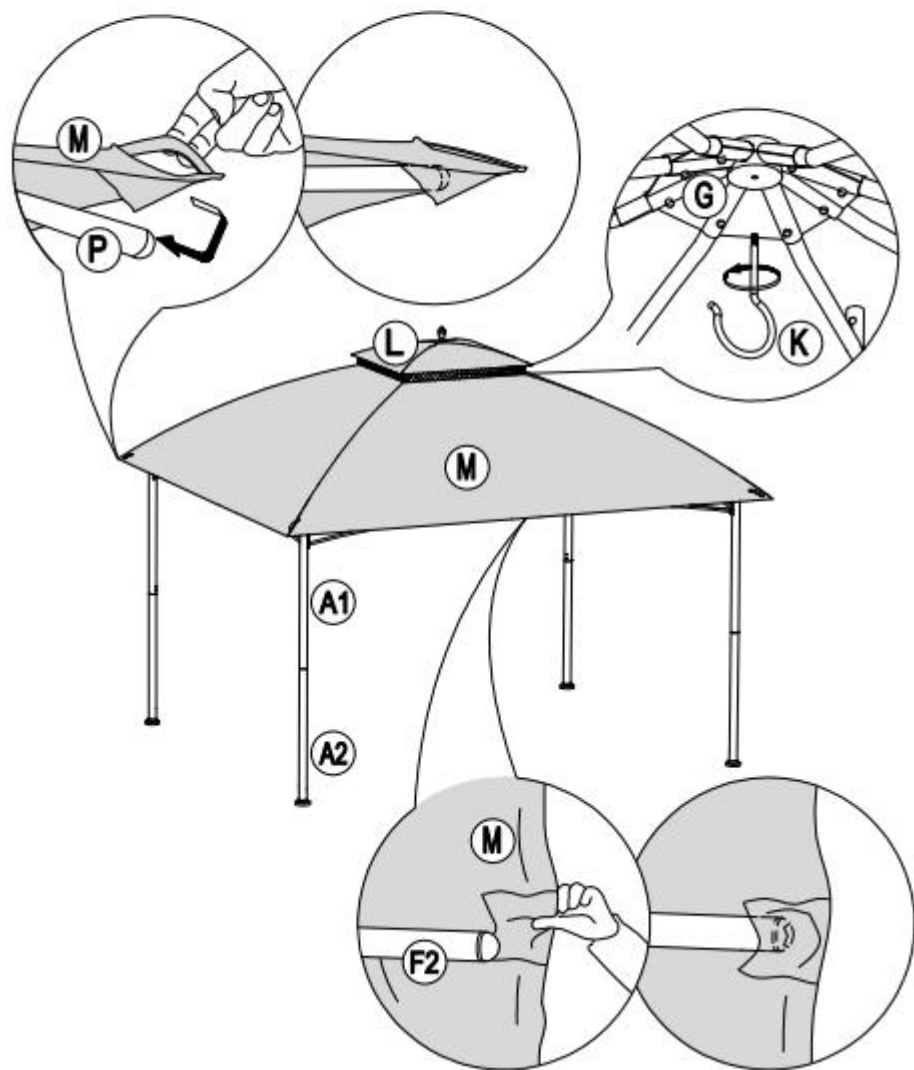
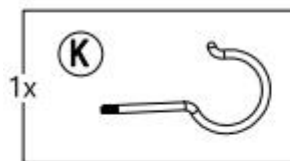

19

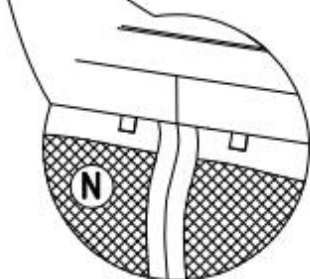
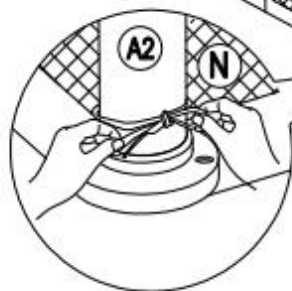
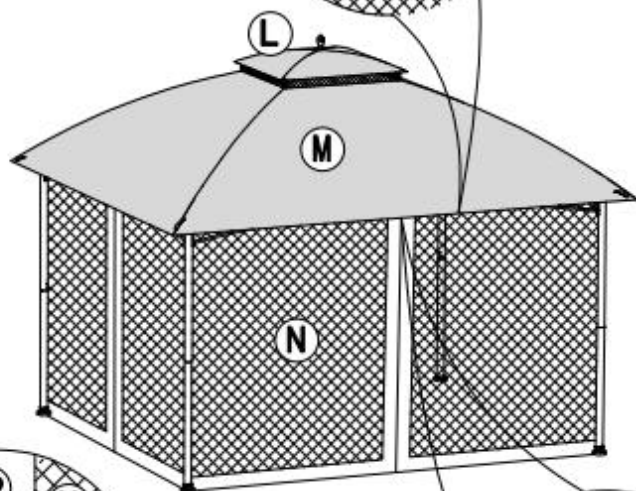
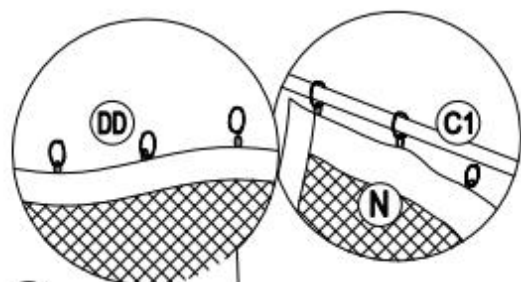
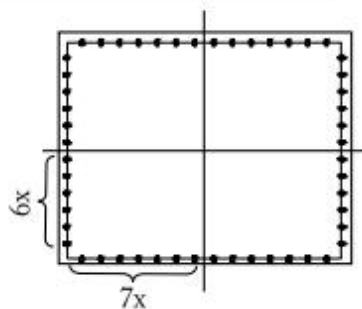
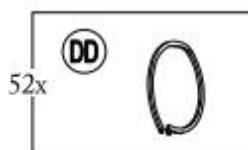
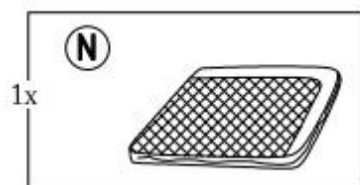

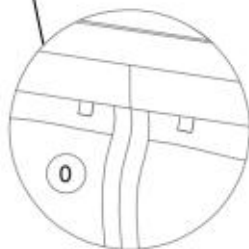
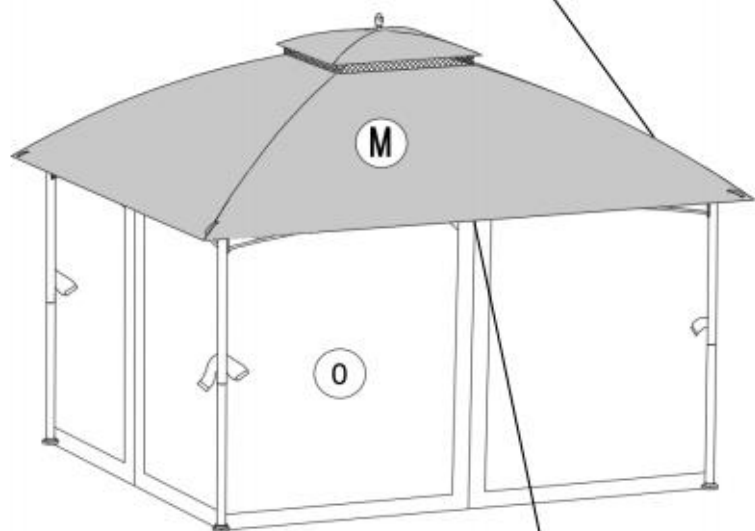
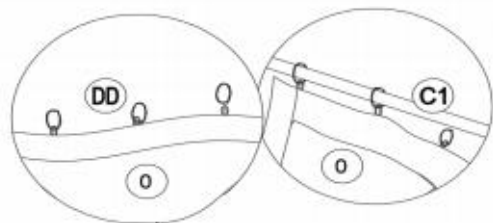
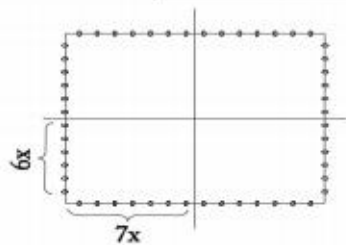
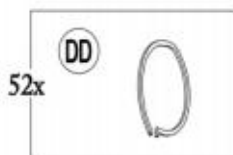
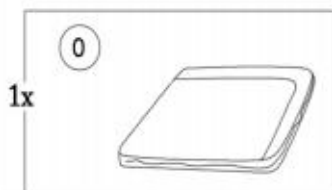

21

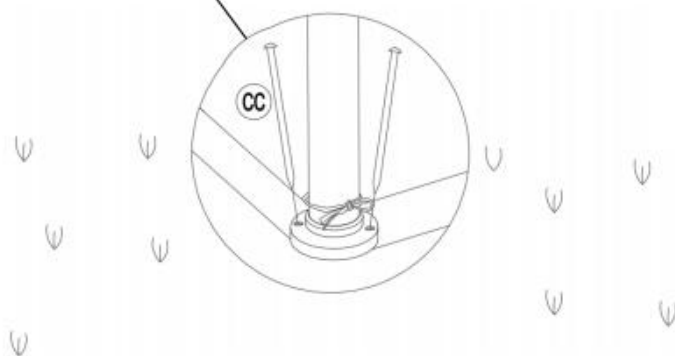
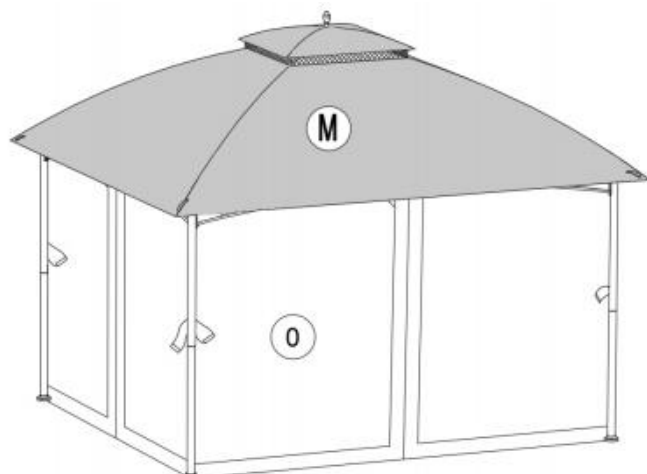

Imported to USA: Sanven Technology Ltd.
Suite 250, 9166 Anaheim Place, Rancho Cucamonga, CA 91730

VEVOR[®]

TOUGH TOOLS, HALF PRICE

Technical Support and E-Warranty Certificate

www.vevor.com/support

VEVOR[®]

TOUGH TOOLS, HALF PRICE

Technischer Support und E-Garantie-Zertifikat www.vevor.com/support

ANLEITUNG FÜR TERRASSENPAVILLONS

MODELL:KD-TY007-1

Wir sind weiterhin bestrebt, Ihnen Werkzeuge zu wettbewerbsfähigen Preisen anzubieten.

„Sparen Sie die Hälfte“, „Halber Preis“ oder andere ähnliche Ausdrücke, die wir verwenden, stellen nur eine Schätzung der Ersparnis dar, die Sie beim Kauf bestimmter Werkzeuge bei uns im Vergleich zu den großen Topmarken erzielen können, und decken nicht unbedingt alle von uns angebotenen Werkzeugkategorien ab. Wir

möchten Sie freundlich daran erinnern, bei der Bestellung bei uns sorgfältig zu prüfen, ob Sie im Vergleich zu den großen Topmarken tatsächlich die Hälfte sparen.

VEVOR®

TOUGH TOOLS, HALF PRICE

TERRASSENPAVILLONS

KD-TY007-1

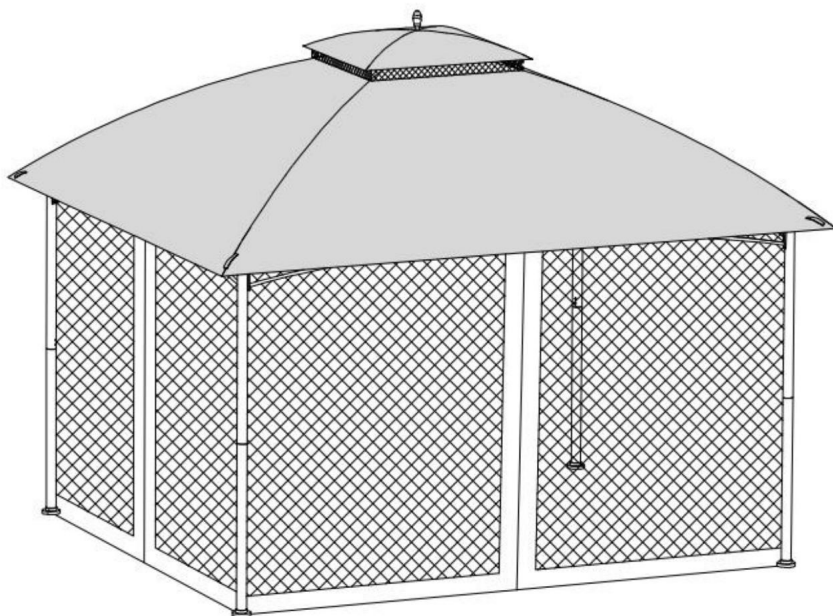

Brauchen Sie Hilfe? Kontaktieren Sie uns!

Sie haben Fragen zu unseren Produkten? Sie benötigen technischen Support? Dann kontaktieren Sie uns gerne:

Technischer Support und E-Garantie-Zertifikat www.vevor.com/support

Dies ist die Originalanleitung. Bitte lesen Sie alle Anweisungen sorgfältig durch, bevor Sie das Gerät in Betrieb nehmen. VEVOR behält sich eine klare Auslegung unserer Bedienungsanleitung vor. Das Erscheinungsbild des Produkts richtet sich nach dem Produkt, das Sie erhalten haben. Bitte verzeihen Sie uns, dass wir Sie nicht erneut informieren, wenn es Technologie- oder Software-Updates für unser Produkt gibt.

MONTAGE- UND SICHERHEITSHINWEISE

Bitte beachten Sie die folgenden Hinweise genau, um das Risiko zu verringern von Verletzungen, Unfällen oder Schäden am Produkt selbst.

WICHTIG

Bitte befolgen Sie ALLE unten aufgeführten Sicherheitshinweise.

Bitte entfernen Sie vor der Montage und Inbetriebnahme des Produktes das Verpackungsmaterial.

Bitte achten Sie darauf, dass alle aufgeführten Teile im Lieferumfang enthalten sind und nicht beschädigt.

Bitte lesen Sie diese Montage- und Sicherheitshinweise vor der Inbetriebnahme des Zelt und bewahren Sie es zum späteren Nachschlagen auf.

Dieses Produkt darf nur für nicht-kommerzielle Zwecke verwendet werden.

SICHERHEITSHINWEISE

Das Zelt wurde nicht auf Wind- und Schneelasten getestet, es sei denn, dies ist ausdrücklich angegeben andernfalls. Daher fallen diese Lasten nicht unter die Garantie. Bitte beachten Sie die Wettervorhersagen, um das Zelt vor dem Aufstellen richtig schützen oder abbauen zu können Es treten Probleme auf.

Zelte sollten nur als vorübergehende Unterkunft genutzt werden und bei widrigen Witterungsbedingungen demontiert.

Halten Sie ausreichend Abstand zu Häusern sowie Gas- und Stromleitungen, um um mögliche Schäden zu vermeiden. Bitte kontrollieren Sie den Bereich auf Stromkabel und Gasleitungen.

Bitte erkundigen Sie sich bei Bedarf bei Ihrer Gemeindeverwaltung nach weiteren Informationen.

Bei Verwendung geeigneter Heizgeräte ist ein Mindestabstand von 1,2 m zur Plane einzuhalten Material. Offenes Feuer oder Heizgeräte mit offener Flamme wie Terrassenheizer, Sonnenschirm Heizgeräte, Gasheizungen etc. dürfen im Zelt auf keinen Fall verwendet werden.

Die Person, die den Aufbau des Zeltes übernimmt, ist verantwortlich für die ausreichende Sichern Sie es, um seine Sicherheit zu gewährleisten. Bitte überprüfen Sie die Verankerung ständig, um zu vermeiden Beschädigungen. Eine stabile Verankerung kann die Lebensdauer des Zeltes verlängern.

Zu Ihrer eigenen Sicherheit tragen Sie bitte unbedingt Handschuhe.
Die Metallteile können scharfkantig sein und durch Rost ölig werden
Präventionsbehandlung.

Bitte achten Sie darauf, dass keine permanente Schneelast vorhanden ist. Diese sollte entfernt werden
Dasselbe gilt auch für Regen und andere Belastungen.

Achtung - bitte bewahren Sie Kunststoff- und Kleinteile außerhalb der Reichweite von Kindern auf.
Ein dünner Film kann an Nase und Mund haften bleiben und die Atmung behindern.

MONTAGE & VERWENDUNG

Bitte planen Sie für den ersten Aufbau des Zeltes etwas mehr Zeit ein. Die zu beachtenden Regeln
Die Schritte beim Aufstellen des Zeltes sind einfach. Bitte verwenden Sie die bebilderte Anleitung
für jeden Installationsschritt.

Die Schrauben, die die Rohre mit den Verbindungsstücken verbinden, müssen von Hand angezogen werden, mit einem
Sechskantschlüssel oder automatischer Schraubendreher, max. auf Stufe 2 eingestellt, um Materialverlust zu vermeiden.
tragen.

Das Zelt sollte nur von mindestens zwei Erwachsenen aufgebaut werden. Bitte halten Sie Kinder
Halten Sie diese beim Aufbau vom Zelt fern, um sie zu schützen.

Bitte achten Sie auf einen flachen und ebenen Untergrund, der für die
Montage des Produkts und seine bestimmungsgemäße Verwendung.

Verwenden Sie nur die Materialien, die bei der Lieferung des Zeltes mitgeliefert wurden.

Die Planen dürfen nicht mit scharfkantigen Gegenständen in Berührung kommen.

Das Zelt kann bei Temperaturen nahe Null verwendet werden. Vor solchen
Das Planenmaterial muss bei einer Temperatur von mindestens 10 °C gelagert werden. Bitte
Achten Sie darauf, dass die Plane beim Zusammenfallen nicht reißt.

In jedem Land gelten unterschiedliche Bestimmungen für bewegliche Bauten (Zelte) und
unbewegliche Bauten. Bitte erkundigen Sie sich bei Ihrer örtlichen Behörde, ob eine Genehmigung
muss zum Aufstellen des Zeltes eingeholt werden. In einigen Ländern hängt dies von der Größe des
das Zelt.

PFLEGE- UND LAGERHINWEISE

Schäden jeglicher Art, die auf höhere Gewalt (Wetterschäden) zurückzuführen sind, sind nicht versichert.
Das Zelt kann bei Temperaturen nahe Null verwendet werden. Vor solchen
Verwendung muss das Planenmaterial bei einer Temperatur von mindestens 10°C gelagert werden. Bitte
Achten Sie darauf, dass die Plane beim Zusammenfallen nicht reißt.

Starke Winde können das Produkt beschädigen. Bitte verlassen Sie den Pavillon nicht
längere Zeit unbeaufsichtigt.

Sonneneinstrahlung kann dazu führen, dass die Farbe der Plane verblasst. Dies hat keine
Auswirkungen auf die Gebrauchstauglichkeit der Feuerstelle und gilt nicht als Produktfehler.

Bei starkem oder langanhaltendem Regen kann es zur Bildung von Wassersäcken auf dem Dach kommen.
Diese Taschen müssen so schnell wie möglich entfernt werden.

Bitte verwenden Sie keine aggressiven Chemikalien zum Reinigen des Planenmaterials.
Reinigungsmittel ist leicht alkalisch reagierendes Wasser.

Nehmen Sie keine Veränderungen an der Metallstruktur des Zeltes vor, wie z.B.
beispielsweise das Anschließen und/oder Schweißen von Zusatzlasten, das Herstellen von Nuten und/oder
Verformungen.

Bitte entfernen Sie die Plane, wenn das Produkt nicht verwendet wird, um Schäden zu vermeiden.

Wir empfehlen Ihnen, den Pavillon bei schlechtem Wetter abzubauen und die Wintersaison.

Das Zelt/die Plane sollte erst gefaltet, verpackt und gelagert werden, wenn es vollständig trocken ist. Legen Sie während der Lagerung keine anderen Gegenstände auf das Zelt/die Plane.

Spezifikationen

Model	KD-TY007-1
Product Size	2970×3920×3530mm
Color	Beige/Brown/Black

WERKZEUGE

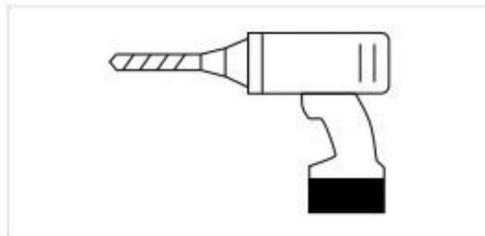





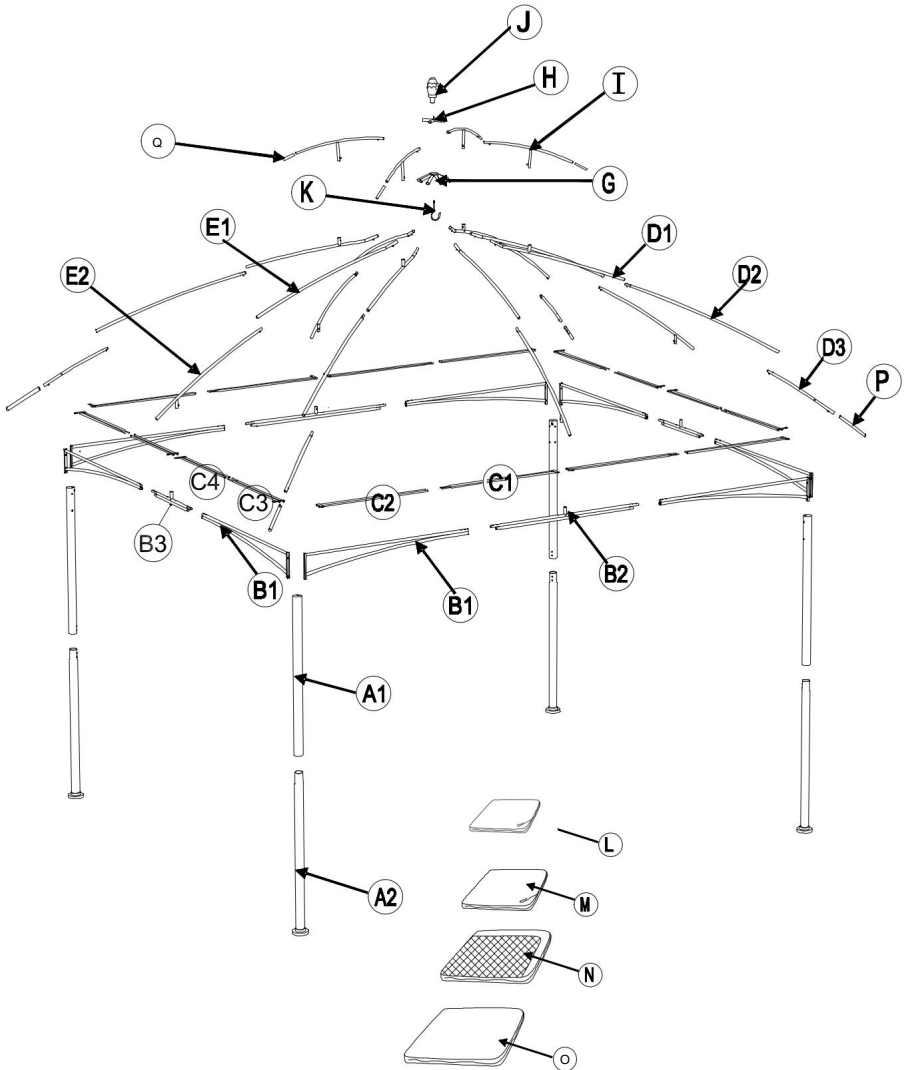
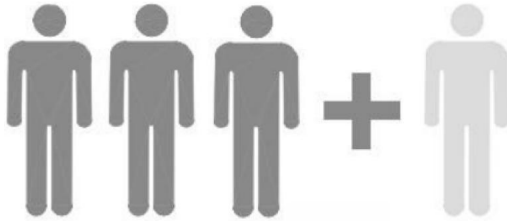





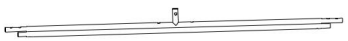
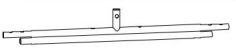









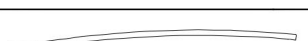
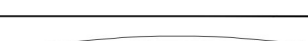



IMPORTANT





People needed for installation work

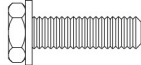
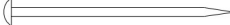

Parts List

Label	Qty	Part Image
A1	4	
A2	4	
B1	8	
B2	2	
B3	2	
C1	4	
C2	4	
C3	4	
C4	4	
D1	4	
D2	4	
D3	4	
E1	2	
E2	2	
F1	2	
F2	2	
G	1	
H	1	

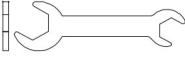
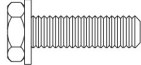
Parts list		
Label	Qty	Parts Image
I	4	
J	1	
K	1	
L	1	
M	1	
N	1	
P	4	
O	1	
Q	4	

Parts list				
Label	Description	Qty	Add	Parts Image
AA	M5*15	24	2	
BB	M6*20	40	2	
CC	Φ8*180	8	0	
DD	/	104	3	
EE	M5/M6	1	0	
FF	M6*35	4	1	
GG	M6	4	1	

1

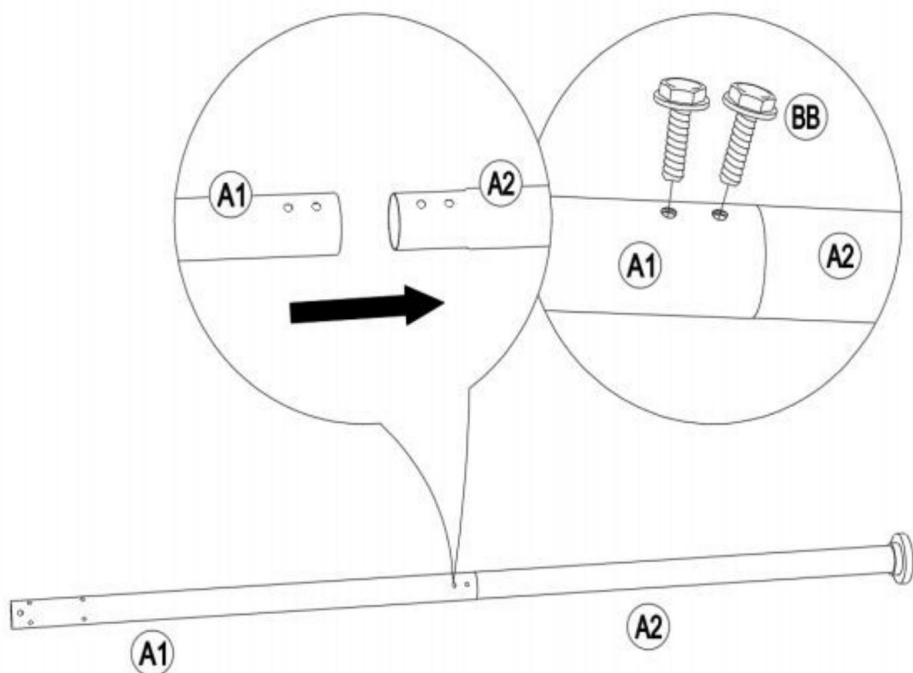
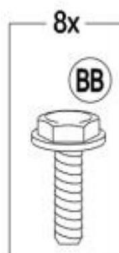
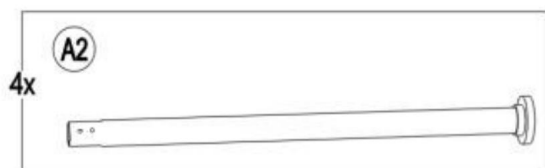

2

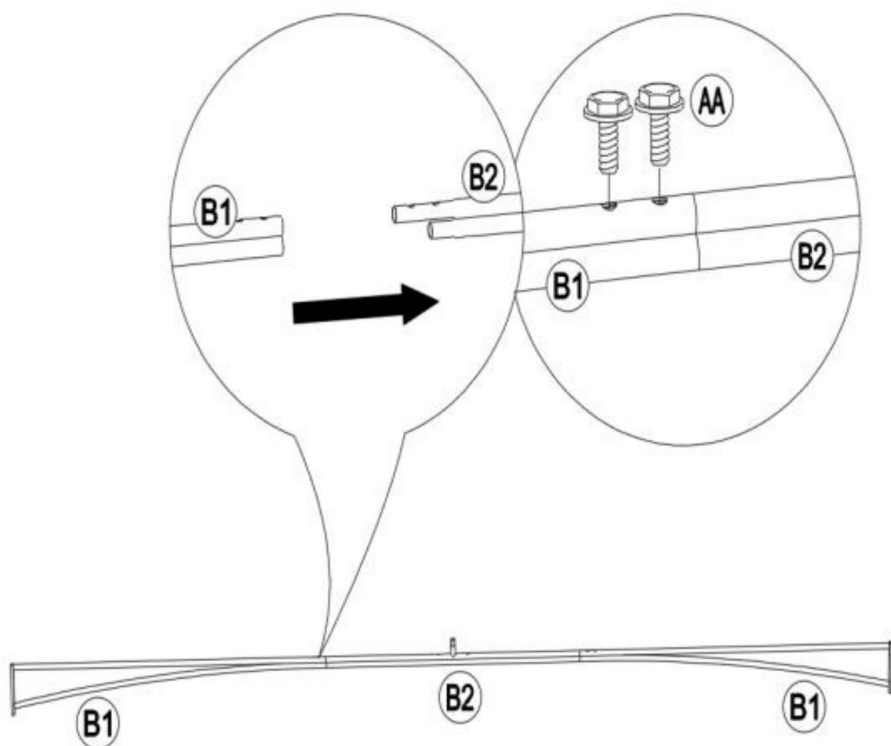
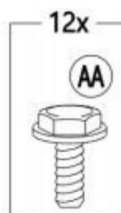
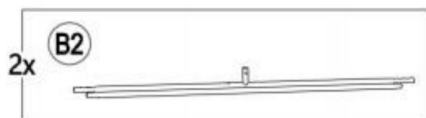
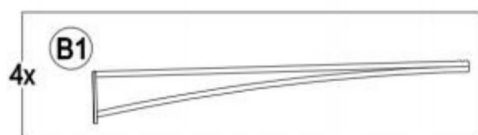

3

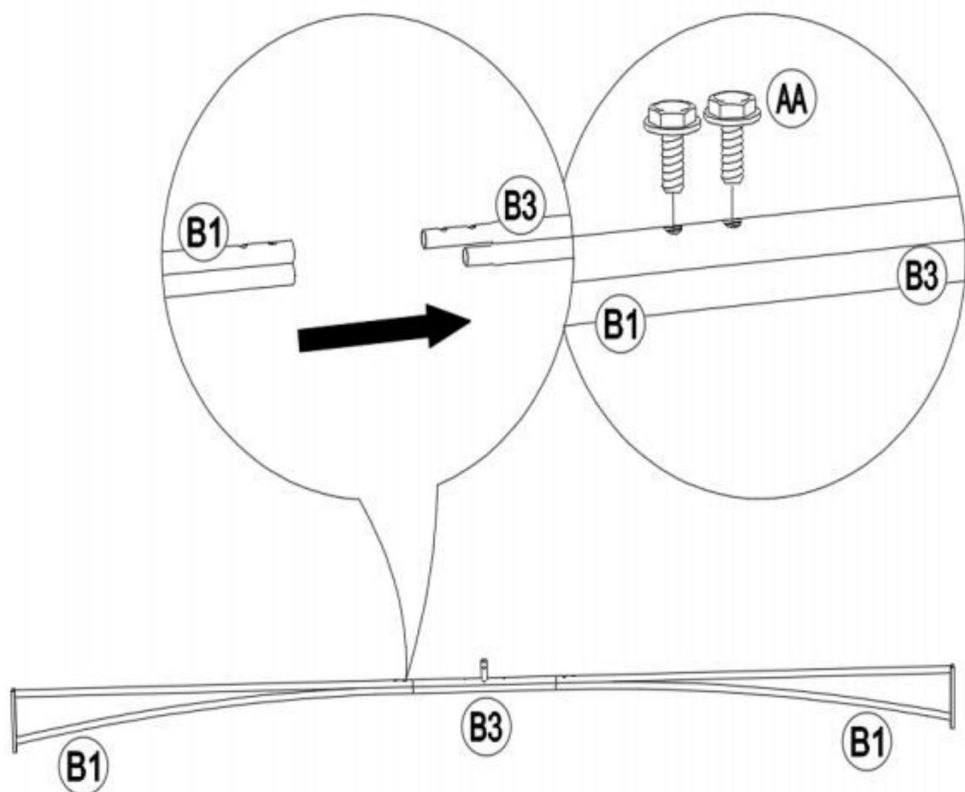
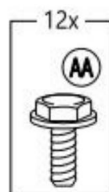
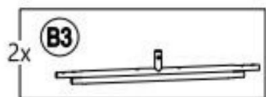
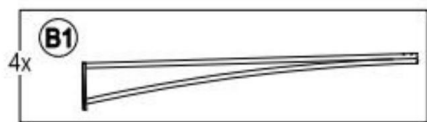

4

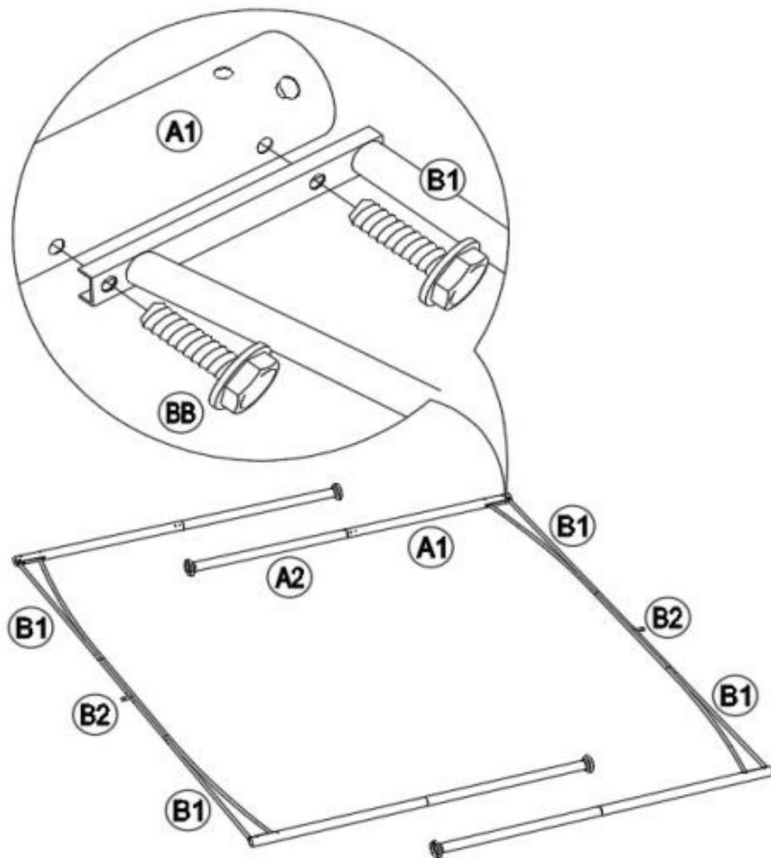
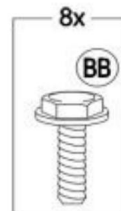
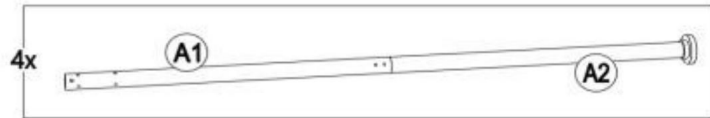
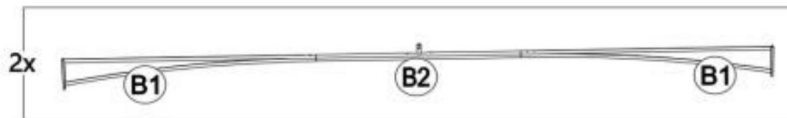

5

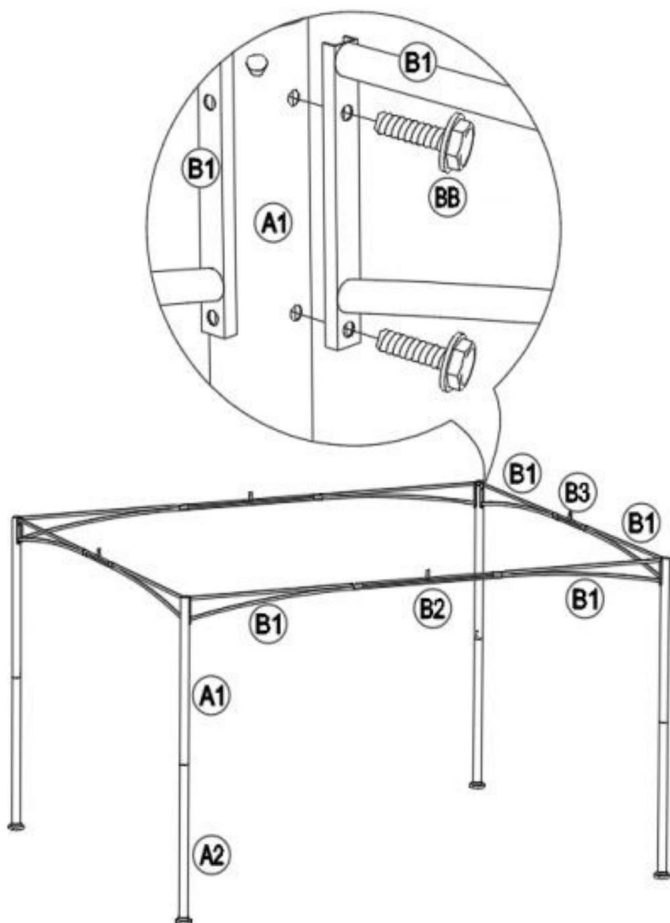
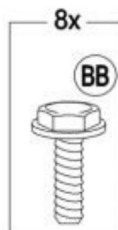
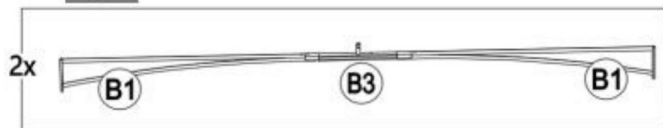

6

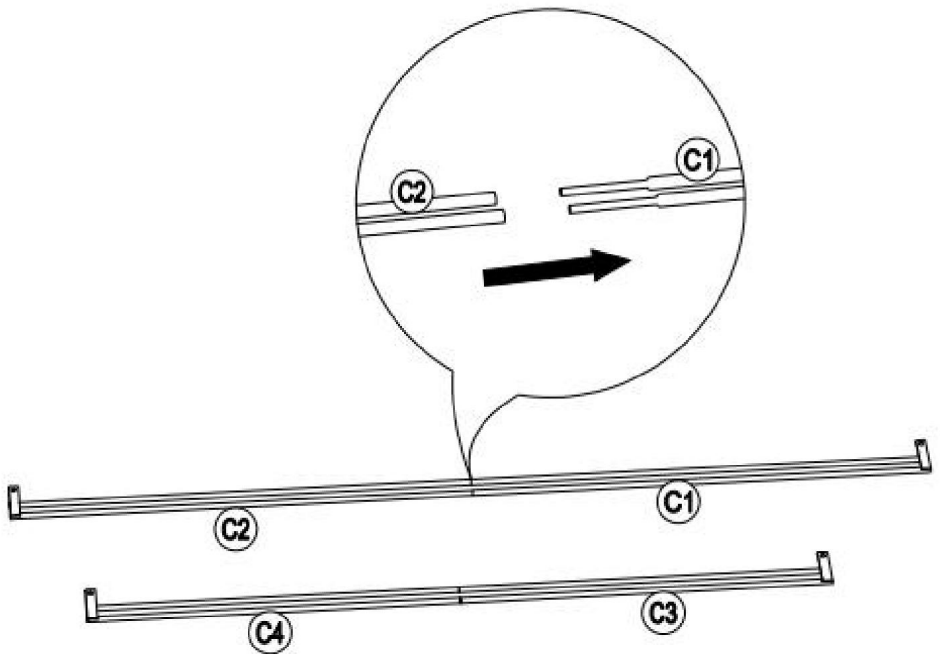
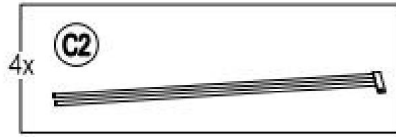
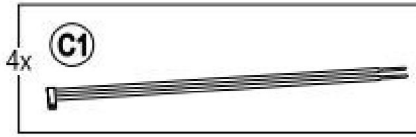

7

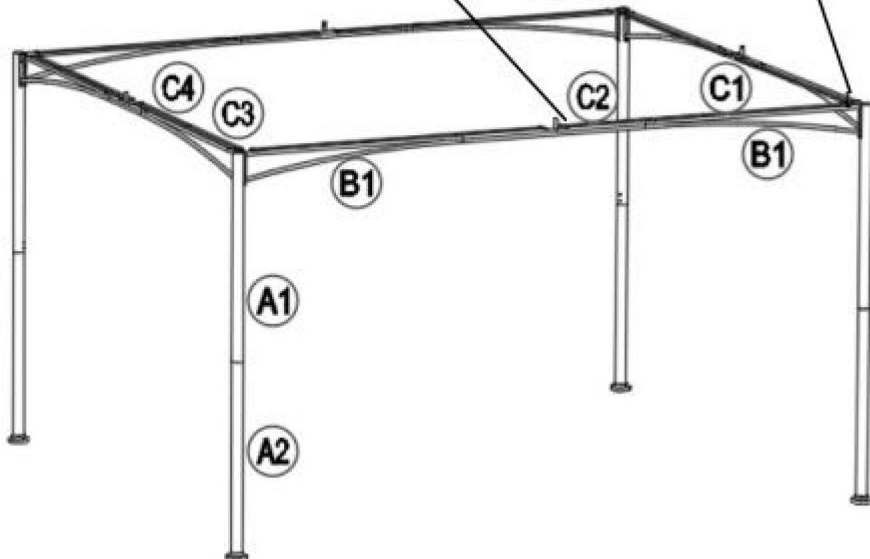
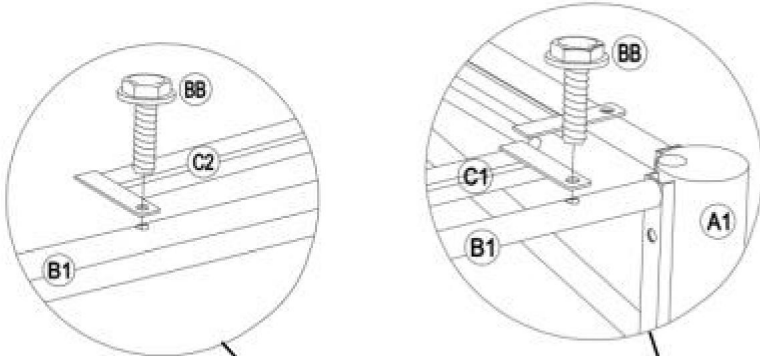
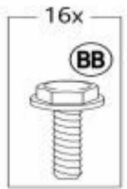

8

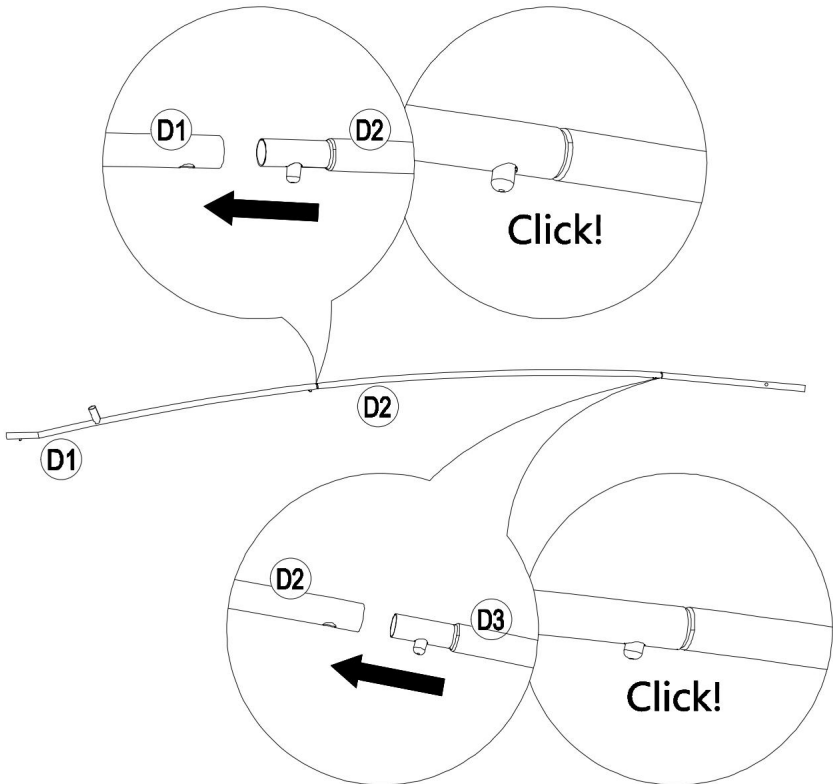
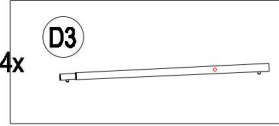
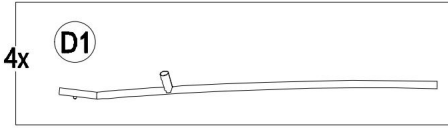

9

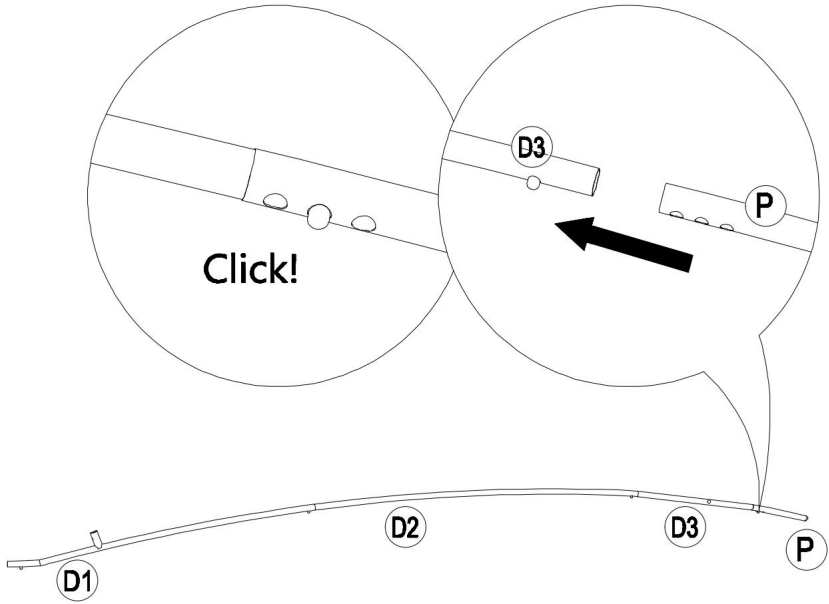
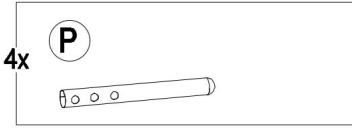

10

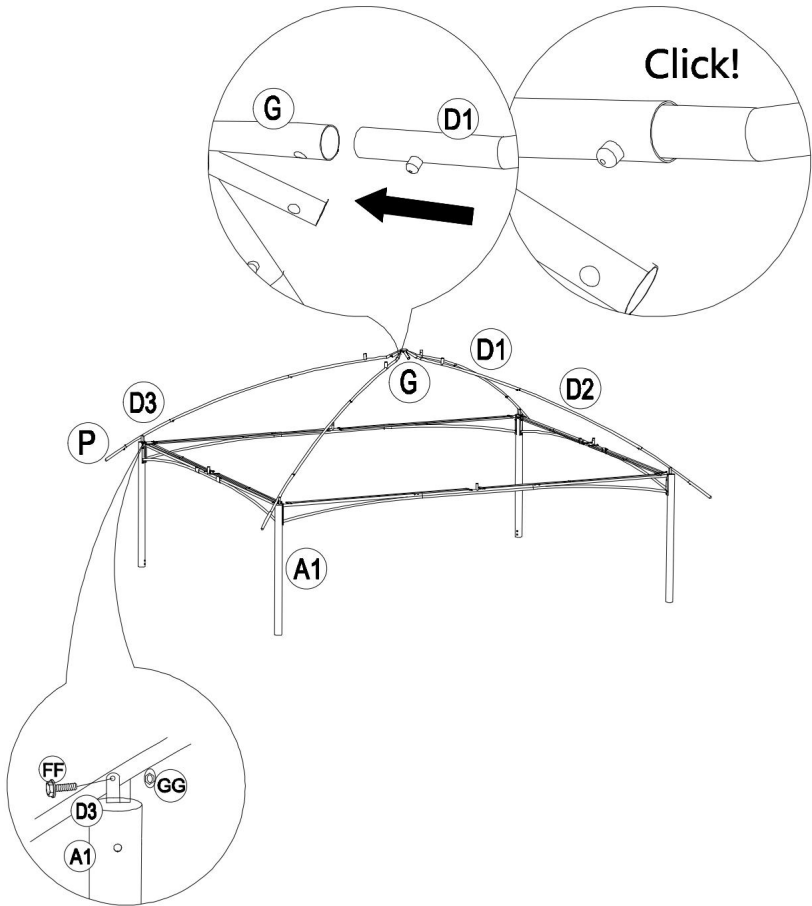
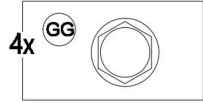
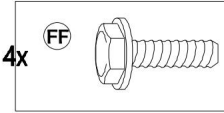
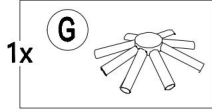
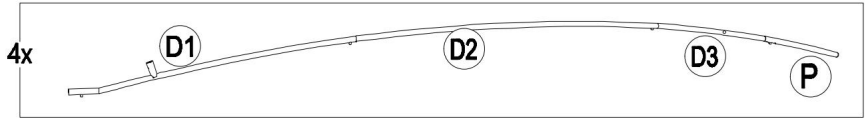

11

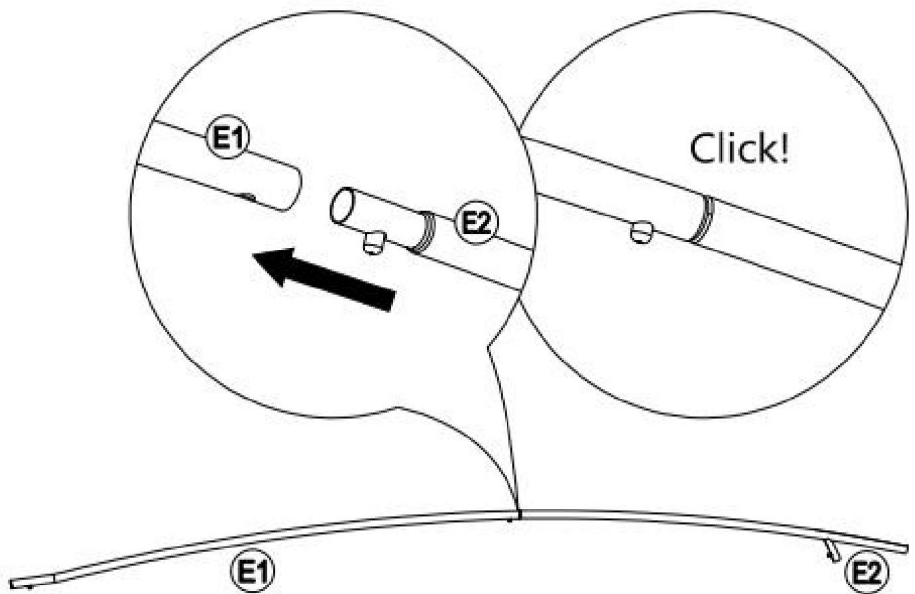

12

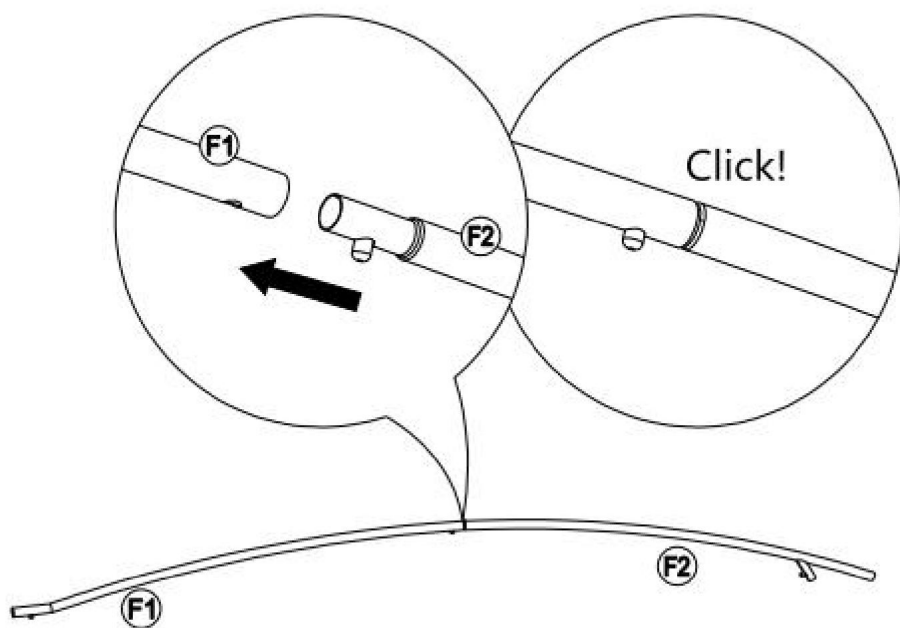
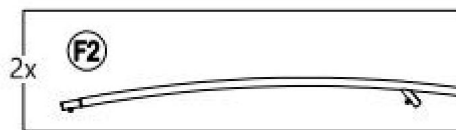
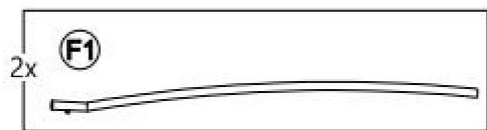

13

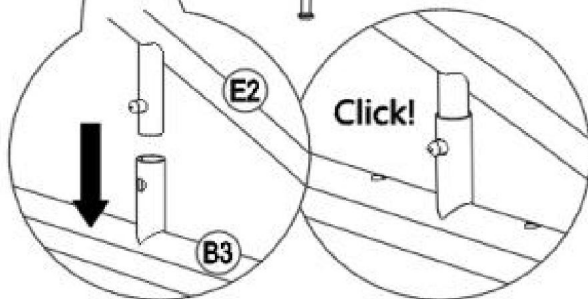
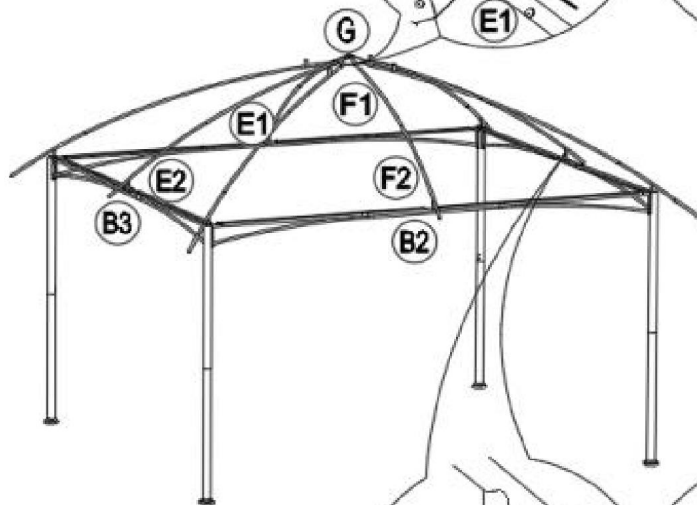
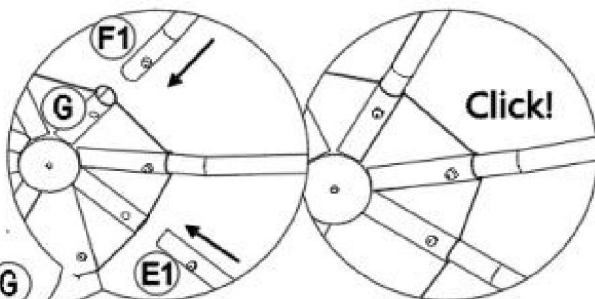
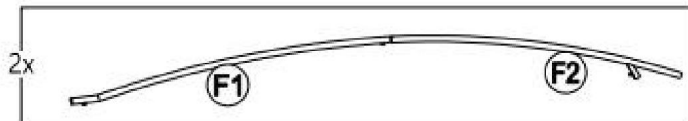
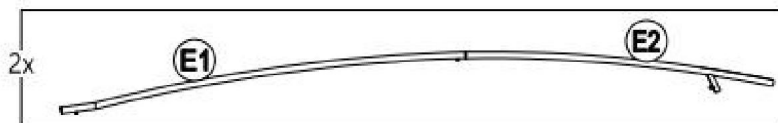

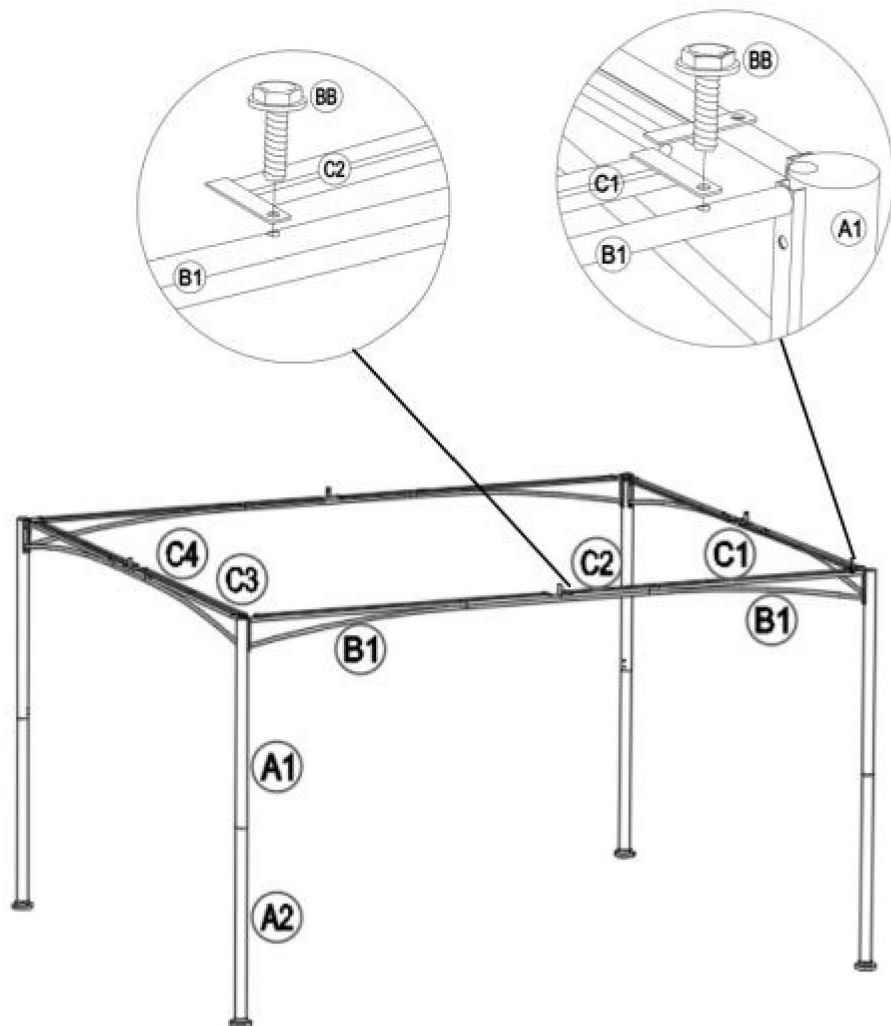

14

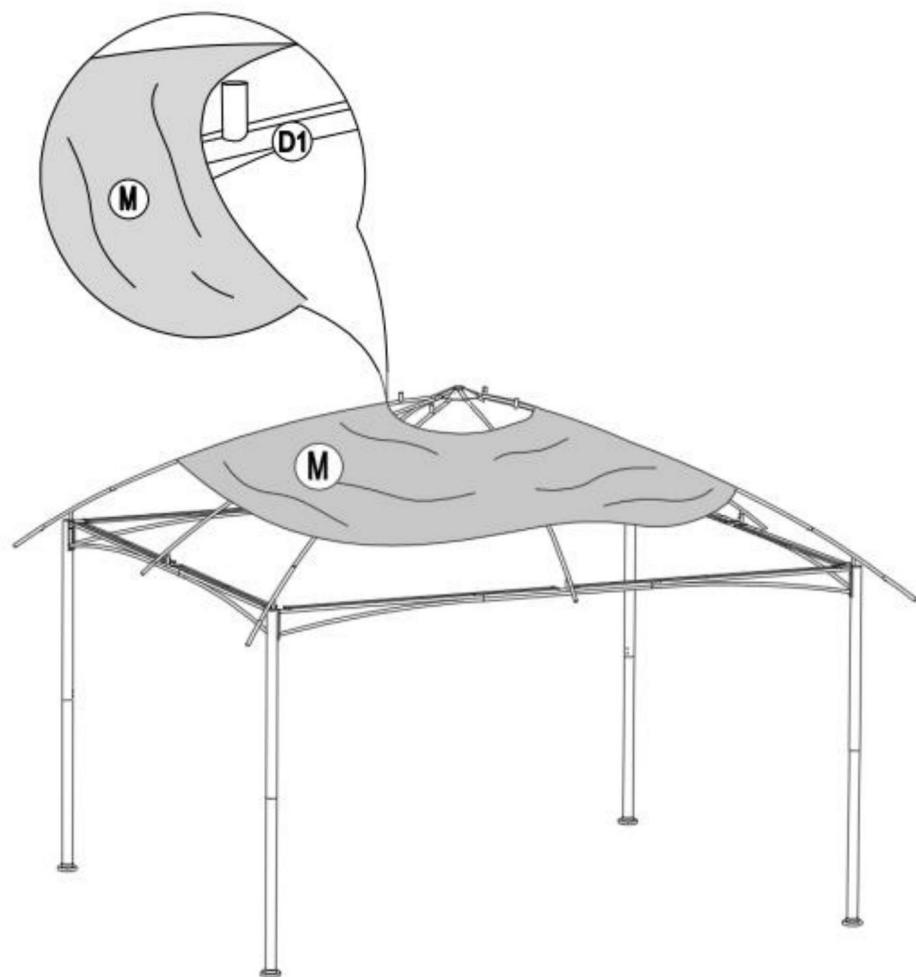
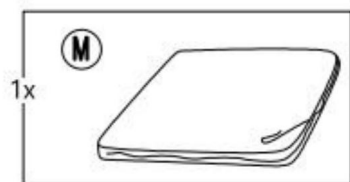

15

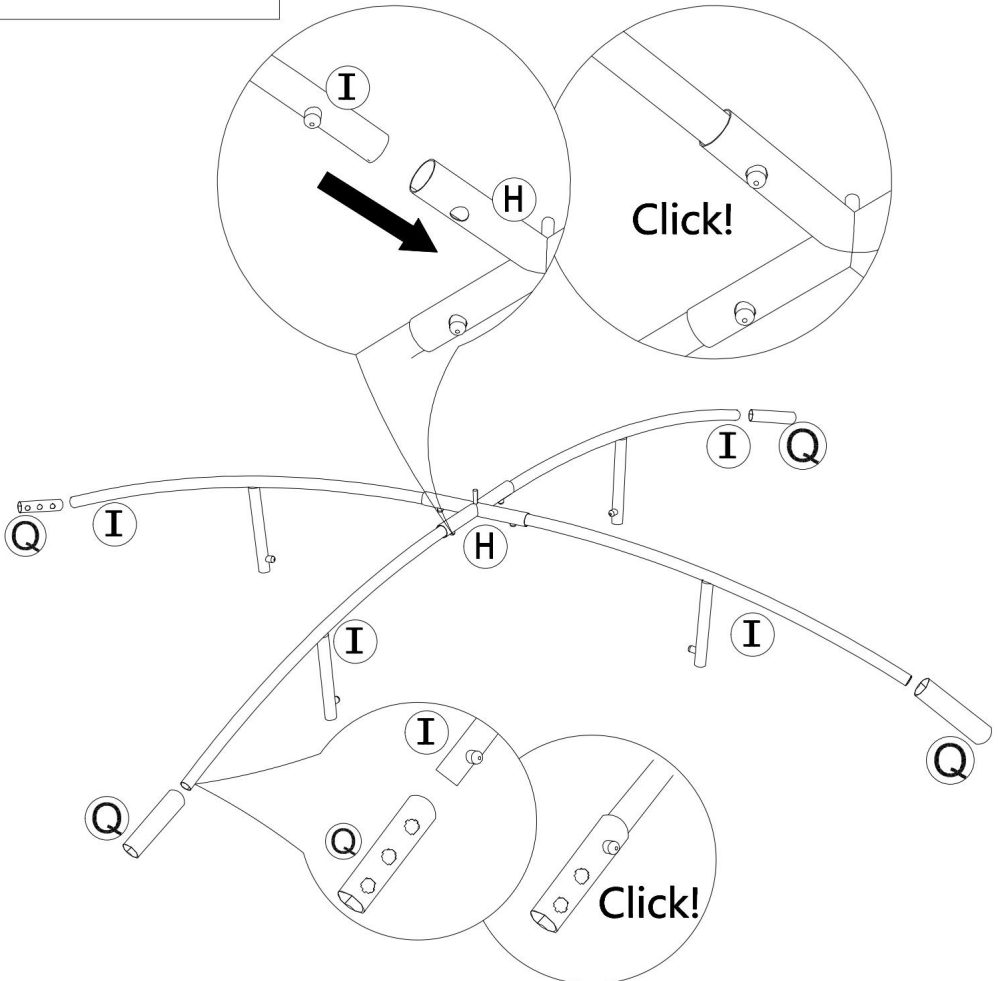
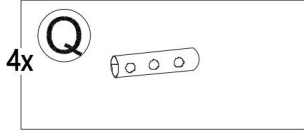
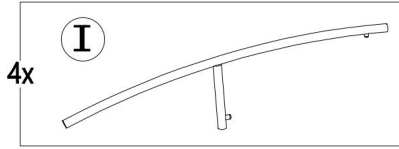
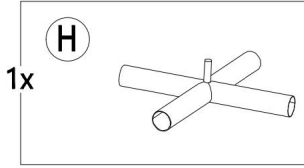

16

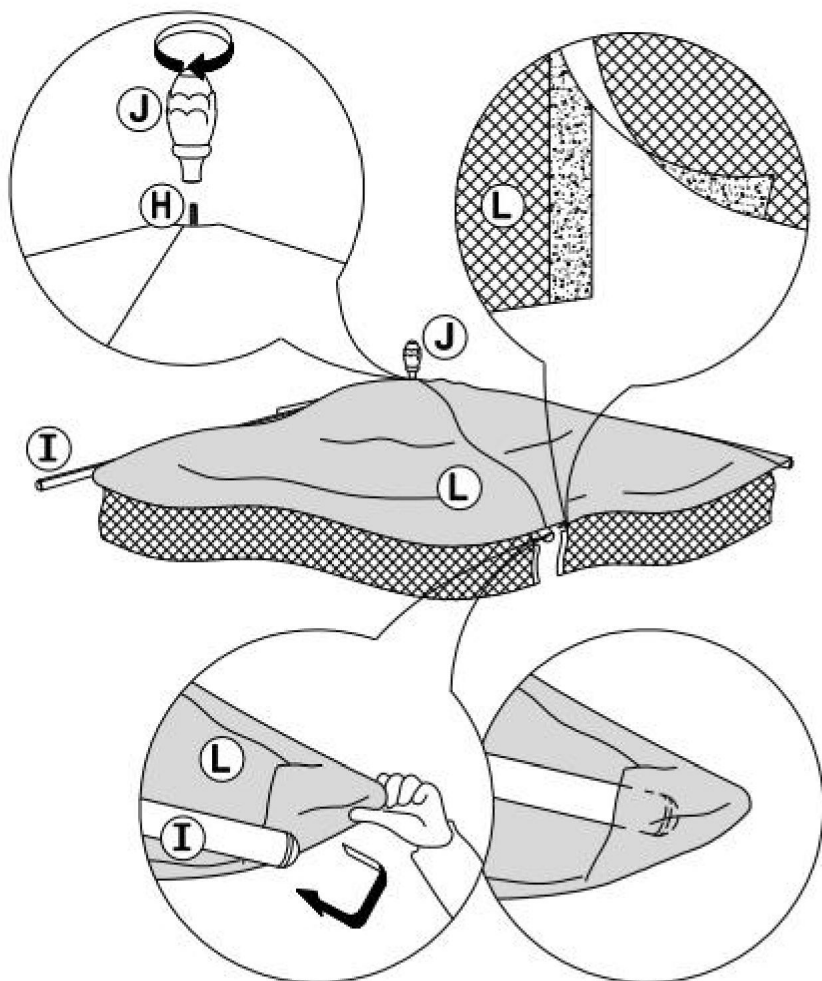
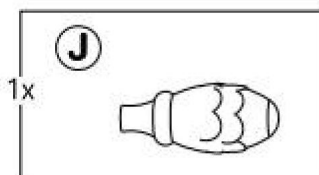
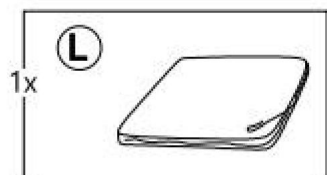

17

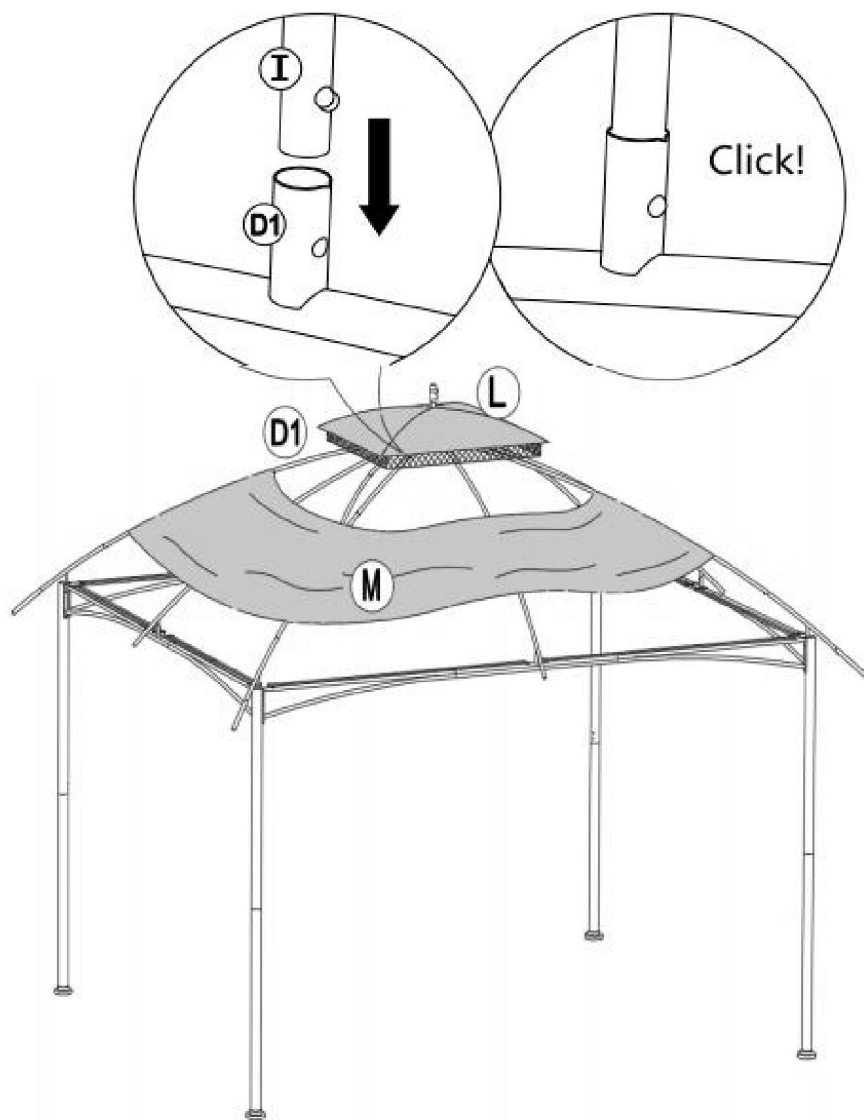

18

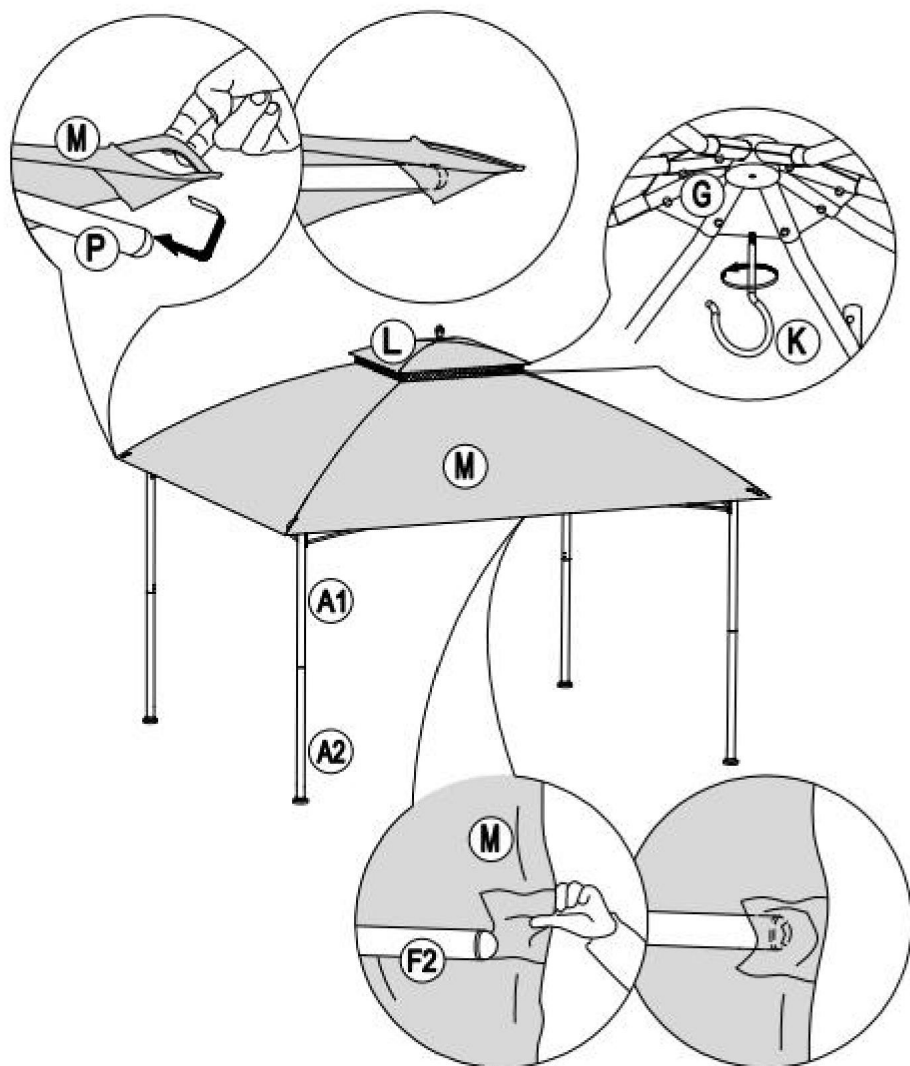
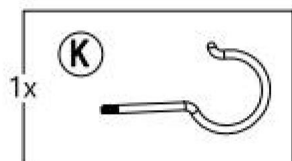

19

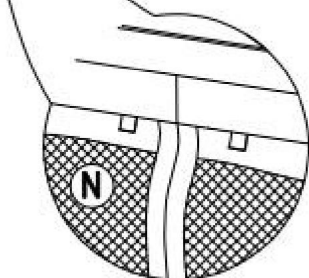
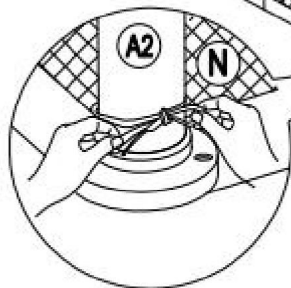
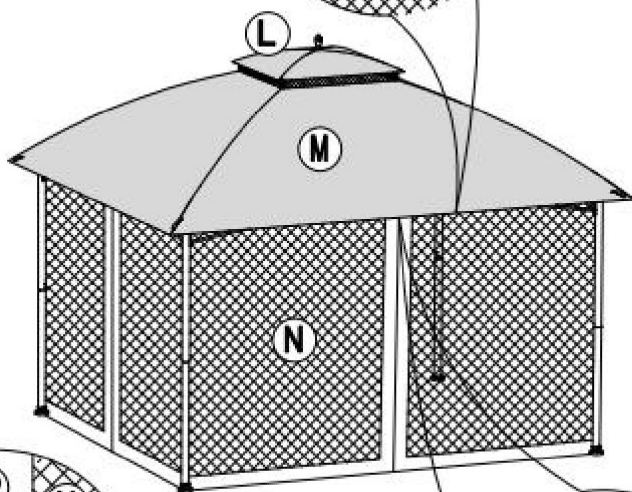
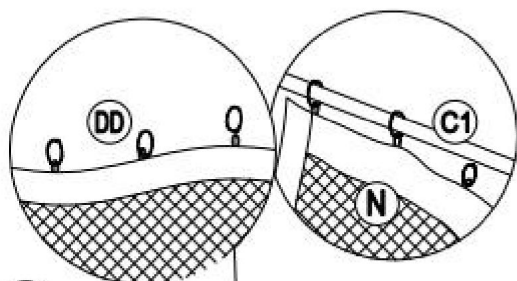
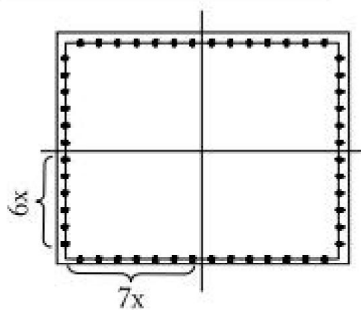
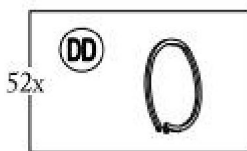
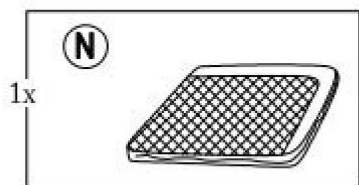

20

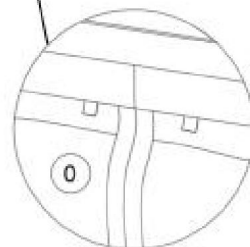
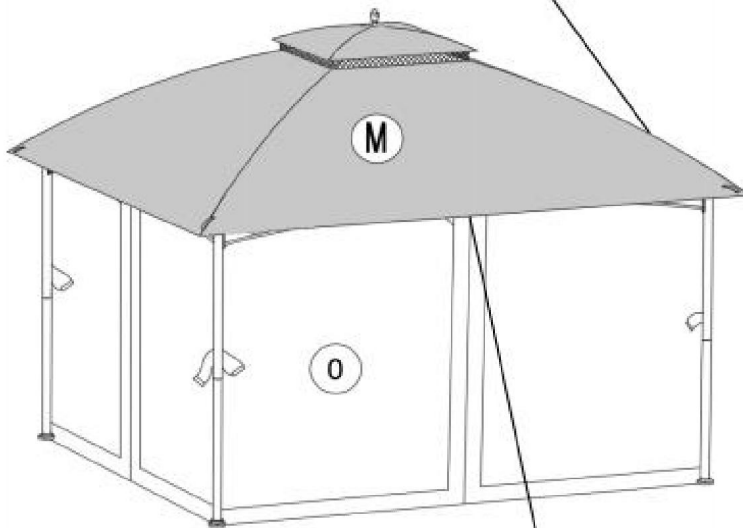
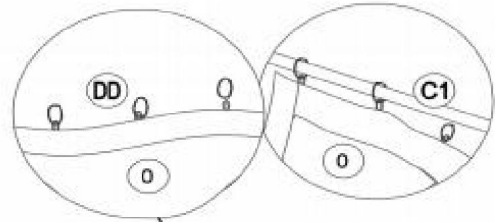
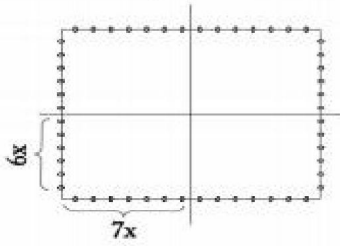
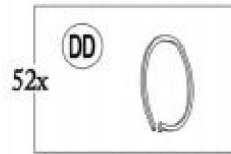
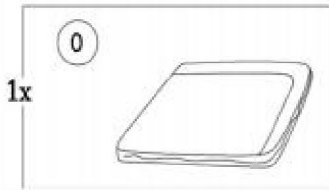

21

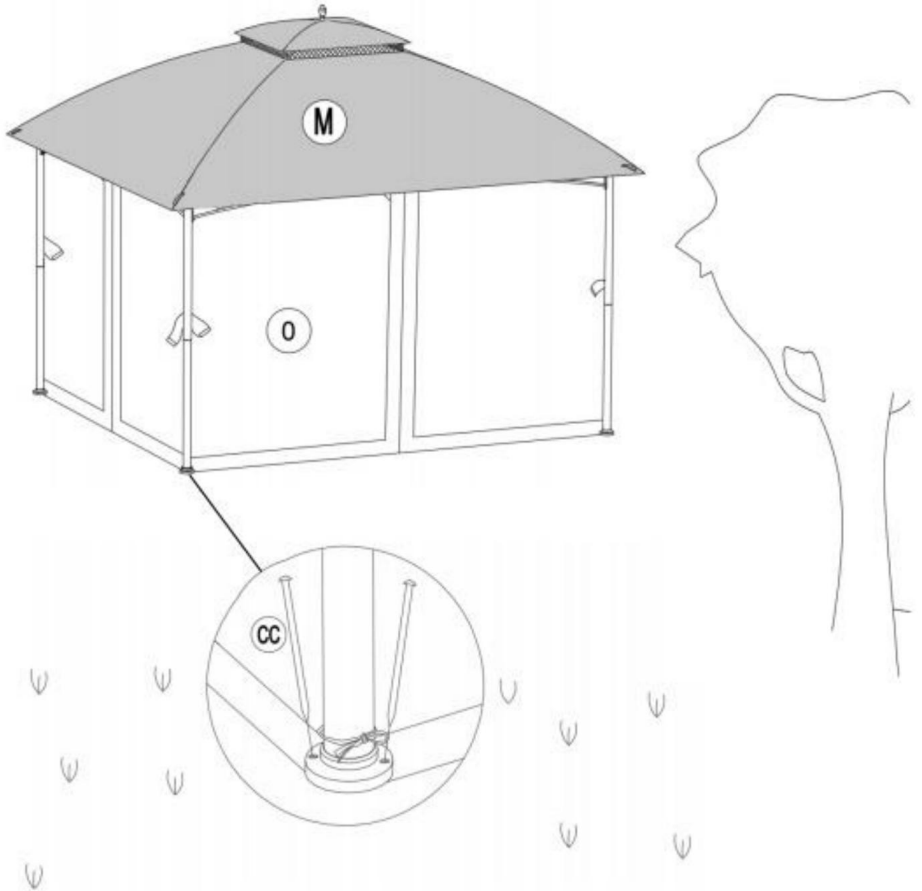

In die USA importiert: Sanven Technology Ltd.
Suite 250, 9166 Anaheim Place, Rancho Cucamonga, CA 91730

VEVOR[®]

TOUGH TOOLS, HALF PRICE

Technischer Support und E-Garantie-Zertifikat

www.vevor.com/support

VEVOR[®]

TOUGH TOOLS, HALF PRICE

Assistance technique et certificat de garantie électronique www.vevor.com/support

INSTRUCTION POUR LES GAZEBO DE TERRASSE

MODÈLE : KD-TY007-1

Nous continuons à nous engager à vous fournir des outils à des prix compétitifs.

« Économisez la moitié », « Moitié prix » ou toute autre expression similaire utilisée par nous ne représente qu'une estimation des économies que vous pourriez réaliser en achetant certains outils chez nous par rapport aux grandes marques et ne couvre pas nécessairement toutes les catégories d'outils que nous proposons.

Nous vous rappelons de bien vouloir vérifier soigneusement lorsque vous passez une commande chez nous si vous économisez réellement la moitié par rapport aux grandes marques

VEVOR[®]

TOUGH TOOLS, HALF PRICE

KIOSQUES DE TERRASSE

KD-TY007-1

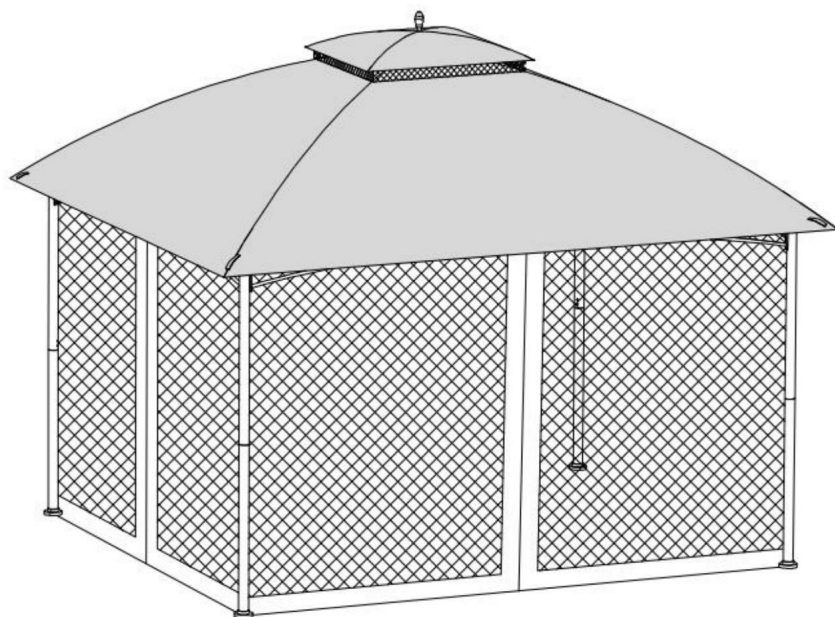

BESOIN D'AIDE? CONTACTEZ-NOUS!

Vous avez des questions sur nos produits ? Vous avez besoin d'assistance technique ? N'hésitez pas à nous contacter :

Assistance technique et certificat de garantie électronique www.vevor.com/support

Il s'agit de la notice d'utilisation d'origine. Veuillez lire attentivement toutes les instructions du manuel avant de l'utiliser. VEVOR se réserve le droit d'interpréter clairement notre manuel d'utilisation. L'apparence du produit dépend du produit que vous avez reçu. Veuillez nous excuser, nous ne vous informerons plus en cas de mise à jour technologique ou logicielle de notre produit.

INSTRUCTIONS DE MONTAGE ET DE SÉCURITÉ

Veillez prêter une attention particulière aux instructions suivantes afin de réduire les risques de blessures, d'accidents ou de dommages au produit lui-même.

IMPORTANT

Veillez suivre TOUTES les instructions de sécurité énumérées ci-dessous.

Veillez retirer le matériel d'emballage avant d'assembler ou d'utiliser le produit.

Veillez vous assurer que toutes les pièces répertoriées sont incluses dans l'emballage et qu'elles sont pas endommagées.

Veillez lire attentivement ces instructions de montage et de sécurité avant d'utiliser l'appareil. tente et conservez-la pour référence ultérieure.

Ce produit ne doit être utilisé que de manière non commerciale.

INFORMATIONS DE SÉCURITÉ

La tente n'a pas été testée pour les charges de vent et de neige, sauf si cela est clairement indiqué sinon. Par conséquent, ces charges ne sont pas couvertes par la garantie. Veuillez regarder la prévisions météorologiques pour pouvoir protéger ou démonter correctement la tente avant des problèmes apparaissent.

Les tentes ne doivent être utilisées que comme hébergement temporaire et doivent être démonté en cas de conditions météorologiques défavorables.

Assurez-vous de garder une distance suffisante par rapport aux habitations ainsi qu'aux lignes de gaz et d'électricité pour éviter d'éventuels dommages. Veuillez vérifier la zone pour les câbles électriques et les conduites de gaz.

Demandez à votre autorité locale de plus amples informations si nécessaire.

Lors de l'utilisation de radiateurs adaptés, gardez une distance minimale de 1,2 m par rapport à la bâche matériel. Feu ouvert ou appareils de chauffage à flamme nue tels que radiateurs de terrasse, parasols les radiateurs, les chauffages à gaz, etc. ne doivent en aucun cas être utilisés à l'intérieur de la tente.

La personne qui s'occupe de la construction de la tente est responsable de sa construction adéquate. le fixer pour assurer sa sécurité. Veuillez vérifier l'ancrage en permanence pour éviter dommages. Un ancrage stable peut prolonger la durée de vie de la tente.

Afin d'assurer votre propre sécurité, assurez-vous de porter des gants. Les pièces métalliques peuvent avoir des bords tranchants et être huileuses à cause de la rouille traitement préventif.

Assurez-vous qu'il n'y a pas de charge de neige permanente. Elle doit être enlevée immédiatement. Il en va de même pour la pluie et d'autres formes de charge.

Attention - veuillez conserver les pièces en plastique et les petites pièces de rechange hors de portée des enfants. un film mince peut adhérer au nez et à la bouche et empêcher la respiration.

MONTAGE ET UTILISATION

Veuillez prévoir un peu plus de temps pour votre première installation de la tente. Les règles à respecter Les étapes à suivre pour monter la tente sont simples. Veuillez utiliser les instructions illustratives pour chaque étape de l'installation.

Les vis reliant les tuyaux aux connecteurs doivent être serrées manuellement, à l'aide d'un clé hexagonale ou un tournevis automatique, réglé au niveau max. 2, pour éviter les dommages matériels porter.

La tente ne doit être montée que par au moins deux adultes. Veuillez garder les enfants à l'écart. loin de la tente pendant son montage pour les protéger.

Assurez-vous de trouver une base plane et uniforme qui convient à la l'assemblage du produit et son utilisation prévue.

Utilisez uniquement les matériaux fournis avec la tente lors de la livraison.

Les bâches ne doivent pas entrer en contact avec des objets à bords tranchants.

La tente peut être utilisée lorsque les températures sont proches de zéro. Cependant, avant de telles températures, utiliser, le matériau de la bâche doit être stocké à une température d'au moins 10 . S'il vous plaît assurez-vous que la bâche ne se casse pas une fois pliée.

Chaque pays a des réglementations différentes concernant les structures mobiles (tentes) et structures immobiles. Veuillez demander à vos autorités locales si une autorisation doit être obtenu pour monter la tente. Dans certains pays, cela dépend de la taille de la tente.

INSTRUCTIONS D'ENTRETIEN ET DE STOCKAGE

Tout type de dommage dû à des actes de la nature (dommages causés par les intempéries) n'est pas couvert.

La tente peut être utilisée lorsque les températures sont proches de zéro. Cependant, avant de telles températures, utiliser, le matériau de la bâche doit être stocké à une température d'au moins 10 . S'il vous plaît assurez-vous que la bâche ne se casse pas une fois pliée.

Les vents forts peuvent endommager le produit. Veuillez ne pas laisser le gazebo laissé sans surveillance pendant une longue période.

L'exposition au soleil peut entraîner une décoloration de la bâche. Cela n'a aucun effet Cela peut avoir un impact sur la facilité d'utilisation du foyer et n'est pas considéré comme un défaut du produit.

Des pluies fortes ou importantes peuvent entraîner l'accumulation de poches d'eau sur le toit. Ces poches doivent être retirées dès que possible.

Veuillez ne pas utiliser de produits chimiques agressifs pour nettoyer le matériau de la bâche. Le meilleur L'agent nettoyant est de l'eau avec une réaction légèrement alcaline.

N'apportez aucune modification à la structure métallique de la tente, par exemple par exemple, la connexion et/ou le soudage de charges supplémentaires, la réalisation de rainures et/ou toute autre déformations.

Veuillez retirer la bâche si le produit n'est pas utilisé pour éviter tout dommage.

Nous vous conseillons de démonter le pavillon en cas de mauvaises conditions météorologiques et saison d'hiver.

La tente/bâche ne doit être pliée, emballée et stockée que lorsqu'elle est complètement sèche. Veuillez ne pas placer aucun autre objet sur la tente/bâche lorsqu'elle est rangée.

CARACTÉRISTIQUES

Model	KD-TY007-1
Product Size	2970×3920×3530mm
Color	Beige/Brown/Black

OUTILS

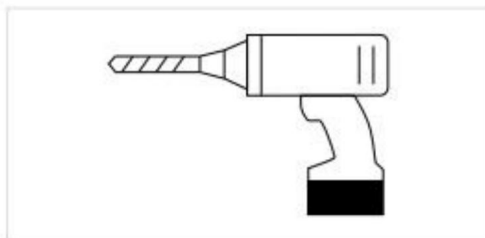





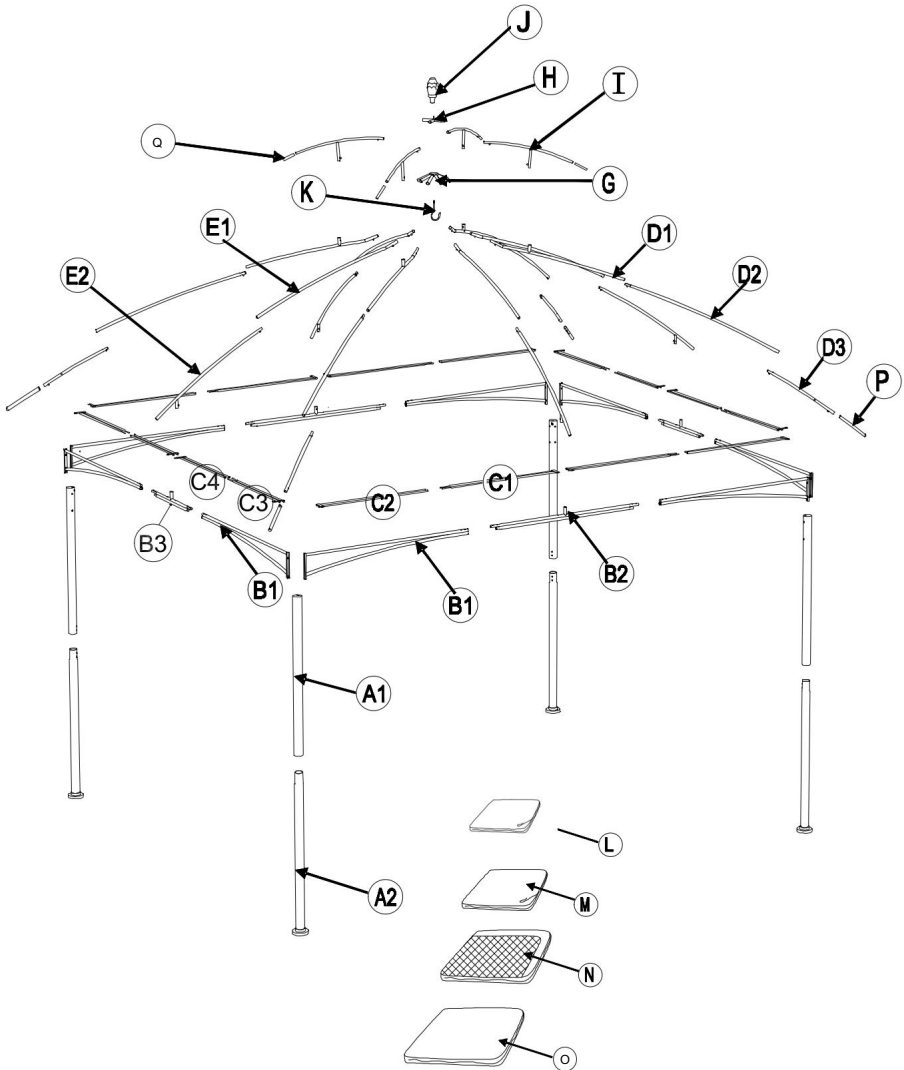
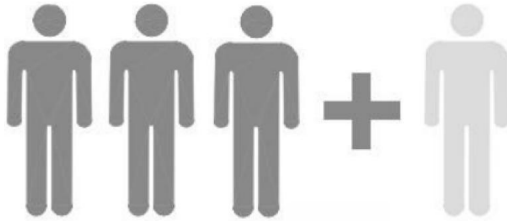



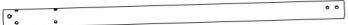

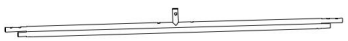
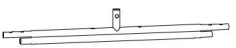













IMPORTANT





People needed for installation work

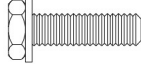
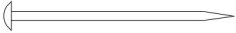

Parts List

Label	Qty	Part Image
A1	4	
A2	4	
B1	8	
B2	2	
B3	2	
C1	4	
C2	4	
C3	4	
C4	4	
D1	4	
D2	4	
D3	4	
E1	2	
E2	2	
F1	2	
F2	2	
G	1	
H	1	

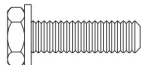
Parts list		
Label	Qty	Parts Image
I	4	
J	1	
K	1	
L	1	
M	1	
N	1	
P	4	
O	1	
Q	4	

Parts list				
Label	Description	Qty	Add	Parts Image
AA	M5*15	24	2	
BB	M6*20	40	2	
CC	Φ8*180	8	0	
DD	/	104	3	
EE	M5/M6	1	0	
FF	M6*35	4	1	
GG	M6	4	1	

1

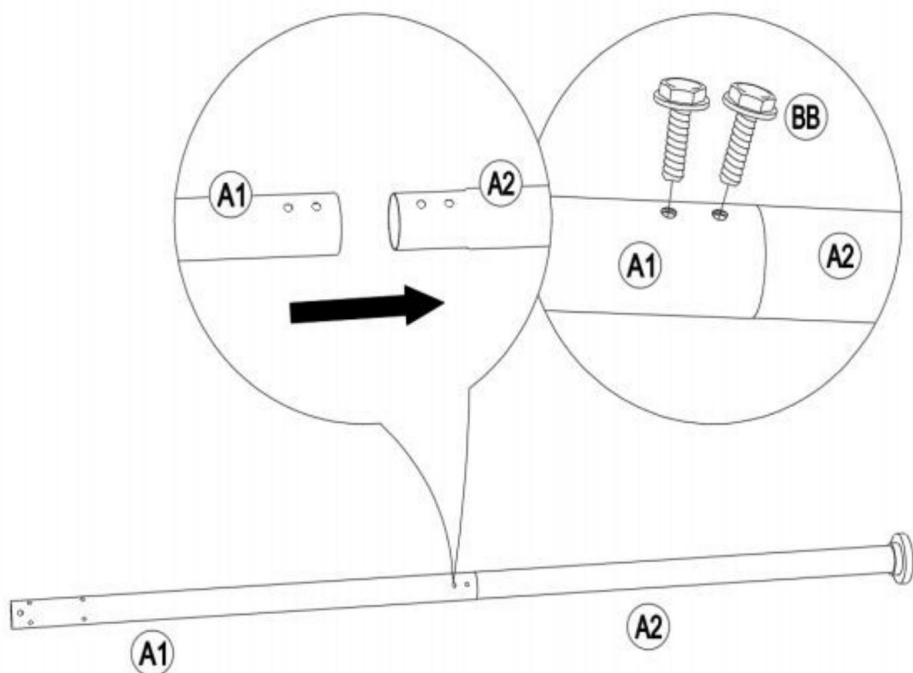
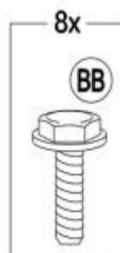
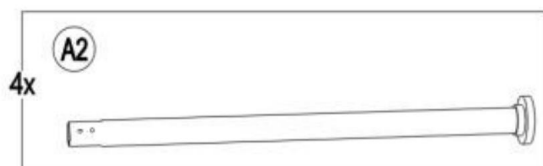

2

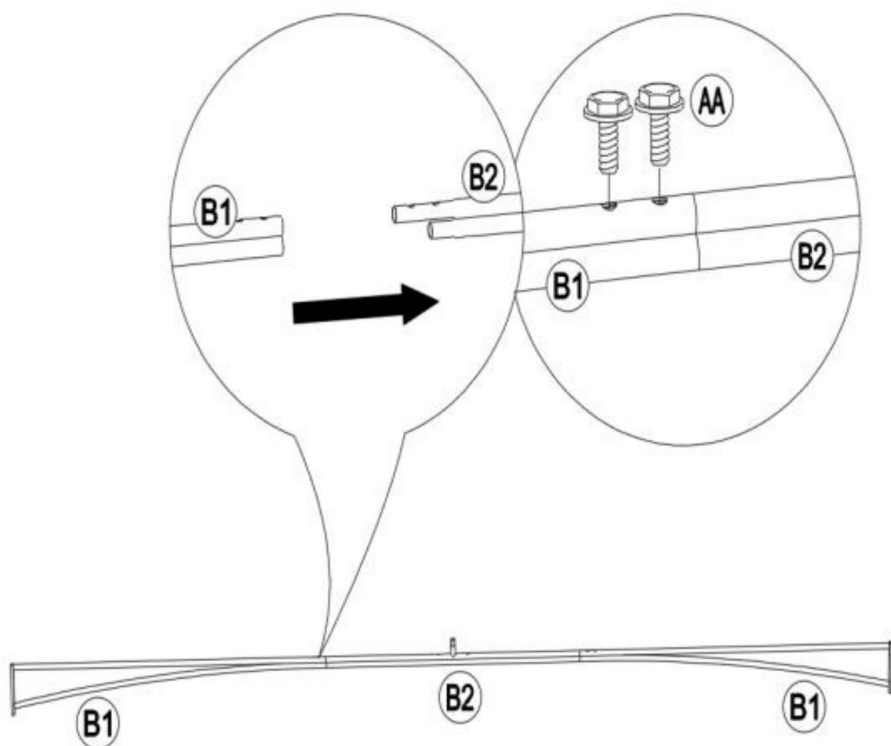
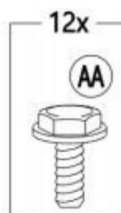
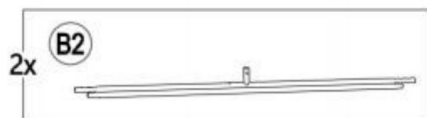
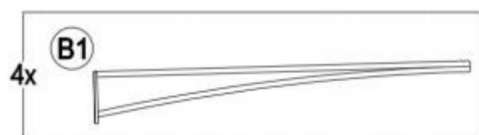

3

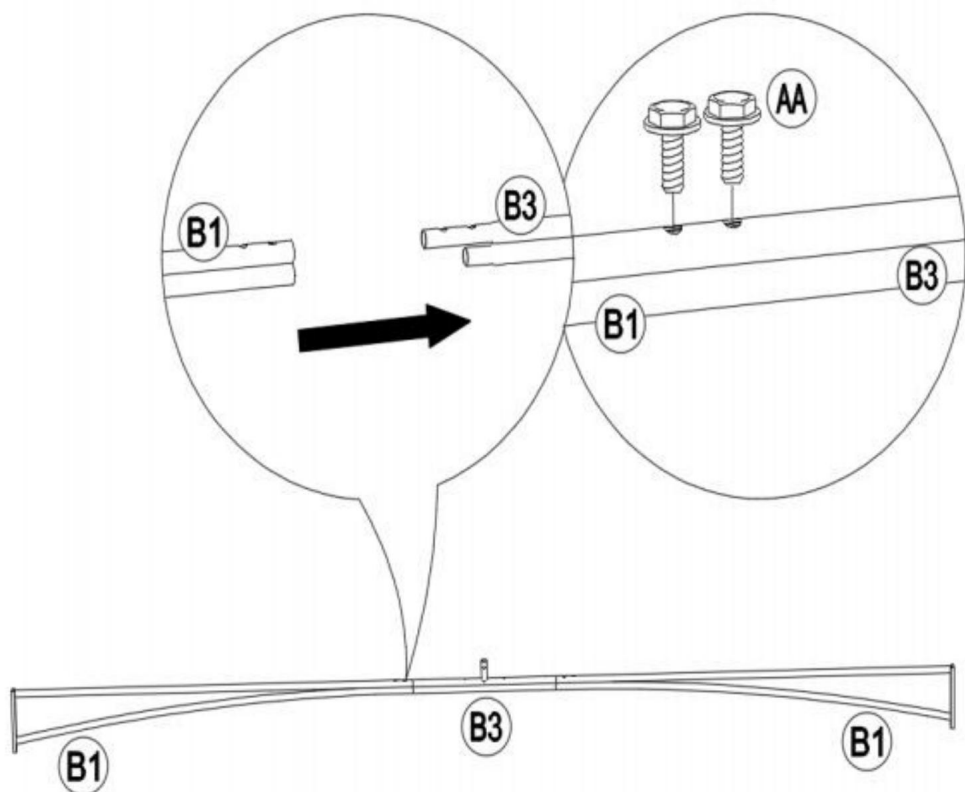
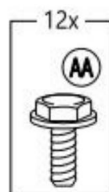
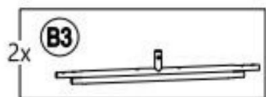
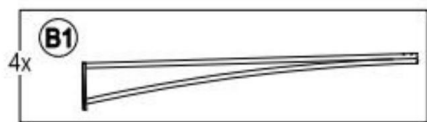

4

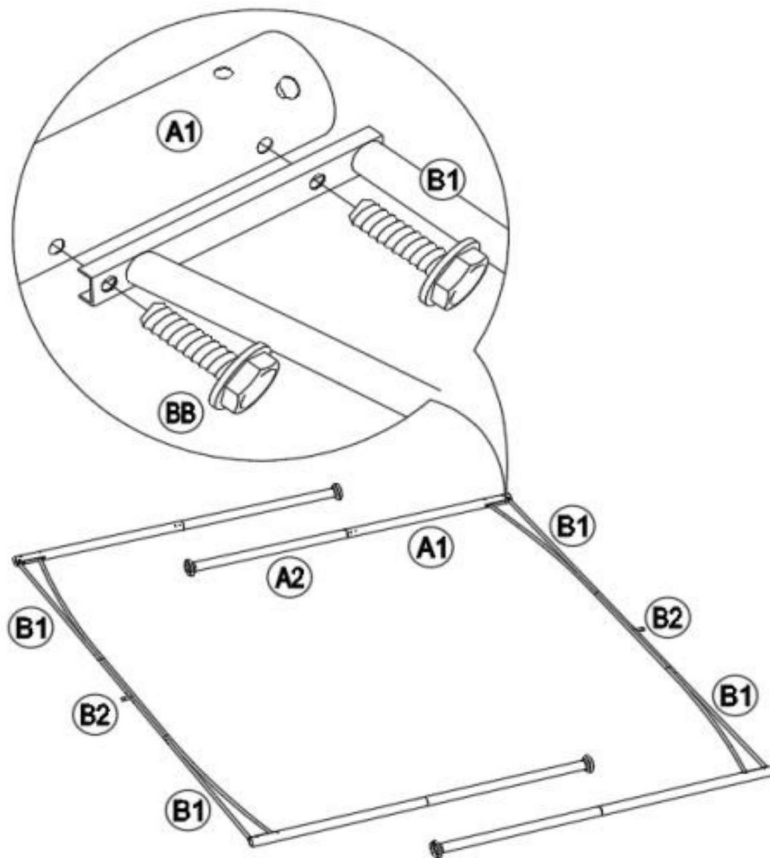
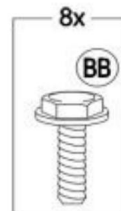
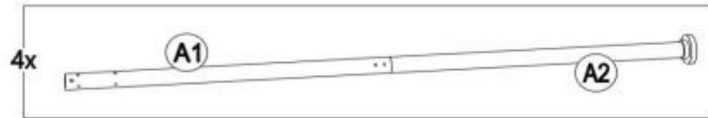
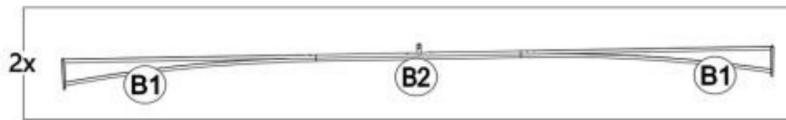

5

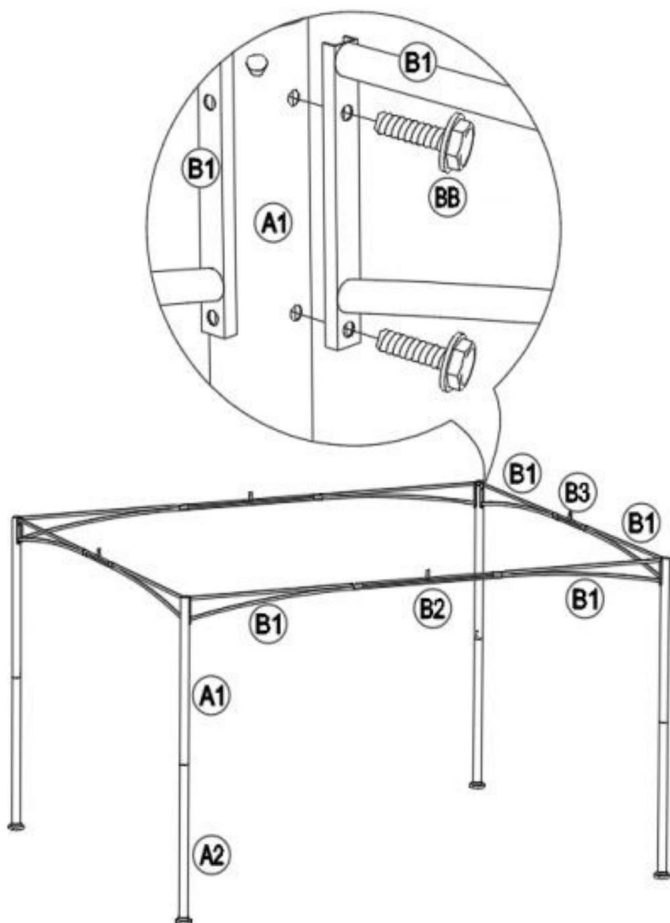
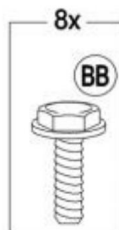
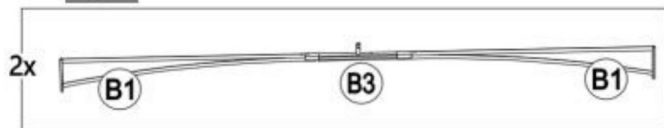

6

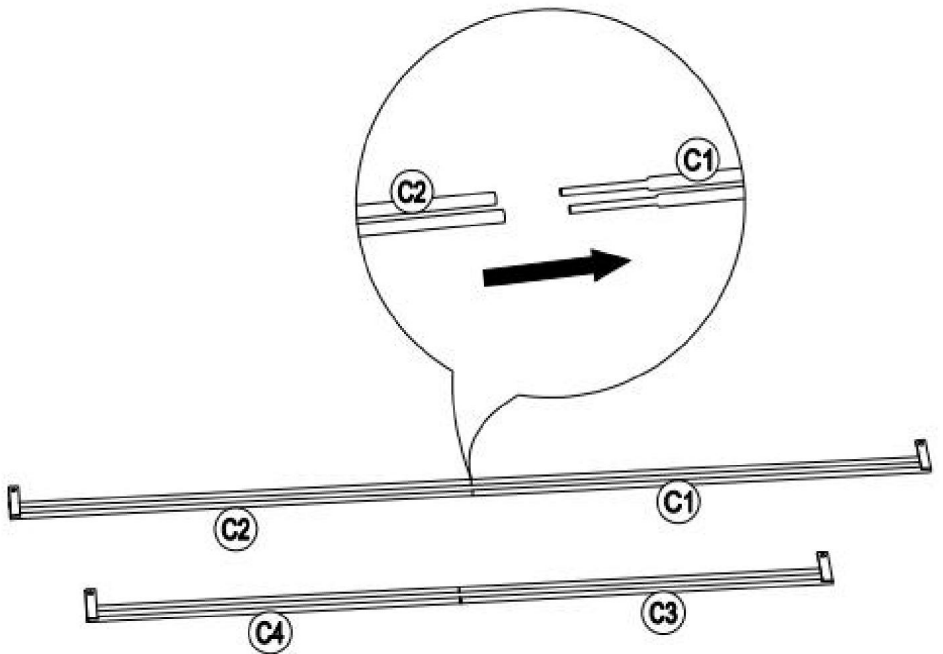
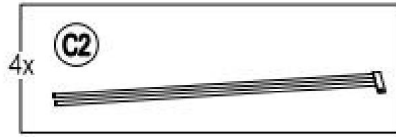
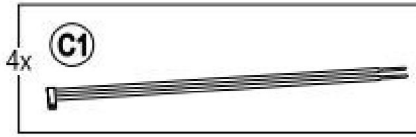

7

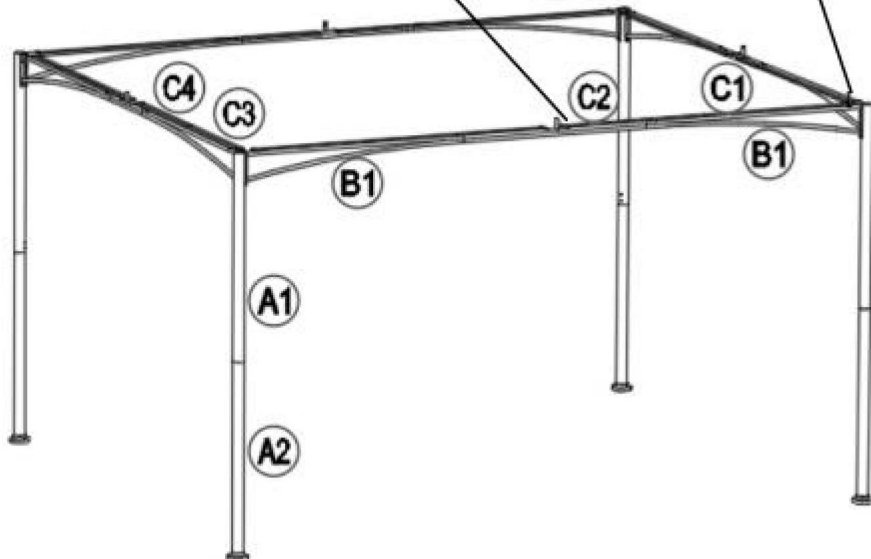
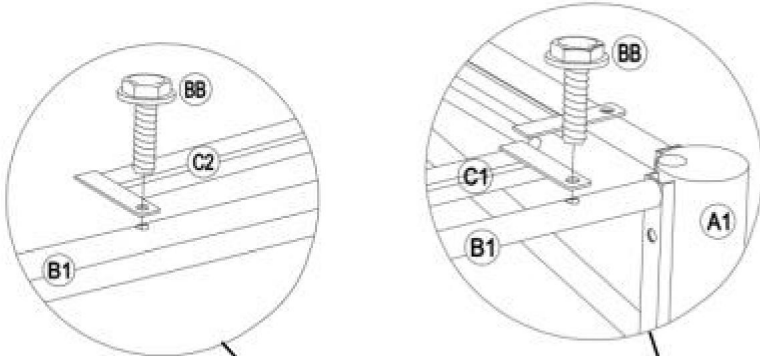
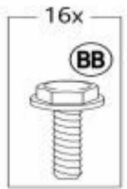

8

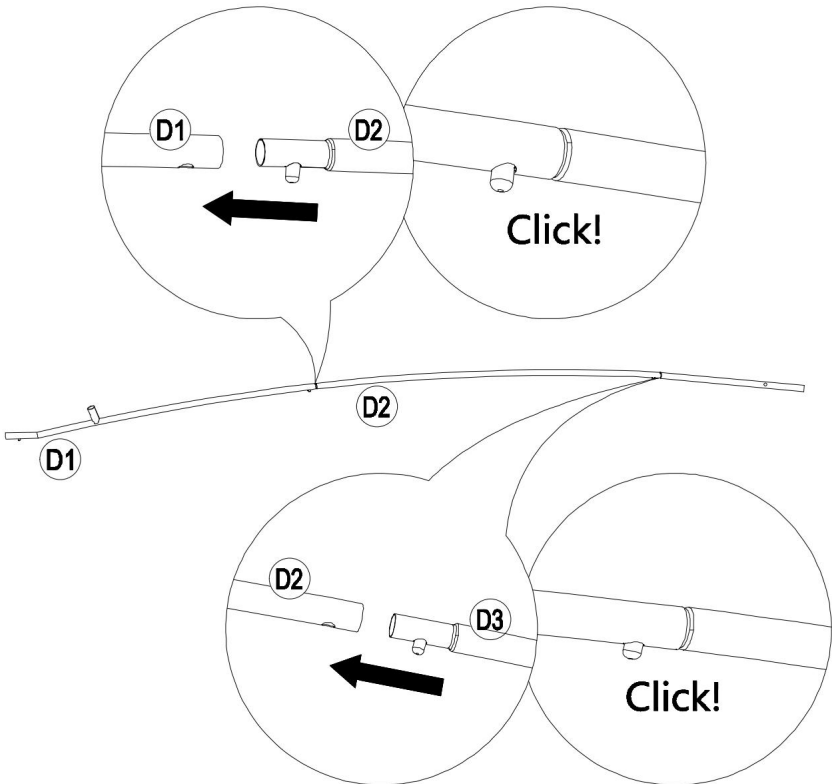
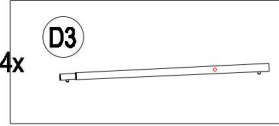
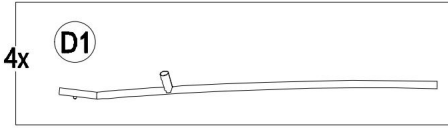

9

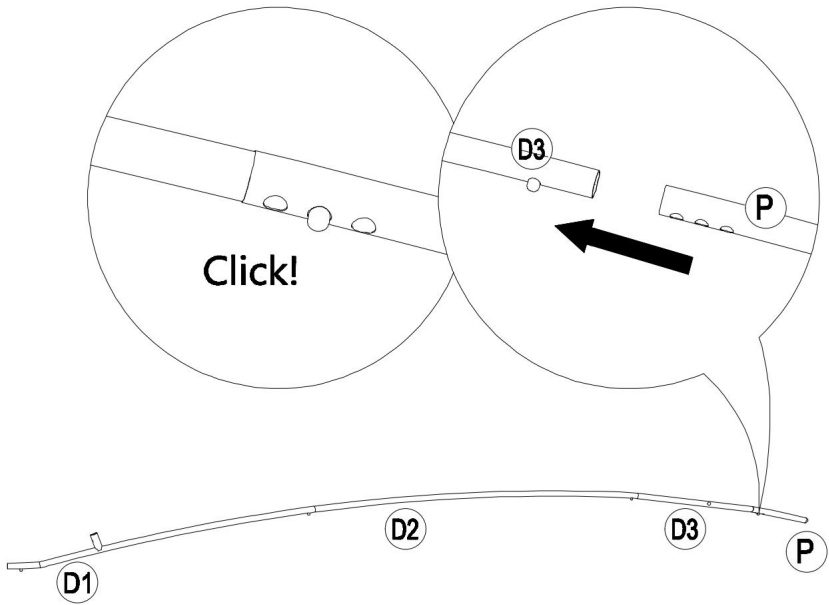
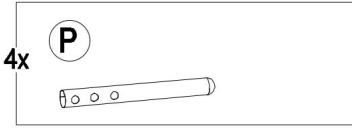

10

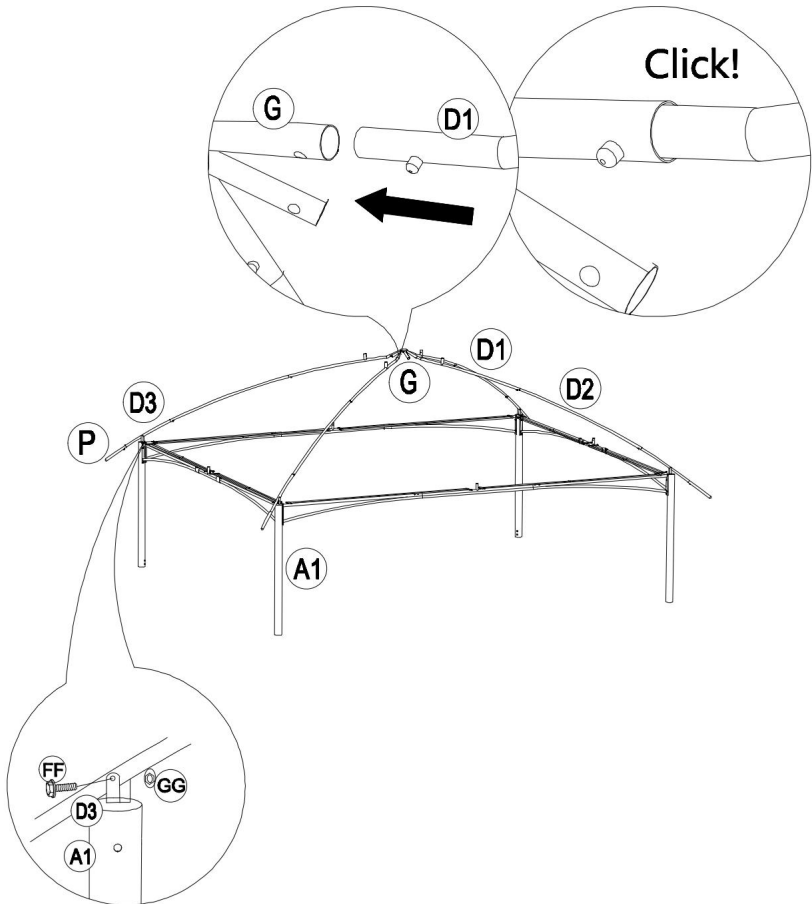
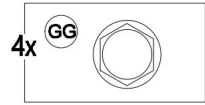
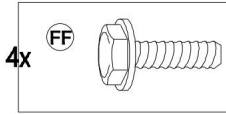
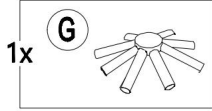
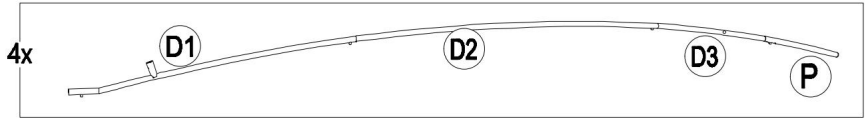

11

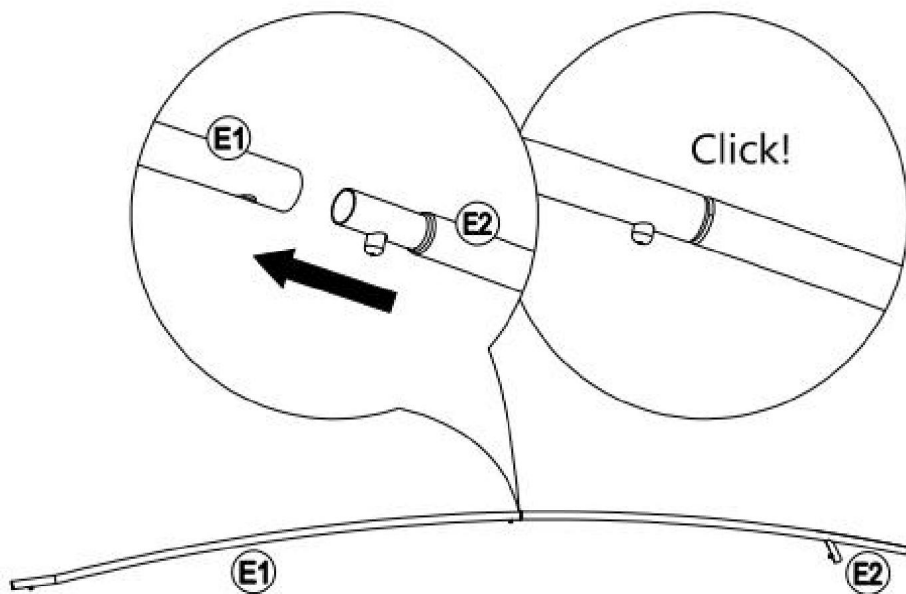

12

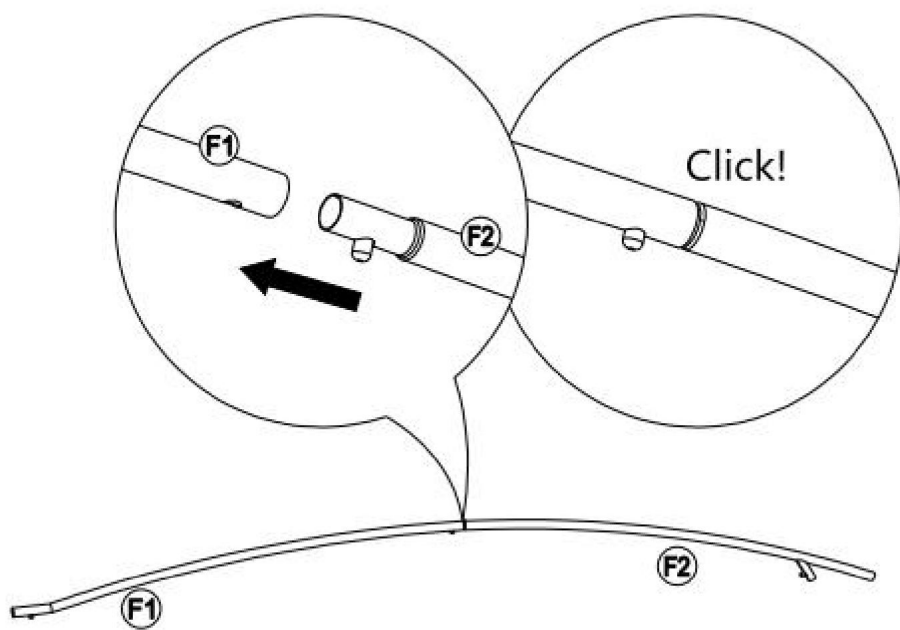
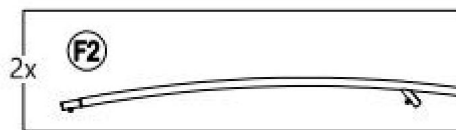
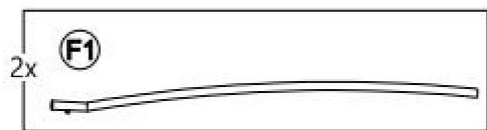

13

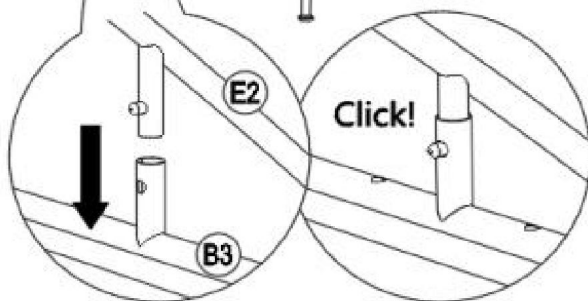
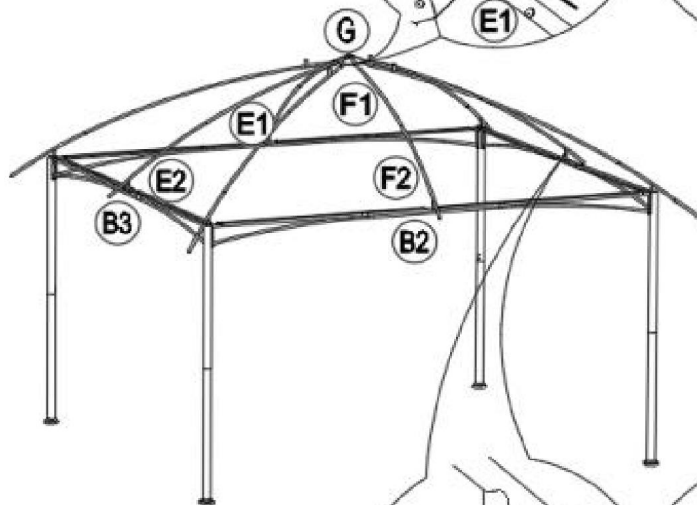
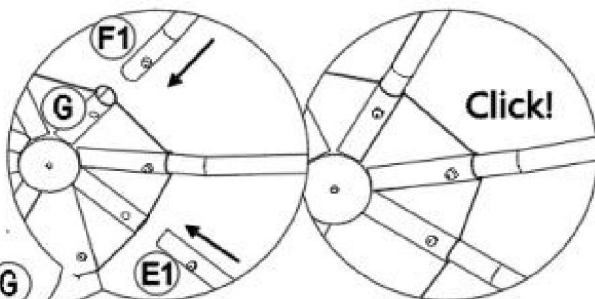
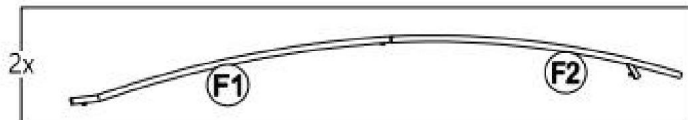
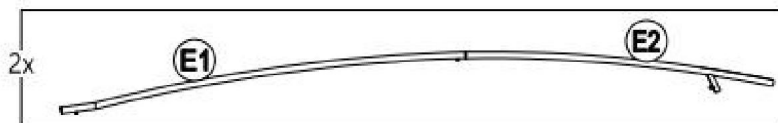

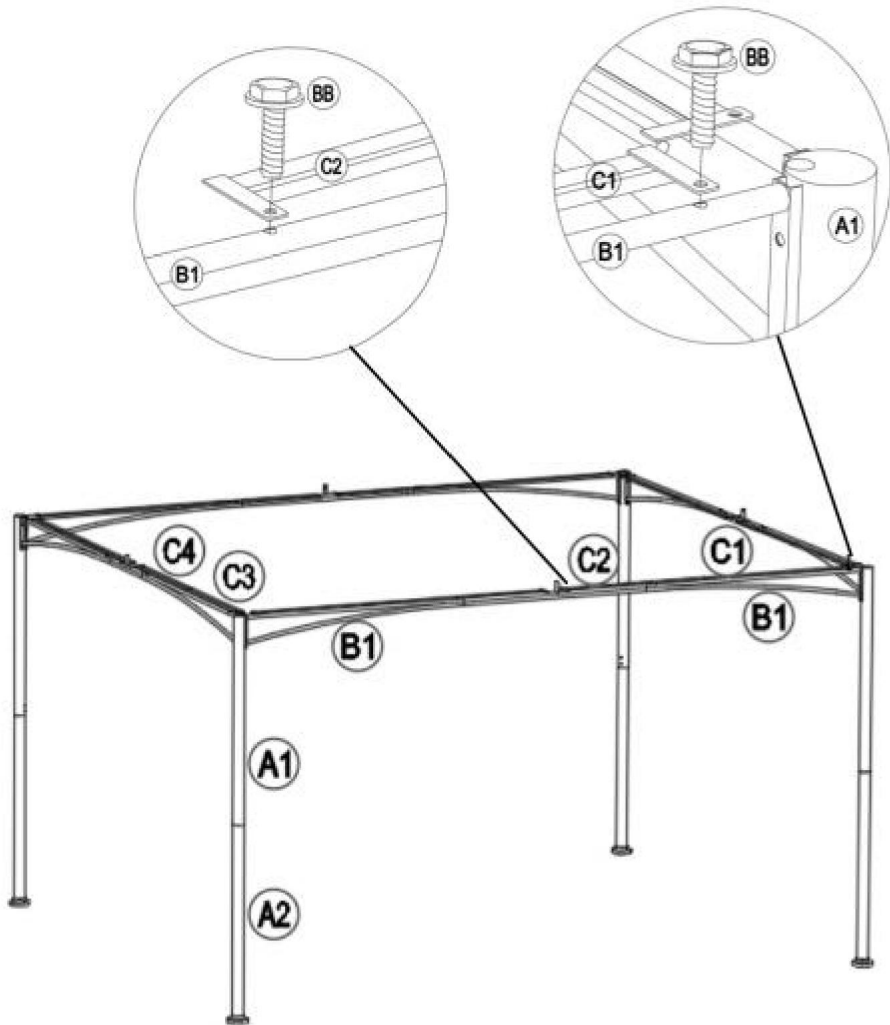

14

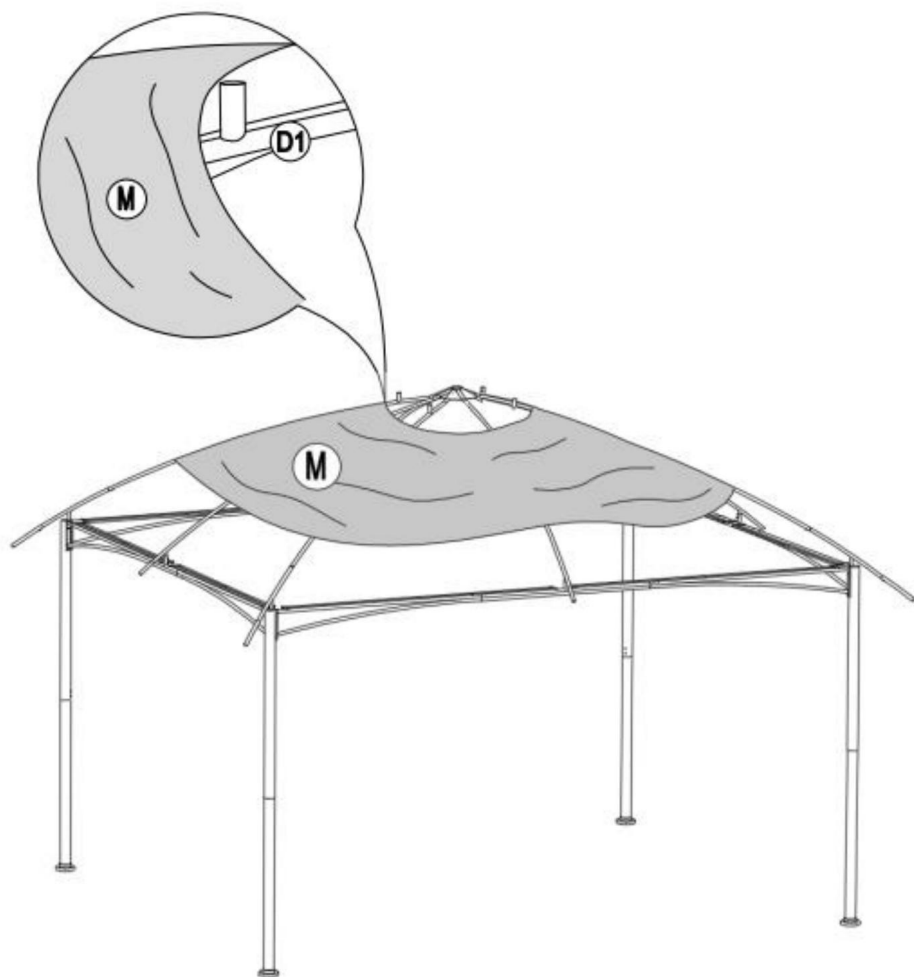
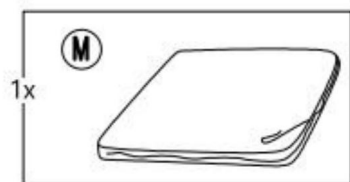

15

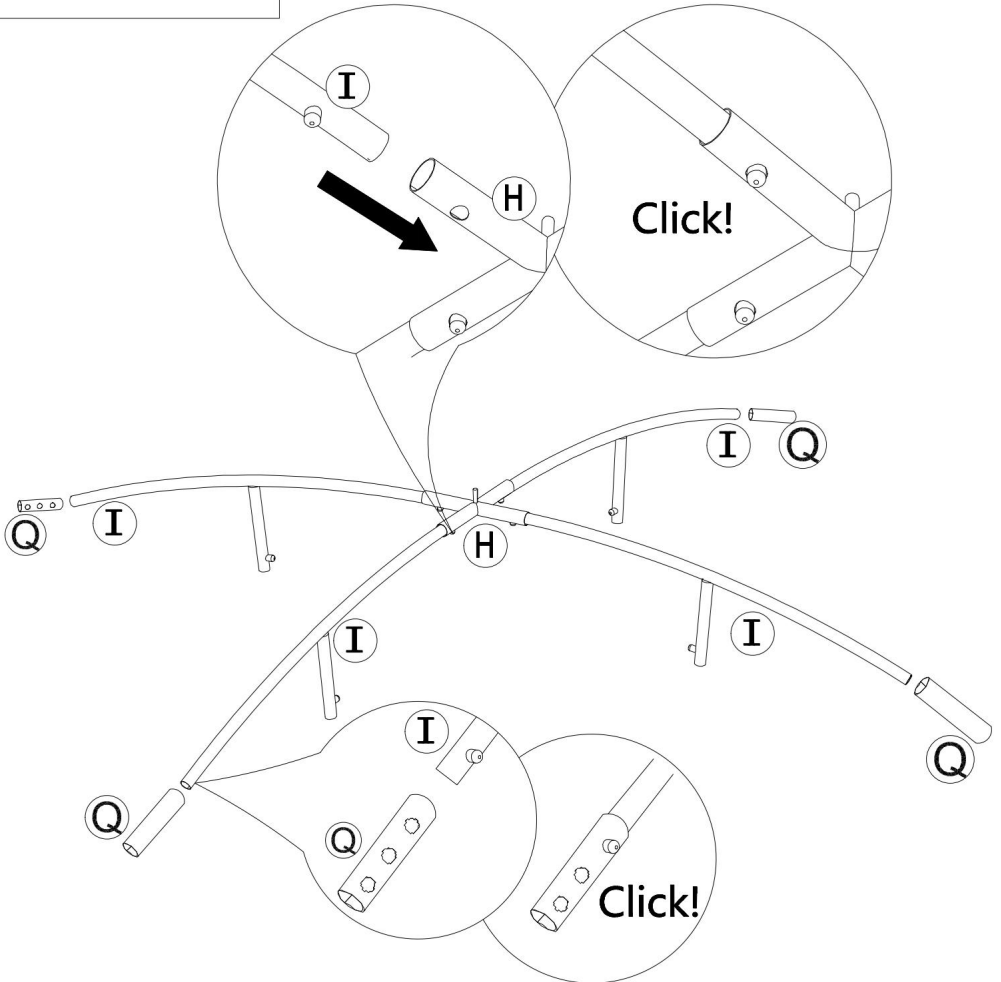
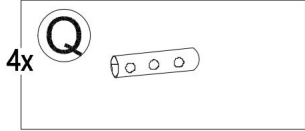
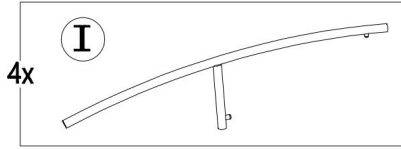
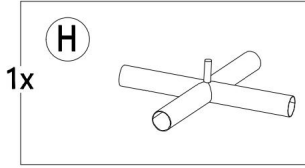

16

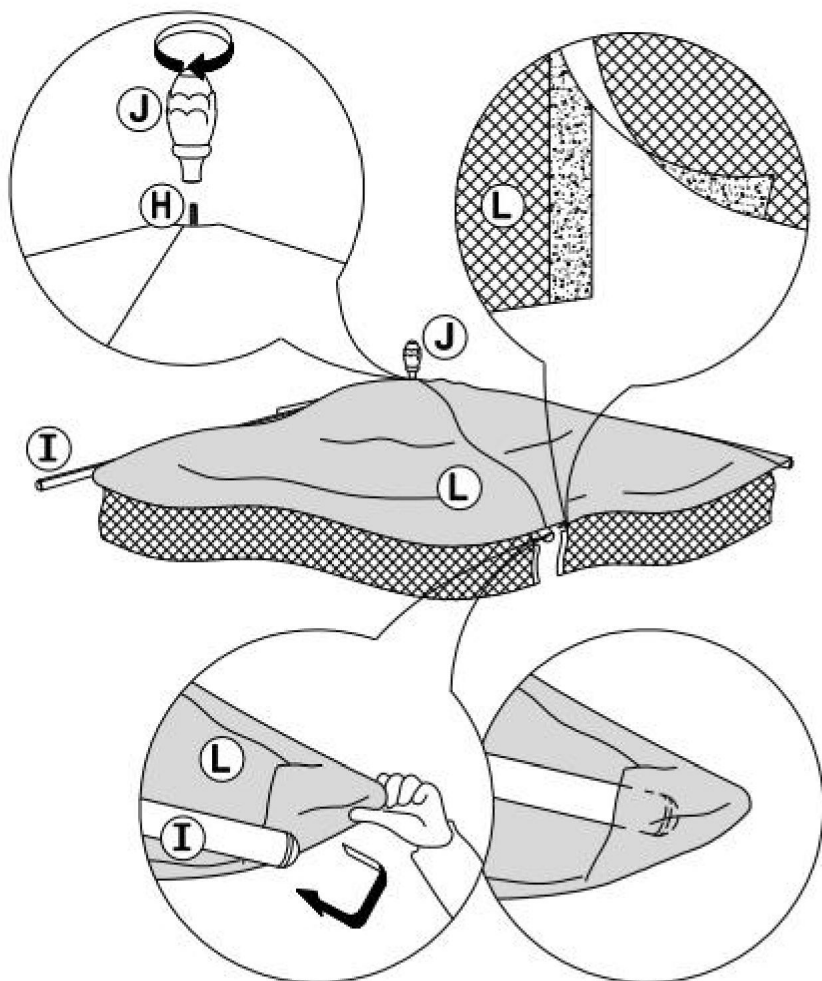
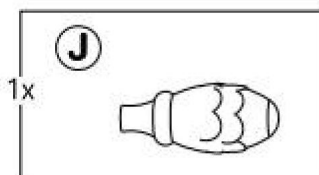
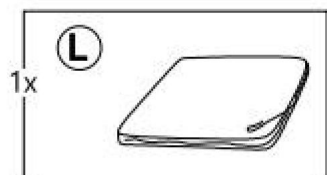

17

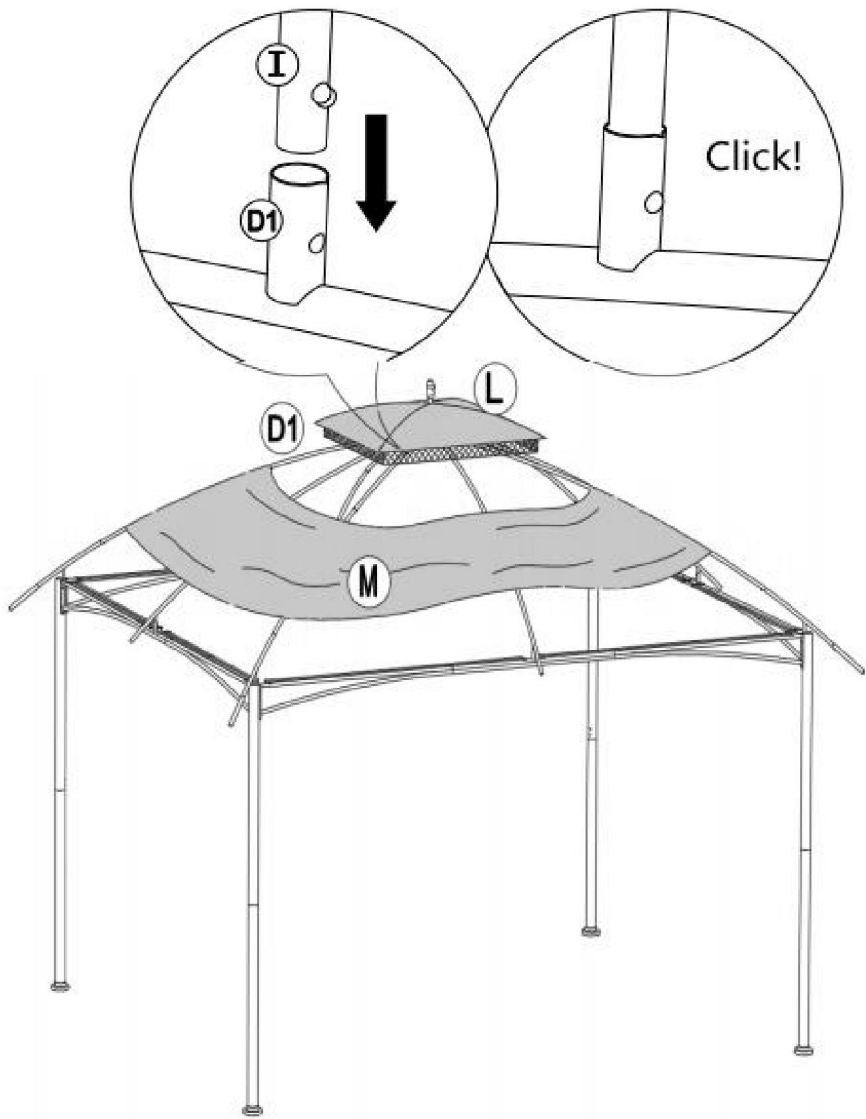

18

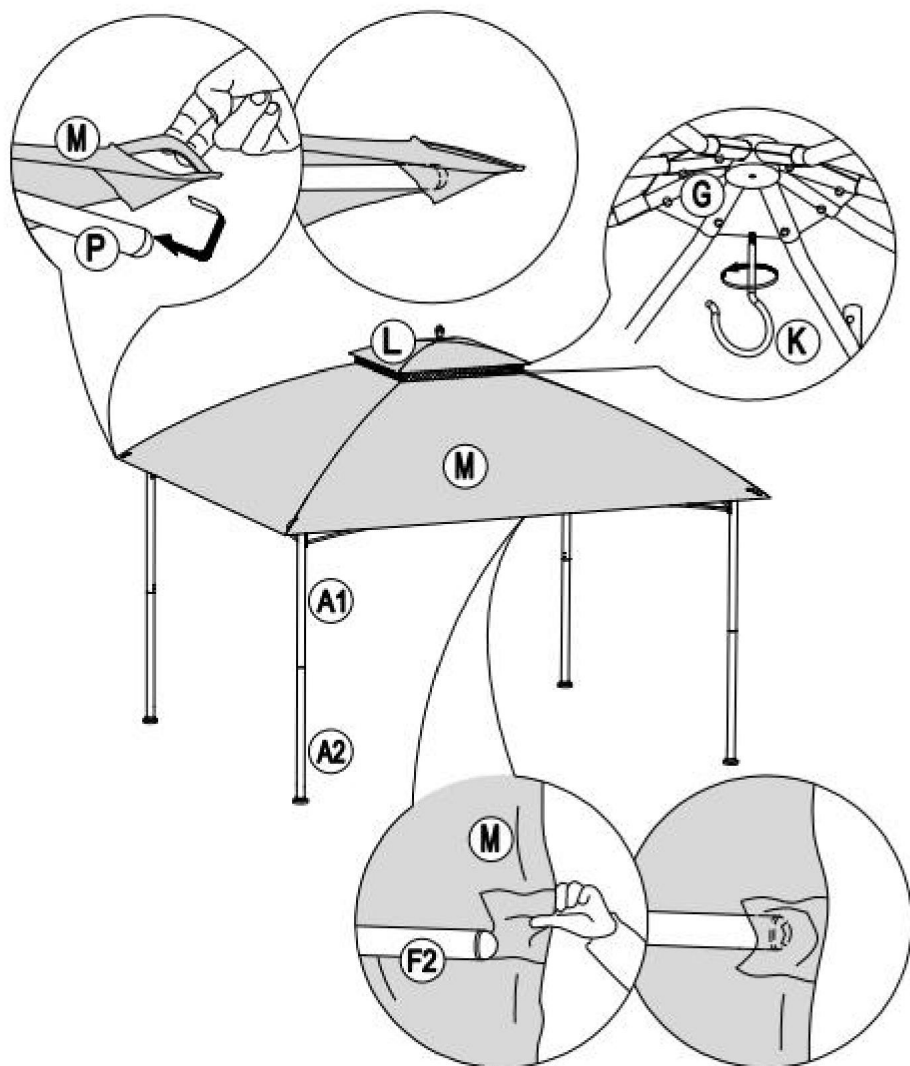
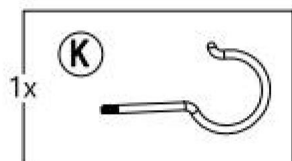

19

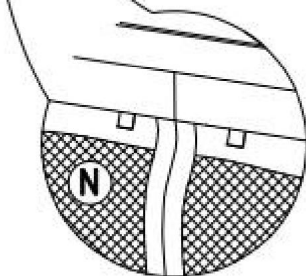
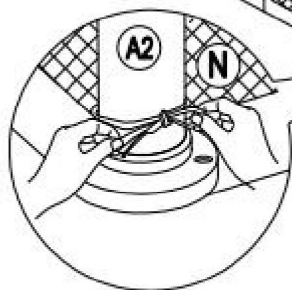
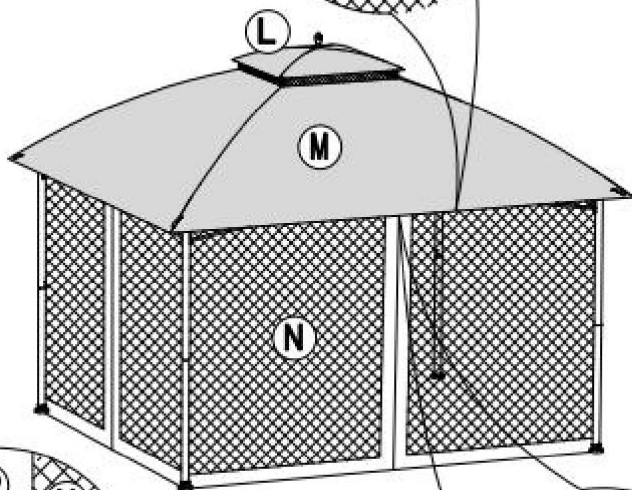
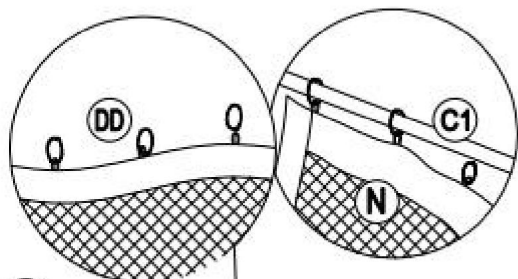
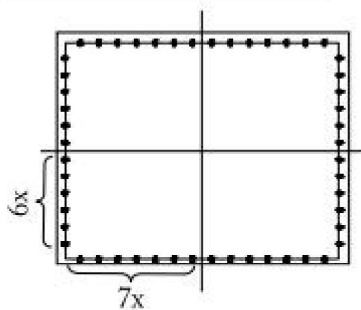
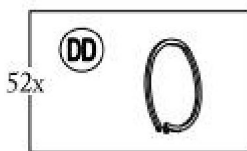
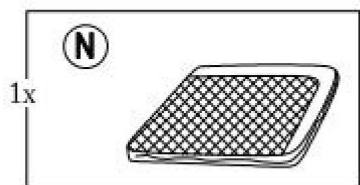

20

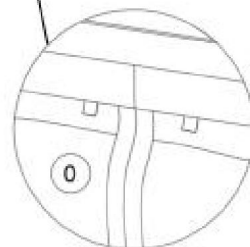
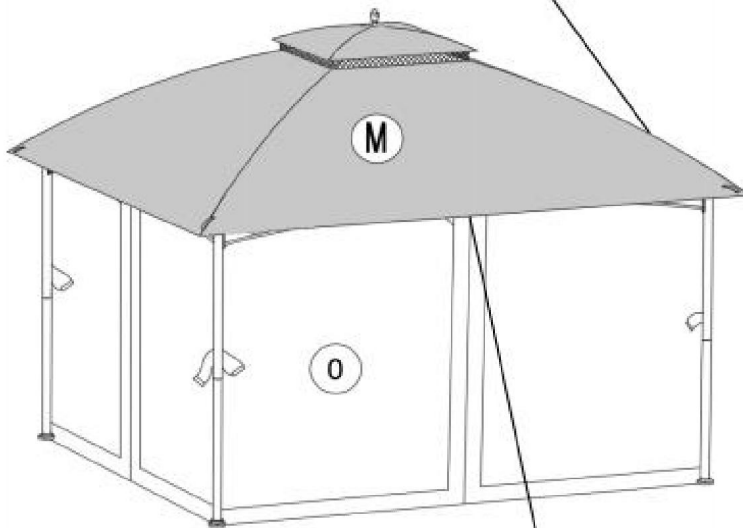
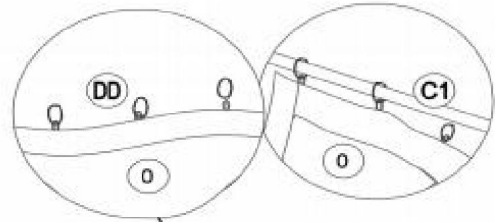
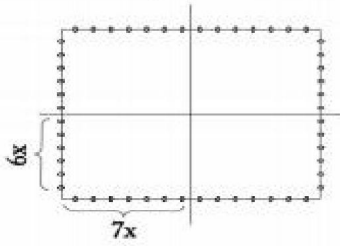
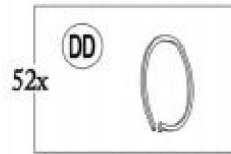
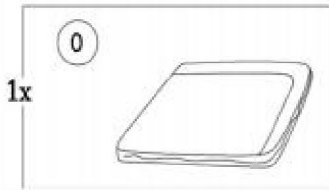

21

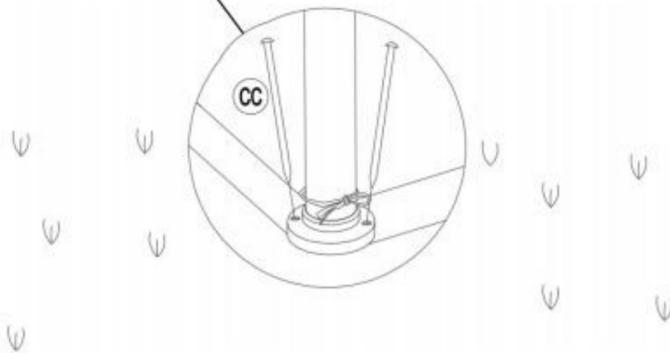
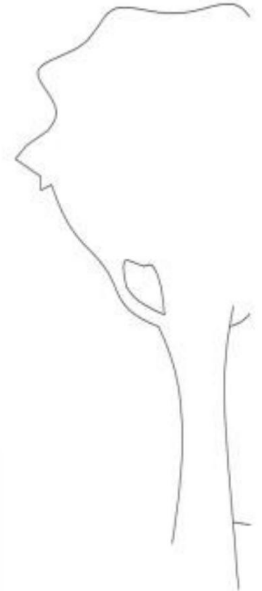
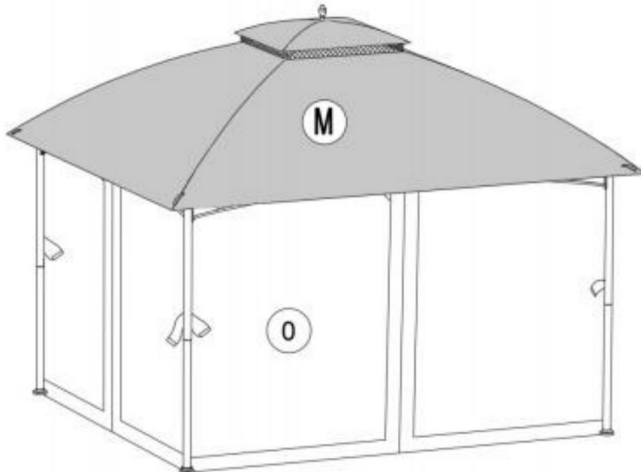

Importé aux États-Unis : Sanven Technology Ltd.

Suite 250, 9166 Anaheim Place, Rancho Cucamonga, CA 91730

VEVOR®

TOUGH TOOLS, HALF PRICE

Assistance technique et certificat de garantie
électronique www.vevor.com/support

VEVOR[®]

TOUGH TOOLS, HALF PRICE

Technische ondersteuning en e-garantiecertificaat www.vevor.com/support

INSTRUCTIES VOOR PATIO GAZEBO'S

MODEL:KD-TY007-1

Wij streven er voortdurend naar om u gereedschappen tegen concurrerende prijzen te leveren.

"Bespaar de helft", "halve prijs" of andere soortgelijke uitdrukkingen die wij gebruiken, geven slechts een schatting weer van de besparingen die u kunt behalen door bepaalde gereedschappen bij ons te kopen in vergelijking met de grote topmerken en betekent niet noodzakelijkerwijs dat alle categorieën gereedschappen die wij aanbieden, worden gedekt.

Wij herinneren u eraan om zorgvuldig te controleren of u daadwerkelijk de helft bespaart in vergelijking met de grote topmerken wanneer u een bestelling bij ons plaatst.

VEVOR[®]

TOUGH TOOLS, HALF PRICE

PATIO GAZEBO'S

KD-TY007-1

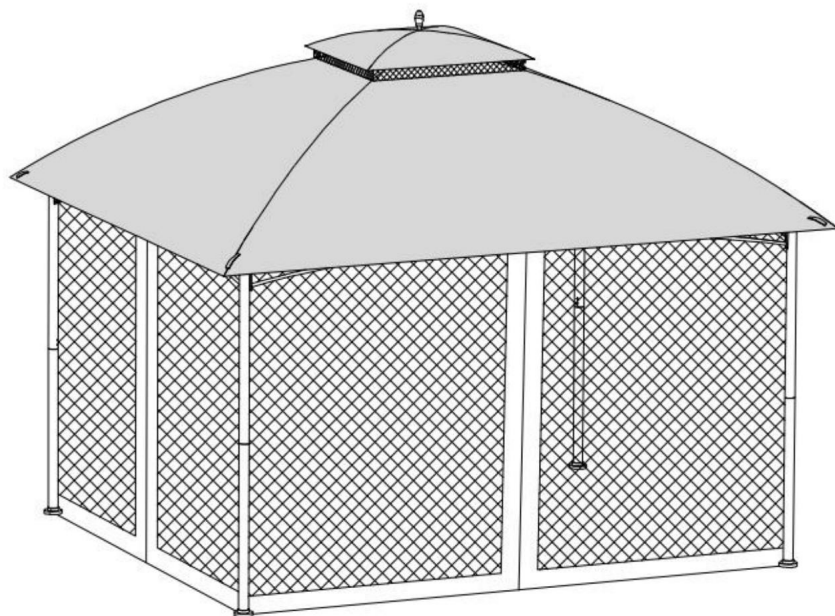

HULP NODIG? NEEM CONTACT MET ONS OP!

Heeft u vragen over het product? Heeft u technische ondersteuning nodig? Neem dan gerust contact met ons op:

Technische ondersteuning en e-garantiecertificaat www.vevor.com/support

Dit is de originele instructie, lees alle handleidingen zorgvuldig door voordat u het product gebruikt. VEVOR behoudt zich een duidelijke interpretatie van onze gebruikershandleiding voor. Het uiterlijk van het product is afhankelijk van het product dat u hebt ontvangen. Vergeef ons dat we u niet opnieuw zullen informeren als er technologie- of software-updates voor ons product zijn.

MONTAGE- EN VEILIGHEIDSINSTRUCTIES

Om het risico te verkleinen, dient u de volgende instructies nauwkeurig op te volgen.
van verwondingen, ongevallen of schade aan het product zelf.

BELANGRIJK

Volg ALLE onderstaande veiligheidsinstructies.

Verwijder het verpakkingsmateriaal voordat u het product monteert of gebruikt.

Zorg ervoor dat alle vermelde onderdelen in het pakket zitten en dat ze
niet beschadigd.

Lees deze montage- en veiligheidsinstructies zorgvuldig door voordat u het product gebruikt.
tent en bewaar deze voor toekomstig gebruik.

Dit product mag uitsluitend voor niet-commerciële doeleinden worden gebruikt.

VEILIGHEIDSINFORMATIE

De tent is niet getest op wind- en sneeuwbelasting, tenzij dat duidelijk is aangegeven
anders. Daarom vallen deze ladingen niet onder de garantie. Bekijk de
weersvoorspellingen om de tent goed te kunnen beschermen of demonteren voordat
problemen ontstaan.

Tenten mogen alleen als tijdelijke accommodatie worden gebruikt en moeten
gedemonteerd onder ongunstige weersomstandigheden.

Zorg ervoor dat u voldoende afstand houdt tot huizen en gas- en elektriciteitsleidingen om
vermijd mogelijke schade. Controleer het gebied op stroomkabels en gasleidingen.

Vraag indien nodig meer informatie aan bij uw gemeente.

Bij gebruik van geschikte verwarmingstoestellen dient u een minimale afstand van 1,2 m tot het zeil aan te houden
materiaal. Open vuur of kachels met open vlammen zoals terrasverwarmers, parasols
Verwarmingstoestellen, gaskachels etc. mogen in geen geval in de tent worden gebruikt.

Degene die de opbouw van de tent verzorgt, is verantwoordelijk voor een adequate het vastzetten om de veiligheid ervan te garanderen. Controleer de verankering voortdurend om te voorkomen schade. Een stabiele verankering kan de duurzaamheid van de tent verlengen.

Om uw eigen veiligheid te garanderen, verzoeken wij u handschoenen te dragen. De metalen onderdelen kunnen scherpe randen hebben en door roest vettig zijn preventieve behandeling.

Zorg ervoor dat er geen permanente sneeuwlast is. Deze moet worden verwijderd direct. Hetzelfde geldt voor regen en andere vormen van belasting.

Waarschuwing - houd plastic en kleine reserveonderdelen buiten bereik van kinderen. Een dunne film kan aan de neus en mond blijven plakken en de ademhaling belemmeren.

MONTAGE & GEBRUIK

Reserveer alstublieft wat meer tijd voor uw eerste installatie van de tent. De regels die u moet volgen gevolgd bij het opzetten van de tent zijn eenvoudig. Gebruik de illustratieve instructies voor elke stap van de installatie.

De schroeven die de buizen met de connectoren verbinden, moeten handmatig worden vastgedraaid met behulp van een inbussleutel of een automatische schroevendraaier, ingesteld op max. stand 2, om materiaalschade te voorkomen dragen.

De tent mag alleen door minimaal twee volwassenen worden opgezet. Houd kinderen uit de buurt van de tent houden tijdens het opzetten ervan, om ze te beschermen.

Zorg ervoor dat u een vlakke en egale ondergrond vindt die geschikt is voor de montage van het product en het beoogde gebruik ervan.

Gebruik uitsluitend de materialen die bij de tent zijn meegeleverd.

De zeilen mogen niet in contact komen met voorwerpen met scherpe randen.

De tent kan worden gebruikt bij temperaturen dicht bij het vriespunt. Echter, voorafgaand aan dergelijke gebruik, moet het zeilmateriaal worden opgeslagen bij een temperatuur van ten minste 10°C. Gelieve Zorg ervoor dat het zeil niet kapotgaat als u het opvouwt.

Elk land heeft verschillende regels met betrekking tot verplaatsbare constructies (tenten) en onbeweegbare structuren. Vraag uw lokale autoriteiten of een vergunning moet worden verkregen om de tent op te zetten. In sommige landen is dit afhankelijk van de grootte van de tent.

ZORG- EN OPSLAGINSTRUCTIES

Schade door natuurrampen (weerschade) is niet gedekt.

De tent kan worden gebruikt bij temperaturen dicht bij het vriespunt. Echter, voorafgaand aan dergelijke gebruik, moet het zeilmateriaal worden opgeslagen bij een temperatuur van ten minste 10°C. Gelieve Zorg ervoor dat het zeil niet kapotgaat als u het opvouwt.

Sterke wind kan het product beschadigen. Verlaat de gazebo niet. gedurende een langere tijd onbeheerd achterlaat.

Blootstelling aan zonlicht kan ervoor zorgen dat de kleur van het zeil vervaagt. Dit heeft geen hebben invloed op de bruikbaarheid van de vuurkorf en worden niet beschouwd als een productdefect.

Bij hevige of langdurige regenval kunnen er waterzakken op het dak ontstaan. Deze zakjes moeten zo snel mogelijk verwijderd worden.

Gebruik geen agressieve chemicaliën om het zeilmateriaal schoon te maken. Het beste Reinigingsmiddel is water met een licht alkalische reactie.

Breng geen wijzigingen aan in de metalen structuur van de tent, zoals: bijvoorbeeld het aansluiten en/of lassen van extra lasten, het maken van groeven en/of eventuele vervormingen.

Verwijder het zeil als u het product niet gebruikt, om schade te voorkomen.

Wij adviseren u om bij slecht weer het paviljoen af te breken en de winterseizoenen.

De tent/tarp mag alleen worden opgevouwen, ingepakt en opgeborgen als deze volledig droog is. Doe dit alstublieft. Leg geen andere voorwerpen op de tent/het zeil wanneer deze is opgeborgen.

SPECIFICATIES

Model	KD-TY007-1
Product Size	2970×3920×3530mm
Color	Beige/Brown/Black

HULPMIDDELEN

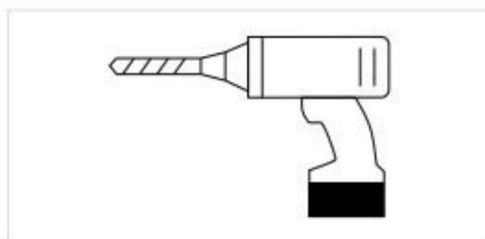





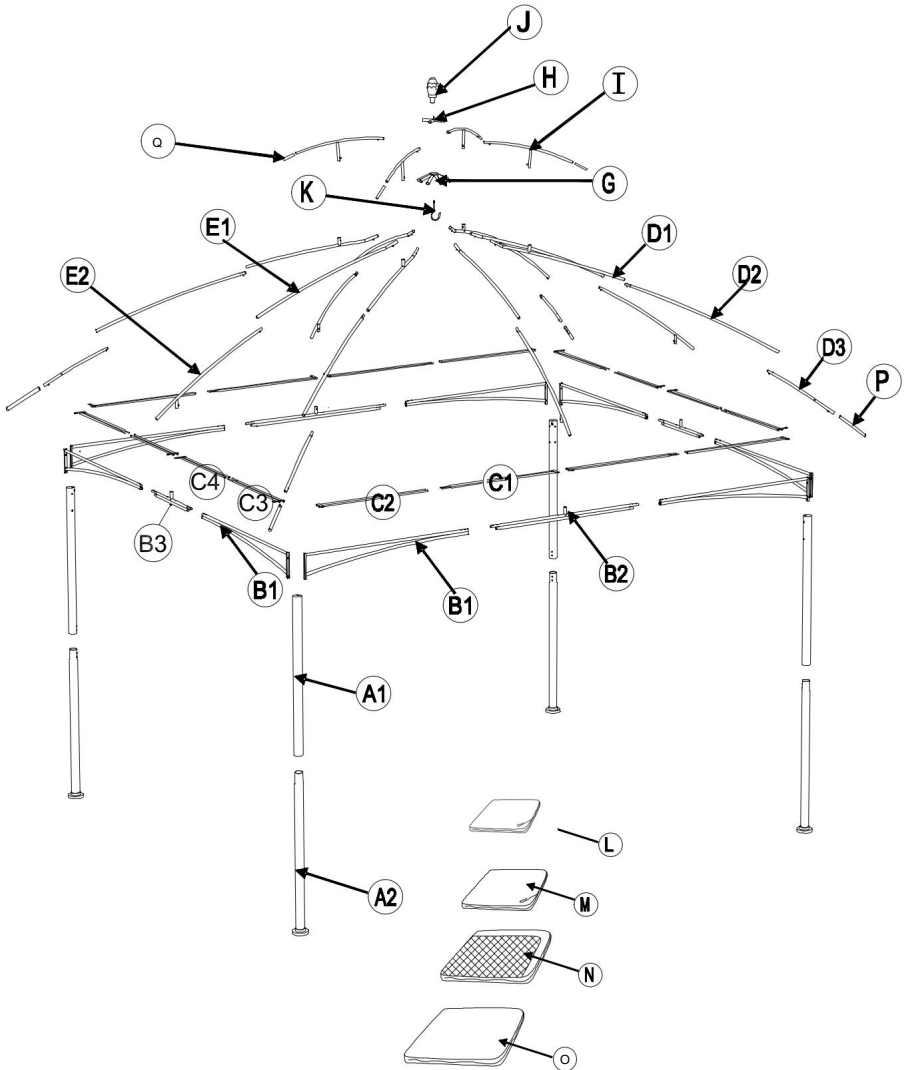
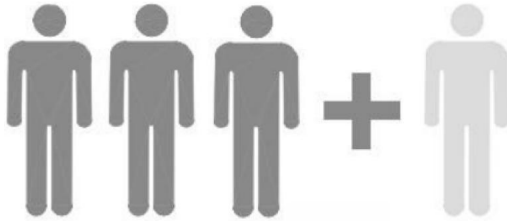



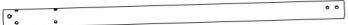

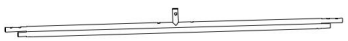
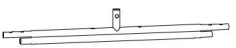













IMPORTANT





People needed for installation work

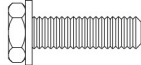
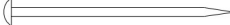

Parts List

Label	Qty	Part Image
A1	4	
A2	4	
B1	8	
B2	2	
B3	2	
C1	4	
C2	4	
C3	4	
C4	4	
D1	4	
D2	4	
D3	4	
E1	2	
E2	2	
F1	2	
F2	2	
G	1	
H	1	

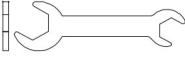
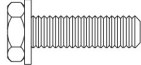
Parts list		
Label	Qty	Parts Image
I	4	
J	1	
K	1	
L	1	
M	1	
N	1	
P	4	
O	1	
Q	4	

Parts list				
Label	Description	Qty	Add	Parts Image
AA	M5*15	24	2	
BB	M6*20	40	2	
CC	Φ8*180	8	0	
DD	/	104	3	
EE	M5/M6	1	0	
FF	M6*35	4	1	
GG	M6	4	1	

1

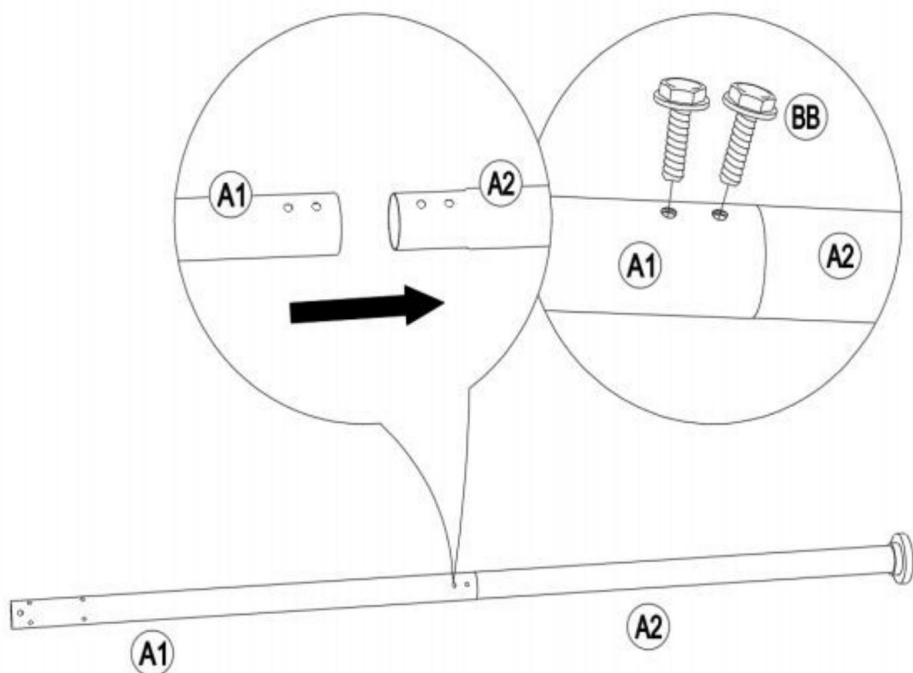
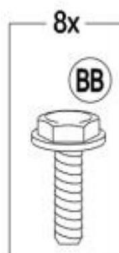
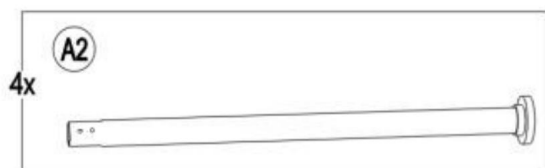

2

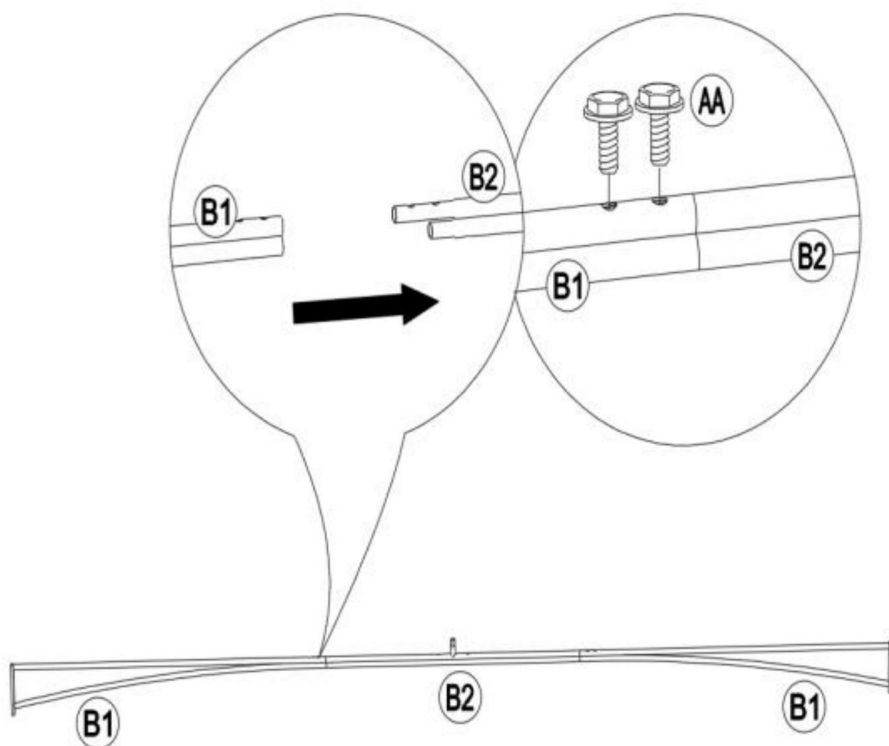
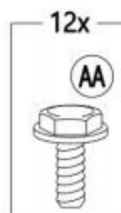
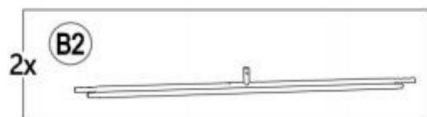
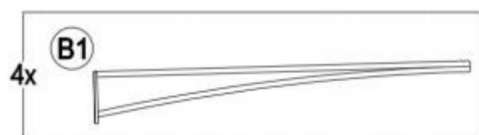

3

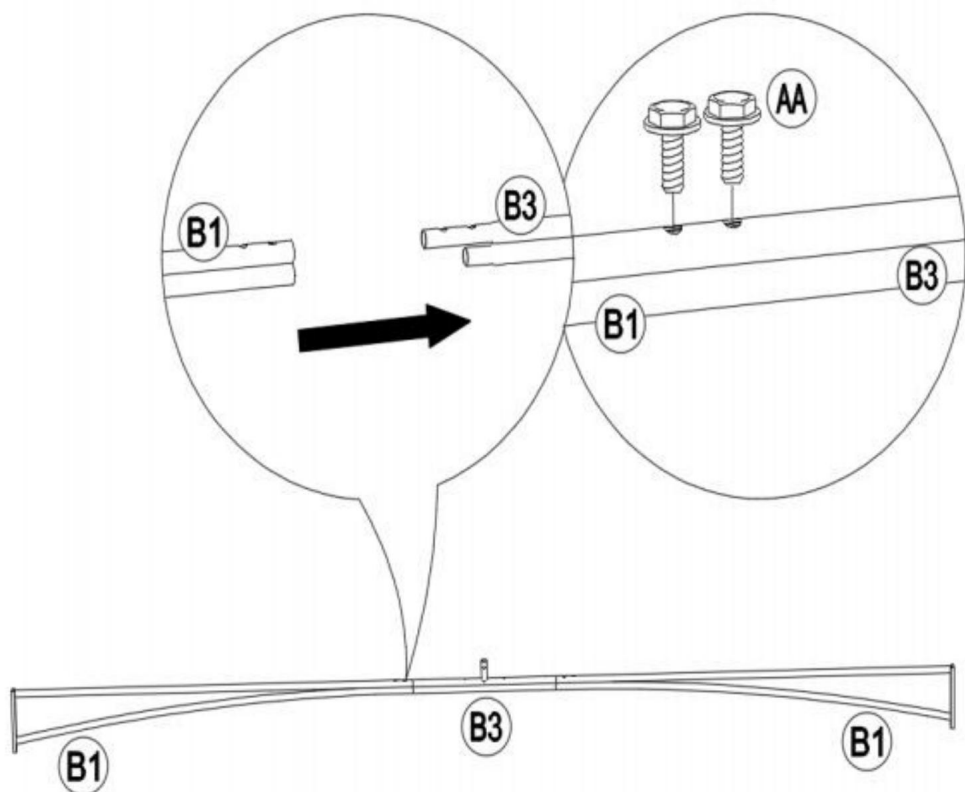
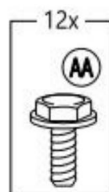
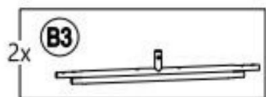
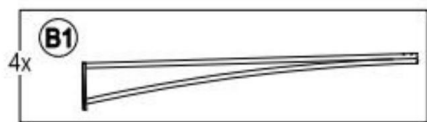

4

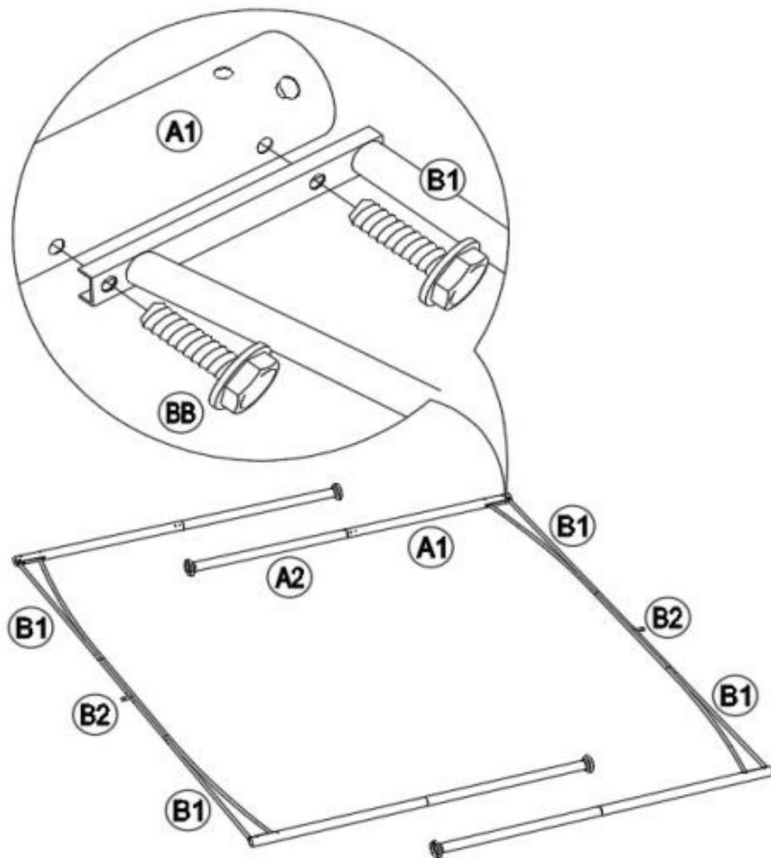
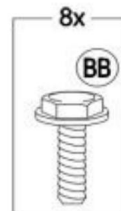
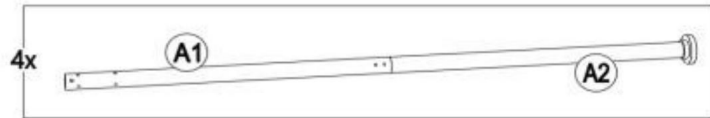
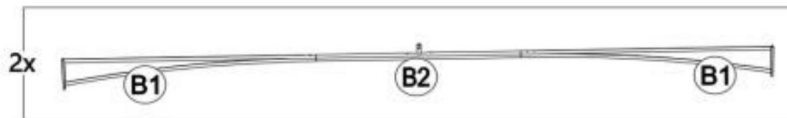

5

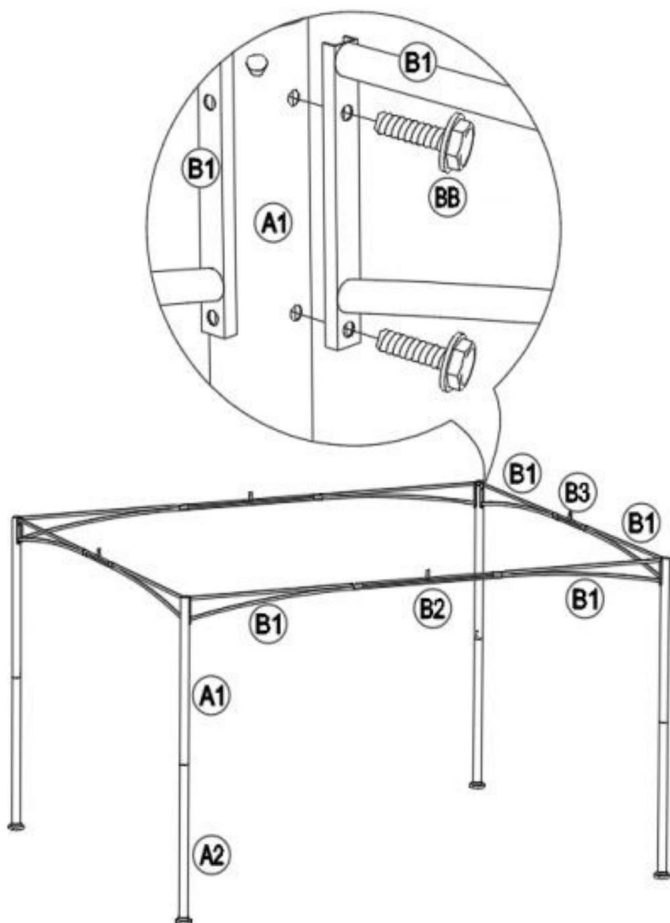
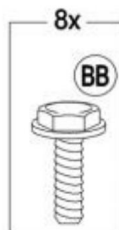
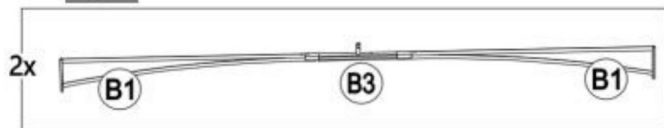

6

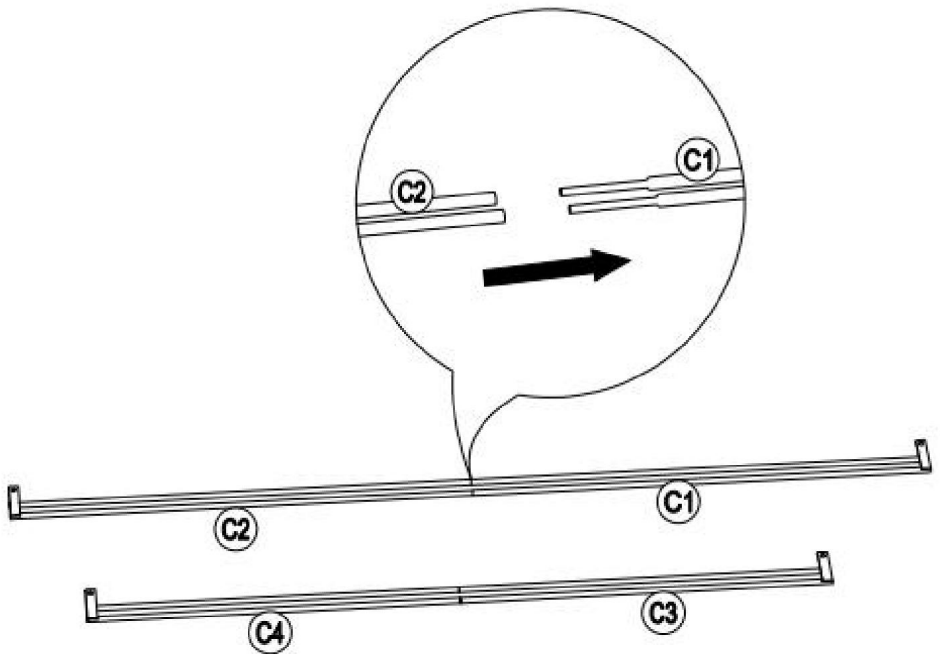
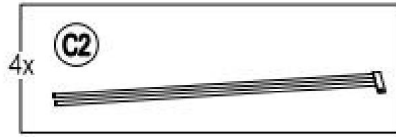
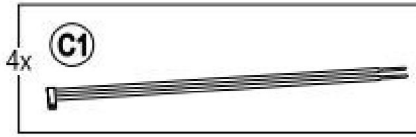

7

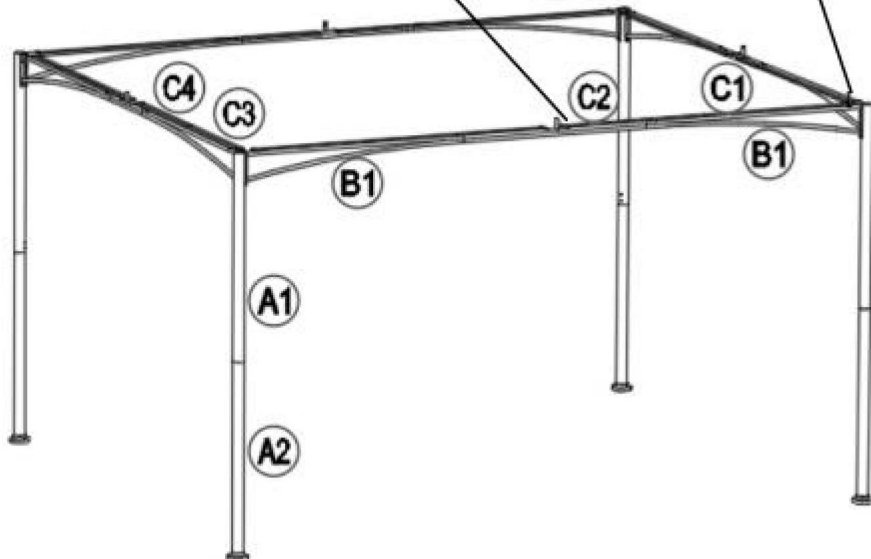
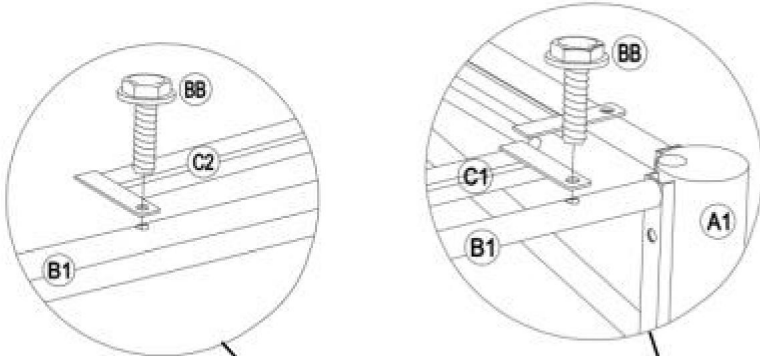
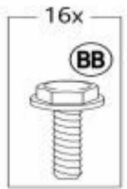

8

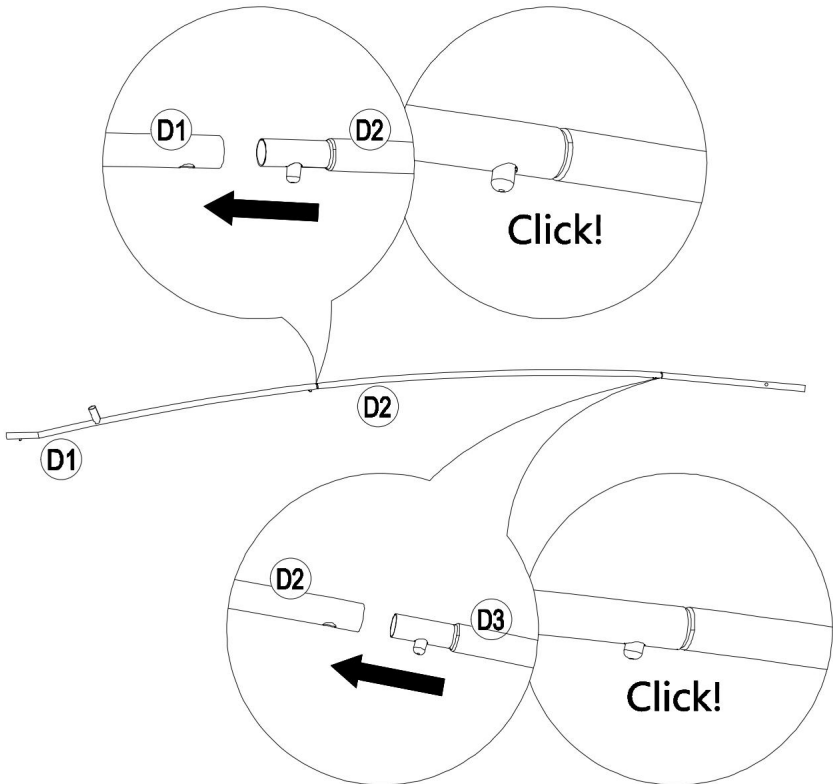
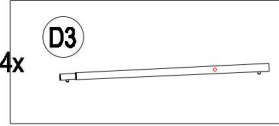
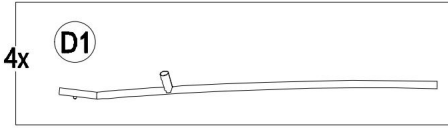

9

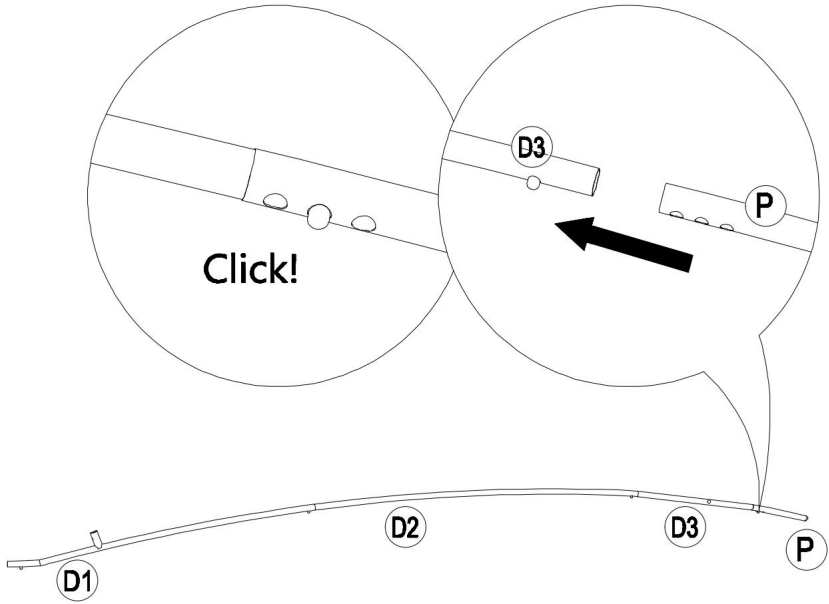
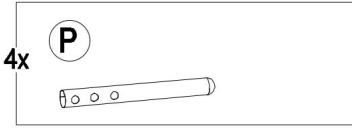

10

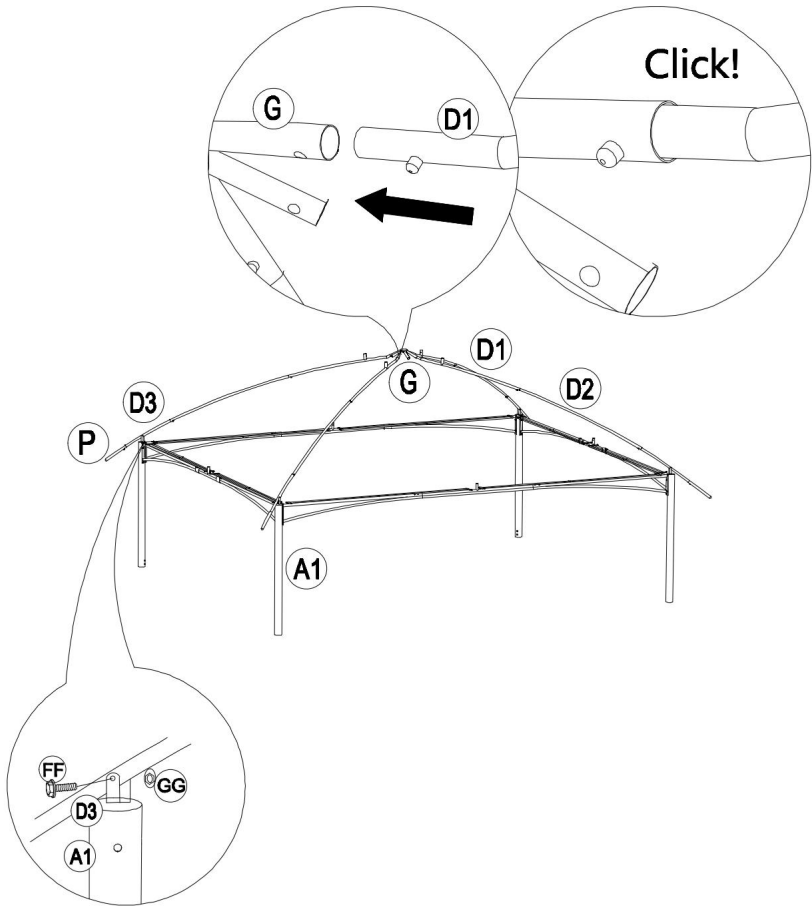
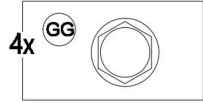
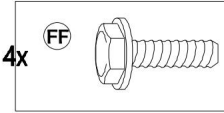
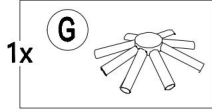
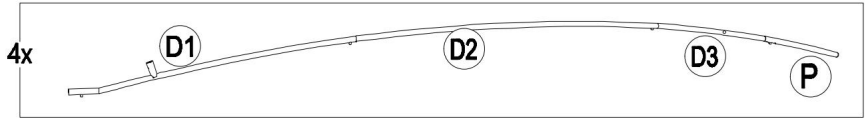

11

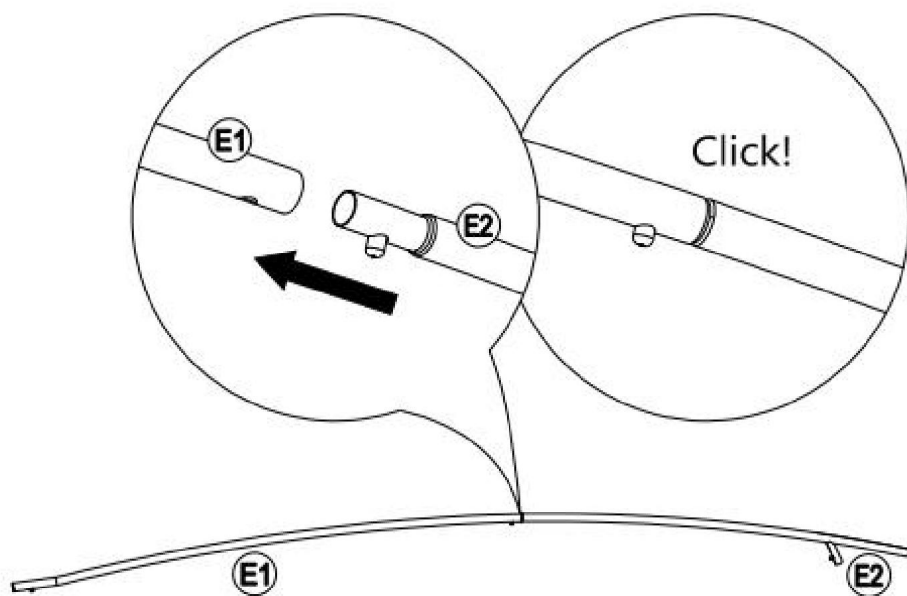

12

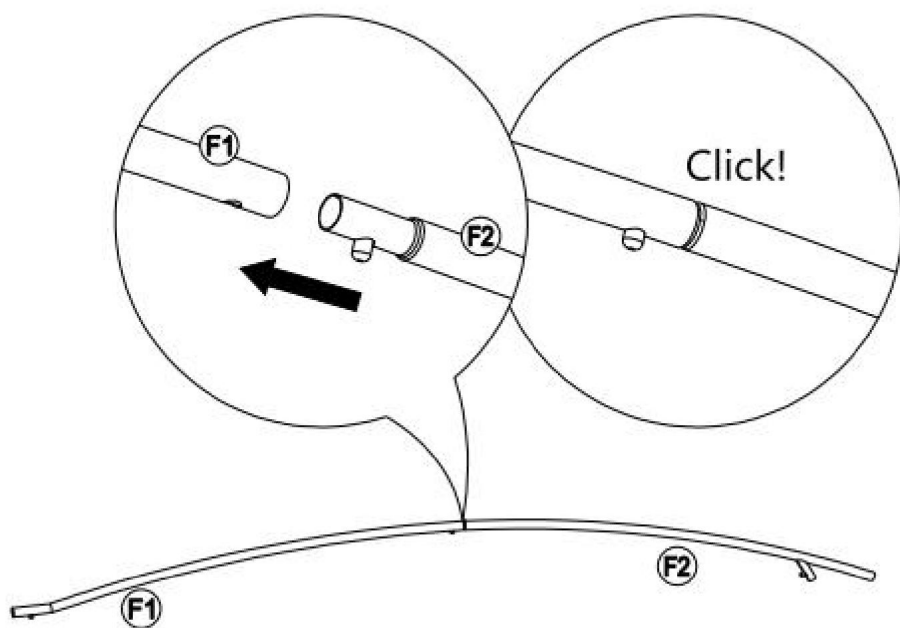
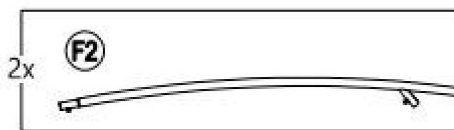
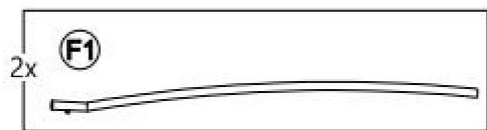

13

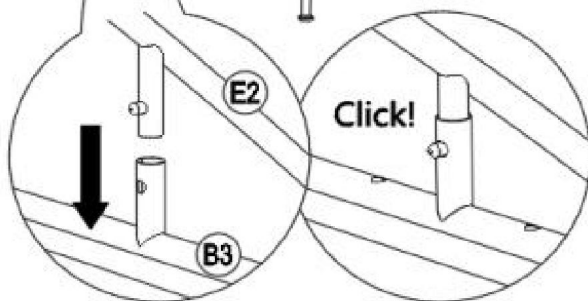
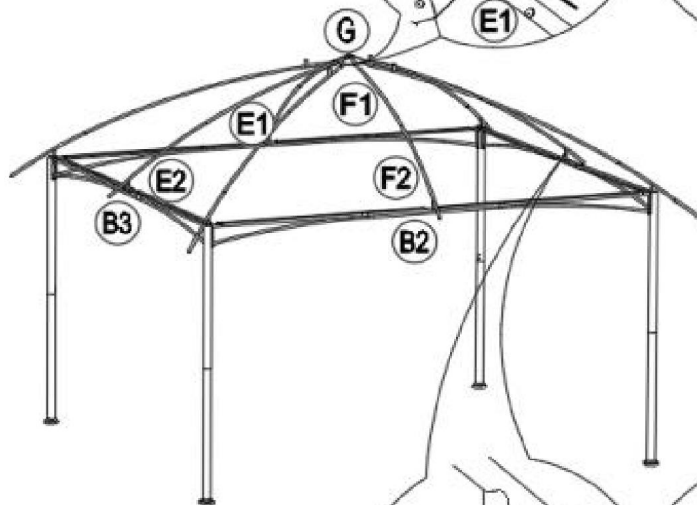
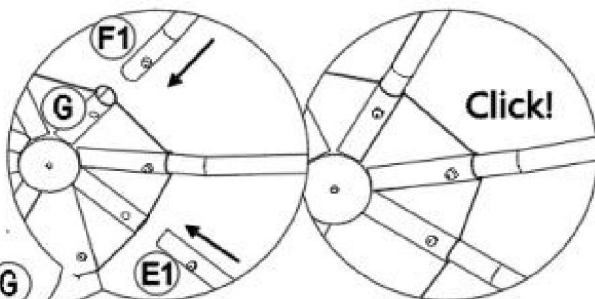
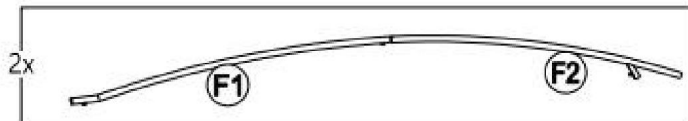
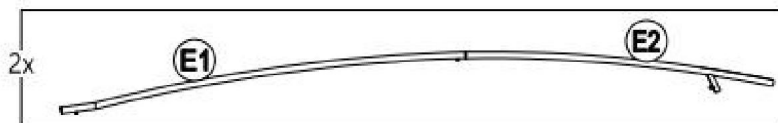

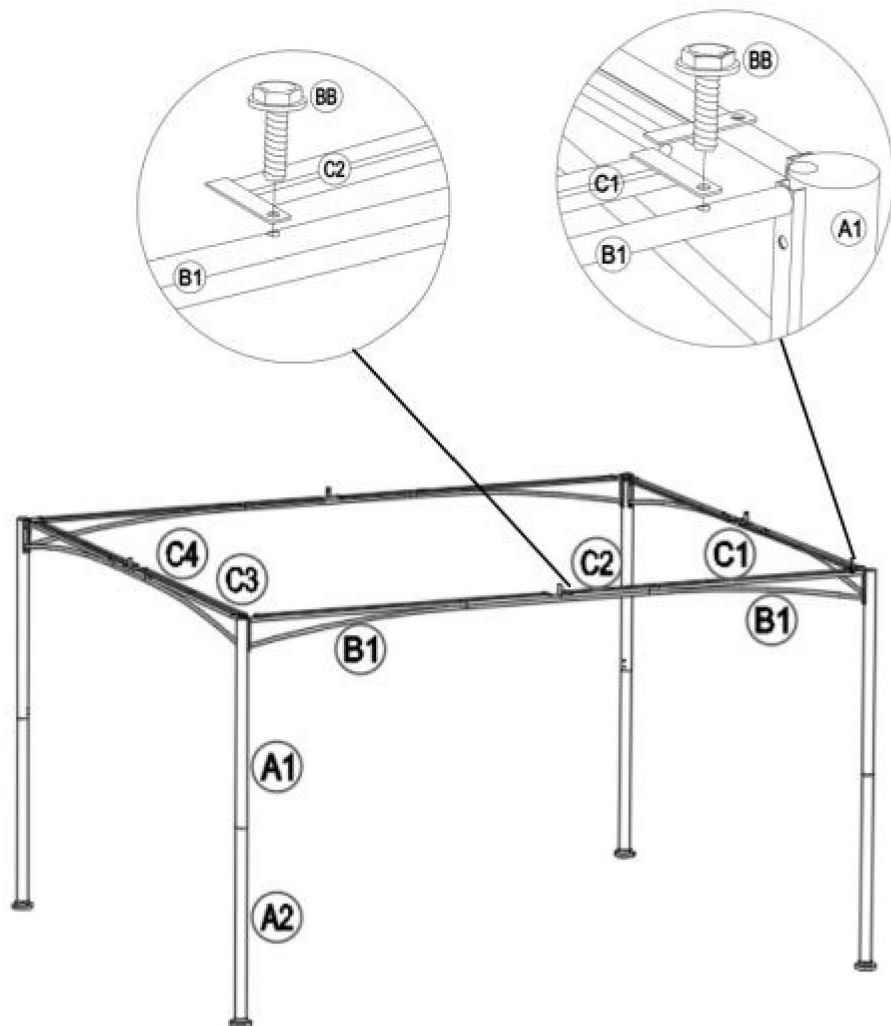

14

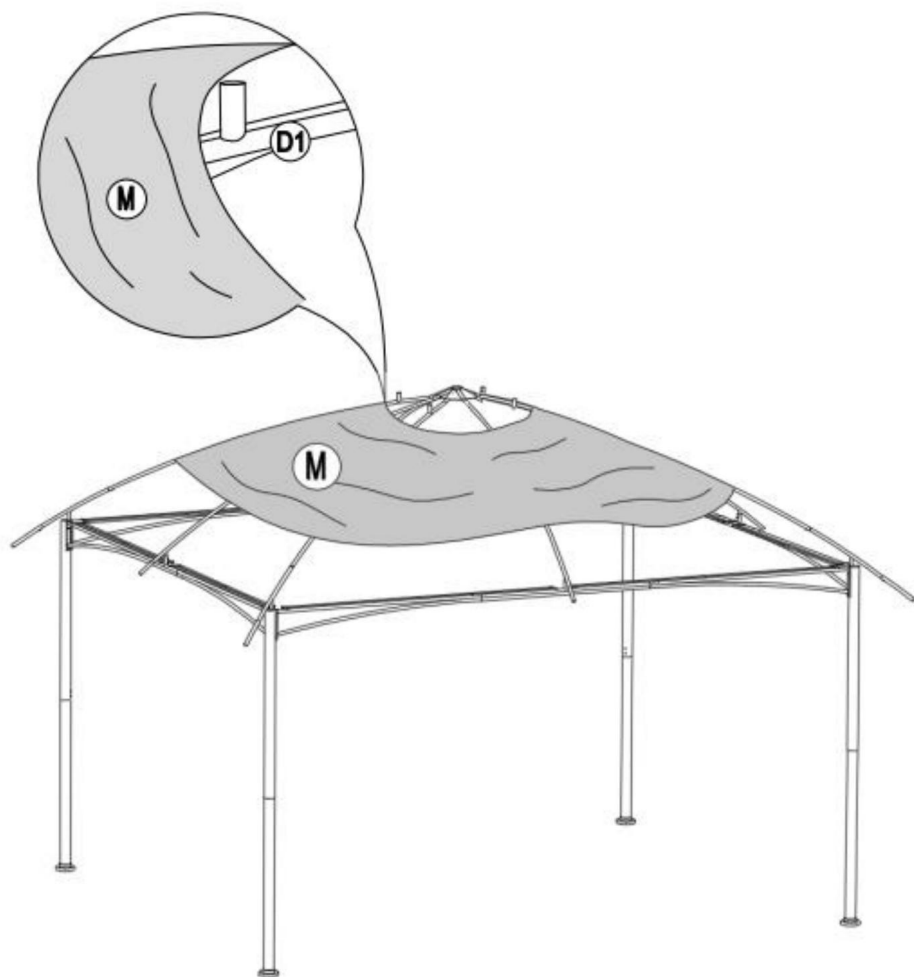
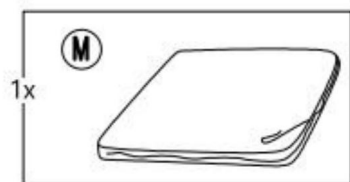

15

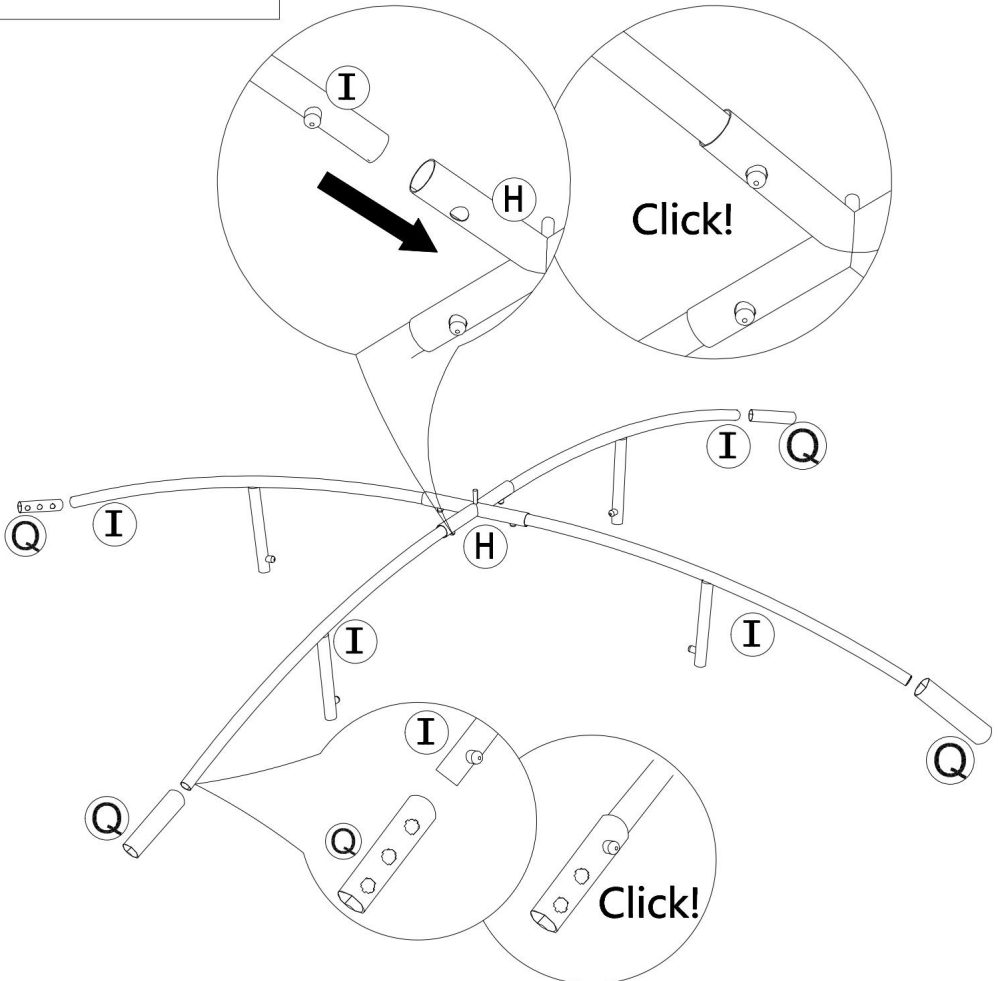
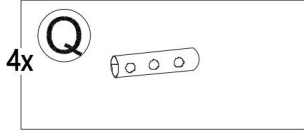
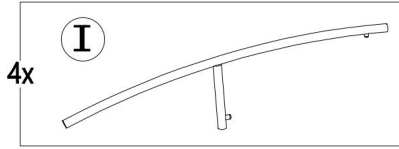
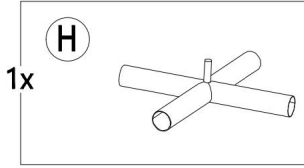

16

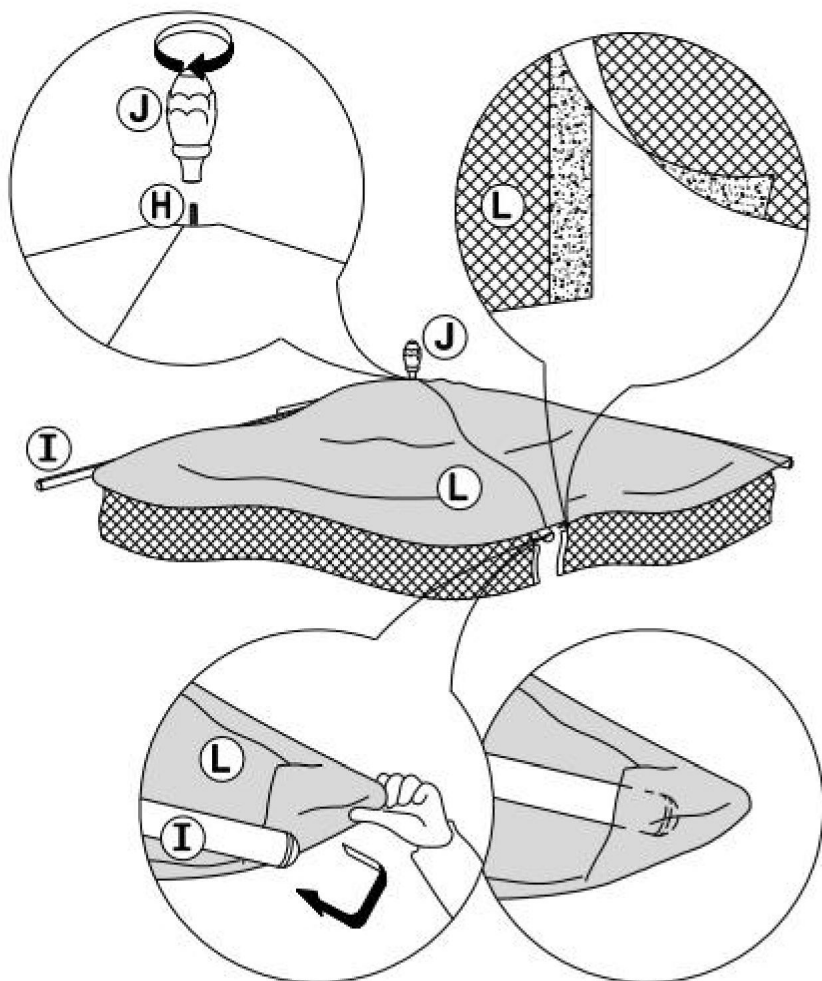
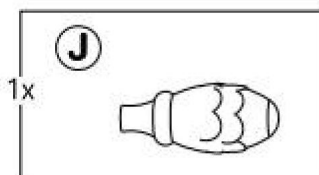
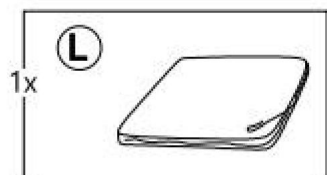

17

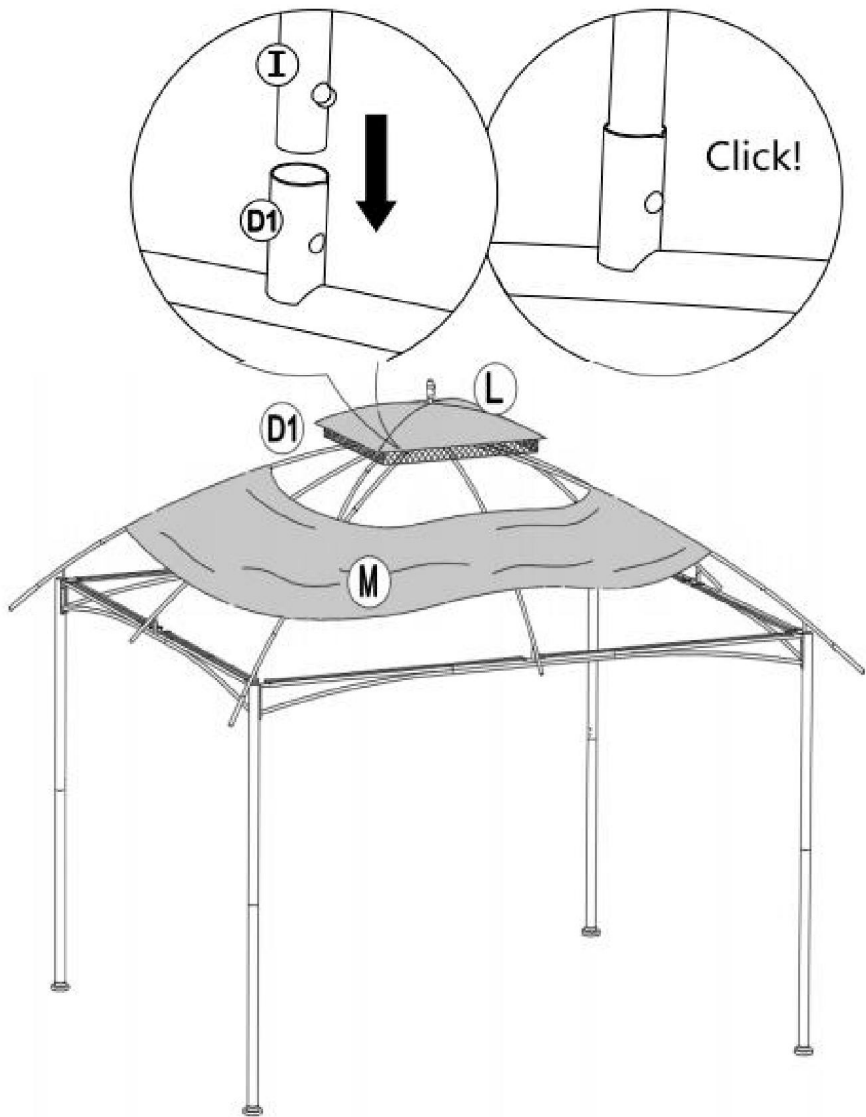

18

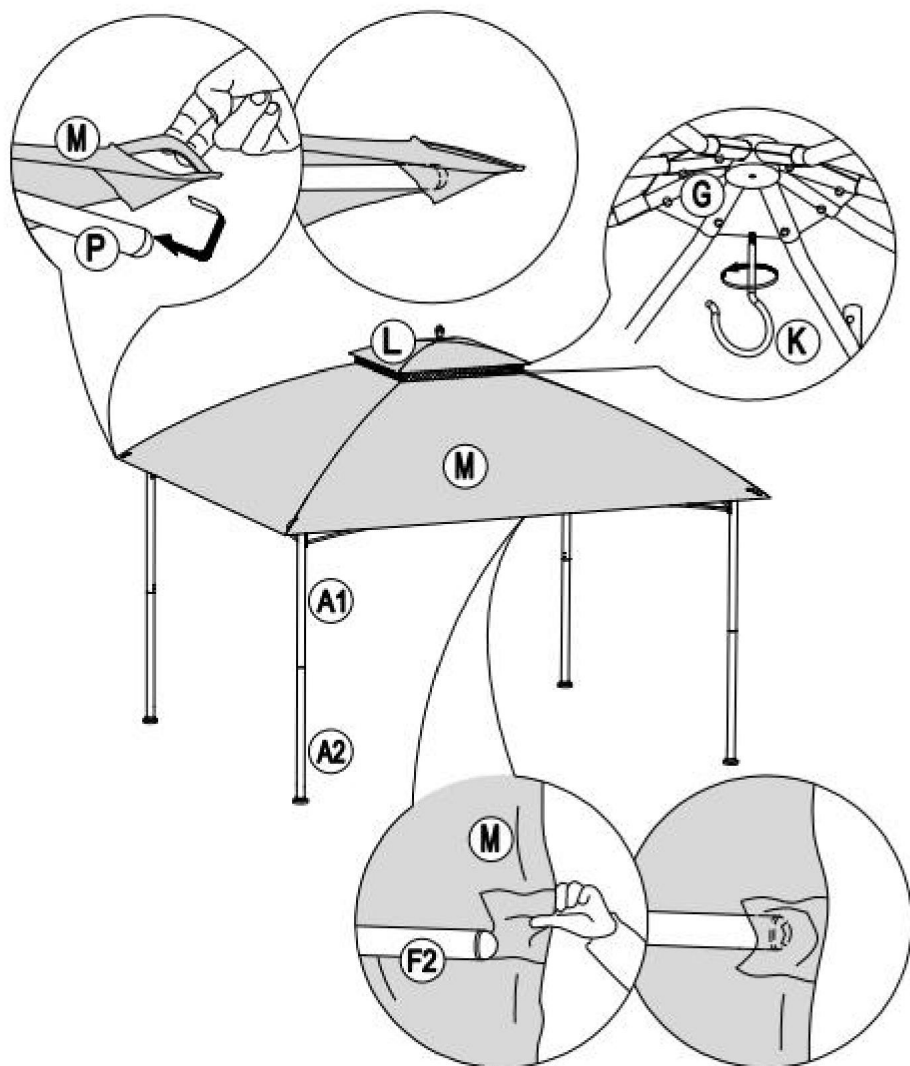
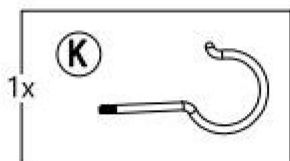

19

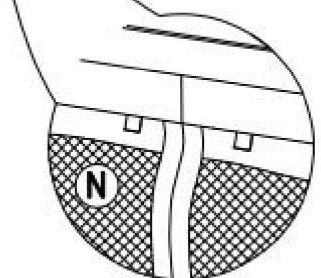
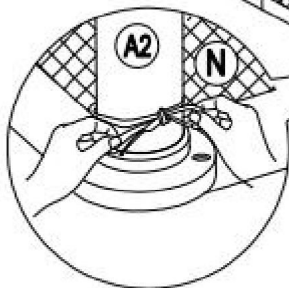
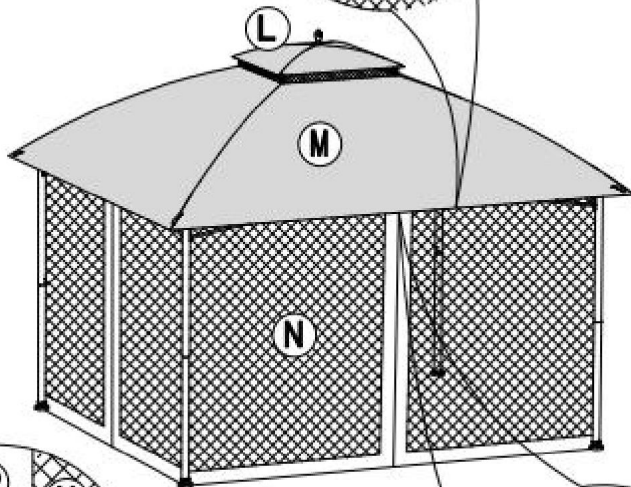
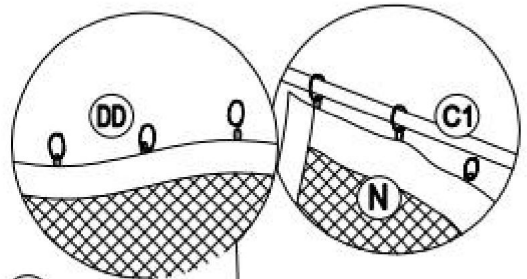
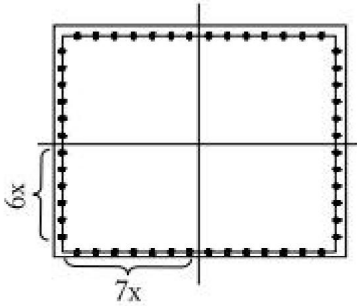
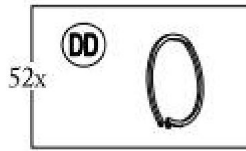
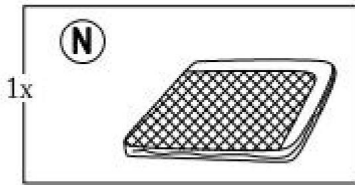

20

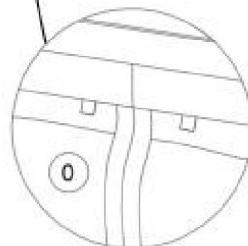
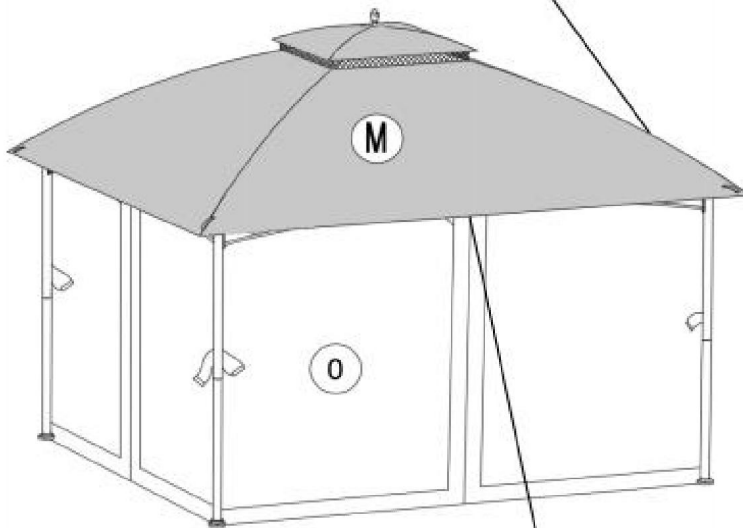
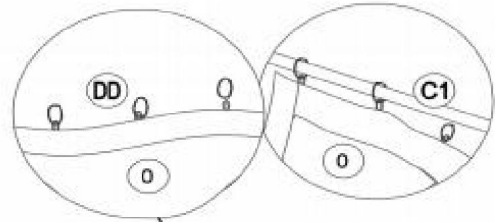
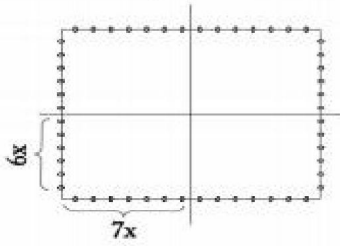
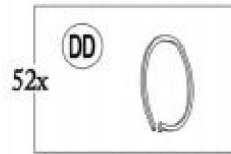
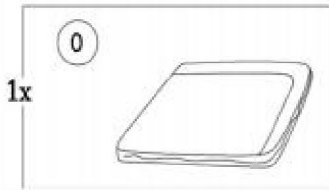

21

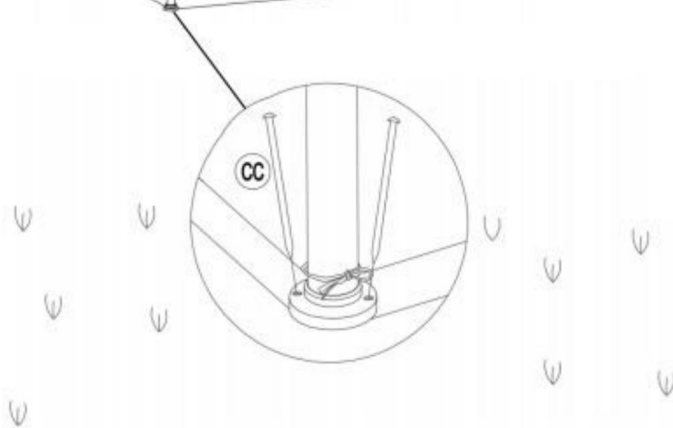
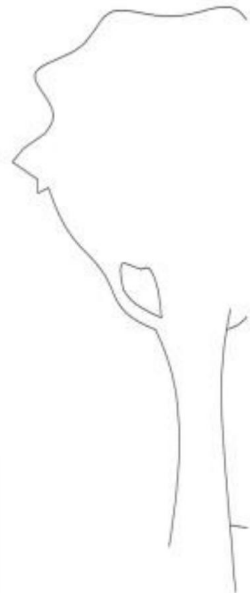
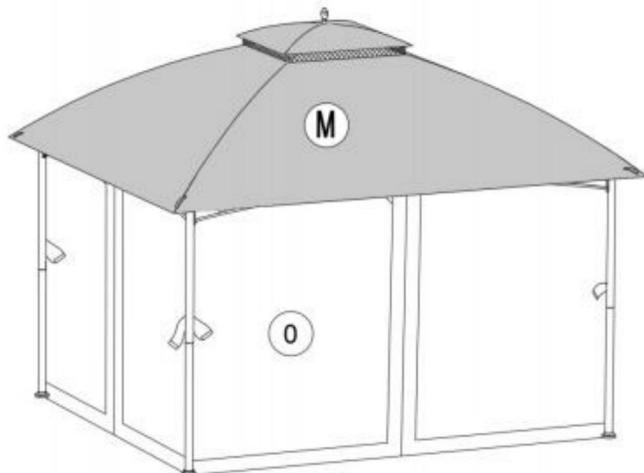

Geïmporteerd naar de VS: Sanven Technology Ltd.
Suite 250, 9166 Anaheim Place, Rancho Cucamonga, CA 91730

VEVOR[®]

TOUGH TOOLS, HALF PRICE

**Technische ondersteuning en e-
garantiecertificaat www.vevor.com/support**

VEVOR[®]

TOUGH TOOLS, HALF PRICE

Teknisk support och e-garanticertifikat www.vevor.com/support

INSTRUKTION FÖR UTPLATTNINGSSSTJUDAN

MODELL:KD-TY007-1

Vi fortsätter att vara engagerade i att ge dig verktyg till konkurrenskraftiga priser.

"Spara hälften", "halva priset" eller andra liknande uttryck som används av oss representerar bara en uppskattning av besparingar du kan dra nytta av att köpa vissa verktyg hos oss jämfört med de stora toppmärkena och betyder inte nödvändigtvis att täcka alla kategorier av verktyg som erbjuds av oss. Du påminns vänligen om att noggrant kontrollera när du gör en beställning hos oss om du faktiskt sparar hälften i jämförelse med de främsta stora varumärkena

VEVOR®

TOUGH TOOLS, HALF PRICE

PATIO GAZEBOS

KD-TY007-1

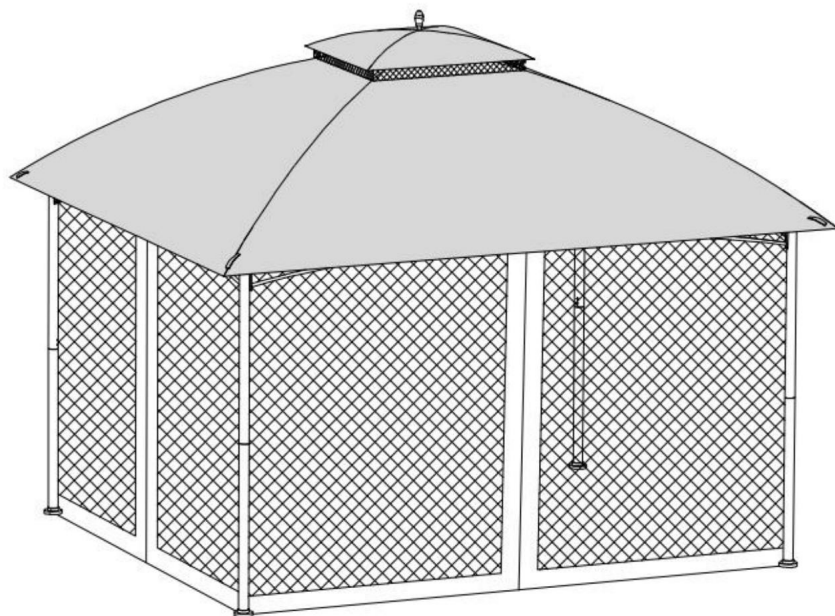

BEHÖVER HJÄLP? KONTAKTA OSS!

Har du produktfrågor? Behöver du teknisk support? Kontakta oss gärna:

Teknisk support och e-garanticertifikat www.vevor.com/support

Detta är den ursprungliga instruktionen, läs alla instruktioner noggrant innan du använder den. VEVOR reserverar sig för en tydlig tolkning av vår användarmanual. Utseendet på produkten är beroende av den produkt du fått. Ursäkta oss att vi inte kommer att informera dig igen om det finns någon teknik eller mjukvaruuppdateringar på vår produkt.

MONTERING OCH SÄKERHETSINSTRUKTIONER

Var noga med att följa följande instruktioner för att minska risken av skador, olyckor eller skador på produkten i sig.

VIKTIG

Följ ALLA säkerhetsinstruktioner nedan.

Ta bort förpackningsmaterialet innan du monterar eller använder produkten.

Se till att alla listade delar ingår i paketet och att de är det inte skadad.

Läs dessa monterings- och säkerhetsinstruktioner noggrant innan du använder den tält och spara det för framtida referens.

Denna produkt bör endast användas på ett icke-kommersiellt sätt.

SÄKERHETSINFORMATION

Tältet testades inte för vind- och snölast, om det inte är tydligt indikerat annat. Därför täcks dessa laster inte av garantin. Vänligen titta på väderprognoser för att kunna skydda eller demontera tältet ordentligt innan problem dyker upp.

Tält ska endast användas som tillfälligt boende och ska vara det demonteras i ogynnsamma väderförhållanden.

Se till att hålla tillräckligt avstånd till hus samt gas- och kraftledningar till undvika eventuell skada. Kontrollera området för elkablar och gasledningar. Fråga din lokala myndighet om ytterligare information om det behövs.

När du använder lämpliga värmare, håll ett avstånd på minst 1,2 m till presenningen material. Öppen eld eller värmare med öppen låga såsom uteplatsvärmare, paraply värmare, gasolvärmare etc. ska i alla fall INTE användas inne i tältet.

Den som har hand om byggandet av tältet ansvarar för adekvat säkra den för att garantera dess säkerhet. Vänligen kontrollera förankringen hela tiden för att undvika skada. En stabil förankring kan förlänga tältets uthållighet.

För att garantera din egen säkerhet, se till att bära handskar. Metalldelarna kan ha vassa kanter och kan vara oljiga på grund av rost förebyggande behandling.

Se till att det inte finns någon permanent snölast. Den bör tas bort genast. Detsamma gäller regn och andra former av belastning.

Varning - förvara plast och små reservdelar utom räckhåll för barn. De tunn hinna kan fästa vid näsa och mun och förhindra andning.

MONTERING OCH ANVÄNDNING

Vänligen reservera lite mer tid för din första installation av tältet. Reglerna som ska vara följs när du slår upp tältet är enkla. Använd de illustrativa instruktionerna för varje steg i installationen.

Skruvorna som förbinder rören med kopplingar måste dras åt manuellt med hjälp av en sexkantnyckel eller en automatisk skruvmejsel, inställd på max. nivå 2, för att undvika material bära.

Tältet bör endast monteras av minst två vuxna. Behåll barn bort från tältet medan du monterar det för att skydda dem.

Se till att hitta en plan och jämn markbas som är lämplig för montering av produkten och dess avsedda användning.

Använd endast det material som medföljer tältet vid leverans.

Preseningen får inte komma i kontakt med föremål med vassa kanter.

Tältet kan användas vid temperaturer nära noll. Men innan en sådan användning måste presenningsmaterialet förvaras vid en temperatur på minst 10 °C. Behåga se till att presenningen inte går sönder när den fälls ihop.

Varje land har olika regler gällande rörliga strukturer (tält) och orörliga strukturer. Fråga dina lokala myndigheter om ett tillstånd måste skaffas för att slå upp tältet. I vissa länder beror detta på storleken på tältet.

SKÖTSEL- OCH FÖRVARINGSINSTRUKTIONER

Någon form av skada på grund av naturhandlingar (väderskada) täcks inte.

Tältet kan användas vid temperaturer nära noll. Men innan en sådan användning måste presenningsmaterialet förvaras vid en temperatur på minst 10 °C. Behåga se till att presenningen inte går sönder när den fälls ihop.

Starka vindar kan skada produkten. Vänligen lämna inte lusthuset obebokat under en lång tid.

Exponering för solljus kan göra att presenningens färg bleknar. Detta har nej inverkan på eldstadens användbarhet och anses inte vara ett produktfel.

Kraftiga eller omfattande regn kan leda till ansamling av vattenfickor på taket. Dessa fickor måste tas bort så snart som möjligt.

Använd inte aggressiva kemikalier för att rengöra presenningsmaterialet. Det bästa rengöringsmedel är vatten med en lätt alkalisk reaktion.

Gör inga ändringar i tältets metallstruktur, t.ex till exempel att ansluta och/eller svetsa ytterligare belastningar, göra spår och/eller någon deformationer.

Ta bort presenningen om produkten inte används för att undvika skador.

Vi råder dig att demontera paviljongen under dåliga väderförhållanden och vintersäsongen.

Tältet/presenningen ska endast vikas, packas och förvaras när det är helt torrt. Snälla gör det

Lägg inte några andra föremål ovanpå tältet/presenningen när det förvaras.

SPECIFIKATIONER

Model	KD-TY007-1
Product Size	2970×3920×3530mm
Color	Beige/Brown/Black

VERKTYG

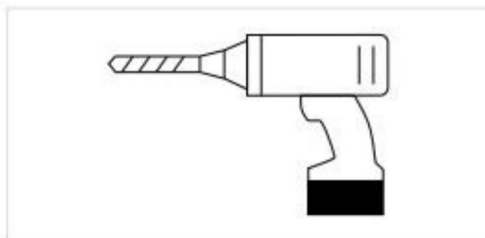





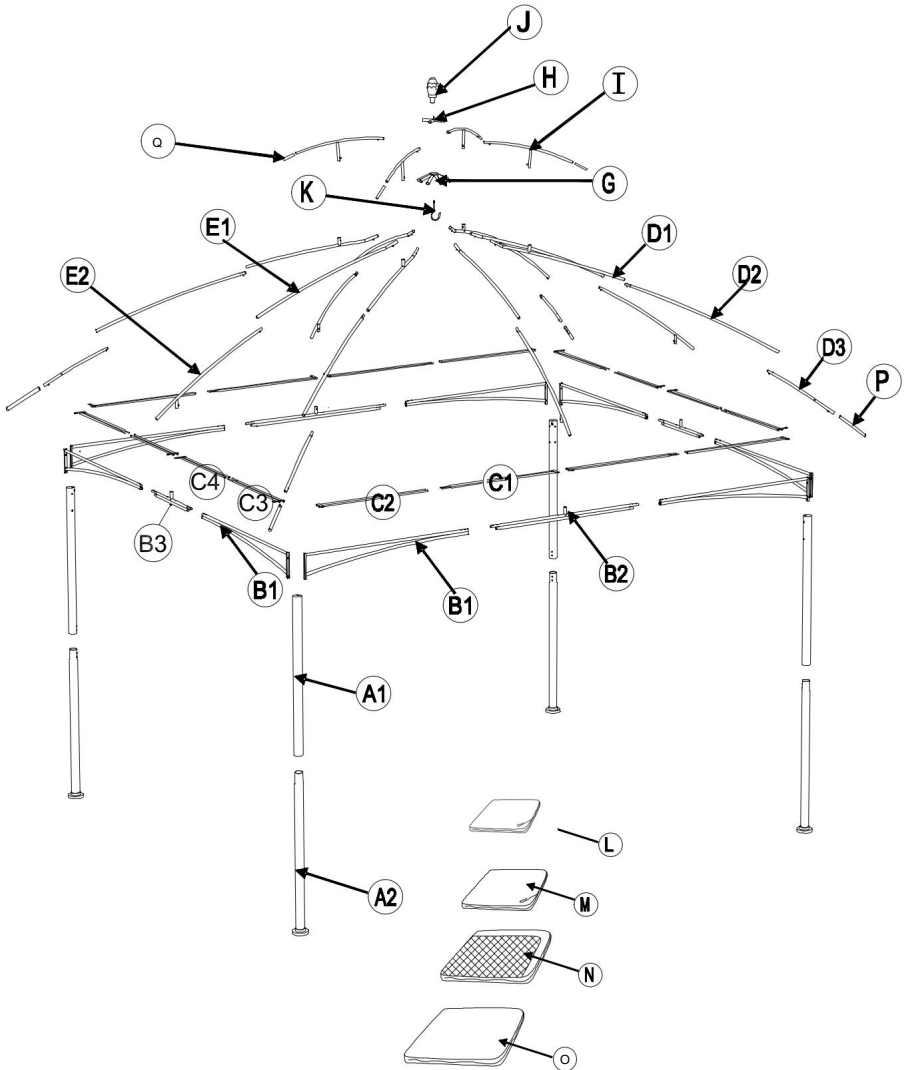
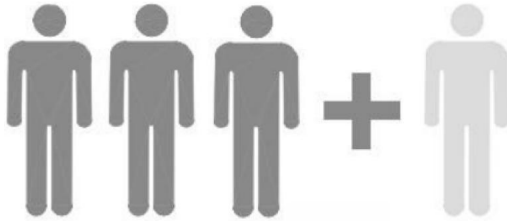





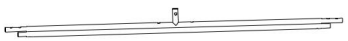
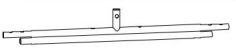













IMPORTANT





People needed for installation work

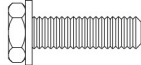
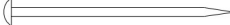

Parts List

Label	Qty	Part Image
A1	4	
A2	4	
B1	8	
B2	2	
B3	2	
C1	4	
C2	4	
C3	4	
C4	4	
D1	4	
D2	4	
D3	4	
E1	2	
E2	2	
F1	2	
F2	2	
G	1	
H	1	

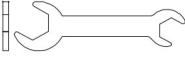
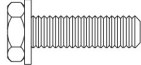
Parts list		
Label	Qty	Parts Image
I	4	
J	1	
K	1	
L	1	
M	1	
N	1	
P	4	
O	1	
Q	4	

Parts list				
Label	Description	Qty	Add	Parts Image
AA	M5*15	24	2	
BB	M6*20	40	2	
CC	Φ8*180	8	0	
DD	/	104	3	
EE	M5/M6	1	0	
FF	M6*35	4	1	
GG	M6	4	1	

1

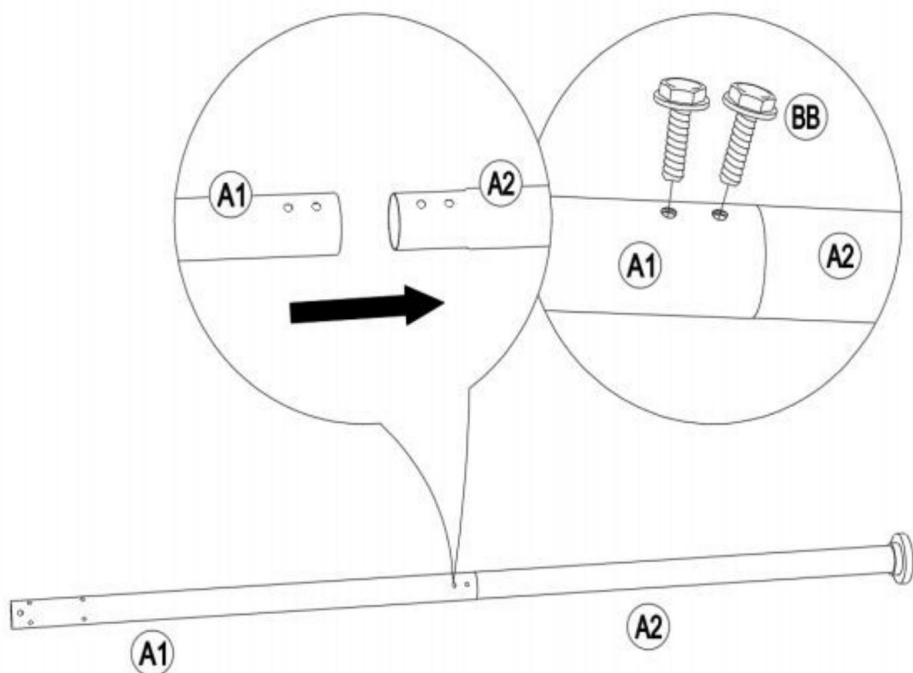
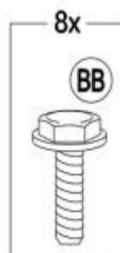
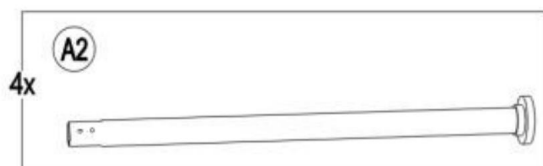

2

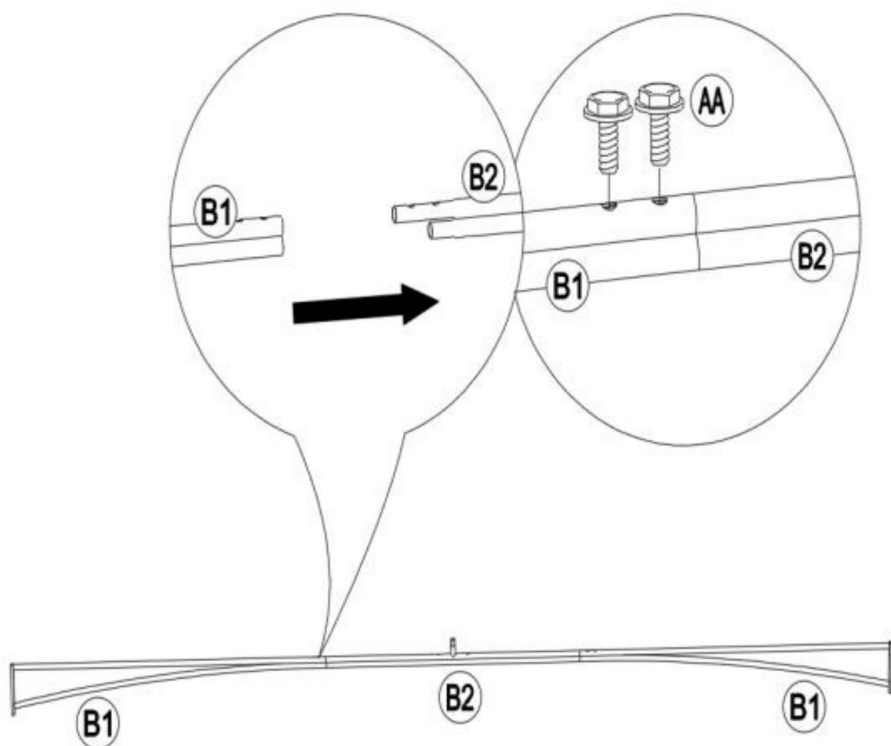
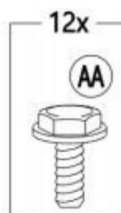
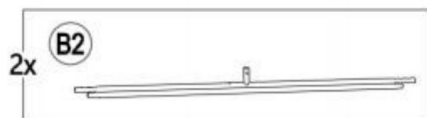
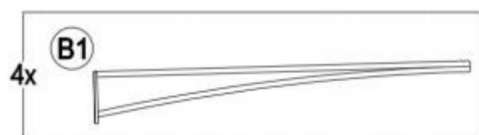

3

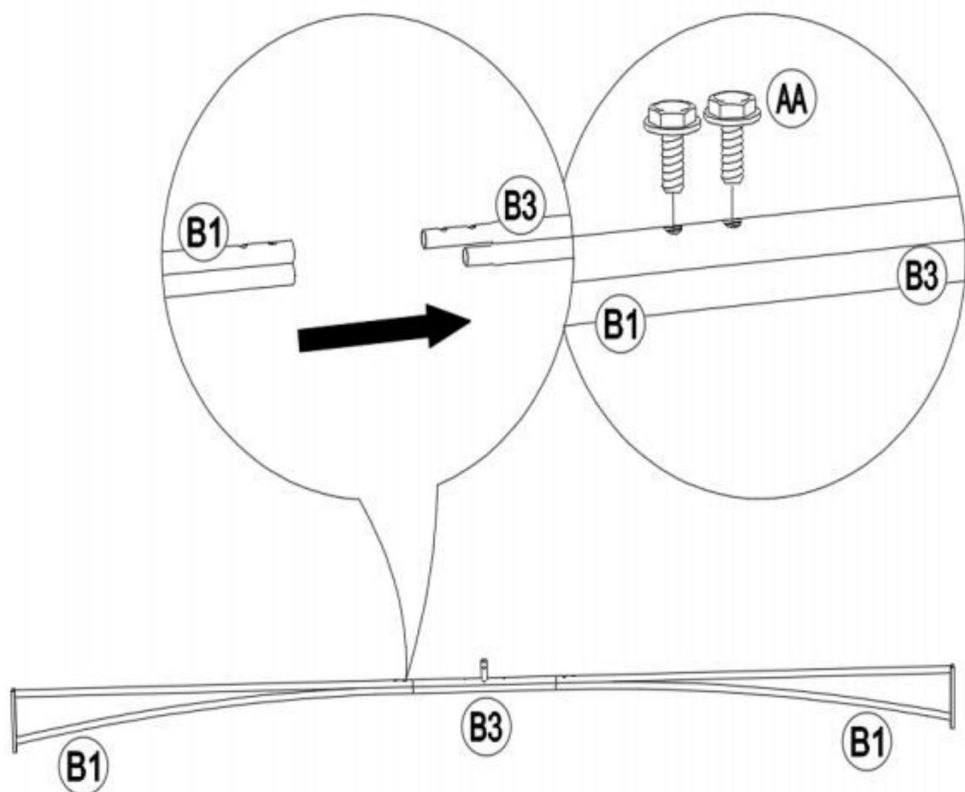
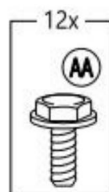
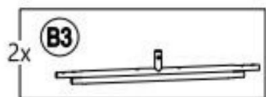
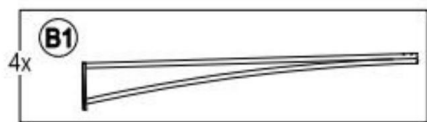

4

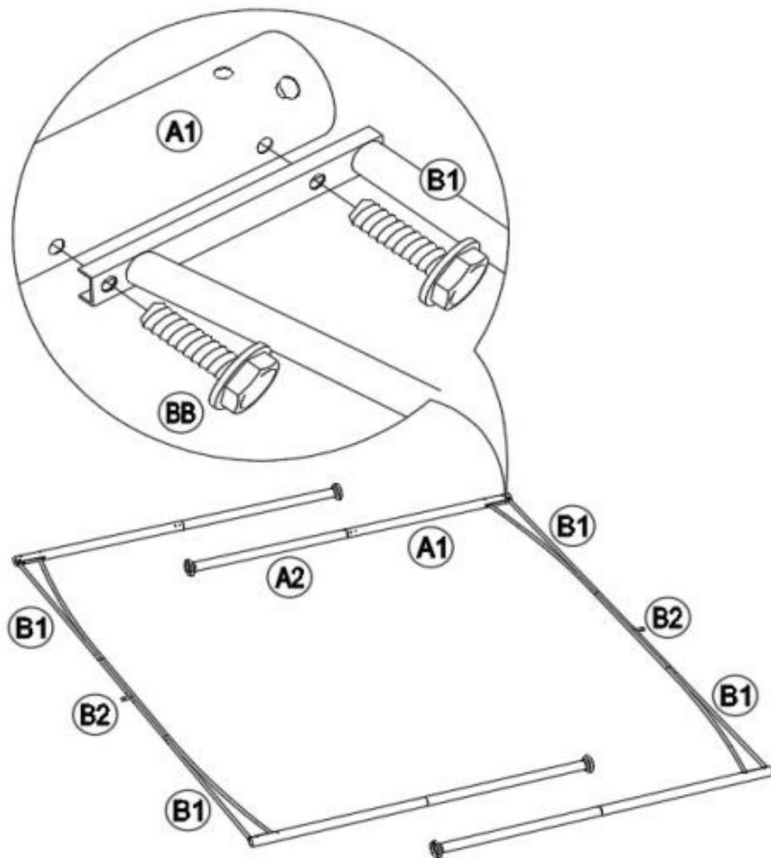
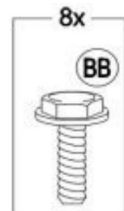
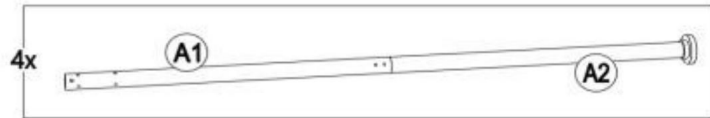
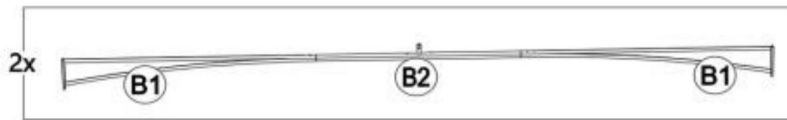

5

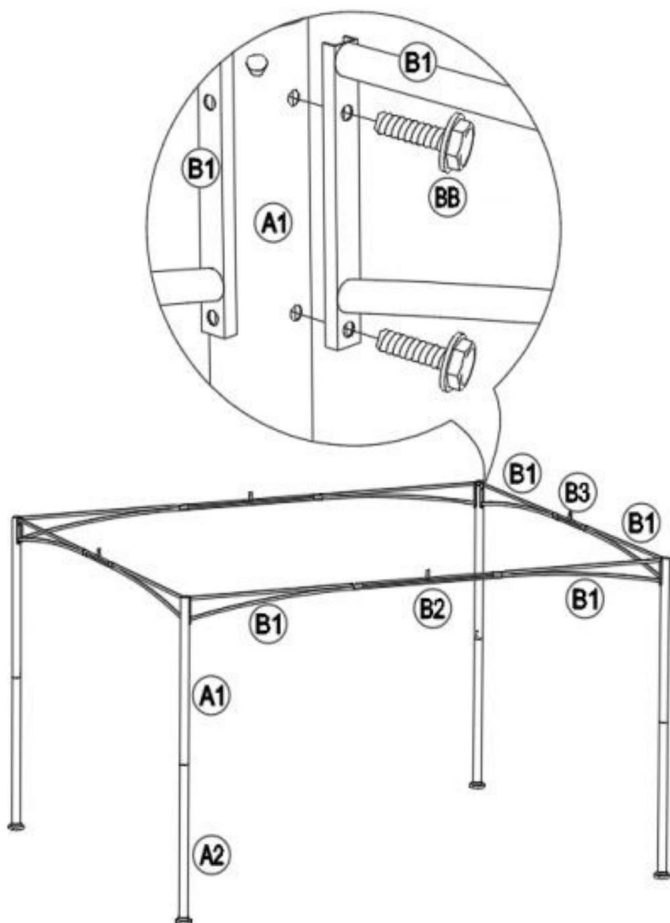
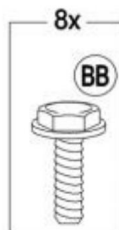
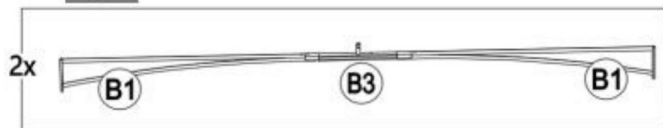

6

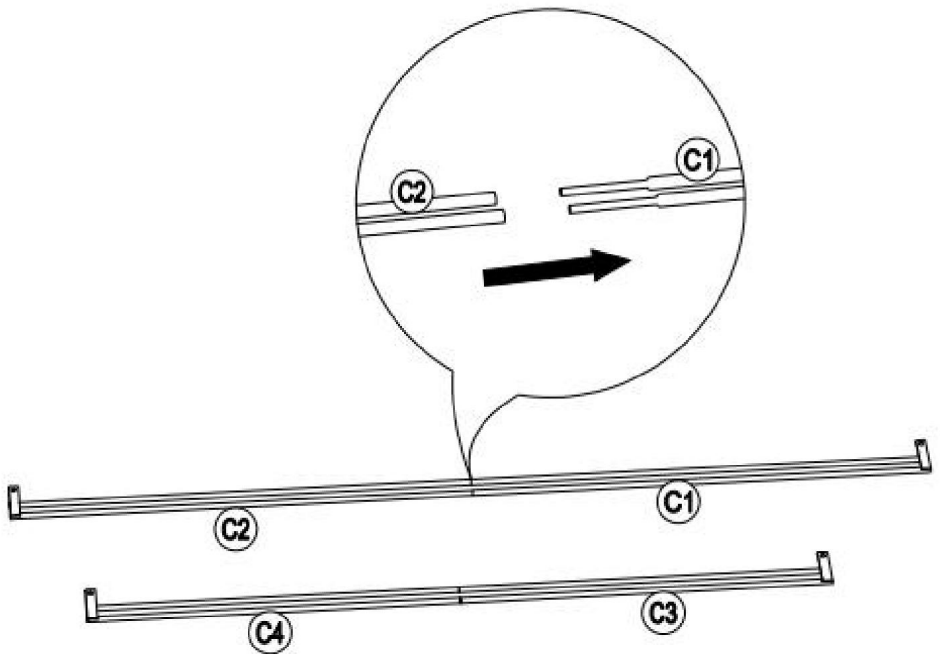
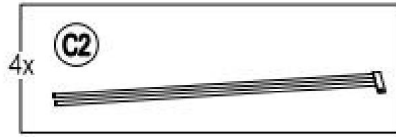
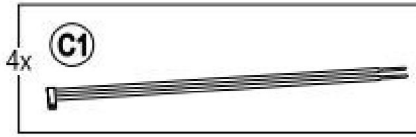

7

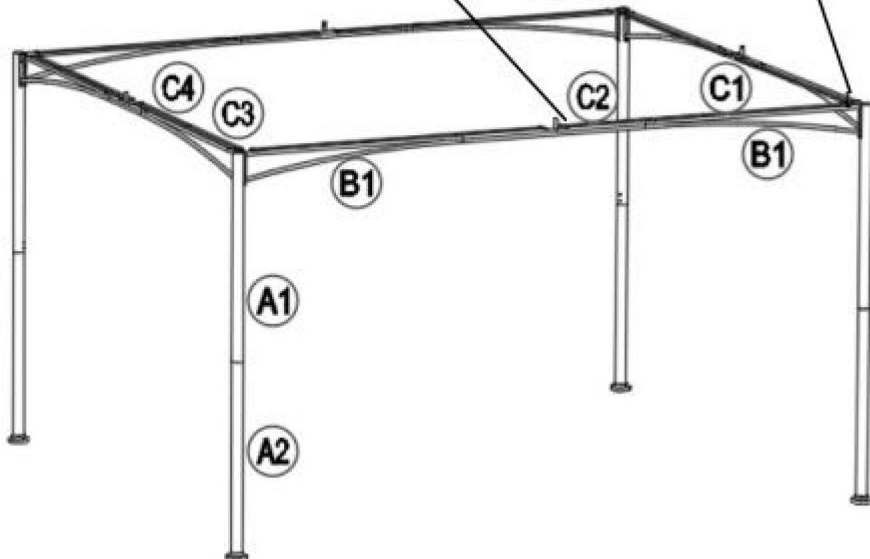
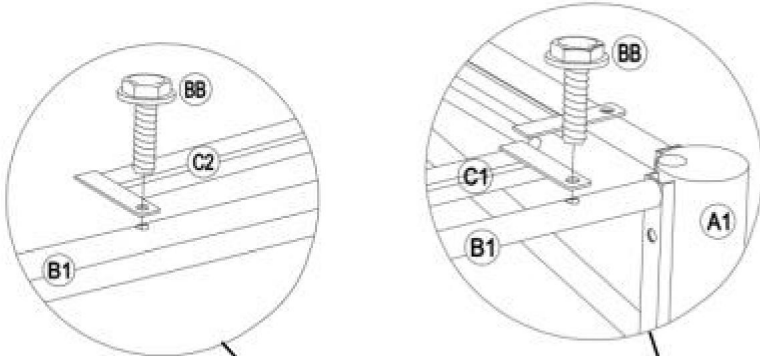
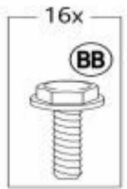

8

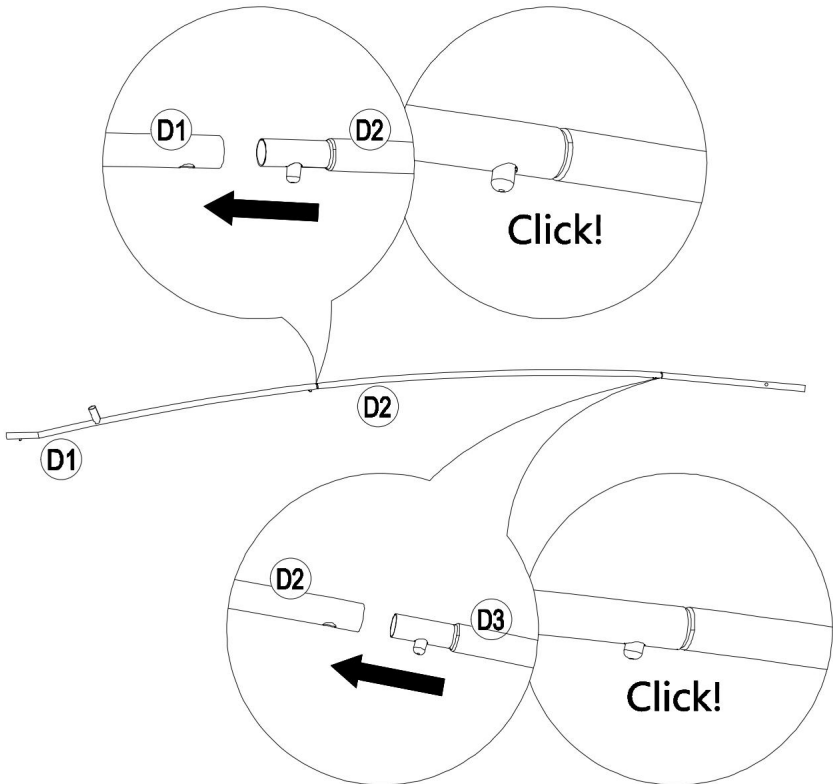
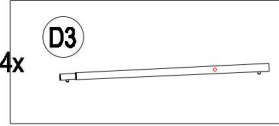
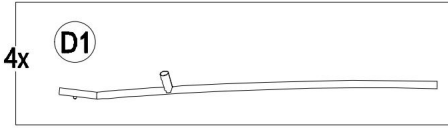

9

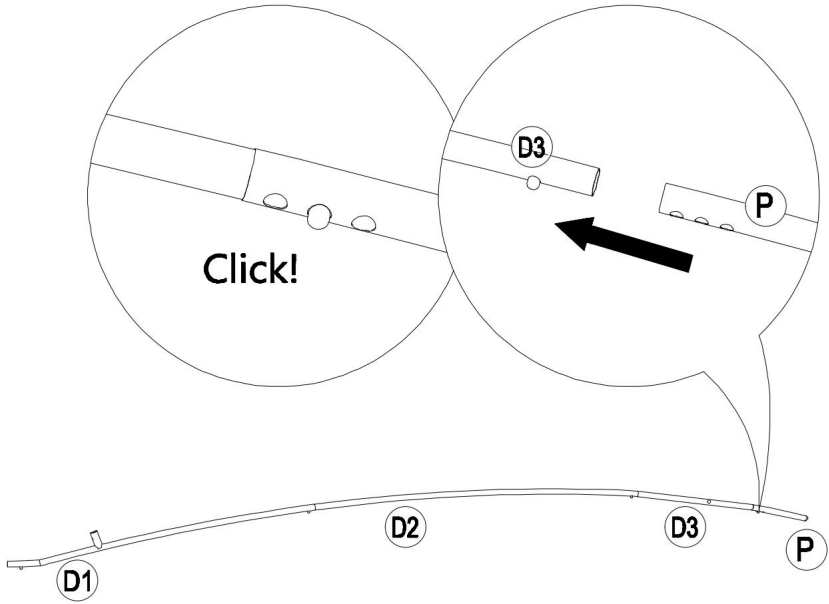
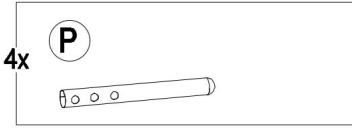

10

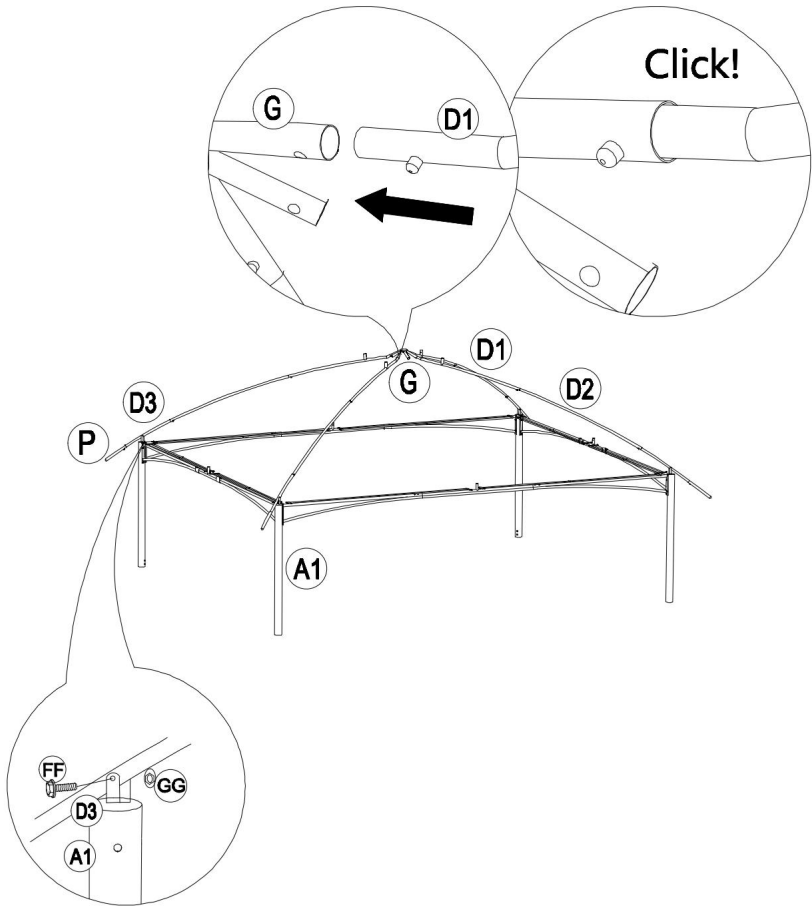
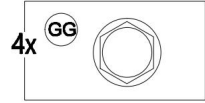
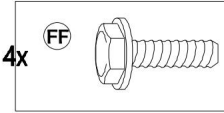
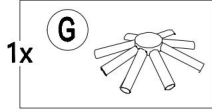
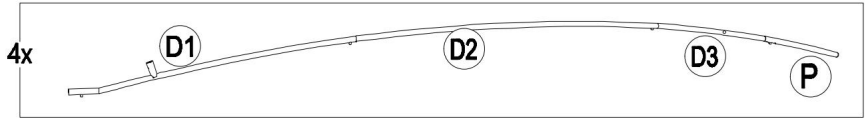

11

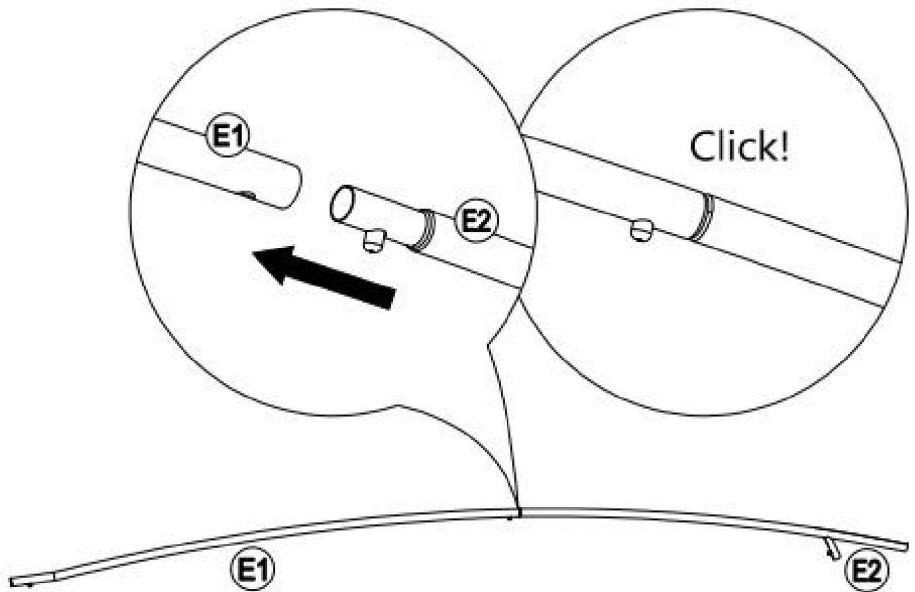

12

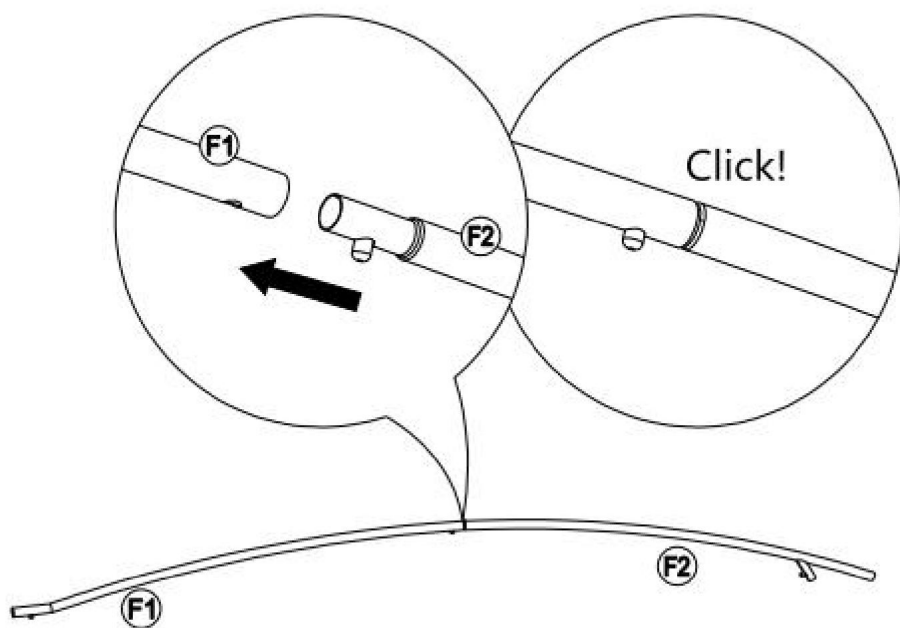
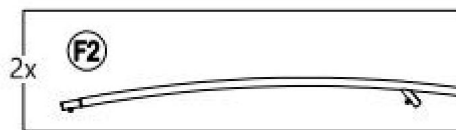
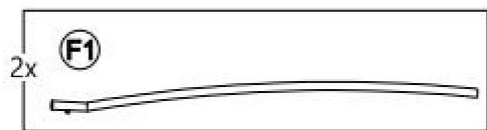

13

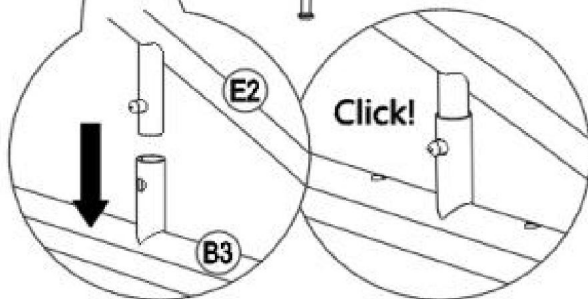
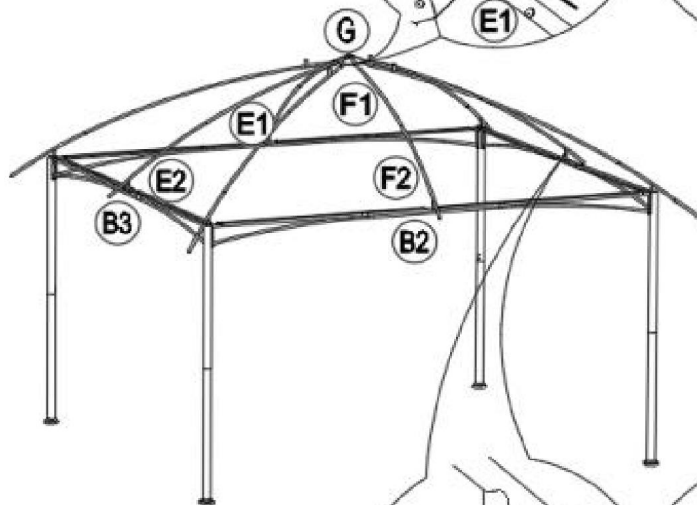
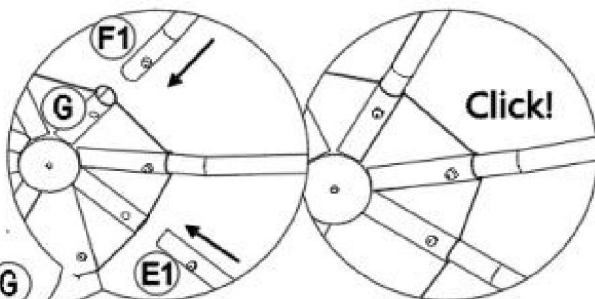
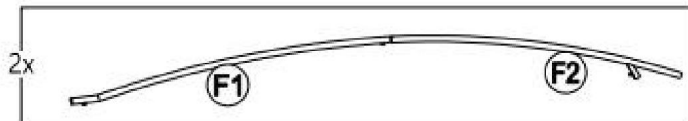
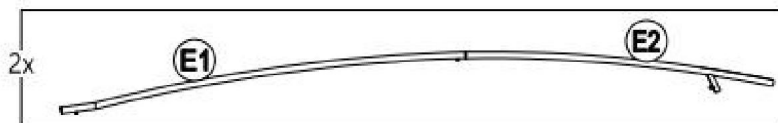

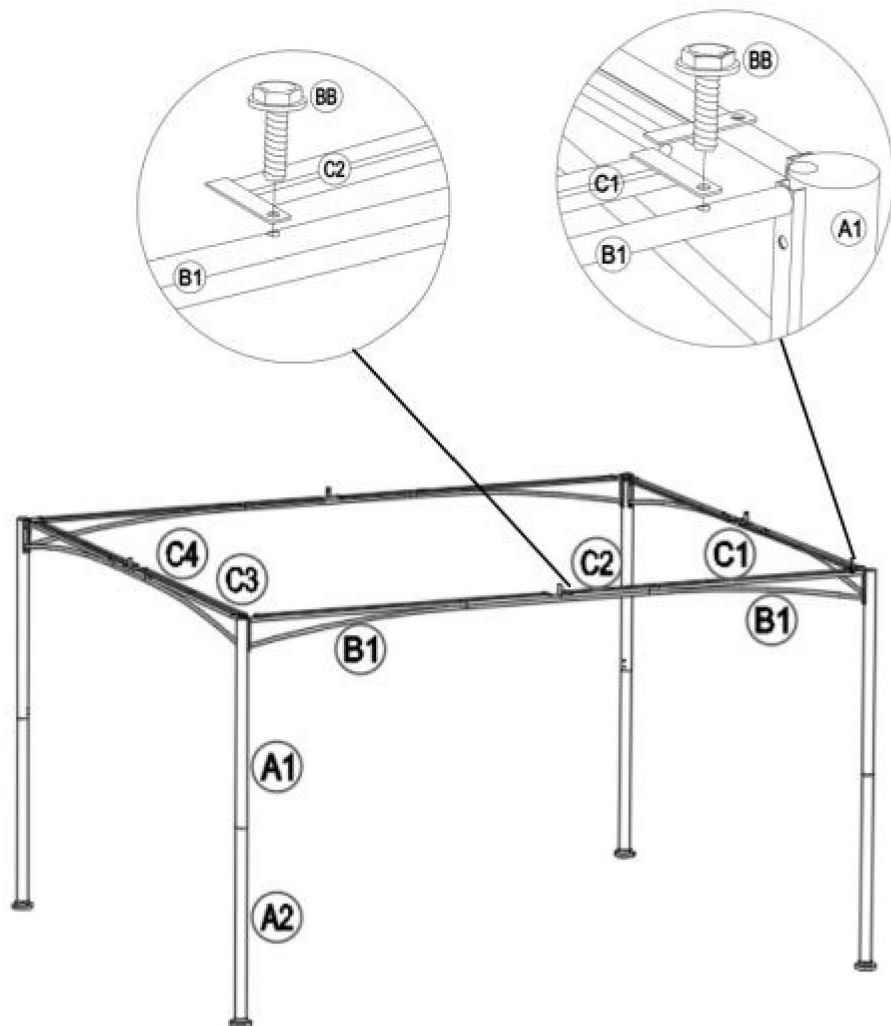

14

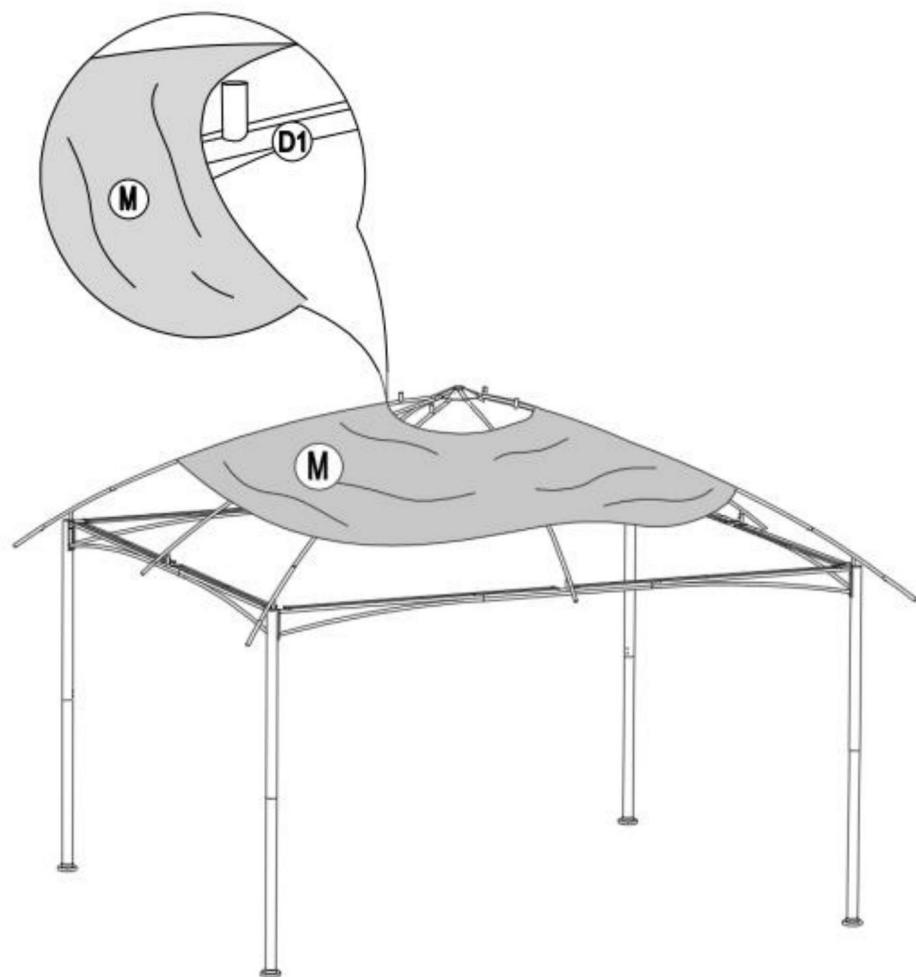
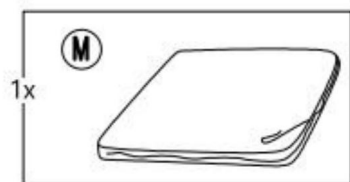

15

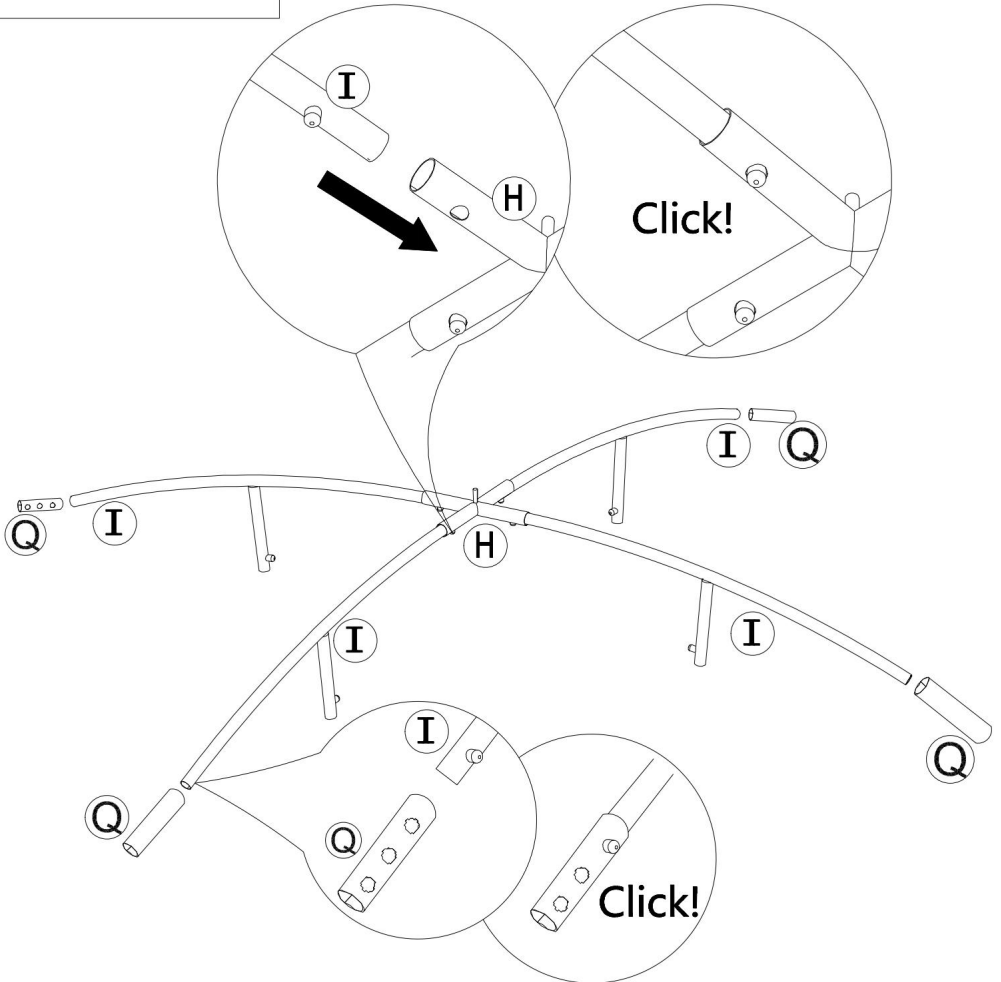
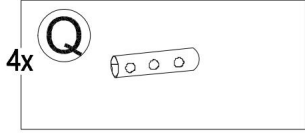
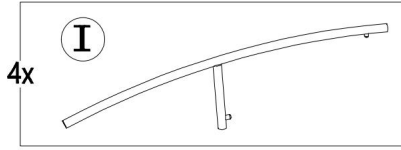
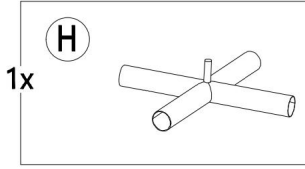

16

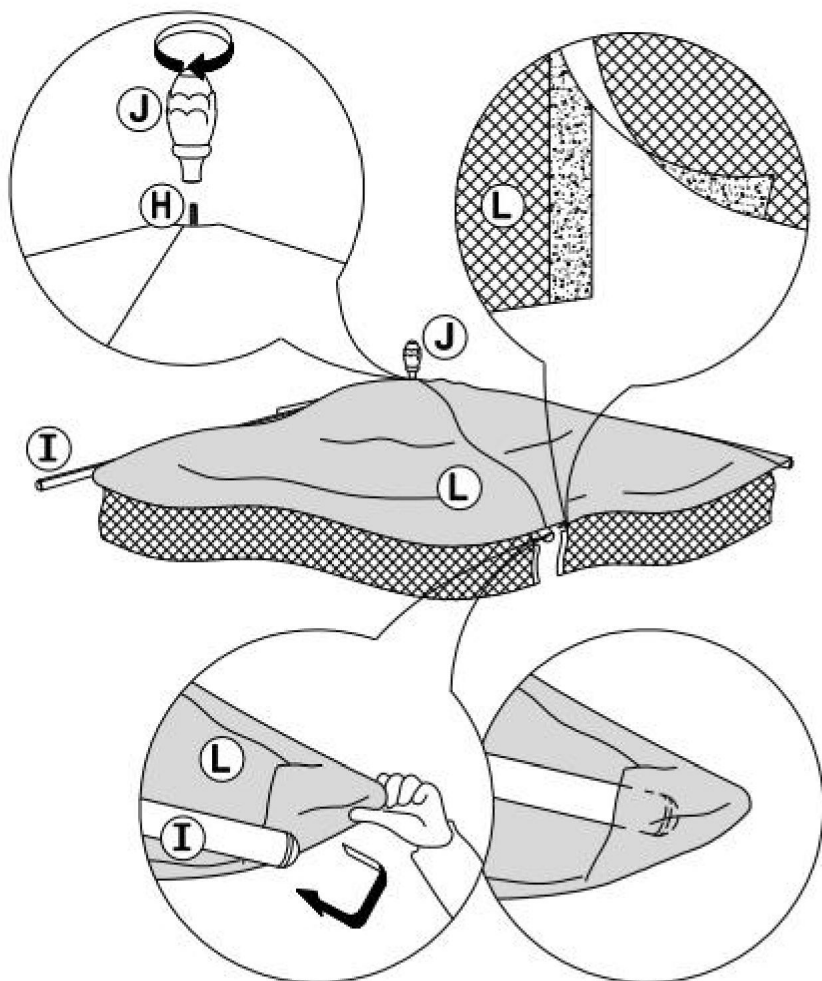
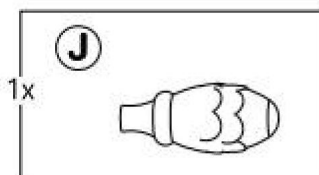
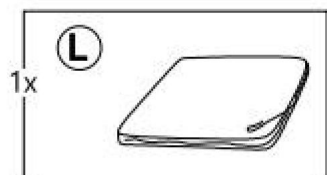

17

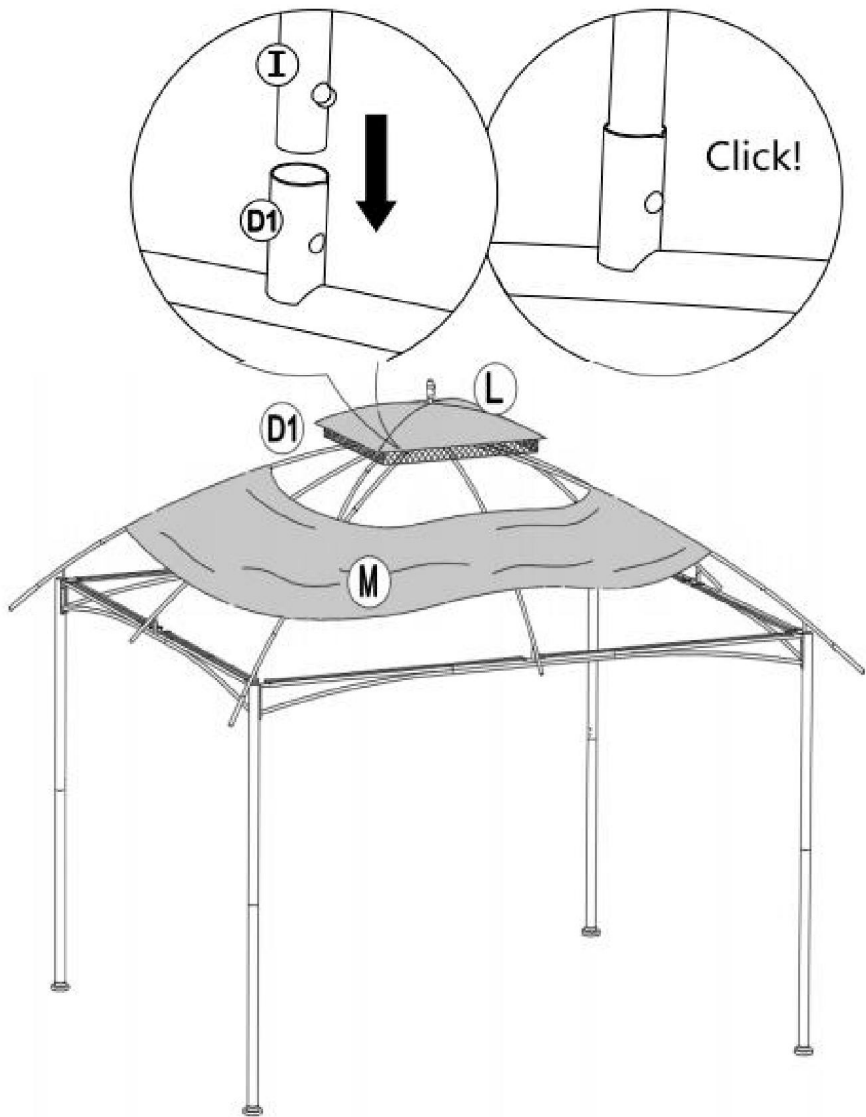

18

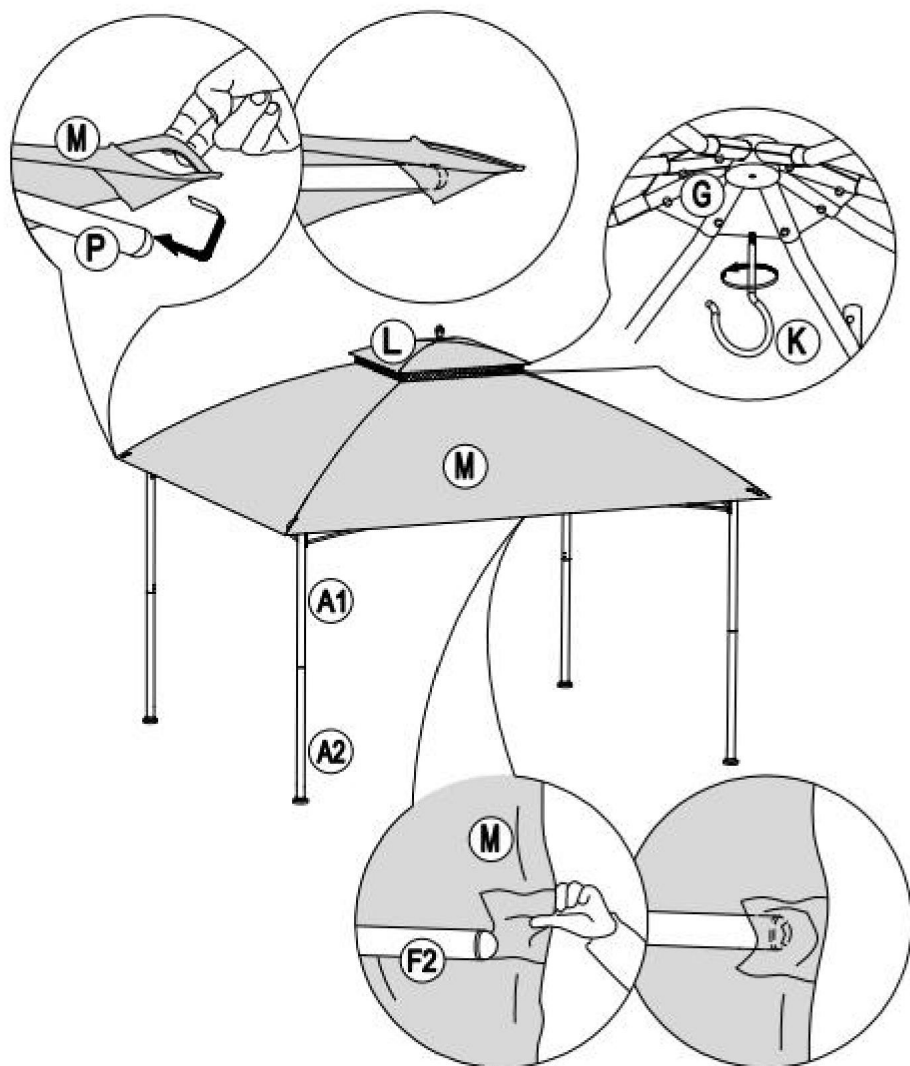
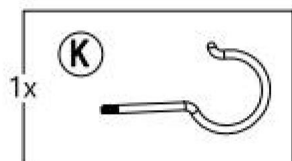

19

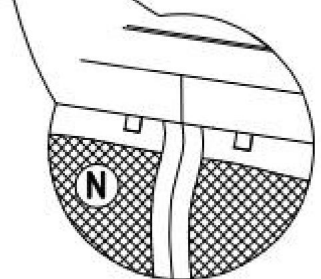
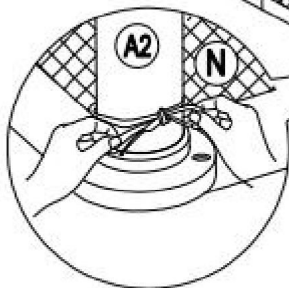
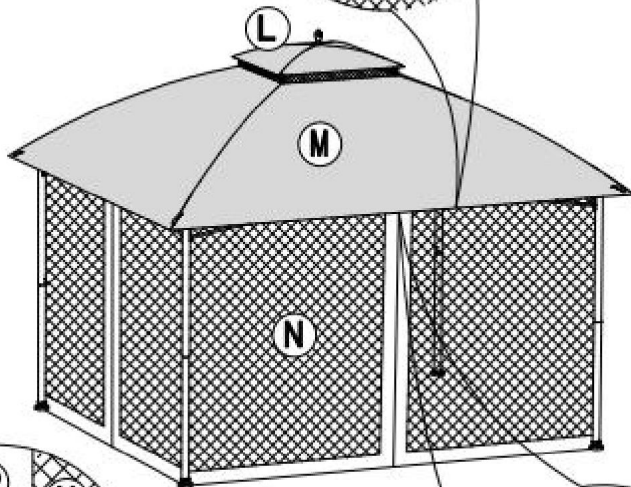
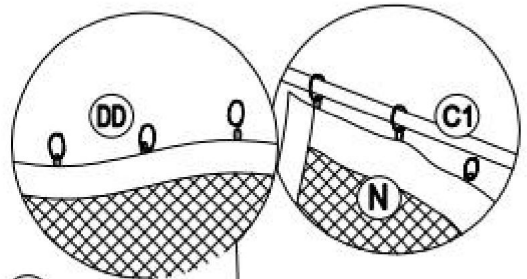
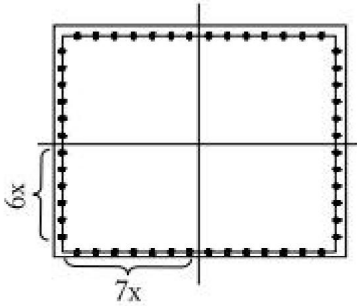
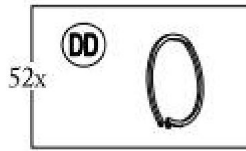
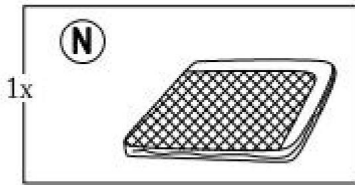

20

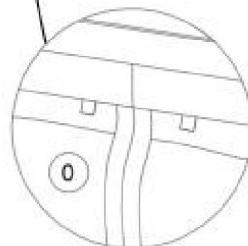
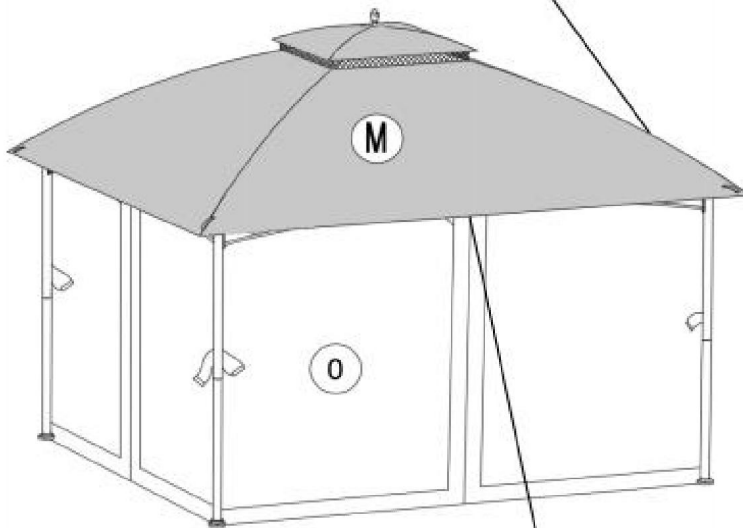
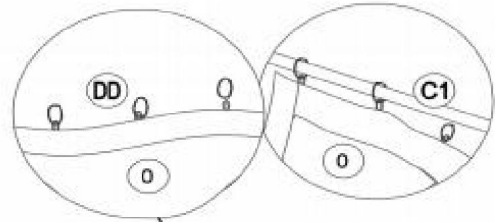
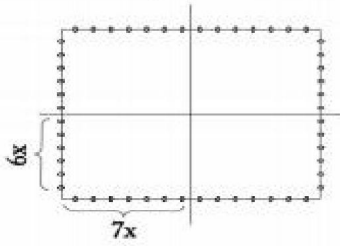
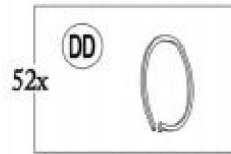
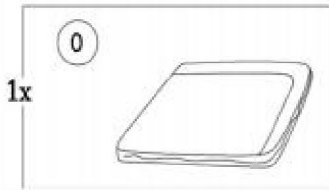

21

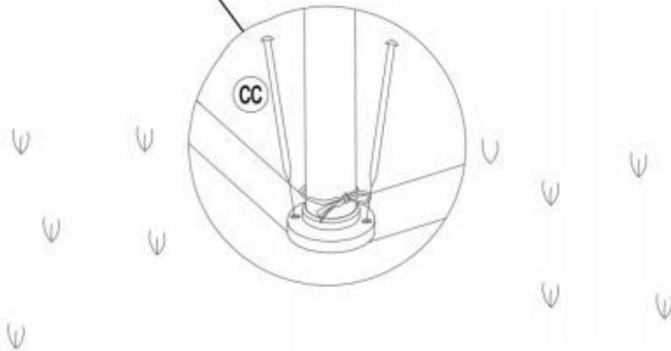
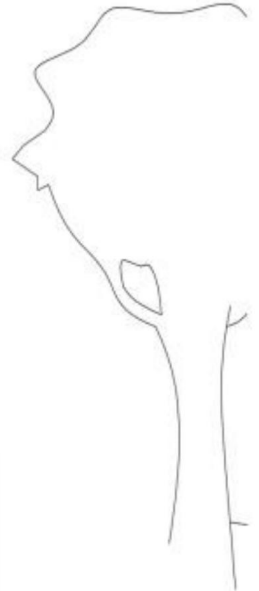
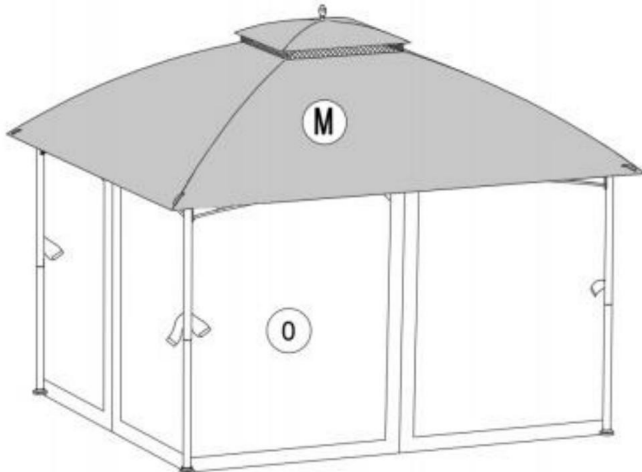

Importerad till USA: Sanven Technology Ltd.
Suite 250, 9166 Anaheim Place, Rancho Cucamonga, CA 91730

VEVOR®

TOUGH TOOLS, HALF PRICE

Teknisk support och e-garanticertifikat

www.vevor.com/support

VEVOR[®]

TOUGH TOOLS, HALF PRICE

Soporte técnico y certificado de garantía electrónica www.vevor.com/support

INSTRUCCIONES PARA GAZEBOS DE PATIO

MODELO:KD-TY007-1

Seguimos comprometidos a brindarle herramientas a precios competitivos.

"Ahorre la mitad", "mitad de precio" o cualquier otra expresión similar que utilicemos solo representa una estimación del ahorro que podría obtener al comprar ciertas herramientas con nosotros en comparación con las principales marcas y no necesariamente significa que cubra todas las categorías de herramientas que ofrecemos. Le recordamos que, al realizar un pedido con nosotros, verifique cuidadosamente si realmente está ahorrando la mitad en comparación con las principales marcas.

VEVOR[®]

TOUGH TOOLS, HALF PRICE

GAZEBOS PARA PATIOS

KD-TY007-1

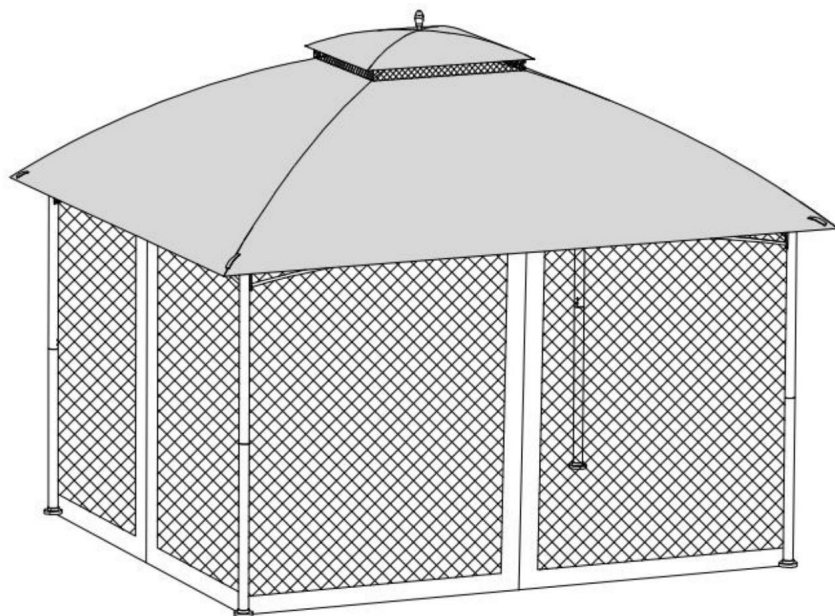

¿NECESITA AYUDA? ¡CONTÁCTENOS!

¿Tiene preguntas sobre el producto? ¿Necesita asistencia técnica? No dude en ponerse en contacto con nosotros:

Soporte técnico y certificado de garantía electrónica www.vevor.com/support

Estas son las instrucciones originales, lea atentamente todas las instrucciones del manual antes de utilizar el producto. VEVOR se reserva una interpretación clara de nuestro manual de usuario. La apariencia del producto estará sujeta al producto que recibió. Perdónenos por no informarle nuevamente si hay actualizaciones de tecnología o software en nuestro producto.

INSTRUCCIONES DE MONTAJE Y SEGURIDAD

Preste mucha atención a las siguientes instrucciones para reducir el riesgo de lesiones, accidentes o daños al producto en sí.

IMPORTANTE

Siga TODAS las instrucciones de seguridad enumeradas a continuación.

Retire el material de embalaje antes de ensamblar o utilizar el producto.

Asegúrese de que todas las piezas enumeradas estén incluidas en el paquete y que estén No dañado.

Lea atentamente estas instrucciones de montaje y seguridad antes de utilizar el tienda y guárdela para futuras referencias.

Este producto sólo debe utilizarse de forma no comercial.

INFORMACIÓN DE SEGURIDAD

La tienda no fue probada para cargas de viento y nieve, a menos que se indique claramente De lo contrario, estas cargas no están cubiertas por la garantía. Por favor, observe las previsiones meteorológicas para poder proteger o desmontar adecuadamente la tienda antes Aparecen problemas.

Las tiendas de campaña sólo deben utilizarse como alojamiento temporal y deben desmontado en condiciones climáticas adversas.

Asegúrese de mantener una distancia suficiente con las casas, así como con las líneas de gas y electricidad. Evite posibles daños. Compruebe que no haya cables eléctricos ni tuberías de gas en la zona. Pregunte a su autoridad local para obtener más información si necesita más información.

Al utilizar calentadores adecuados, mantenga una distancia mínima de 1,2 m con respecto a la lona. material. Fuego abierto o calentadores con llamas abiertas como calentadores de patio, sombrillas No se deben utilizar en ningún caso calentadores, calefactores a gas, etc. dentro de la tienda.

La persona encargada de la construcción de la carpa es responsable de su instalación adecuada. asegurarlo para garantizar su seguridad. Por favor, revise el anclaje constantemente para evitar Daños. Un anclaje estable puede prolongar la resistencia de la tienda.

Para garantizar su propia seguridad, asegúrese de usar guantes.

Las partes metálicas podrían tener bordes afilados y podrían estar aceitosas debido al óxido. tratamiento de prevención.

Asegúrese de que no haya una carga de nieve permanente. Debe eliminarse. inmediatamente. Lo mismo se aplica a la lluvia y otras formas de carga.

Advertencia: mantenga el plástico y las piezas de repuesto pequeñas fuera del alcance de los niños. Una película fina puede adherirse a la nariz y la boca e impedir la respiración.

MONTAJE Y USO

Reserve algo de tiempo adicional para la primera instalación de la carpa. Las reglas a seguir Los pasos a seguir para montar la tienda son sencillos. Utilice las instrucciones ilustrativas para cada paso de la instalación.

Los tornillos que unen las tuberías con los conectores deben apretarse manualmente, utilizando un Llave hexagonal o destornillador automático, ajustado a un nivel máximo de 2, para evitar daños en el material.

tener puesto.

La carpa debe ser montada por al menos dos adultos. Mantenga a los niños lejos de la tienda mientras la montaban para protegerlos.

Asegúrese de encontrar una base plana y uniforme que sea adecuada para el montaje del producto y su uso previsto.

Utilice únicamente los materiales proporcionados con la tienda en el momento de la entrega.

Las lonas no deben entrar en contacto con ningún objeto con bordes afilados.

La tienda se puede utilizar en temperaturas cercanas a cero grados. Sin embargo, antes de que se alcancen estos valores, Para su uso, el material de lona debe almacenarse a una temperatura de al menos 10 . Asegúrese de que la lona no se rompa al doblarla.

Cada país tiene diferentes regulaciones con respecto a las estructuras móviles (carpas) y estructuras inamovibles. Pregunte a las autoridades locales si se ha concedido un permiso

Para montar la tienda de campaña es necesario obtener un certificado de aptitud física. En algunos países, esto depende del tamaño de la tienda.

La tienda de campaña.

INSTRUCCIONES DE CUIDADO Y ALMACENAMIENTO

No se cubren ningún tipo de daños debidos a fenómenos naturales (daños climáticos).

La tienda se puede utilizar en temperaturas cercanas a cero grados. Sin embargo, antes de que se alcancen estos valores, Para su uso, el material de lona debe almacenarse a una temperatura de al menos 10 . Asegúrese de que la lona no se rompa al doblarla.

Los vientos fuertes pueden dañar el producto. No abandone el cenador. desatendido durante un largo periodo de tiempo.

La exposición a la luz solar puede hacer que el color de la lona se desvanezca. Esto no tiene ningún efecto. afecta la usabilidad del brasero y no se considera un defecto del producto.

Las lluvias intensas o prolongadas pueden provocar la acumulación de bolsas de agua en el techo. Estos bolsillos deben eliminarse lo antes posible.

No utilice productos químicos agresivos para limpiar el material de la lona. Lo mejor El agente limpiador es agua con una reacción ligeramente alcalina.

No realice ninguna modificación en la estructura metálica de la tienda, como por ejemplo: Por ejemplo, conectar y/o soldar cargas adicionales, realizar ranuras y/o cualquier deformaciones.

Retire la lona si el producto no está en uso para evitar daños.

Le recomendamos desmontar el pabellón en caso de malas condiciones meteorológicas y Temporada de invierno.

La carpa o lona solo debe doblarse, empaquetarse y almacenarse cuando esté completamente seca. No coloque ningún otro objeto encima de la tienda/lona cuando esté guardada.

PRESUPUESTO

Model	KD-TY007-1
Product Size	2970×3920×3530mm
Color	Beige/Brown/Black

HERRAMIENTAS

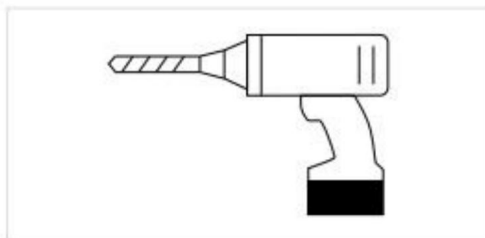





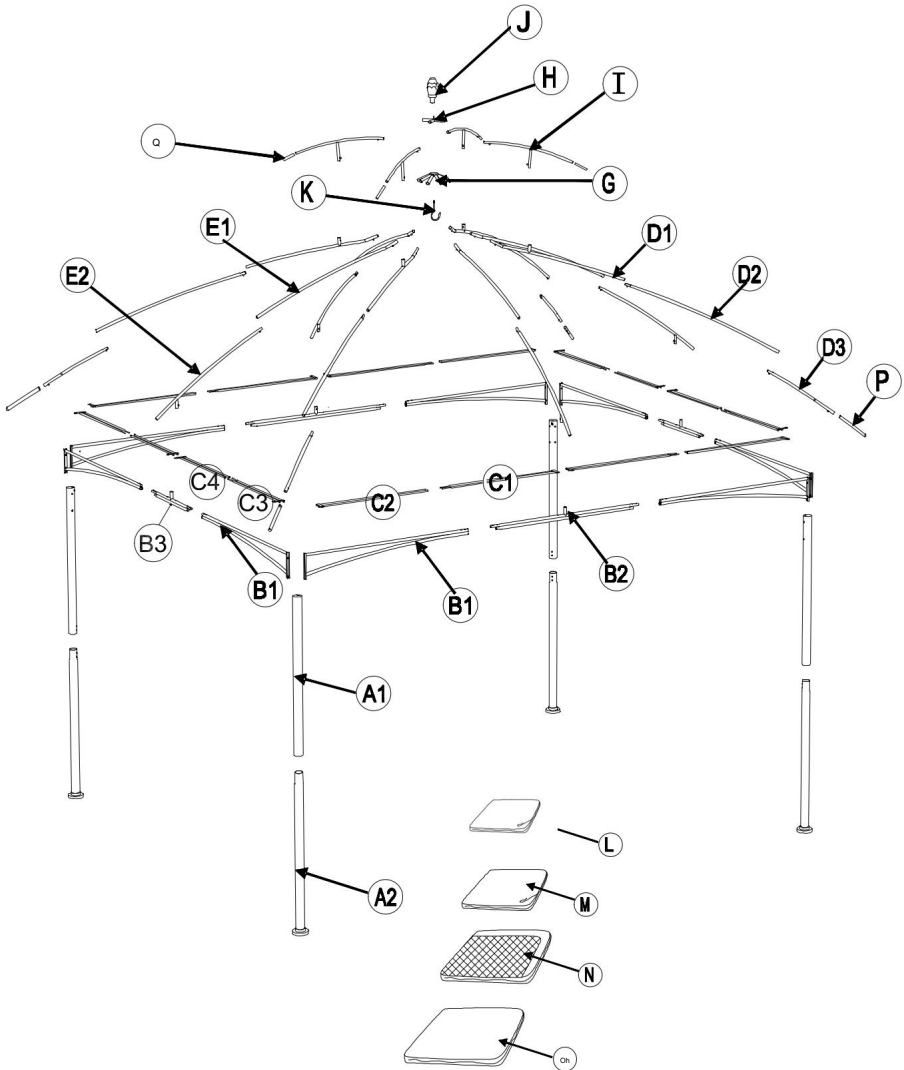
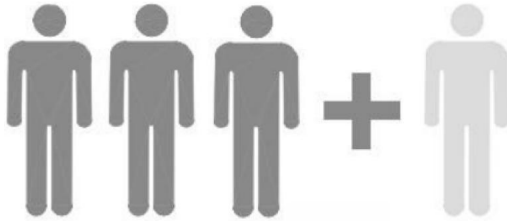



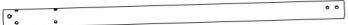

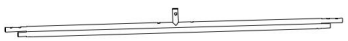
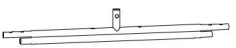













IMPORTANT





People needed for installation work

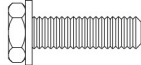
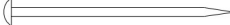

Parts List

Label	Qty	Part Image
A1	4	
A2	4	
B1	8	
B2	2	
B3	2	
C1	4	
C2	4	
C3	4	
C4	4	
D1	4	
D2	4	
D3	4	
E1	2	
E2	2	
F1	2	
F2	2	
G	1	
H	1	

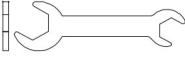
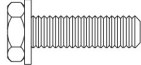
Parts list		
Label	Qty	Parts Image
I	4	
J	1	
K	1	
L	1	
M	1	
N	1	
P	4	
O	1	
Q	4	

Parts list				
Label	Description	Qty	Add	Parts Image
AA	M5*15	24	2	
BB	M6*20	40	2	
CC	Φ8*180	8	0	
DD	/	104	3	
EE	M5/M6	1	0	
FF	M6*35	4	1	
GG	M6	4	1	

1

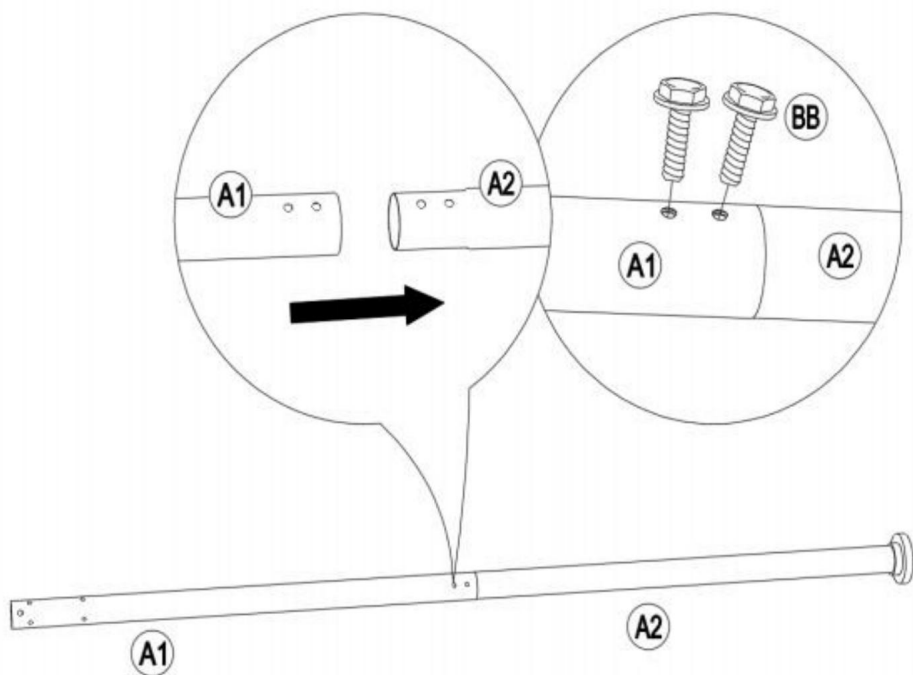
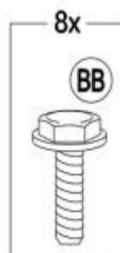
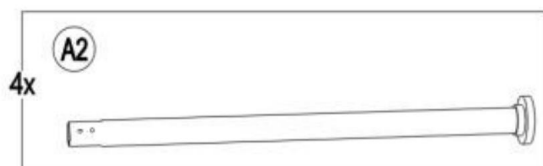

2

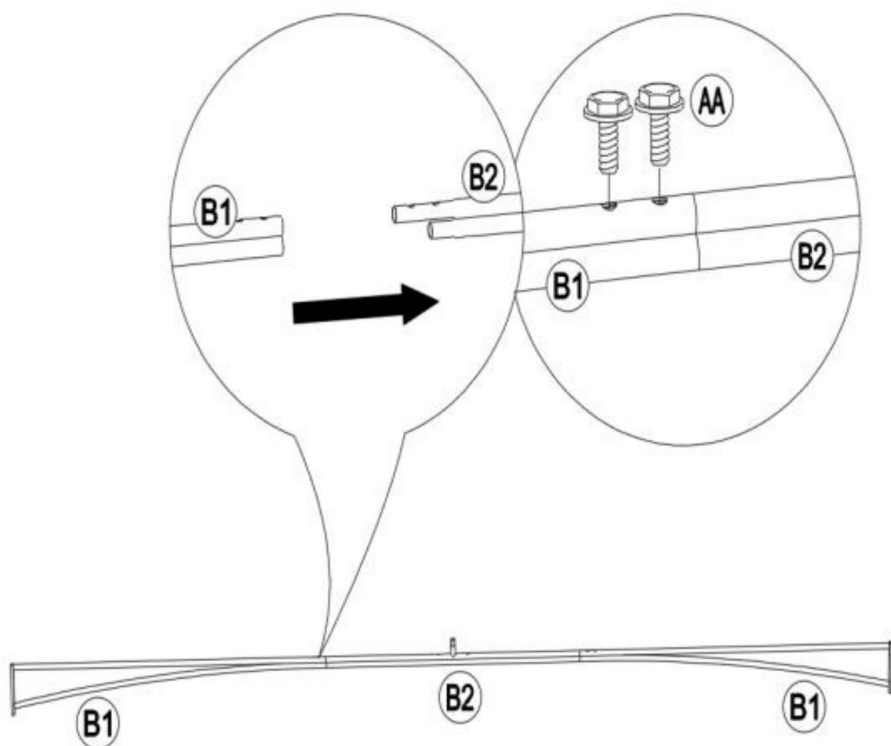
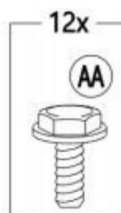
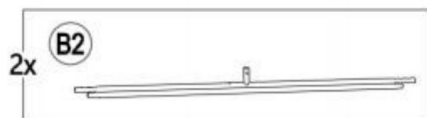
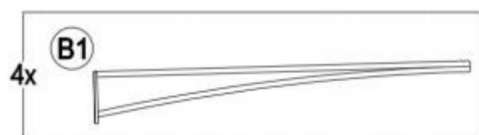

3

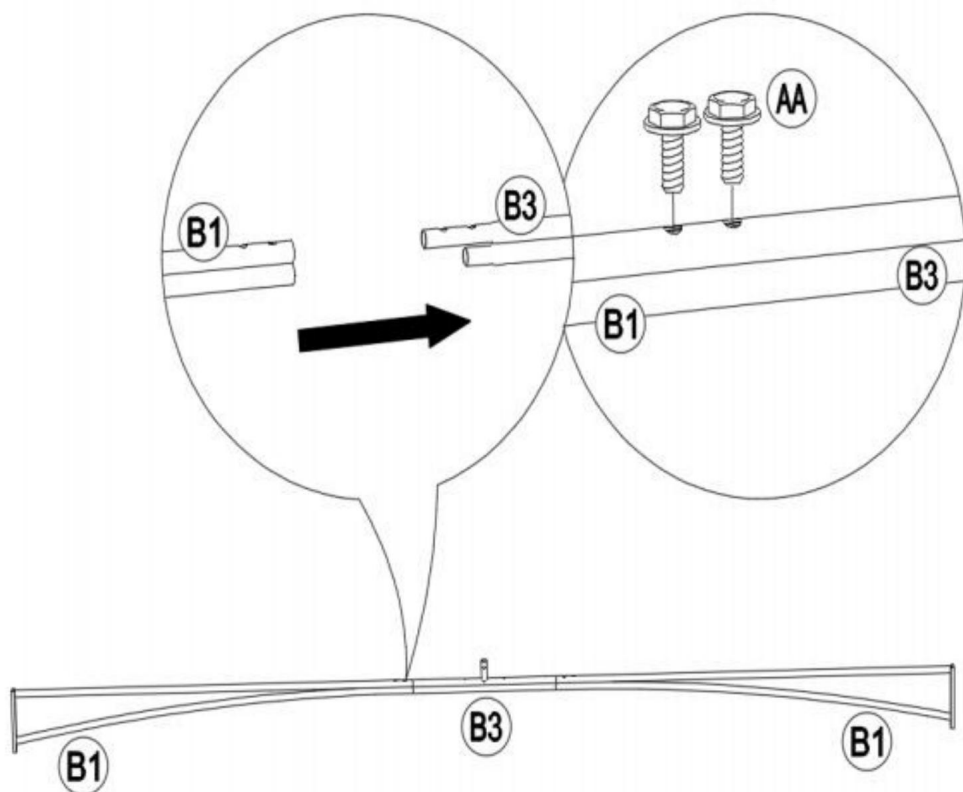
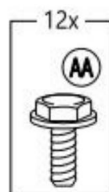
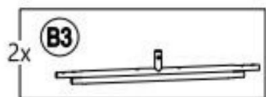
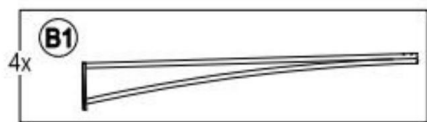

4

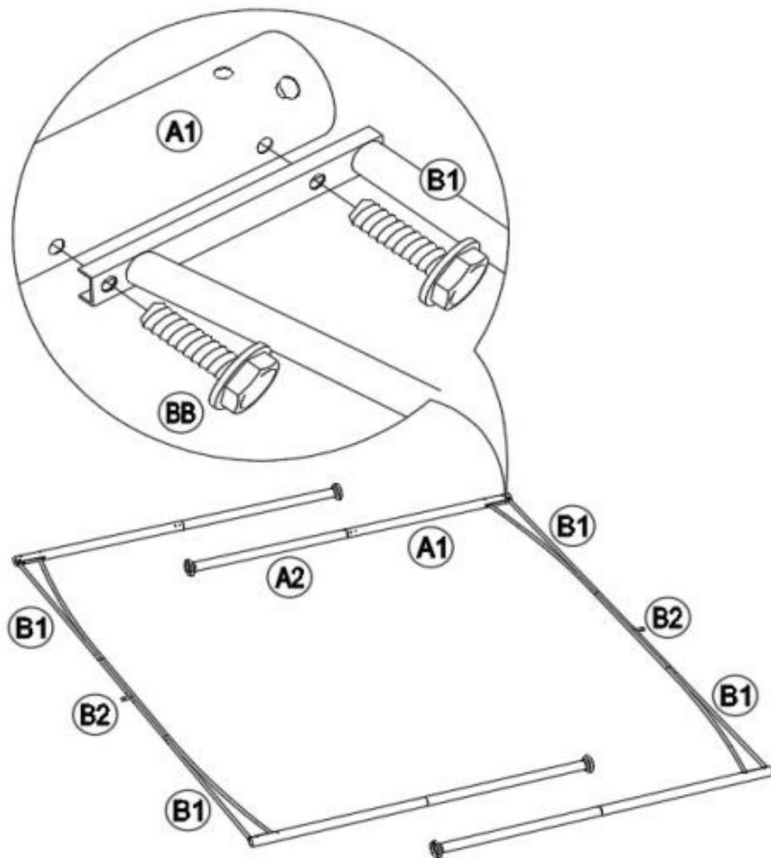
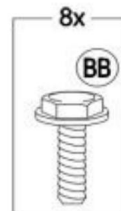
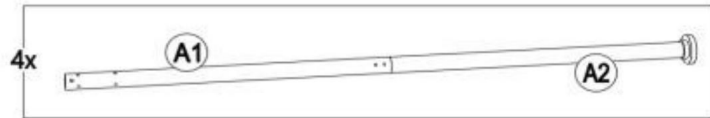
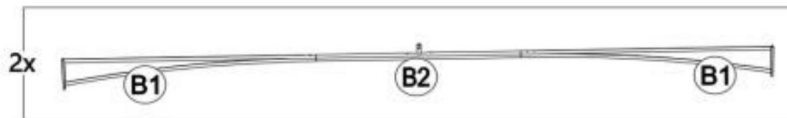

5

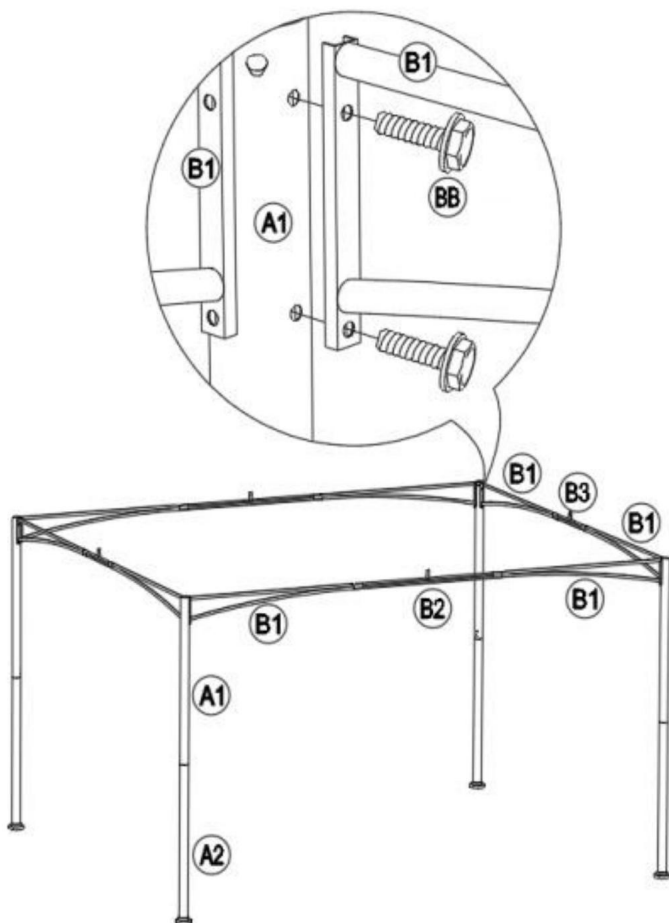
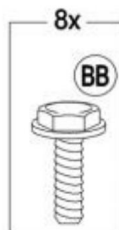
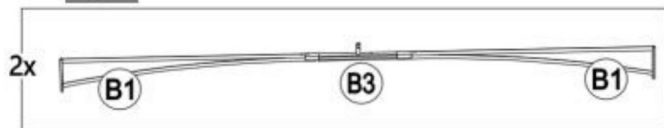

6

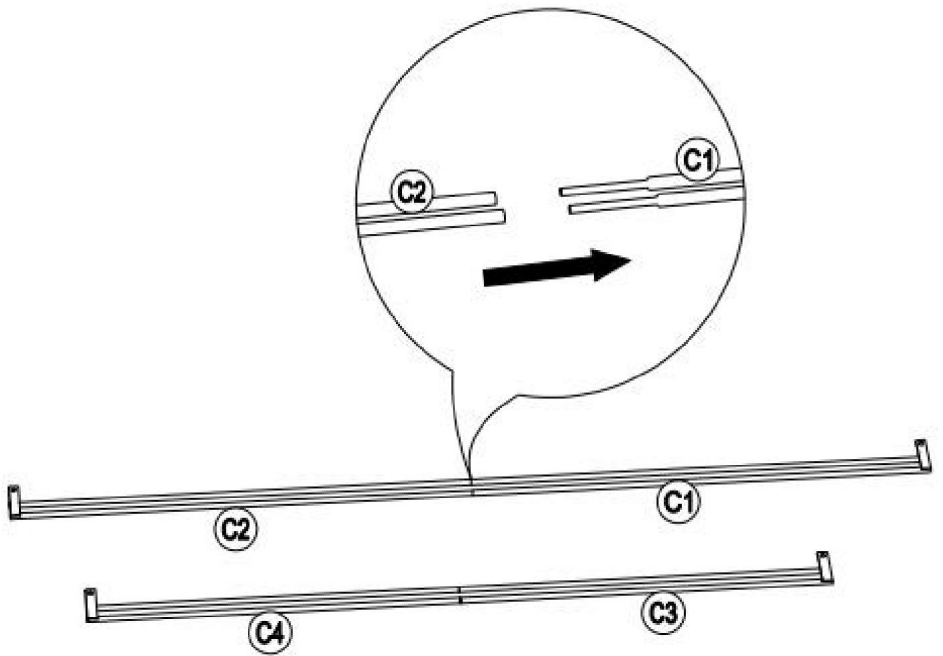
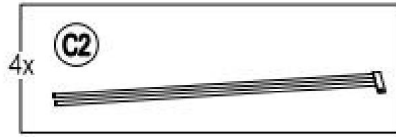
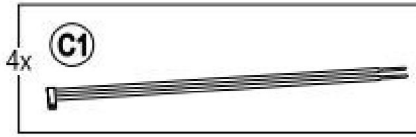

7

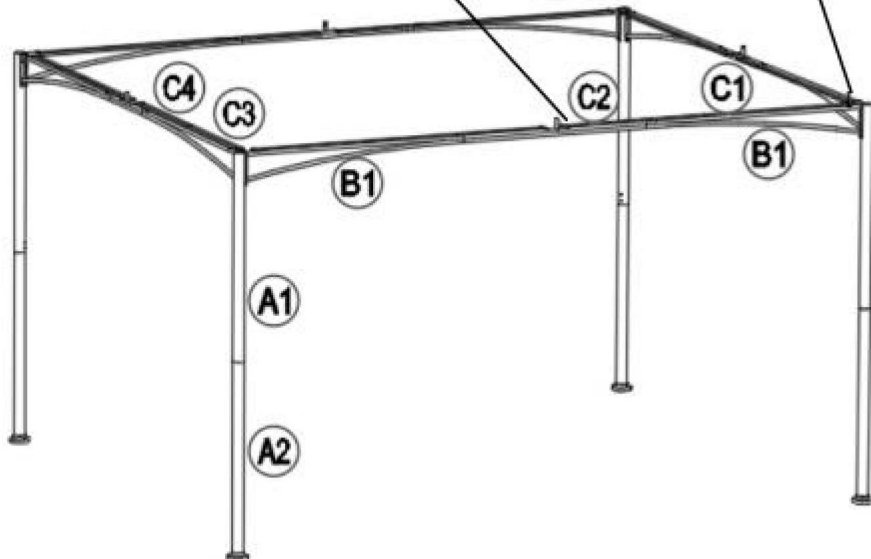
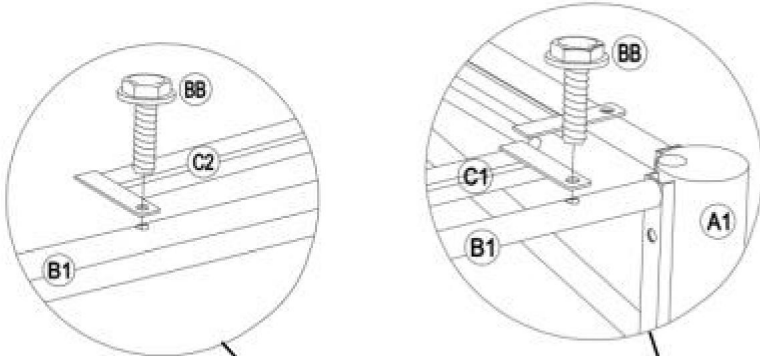
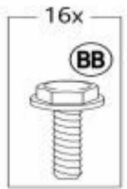

8

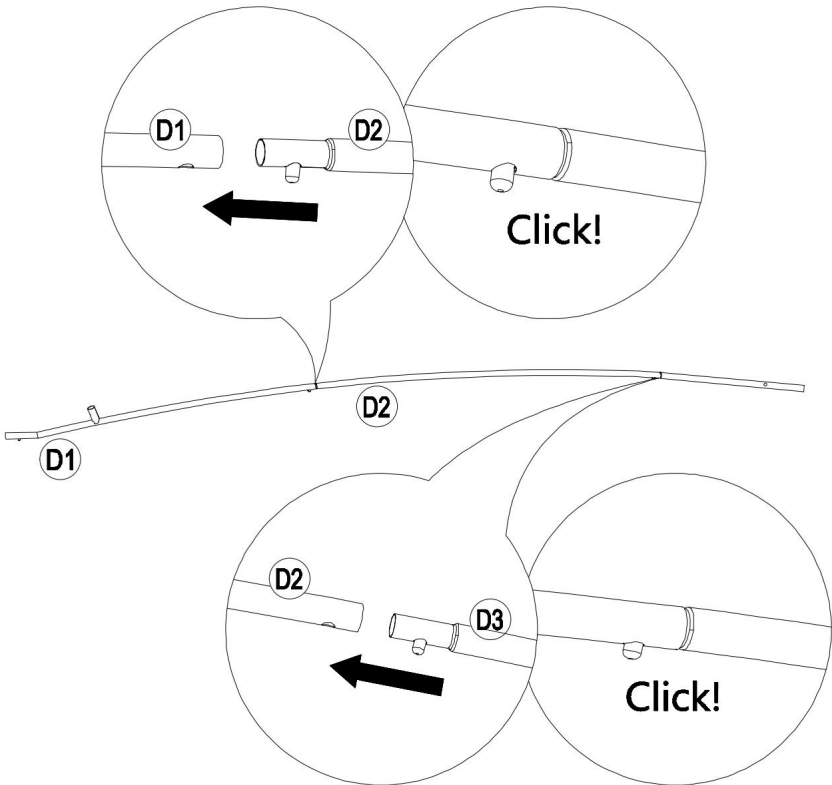
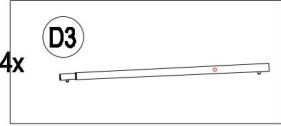
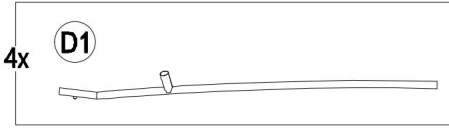

9

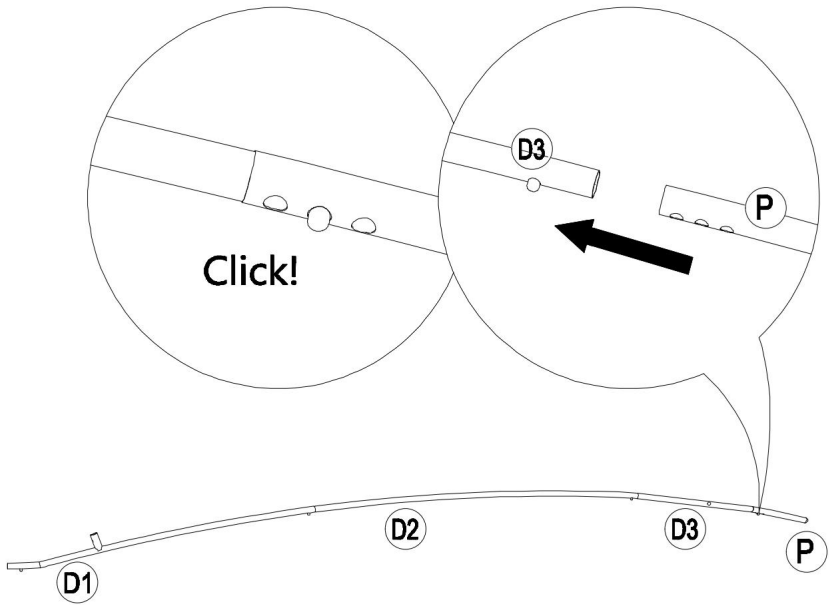
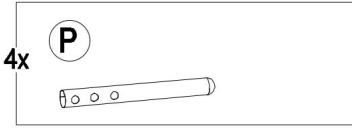

10

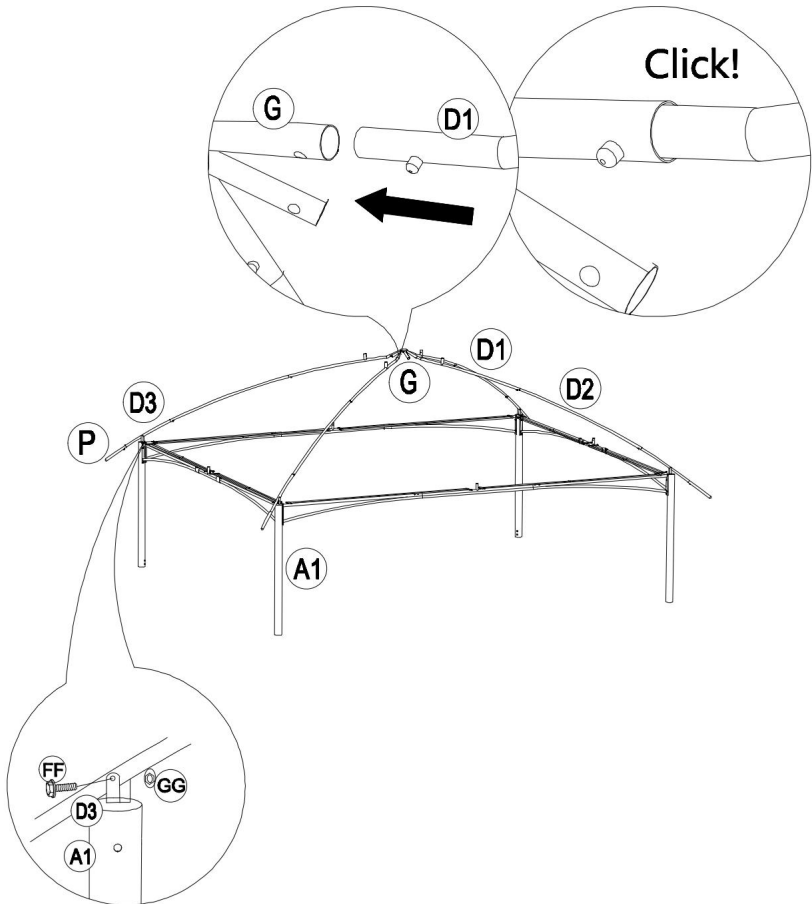
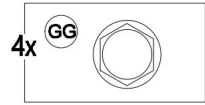
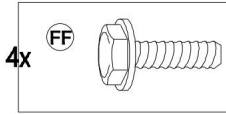
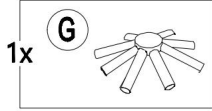
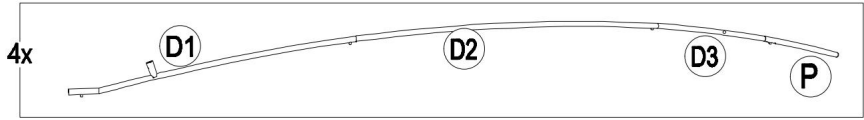

11

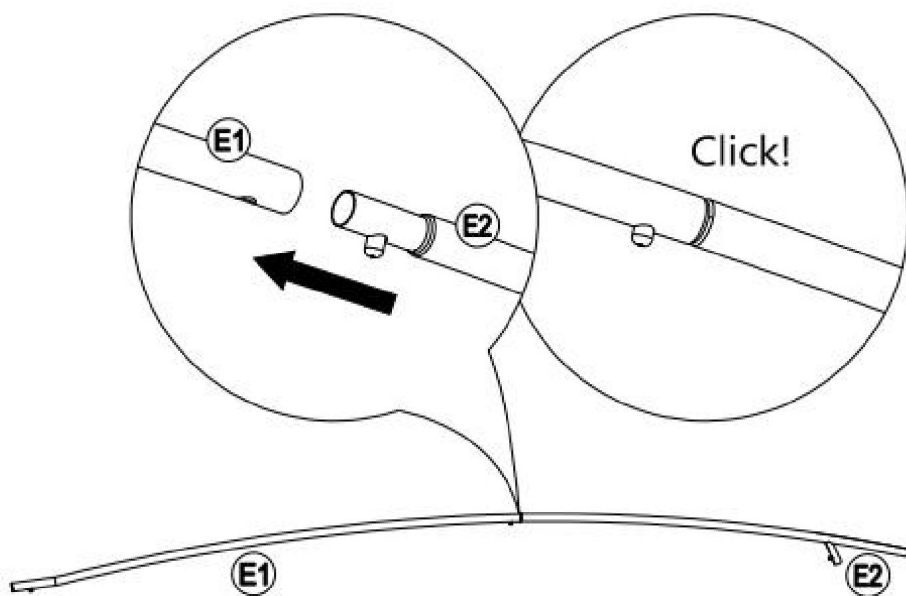
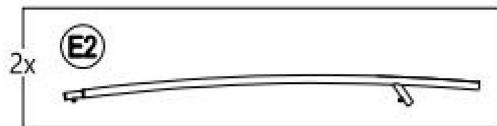

12

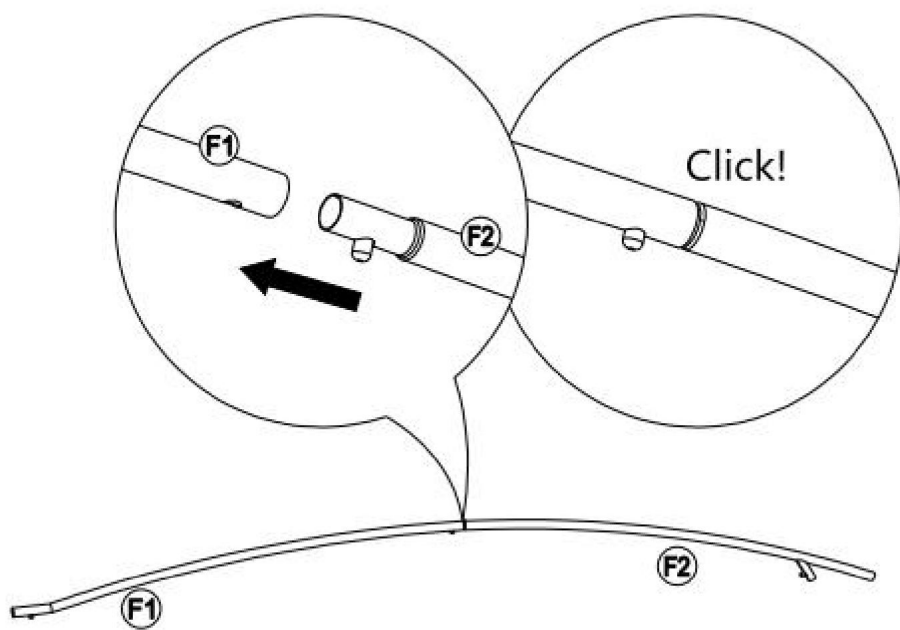
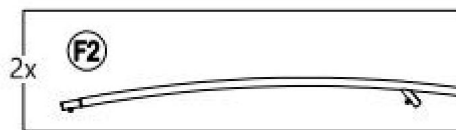
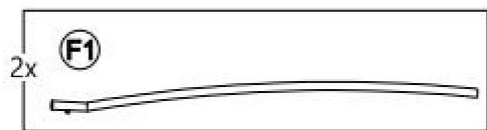

13

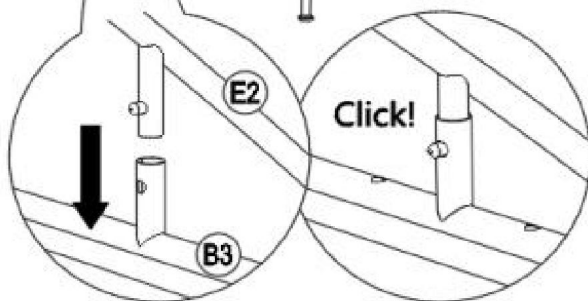
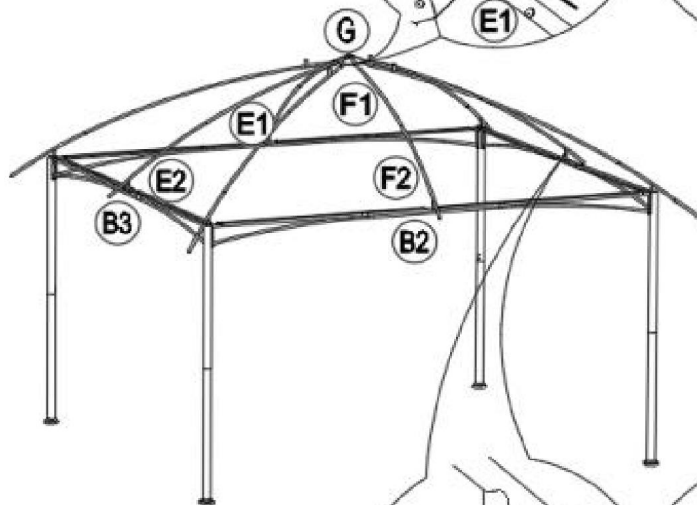
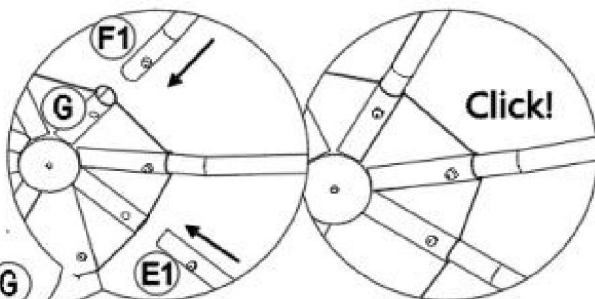
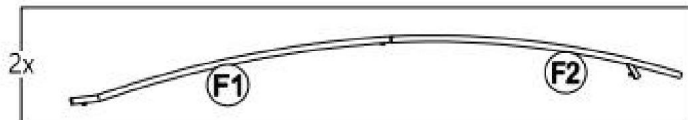
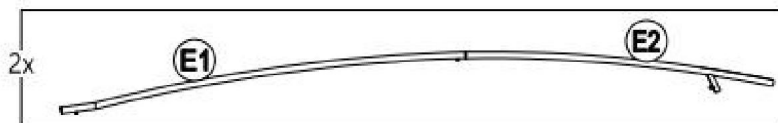

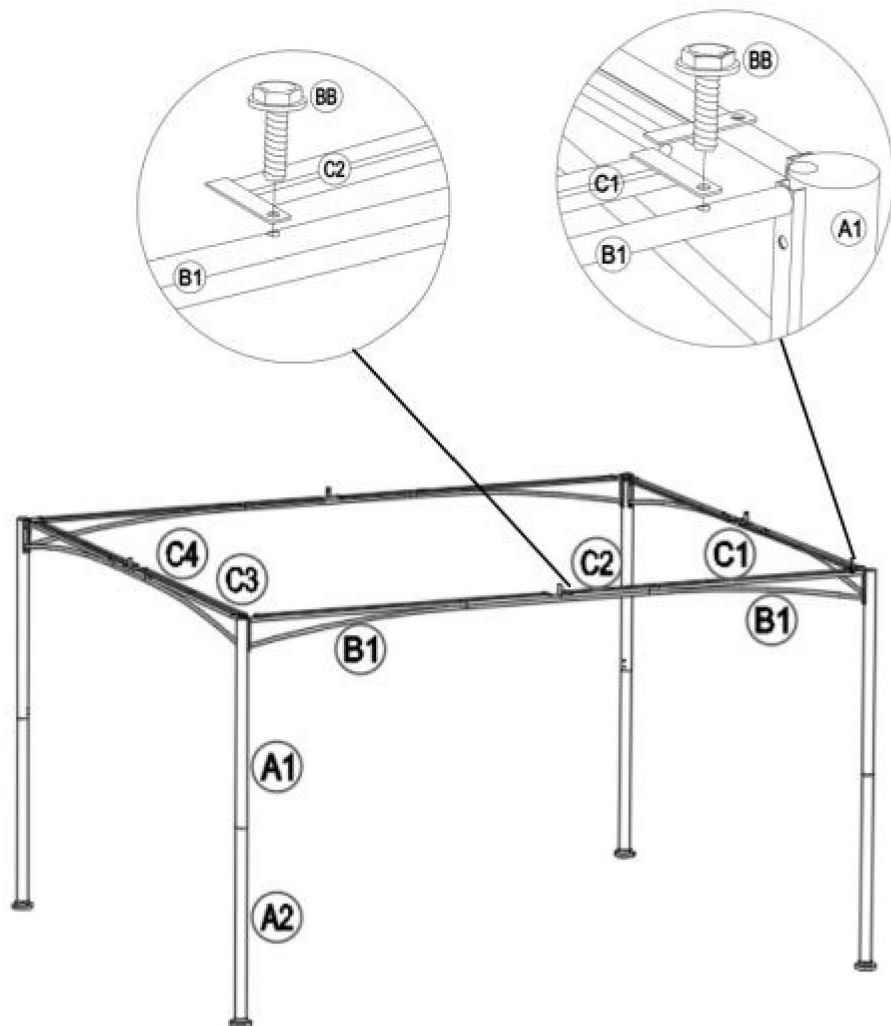

14

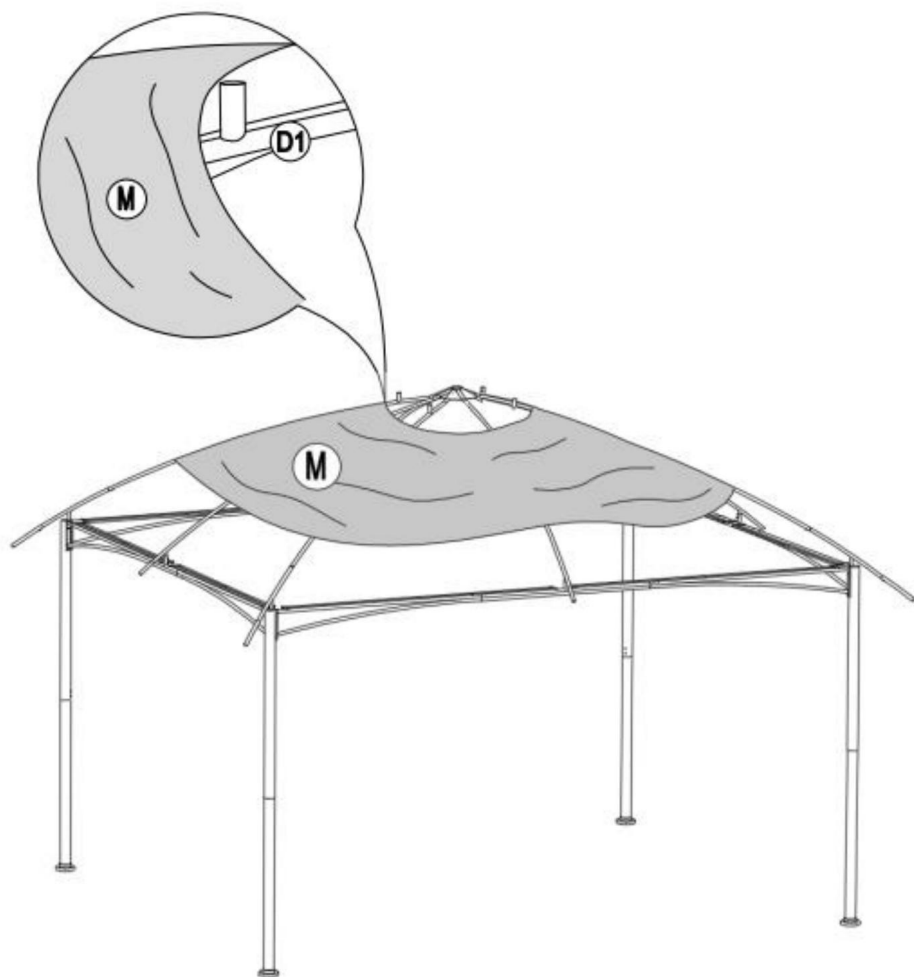
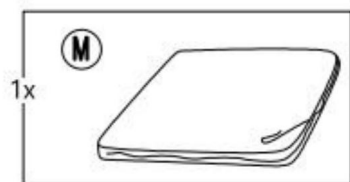

15

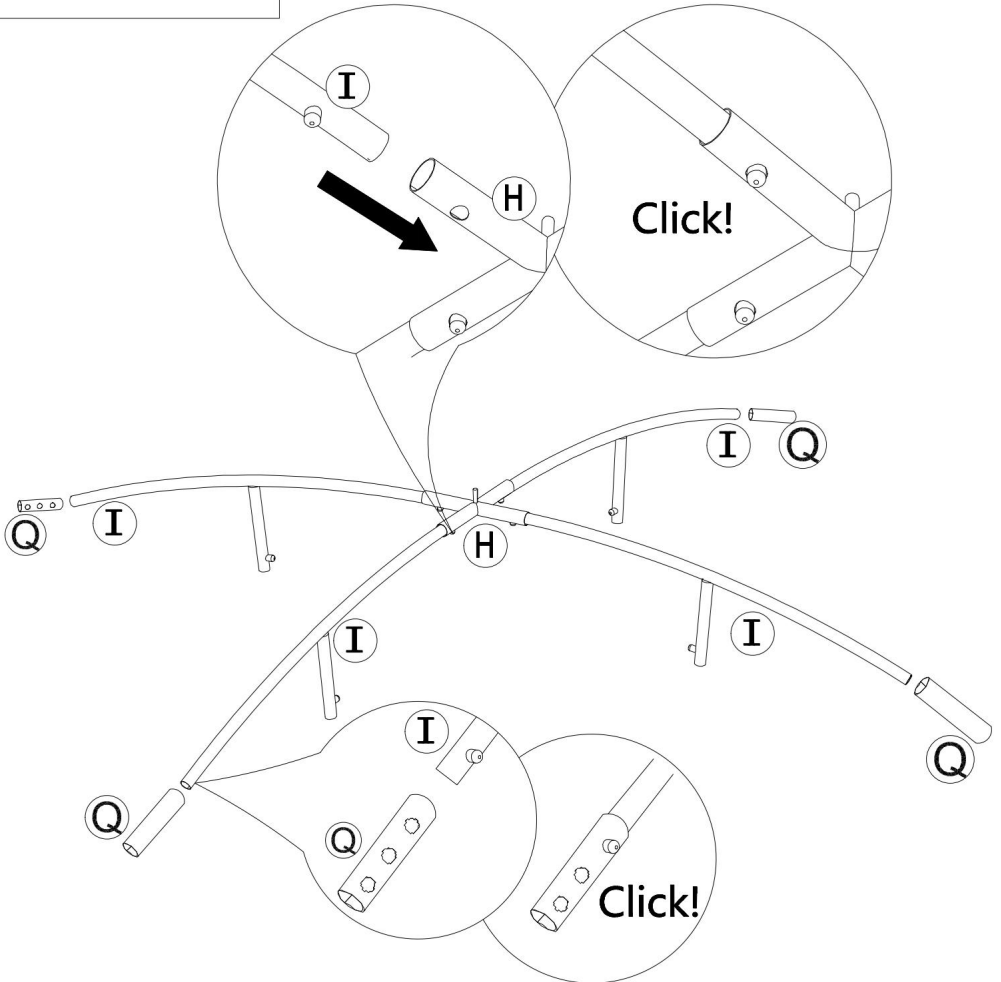
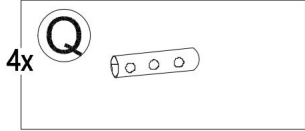
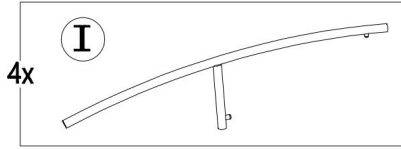
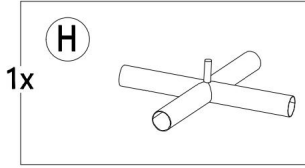

16

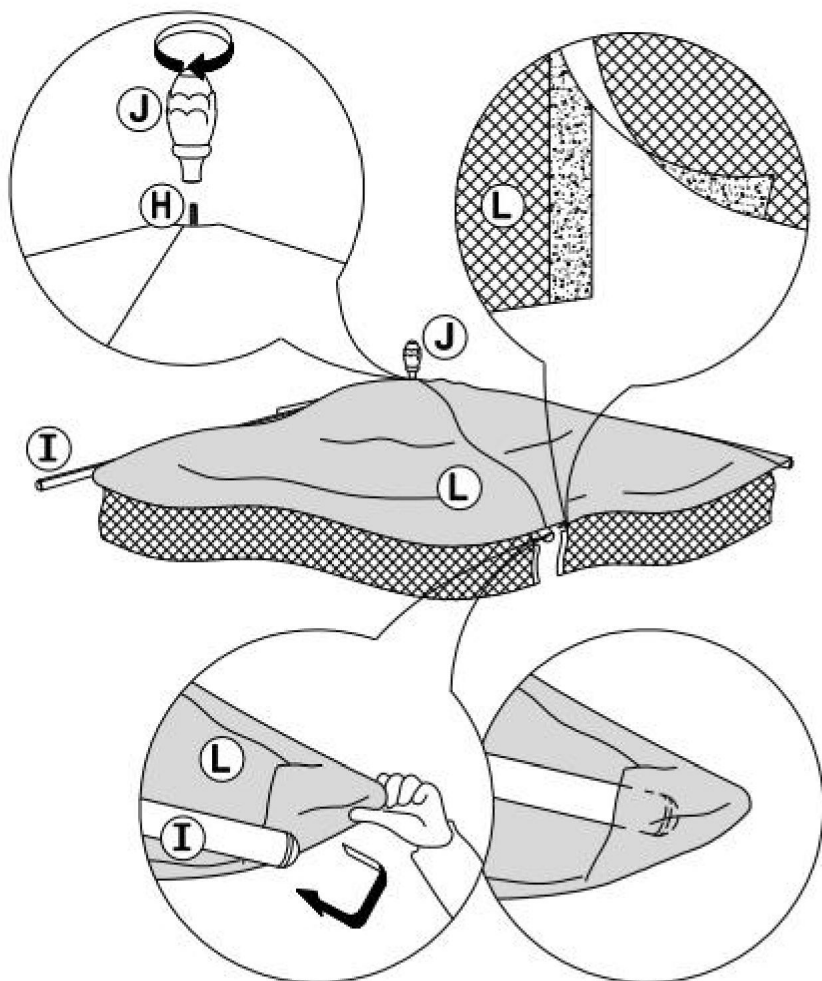
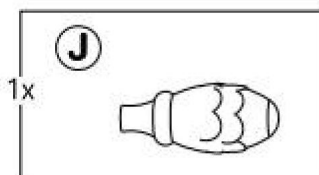
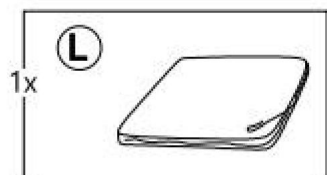

17

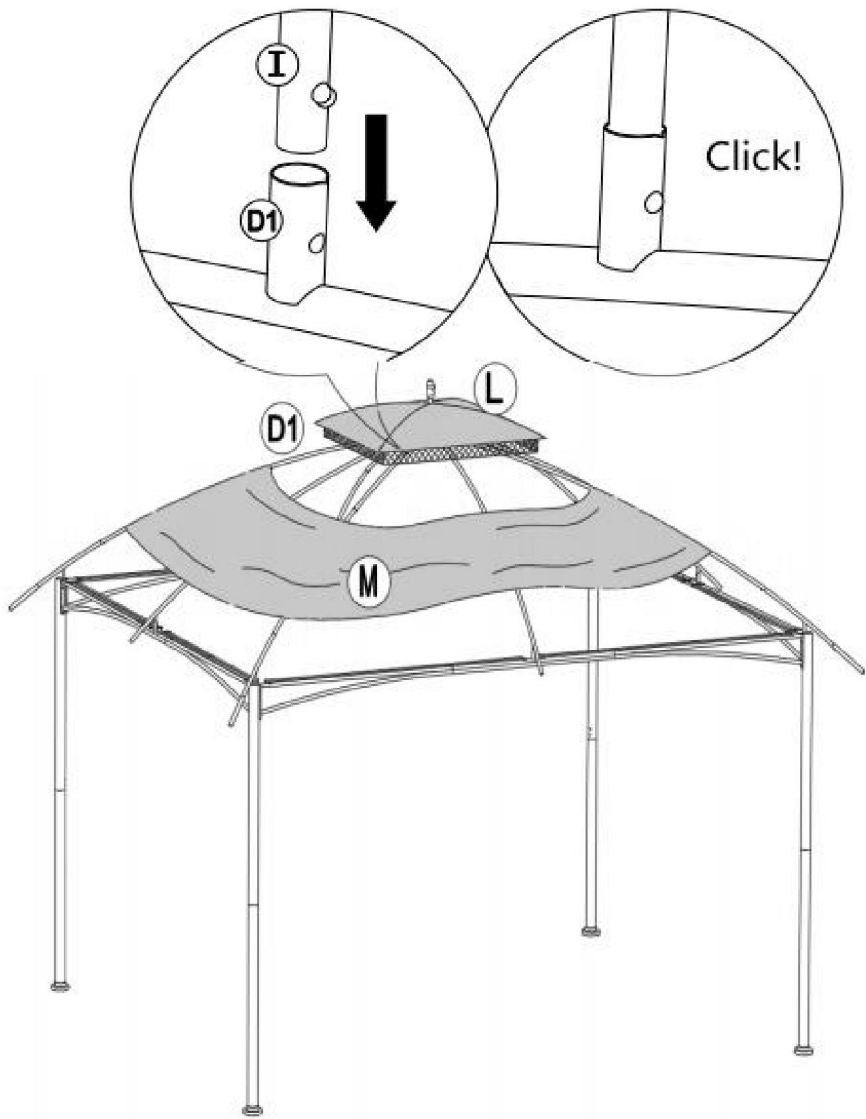

18

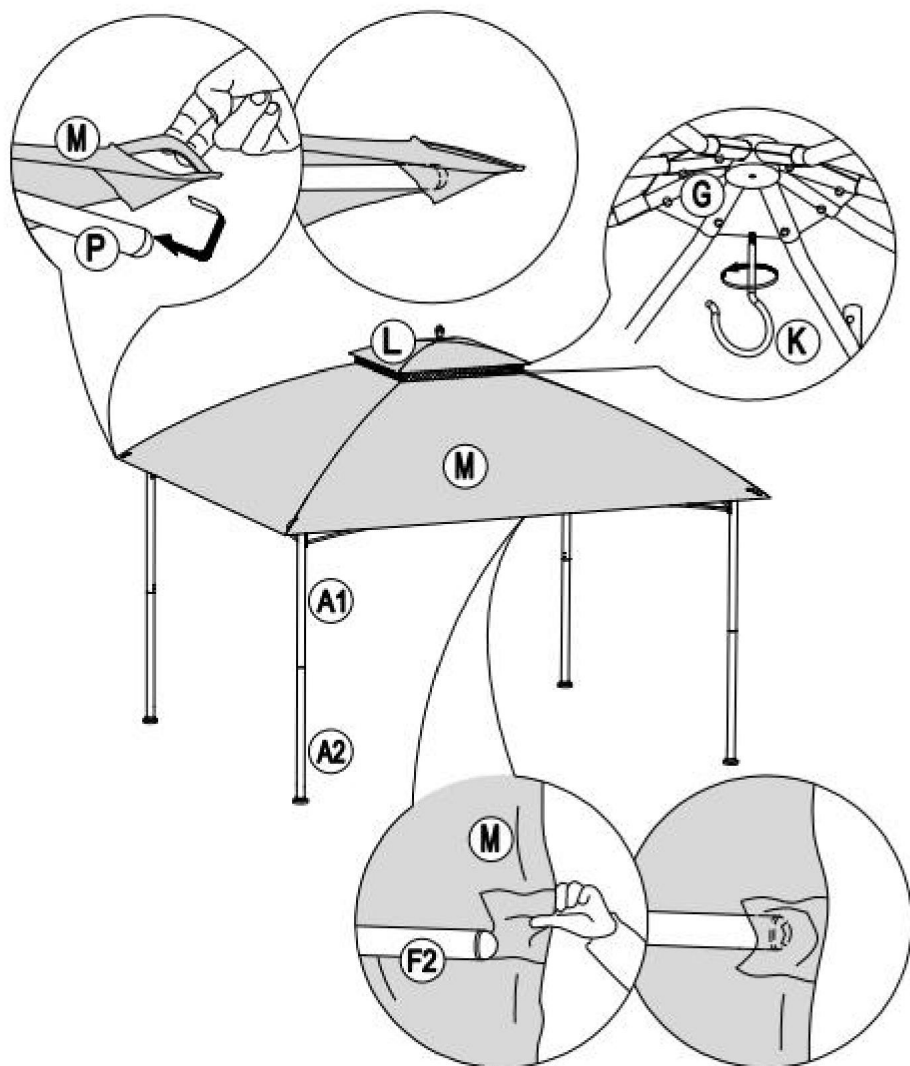
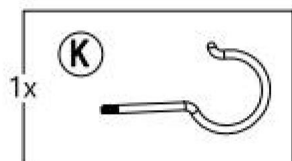

19

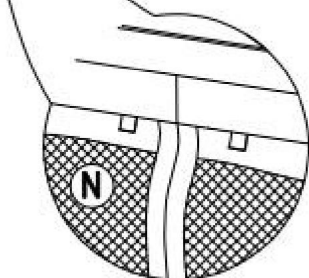
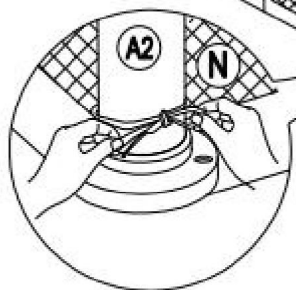
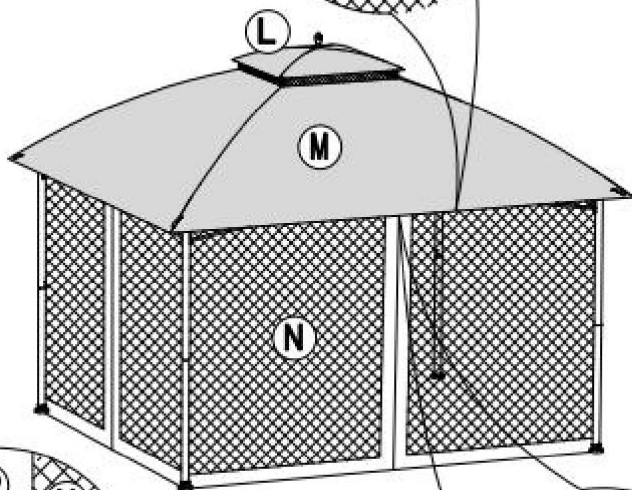
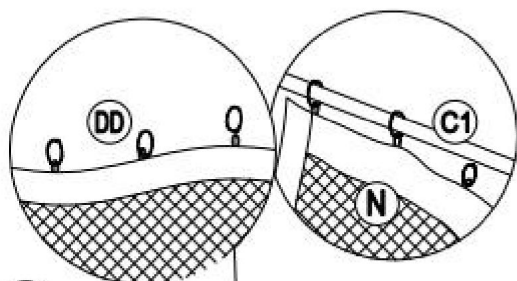
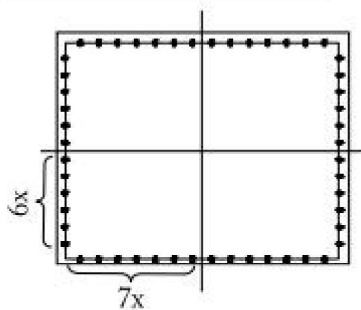
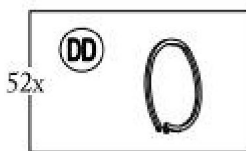
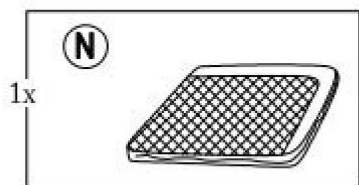

20

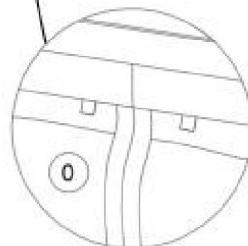
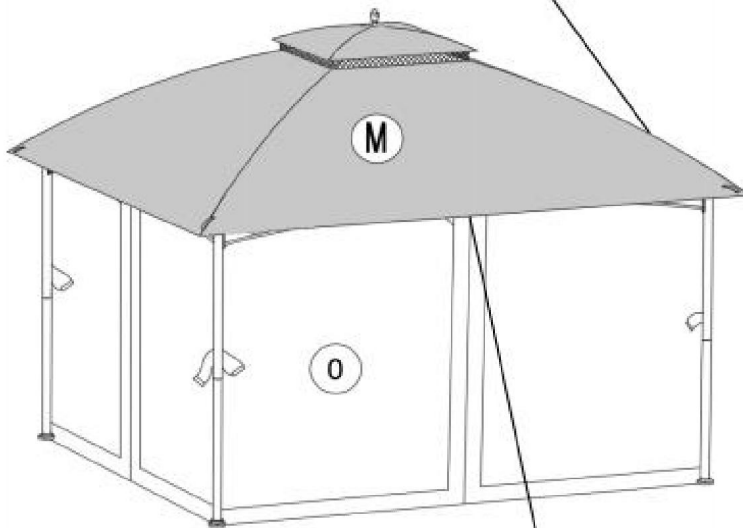
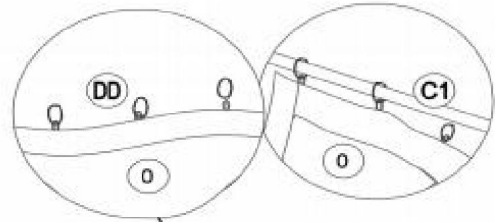
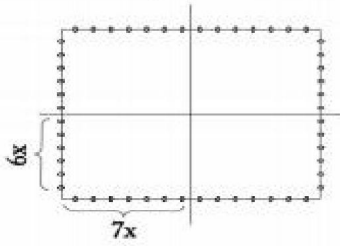
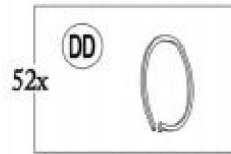
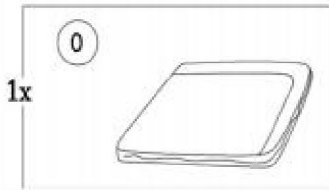

21

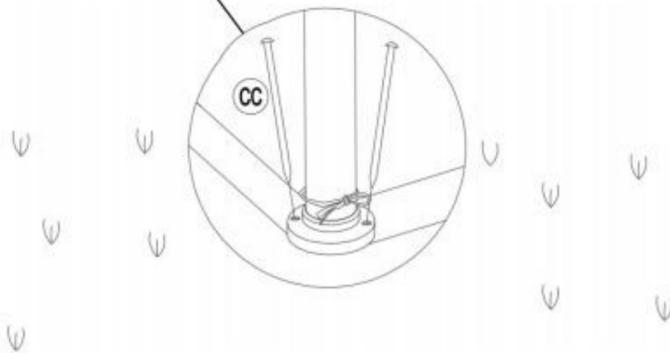
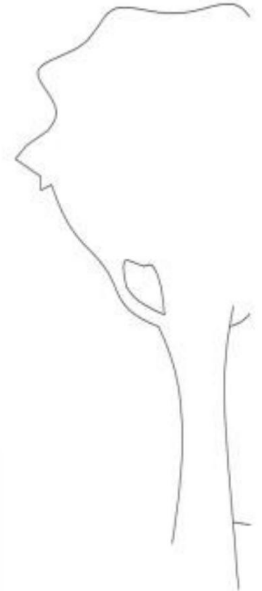
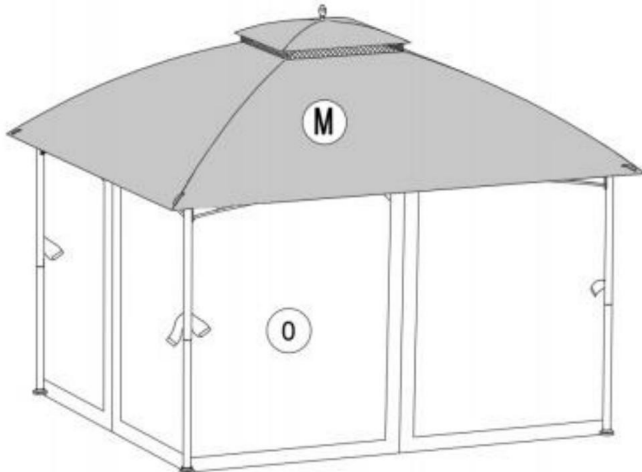

Importado a EE. UU.: Sanven Technology Ltd.
Suite 250, 9166 Anaheim Place, Rancho Cucamonga, CA 91730

VEVOR®

TOUGH TOOLS, HALF PRICE

Soporte técnico y certificado de garantía
electrónica www.vevor.com/support

VEVOR[®]

TOUGH TOOLS, HALF PRICE

Supporto tecnico e certificato di garanzia elettronica www.vevor.com/support

ISTRUZIONI PER GAZEBO DA PATIO

MODELLO:KD-TY007-1

Continuiamo a impegnarci per fornirvi strumenti a prezzi competitivi.

"Risparmia la metà", "Metà prezzo" o qualsiasi altra espressione simile da noi utilizzata rappresenta solo una stima del risparmio che potresti ottenere acquistando determinati utensili con noi rispetto ai principali marchi principali e non significa necessariamente coprire tutte le categorie di utensili da noi offerti. Ti ricordiamo cortesemente di verificare attentamente quando effettui un ordine con noi se stai effettivamente risparmiando la metà rispetto ai principali marchi principali

VEVOR®

TOUGH TOOLS, HALF PRICE

GAZEBO DA TERRAZZO

Codice articolo: KD-TY007-1

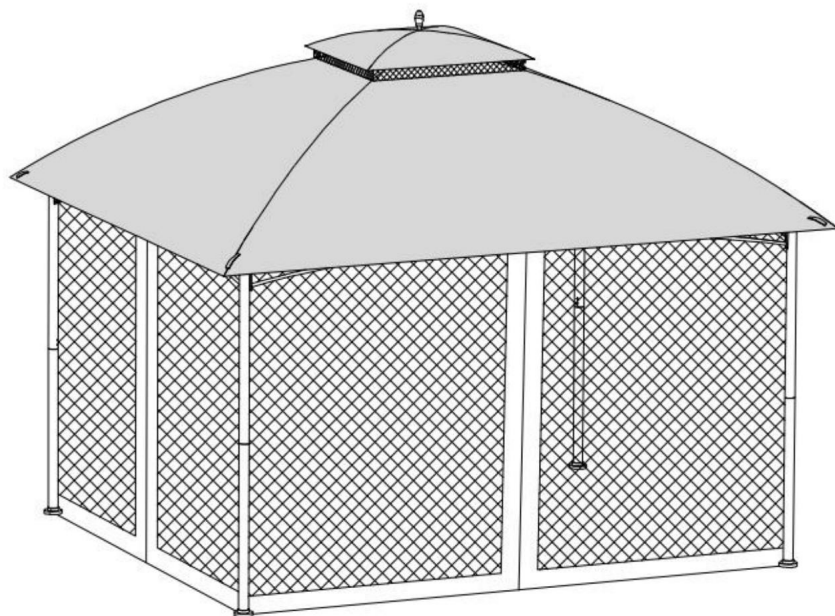

HAI BISOGNO DI AIUTO? CONTATTACI!

Hai domande sui prodotti? Hai bisogno di supporto tecnico? Non esitare a contattarci:

Supporto tecnico e certificato di garanzia elettronica www.vevor.com/support

Questa è l'istruzione originale, si prega di leggere attentamente tutte le istruzioni del manuale prima di utilizzare. VEVOR si riserva una chiara interpretazione del nostro manuale utente. L'aspetto del prodotto sarà soggetto al prodotto ricevuto. Vi preghiamo di perdonarci se non vi informeremo di nuovo se ci sono aggiornamenti tecnologici o software sul nostro prodotto.

ISTRUZIONI DI MONTAGGIO E SICUREZZA

Si prega di prestare molta attenzione alle seguenti istruzioni per ridurre il rischio di lesioni, incidenti o danni al prodotto stesso.

IMPORTANTE

Si prega di seguire TUTTE le istruzioni di sicurezza elencate di seguito.

Si prega di rimuovere il materiale di imballaggio prima di montare o utilizzare il prodotto.

Si prega di assicurarsi che tutte le parti elencate siano incluse nella confezione e che siano non danneggiato.

Si prega di leggere attentamente le presenti istruzioni di montaggio e di sicurezza prima di utilizzare il tenda e conservarla per riferimento futuro.

Questo prodotto deve essere utilizzato solo per scopi non commerciali.

INFORMAZIONI SULLA SICUREZZA

La tenda non è stata testata per carichi di vento e neve, a meno che ciò non sia chiaramente indicato altrimenti. Pertanto, questi carichi non sono coperti da garanzia. Si prega di guardare il previsioni meteo per poter proteggere o smontare adeguatamente la tenda prima si presentano dei problemi.

Le tende devono essere utilizzate solo come alloggi temporanei e devono essere smontato in condizioni meteorologiche avverse.

Assicuratevi di mantenere una distanza sufficiente dalle case e dalle linee elettriche e del gas. evitare possibili danni. Si prega di controllare la zona per cavi di alimentazione e linee del gas. Se necessario, chiedi ulteriori informazioni alle autorità locali.

Quando si utilizzano riscaldatori adatti, mantenere una distanza minima di 1,2 m dal telo materiale. Fuoco aperto o riscaldatori con fiamme libere come riscaldatori da patio, ombrelli In nessun caso all'interno della tenda devono essere utilizzati riscaldatori, stufe a gas ecc.

La persona che si occupa della costruzione della tenda è responsabile di un'adeguata fissandolo per garantirne la sicurezza. Si prega di controllare costantemente l'ancoraggio per evitare danni. Un ancoraggio stabile può prolungare la durata della tenda.

Per garantire la vostra sicurezza, assicuratevi di indossare i guanti.

Le parti metalliche potrebbero avere bordi taglienti e potrebbero essere oleose a causa della ruggine trattamento preventivo.

Si prega di assicurarsi che non vi sia alcun carico di neve permanente. Dovrebbe essere rimosso subito. Lo stesso vale per la pioggia e altre forme di carico.

Attenzione: tenere la plastica e i piccoli pezzi di ricambio fuori dalla portata dei bambini. una pellicola sottile può aderire al naso e alla bocca e impedire la respirazione.

MONTAGGIO E UTILIZZO

Si prega di riservare un po' più di tempo per la prima installazione della tenda. Le regole da seguire da seguire quando si monta la tenda sono semplici. Si prega di utilizzare le istruzioni illustrate per ogni fase dell'installazione.

Le viti che uniscono i tubi ai connettori devono essere serrate manualmente, utilizzando un chiave esagonale o cacciavite automatico, impostato al livello massimo 2, per evitare che il materiale Indossare.

La tenda deve essere montata solo da almeno due adulti. Si prega di tenere i bambini lontano dalla tenda durante il montaggio per proteggerli.

Assicuratevi di trovare una base piana e uniforme adatta al terreno montaggio del prodotto e suo utilizzo previsto.

Utilizzare esclusivamente i materiali forniti insieme alla tenda.

I teloni non devono entrare in contatto con oggetti con bordi taglienti.

La tenda può essere utilizzata a temperature prossime allo zero. Tuttavia, prima di tale utilizzare, il materiale del telo deve essere conservato a una temperatura di almeno 10°C. Si prega di assicurarsi che il telo non si rompa quando viene piegato.

Ogni paese ha normative diverse per quanto riguarda le strutture mobili (tende) e strutture inamovibili. Si prega di chiedere alle autorità locali se è necessario un permesso deve essere ottenuto per montare la tenda. In alcuni paesi, questo dipende dalle dimensioni della la tenda.

ISTRUZIONI PER LA CURA E LA CONSERVAZIONE

Non sono coperti danni di alcun tipo dovuti ad eventi naturali (danni causati da agenti atmosferici).

La tenda può essere utilizzata a temperature prossime allo zero. Tuttavia, prima di tale utilizzare, il materiale del telo deve essere conservato a una temperatura di almeno 10°C. Si prega di assicurarsi che il telo non si rompa quando viene piegato.

I venti forti potrebbero danneggiare il prodotto. Si prega di non lasciare il gazebo incustodito per un lungo periodo di tempo.

L'esposizione alla luce solare può causare lo sbiadimento del colore del telo. Questo non ha incide sulla fruibilità del braciere e non è considerato un difetto del prodotto.

Piogge intense o intense possono causare l'accumulo di sacche d'acqua sul tetto. Queste tasche devono essere rimosse il prima possibile.

Si prega di non utilizzare prodotti chimici aggressivi per pulire il materiale del telone. Il migliore l'agente detergente è acqua con una reazione leggermente alcalina.

Non apportare modifiche alla struttura metallica della tenda, ad esempio ad esempio, collegare e/o saldare carichi aggiuntivi, realizzare scanalature e/o qualsiasi deformazioni.

Per evitare danni, rimuovere il telo quando il prodotto non è in uso.

Vi consigliamo di smontare il padiglione in caso di maltempo e stagione invernale.

La tenda/telo deve essere piegata, imballata e riposta solo quando è completamente asciutta. Si prega di non appoggiare altri oggetti sopra la tenda/telo quando è riposto.

SPECIFICHE

Model	KD-TY007-1
Product Size	2970×3920×3530mm
Color	Beige/Brown/Black

UTENSILI

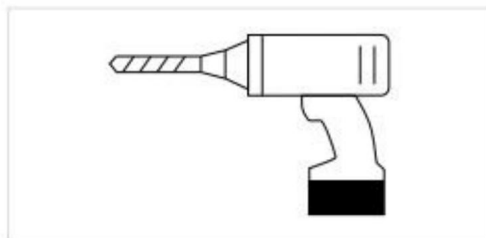





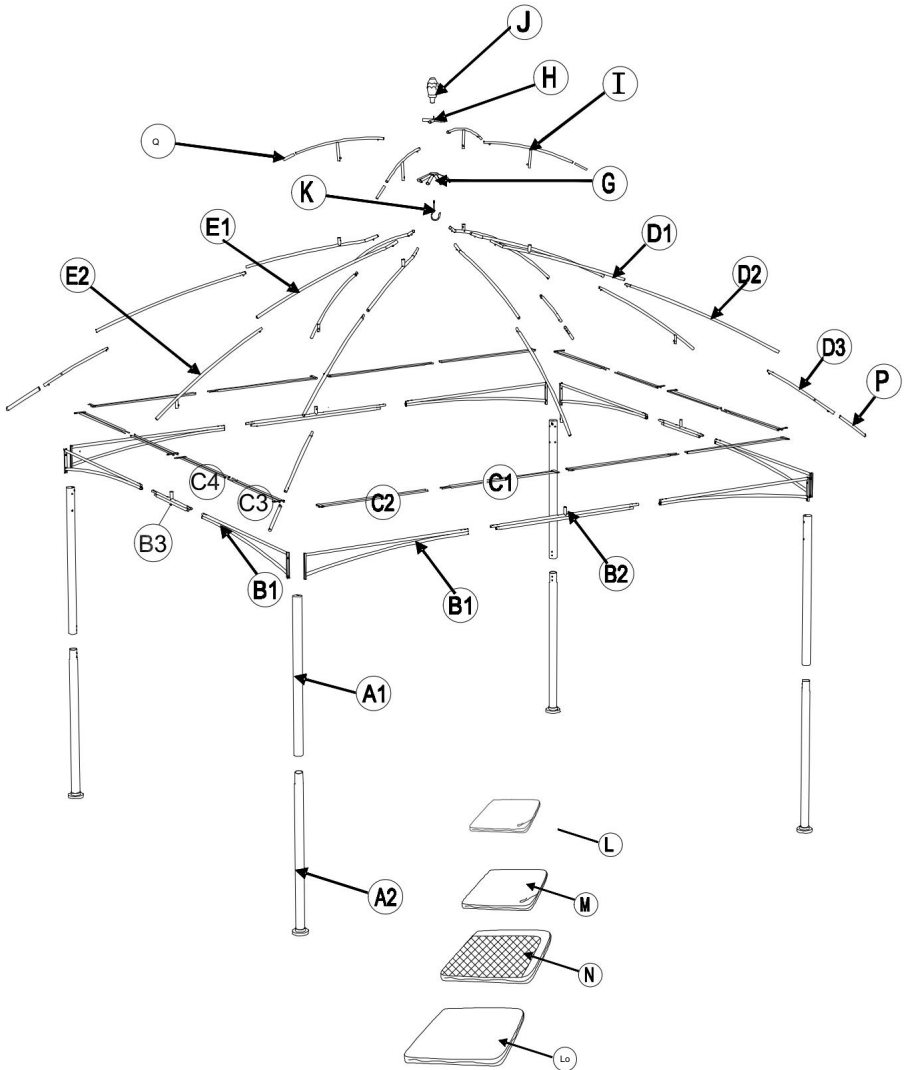
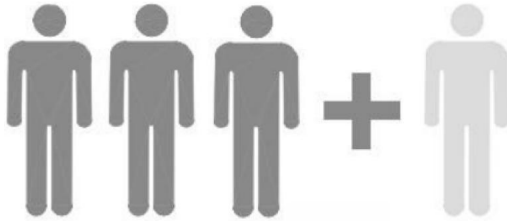





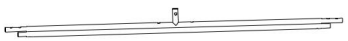
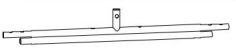













IMPORTANT





People needed for installation work

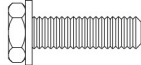
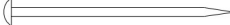

Parts List

Label	Qty	Part Image
A1	4	
A2	4	
B1	8	
B2	2	
B3	2	
C1	4	
C2	4	
C3	4	
C4	4	
D1	4	
D2	4	
D3	4	
E1	2	
E2	2	
F1	2	
F2	2	
G	1	
H	1	

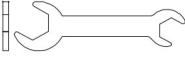
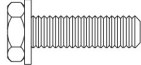
Parts list		
Label	Qty	Parts Image
I	4	
J	1	
K	1	
L	1	
M	1	
N	1	
P	4	
O	1	
Q	4	

Parts list				
Label	Description	Qty	Add	Parts Image
AA	M5*15	24	2	
BB	M6*20	40	2	
CC	Φ8*180	8	0	
DD	/	104	3	
EE	M5/M6	1	0	
FF	M6*35	4	1	
GG	M6	4	1	

1

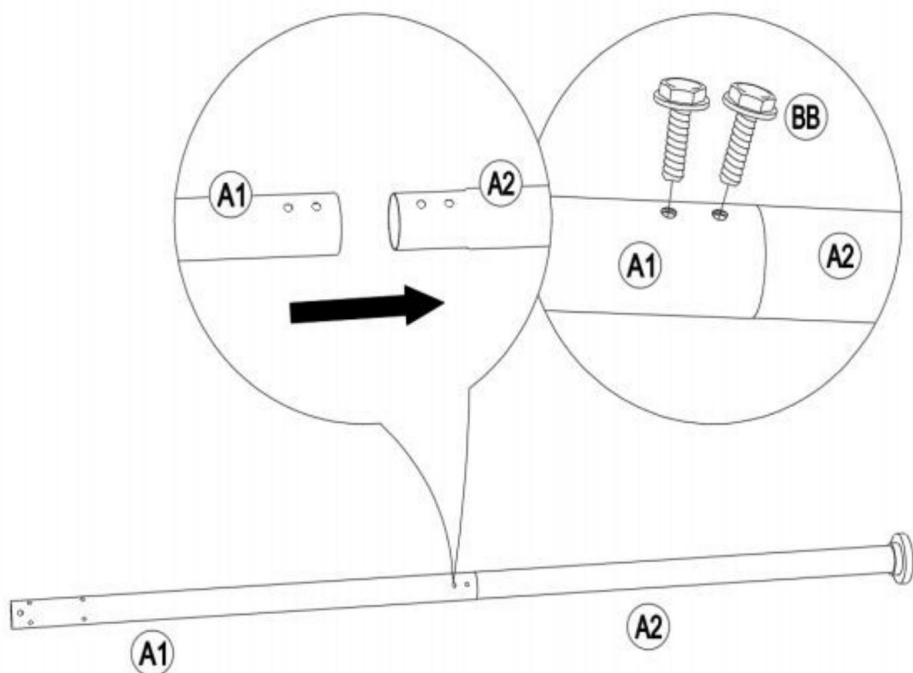
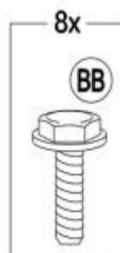
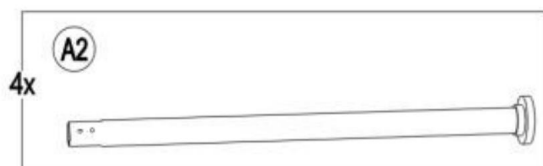

2

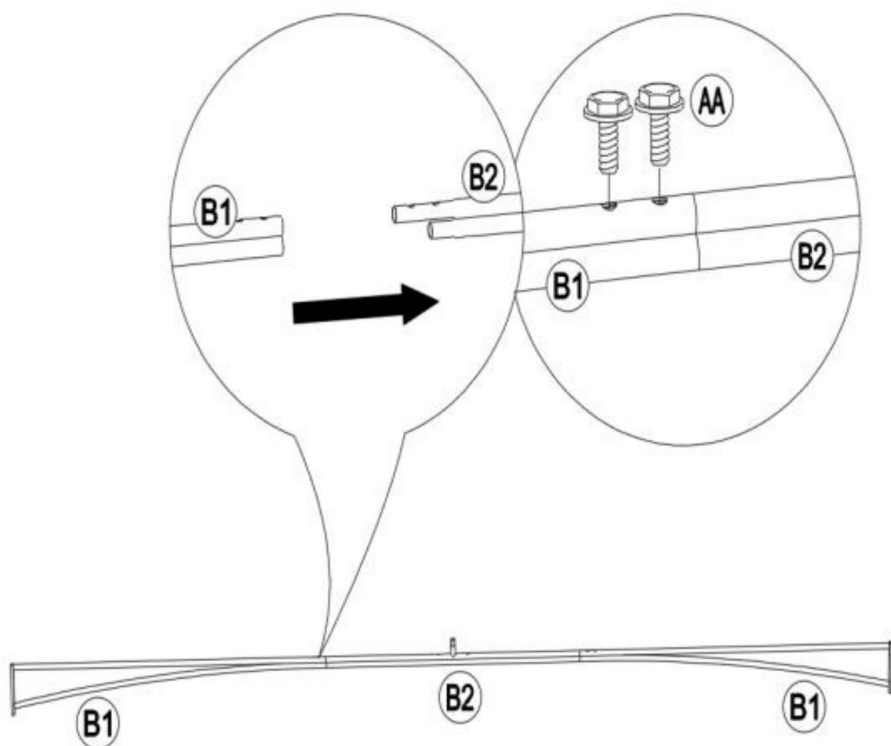
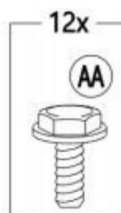
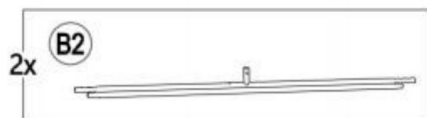
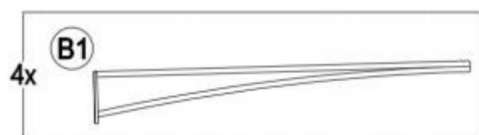

3

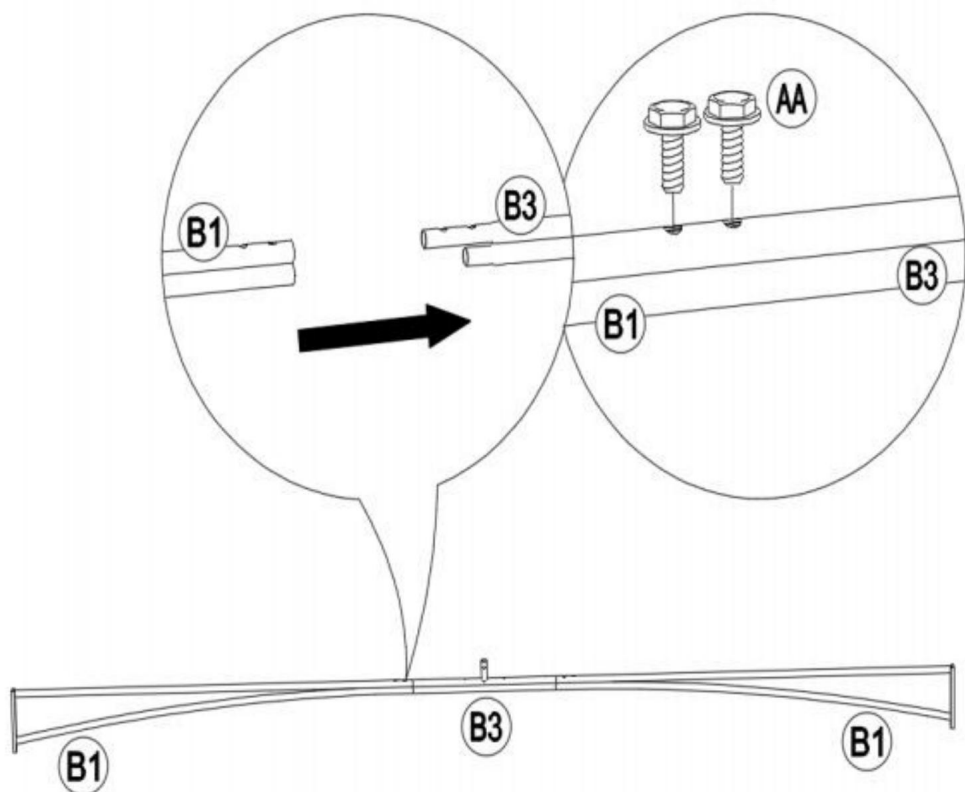
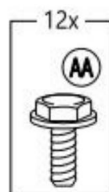
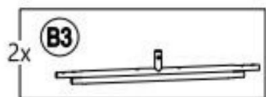
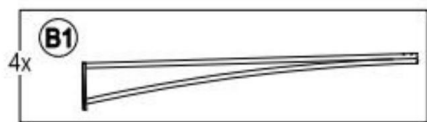

4

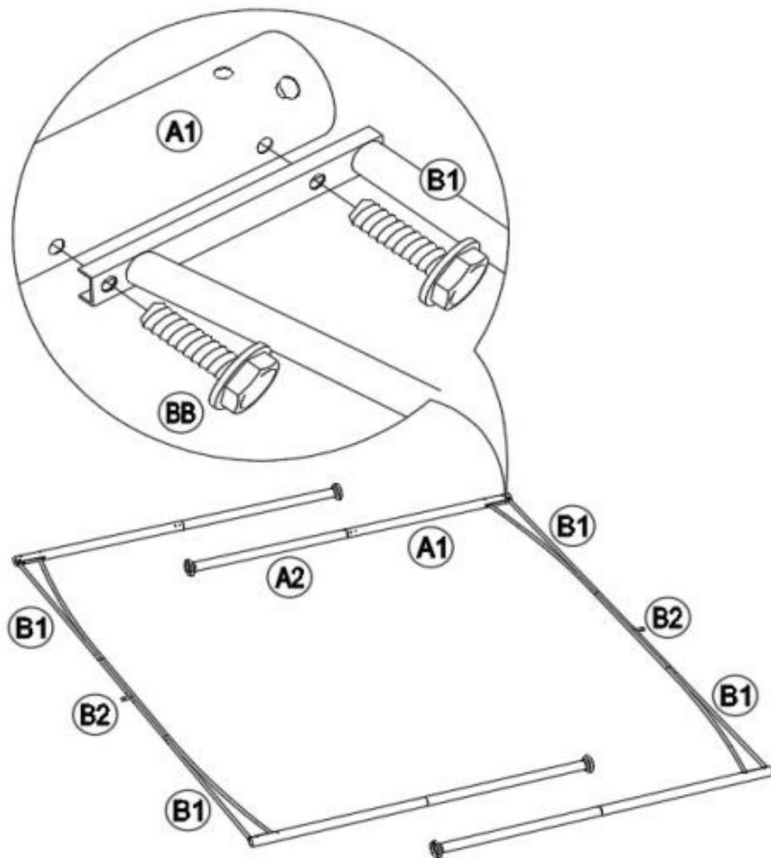
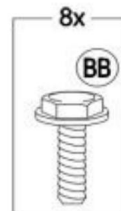
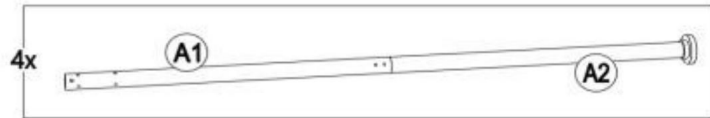
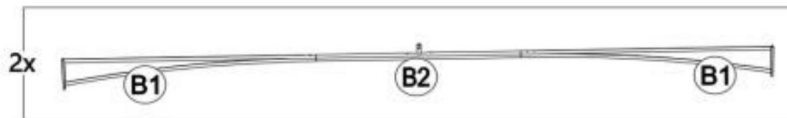

5

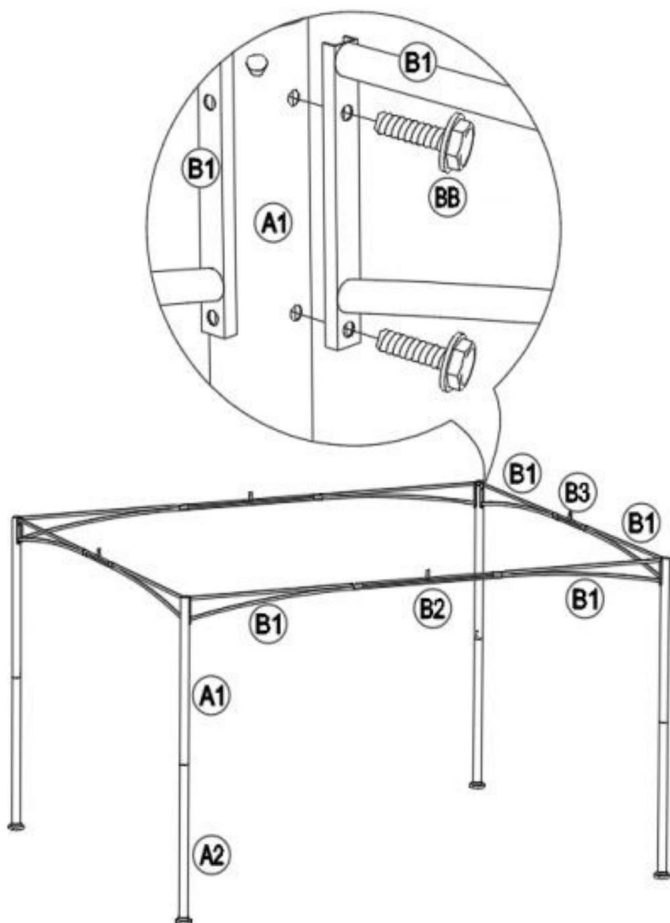
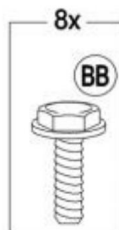
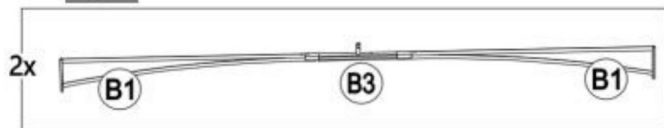

6

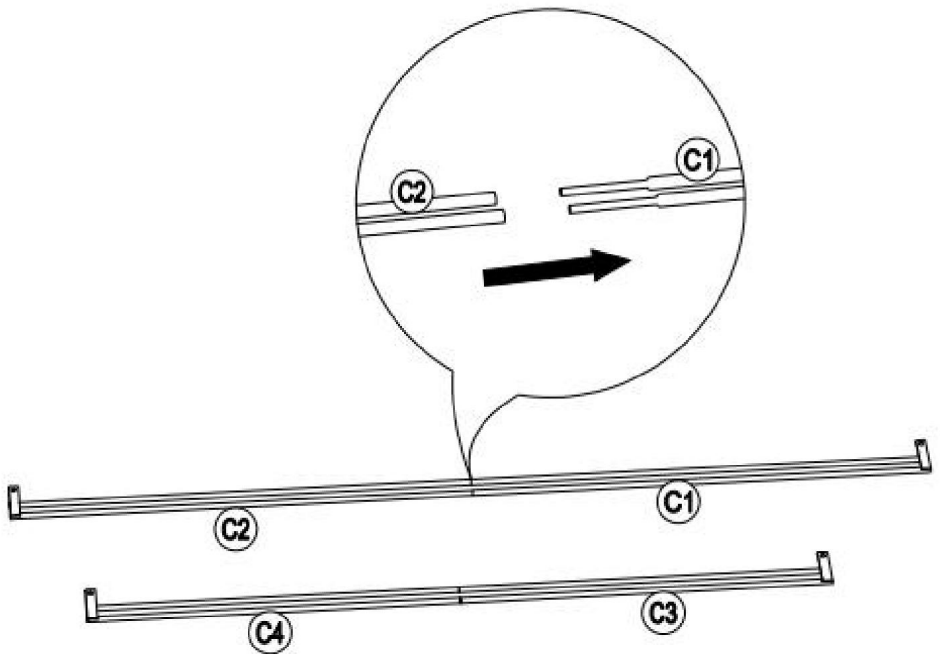
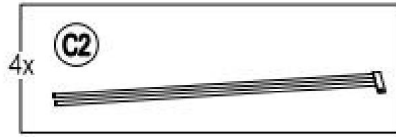
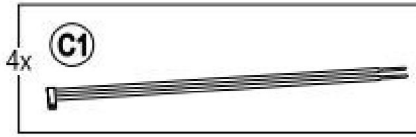

7

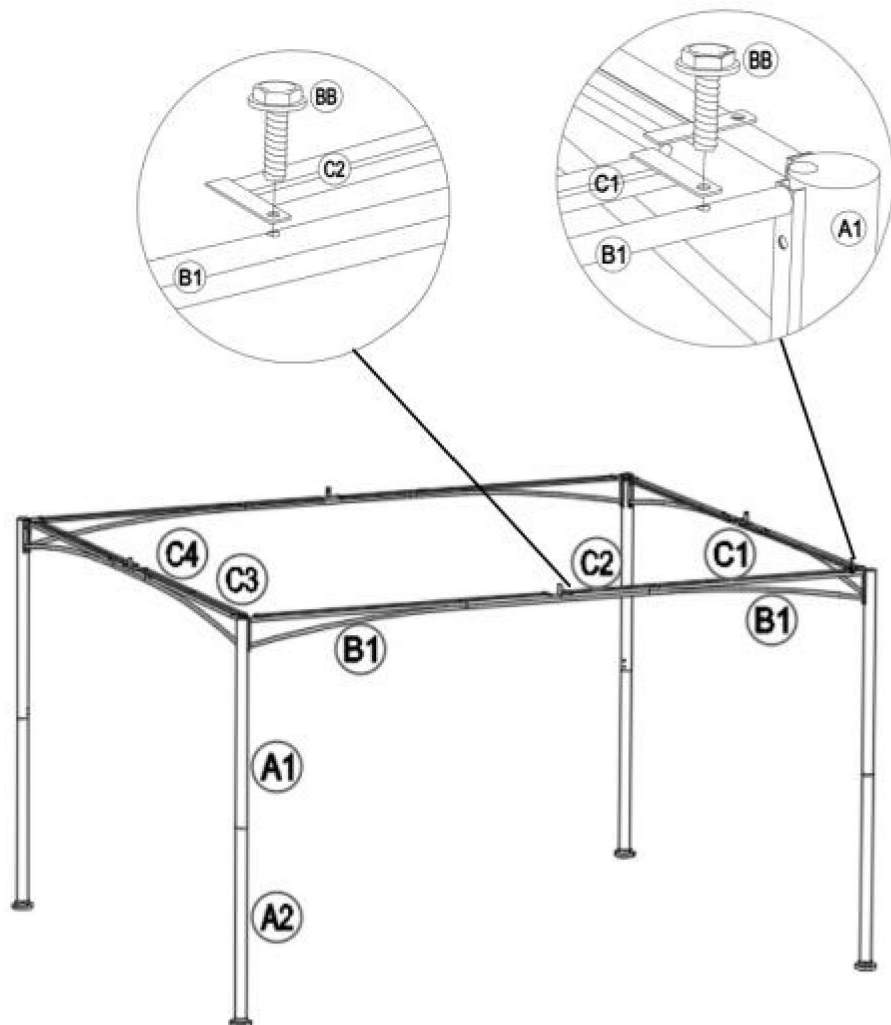
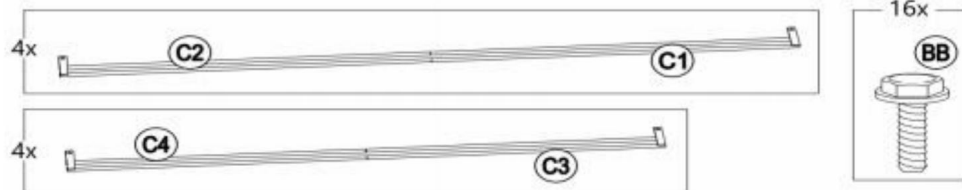

8

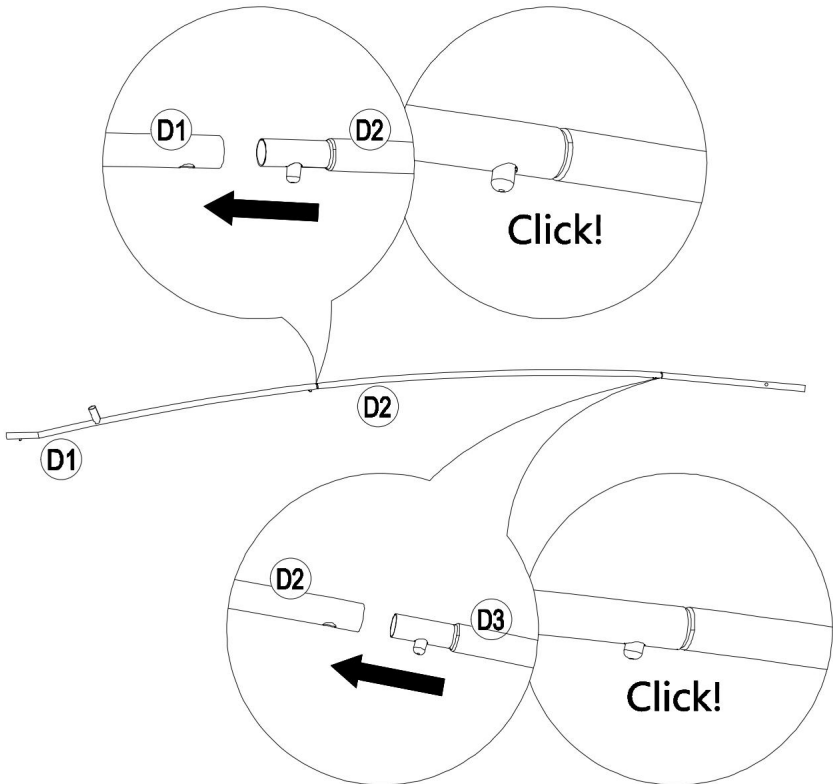
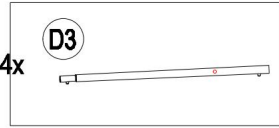
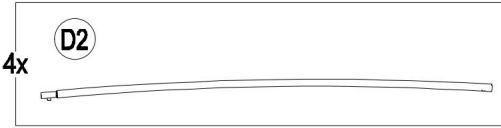
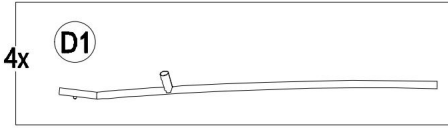

9

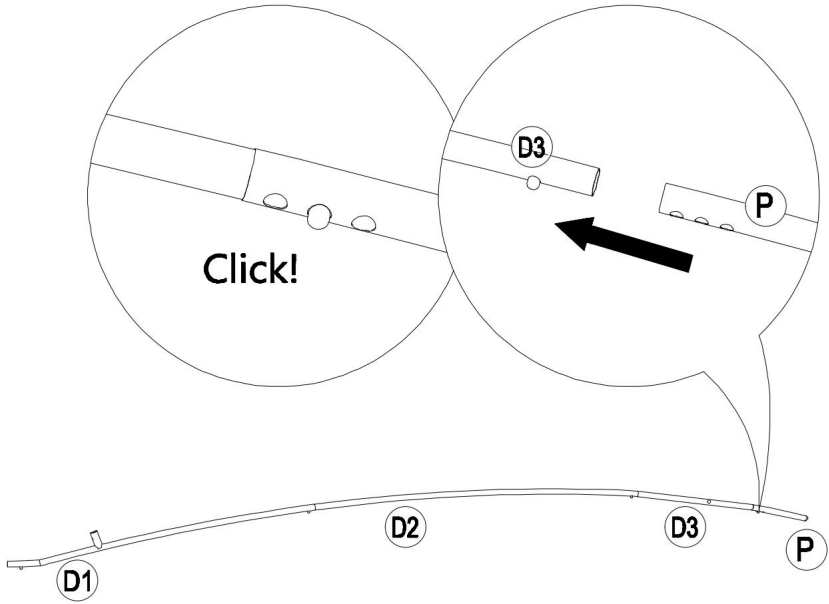
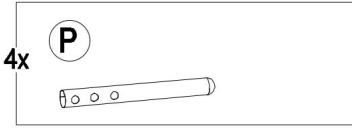

10

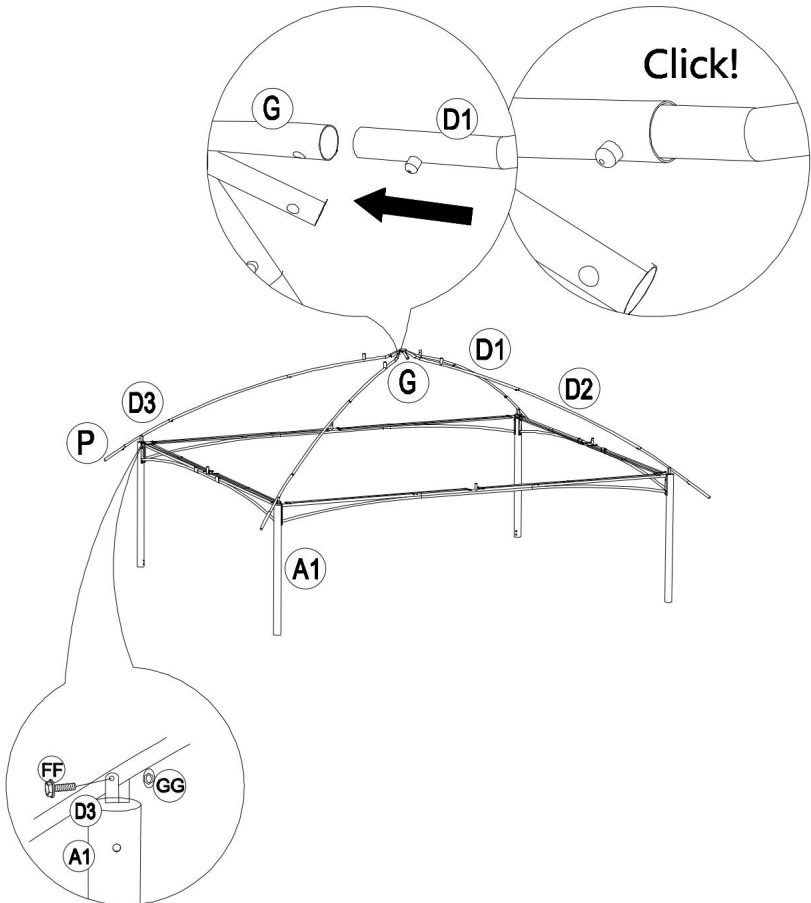
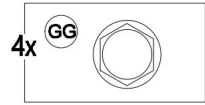
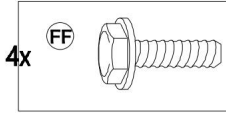
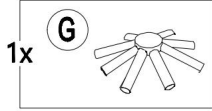
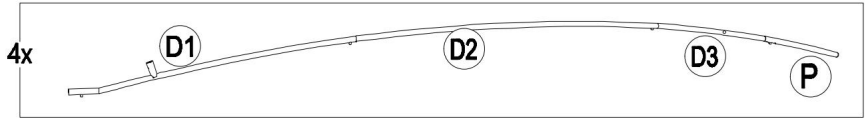

11

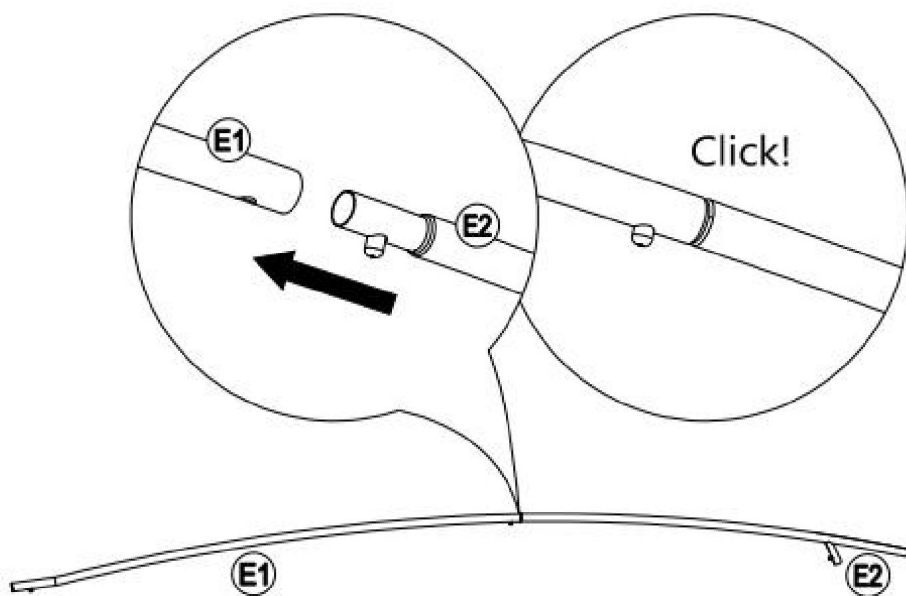
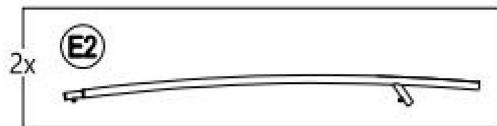

12

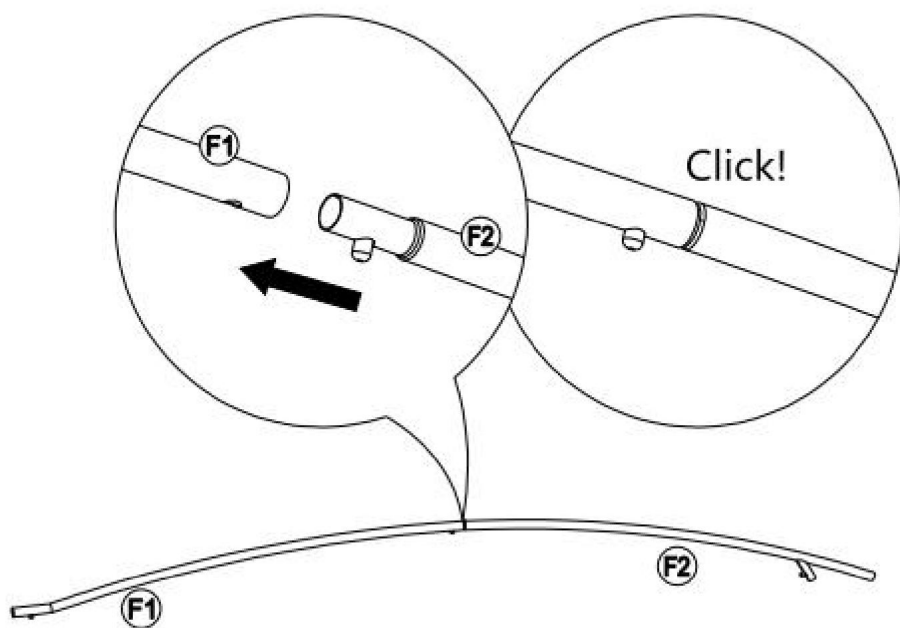
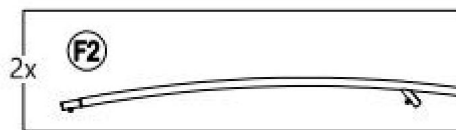
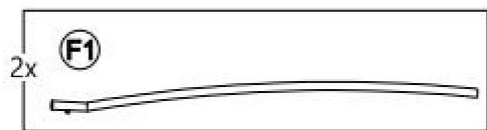

13

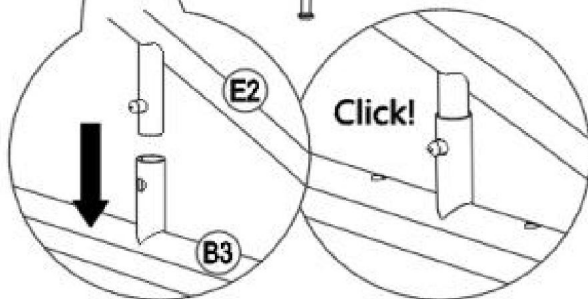
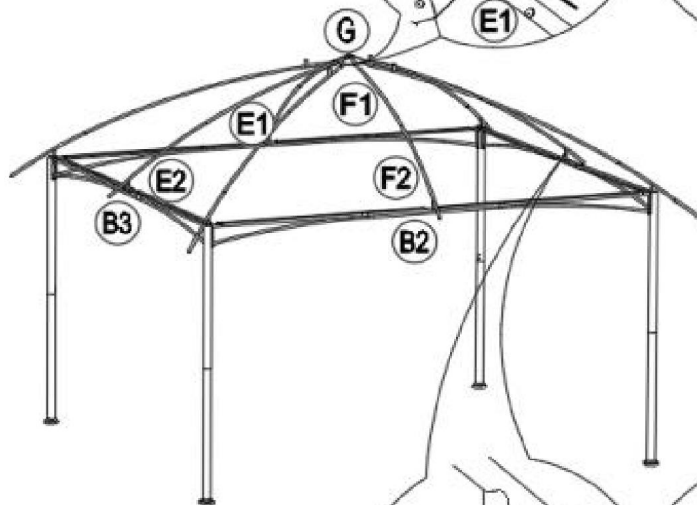
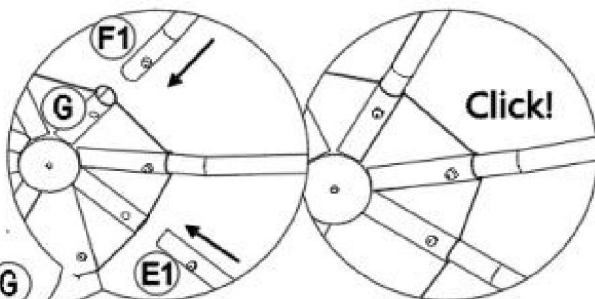
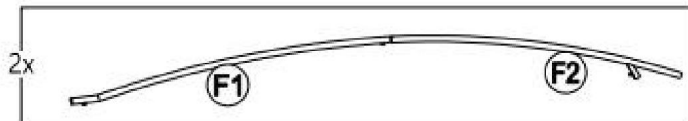
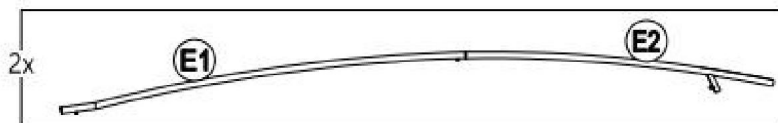

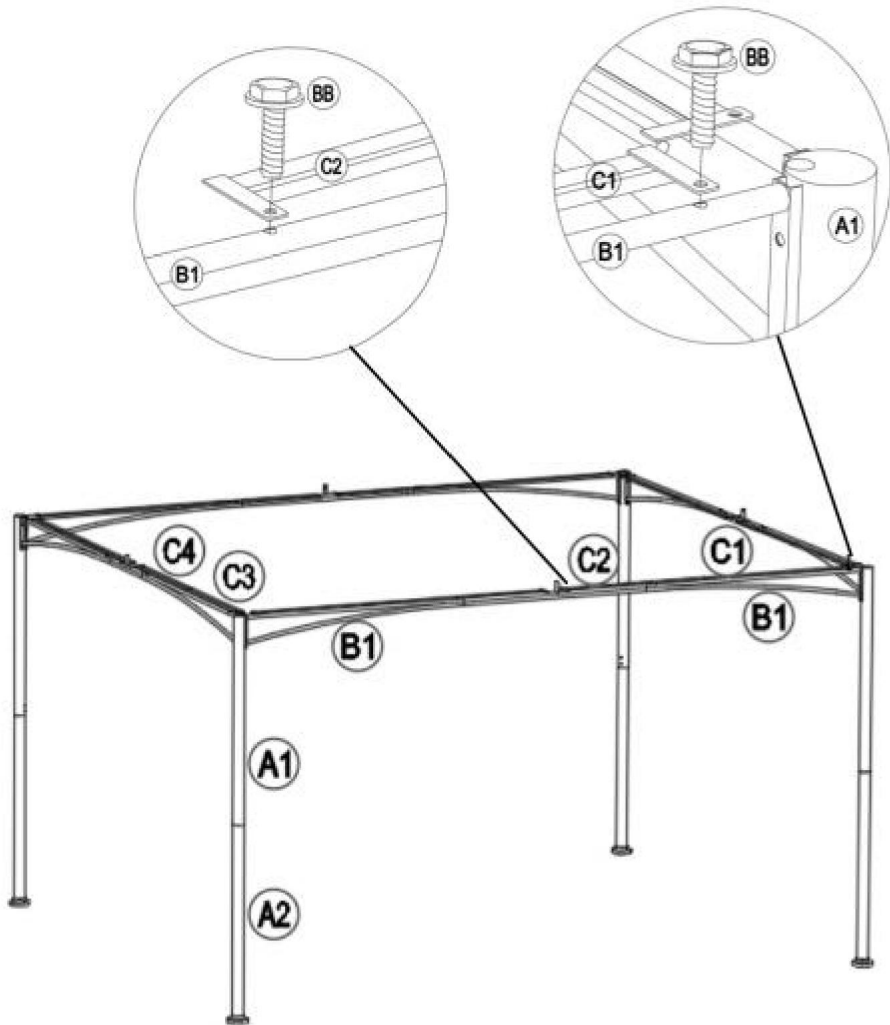

14

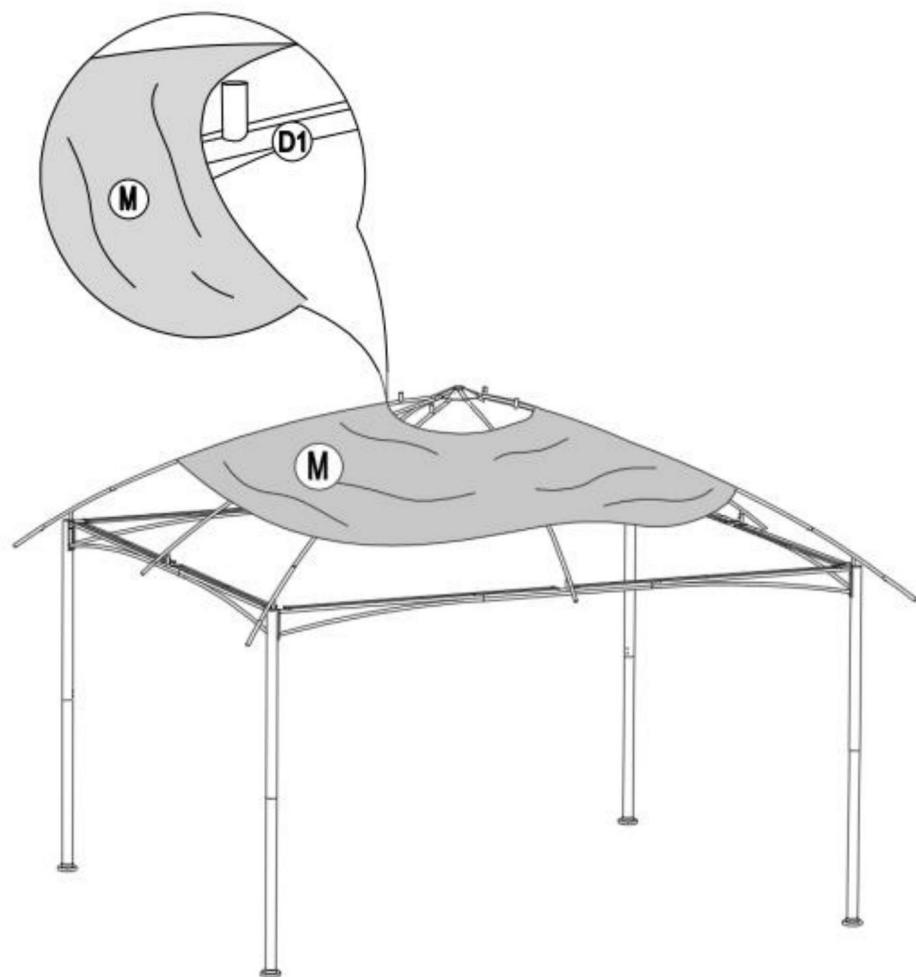
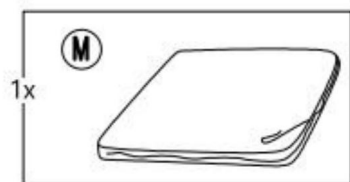

15

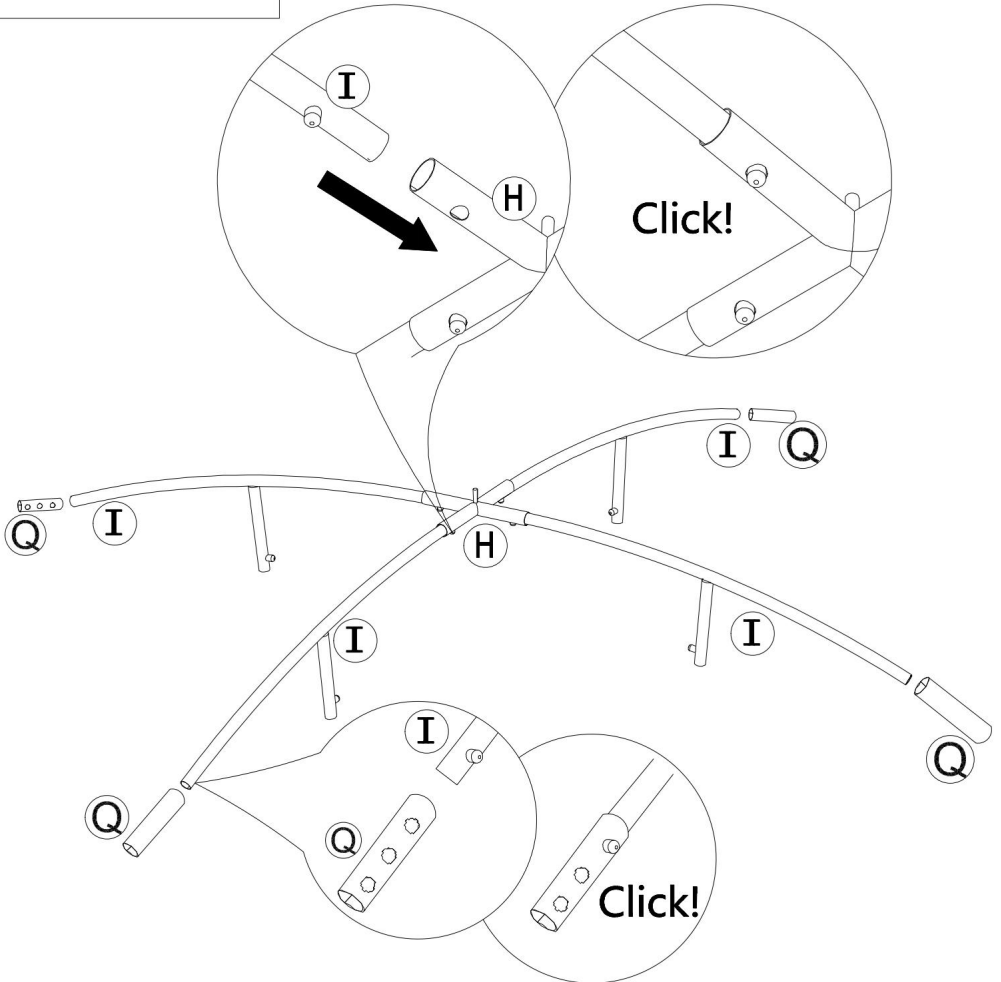
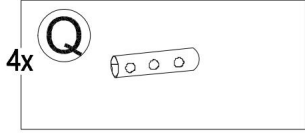
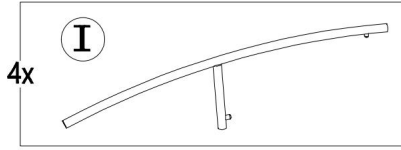
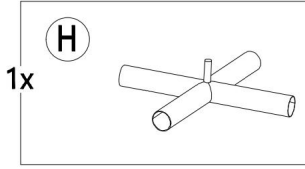

16

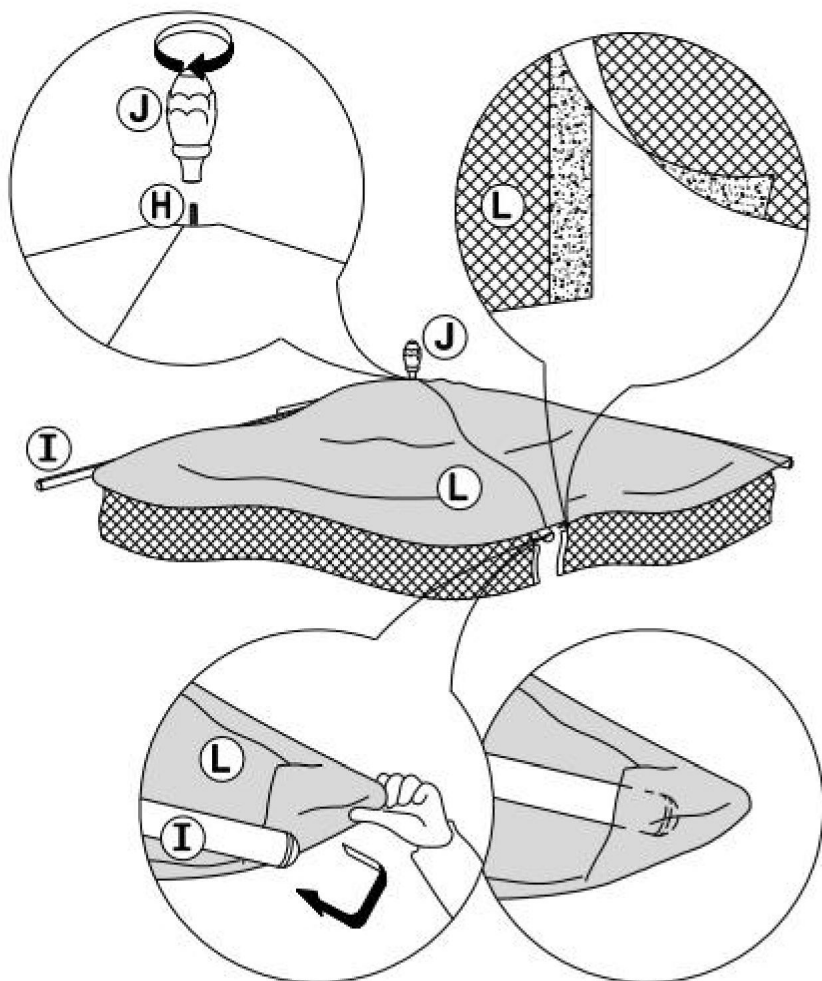
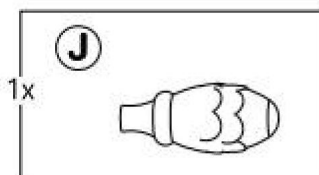
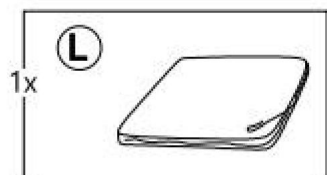

17

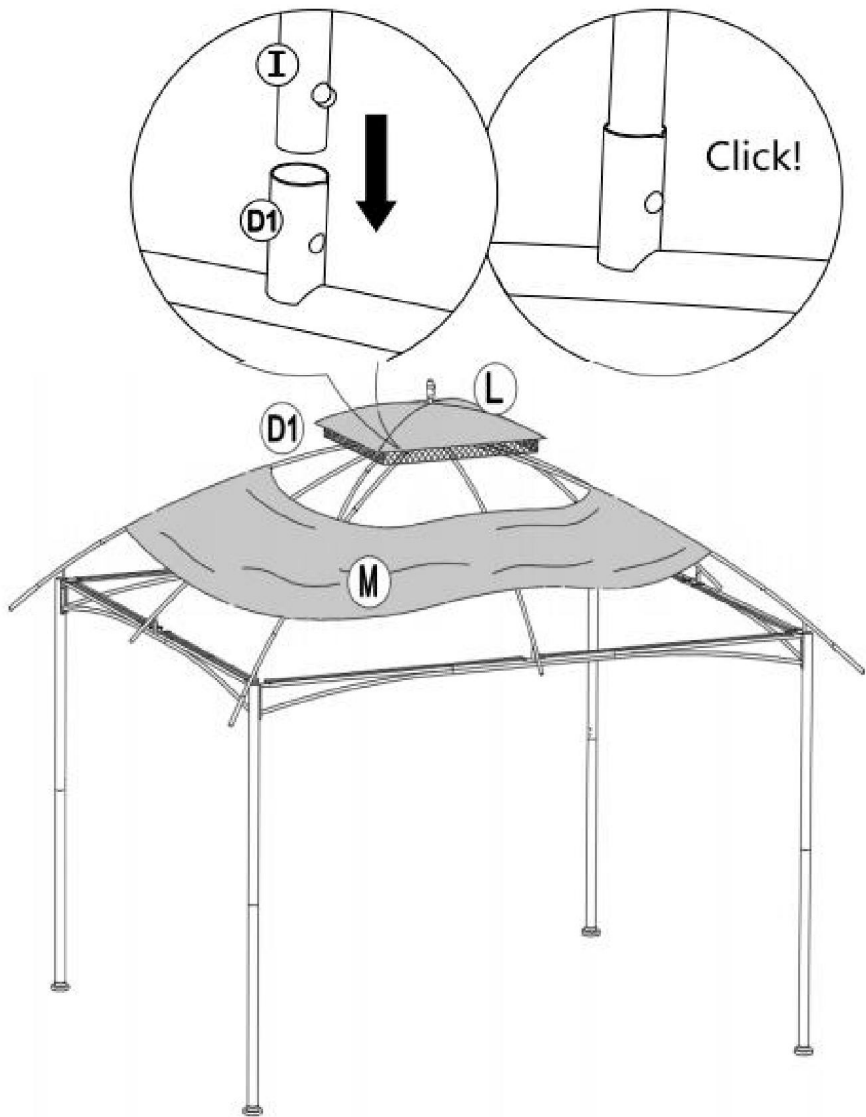

18

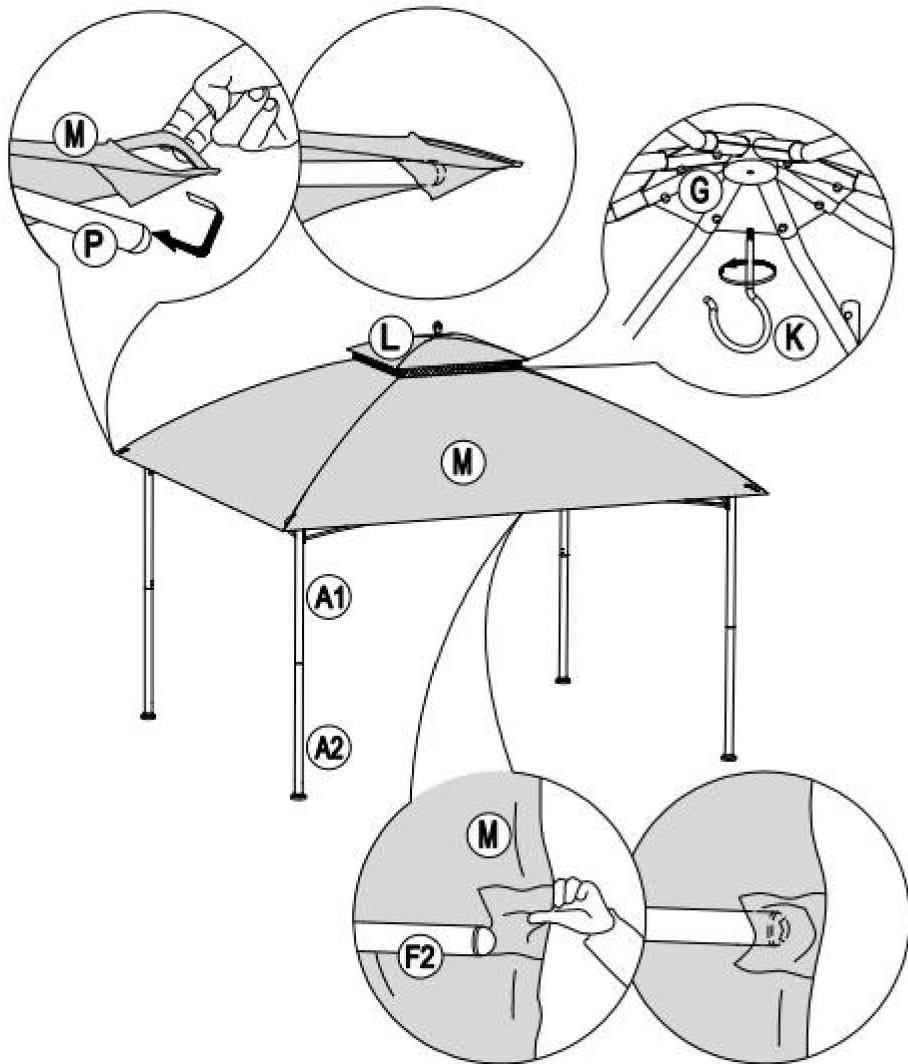
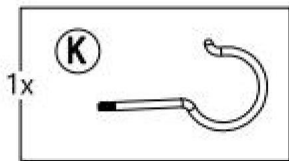

19

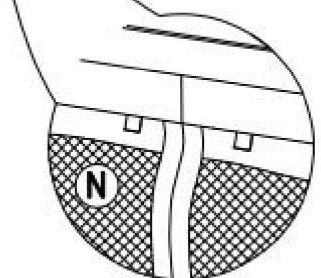
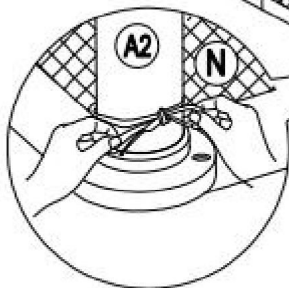
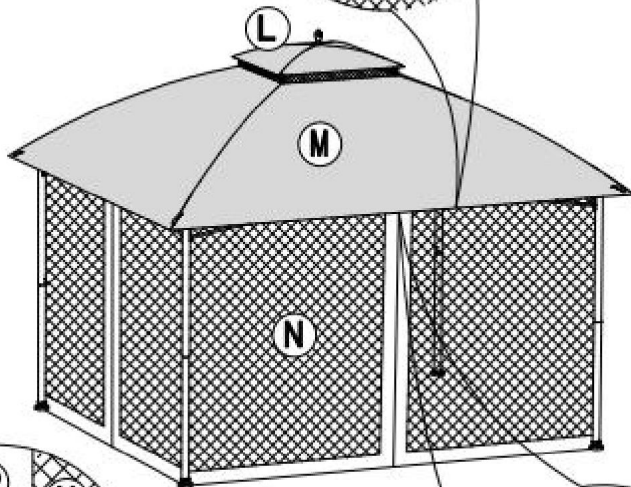
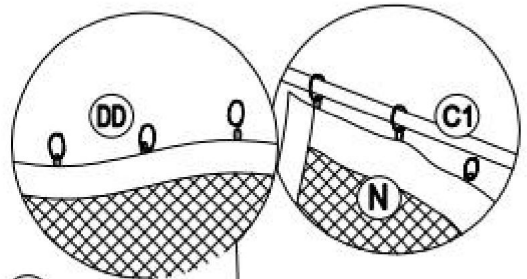
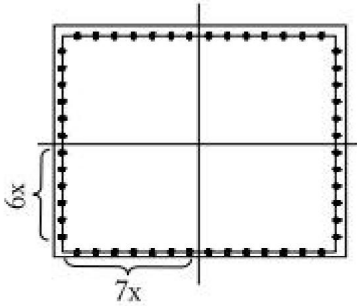
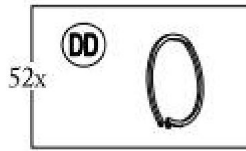
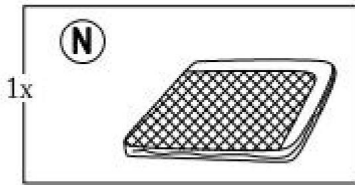

20

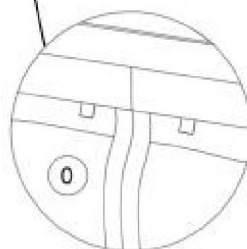
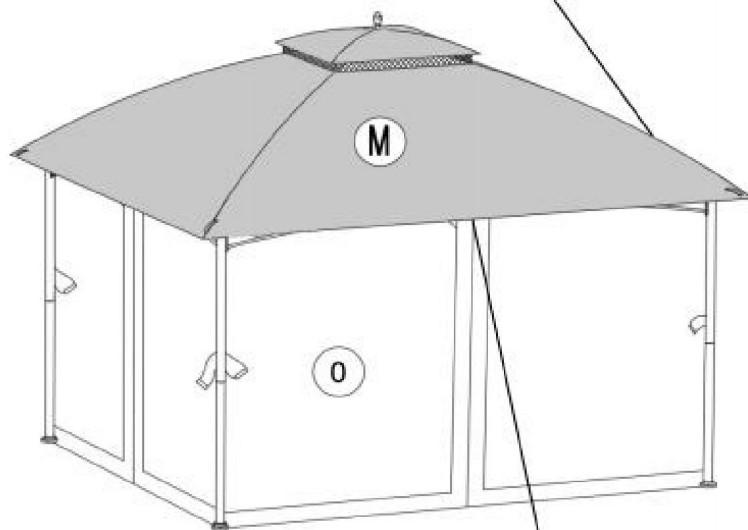
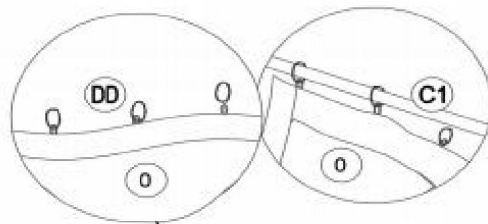
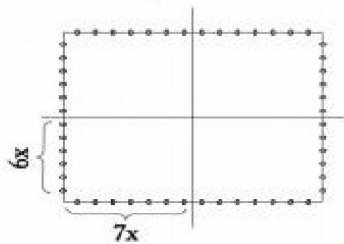
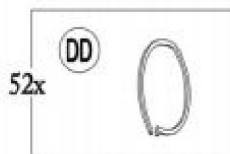
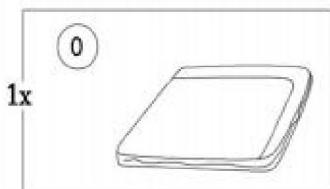

21

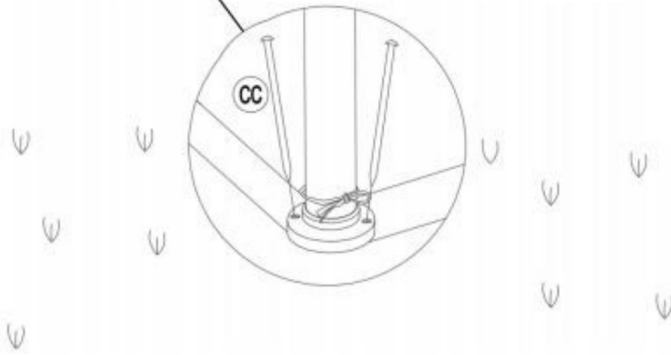
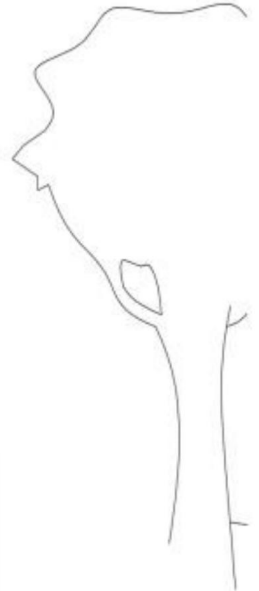
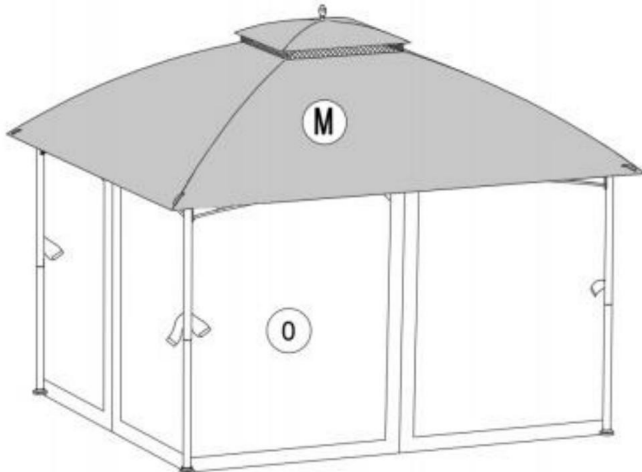

Importato negli USA: Sanven Technology Ltd.

Suite 250, 9166 Anaheim Place, Rancho Cucamonga, CA 91730

VEVOR®

TOUGH TOOLS, HALF PRICE

Supporto tecnico e certificato di garanzia
elettronica www.vevor.com/support

VEVOR®

TOUGH TOOLS, HALF PRICE

Wsparcie techniczne i certyfikat gwarancji elektronicznej www.vevor.com/support

INSTRUKCJA DOTYCZĄCA ALTAN PATIO

MODEL:KD-TY007-1

Nadal staramy się oferować Państwu narzędzia w konkurencyjnych cenach.

„Oszczędź połowę”, „Połowa ceny” lub inne podobne wyrażenia używane przez nas stanowią jedynie szacunkowe oszczędności, jakie możesz uzyskać, kupując u nas określone narzędzia w porównaniu z głównymi markami i niekoniecznie oznaczają one objęcie wszystkich kategorii oferowanych przez nas narzędzi. Uprzejmie przypominamy, aby przy składaniu zamówienia dokładnie sprawdzić, czy faktycznie oszczędzasz połowę w porównaniu z głównymi markami

VEVOR®

TOUGH TOOLS, HALF PRICE

ALTANY PATIO

KD-TY007-1

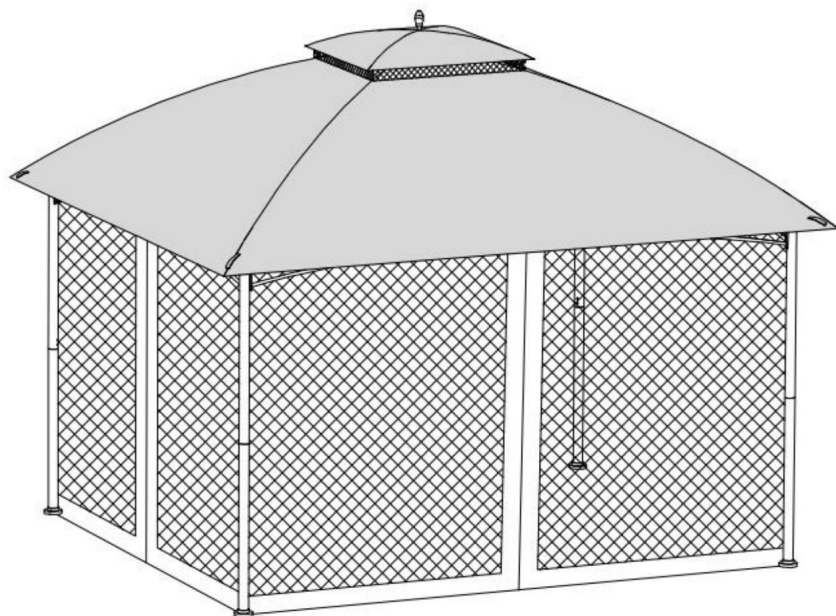

POTRZEBUJESZ POMOCY? SKONTAKTUJ SIĘ Z NAMI!

Masz pytania dotyczące produktu? Potrzebujesz wsparcia technicznego? Skontaktuj się z nami:

Wsparcie techniczne i certyfikat gwarancji elektronicznej www.vevor.com/support

To jest oryginalna instrukcja, przed użyciem należy uważnie przeczytać wszystkie instrukcje. VEVOR zastrzega sobie jasną interpretację naszej instrukcji obsługi. Wygląd produktu będzie zależał od produktu, który otrzymałeś. Prosimy o wybaczenie, że nie poinformujemy Cię ponownie, jeśli w naszym produkcie pojawią się jakiegokolwiek aktualizacje technologiczne lub oprogramowania.

INSTRUKCJA MONTAŻU I BEZPIECZEŃSTWA

Prosimy o dokładne zapoznanie się z poniższymi instrukcjami w celu zminimalizowania ryzyka obrażeń, wypadków lub uszkodzeń samego produktu.

WAŻNY

Proszę przestrzegać WSZYSTKICH instrukcji bezpieczeństwa wymienionych poniżej.

Przed montażem i użyciem produktu należy usunąć opakowanie.

Upewnij się, że wszystkie wymienione części znajdują się w opakowaniu i są nieuszkodzone.

Przed użyciem należy uważnie przeczytać niniejszą instrukcję montażu i bezpieczeństwa namiot i zachowaj go na przyszłość.

Produkt ten powinien być używany wyłącznie w celach niekomercyjnych.

INFORMACJE DOTYCZĄCE BEZPIECZEŃSTWA

Namiot nie był testowany pod kątem obciążeń wiatrem i śniegiem, chyba że wyraźnie wskazano inaczej. w przeciwnym razie. Dlatego też ładunki te nie są objęte gwarancją. Proszę obejrzeć prognozy pogody, aby móc odpowiednio zabezpieczyć lub zdemontować namiot przed pojawiają się problemy.

Namioty powinny być używane wyłącznie jako tymczasowe zakwaterowanie i powinny być: rozmontowywane w niesprzyjających warunkach atmosferycznych.

Należy zachować odpowiednią odległość od domów, a także linii gazowych i energetycznych. uniknąć możliwych uszkodzeń. Sprawdź obszar pod kątem kabli zasilających i przewodów gazowych. Jeśli to konieczne, zwróć się o dodatkowe informacje do lokalnych władz.

W przypadku stosowania odpowiednich grzejników należy zachować minimalną odległość 1,2 m od plandeki. materiał. Otwarty ogień lub grzejniki z otwartym płomieniem, takie jak grzejniki tarasowe, parasole. W żadnym wypadku nie wolno używać wewnątrz namiotu grzejników, piecyków gazowych itp.

Osoba odpowiedzialna za budowę namiotu jest odpowiedzialna za jego należyte zabezpieczając go, aby zapewnić jego bezpieczeństwo. Proszę stale sprawdzać zakotwiczenie, aby uniknąć uszkodzenia. Stabilne zakotwiczenie może wydłużyć wytrzymałość namiotu.

Aby zapewnić sobie bezpieczeństwo, pamiętaj o założeniu rękawiczek. Części metalowe mogą mieć ostre krawędzie i mogą być tłuste z powodu rdzy. Leczenie zapobiegawcze.

Upewnij się, że nie ma stałego obciążenia śniegiem. Należy go usunąć natychmiast. To samo dotyczy deszczu i innych form obciążenia.

Ostrzeżenie - proszę trzymać plastik i małe części zamienne poza zasięgiem dzieci. cienka warstwa może przykleić się do nosa i ust, uniemożliwiając oddychanie.

MONTAŻ I UŻYTKOWANIE

Proszę zarezerwować sobie trochę więcej czasu na pierwszą instalację namiotu. Zasady, które należy przestrzegać podczas rozstawiania namiotu są proste. Proszę skorzystać z instrukcji ilustracyjnych na każdym etapie instalacji.

Śruby łączące rury z łącznikami należy dokręcać ręcznie, przy użyciu klucza imbusowego lub automatycznego śrubokrętu ustawionego na maks. poziomie 2, aby uniknąć uszkodzenia materiału nosić.

Namiot powinien być montowany wyłącznie przez co najmniej dwie osoby dorosłe. Prosimy, aby dzieci nie były w pobliżu. z dala od namiotu podczas jego rozkładania, aby je chronić.

Upewnij się, że znajdziesz płaską i równą podstawę, która będzie odpowiednia dla montażu produktu i jego przeznaczenia.

Należy używać wyłącznie materiałów dostarczonych wraz z namiotem w momencie dostawy.

Plandeki nie powinny stykać się z żadnymi przedmiotami o ostrych krawędziach.

Namiot można używać w temperaturach bliskich zera. Jednak przed takimi użytkowaniem, materiał plandeki musi być przechowywany w temperaturze co najmniej 10°C. Proszę upewnić się, że plandeka nie rozerwie się podczas składania.

W każdym kraju obowiązują różne przepisy dotyczące konstrukcji ruchomych (namiotów) i nieruchome konstrukcje. Proszę zapytać lokalne władze, czy pozwolenie należy uzyskać, aby rozbić namiot. W niektórych krajach zależy to od rozmiaru namiot.

INSTRUKCJE DOTYCZĄCE PIELĘGNACJI I PRZECHOWYWANIA

Żadne szkody powstałe na skutek działania sił natury (szkody pogodowe) nie są objęte gwarancją. Namiot można używać w temperaturach bliskich zera. Jednak przed takimi użytkowaniem, materiał plandeki musi być przechowywany w temperaturze co najmniej 10°C. Proszę upewnić się, że plandeka nie rozerwie się podczas składania.

Silne wiatry mogą uszkodzić produkt. Prosimy nie opuszczać altany bez nadzoru przez dłuższy czas.

Narażenie na działanie promieni słonecznych może spowodować blaknięcie koloru plandeki. Nie ma to wpływu na użyteczność paleniska i nie jest uznawane za wadę produktu.

Ulewne lub długotrwałe opady deszczu mogą powodować gromadzenie się wody na dachu. Te kieszenie należy usunąć możliwie jak najszybciej.

Proszę nie używać agresywnych środków chemicznych do czyszczenia materiału plandeki. Najlepiej środkiem czyszczącym jest woda o odczynie lekko zasadowym.

Nie należy dokonywać żadnych modyfikacji metalowej konstrukcji namiotu, np. na przykład łączenie i/lub spawanie dodatkowych obciążeń, wykonywanie rowków i/lub deformacje.

Aby uniknąć uszkodzeń, należy zdjąć plandekę, jeśli produkt nie jest używany.

Zalecamy demontaż pawilonu w przypadku złych warunków atmosferycznych oraz sezon zimowy.

Namiot/plandekę należy składać, pakować i przechowywać wyłącznie po całkowitym wyschnięciu. Prosimy o Podczas przechowywania nie należy kłaść żadnych innych przedmiotów na namiocie/plandece.

SPECYFIKACJE

Model	KD-TY007-1
Product Size	2970×3920×3530mm
Color	Beige/Brown/Black

NARZĘDZIA

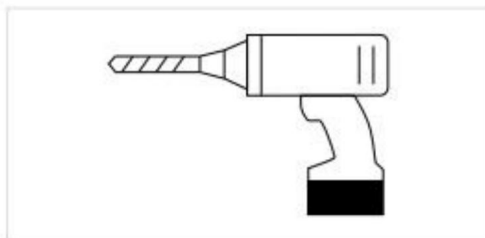





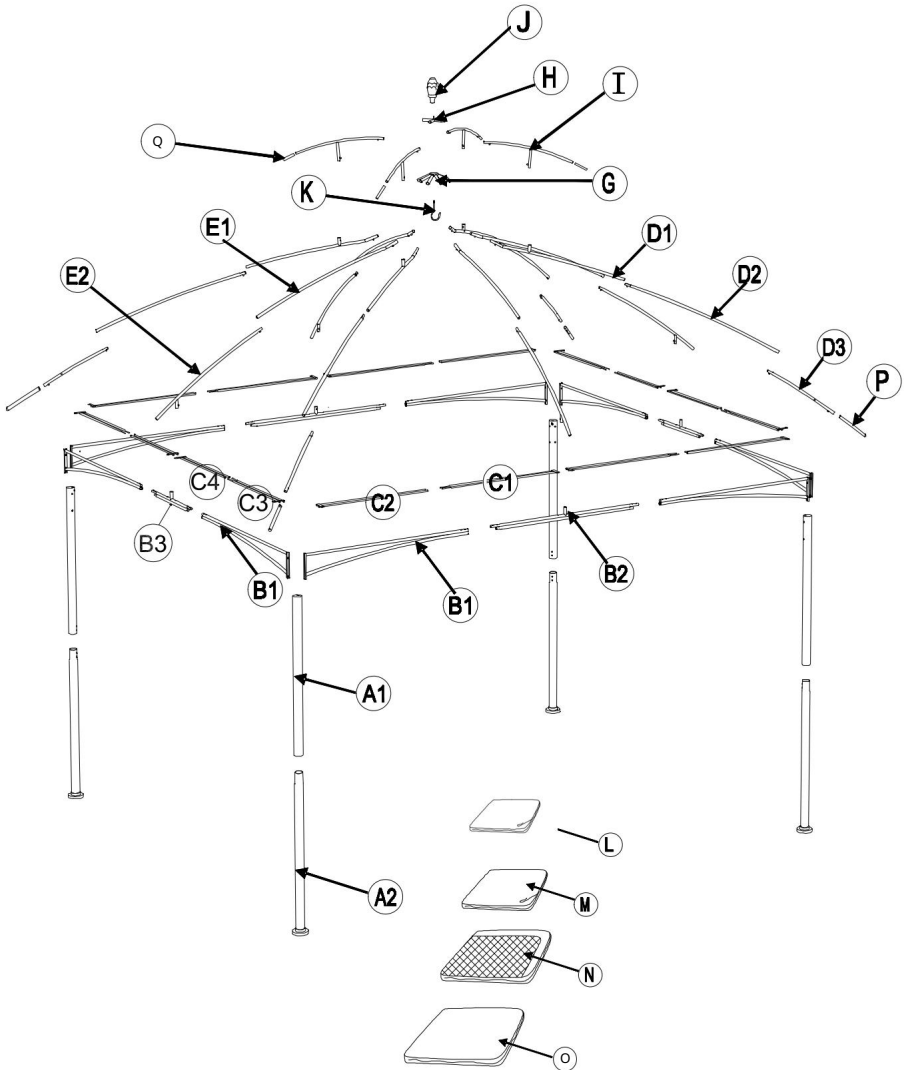
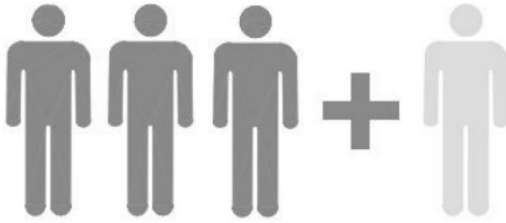





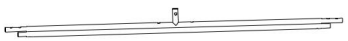
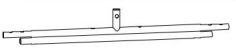













IMPORTANT





People needed for installation work

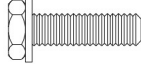
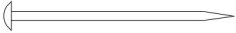

Parts List

Label	Qty	Part Image
A1	4	
A2	4	
B1	8	
B2	2	
B3	2	
C1	4	
C2	4	
C3	4	
C4	4	
D1	4	
D2	4	
D3	4	
E1	2	
E2	2	
F1	2	
F2	2	
G	1	
H	1	

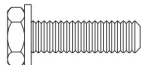
Parts list		
Label	Qty	Parts Image
I	4	
J	1	
K	1	
L	1	
M	1	
N	1	
P	4	
O	1	
Q	4	

Parts list				
Label	Description	Qty	Add	Parts Image
AA	M5*15	24	2	
BB	M6*20	40	2	
CC	Φ8*180	8	0	
DD	/	104	3	
EE	M5/M6	1	0	
FF	M6*35	4	1	
GG	M6	4	1	

1

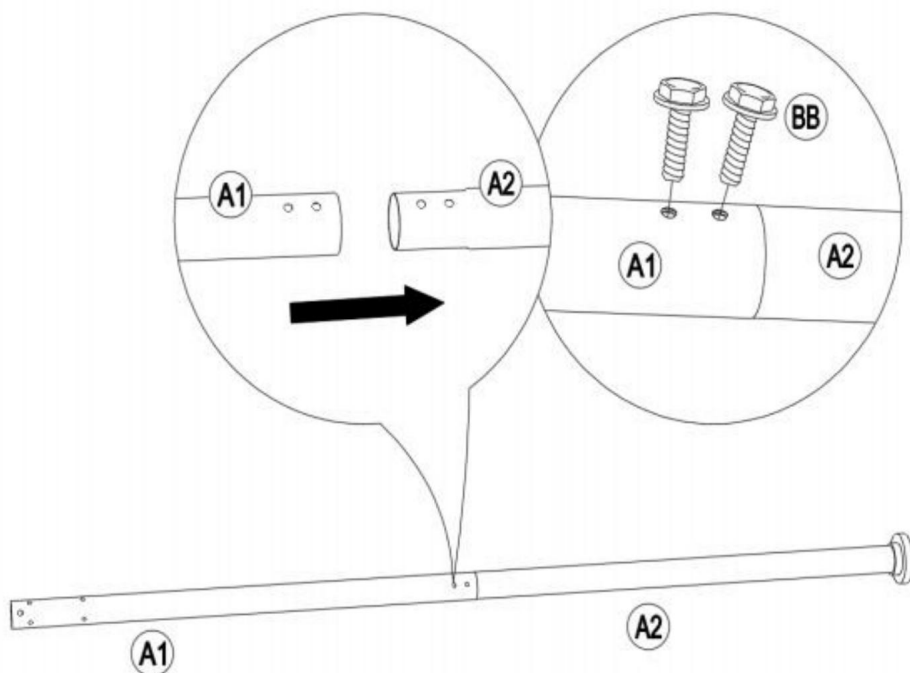
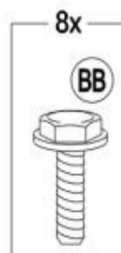
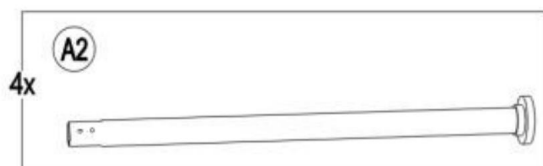

2

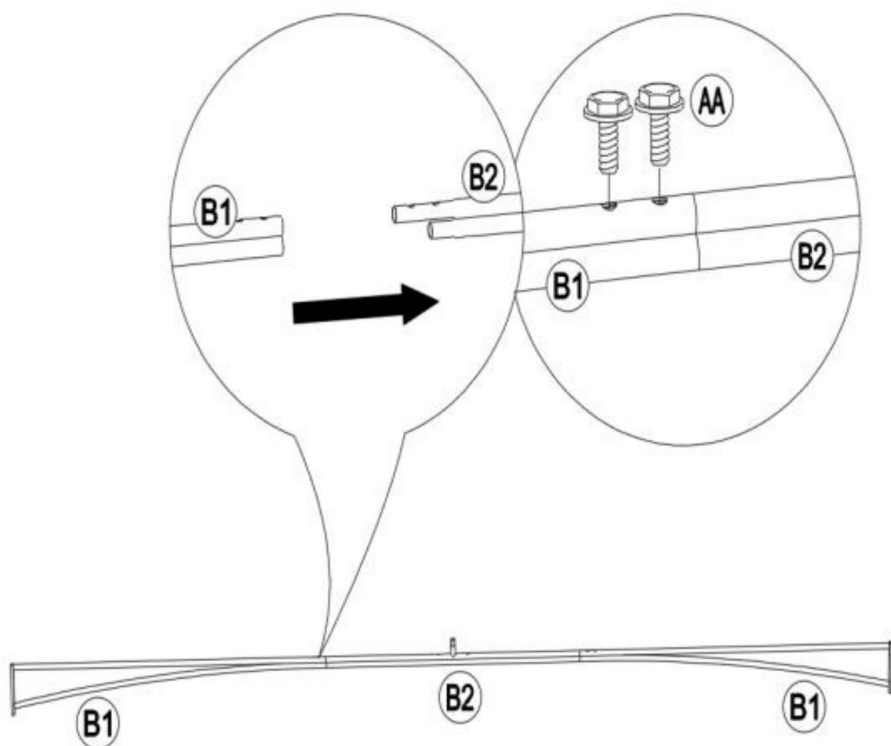
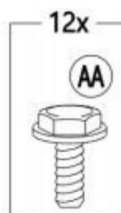
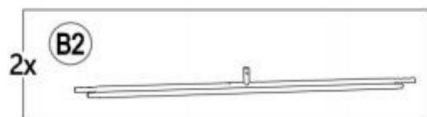
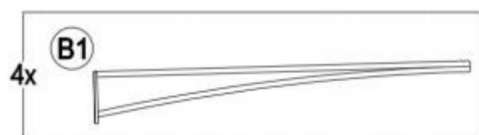

3

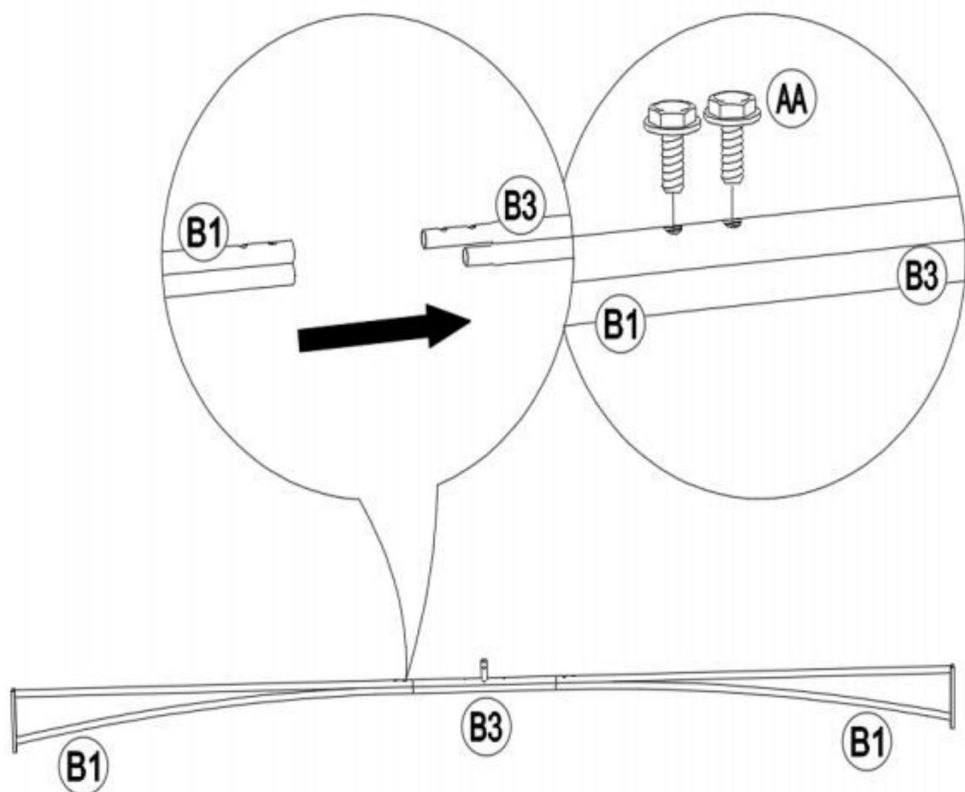
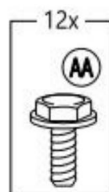
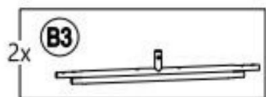
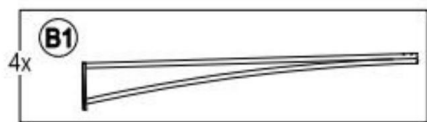

4

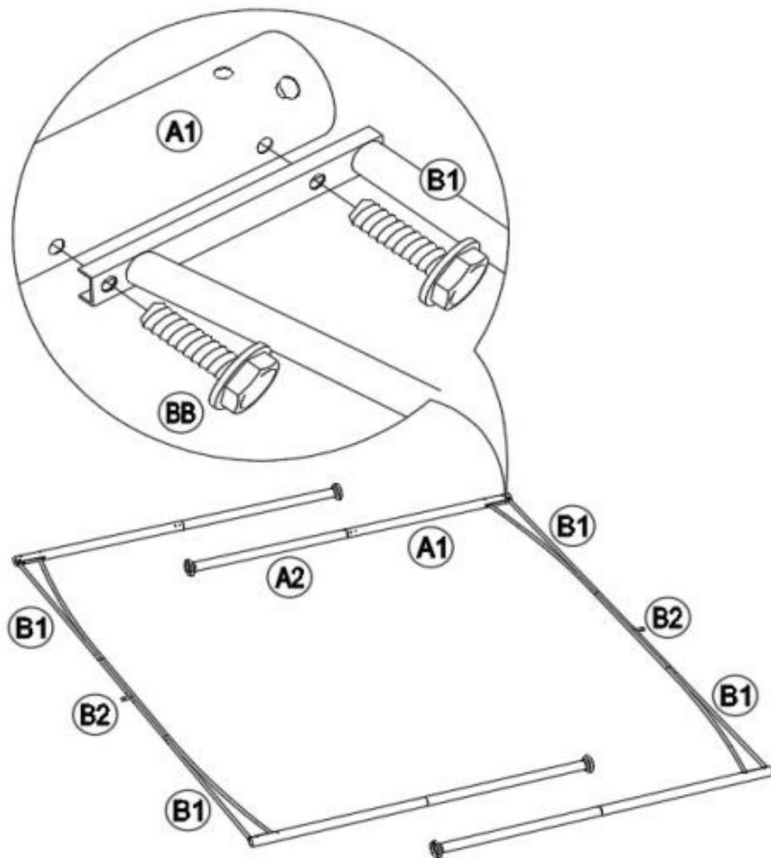
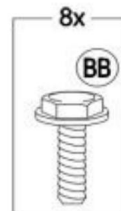
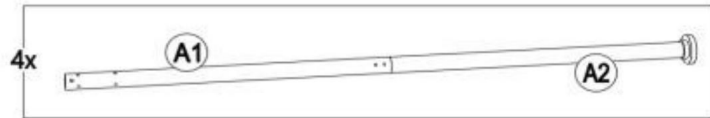
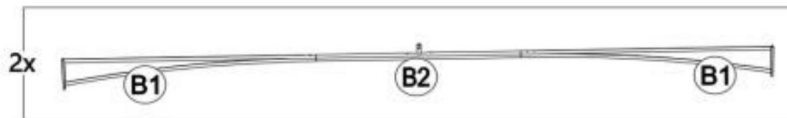

5

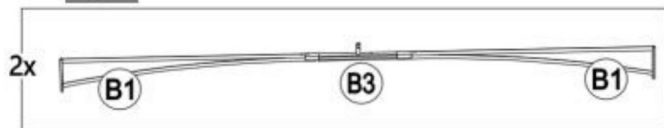

8x

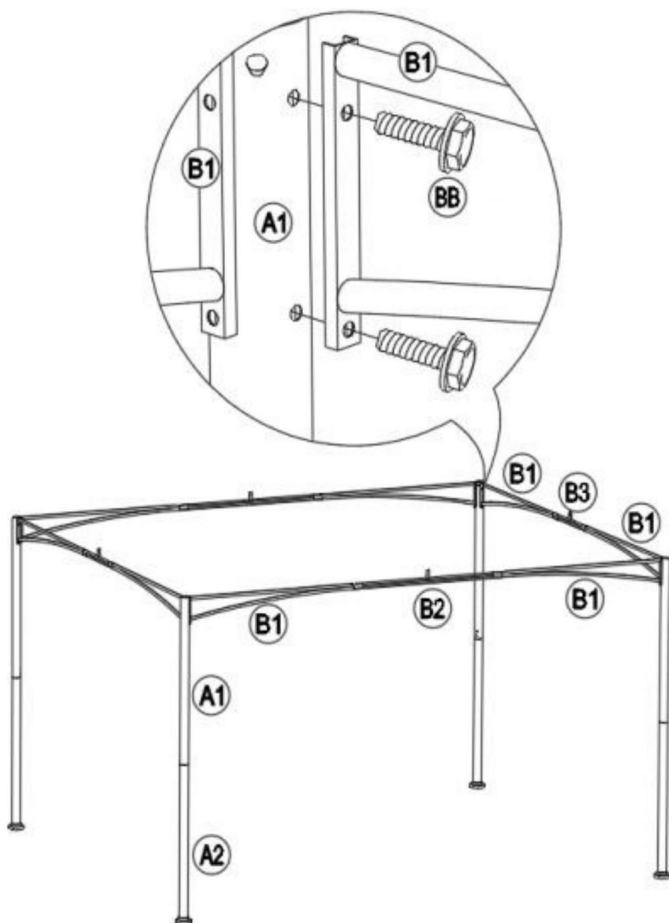
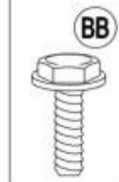

6

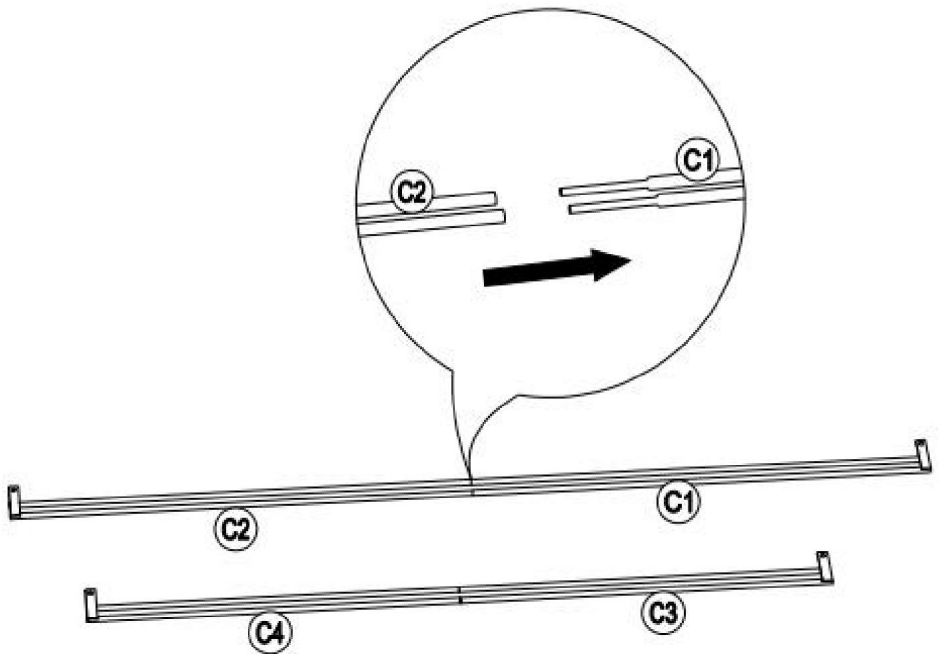

7

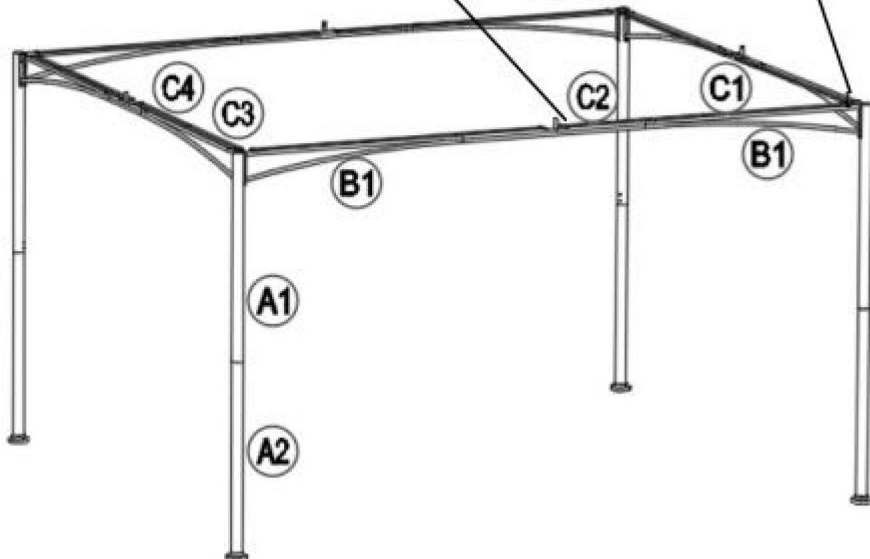
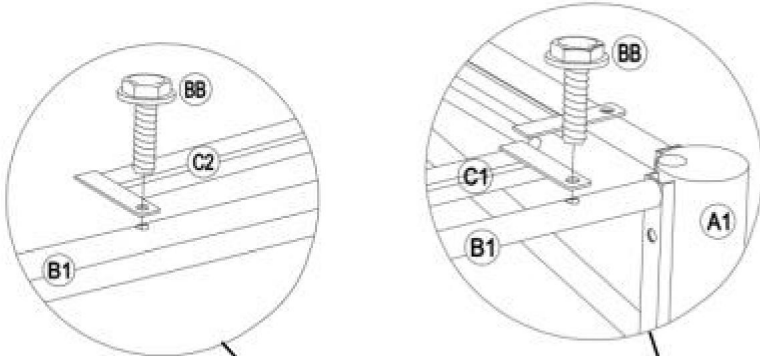
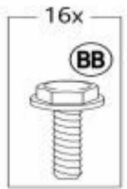

8

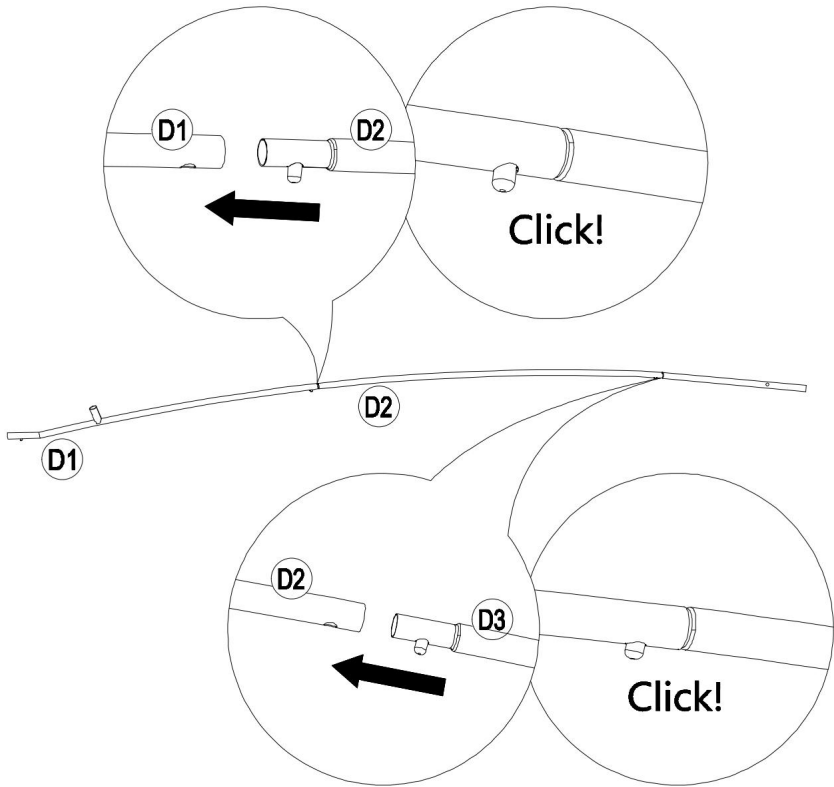
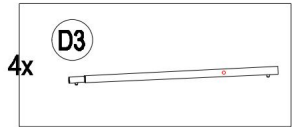
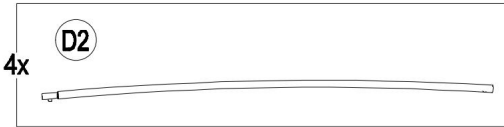
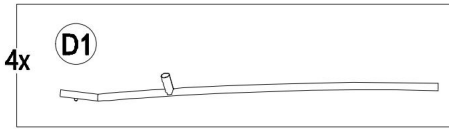

9

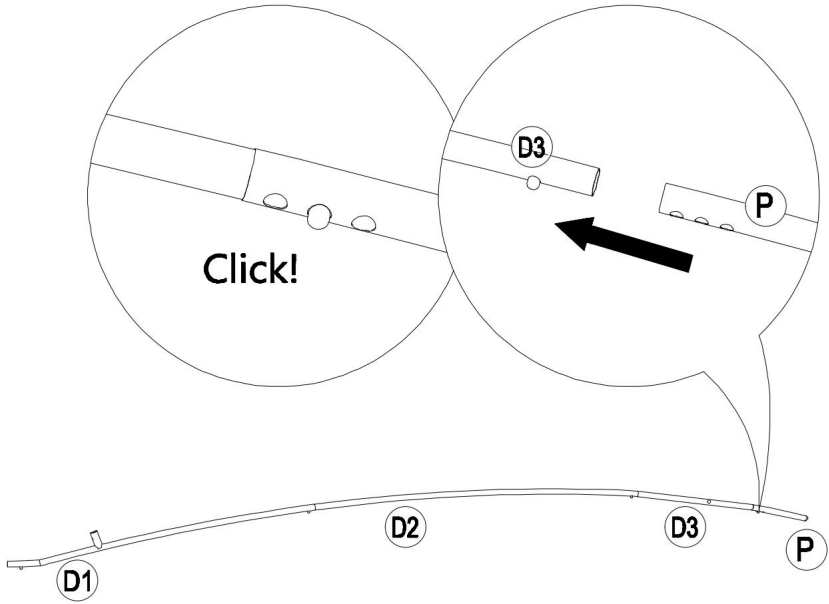
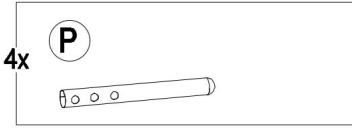

10

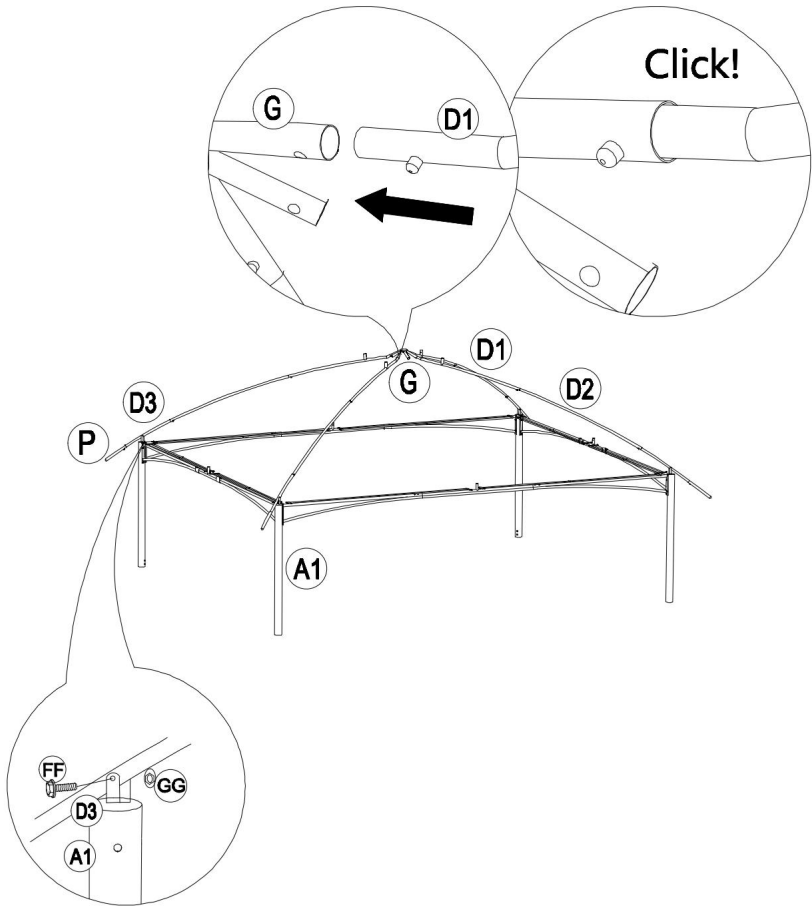
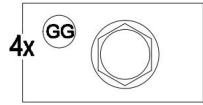
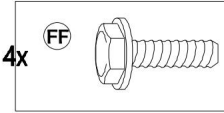
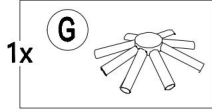
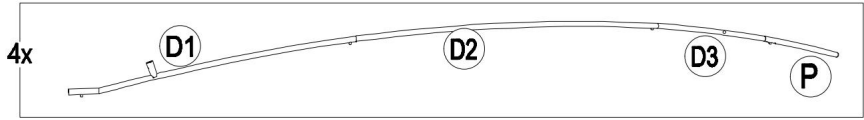

11

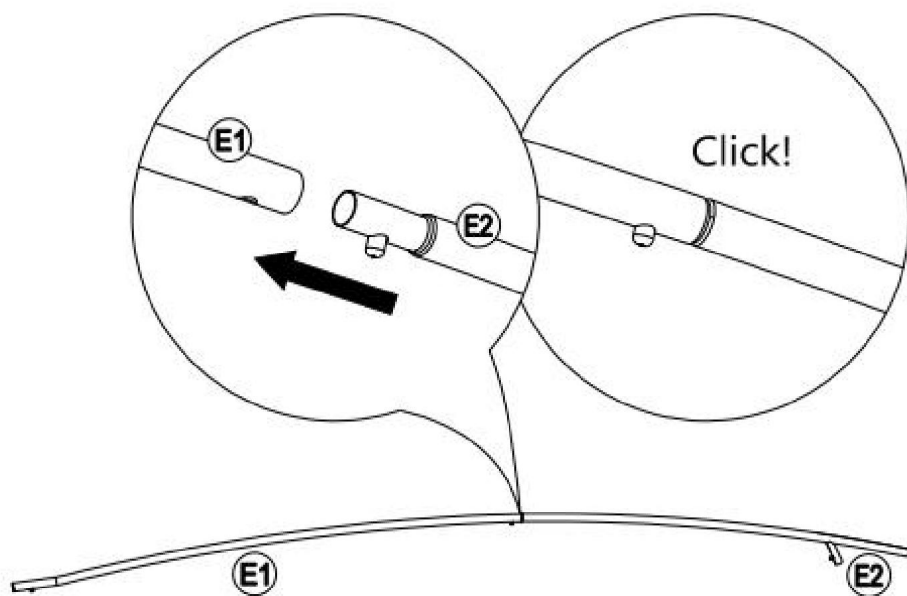
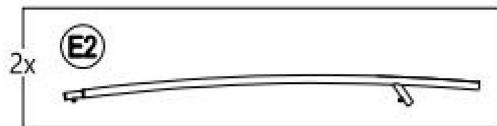

12

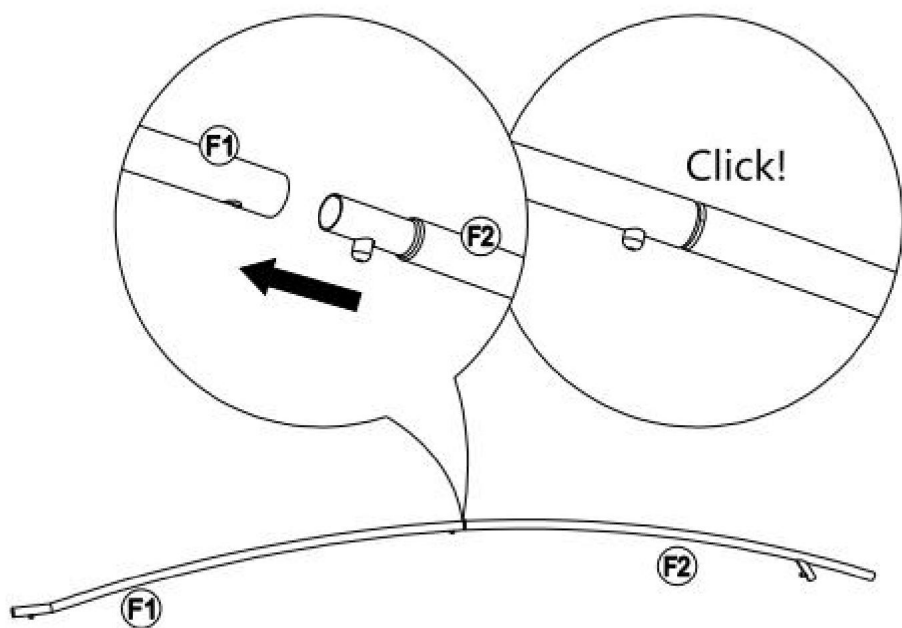
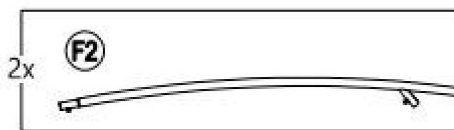
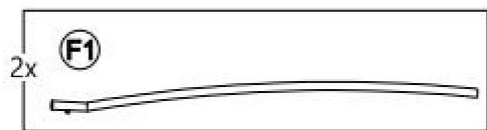

13

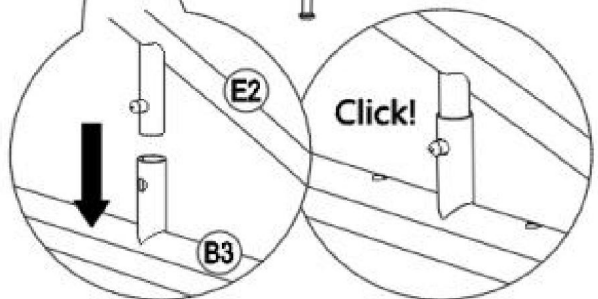
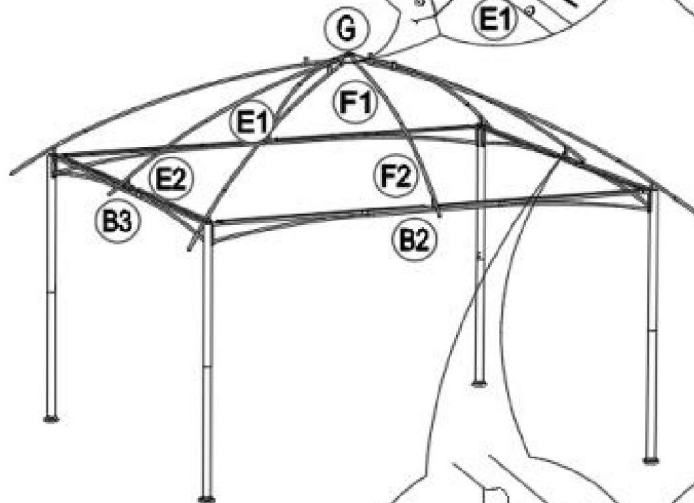
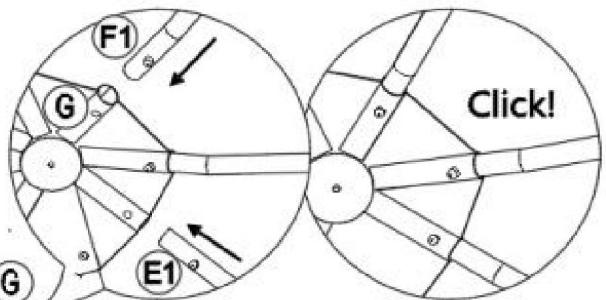
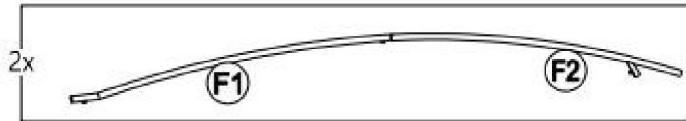

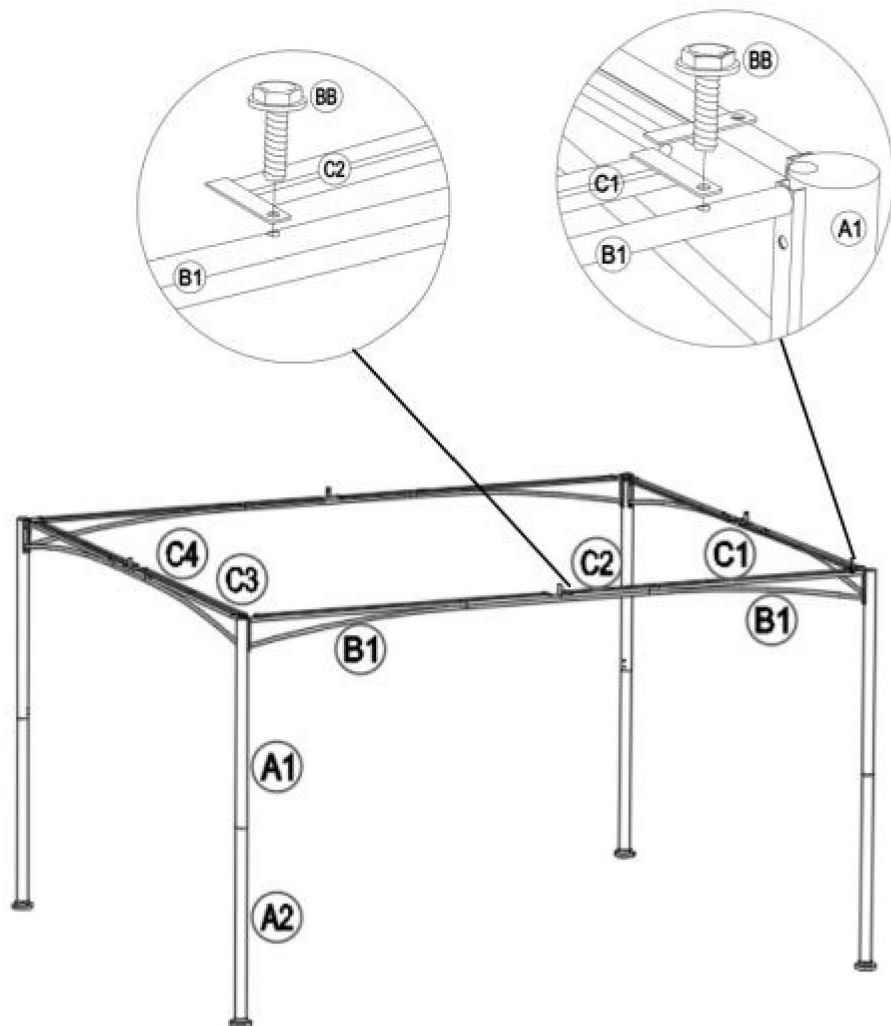

14

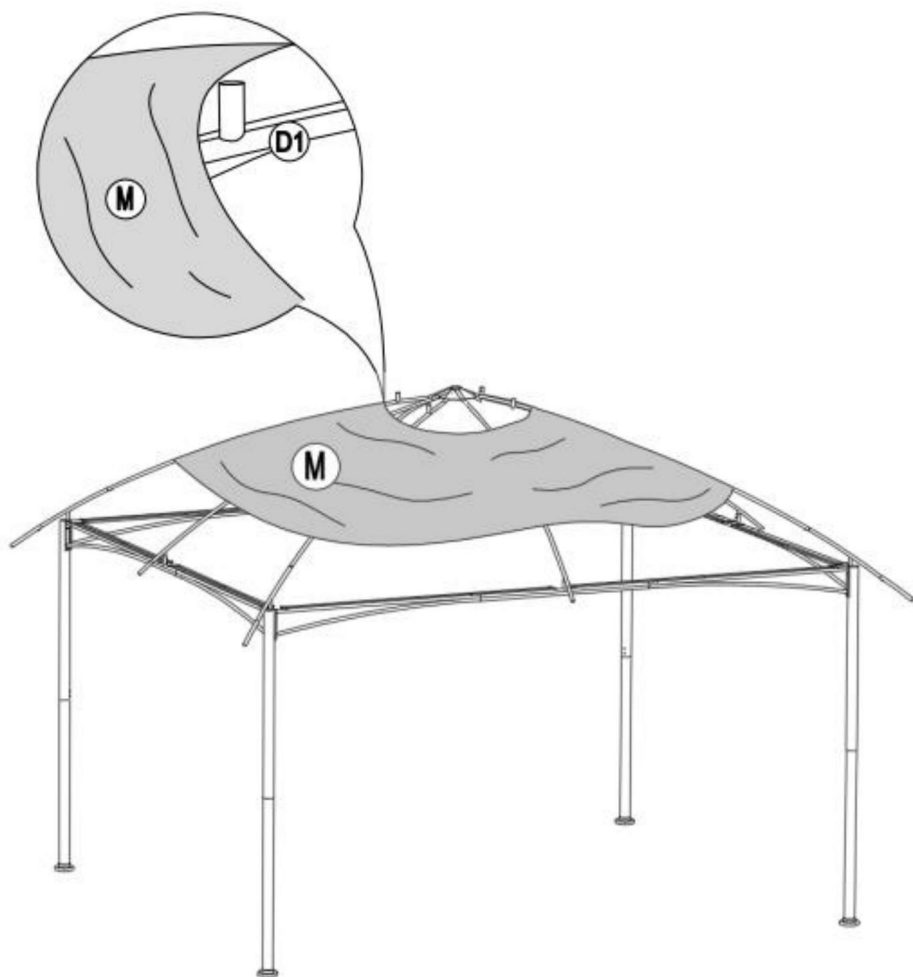
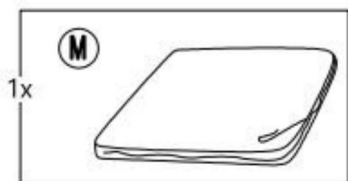

15

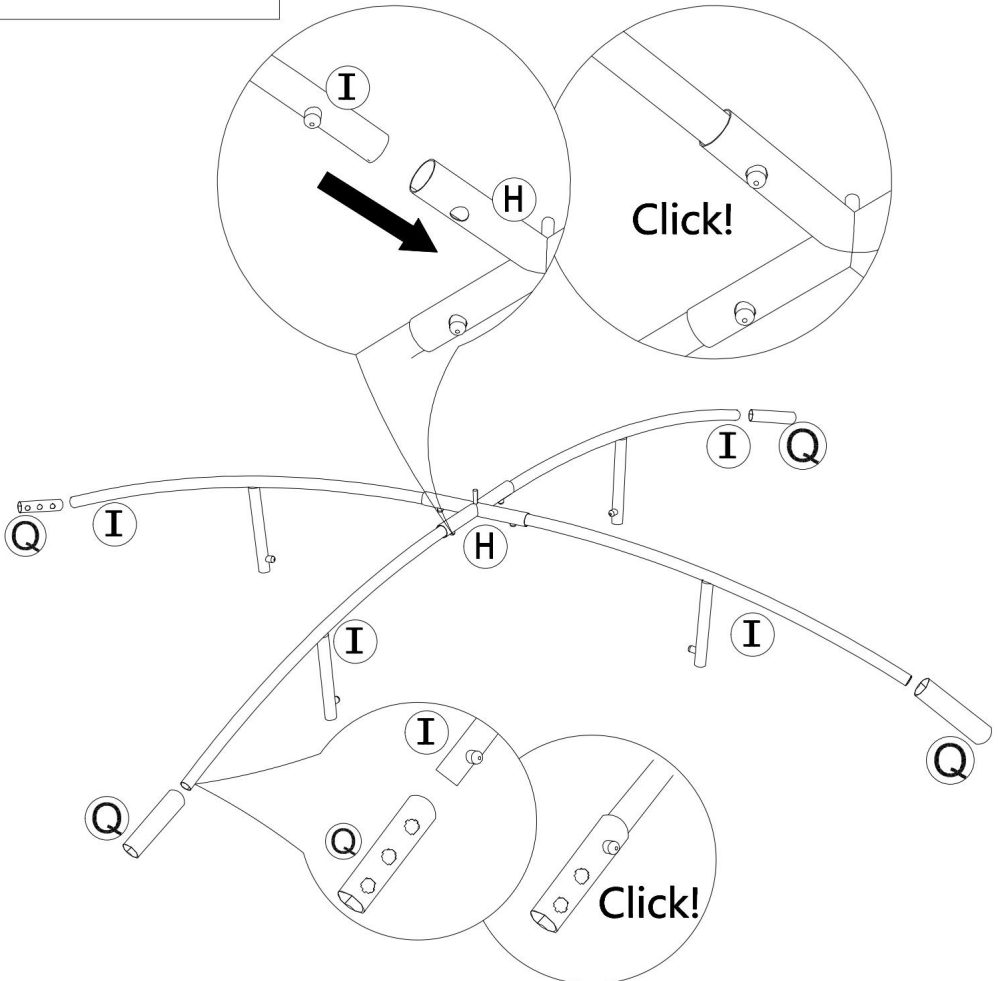
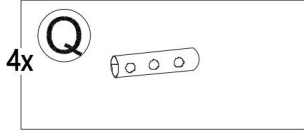
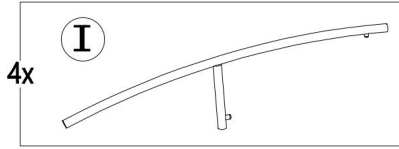
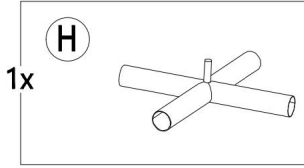

16

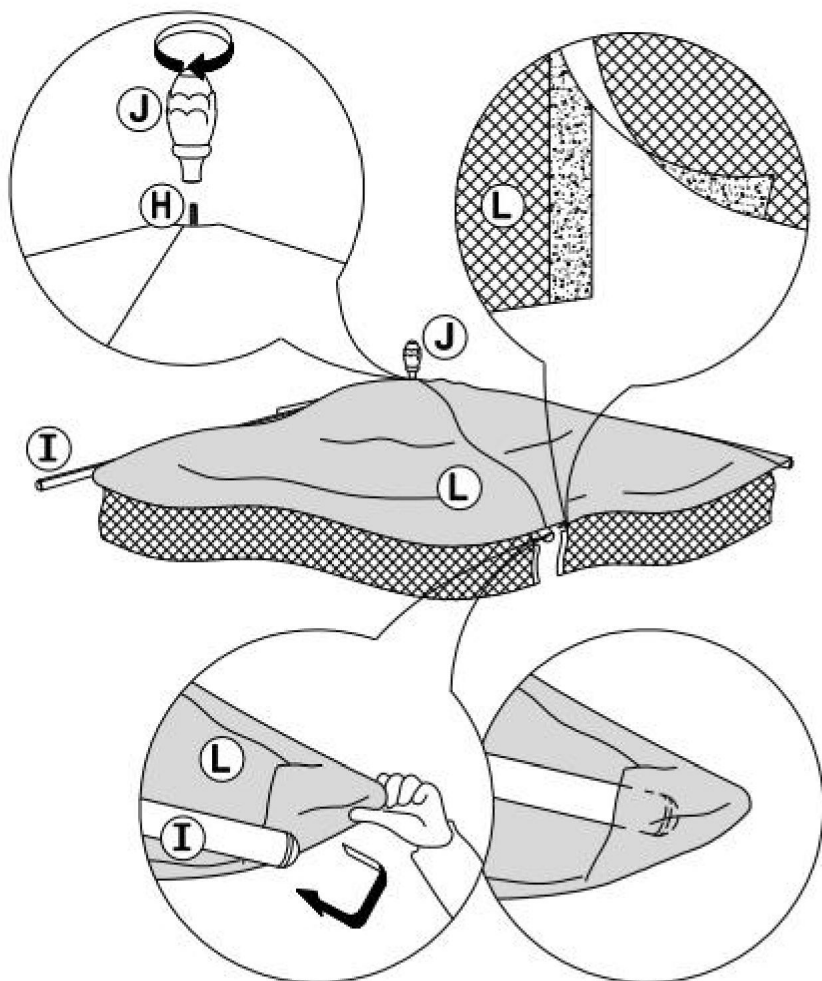
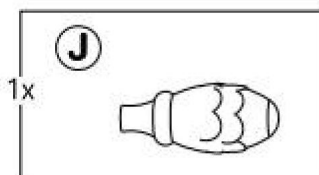
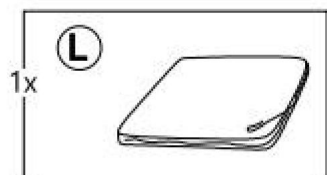

17

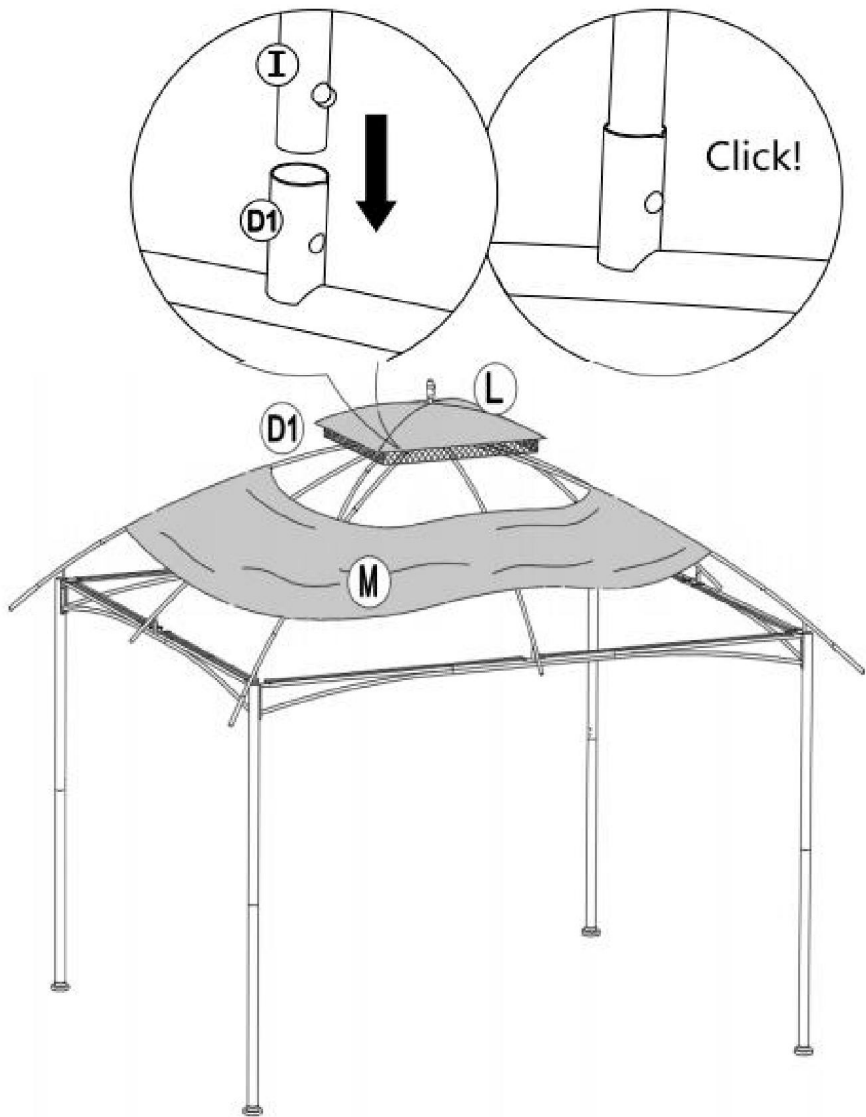

18

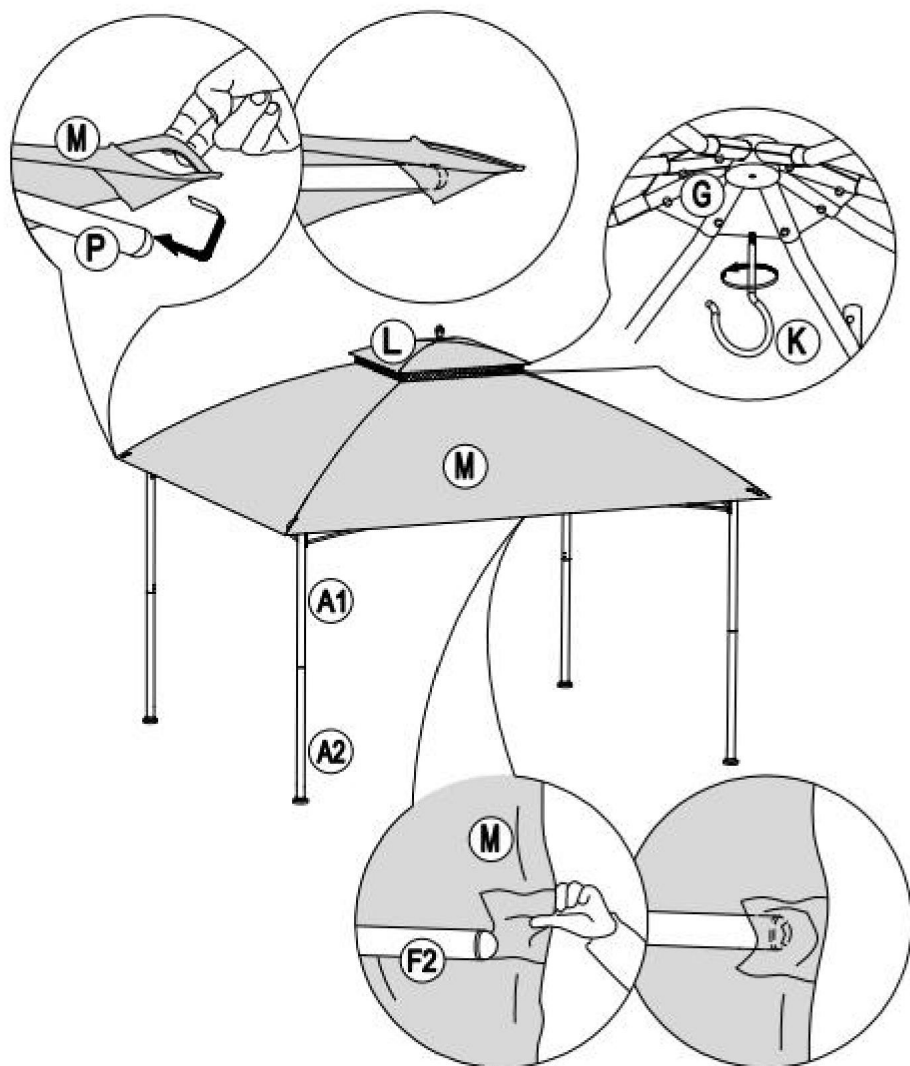
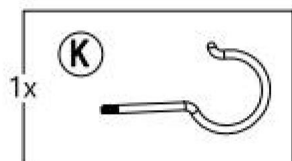

19

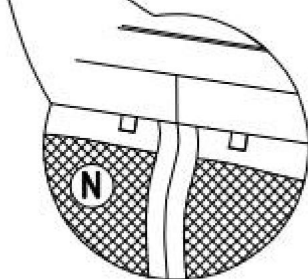
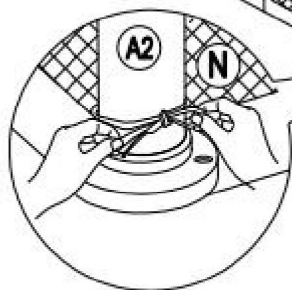
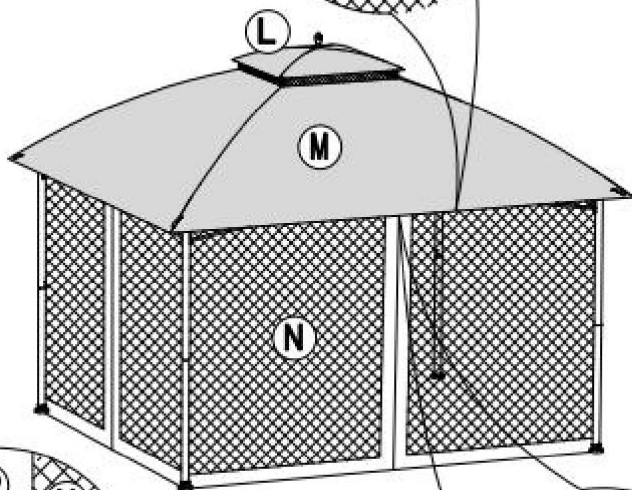
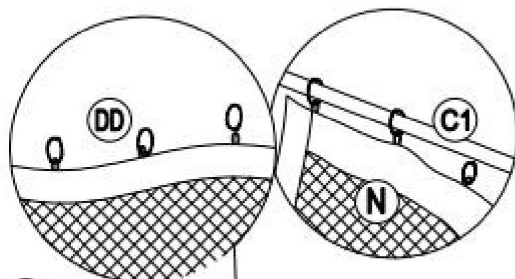
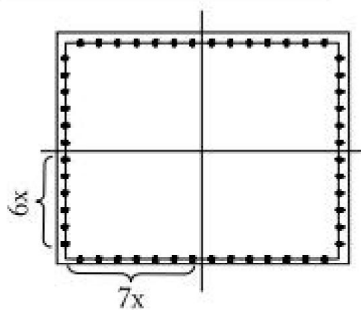
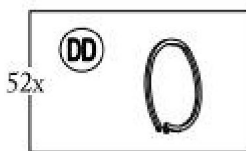
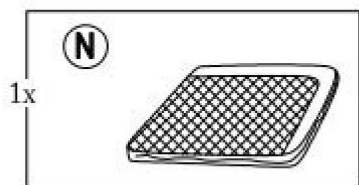

20

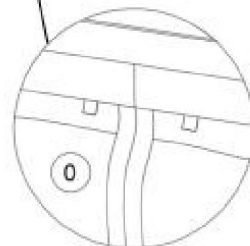
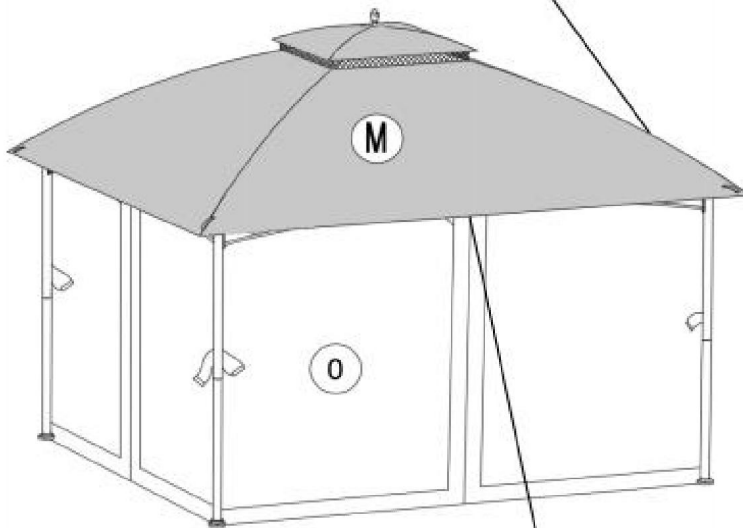
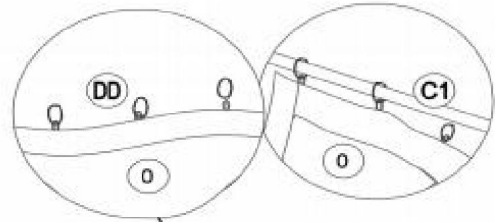
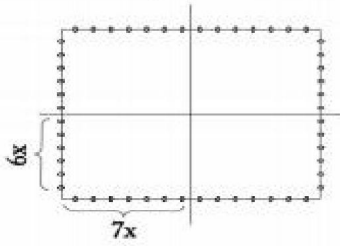
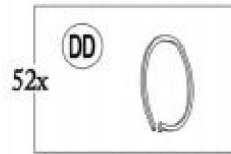
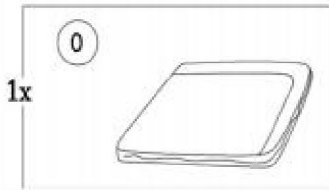

21

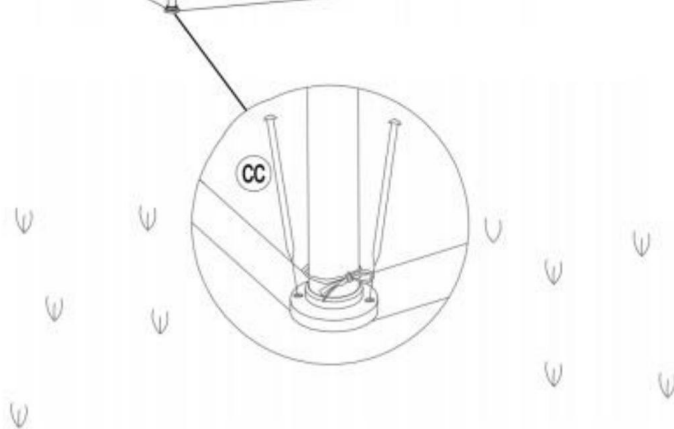
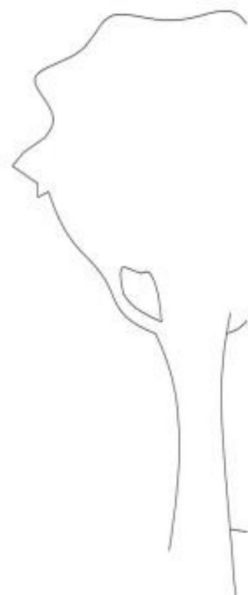
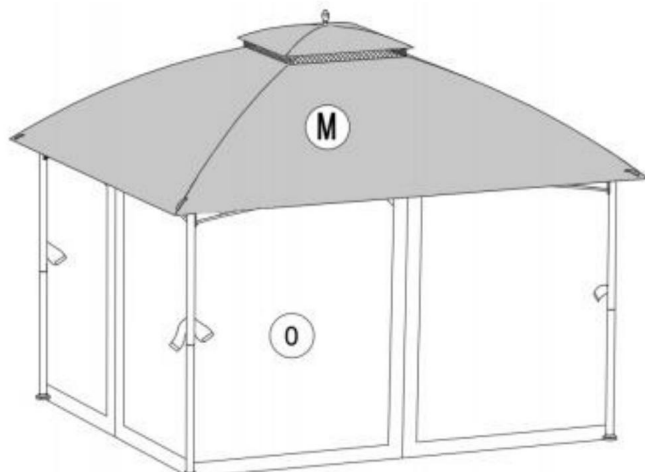

Importowane do USA: Sanven Technology Ltd.

Apartament 250, 9166 Anaheim Place, Rancho Cucamonga, CA 91730

VEVOR®

TOUGH TOOLS, HALF PRICE

Wsparcie techniczne i certyfikat gwarancji
elektronicznej www.vevor.com/support