

VEVOR[®]

TOUGH TOOLS, HALF PRICE

Technical Support and E-Warranty Certificate

www.vevor.com/support

MOBILE BASE

MODEL: GZB88094

We continue to be committed to provide you tools with competitive price.

"Save Half", "Half Price" or any other similar expressions used by us only represents an estimate of savings you might benefit from buying certain tools with us compared to the major top brands and does not necessarily mean to cover all categories of tools offered by us. You are kindly reminded to verify carefully when you are placing an order with us if you are actually saving half in comparison with the top major brands.

VEVOR[®]

TOUGH TOOLS, HALF PRICE

MOBILE BASE

MODEL: GZB88094



Photo for reference

NEED HELP? CONTACT US!

Have product questions? Need technical support? Please feel free to contact us:

Technical Support and E-Warranty Certificate
www.vevor.com/support

This is the original instruction, please read all manual instructions carefully before operating. VEVOR reserves a clear interpretation of our user manual. The appearance of the product shall be subject to the product you received. Please forgive us that we won't inform you again if there are any technology or software updates on our product.

SAFETY INSTRUCTIONS



WARNING: Read and understand this manual before assembling, installing, operating, or servicing this product. Failure to follow these warnings and instructions can cause death, personal injury, or damage to valuable property.

1. Please do not put it near flammable materials.
2. It is forbidden to carry people under any condition.
3. This product cannot be used to go up or down stairs.
4. Overload is strictly prohibited.
5. Don't move too fast when passing pothole areas.

SAVE THESE INSTRUCTIONS

MODEL AND PARAMETERS

Material: Q235

Product size: Minimum 18x24 inches, maximum 26.5x31.5 inches

Load capacity: 1500 lbs max.

Note: When adjusting the mobile base to the maximum installation size, it cannot be used with the maximum load capacity.

Part list:

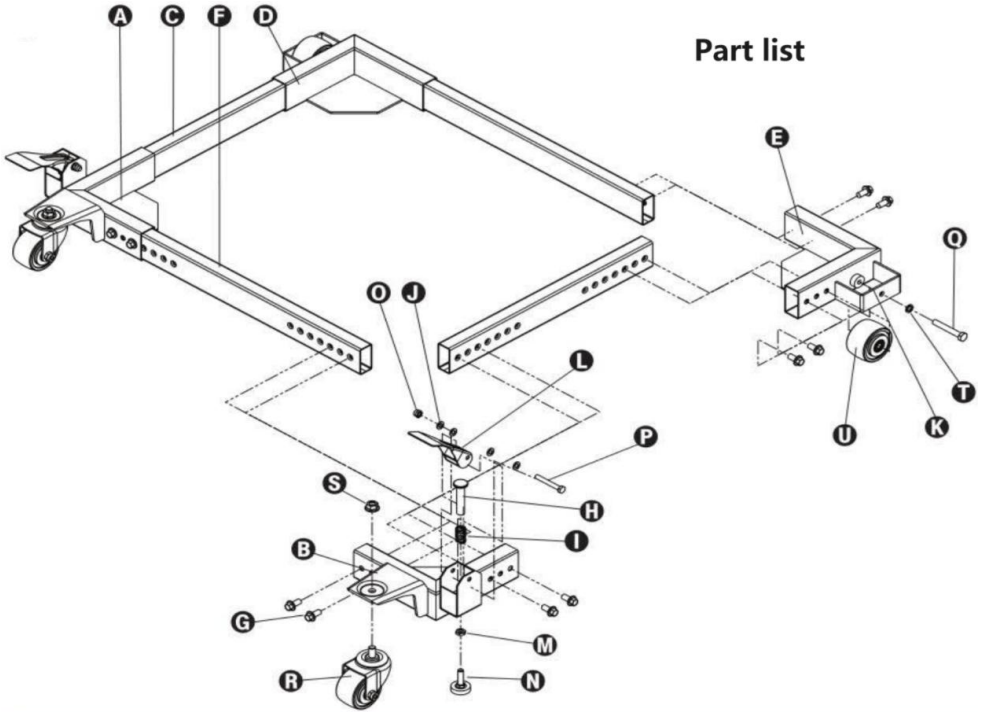

Part list

Parts List					
S/N	Description	Qty	S/N	Description	Qty
Ⓐ	Front Left Corner	1	Ⓕ	Foot Lever	2
Ⓑ	Front Right Corner	1	Ⓜ	M10 Jam Nut	2
Ⓒ	Short Side Tube	2	Ⓝ	Rubber Glide Foot	2
Ⓓ	Rear Left Corner	1	Ⓖ	M8 Nyloc Nut	2
Ⓔ	Rear Right Corner	1	Ⓟ	8x60-15Hex Bolt	2
Ⓕ	Lon9 Side Tube	2	Ⓖ	10x 70 Hex Bolt	2
Ⓖ	M10x20 Flanged Hex Bolt	16	Ⓡ	3" Swivel Caster	2
Ⓕ	Foot Lever Plunger	2	Ⓢ	M12 Flange Nut	2
Ⓖ	Foot Lever Spring	2	Ⓣ	M10 Lock Washer	2
Ⓖ	M8 Flat Washer	8	Ⓤ	3" wheel	2
Ⓖ	M10 Flat Washer	2			

Safety Instructions for Mobile Bases

1. Be careful when moving to limit any finger pinch points.
2. Place base on a level surface and adjust levelers before placing the machine in position. This should keep the machine from rocking, while testing it for stability.
3. Test the stability in both the up (on the casters) and the down positions. Exercise caution when testing the stability of top heavy machines (drill presses, band saws, etc.).
4. Unplug any power tool before moving or repositioning your tool.
5. Always test your set-up for stability and safety after repositioning.
6. Care should be taken when planning the orientation of the machine onto the Universal Mobile Base. Transfer the weight off of the levelers to the casters will result in the machine tilting 1/2" toward the fixed wheels. When positioning top heavy tools such as a drill press or band saw, take advantage of the center of gravity, and position so that it will remain stable while on casters.
7. Never use your machine without engaging the floor locks and foot locks. Always lower the machine onto the non-skid levelers before operating.
8. When moving, always push the base, not the machine.

Assembly Examples

Be sure to follow safety and assembly instructions. Keep in mind the actual operation of your machine and the effect it has on overall stability.

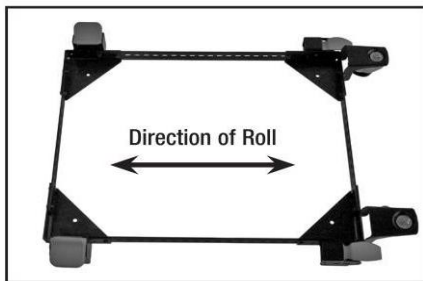

A long narrow base, such as on a jointer, would benefit from this arrangement. Most machines may be arranged to the convenience of the user.

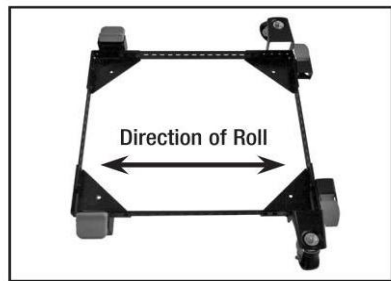

A short narrow base, such as found on a drill press or bandsaw may benefit from this arrangement. Due to swivel rotation, base may sit out of level. Rotate swivel wheel away from base to correct.

Safety Instructions for Mobile Bases

1. Be careful when moving to limit any finger pinch points.
2. Place base on a level surface and adjust levelers before placing the machine in position. This should keep the machine from rocking, while testing it for stability.
3. Test the stability in both the up (on the casters) and the down positions. Exercise caution when testing the stability of top heavy machines (drill presses, band saws, etc.).
4. Unplug any power tool before moving or repositioning your tool.
5. Always test your set-up for stability and safety after repositioning.
6. Care should be taken when planning the orientation of the machine onto the Universal Mobile Base. Transfer the weight off of the levelers to the casters will result in the machine tilting 1/2" toward the fixed wheels. When positioning top heavy tools such as a drill press or band saw, take advantage of the center of gravity, and position so that it will remain stable while on casters.
7. Never use your machine without engaging the floor locks and foot locks. Always lower the machine onto the non-skid levelers before operating.
8. When moving, always push the base, not the machine.

Assembly Examples

Be sure to follow safety and assembly instructions. Keep in mind the actual operation of your machine and the effect it has on overall stability.

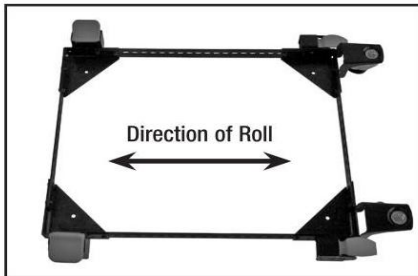

A long narrow base, such as on a jointer, would benefit from this arrangement. Most machines may be arranged to the convenience of the user.

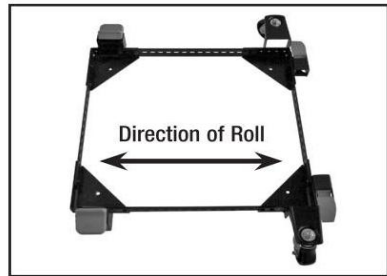

A short narrow base, such as found on a drill press or bandsaw may benefit from this arrangement. Due to swivel rotation, base may sit out of level. Rotate swivel wheel away from base to correct.

Assembly Instructions

What's in the box:

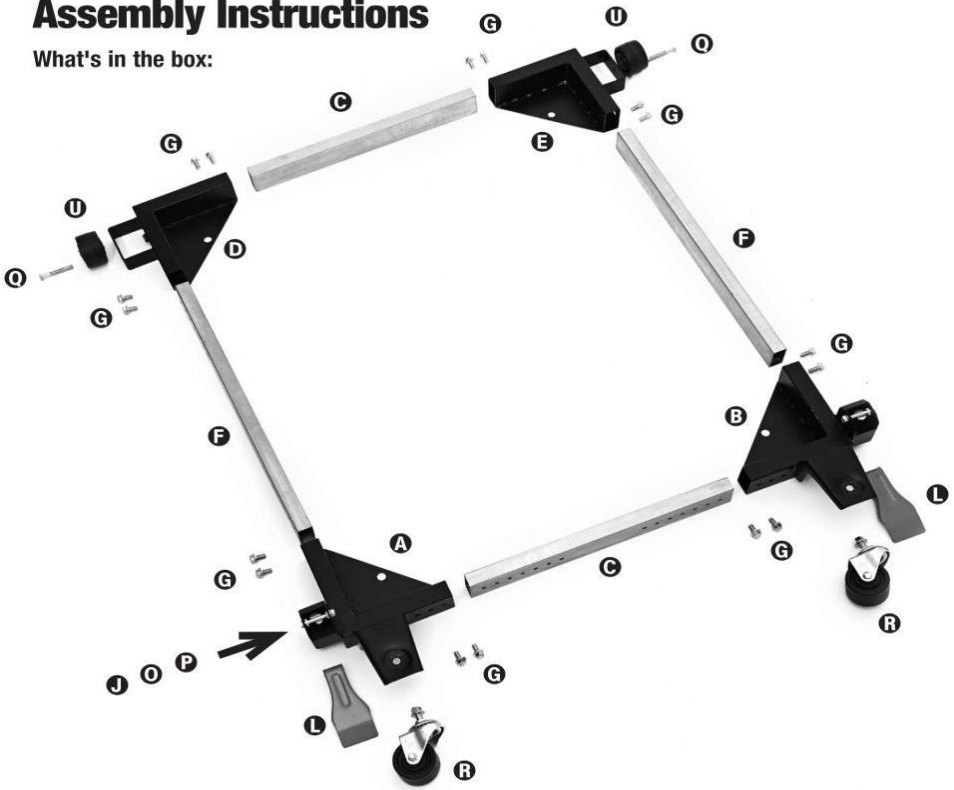

Step 1. Assemble front corners

1. Bolt foot lever **L** to base using part **J**, **O**, & **P**
2. Bolt swivel caster to base using part **S**

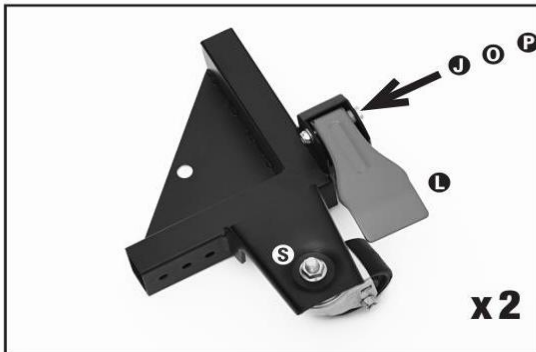

Step 2. Assemble back corners

1. Bolt wheel **U** to base using parts **K**, **T**, & **Q**

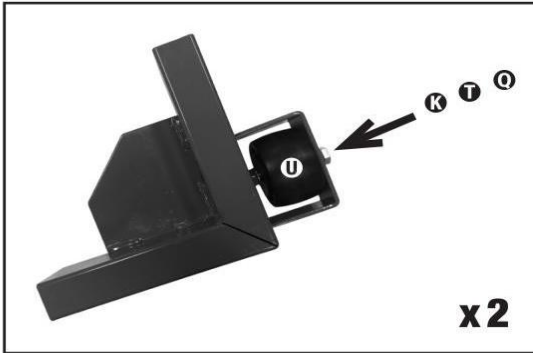

Step 3. Assemble side tubes

1. Bolt side tube between the front and back right corners using 4x part **G**
2. Bolt the tube out of the side of the front and back corner using 2x part **G** each



Step 4. Slide the machine onto the base

1. Slide your machine onto the mobile base before connecting the remaining corners

Step 5. Connect the remaining corners

1. Bolt side tube between the front and back right corners using 4x part **G**



2. Slide the left assembly onto the front and back rail – bolt it together using 4x part **G**

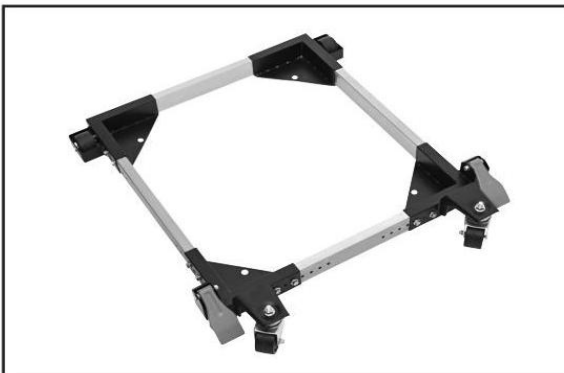

MAINTENANCE

1. Avoid prolonged exposure to the sun to avoid aging.
2. Inspect accessories for wear, cracks, and other damage before use, and replace defective accessories immediately.

Manufacturer: Shanghai muxin muyeyouxiangongsi

Address: Shuangchenglu 803nong11hao1602A-1609shi, baoshanqu, shanghai 200000 CN.

Imported to AUS: SIHAO PTY LTD, 1 ROKEVA STREET EASTWOOD NSW 2122 Australia

Imported to USA: Sanven Technology Ltd., Suite 250, 9166 Anaheim Place, Rancho Cucamonga, CA 91730

EC	REP
-----------	------------

E-CrossStu GmbH
Mainzer Landstr.69, 60329 Frankfurt am Main.

UK	REP
-----------	------------

YH CONSULTING LIMITED.
C/O YH Consulting Limited Office 147, Centurion House,
London Road, Staines-upon-Thames, Surrey, TW18 4AX

VEVOR[®]
TOUGH TOOLS, HALF PRICE

Technical Support and E-Warranty Certificate
www.vevor.com/support

VEVOR[®]

TOUGH TOOLS, HALF PRICE

Assistance technique et certificat de garantie

électronique www.vevor.com/support

BASE MOBILE

MODÈLE : GZB88094

Nous continuons à nous engager à vous fournir des outils à des prix compétitifs.

"Économisez la moitié", "Moitié prix" ou toute autre expression similaire que nous utilisons ne représente qu'une estimation des économies dont vous pourriez bénéficier en achetant certains outils chez nous par rapport aux grandes marques et ne signifie pas nécessairement couvrir toutes les catégories d'outils proposés, par nous.

Nous vous rappelons de bien vouloir vérifier attentivement lorsque vous passez une commande chez nous si vous économisez réellement la moitié par rapport aux grandes marques.

VEVOR[®]
TOUGH TOOLS, HALF PRICE

BASE MOBILE

MODÈLE : GZB88094



Photo pour référence

BESOIN D'AIDE ? CONTACTEZ-NOUS!

Vous avez des questions sur les produits ? Besoin d'une assistance technique ? N'hésitez pas à nous

contacter : Support technique et certificat de garantie électronique
www.vevor.com/support

Il s'agit des instructions originales, veuillez lire attentivement toutes les instructions du manuel avant de l'utiliser. VEVOR se réserve une interprétation claire de notre manuel d'utilisation. L'apparence du produit dépend du produit que vous avez reçu. Veuillez nous pardonner que nous ne vous informerons plus s'il y a des mises à jour technologiques ou logicielles sur notre produit.

CONSIGNES DE SÉCURITÉ



AVERTISSEMENT : Lisez et comprenez ce manuel avant

l'assemblage, l'installation, l'utilisation ou l'entretien de ce produit.

Le non-respect de ces avertissements et instructions peut entraîner décès, blessures corporelles ou dommages à des biens de valeur.

1. Veuillez ne pas le placer à proximité de matériaux inflammables.
2. Il est interdit de transporter des personnes sous quelque condition que ce soit.
3. Ce produit ne peut pas être utilisé pour monter ou descendre les escaliers.
4. La surcharge est strictement interdite.
5. Ne vous déplacez pas trop vite lorsque vous passez des zones de nids-de-poule.

CONSERVEZ CES INSTRUCTIONS

MODÈLE ET PARAMÈTRES

Matériel: Q235

Taille du produit : minimum 18 x 24 pouces, maximum 26,5 x 31,5 pouces

Capacité de charge : 1 500 lb maximum.

Remarque : Lors du réglage de la base mobile à la taille d'installation maximale, il ne peut pas être utilisé avec la capacité de charge maximale.

Liste des pièces :

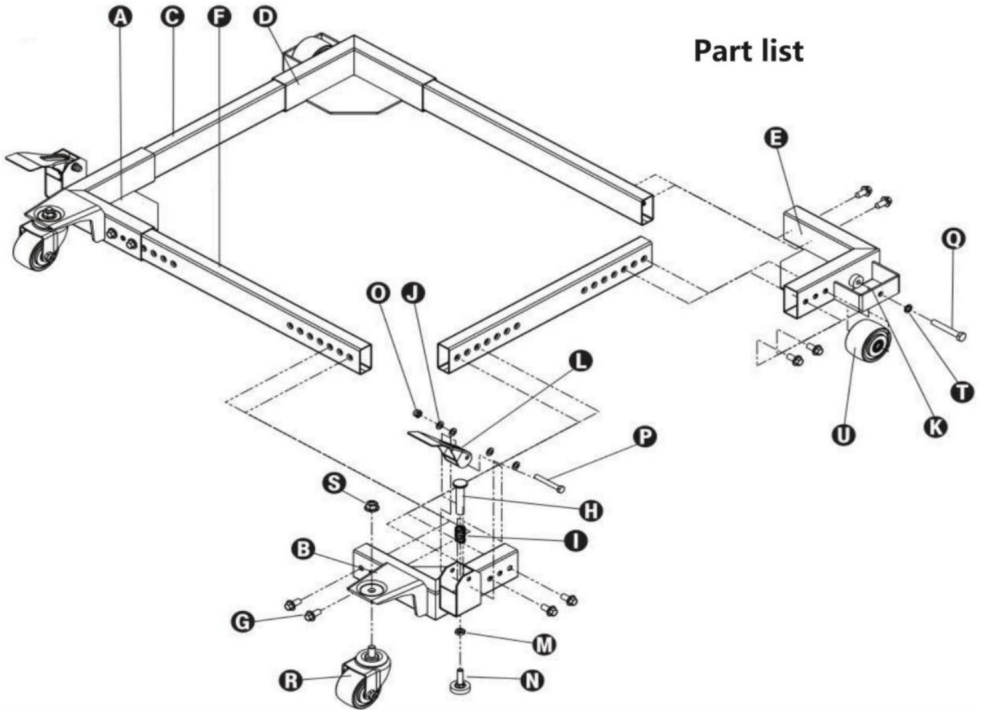

Part list

Liste des pièces

S/N	Description	Qté	S/N	Description	Qté
	Coin avant gauche			Levier à pied	2
	Coin avant droit	1	Contre-écrou M10		2
	Tube latéral court	2	Pied coulissant en caoutchouc		2
	Coin arrière gauche	1	Écrou Nyloc M8 1	Boulon	2
	Coin arrière droit		hexagonal 8x60-15		2
	Tube latéral Lon9		Boulon hexagonal 2	10x 70	2
	Boulon hexagonal à bride		Roulette pivotante 16	3"	2
M10x20	Plongeur à levier à pied	2	Écrou à bride M12 2		2
	Ressort de levier de pied		Rondelle de blocage M10		2
	Rondelle plate M8	8		Roue 3"	2
	Rondelle plate M10	2			

Safety Instructions for Mobile Bases

1. Be careful when moving to limit any finger pinch points.
2. Place base on a level surface and adjust levelers before placing the machine in position. This should keep the machine from rocking, while testing it for stability.
3. Test the stability in both the up (on the casters) and the down positions. Exercise caution when testing the stability of top heavy machines (drill presses, band saws, etc.).
4. Unplug any power tool before moving or repositioning your tool.
5. Always test your set-up for stability and safety after repositioning.
6. Care should be taken when planning the orientation of the machine onto the Universal Mobile Base. Transfer the weight off of the levelers to the casters will result in the machine tilting 1/2" toward the fixed wheels. When positioning top heavy tools such as a drill press or band saw, take advantage of the center of gravity, and position so that it will remain stable while on casters.
7. Never use your machine without engaging the floor locks and foot locks. Always lower the machine onto the non-skid levelers before operating.
8. When moving, always push the base, not the machine.

Assembly Examples

Be sure to follow safety and assembly instructions. Keep in mind the actual operation of your machine and the effect it has on overall stability.

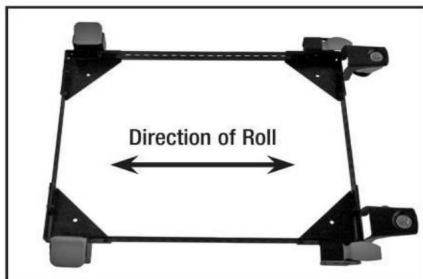

A long narrow base, such as on a jointer, would benefit from this arrangement. Most machines may be arranged to the convenience of the user.

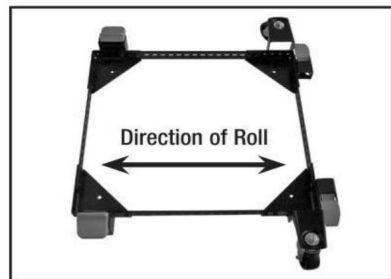

A short narrow base, such as found on a drill press or bandsaw may benefit from this arrangement. Due to swivel rotation, base may sit out of level. Rotate swivel wheel away from base to correct.

Safety Instructions for Mobile Bases

1. Be careful when moving to limit any finger pinch points.
2. Place base on a level surface and adjust levelers before placing the machine in position. This should keep the machine from rocking, while testing it for stability.
3. Test the stability in both the up (on the casters) and the down positions. Exercise caution when testing the stability of top heavy machines (drill presses, band saws, etc.).
4. Unplug any power tool before moving or repositioning your tool.
5. Always test your set-up for stability and safety after repositioning.
6. Care should be taken when planning the orientation of the machine onto the Universal Mobile Base. Transfer the weight off of the levelers to the casters will result in the machine tilting 1/2" toward the fixed wheels. When positioning top heavy tools such as a drill press or band saw, take advantage of the center of gravity, and position so that it will remain stable while on casters.
7. Never use your machine without engaging the floor locks and foot locks. Always lower the machine onto the non-skid levelers before operating.
8. When moving, always push the base, not the machine.

Assembly Examples

Be sure to follow safety and assembly instructions. Keep in mind the actual operation of your machine and the effect it has on overall stability.

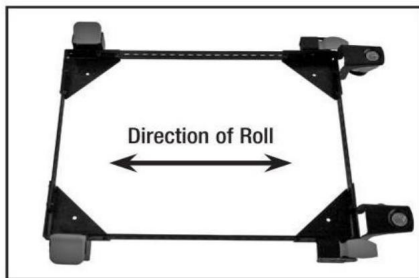

A long narrow base, such as on a jointer, would benefit from this arrangement. Most machines may be arranged to the convenience of the user.

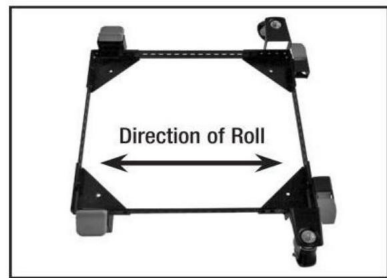

A short narrow base, such as found on a drill press or bandsaw may benefit from this arrangement. Due to swivel rotation, base may sit out of level. Rotate swivel wheel away from base to correct.

Assembly Instructions

What's in the box:

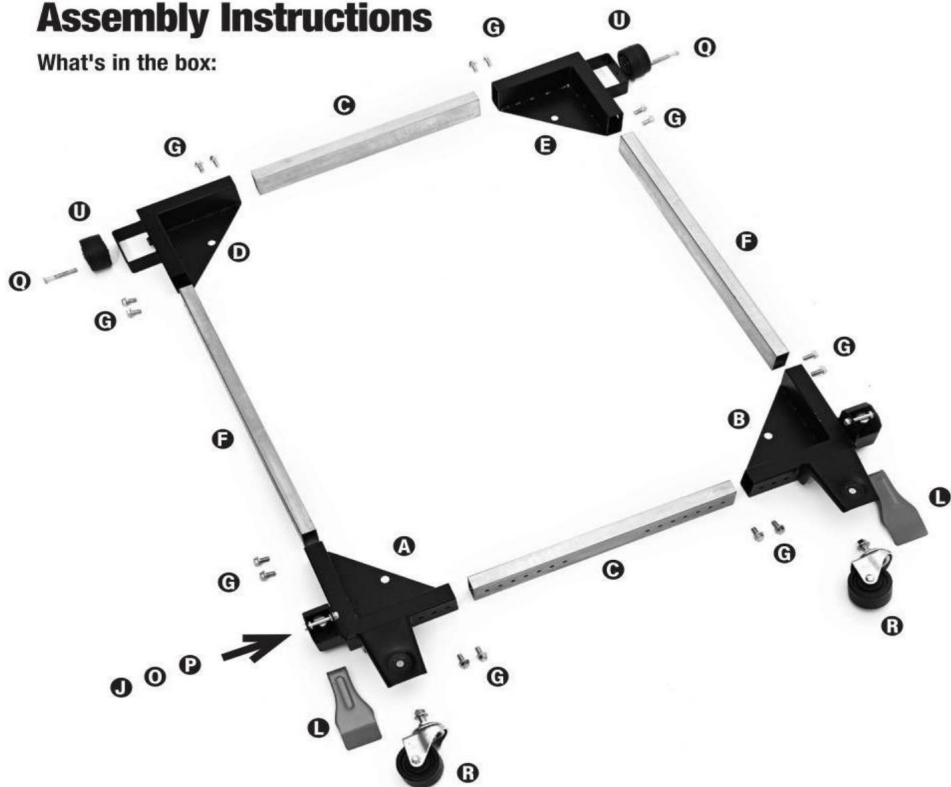

Step 1. Assemble front corners

1. Bolt foot lever **L** to base using part **J**, **O**, & **P**
2. Bolt swivel caster to base using part **S**



Step 2. Assemble back corners

1. Bolt wheel **U** to base using parts **K**, **T**, & **Q**

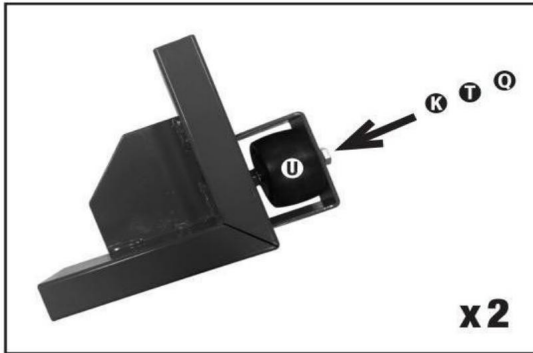

Step 3. Assemble side tubes

1. Bolt side tube between the front and back right corners using 4x part **G**
2. Bolt the tube out of the side of the front and back corner using 2x part **G** each



Step 4. Slide the machine onto the base

1. Slide your machine onto the mobile base before connecting the remaining corners

Step 5. Connect the remaining corners

1. Bolt side tube between the front and back right corners using 4x part **G**



2. Slide the left assembly onto the front and back rail – bolt it together using 4x part **G**



ENTRETIEN

1. Évitez l'exposition prolongée au soleil pour éviter le vieillissement.
2. Inspectez les accessoires pour déceler l'usure, les fissures et autres dommages avant utilisation, et remplacez immédiatement les accessoires défectueux.

Fabricant : Shanghaimuxinmuyeyouxiangongsi

Adresse : Shuangchenglu 803nong11hao1602A-1609shi, baoshanqu, Shanghai
200000 CN.

Importé en Australie : SIHAO PTY LTD, 1 ROKEVA STREETESTWOOD NSW
2122 Australie

Importé aux États-Unis : Sanven Technology Ltd., Suite 250, 9166 Anaheim Place, Rancho
Cucamonga, CA 91730

REPRÉSENTANT CE	
-----------------	--

E-CrossStu GmbH
Mainzer Landstr.69, 60329 Francfort-sur-le-Main.

REPRÉSENTANT DU ROYAUME-UNI	
-----------------------------	--

YH CONSULTING LIMITÉE.
C/O YH Consulting Limited Bureau 147, Centurion House,
London Road, Staines-upon-Thames, Surrey, TW18 4AX

VEVOR®
TOUGH TOOLS, HALF PRICE

Assistance technique et certificat de garantie
électronique www.vevor.com/support

VEVOR[®]

TOUGH TOOLS, HALF PRICE

Technischer Support und E-Garantie-Zertifikat

www.vevor.com/support

MOBILE BASIS

MODELL: GZB88094

Wir sind weiterhin bestrebt, Ihnen Werkzeuge zu wettbewerbsfähigen Preisen anzubieten.

„Sparen Sie die Hälfte“, „Halber Preis“ oder andere ähnliche Ausdrücke, die wir verwenden, stellen nur eine Schätzung der Ersparnis dar, die Sie beim Kauf bestimmter Werkzeuge bei uns im Vergleich zu den großen Topmarken erzielen können, und decken nicht unbedingt alle von uns angebotenen Werkzeugkategorien ab. Wir möchten Sie freundlich daran erinnern, bei Ihrer Bestellung bei uns sorgfältig zu prüfen, ob Sie im Vergleich zu den großen Topmarken tatsächlich die Hälfte sparen.

VEVOR[®]

TOUGH TOOLS, HALF PRICE

MOBILE BASIS

MODELL: GZB88094



Foto als Referenz

Brauchen Sie Hilfe? Kontaktieren Sie uns!

Haben Sie Fragen zum Produkt? Benötigen Sie technischen Support? Bitte kontaktieren Sie uns:

Technischer Support und E-Garantie-Zertifikat www.vevor.com/support

Dies ist die Originalanleitung. Bitte lesen Sie alle Anweisungen sorgfältig durch, bevor Sie das Gerät in Betrieb nehmen. VEVOR behält sich eine klare Auslegung unserer Bedienungsanleitung vor. Das Erscheinungsbild des Produkts richtet sich nach dem Produkt, das Sie erhalten haben. Bitte verzeihen Sie uns, dass wir Sie nicht erneut informieren, wenn es Technologie- oder Software-Updates für unser Produkt gibt.

SICHERHEITSHINWEISE



WARNUNG: Lesen und verstehen Sie dieses Handbuch, bevor Sie Montage, Installation, Bedienung oder Wartung dieses Produkts. Die Nichtbeachtung dieser Warnungen und Anweisungen kann zu

Tod, Personenschäden oder Schäden an wertvollem Eigentum.

1. Bitte nicht in der Nähe von brennbaren Materialien platzieren.
2. Die Beförderung von Personen ist unter allen Umständen verboten.
3. Dieses Produkt kann nicht zum Treppensteigen verwendet werden.
4. Überlastung ist strengstens verboten.
5. Fahren Sie nicht zu schnell durch Schlaglöcher.

BEWAHREN SIE DIESE ANWEISUNGEN AUF

MODELL UND PARAMETER

Werkstoff: Q235

Produktgröße: Mindestens 18 x 24 Zoll, maximal 26,5 x 31,5 Zoll

Tragfähigkeit: max. 1500 lbs.

Hinweis: Beim Einstellen des Fahrgestells auf die maximale Einbaugröße kann nicht mit der maximalen Tragkraft genutzt werden.

Stückliste:

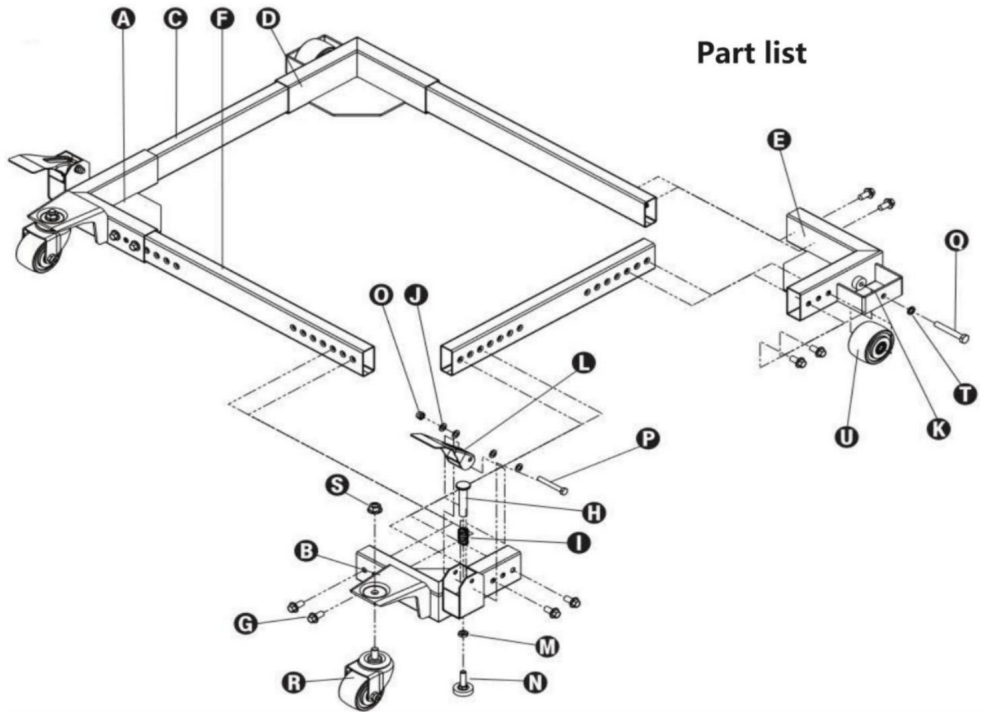

Ersatzteilliste

Zeilennummer	Beschreibung	Menge S/	Beschreibung	Menge		
ÿ	Vordere linke Ecke	N 1 ÿ	Fußhebel	2		
ÿ	Vordere rechte Ecke	1 ÿ	M10 Kontermutter	2		
ÿ	Kurzes Seitenrohr	2 ÿ	Gummi-Gleitfuß	2		
ÿ	Hintere linke Ecke	1 ÿ	M8 Nyloc-Mutter	1 ÿ	2	
ÿ	Hintere rechte Ecke	8x60-15	Sechskantschraube	2		
ÿ	Lon9 Seitenrohr	2 ÿ	10x 70 Sechskantschraube	2		
ÿ	M10x20 Sechskantschraube mit	16 ÿ	3" Lenkrolle	2		
Flansch ÿ	Fußhebelstößel	2 ÿ	M12 Flanschmutter	2 ÿ	M10	2
ÿ	Fußhebelfeder		Federscheibe	2		
ÿ	M8 flache Unterlegscheibe	8 ÿ		3" Rad	2	
ÿ	M10 flache Unterlegscheibe	2				

Safety Instructions for Mobile Bases

1. Be careful when moving to limit any finger pinch points.
2. Place base on a level surface and adjust levelers before placing the machine in position. This should keep the machine from rocking, while testing it for stability.
3. Test the stability in both the up (on the casters) and the down positions. Exercise caution when testing the stability of top heavy machines (drill presses, band saws, etc.).
4. Unplug any power tool before moving or repositioning your tool.
5. Always test your set-up for stability and safety after repositioning.
6. Care should be taken when planning the orientation of the machine onto the Universal Mobile Base. Transfer the weight off of the levelers to the casters will result in the machine tilting 1/2" toward the fixed wheels. When positioning top heavy tools such as a drill press or band saw, take advantage of the center of gravity, and position so that it will remain stable while on casters.
7. Never use your machine without engaging the floor locks and foot locks. Always lower the machine onto the non-skid levelers before operating.
8. When moving, always push the base, not the machine.

Assembly Examples

Be sure to follow safety and assembly instructions. Keep in mind the actual operation of your machine and the effect it has on overall stability.

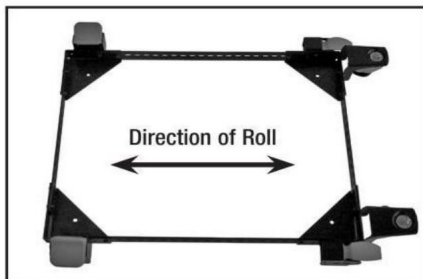

A long narrow base, such as on a jointer, would benefit from this arrangement. Most machines may be arranged to the convenience of the user.

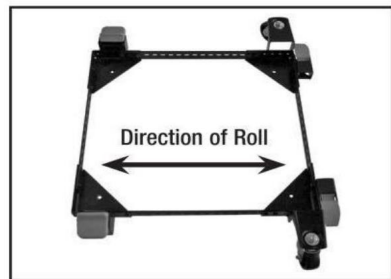

A short narrow base, such as found on a drill press or bandsaw may benefit from this arrangement. Due to swivel rotation, base may sit out of level. Rotate swivel wheel away from base to correct.

Safety Instructions for Mobile Bases

1. Be careful when moving to limit any finger pinch points.
2. Place base on a level surface and adjust levelers before placing the machine in position. This should keep the machine from rocking, while testing it for stability.
3. Test the stability in both the up (on the casters) and the down positions. Exercise caution when testing the stability of top heavy machines (drill presses, band saws, etc.).
4. Unplug any power tool before moving or repositioning your tool.
5. Always test your set-up for stability and safety after repositioning.
6. Care should be taken when planning the orientation of the machine onto the Universal Mobile Base. Transfer the weight off of the levelers to the casters will result in the machine tilting 1/2" toward the fixed wheels. When positioning top heavy tools such as a drill press or band saw, take advantage of the center of gravity, and position so that it will remain stable while on casters.
7. Never use your machine without engaging the floor locks and foot locks. Always lower the machine onto the non-skid levelers before operating.
8. When moving, always push the base, not the machine.

Assembly Examples

Be sure to follow safety and assembly instructions. Keep in mind the actual operation of your machine and the effect it has on overall stability.

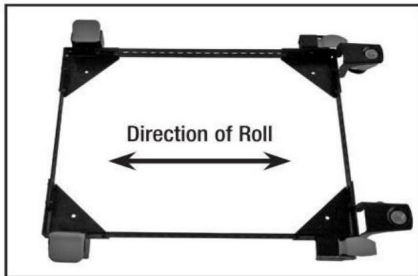

A long narrow base, such as on a jointer, would benefit from this arrangement. Most machines may be arranged to the convenience of the user.

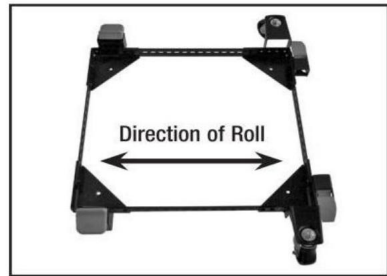

A short narrow base, such as found on a drill press or bandsaw may benefit from this arrangement. Due to swivel rotation, base may sit out of level. Rotate swivel wheel away from base to correct.

Assembly Instructions

What's in the box:

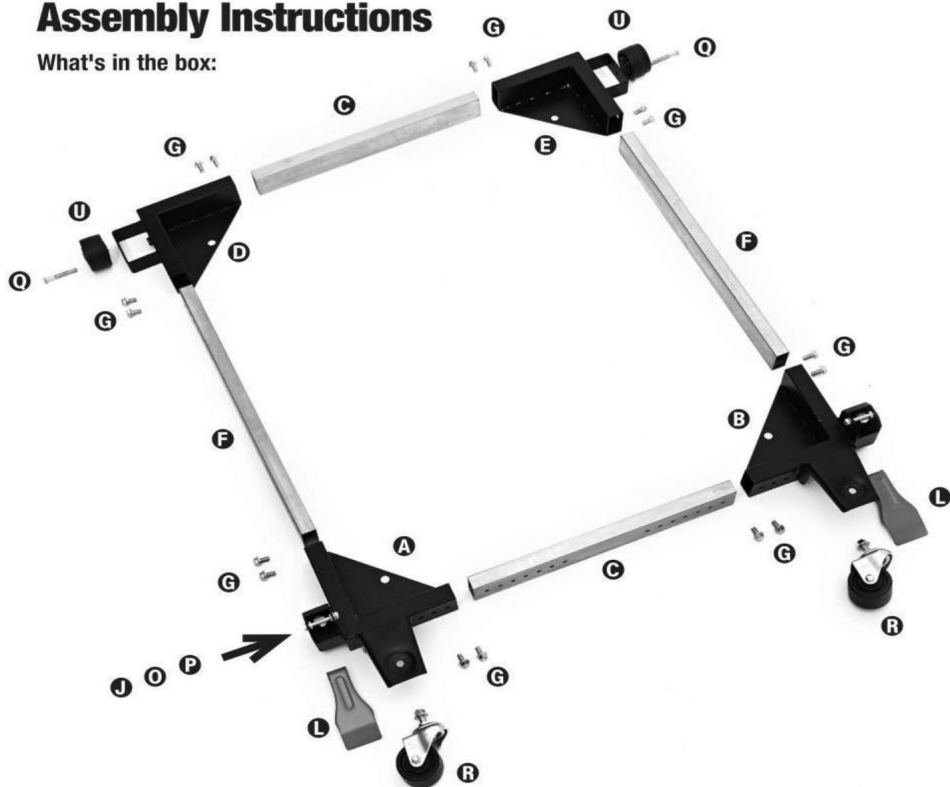

Step 1. Assemble front corners

1. Bolt foot lever **L** to base using part **J**, **O**, & **P**
2. Bolt swivel caster to base using part **S**



Step 2. Assemble back corners

1. Bolt wheel **U** to base using parts **K**, **T**, & **Q**

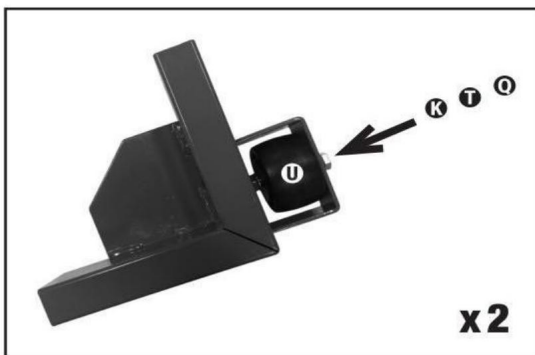

Step 3. Assemble side tubes

1. Bolt side tube between the front and back right corners using 4x part **G**
2. Bolt the tube out of the side of the front and back corner using 2x part **G** each



Step 4. Slide the machine onto the base

1. Slide your machine onto the mobile base before connecting the remaining corners

Step 5. Connect the remaining corners

1. Bolt side tube between the front and back right corners using 4x part **G**



2. Slide the left assembly onto the front and back rail – bolt it together using 4x part **G**



WARTUNG

1. Vermeiden Sie längere Sonneneinstrahlung, um der Hautalterung vorzubeugen.
2. Überprüfen Sie Zubehör vor dem Gebrauch auf Verschleiß, Risse und andere Schäden und Tauschen Sie defektes Zubehör umgehend aus.

Hersteller: Shanghaimuxinmuyeyouxiangongsi

Adresse: Shuangchenglu 803nong11hao1602A-1609shi, baoshanqu, Shanghai 200000 CN.

Nach AUS importiert: SIHAO PTY LTD, 1 ROKEVA STREETEASTWOOD NSW 2122 Australien

Importiert in die USA: Sanven Technology Ltd., Suite 250, 9166 Anaheim Place, Rancho Cucamonga, CA 91730

Vertreter der EG	
-------------------------	--

E-CrossStu GmbH

Mainzer Landstr.69, 60329 Frankfurt am Main.

UK REP	
---------------	--

YH CONSULTING LIMITED.

C/O YH Consulting Limited Office 147, Centurion House, London Road, Staines-upon-Thames, Surrey, TW18 4AX

VEVOR[®]
TOUGH TOOLS, HALF PRICE

Technischer Support und E-Garantie-Zertifikat
www.vevor.com/support

VEVOR[®]

TOUGH TOOLS, HALF PRICE

Supporto tecnico e certificato di garanzia
elettronica www.vevor.com/support

BASE MOBILE

MODELLO: GZB88094

Continuiamo a impegnarci per fornirvi strumenti a prezzi competitivi.
"Risparmia la metà", "Metà prezzo" o qualsiasi altra espressione simile da noi utilizzata rappresenta solo una stima del risparmio che potresti trarre dall'acquistare determinati strumenti con noi rispetto ai principali marchi più importanti e non significa necessariamente coprire tutte le categorie di strumenti offerti da noi. Ti ricordiamo di verificare attentamente quando effettui un ordine con noi se stai effettivamente risparmiando la metà rispetto ai migliori marchi principali.

VEVOR®

TOUGH TOOLS, HALF PRICE

BASE MOBILE

MODELLO: GZB88094



Foto per riferimento

HAI BISOGNO DI AIUTO? CONTATTACI!

Hai domande sul prodotto? Hai bisogno di supporto tecnico? Non esitate a contattarci:

Supporto

**tecnico e certificato di garanzia elettronica [www.vevor.com/
support](http://www.vevor.com/support)**

Queste sono le istruzioni originali, leggere attentamente tutte le istruzioni del manuale prima dell'uso. VEVOR si riserva una chiara interpretazione del nostro manuale d'uso. L'aspetto del prodotto sarà soggetto al prodotto ricevuto. Ti preghiamo di perdonarci se non ti informeremo più se sono presenti aggiornamenti tecnologici o software sul nostro prodotto.

ISTRUZIONI DI SICUREZZA



ATTENZIONE: Leggere e comprendere questo manuale prima

durante l'assemblaggio, l'installazione, il funzionamento o la manutenzione di questo prodotto.

La mancata osservanza di queste avvertenze e istruzioni può causare morte, lesioni personali o danni a beni di valore.

1. Si prega di non posizionarlo vicino a materiali infiammabili.
2. È vietato trasportare persone in qualsiasi condizione.
3. Questo prodotto non può essere utilizzato per salire o scendere le scale.
4. Il sovraccarico è severamente vietato.
5. Non muoverti troppo velocemente quando attraversi aree con buche.

CONSERVA QUESTE ISTRUZIONI

MODELLO E PARAMETRI

Materiale: Q235

Dimensioni del prodotto: minimo 18x24 pollici, massimo 26,5x31,5 pollici

Capacità di carico: 1500 libbre max.

Nota: quando si regola la base mobile alla dimensione massima di installazione, essa non può essere utilizzato con la capacità di carico massima.

Elenco delle parti:

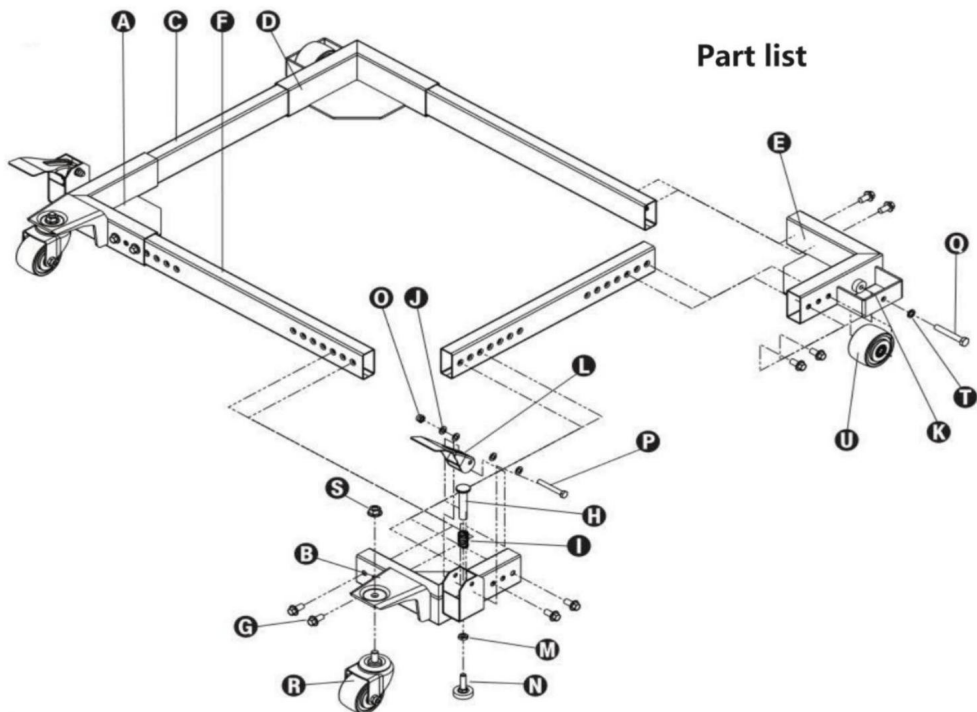

Part list

Elenco delle parti

S/N	Descrizione	Qtà	S/N 1	Descrizione	Qtà
ÿ	Angolo anteriore sinistro	ÿ		Leva a pedale	2
ÿ	Angolo anteriore destro		Dado di bloccaggio 1 ÿ M10		2
ÿ	Tubo dal lato corto	2 ÿ	Piedino scorrevole in gomma		2
ÿ	Angolo posteriore sinistro	1 ÿ	Dado Nyloc M8 1 ÿ Bullone esagonale 8x60-15		2
ÿ	Angolo posteriore destro		Bullone esagonale 10x 70		2
ÿ	Tubo laterale Lon9	2 ÿ	Bullone esagonale 10x 70		2
ÿ	Bullone esagonale flangiato	16	Ruote girevoli ÿ 3".		2
M10x20 ÿ	Stantuffo con leva a pedale	2 ÿ	Dado flangiato M12 2 ÿ		2
ÿ	Molla della leva a pedale		Rondella di sicurezza M10		2
ÿ	Rondella piatta M8	8 ÿ		Ruota da 3".	2
ÿ	Rondella piatta M10	2			

Safety Instructions for Mobile Bases

1. Be careful when moving to limit any finger pinch points.
2. Place base on a level surface and adjust levelers before placing the machine in position. This should keep the machine from rocking, while testing it for stability.
3. Test the stability in both the up (on the casters) and the down positions. Exercise caution when testing the stability of top heavy machines (drill presses, band saws, etc.).
4. Unplug any power tool before moving or repositioning your tool.
5. Always test your set-up for stability and safety after repositioning.
6. Care should be taken when planning the orientation of the machine onto the Universal Mobile Base. Transfer the weight off of the levelers to the casters will result in the machine tilting 1/2" toward the fixed wheels. When positioning top heavy tools such as a drill press or band saw, take advantage of the center of gravity, and position so that it will remain stable while on casters.
7. Never use your machine without engaging the floor locks and foot locks. Always lower the machine onto the non-skid levelers before operating.
8. When moving, always push the base, not the machine.

Assembly Examples

Be sure to follow safety and assembly instructions. Keep in mind the actual operation of your machine and the effect it has on overall stability.

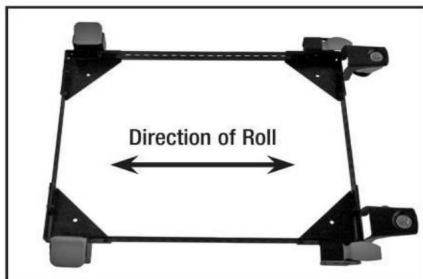

A long narrow base, such as on a jointer, would benefit from this arrangement. Most machines may be arranged to the convenience of the user.

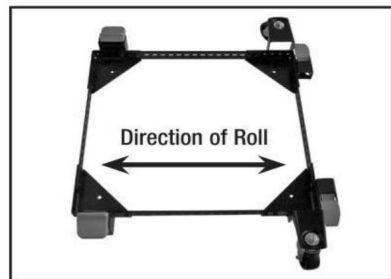

A short narrow base, such as found on a drill press or bandsaw may benefit from this arrangement. Due to swivel rotation, base may sit out of level. Rotate swivel wheel away from base to correct.

Safety Instructions for Mobile Bases

1. Be careful when moving to limit any finger pinch points.
2. Place base on a level surface and adjust levelers before placing the machine in position. This should keep the machine from rocking, while testing it for stability.
3. Test the stability in both the up (on the casters) and the down positions. Exercise caution when testing the stability of top heavy machines (drill presses, band saws, etc.).
4. Unplug any power tool before moving or repositioning your tool.
5. Always test your set-up for stability and safety after repositioning.
6. Care should be taken when planning the orientation of the machine onto the Universal Mobile Base. Transfer the weight off of the levelers to the casters will result in the machine tilting 1/2" toward the fixed wheels. When positioning top heavy tools such as a drill press or band saw, take advantage of the center of gravity, and position so that it will remain stable while on casters.
7. Never use your machine without engaging the floor locks and foot locks. Always lower the machine onto the non-skid levelers before operating.
8. When moving, always push the base, not the machine.

Assembly Examples

Be sure to follow safety and assembly instructions. Keep in mind the actual operation of your machine and the effect it has on overall stability.

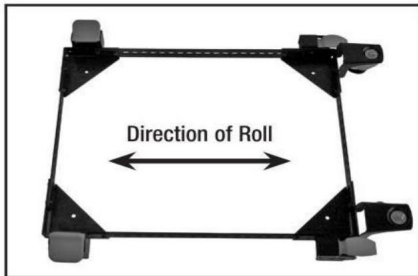

A long narrow base, such as on a jointer, would benefit from this arrangement. Most machines may be arranged to the convenience of the user.

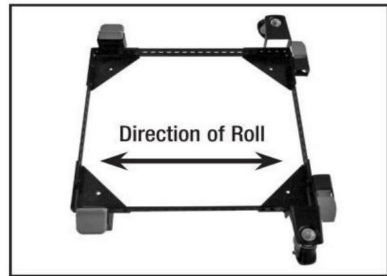

A short narrow base, such as found on a drill press or bandsaw may benefit from this arrangement. Due to swivel rotation, base may sit out of level. Rotate swivel wheel away from base to correct.

Assembly Instructions

What's in the box:

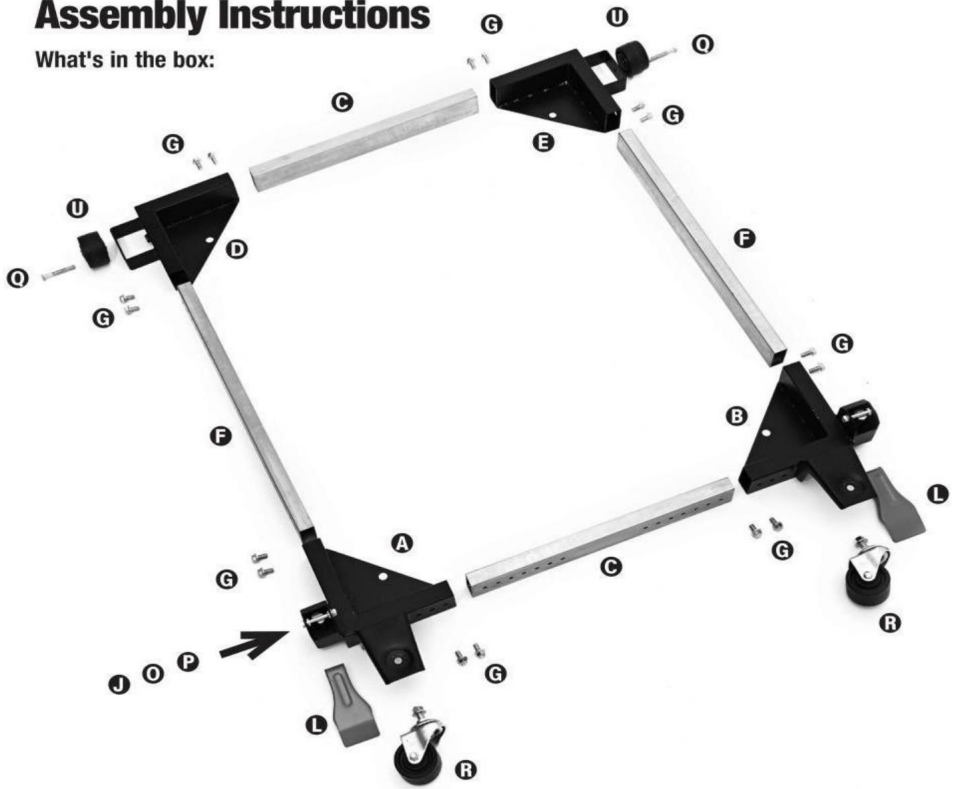

Step 1. Assemble front corners

1. Bolt foot lever **L** to base using part **J**, **O**, & **P**
2. Bolt swivel caster to base using part **S**

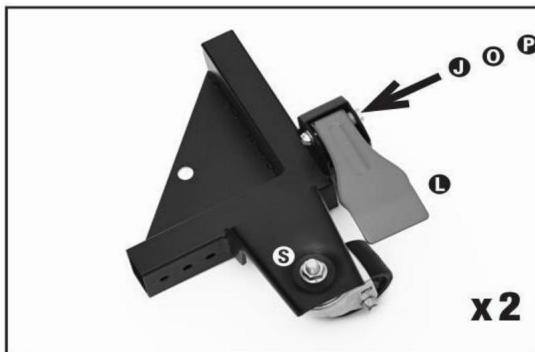

Step 2. Assemble back corners

1. Bolt wheel **U** to base using parts **K**, **T**, & **Q**

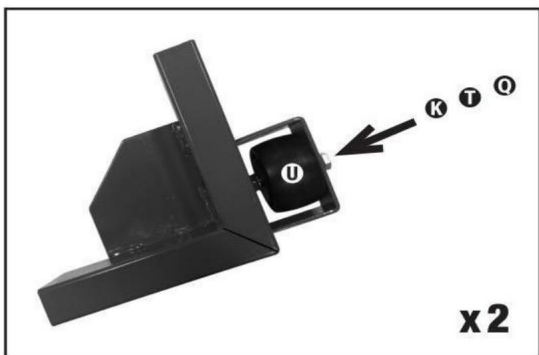

Step 3. Assemble side tubes

1. Bolt side tube between the front and back right corners using 4x part **G**
2. Bolt the tube out of the side of the front and back corner using 2x part **G** each



Step 4. Slide the machine onto the base

1. Slide your machine onto the mobile base before connecting the remaining corners

Step 5. Connect the remaining corners

1. Bolt side tube between the front and back right corners using 4x part **G**



2. Slide the left assembly onto the front and back rail – bolt it together using 4x part **G**



MANUTENZIONE

1. Evitare l'esposizione prolungata al sole per evitare l'invecchiamento.
2. Ispezionare gli accessori per eventuali segni di usura, crepe e altri danni prima dell'uso e sostituire immediatamente gli accessori difettosi.

Produttore: Shanghaimuxinmuyeyouxiangongsi

Indirizzo: Shuangchenglu 803nong11hao1602A-1609shi, baoshanqu, shanghai 200000 CN.

Importato in AUS: SIHAO PTY LTD, 1 ROKEVA STREETEASTWOOD NSW 2122Australia

Importato negli Stati Uniti: Sanven Technology Ltd., Suite 250, 9166 Anaheim Place, Rancho Cucamonga, CA 91730



E-CrossStu GmbH
Mainzer Landstr.69, 60329 Francoforte sul Meno.



YH CONSULENZA LIMITATA.
C/O YH Consulting Limited Ufficio 147, Centurion House,
London Road, Staines-upon-Thames, Surrey, TW18 4AX

VEVOR®
TOUGH TOOLS, HALF PRICE

Supporto tecnico e certificato di garanzia
elettronica www.vevor.com/support

VEVOR[®]

TOUGH TOOLS, HALF PRICE

Soporte técnico y certificado de garantía
electrónica www.vevor.com/support

BASE MÓVIL

MODELO: GZB88094

Seguimos comprometidos a proporcionarle herramientas a precios competitivos.
"Ahorre a mitad de precio", "A mitad de precio" o cualquier otra expresión similar utilizada por nosotros solo representa una estimación de los ahorros que podría beneficiarse al comprar ciertas herramientas con nosotros en comparación con las principales marcas y no significa necesariamente cubrir todas las categorías de herramientas ofrecidas por nosotros. Le recordamos que, cuando realice un pedido con nosotros, verifique cuidadosamente si realmente está ahorrando la mitad en comparación con las principales marcas.

VEVOR[®]
TOUGH TOOLS, HALF PRICE

BASE MÓVIL

MODELO: GZB88094



Foto como referencia

¿NECESITAR AYUDA? ¡CONTÁCTANOS!

¿Tiene preguntas sobre el producto? ¿Necesita soporte técnico? No dude en contactarnos:
Soporte

técnico y certificado de garantía electrónica www.vevor.com/support

Estas son las instrucciones originales; lea atentamente todas las instrucciones del manual antes de operar. VEVOR se reserva una interpretación clara de nuestro manual de usuario. La apariencia del producto estará sujeta al producto que recibió. Perdone que no le informaremos nuevamente si hay actualizaciones de tecnología o software en nuestro producto.

INSTRUCCIONES DE SEGURIDAD



ADVERTENCIA: Lea y comprenda este manual antes
ensamblar, instalar, operar o dar servicio a este producto.

El incumplimiento de estas advertencias e instrucciones puede causar
muerte, lesiones personales o daños a bienes valiosos.

1. No lo coloques cerca de materiales inflamables.
2. Está prohibido transportar personas bajo cualquier condición.
3. Este producto no se puede utilizar para subir o bajar escaleras.
4. La sobrecarga está estrictamente prohibida.
5. No se mueva demasiado rápido al pasar por zonas con baches.

GUARDE ESTAS INSTRUCCIONES

MODELO Y PARÁMETROS

Materiales: Q235

Tamaño del producto: Mínimo 18x24 pulgadas, máximo 26,5x31,5 pulgadas

Capacidad de carga: 1500 libras máx.

Nota: Al ajustar la base móvil al tamaño máximo de instalación,
no se puede utilizar con la capacidad de carga máxima.

Lista de piezas:

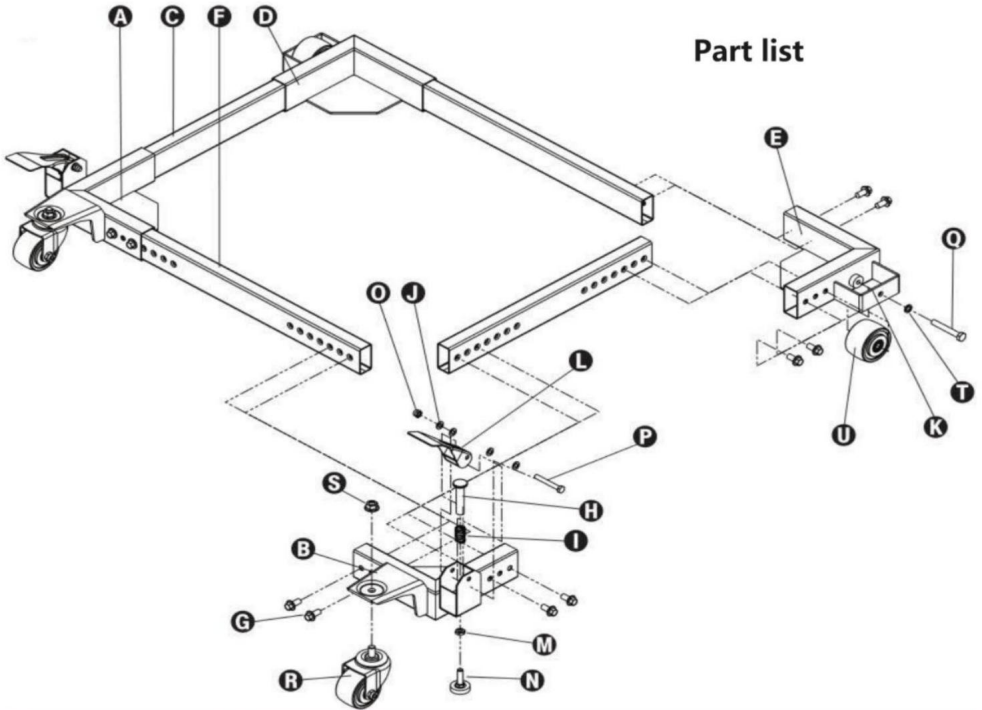

Part list

Lista de piezas

S/N	Descripción	Cant.	S/N	Descripción	Cantidad
	Esquina delantera izquierda	1		Palanca de pie	2
	Esquina delantera derecha	1	Contratuerca M10		2
	Tubo lateral corto	2	Pie deslizante de goma		2
	Esquina trasera izquierda	1	Tuerca Nyloc M8 1	Perno	2
	Esquina trasera derecha	hexagonal 8x60-15			2
	Tubo lateral Lon9	2	Perno hexagonal 10x 70		2
	Perno hexagonal con brida M10x20		Rueda giratoria de 16 3"		2
	Émbolo de palanca de pie	2	Tuerca con brida M12 2		2
	Resorte de palanca de pie		Arandela de seguridad M10		2
	Arandela plana M8	8		rueda de 3"	2
	Arandela plana M10	2			

Safety Instructions for Mobile Bases

1. Be careful when moving to limit any finger pinch points.
2. Place base on a level surface and adjust levelers before placing the machine in position. This should keep the machine from rocking, while testing it for stability.
3. Test the stability in both the up (on the casters) and the down positions. Exercise caution when testing the stability of top heavy machines (drill presses, band saws, etc.).
4. Unplug any power tool before moving or repositioning your tool.
5. Always test your set-up for stability and safety after repositioning.
6. Care should be taken when planning the orientation of the machine onto the Universal Mobile Base. Transfer the weight off of the levelers to the casters will result in the machine tilting 1/2" toward the fixed wheels. When positioning top heavy tools such as a drill press or band saw, take advantage of the center of gravity, and position so that it will remain stable while on casters.
7. Never use your machine without engaging the floor locks and foot locks. Always lower the machine onto the non-skid levelers before operating.
8. When moving, always push the base, not the machine.

Assembly Examples

Be sure to follow safety and assembly instructions. Keep in mind the actual operation of your machine and the effect it has on overall stability.

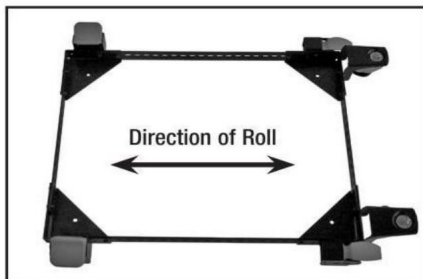

A long narrow base, such as on a jointer, would benefit from this arrangement. Most machines may be arranged to the convenience of the user.

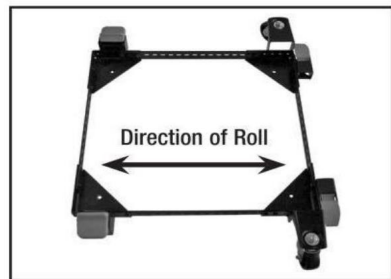

A short narrow base, such as found on a drill press or bandsaw may benefit from this arrangement. Due to swivel rotation, base may sit out of level. Rotate swivel wheel away from base to correct.

Safety Instructions for Mobile Bases

1. Be careful when moving to limit any finger pinch points.
2. Place base on a level surface and adjust levelers before placing the machine in position. This should keep the machine from rocking, while testing it for stability.
3. Test the stability in both the up (on the casters) and the down positions. Exercise caution when testing the stability of top heavy machines (drill presses, band saws, etc.).
4. Unplug any power tool before moving or repositioning your tool.
5. Always test your set-up for stability and safety after repositioning.
6. Care should be taken when planning the orientation of the machine onto the Universal Mobile Base. Transfer the weight off of the levelers to the casters will result in the machine tilting 1/2" toward the fixed wheels. When positioning top heavy tools such as a drill press or band saw, take advantage of the center of gravity, and position so that it will remain stable while on casters.
7. Never use your machine without engaging the floor locks and foot locks. Always lower the machine onto the non-skid levelers before operating.
8. When moving, always push the base, not the machine.

Assembly Examples

Be sure to follow safety and assembly instructions. Keep in mind the actual operation of your machine and the effect it has on overall stability.

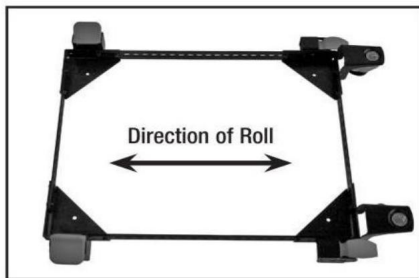

A long narrow base, such as on a jointer, would benefit from this arrangement. Most machines may be arranged to the convenience of the user.

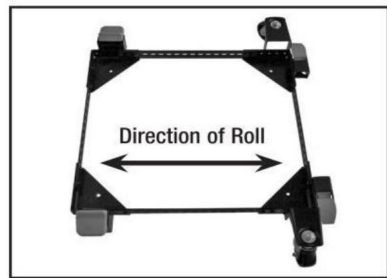

A short narrow base, such as found on a drill press or bandsaw may benefit from this arrangement. Due to swivel rotation, base may sit out of level. Rotate swivel wheel away from base to correct.

Assembly Instructions

What's in the box:

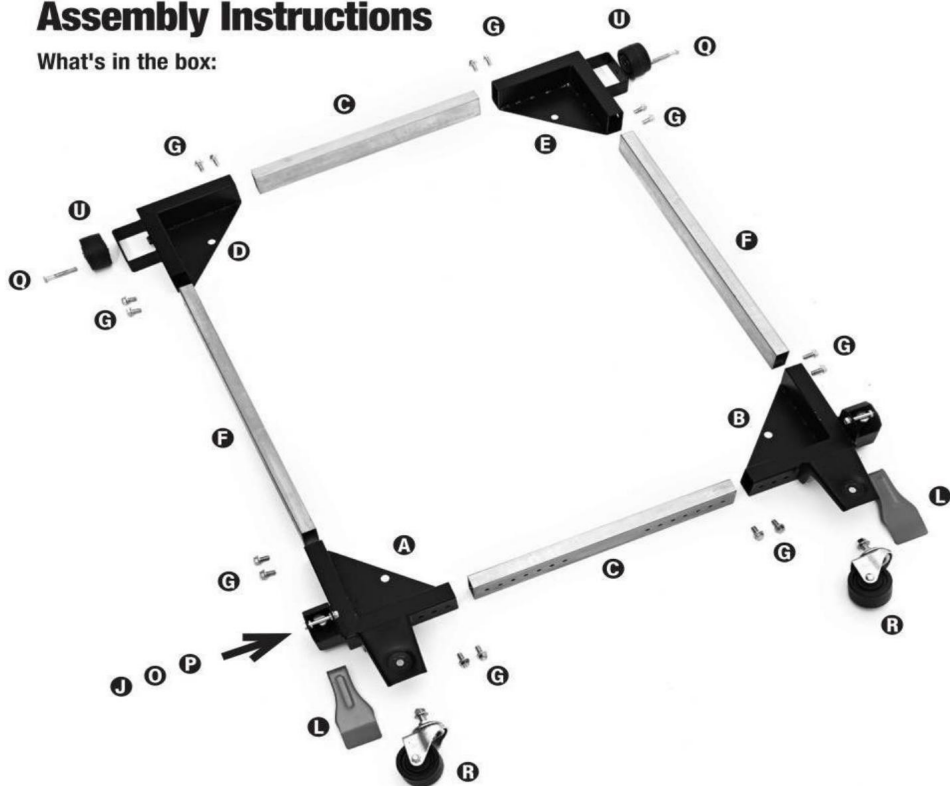

Step 1. Assemble front corners

1. Bolt foot lever **L** to base using part **J**, **O**, & **P**
2. Bolt swivel caster to base using part **S**



Step 2. Assemble back corners

1. Bolt wheel **U** to base using parts **K**, **T**, & **Q**

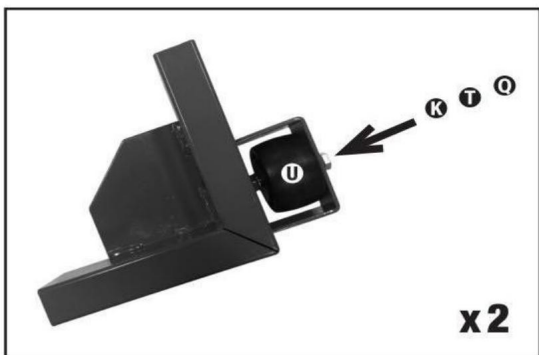

Step 3. Assemble side tubes

1. Bolt side tube between the front and back right corners using 4x part **G**
2. Bolt the tube out of the side of the front and back corner using 2x part **G** each



Step 4. Slide the machine onto the base

1. Slide your machine onto the mobile base before connecting the remaining corners

Step 5. Connect the remaining corners

1. Bolt side tube between the front and back right corners using 4x part **G**



2. Slide the left assembly onto the front and back rail – bolt it together using 4x part **G**



MANTENIMIENTO

1. Evitar la exposición prolongada al sol para evitar el envejecimiento.
2. Inspeccione los accesorios en busca de desgaste, grietas y otros daños antes de usarlos, y reemplace los accesorios defectuosos inmediatamente.

Fabricante: Shanghai muxin muyeyouxiangongsi

Dirección: Shuangchenglu 803nong11hao1602A-1609shi, baoshanqu, shanghai 200000 CN.

Importado a AUS: SIHAO PTY LTD, 1 ROKEVA STREET EASTWOOD NSW 2122 Australia

Importado a EE. UU.: Sanven Technology Ltd., Suite 250, 9166 Anaheim Place, Rancho Cucamonga, CA 91730

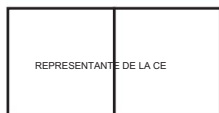

E-CrossStu GmbH

Mainzer Landstr.69, 60329 Fráncfort del Meno.

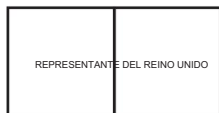

YH CONSULTING LIMITADO.

C/O YH Consulting Limited Oficina 147, Centurion House, London Road, Staines upon Thames, Surrey, TW18 4AX

VEVOR®
TOUGH TOOLS, HALF PRICE

Soporte técnico y certificado de garantía
electrónica www.vevor.com/support

VEVOR[®]

TOUGH TOOLS, HALF PRICE

Wsparcie techniczne i certyfikat e-gwarancji

www.vevor.com/support

BAZA MOBILNA

MODEL: GZB88094

Nadal dokładamy wszelkich starań, aby zapewnić Państwu narzędzia w konkurencyjnej cenie.

„Zaoszczędź o połowę”, „o połowę ceny” lub inne podobne wyrażenia używane przez nas przedstawiają jedynie szacunkową oszczędność, jaką możesz uzyskać kupując u nas określone narzędzia w porównaniu z głównymi najlepszymi markami i niekoniecznie oznaczają uwzględnienie wszystkich kategorii oferowanych narzędzi przez nas. Przypominamy, aby podczas składania zamówienia u nas dokładnie sprawdzić, czy faktycznie oszczędzasz połowę w porównaniu z czołowymi markami.

VEVOR[®]
TOUGH TOOLS, HALF PRICE

BAZA MOBILNA

MODEL: GZB88094



Zdjęcie w celach informacyjnych

POTRZEBUJESZ POMOCY? SKONTAKTUJ SIĘ Z NAMI!

Masz pytania dotyczące produktu? Potrzebujesz wsparcia technicznego? Prosimy o kontakt:
Wsparcie

techniczne i certyfikat e-gwarancji www.vevor.com/support

To jest oryginalna instrukcja. Przed przystąpieniem do obsługi prosimy o dokładne zapoznanie się ze wszystkimi instrukcjami. VEVOR zastrzega sobie jasną interpretację naszej instrukcji obsługi. Wygląd produktu zależy od produktu, który otrzymałeś. Proszę wybaczyć nam, że nie będziemy ponownie informować Państwa, jeśli pojawią się jakieś aktualizacje technologii lub oprogramowania naszego produktu.

INSTRUKCJE BEZPIECZEŃSTWA



OSTRZEŻENIE: Przeczytaj i zrozum tę instrukcję wcześniej montażu, instalacji, obsługi lub serwisowania tego produktu.

Niezastosowanie się do tych ostrzeżeń i instrukcji może spowodować śmierć, obrażenia ciała lub uszkodzenie cennego mienia.

1. Proszę nie umieszczać go w pobliżu materiałów łatwopalnych.
2. Zabrania się przewożenia osób w jakichkolwiek warunkach.
3. Tego produktu nie można używać do wchodzenia i schodzenia po schodach.
4. Przeciążanie jest surowo zabronione.
5. Nie poruszaj się zbyt szybko, mijając dziury.

ZACHOWAJ TE INSTRUKCJE

MODEL I PARAMETRY

Materiał: Q235

Rozmiar produktu: minimum 18 x 24 cale, maksymalnie 26,5 x 31,5 cala

Nośność: maks. 1500 funtów.

Uwaga: Dostosowując podstawę mobilną do maksymalnego rozmiaru instalacji, należy nie można używać przy maksymalnym obciążeniu.

Lista części:

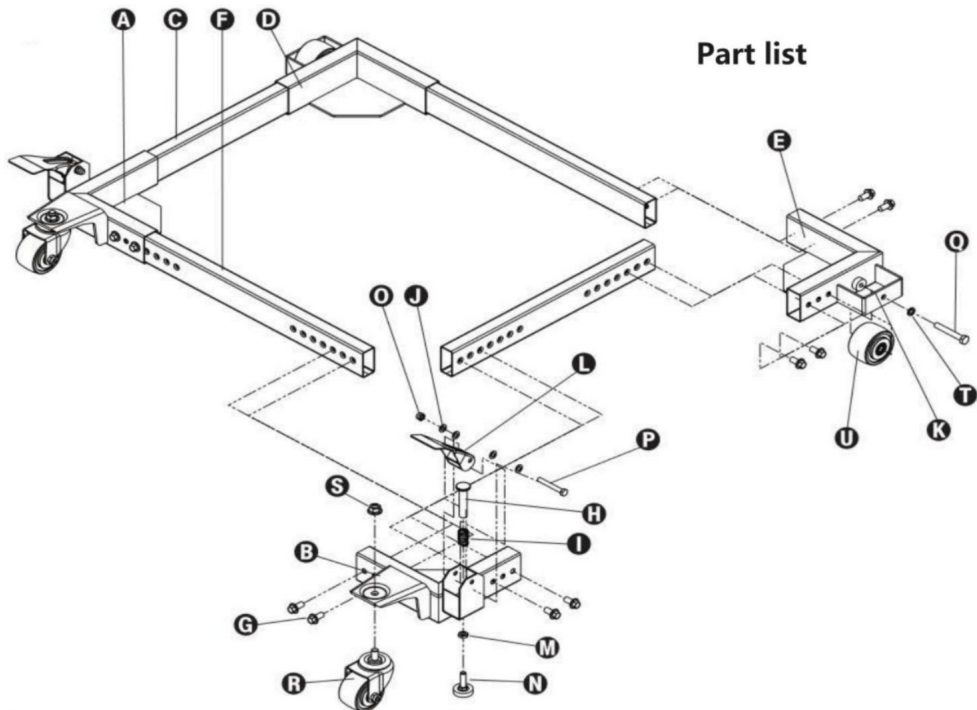

Part list

Lista części

S/N	Opis	Ilość	S/N	Opis	Ilość
	Lewy przedni róg	1		Dźwignia nożna	2
	Prawy przedni róg	1		Przeciwnakrętka M10	2
	Krótka rurka boczna	2		Gumowa stopka ślizgowa	2
	Tylny lewy róg	1		Nakrętka Nyloc M8 1 Śruba	2
	Prawy tylny róg			sześciokątna 8x60-15	2
	Rura boczna Lon9	2		10x 70 Śruba sześciokątna	2
	Śruba sześciokątna z kołnierzem			Kółko obrotowe 16 3 cale	2
M10x20	Trzpień dźwigni nożnej	2		Nakrętka kołnierzowa M12 2	2
	Sprężyna dźwigni nożnej			Podkładka zabezpieczająca M10	2
	Podkładka płaska M8	8		Koło 3".	2
	Podkładka płaska M10	2			

Safety Instructions for Mobile Bases

1. Be careful when moving to limit any finger pinch points.
2. Place base on a level surface and adjust levelers before placing the machine in position. This should keep the machine from rocking, while testing it for stability.
3. Test the stability in both the up (on the casters) and the down positions. Exercise caution when testing the stability of top heavy machines (drill presses, band saws, etc.).
4. Unplug any power tool before moving or repositioning your tool.
5. Always test your set-up for stability and safety after repositioning.
6. Care should be taken when planning the orientation of the machine onto the Universal Mobile Base. Transfer the weight off of the levelers to the casters will result in the machine tilting 1/2" toward the fixed wheels. When positioning top heavy tools such as a drill press or band saw, take advantage of the center of gravity, and position so that it will remain stable while on casters.
7. Never use your machine without engaging the floor locks and foot locks. Always lower the machine onto the non-skid levelers before operating.
8. When moving, always push the base, not the machine.

Assembly Examples

Be sure to follow safety and assembly instructions. Keep in mind the actual operation of your machine and the effect it has on overall stability.

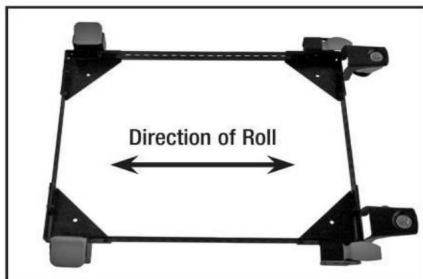

A long narrow base, such as on a jointer, would benefit from this arrangement. Most machines may be arranged to the convenience of the user.

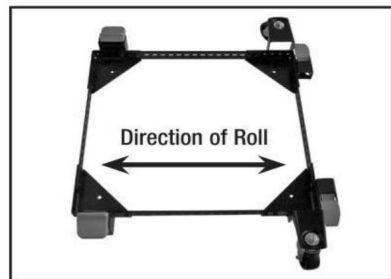

A short narrow base, such as found on a drill press or bandsaw may benefit from this arrangement. Due to swivel rotation, base may sit out of level. Rotate swivel wheel away from base to correct.

Safety Instructions for Mobile Bases

1. Be careful when moving to limit any finger pinch points.
2. Place base on a level surface and adjust levelers before placing the machine in position. This should keep the machine from rocking, while testing it for stability.
3. Test the stability in both the up (on the casters) and the down positions. Exercise caution when testing the stability of top heavy machines (drill presses, band saws, etc.).
4. Unplug any power tool before moving or repositioning your tool.
5. Always test your set-up for stability and safety after repositioning.
6. Care should be taken when planning the orientation of the machine onto the Universal Mobile Base. Transfer the weight off of the levelers to the casters will result in the machine tilting 1/2" toward the fixed wheels. When positioning top heavy tools such as a drill press or band saw, take advantage of the center of gravity, and position so that it will remain stable while on casters.
7. Never use your machine without engaging the floor locks and foot locks. Always lower the machine onto the non-skid levelers before operating.
8. When moving, always push the base, not the machine.

Assembly Examples

Be sure to follow safety and assembly instructions. Keep in mind the actual operation of your machine and the effect it has on overall stability.

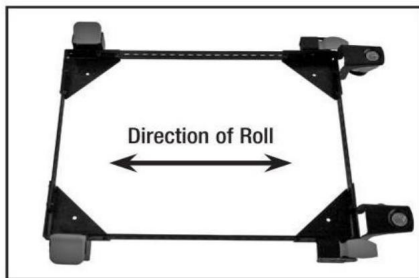

A long narrow base, such as on a jointer, would benefit from this arrangement. Most machines may be arranged to the convenience of the user.

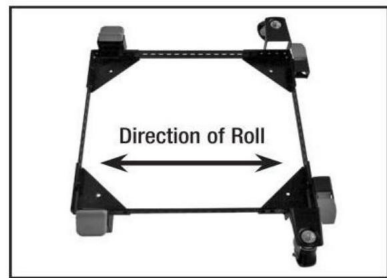

A short narrow base, such as found on a drill press or bandsaw may benefit from this arrangement. Due to swivel rotation, base may sit out of level. Rotate swivel wheel away from base to correct.

Assembly Instructions

What's in the box:

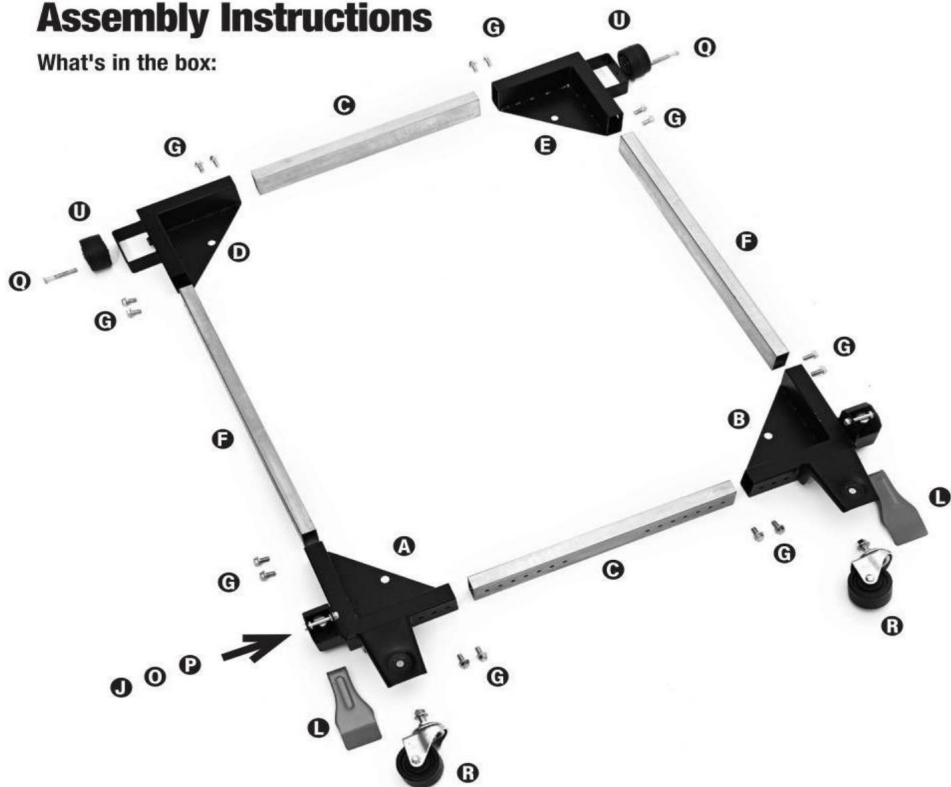

Step 1. Assemble front corners

1. Bolt foot lever **L** to base using part **J**, **O**, & **P**
2. Bolt swivel caster to base using part **S**



Step 2. Assemble back corners

1. Bolt wheel **U** to base using parts **K**, **T**, & **Q**

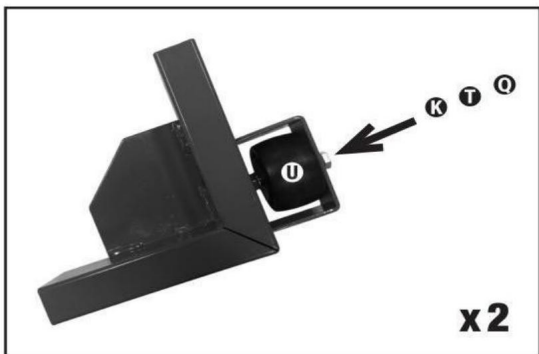

Step 3. Assemble side tubes

1. Bolt side tube between the front and back right corners using 4x part **G**
2. Bolt the tube out of the side of the front and back corner using 2x part **G** each



Step 4. Slide the machine onto the base

1. Slide your machine onto the mobile base before connecting the remaining corners

Step 5. Connect the remaining corners

1. Bolt side tube between the front and back right corners using 4x part **G**



2. Slide the left assembly onto the front and back rail – bolt it together using 4x part **G**



KONSERWACJA

1. Unikaj długotrwałej ekspozycji na słońce, aby uniknąć starzenia.
2. Przed użyciem sprawdź akcesoria pod kątem zużycia, pęknięć i innych uszkodzeń oraz natychmiast wymień wadliwe akcesoria.

Producent: Shanghai muxinmuyeyouxiangongsi

Adres: Shuangchenglu 803nong11hao1602A-1609shi, baoshanqu, szanghaj
200000 CN.

Import do AUS: SIHAO PTY LTD, 1 ROKEVA STREET EASTWOOD NSW
2122 Australii

Import do USA: Sanven Technology Ltd., Suite 250, 9166 Anaheim Place, Rancho
Cucamonga, CA 91730

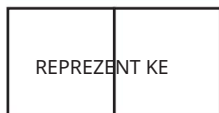

E-CrossStu GmbH

Mainzer Landstr.69, 60329 Frankfurt nad Menem.



YH CONSULTING SPÓŁKA Z OGRANICZONĄ ODPOWIEDZIALNOŚCIĄ.

C/O YH Consulting Limited Office 147, Centurion House,
London Road, Staines-upon-Thames, Surrey, TW18 4AX

VEVOR®
TOUGH TOOLS, HALF PRICE

Wsparcie techniczne i certyfikat e-gwarancji
www.vevor.com/support

VEVOR[®]

TOUGH TOOLS, HALF PRICE

Technische ondersteuning en e-garantiecertificaat

www.vevor.com/support

MOBIELE BASIS

MODEL: GZB88094

Wij blijven ons inzetten om u gereedschap te bieden tegen een concurrerende prijs.

'Bespaar de helft', 'Halve prijs' of andere soortgelijke uitdrukkingen die door ons worden gebruikt vertegenwoordigen slechts een schatting van de besparingen die u zou kunnen profiteren als u bepaalde gereedschappen bij ons koopt in vergelijking met de grote topmerken en betekenen niet noodzakelijkerwijs dat ze alle aangeboden categorieën gereedschappen dekken. door ons. U wordt er vriendelijk aan herinnerd om bij het plaatsen van een bestelling bij

ons zorgvuldig te verifiëren of u daadwerkelijk de helft bespaart in vergelijking met de grote topmerken.

VEVOR[®]

TOUGH TOOLS, HALF PRICE

MOBIELE BASIS

MODEL: GZB88094



Foto ter referentie

HULP NODIG? NEEM CONTACT MET ONS OP!

Heeft u productvragen? Technische ondersteuning nodig? Neem gerust contact met ons op:

Technische

**ondersteuning en e-garantiecertificaat [www.vevor.com/
support](http://www.vevor.com/support)**

Dit is de originele instructie. Lees alle instructies in de handleiding zorgvuldig door voordat u ermee aan de slag gaat. VEVOR behoudt zich een duidelijke interpretatie van onze gebruikershandleiding voor. Het uiterlijk van het product is afhankelijk van het product dat u heeft ontvangen. Vergeef ons alstublieft dat we u niet opnieuw zullen informeren als er technologie- of software-updates zijn voor ons product.

VEILIGHEIDSIINSTRUCTIES



WAARSCHUWING: Lees en begrijp eerst deze handleiding assembleren, installeren, bedienen of onderhouden van dit product.

Het niet opvolgen van deze waarschuwingen en instructies kan leiden tot overlijden, persoonlijk letsel of schade aan waardevolle eigendommen.

1. Plaats het niet in de buurt van brandbare materialen.
2. Het is onder geen enkele omstandigheid verboden mensen te vervoeren.
3. Dit product kan niet worden gebruikt om trappen op of af te gaan.
4. Overbelasting is ten strengste verboden.
5. Beweeg niet te snel bij het passeren van kuilen.

BEWAAR DEZE INSTRUCTIES

MODEL EN PARAMETERS

Materiaal: Q235

Productgrootte: minimaal 18x24 inch, maximaal 26,5x31,5 inch

Laadvermogen: maximaal 1500 kg.

Let op: Wanneer u de mobiele basis afstelt op de maximale installatiegrootte, kan deze kan niet worden gebruikt met het maximale draagvermogen.

Onderdelenlijst:

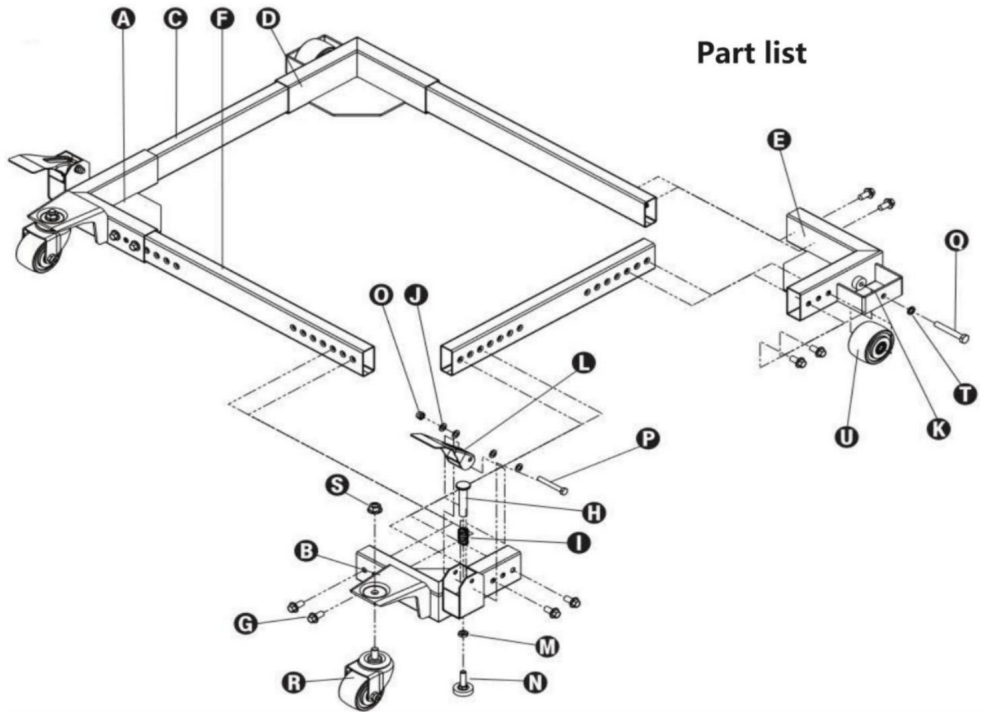

Part list

Onderdelenlijst					
S/N	Beschrijving	Aantal	S/	Beschrijving	Aantal
ÿ	Linkervoorhoek	N 1	ÿ	Voethendel	2
ÿ	Rechtervoorhoek	1	ÿ	M10 contraoer	2
ÿ	Korte zijbuis	2	ÿ	Rubberen glijvoet	2
ÿ	Linkerhoek achteraan	1	ÿ	M8 Nyloc-moer	1
ÿ	Rechterachterhoek	8x60-15	ÿ	zeskantbout	2
ÿ	Lon9 zijbuis	2	ÿ	10x 70 zeskantbout	2
ÿ	M10x20 geflensde zeskantbout	16	ÿ	3" zwenkwiel	2
ÿ	Voethefboomplunjer	2	ÿ	M12 flensmoer	2
ÿ	Voethendelveer	borgring			2
ÿ	M8 platte sluitring	8	ÿ	3" wiel	2
ÿ	M10 platte sluitring	2			

Safety Instructions for Mobile Bases

1. Be careful when moving to limit any finger pinch points.
2. Place base on a level surface and adjust levelers before placing the machine in position. This should keep the machine from rocking, while testing it for stability.
3. Test the stability in both the up (on the casters) and the down positions. Exercise caution when testing the stability of top heavy machines (drill presses, band saws, etc.).
4. Unplug any power tool before moving or repositioning your tool.
5. Always test your set-up for stability and safety after repositioning.
6. Care should be taken when planning the orientation of the machine onto the Universal Mobile Base. Transfer the weight off of the levelers to the casters will result in the machine tilting 1/2" toward the fixed wheels. When positioning top heavy tools such as a drill press or band saw, take advantage of the center of gravity, and position so that it will remain stable while on casters.
7. Never use your machine without engaging the floor locks and foot locks. Always lower the machine onto the non-skid levelers before operating.
8. When moving, always push the base, not the machine.

Assembly Examples

Be sure to follow safety and assembly instructions. Keep in mind the actual operation of your machine and the effect it has on overall stability.

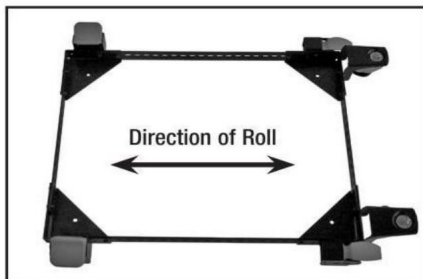

A long narrow base, such as on a jointer, would benefit from this arrangement. Most machines may be arranged to the convenience of the user.

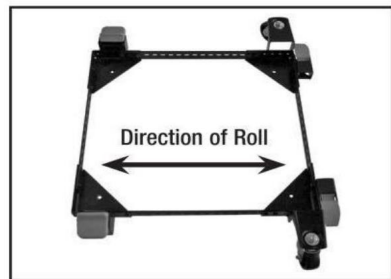

A short narrow base, such as found on a drill press or bandsaw may benefit from this arrangement. Due to swivel rotation, base may sit out of level. Rotate swivel wheel away from base to correct.

Safety Instructions for Mobile Bases

1. Be careful when moving to limit any finger pinch points.
2. Place base on a level surface and adjust levelers before placing the machine in position. This should keep the machine from rocking, while testing it for stability.
3. Test the stability in both the up (on the casters) and the down positions. Exercise caution when testing the stability of top heavy machines (drill presses, band saws, etc.).
4. Unplug any power tool before moving or repositioning your tool.
5. Always test your set-up for stability and safety after repositioning.
6. Care should be taken when planning the orientation of the machine onto the Universal Mobile Base. Transfer the weight off of the levelers to the casters will result in the machine tilting 1/2" toward the fixed wheels. When positioning top heavy tools such as a drill press or band saw, take advantage of the center of gravity, and position so that it will remain stable while on casters.
7. Never use your machine without engaging the floor locks and foot locks. Always lower the machine onto the non-skid levelers before operating.
8. When moving, always push the base, not the machine.

Assembly Examples

Be sure to follow safety and assembly instructions. Keep in mind the actual operation of your machine and the effect it has on overall stability.

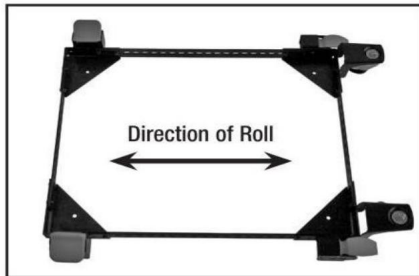

A long narrow base, such as on a jointer, would benefit from this arrangement. Most machines may be arranged to the convenience of the user.

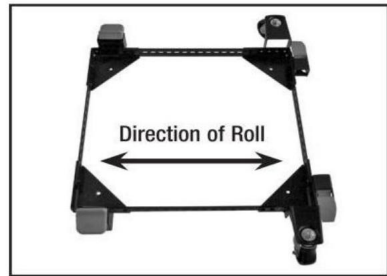

A short narrow base, such as found on a drill press or bandsaw may benefit from this arrangement. Due to swivel rotation, base may sit out of level. Rotate swivel wheel away from base to correct.

Assembly Instructions

What's in the box:

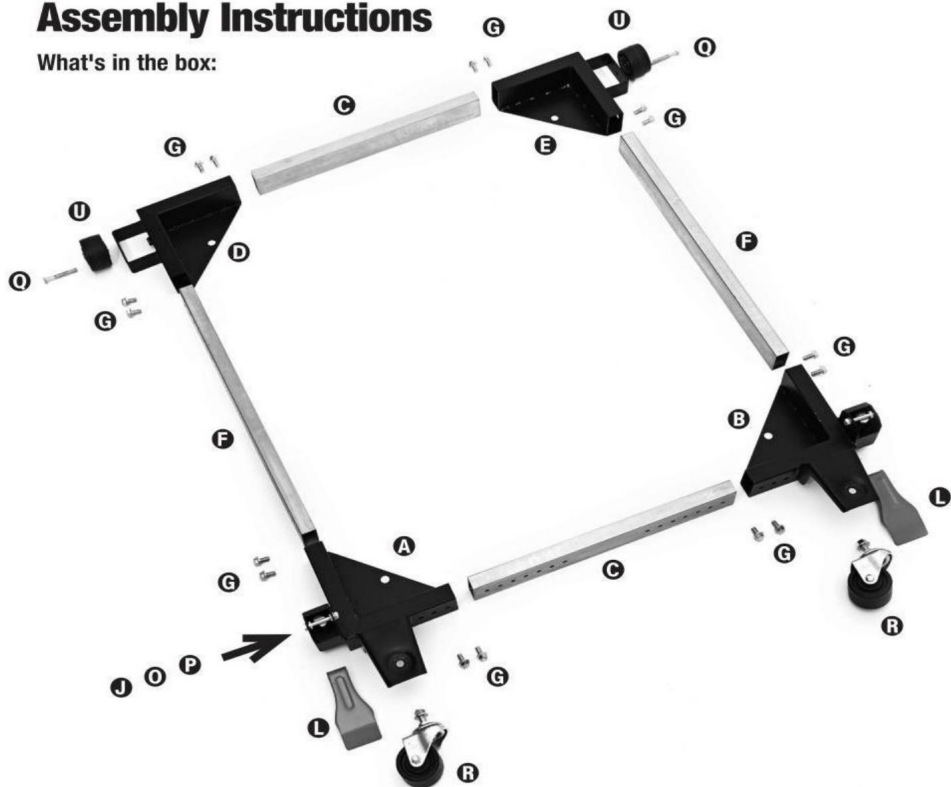

Step 1. Assemble front corners

1. Bolt foot lever **L** to base using part **J**, **O**, & **P**
2. Bolt swivel caster to base using part **S**



Step 2. Assemble back corners

1. Bolt wheel **U** to base using parts **K**, **T**, & **Q**

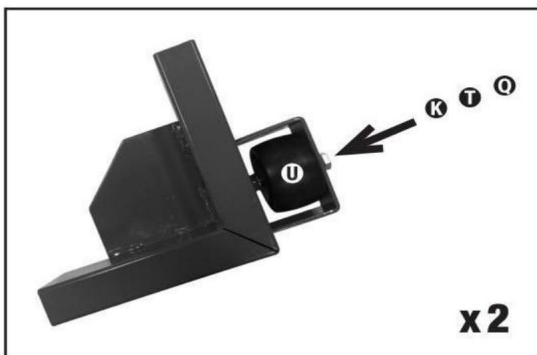

Step 3. Assemble side tubes

1. Bolt side tube between the front and back right corners using 4x part **G**
2. Bolt the tube out of the side of the front and back corner using 2x part **G** each



Step 4. Slide the machine onto the base

1. Slide your machine onto the mobile base before connecting the remaining corners

Step 5. Connect the remaining corners

1. Bolt side tube between the front and back right corners using 4x part **G**



2. Slide the left assembly onto the front and back rail – bolt it together using 4x part **G**



ONDERHOUD

1. Vermijd langdurige blootstelling aan de zon om veroudering te voorkomen.
2. Inspecteer de accessoires vóór gebruik op slijtage, scheuren en andere schade, en vervang defecte accessoires onmiddellijk.

Fabrikant: Shanghaimuxinmuyeyouxiangongsi

Adres: Shuangchenglu 803nong11hao1602A-1609shi, baoshanqu, shanghai 200000 CN.

Geïmporteerd naar AUS: SIHAO PTY LTD, 1 ROKEVA STREETEASTWOOD NSW 2122 Australië

Geïmporteerd naar de VS: Sanven Technology Ltd., Suite 250, 9166 Anaheim Place, Rancho Cucamonga, CA 91730



E-CrossStu GmbH
Mainzer Landstr.69, 60329 Frankfurt am Main.



YH CONSULTING LIMITED.
C/O YH Consulting Limited Kantoor 147, Centurion House,
London Road, Staines-upon-Thames, Surrey, TW18 4AX

VEVOR[®]
TOUGH TOOLS, HALF PRICE

Technische ondersteuning en e-
garantiecertificaat www.vevor.com/support

VEVOR[®]

TOUGH TOOLS, HALF PRICE

Teknisk support och e-garanticertifikat

www.vevor.com/support

MOBIL BAS

MODELL: GZB88094

Vi fortsätter att vara engagerade i att ge dig verktyg till konkurrenskraftiga priser.

"Spara hälften", "halva priset" eller andra liknande uttryck som används av oss representerar bara en uppskattning av besparingar du kan dra nytta av att köpa vissa verktyg hos oss jämfört med de stora toppmärkena och betyder inte nödvändigtvis att täcka alla kategorier av verktyg som erbjuds av oss. Du påminns vänligen om att noggrant kontrollera när du gör en beställning hos oss om du faktiskt sparar hälften i jämförelse med de främsta stora varumärkena.

VEVOR®

TOUGH TOOLS, HALF PRICE

MOBIL BAS

MODELL: GZB88094



Foto för referens

BEHÖVER HJÄLP? KONTAKTA OSS!

Har du produktfrågor? Behöver du teknisk support? Kontakta oss gärna: **Teknisk support och e-garanticertifikat www.vevor.com/support**

Detta är den ursprungliga instruktionen, läs alla instruktioner noggrant innan du använder den. VEVOR reserverar sig för en tydlig tolkning av vår användarmanual. Utseendet på produkten är beroende av den produkt du fått. Ursäkta oss att vi inte kommer att informera dig igen om det finns någon teknik eller mjukvaruuppdateringar på vår produkt.

SÄKERHETSINSTRUKTIONER



VARNING: Läs och förstå denna manual innan

montering, installation, drift eller service av denna produkt.

Underlåtenhet att följa dessa varningar och instruktioner kan orsaka dödsfall, personskada eller skada på värdefull egendom.

1. Placera den inte nära brandfarliga material.
2. Det är förbjudet att transportera människor under alla förhållanden.
3. Denna produkt kan inte användas för att gå upp eller ner för trappor.
4. Överbelastning är strängt förbjuden.
5. Rör dig inte för snabbt när du passerar gropar.

SPARA DESSA INSTRUKTIONER

MODELL OCH PARAMETRAR

Material: Q235

Produktstorlek: Minst 18x24 tum, max 26,5x31,5 tum

Lastkapacitet: max 1500 lbs.

Obs: När du justerar den mobila basen till den maximala installationsstorleken ska den inte användas med maximal lastkapacitet.

Dellista:

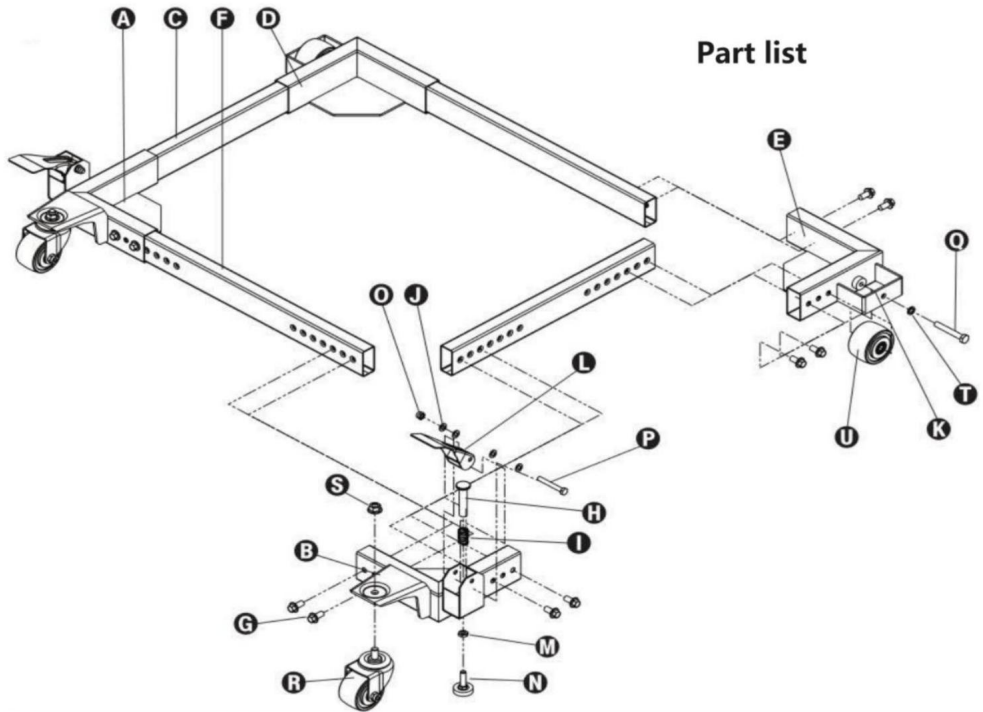

Part list

Delarlista

S/N	Beskrivning	Antal	S/N	Beskrivning	Antal
ÿ	Främre vänstra hörnet	1 ÿ		Fotspak	2
ÿ	Främre högra hörnet	1 ÿ	M10 syltmutter		2
ÿ	Kort sidorör	2 ÿ	Gummiglidfot		2
ÿ	Bakre vänstra hörnet	1 ÿ	M8 nylokmutter 1 ÿ		2
ÿ	Bakre högra hörnet	8x60-15	sexkantsbult		2
ÿ	Lon9 sidorör	2 ÿ	10x 70 sexkantsbult		2
ÿ	M10x20 Flänsad sexkantsbult	16 ÿ	3" svängbara hjul		2
	Fotspakskolv	2 ÿ	M12 flänsmutter 2 ÿ	M10	2
ÿ	Fotspaksfjäder	Låsbricka			2
ÿ	M8 platt bricka	8 ÿ		3" hjul	2
ÿ	M10 platt bricka	2			

Safety Instructions for Mobile Bases

1. Be careful when moving to limit any finger pinch points.
2. Place base on a level surface and adjust levelers before placing the machine in position. This should keep the machine from rocking, while testing it for stability.
3. Test the stability in both the up (on the casters) and the down positions. Exercise caution when testing the stability of top heavy machines (drill presses, band saws, etc.).
4. Unplug any power tool before moving or repositioning your tool.
5. Always test your set-up for stability and safety after repositioning.
6. Care should be taken when planning the orientation of the machine onto the Universal Mobile Base. Transfer the weight off of the levelers to the casters will result in the machine tilting 1/2" toward the fixed wheels. When positioning top heavy tools such as a drill press or band saw, take advantage of the center of gravity, and position so that it will remain stable while on casters.
7. Never use your machine without engaging the floor locks and foot locks. Always lower the machine onto the non-skid levelers before operating.
8. When moving, always push the base, not the machine.

Assembly Examples

Be sure to follow safety and assembly instructions. Keep in mind the actual operation of your machine and the effect it has on overall stability.

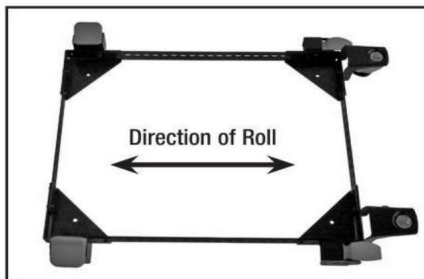

A long narrow base, such as on a jointer, would benefit from this arrangement. Most machines may be arranged to the convenience of the user.

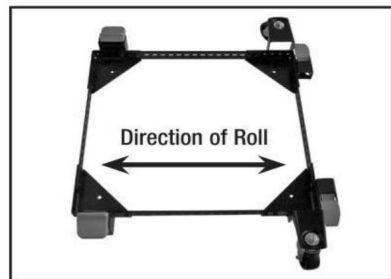

A short narrow base, such as found on a drill press or bandsaw may benefit from this arrangement. Due to swivel rotation, base may sit out of level. Rotate swivel wheel away from base to correct.

Safety Instructions for Mobile Bases

1. Be careful when moving to limit any finger pinch points.
2. Place base on a level surface and adjust levelers before placing the machine in position. This should keep the machine from rocking, while testing it for stability.
3. Test the stability in both the up (on the casters) and the down positions. Exercise caution when testing the stability of top heavy machines (drill presses, band saws, etc.).
4. Unplug any power tool before moving or repositioning your tool.
5. Always test your set-up for stability and safety after repositioning.
6. Care should be taken when planning the orientation of the machine onto the Universal Mobile Base. Transfer the weight off of the levelers to the casters will result in the machine tilting 1/2" toward the fixed wheels. When positioning top heavy tools such as a drill press or band saw, take advantage of the center of gravity, and position so that it will remain stable while on casters.
7. Never use your machine without engaging the floor locks and foot locks. Always lower the machine onto the non-skid levelers before operating.
8. When moving, always push the base, not the machine.

Assembly Examples

Be sure to follow safety and assembly instructions. Keep in mind the actual operation of your machine and the effect it has on overall stability.

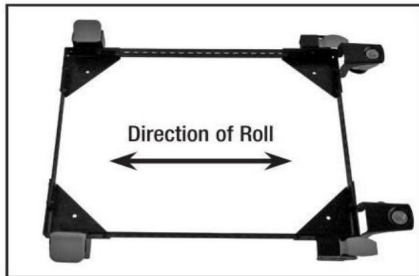

A long narrow base, such as on a jointer, would benefit from this arrangement. Most machines may be arranged to the convenience of the user.

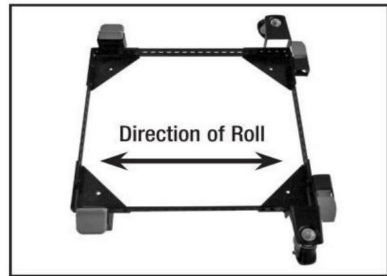

A short narrow base, such as found on a drill press or bandsaw may benefit from this arrangement. Due to swivel rotation, base may sit out of level. Rotate swivel wheel away from base to correct.

Assembly Instructions

What's in the box:

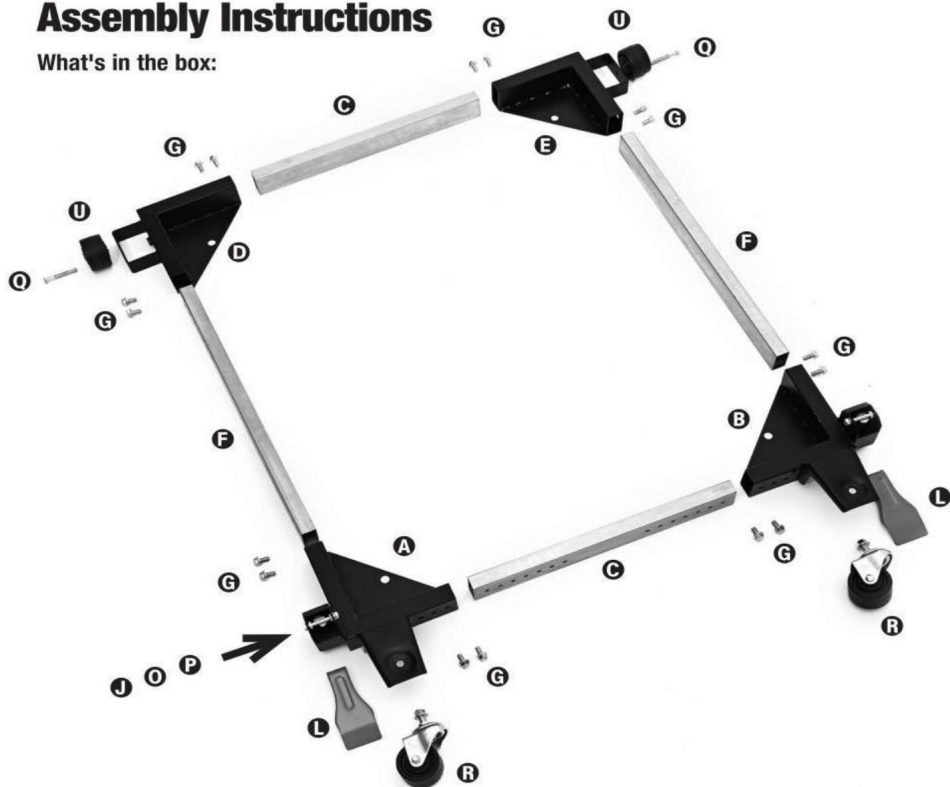

Step 1. Assemble front corners

1. Bolt foot lever **L** to base using part **J**, **O**, & **P**
2. Bolt swivel caster to base using part **S**



Step 2. Assemble back corners

1. Bolt wheel **U** to base using parts **K**, **T**, & **Q**

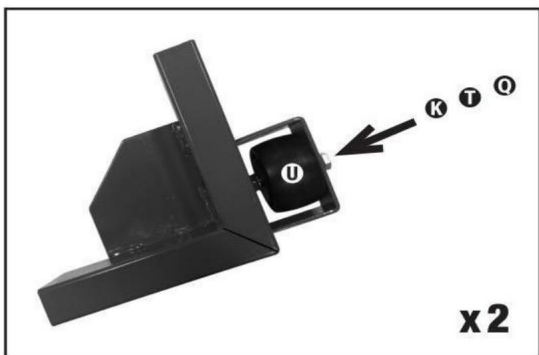

Step 3. Assemble side tubes

1. Bolt side tube between the front and back right corners using 4x part **G**
2. Bolt the tube out of the side of the front and back corner using 2x part **G** each



Step 4. Slide the machine onto the base

1. Slide your machine onto the mobile base before connecting the remaining corners

Step 5. Connect the remaining corners

1. Bolt side tube between the front and back right corners using 4x part **G**



2. Slide the left assembly onto the front and back rail – bolt it together using 4x part **G**



UNDERHÅLL

1. Undvik långvarig exponering för solen för att undvika åldrande.
2. Inspektera tillbehören för slitage, sprickor och andra skador före användning, och byt ut defekta tillbehör omedelbart.

Tillverkare: Shanghaimuxinmuyeyouxiangongsi

Adress: Shuangchenglu 803nong11hao1602A-1609shi, baoshanqu, shanghai 200000 CN.

Importerad till AUS: SIHAO PTY LTD, 1 ROKEVA STREETEASTWOOD NSW 2122 Australien

Importerad till USA: Sanven Technology Ltd., Suite 250, 9166 Anaheim Place, Rancho Cucamonga, CA 91730



E-CrossStu GmbH

Mainzer Landstr.69, 60329 Frankfurt am Main.



YH CONSULTING LIMITED.

C/O YH Consulting Limited Office 147, Centurion House, London Road, Staines-upon-Thames, Surrey, TW18 4AX

VEVOR®
TOUGH TOOLS, HALF PRICE

Teknisk support och e-garanticertifikat
www.vevor.com/support