

# **VEVOR<sup>®</sup>**

## **TOUGH TOOLS, HALF PRICE**

Technical Support and E-Warranty Certificate [www.vevor.com/support](http://www.vevor.com/support)

### **PEGBBOARD**

### **USER MANUAL**

We continue to be committed to provide you tools with competitive price.

"Save Half", "Half Price" or any other similar expressions used by us only represents an estimate of savings you might benefit from buying certain tools with us compared to the major top brands and does not necessarily mean to cover all categories of tools offered by us. You are kindly reminded to verify carefully when you are placing an order with us if you are actually saving half in comparison with the top major brands.

# VEVOR<sup>®</sup>

TOUGH TOOLS, HALF PRICE

## PEGBOARD

MODEL:HB641601,HB641602,HB9632

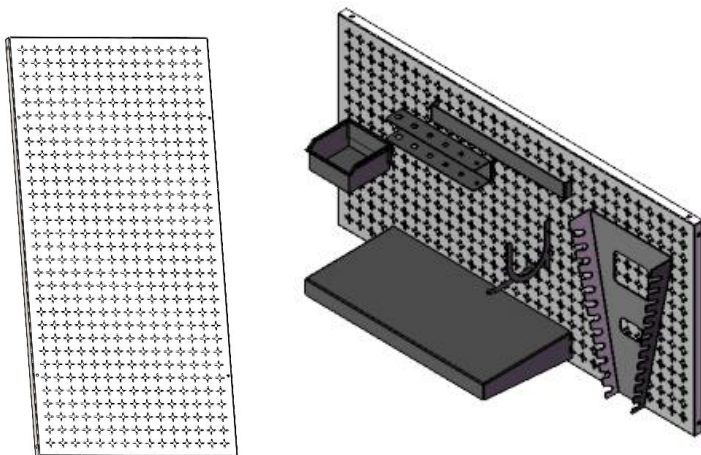

### NEED HELP? CONTACT US!

Have product questions? Need technical support? Please feel free to contact us:

**Technical Support and E-Warranty Certificate**  
[www.vevor.com/support](http://www.vevor.com/support)

This is the original instruction, please read all manual instructions carefully before operating. VEVOR reserves a clear interpretation of our user manual. The appearance of the product shall be subject to the product you received. Please forgive us that we won't inform you again if there are any technology or software updates on our product.

## SAFETY INSTRUCTIONS



### **WARNING:**

1. Read this material before using this product. Failure to do so can result in serious injury.
2. Do not exceed working capacity for pallet fork.
3. After use, please dry before storage to avoid rusting of product.
4. Procedures not specifically explained in this manual must be performed only by a qualified technician.

### **To prevent serious injury from tool failure, do not use when it is damaged:**

The pegboard must be mounted on a solid wall.

The pegboards shall not be installed on too thin wooden walls.

The pegboards shall not be installed on rotten or loose wooden walls.

The weight of the items to be hung shall not exceed the load of the pegboard.

When replacing the hook, it must be selected to match the size of the pegboard.

Avoid sharp points, blades, and other items to scratch the product



### **CAUTION:**

**Carefully read instructions and procedures for safe operations.**

**Save This Manual**

## MODEL AND PARAMETERS

<b>Model SPEC.</b>	HB641601	HB641602	HB9632
Material	Steel	Steel	Steel
Max.Weight Capacity (single pegboard)	165lbs	165lbs	165lbs
Pegboard Size(L*W)	32" *16"	32" *16"	32" *16"
Hole Spec.	1/4"	1/4"	1/4"
Sheet Thickness	1.0mm	1.0mm	1.0mm
Surface Treatment (pegboard)	Galvanization+Powder Spraying	Galvanization+Powder Spraying	Galvanization+Powder Spraying
Color	white	white	white

## COMPONENTS

Model Parts	HB641601	HB641602	HB9632
Pegboard	×2	×2	×3
Hook	/	×15	×20
Storage Box	/	×5	×5
Storage Box Holder	/	×5	×5
Screwdriver Holder	/	×1	×1
Rack	/	×1	×1
Shelf	/	×1	×2
Mounting Block	/	×6	×8
U Hook	/	/	×4
Wrench Holder	/	/	×1
Limit Plug	/	×8	×12
Expansion Plug	×8	×12	×16
Self-tapping Screw	×8	×12	×16
Positioning Cardboard	/	×1	×1
User's Manual	×1	×1	×1

## INSTALLATION INSTRUCTION

### Installation Preparation:

1. Two or more people to assemble the pegboard.
2. Please prepare a carpet or mat to protect your floor you need to spread out all the accessories.
3. Please prepare gloves to avoid being scratched by sharp parts that may occur during installation.
4. Please open all the boxes to check if the accessories are complete and in good condition.
5. If you need to use power tools to install this product, please set the speed to low speed in advance.
6. When installing, please align all the holes and do not tighten all the screws first, otherwise, it may make the installation difficult.

### For Concrete Wall Installation

**STEP 1:** Place the hanging board near the installed wall and mark the holes with a fine nail or pencil.(Note:Two holes on the left, two holes on the right)

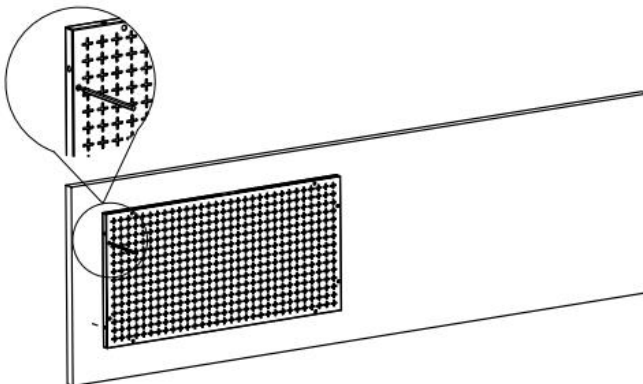

**STEP 2:** Drill holes 8mm in diameter and 40mm in depth at the marked places. (Note: Prepare your own drilling tools.)

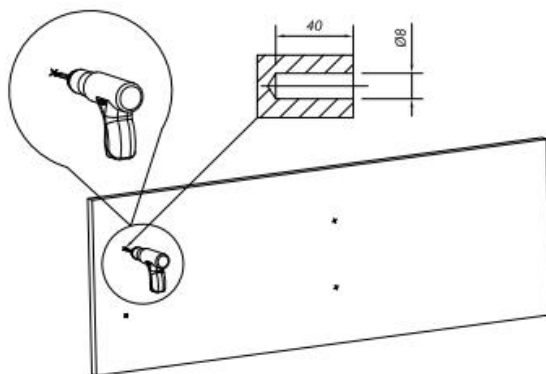

**STEP 3:** Nail the four expansion plugs completely into the hole.

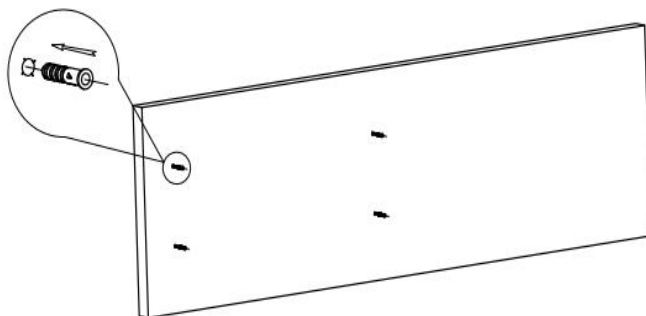

**STEP 4:** Screw the self-tapping screw into the expansion plug hole, leaving 3~5mm exposed.

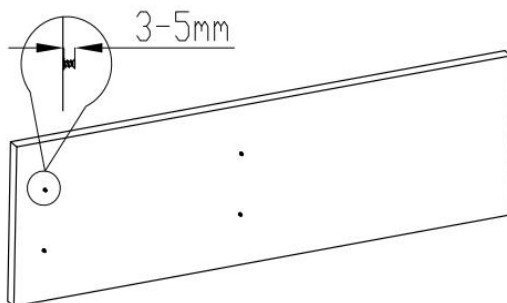

**STEP 5:** Hang the pegboard on the self-tapping screws, as shown in the picture.

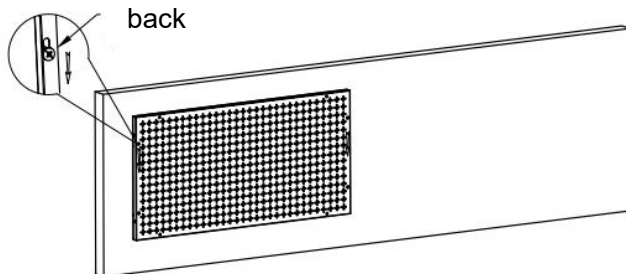

**STEP 6:** Ensure that the four self-tapping screws are hung into the mounting holes of the pegboard and tighten the self-tapping screws.

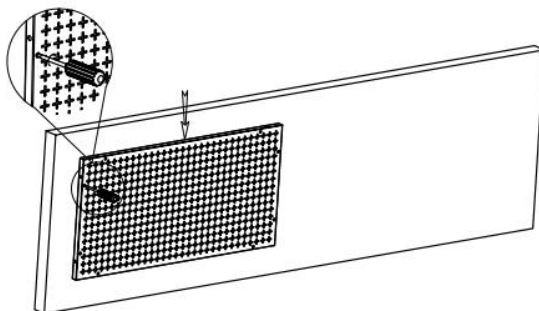

**STEP 7:** Follow the steps above to install other pegboards.  
(Note: The pegboard is placed horizontally and vertically, and the installation method is the same.)

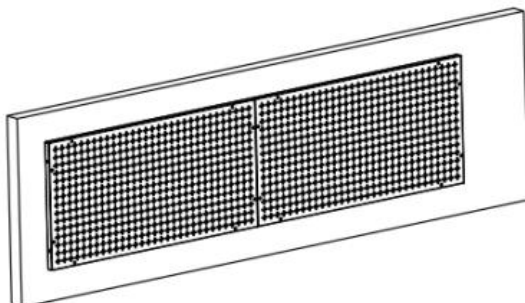



## For Wooden Wall Post Installation

**STEP 1:** Align edge of pegboard with center-line of post, and mark the holes with a fine nail or pencil. (Note: Two holes on the left, two holes on the right)

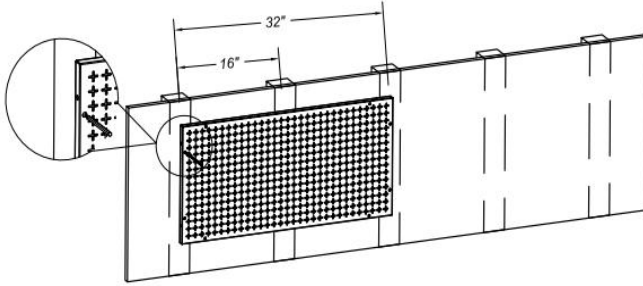

**STEP 2:** Drill holes 3mm in diameter and 40mm in depth at the marked places, screw the self-tapping screw into the holes, leaving 3~5mm exposed. (Note: Prepare your own tools.)

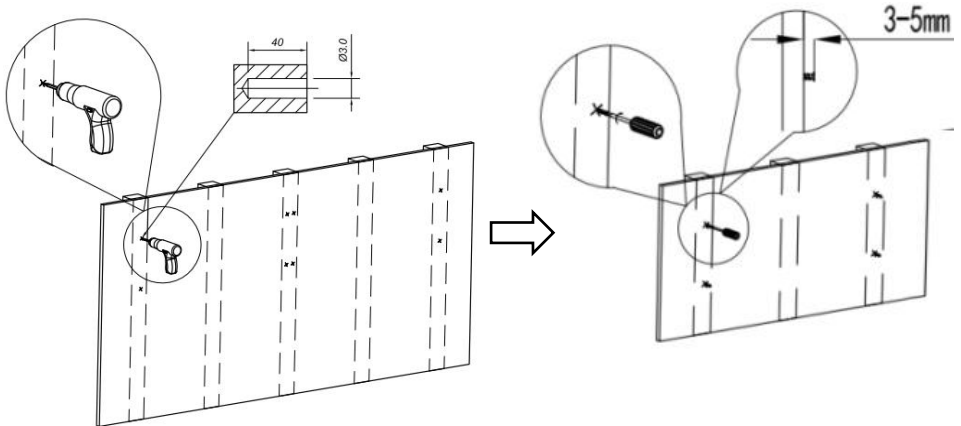

**STEP 3:** Hang the pegboard on the self-tapping screws, as shown in the picture.

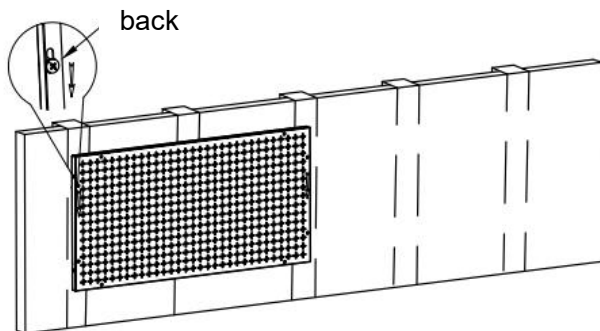

**STEP 4:** Ensure that the four self-tapping screws are hung into the mounting holes of the pegboard and tighten the self-tapping screws.

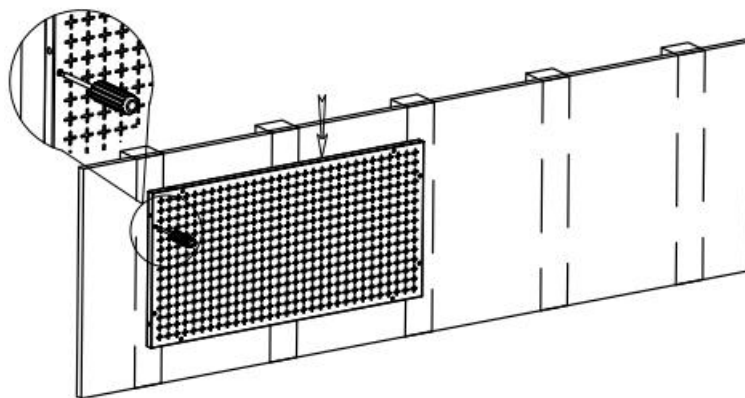

**STEP 5:** Follow the steps above to install other pegboards.  
(Note: The pegboard is placed horizontally and vertically, and the installation method is the same.)

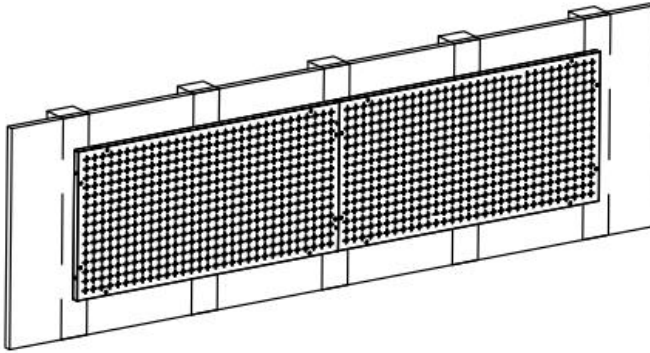

## For Mounting Block + Concrete Wall Installation

**STEP 1:** Lay the positioning cardboard on the wall to be installed, drill the marking holes according to the holes marked on the positioning cardboard. Take away cardboard and drill holes 8mm in diameter and 40mm in depth at the marking holes. (Note: Prepare your own drilling tools.) Nail the expansion plugs completely into the hole.

Vertical:  $A=406\text{mm}$

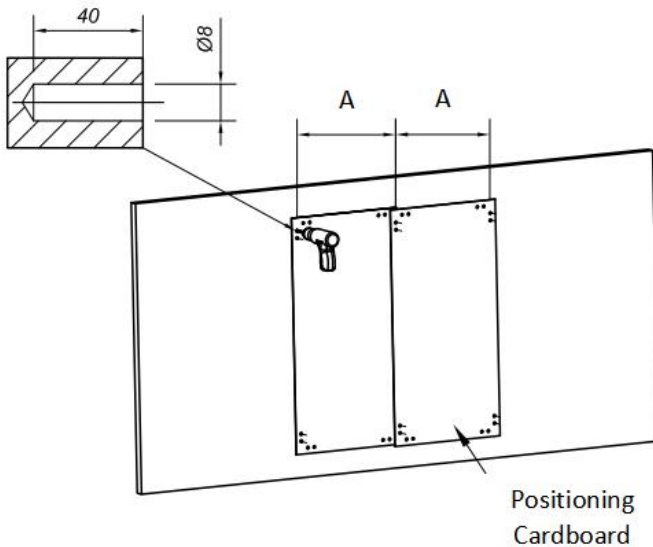

Horizontal: B=814mm

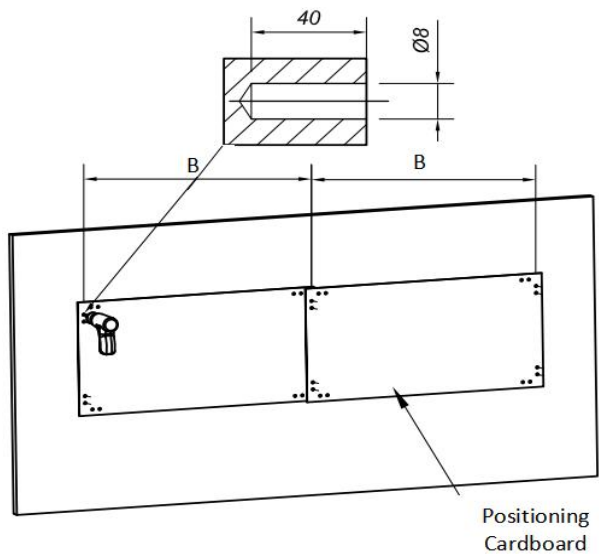

**STEP 2:** Fix the mounting block with self-tapping screws as shown(Vertical).

Note:Horizontal and vertical installation method is the same.

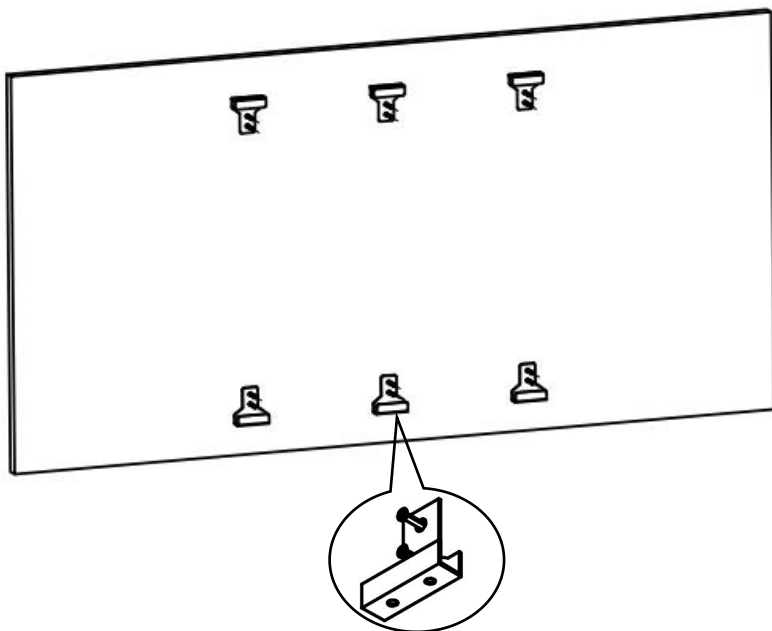

**STEP 3:** Insert the hanging plate into the mounting block and plug the limit plug as shown.

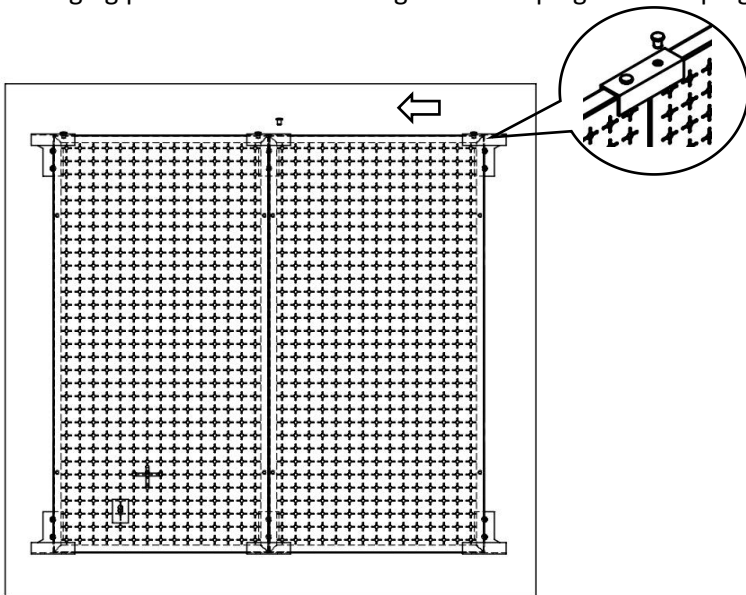

**STEP 4:** Follow the steps above to install other pegboards.

When the installation is complete, you can hang your items.

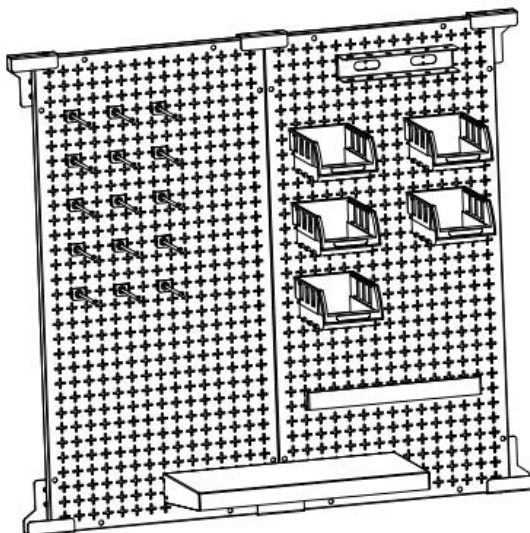

## For Mounting Block + Wooden Wall Post Installation

**STEP 1:** Lay the positioning cardboard on the wall to be installed, and the center of the hole on cardboard is located on the center-line of post.

Drill the marking holes according to the holes marked on the positioning cardboard.

Take away cardboard and drill holes 3mm in diameter and 40mm in depth at the marking holes. (Note: Prepare your own drilling tools.)

Vertical:  $A=406\text{mm}$

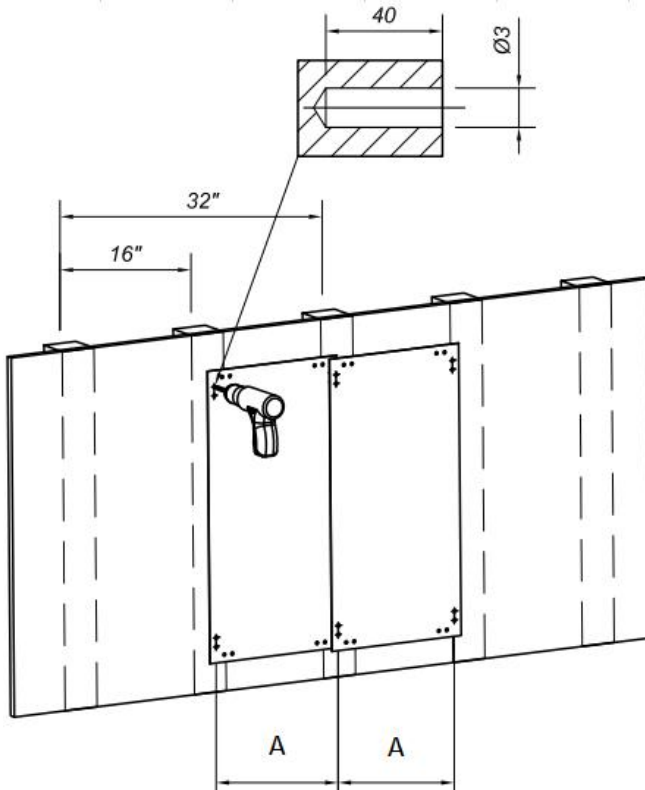

Horizontal: B=814mm

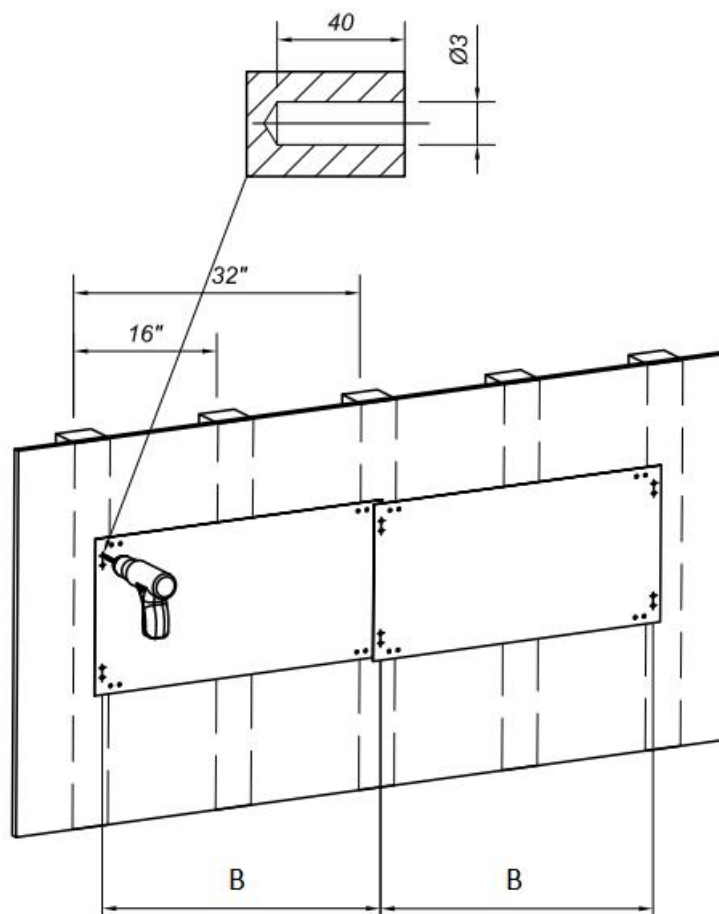

**STEP 2:** Fix the mounting block with self-tapping screws as shown(Vertical).

Note:Horizontal and vertical installation method is the same.

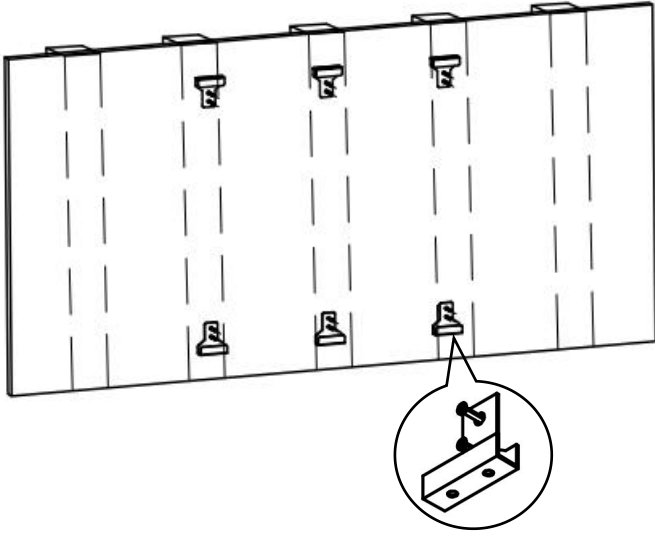

**STEP 3:** Insert the hanging plate into the mounting block and plug the limit plug as shown.

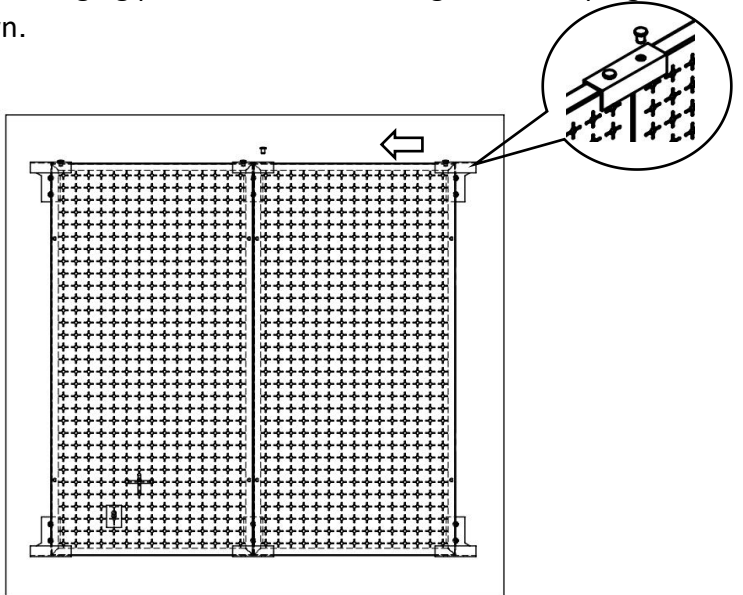



**STEP 4:** Follow the steps above to install other pegboards.

When the installation is complete, you can hang your items.

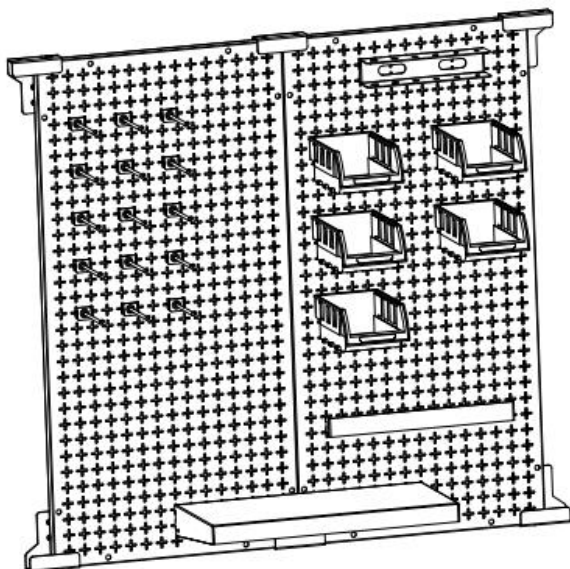

Storage box assembly:

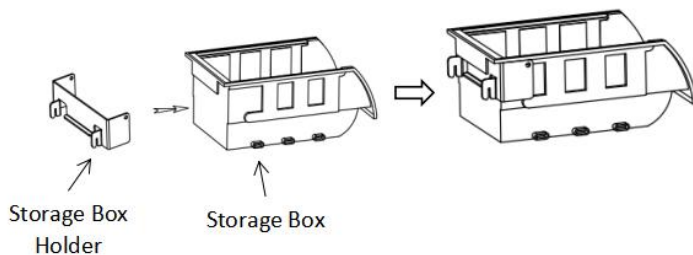

## MAINTENANCE

- Do not exceed the weight capacity.
- After use, please clean and dry the product in a dry ventilated place.

**Manufacturer:** Shanghaimuxinmuyeyouxiangongsi

**Address:** Shuangchenglu 803nong11hao1602A-1609shi, baoshanqu, shanghai 200000 CN.

**Imported to AUS:** SIHAO PTY LTD, 1 ROKEVA STREETEASTWOOD NSW 2122 Australia

**Imported to USA:** Sanven Technology Ltd., Suite 250, 9166 Anaheim Place, Rancho Cucamonga, CA 91730

EC	REP
----	-----

E-CrossStu GmbH  
Mainzer Landstr.69, 60329 Frankfurt am Main.

UK	REP
----	-----

YH CONSULTING LIMITED.  
C/O YH Consulting Limited Office 147, Centurion House,  
London Road, Staines-upon-Thames, Surrey, TW18 4AX



**VEVOR<sup>®</sup>**

**TOUGH TOOLS, HALF PRICE**

**Technical Support and E-Warranty Certificate**

**[www.vevor.com/support](http://www.vevor.com/support)**

# **VEVOR<sup>®</sup>**

**TOUGH TOOLS, HALF PRICE**

Techniczny Wsparcie i certyfikat gwarancji elektronicznej [www.vevor.com/support](http://www.vevor.com/support)

## **PŁYTA PERGLOWANA INSTRUKCJA OBSŁUGI**

We continue to be committed to provide you tools with competitive price.

"Save Half", "Half Price" or any other similar expressions used by us only represents an estimate of savings you might benefit from buying certain tools with us compared to the major top brands and does not necessarily mean to cover all categories of tools offered by us. You are kindly reminded to verify carefully when you are placing an order with us if you are actually saving half in comparison with the top major brands.

# VEVOR®

TOUGH TOOLS, HALF PRICE

## PEGBOARD

MODELE:HB641601 ,HB641602,HB9632

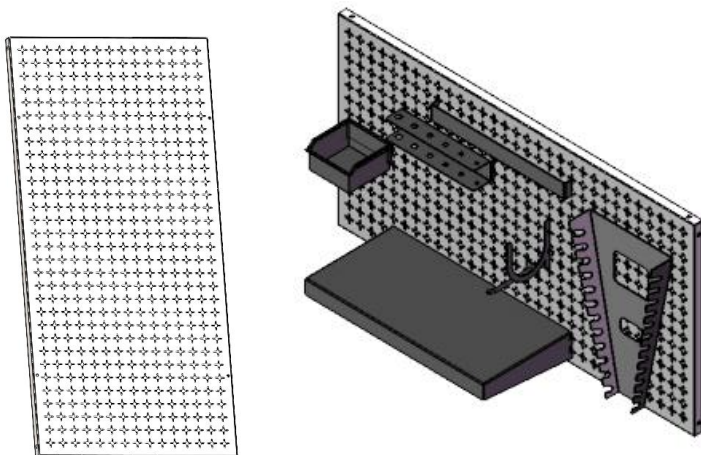

### NEED HELP? CONTACT US!

Have product questions? Need technical support? Please feel free to contact us:

**Technical Support and E-Warranty Certificate**  
[www.vevor.com/support](http://www.vevor.com/support)

This is the original instruction, please read all manual instructions carefully before operating. VEVOR reserves a clear interpretation of our user manual. The appearance of the product shall be subject to the product you received. Please forgive us that we won't inform you again if there are any technology or software updates on our product.

## SAFETY INSTRUCTIONS



### **OSTRZEŻENIE:**

1. Przeczytaj ten materiał przed użyciem tego produktu. Niedopełnienie tego obowiązku może spowodować poważne obrażenia.
2. Nie przekraczać dopuszczalnego udźwigu wideł paletowych .
3. Po użyciu należy wysuszyć przed schowaniem, aby zapobiec rdzewieniu produktu .
4. Procedury, które nie zostały szczegółowo opisane w niniejszej instrukcji, mogą być wykonywane wyłącznie przez wykwalifikowanego technika.

**Aby zapobiec poważnym obrażeniom spowodowanym awarią narzędzia, nie należy go używać, gdy jest uszkodzone :**

Tablicę perforowaną należy zamontować na ścianie litej.

Tablic perforowanych nie należy montować na zbyt cienkich ścianach drewnianych.

Nie wolno montować tablic perforowanych na zgniłych lub luźnych ścianach drewnianych.

Ciężar przedmiotów przeznaczonych do zawieszenia nie może przekraczać obciążenia tablicy perforowanej.

Przy wymianie haka należy pamiętać o dobraniu go do rozmiaru tablicy perforowanej.

Unikaj ostrych punktów, ostrzy i innych przedmiotów, które mogą zarysować produkt.



### **OSTROŻNOŚĆ:**

**Uważnie przeczytaj instrukcje i procedury w celu zapewnienia bezpiecznego działania.**

**Zapisz ten podręcznik**

## MODEL AND PARAMETERS

<b>Model SPEC.</b>	HB641601	HB641602	HB9632
Tworzywo	Stal	Stal	Stal
Maksymalna nośność (pojedyncza tablica perforowana)	165 funtów	165 funtów	165 funtów
Wymiary tablicy perforowanej (dł. x szer.)	32 " * 16 "	32 " * 16 "	32 " * 16 "
Specyfikacja otworów	1/4 cala	1/4 "	1/4 cala
Grubość blachy	1,0 mm	1,0 mm	1,0 mm
Obróbka powierzchni (tablica perforowana)	Galwanizacja + Malowanie proszkowe	Galwanizacja + Malowanie proszkowe	Galwanizacja + Malowanie proszkowe
Kolor	biały	biały	biały



## COMPONENTS

Model Parts	HB641601	HB641602	HB9632
Tablica perforowana	×2	×2	×3
Hak	/	×15	×20
Skrzynka do przechowywania	/	×5	×5
Uchwyt na pudełko do przechowywania	/	× 5	× 5
załogi S Holder	/	×1	×1
Stojak	/	×1	×1
Półka	/	×1	×2
Blokada montażowa	/	×6	×8
Ty Hak	/	/	×4
W rench H older	/	/	×1
Wtyczka ograniczająca	/	× 8	×1 2

Wtyczka rozprężna	× 8	×1 2	×1 6
Wkręt samogwintujący	× 8	×1 2	×1 6
Pozycjonowanie tektury	/	× 1	× 1
Instrukcja obsługi	×1	×1	×1

## INSTALLATION INSTRUCTION

### Przygotowanie do instalacji:

1. Dwie lub więcej osób do montażu tablicy perforowanej.
2. Przygotuj dywan lub matę, aby zabezpieczyć podłogę i rozłożyć wszystkie akcesoria.
3. Proszę przygotować rękawice, aby uniknąć zarysowań ostrymi elementami, które mogą powstać w trakcie montażu.
4. Proszę otworzyć wszystkie pudełka, aby sprawdzić czy akcesoria są kompletne i w dobrym stanie .
5. Jeśli do montażu tego produktu konieczne będzie użycie elektronarzędzi, należy wcześniej ustawić niską prędkość.
6. Podczas instalacji należy wyrównać wszystkie otwory i nie dokręcać najpierw wszystkich śrub , w przeciwnym razie może to utrudnić instalację.

### Do montażu na ścianach betonowych

**KROK 1:** Umieść deskę wiszącą w pobliżu zamontowanej ściany i zaznacz otwory cienkim gwoździem lub ołówkiem. (Uwaga: dwa otwory po lewej stronie, dwa otwory po prawej stronie)

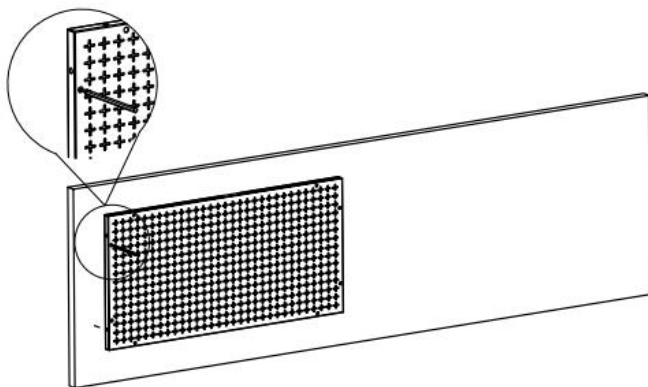

**KROK 2:** Wywierć otwory o średnicy 8 mm i głębokości 40 mm w zaznaczonych miejscach. (Uwaga: Przygotuj własne narzędzia do wiercenia .)

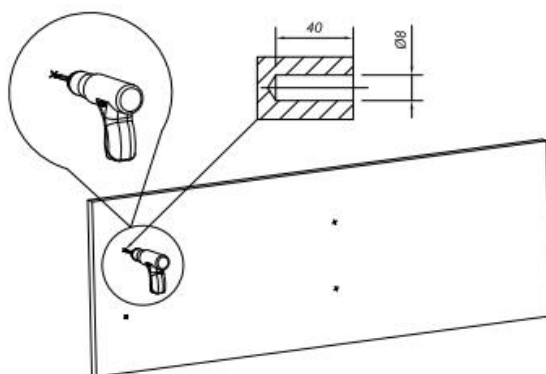

**KROK 3:** Wbij cztery kołki rozporowe do otworu.

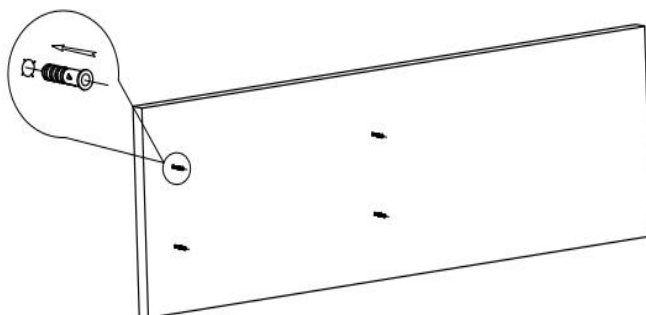

**KROK 4 :** Wkręć wkręt samogwintujący w otwór kołka rozporowego, pozostawiając 3~5 mm odsłoniętej powierzchni.

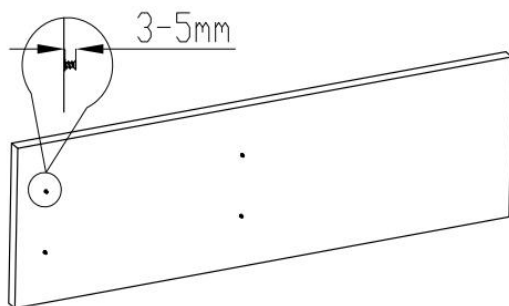

**KROK 5:** Zawieś płytę perforowaną na wkrętach samogwintujących, jak pokazano na rysunku.

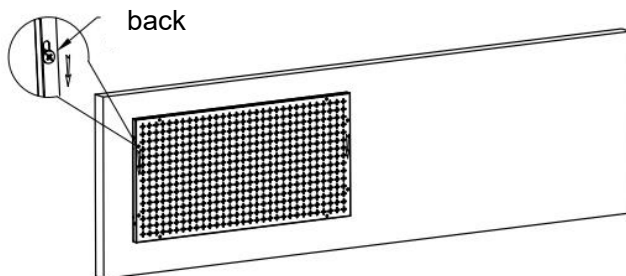

**KROK 6:** Upewnij się, że cztery wkręty samogwintujące są zawieszono w otworach montażowych płyty perforowanej i dokręć je.

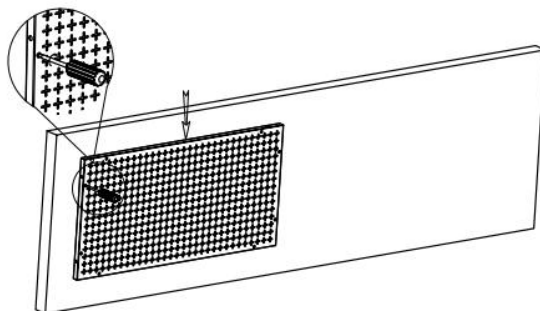

**KROK 7:** Aby zamontować pozostałe tablice perforowane, wykonaj

powyższe czynności.

(Uwaga: Tablicę perforowaną należy umieszczać poziomo i pionowo, a metoda montażu jest taka sama.)

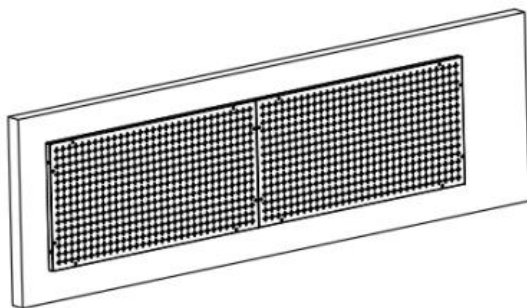

### Do montażu drewnianych słupków ściennych

**KROK 1 :** Wyrównaj krawędź płyty perforowanej ze środkową linią słupka i zaznacz otwory cienkim gwoździem lub ołówkiem. (Uwaga: dwa otwory po lewej, dwa otwory po prawej)

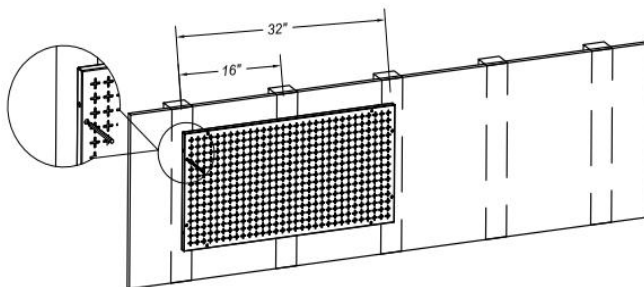

**KROK 2:** Wywierć otwory o średnicy 3 mm i głębokości 40 mm w zaznaczonych miejscach, wkręć wkręty samogwintujące w otwory, pozostawiając 3~5 mm odsłoniętej powierzchni. (Uwaga: Przygotuj własne narzędzia .)

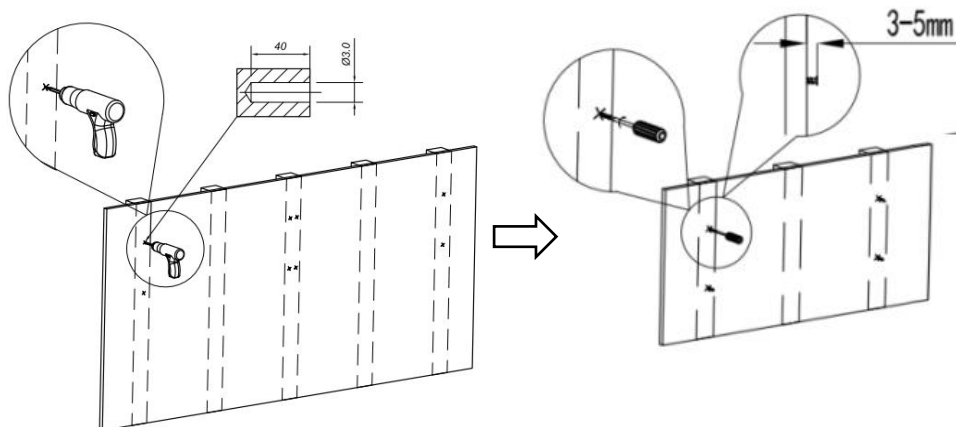

**KROK 3 : Zawieś płytę perforowaną na wkrętach samogwintujących , jak pokazano na rysunku.**

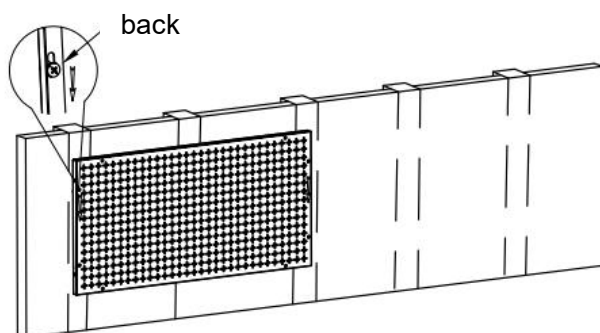

**KROK 4 : Upewnij się, że cztery wkręty samogwintujące są zawieszono w otworach montażowych płyty perforowanej, a następnie dokręć je .**

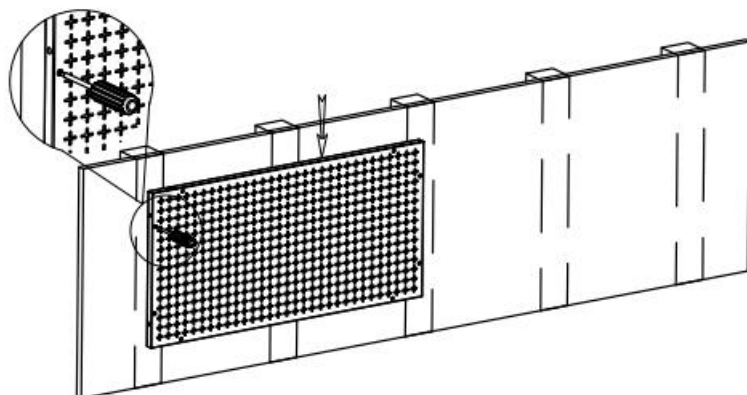

**KROK 5 :** Aby zamontować pozostałe tablice perforowane, wykonaj powyższe czynności.

(Uwaga: Tablicę perforowaną umieszcza się poziomo i pionowo, a metoda montażu jest taka sama.)

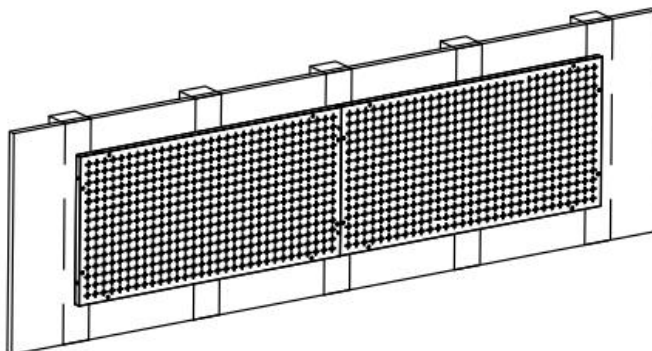

## **Dla Montaż Blokad + Montaż Ściany Betonowej**

**KROK 1:** Połóż tekturę pozycjonującą na ścianie, na której chcesz zamontować płytę, wywierć otwory zgodnie z otworami zaznaczonymi na

tekturze pozycjonującej.

Zdejmij tekturę i wywierć otwory o średnicy 8 mm i głębokości 40 mm w miejscach zaznaczonych otworów. (Uwaga: Przygotuj własne narzędzia do wiercenia .)

Wbij kołki rozporowe do otworu, dokładnie je wkręcając.

Pionowo:  $A=406\text{mm}$

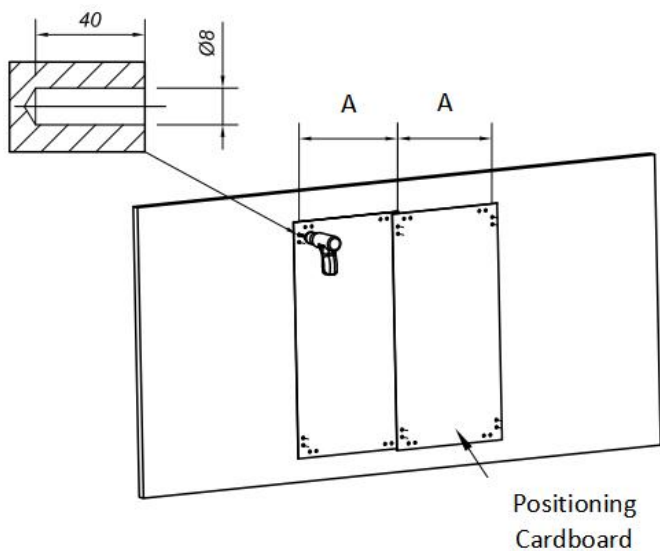

Poziomo:  $B=814\text{mm}$



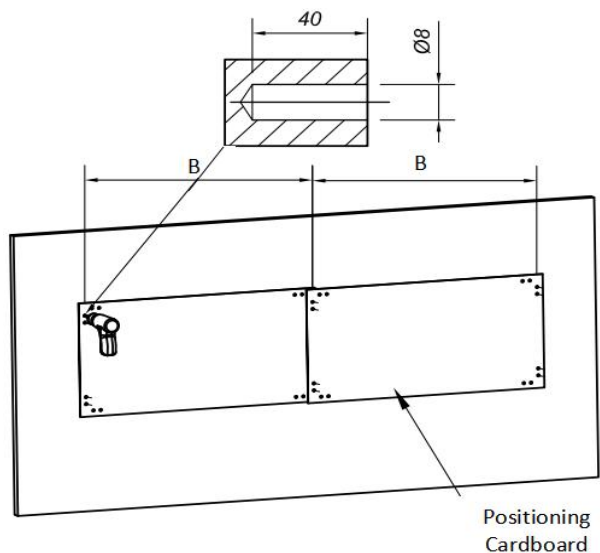

**KROK 2:** Zamocuj blok montażowy za pomocą wkrętów samogwintujących, jak pokazano ( pionowo ) .

Uwaga: Metoda montażu poziomego i pionowego jest taka sama.

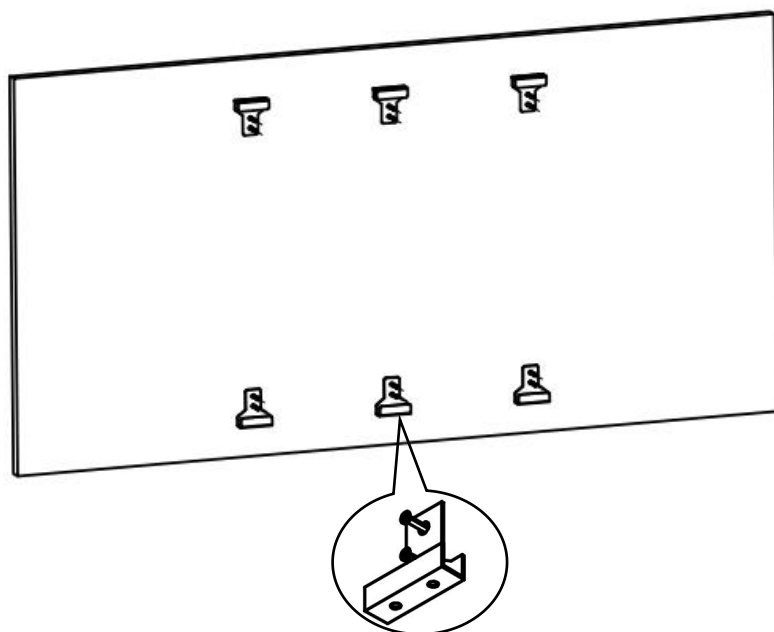

**KROK 3 :** Włóż płytkę zawieszaną do bloku montażowego i zaślep zaślepkę ograniczającą , jak pokazano .

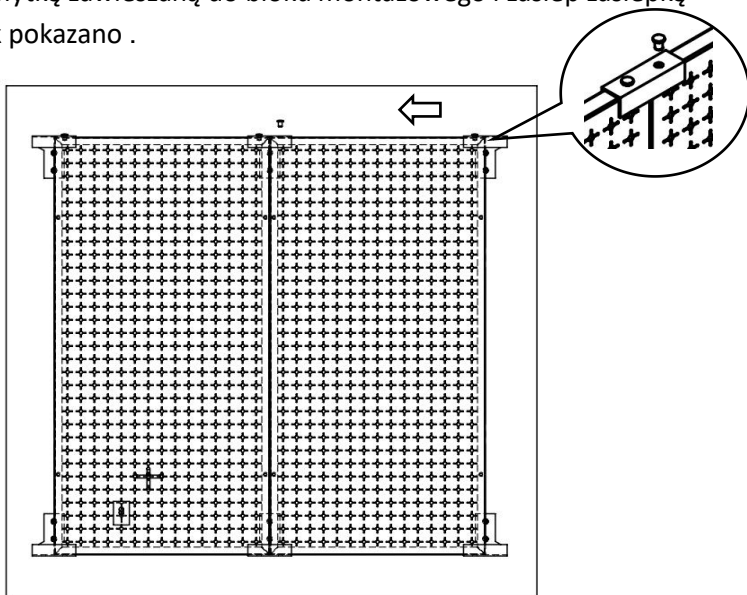

**KROK 4:** Aby zamontować pozostałe panele perforowane , wykonaj powyższe czynności .

Po zakończeniu instalacji możesz powiesić swoje przedmioty .

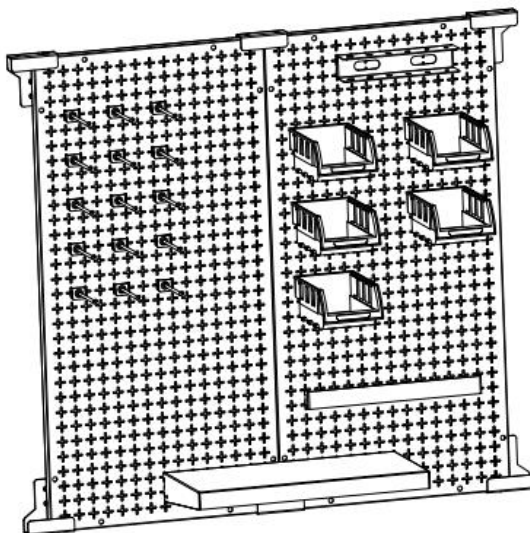

## **Dla Montaż blokady B + Montaż słupka ściennego z drewna**

**KROK 1** : Połóż tekturę pozycjonującą na ścianie, na której chcesz zamontować montaż, tak aby środek otworu w tekturze znajdował się na linii środkowej słupka.

Wywierć otwory zgodnie z otworami zaznaczonymi na tekturze pozycjonującej.

Zdejmij tekturę i wywierć otwory o średnicy 3 mm i głębokości 40 mm w miejscach zaznaczonych otworów. (Uwaga: Przygotuj własne narzędzia do wiercenia .)

Pionowo: A=406mm

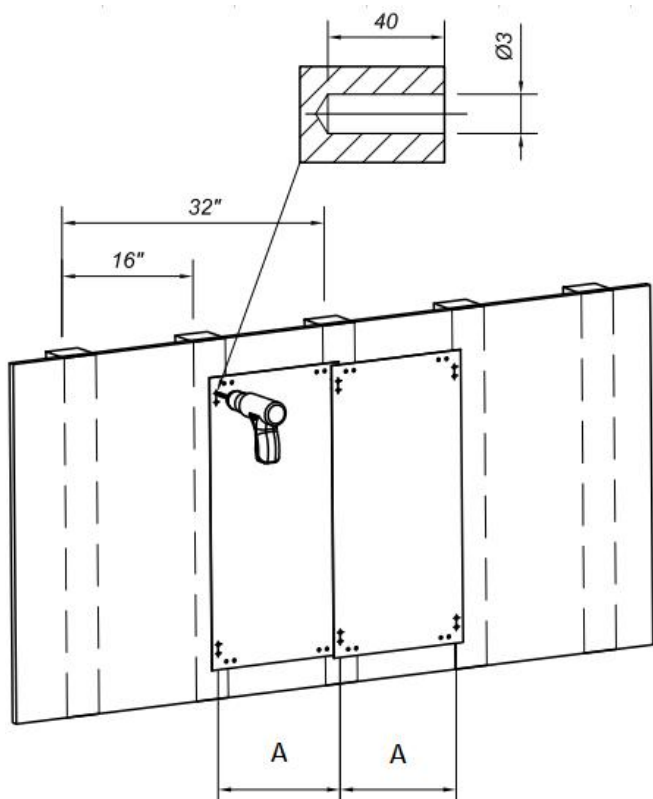

Poziomo : B=814mm

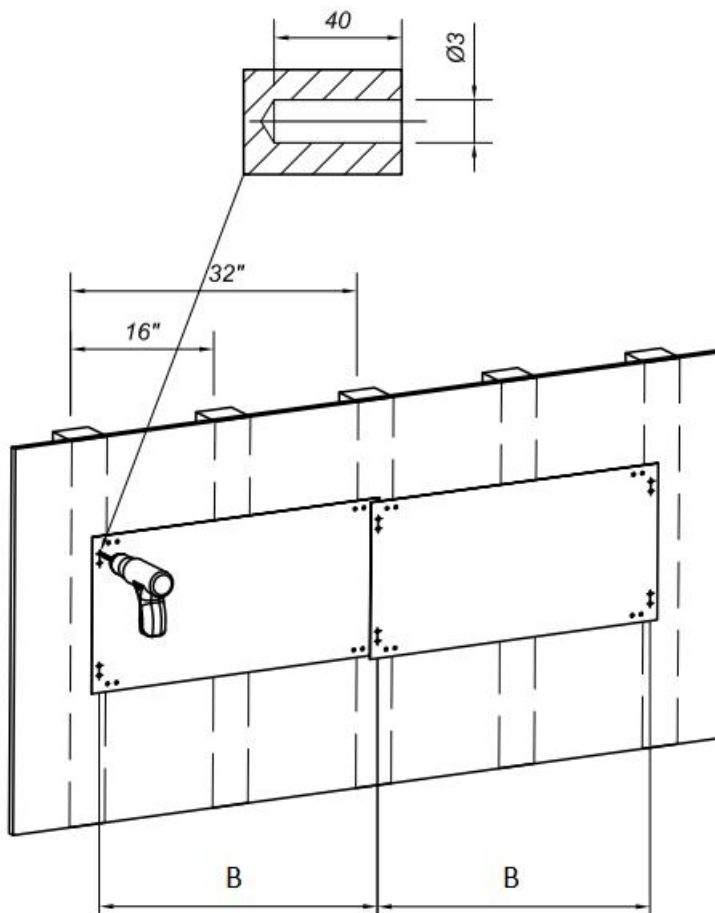

**KROK 2** : Zamocuj blok montażowy za pomocą wkrętów samogwintujących, jak pokazano ( pionowo ) .

Uwaga: Metoda montażu poziomego i pionowego jest taka sama.

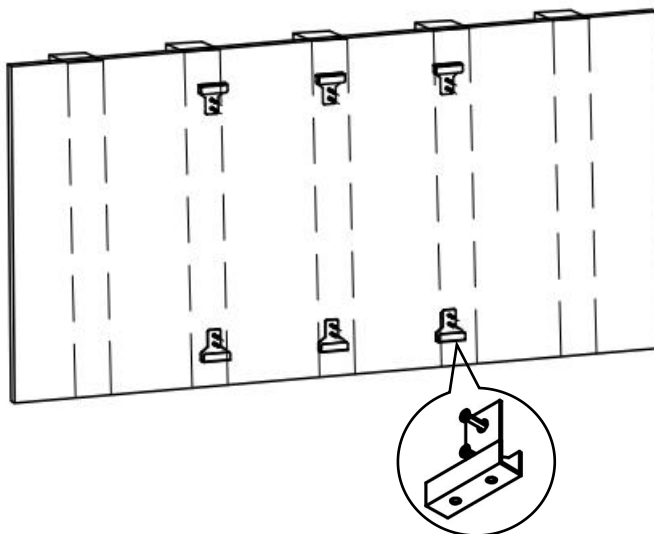

**KROK 3 :** Włóż płytkę zawieszaną do bloku montażowego i zaślep zaślepkę ograniczającą, jak pokazano .

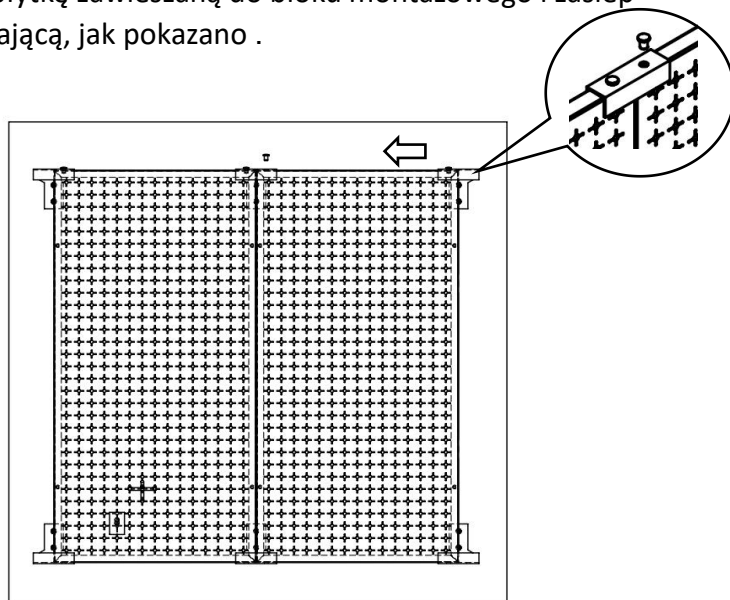

**KROK 4:** Aby zamontować pozostałe panele perforowane , wykonaj powyższe czynności .

Po zakończeniu instalacji możesz powiesić swoje przedmioty .

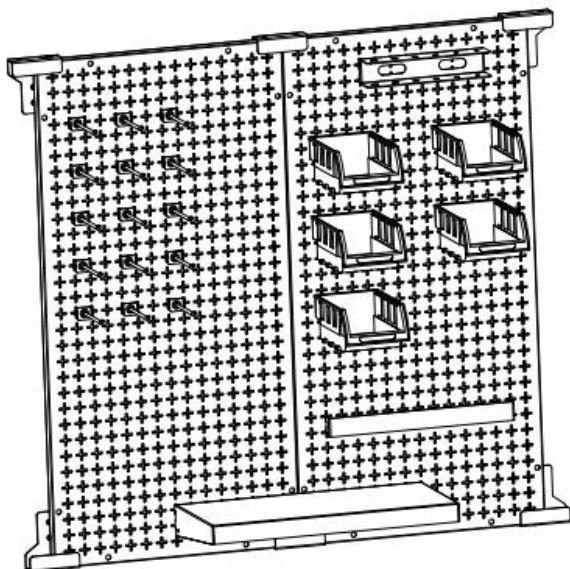

Montaż pudełka do przechowywania:

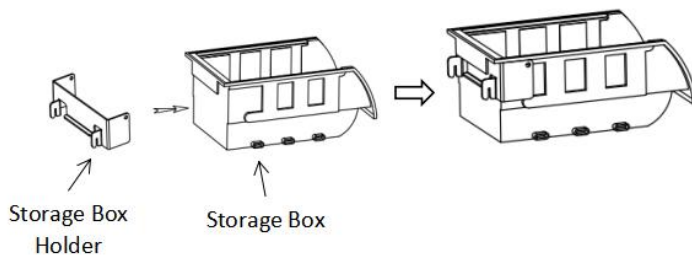

## MAINTENANCE

- Nie przekraczać wagi pojemności .
- Po użyciu należy wyczyścić i wysuszyć produkt w suchym i wentylowanym miejscu.

**Producent:** Shanghaimuxinmuyeyouxiangongsi

**Adres:** Shuangchenglu 803nong11hao1602A-1609shi, baoshanqu, szanghaj 200000 CN.

**Importowane do AUS:** SIHAO PTY LTD, 1 ROKEVA STREETEASTWOOD NSW 2122 Australia

**Importowane do USA:** Sanven Technology Ltd., Suite 250, 9166 Anaheim Place, Rancho Cucamonga, CA 91730

EC	REP
----	-----

E-CrossStu GmbH  
Mainzer Landstr.69, 60329 Frankfurt am Main.

UK	REP
----	-----

YH CONSULTING LIMITED.  
C/O YH Consulting Limited Office 147, Centurion House,  
London Road, Staines-upon-Thames, Surrey, TW18 4AX





**VEVOR**<sup>®</sup>

**TOUGH TOOLS, HALF PRICE**

**Techniczny Wsparcie i certyfikat e-gwarancji**

**[www.vevor.com/support](http://www.vevor.com/support)**

# **VEVOR<sup>®</sup>**

## **TOUGH TOOLS, HALF PRICE**

Technisch Support und E-Garantie-Zertifikat [www.vevor.com/support](http://www.vevor.com/support)

### **Stecktafel**

# **BEDIENUNGSANLEITUNG**

We continue to be committed to provide you tools with competitive price.

"Save Half", "Half Price" or any other similar expressions used by us only represents an estimate of savings you might benefit from buying certain tools with us compared to the major top brands and does not necessarily mean to cover all categories of tools offered by us. You are kindly reminded to verify carefully when you are placing an order with us if you are actually saving half in comparison with the top major brands.

# VEVOR®

TOUGH TOOLS, HALF PRICE

## PEGBOARD

MODELL: HB641601 , HB641602, HB9632

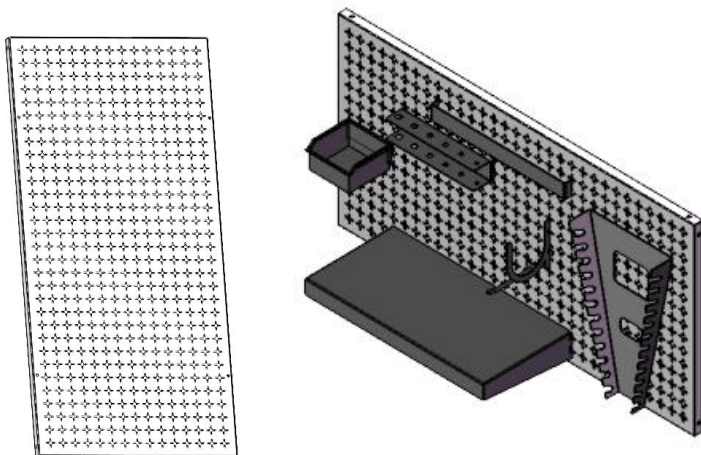

### NEED HELP? CONTACT US!

Have product questions? Need technical support? Please feel free to contact us:

**Technical Support and E-Warranty Certificate**  
[www.vevor.com/support](http://www.vevor.com/support)

This is the original instruction, please read all manual instructions carefully before operating. VEVOR reserves a clear interpretation of our user manual. The appearance of the product shall be subject to the product you received. Please forgive us that we won't inform you again if there are any technology or software updates on our product.

## SAFETY INSTRUCTIONS



### **WARNUNG:**

1. Lesen Sie dieses Material, bevor Sie dieses Produkt verwenden. Andernfalls kann es zu schweren Verletzungen kommen.
2. Die Nutzlast der Palettengabel darf nicht überschritten werden .
3. Nach dem Gebrauch vor der Lagerung trocknen lassen, um ein Rosten des Produkts zu vermeiden .
4. Verfahren, die in diesem Handbuch nicht ausdrücklich erläutert werden, dürfen nur von einem qualifizierten Techniker durchgeführt werden.

**Um schwere Verletzungen durch Werkzeugversagen zu vermeiden, verwenden Sie das Gerät nicht, wenn es beschädigt ist :**

Die Lochwand muss an einer stabilen Wand befestigt werden.

Die Lochplatten dürfen nicht an zu dünnen Holzwänden montiert werden.

Eine Montage der Lochwände an morschen oder losen Holzwänden ist nicht zulässig.

Das Gewicht der aufzuhängenden Gegenstände darf die Tragkraft der Lochwand nicht überschreiten.

Beim Austauschen der Haken muss darauf geachtet werden, dass diese passend zur Größe der Lochwand ausgewählt werden.

Vermeiden Sie scharfe Spitzen, Klingen und andere Gegenstände, die das Produkt zerkratzen könnten



### **VORSICHT:**

**Lesen Sie die Anweisungen und Verfahren für einen sicheren Betrieb sorgfältig durch.**

**Bewahren Sie dieses Handbuch auf**

## MODEL AND PARAMETERS

<b>Model SPEC.</b>	HB641601	HB641602	HB9632
Material	Stahl	Stahl	Stahl
Max. Gewichtskapazität (einzelnes Steckbrett)	165 Pfund	165 Pfund	165 Pfund
Größe der Stecktafel (L x B)	32 Zoll * 16 Zoll	32 " * 16 "	32 " * 16 "
Lochspez.	1/4 Zoll	1/4 Zoll	1/4 Zoll
Blechdicke	1,0 mm	1,0 mm	1,0 mm
Oberflächenbehandlun g (Stecktafel)	Galvanisierung+Pulver spritzen	Galvanisierung+Pulver spritzen	Galvanisierung+Pulver spritzen
Farbe	Weiß	Weiß	Weiß

## COMPONENTS

Model Parts	HB641601	HB641602	HB9632
Stecktafel	×2	×2	×3
Haken	/	×15	×20
Aufbewahrungsbox	/	×5	×5
Aufbewahrungsbox-Halter	/	× 5	× 5
S Crew Fahrerhalter	/	×1	×1
Gestell	/	×1	×1
Regal	/	×1	×2
Montageblock	/	×6	×8
U Haken	/	/	×4
Wrench H älter	/	/	×1
Begrenzungsstopfen	/	× 8	×12
Erweiterungsstecker	× 8	×12	×16
Selbstschneidende Schraube	× 8	×12	×16
Positionierungskarton	/	× 1	× 1

Benutzerhandbuch	×1	×1	×1
------------------	----	----	----

## INSTALLATION INSTRUCTION

### Vorbereitung der Installation:

1. Zum Zusammenbau der Stecktafel sind zwei oder mehr Personen erforderlich.
2. Bitte legen Sie zum Schutz Ihres Bodens einen Teppich oder eine Matte bereit, auf der Sie alle Accessoires ausbreiten können.
3. Bitte halten Sie Handschuhe bereit, um Kratzer durch scharfe Teile zu vermeiden, die bei der Installation auftreten können.
4. Bitte öffnen Sie alle Kartons um zu prüfen, ob das Zubehör vollständig und in gutem Zustand ist .
5. Wenn Sie zur Installation dieses Produkts Elektrowerkzeuge verwenden müssen, stellen Sie die Geschwindigkeit bitte vorab auf niedrige Geschwindigkeit ein.
6. bei der Installation darauf , dass alle Löcher ausgerichtet sind, und ziehen Sie nicht zuerst alle Schrauben fest , da dies sonst die Installation erschweren kann.

### Für die Installation in Betonwänden

**SCHRITT 1:** Platzieren Sie das Hängebrett in der Nähe der zu installierenden Wand und markieren Sie die Löcher mit einem feinen Nagel oder Bleistift. (Hinweis: Zwei Löcher links, zwei Löcher rechts)



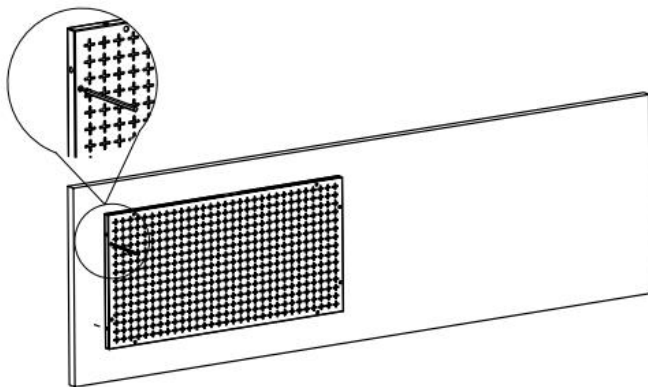

**SCHRITT 2: Bohren Sie** an den markierten Stellen Löcher mit 8 mm Durchmesser und 40 mm Tiefe . (Hinweis: Bereiten Sie Ihre eigenen Bohrwerkzeuge vor .)

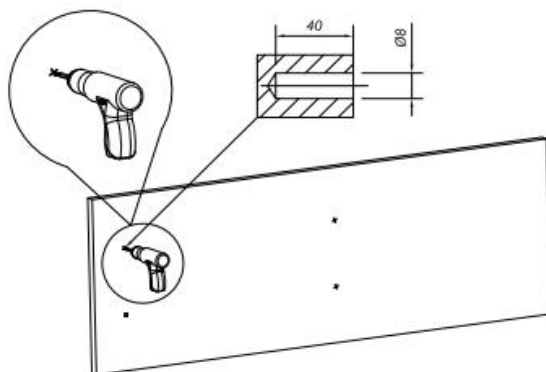

**SCHRITT 3: Nageln Sie** die vier Spreizdübel vollständig in das Loch ein.

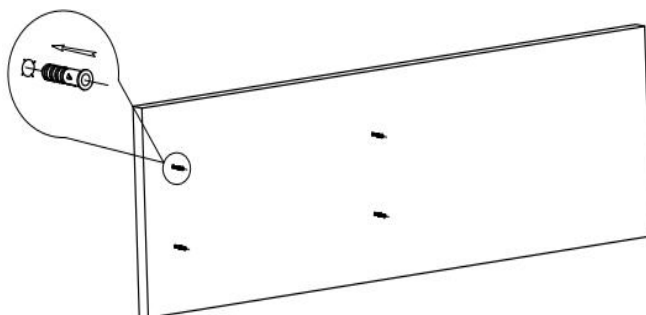

**SCHRITT 4 :** Schrauben Sie die selbstschneidende Schraube in das Loch des Spreizdübels, lassen Sie jedoch 3–5 mm frei.

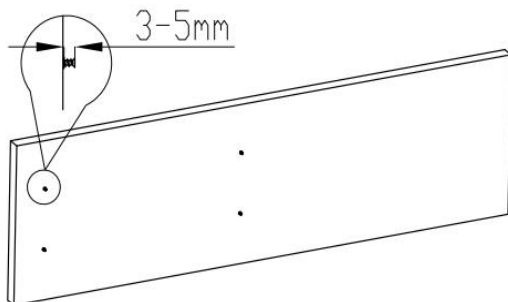

**SCHRITT 5:** Hängen Sie die Stecktafel wie in der Abbildung gezeigt an die selbstschneidenden Schrauben.

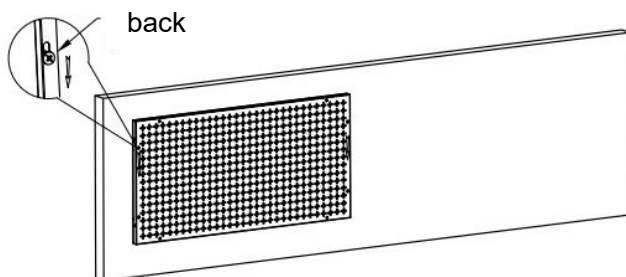

**SCHRITT 6:** Stellen Sie sicher, dass die vier selbstschneidenden Schrauben in die Montagelöcher der Stecktafel eingehängt werden und ziehen Sie die selbstschneidenden Schrauben fest.

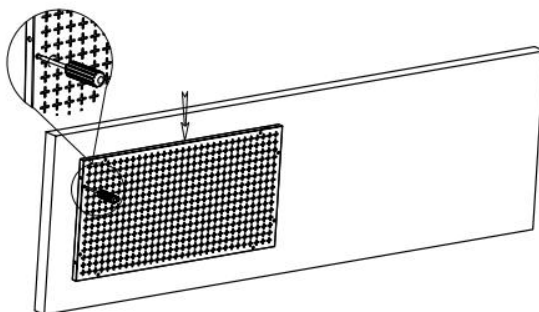

**SCHRITT 7:** Befolgen Sie die obigen Schritte, um andere Stecktafeln zu installieren.

(Hinweis: Die Stecktafel wird horizontal und vertikal angebracht und die Installationsmethode ist dieselbe.)

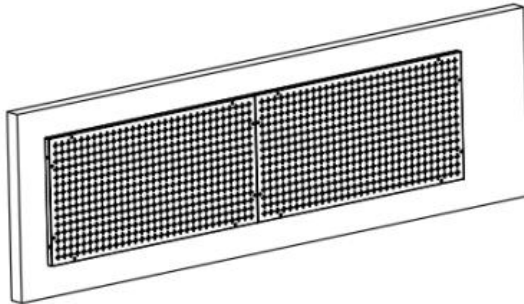

### Für die Montage von Holzwandpfosten

**SCHRITT 1 :** Richten Sie die Kante der Stecktafel an der Mittellinie des Pfostens aus und markieren Sie die Löcher mit einem feinen Nagel oder Bleistift. (Hinweis: Zwei Löcher auf der linken Seite, zwei Löcher auf der rechten Seite)

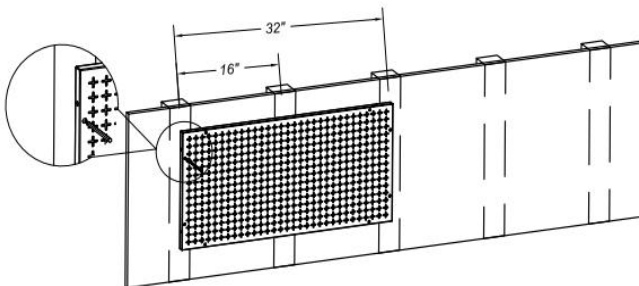

**SCHRITT 2:** Bohren Sie an den markierten Stellen Löcher mit 3 mm Durchmesser und 40 mm Tiefe. Schrauben Sie die selbstschneidende Schraube in die Löcher, lassen Sie jedoch 3–5 mm frei. (Hinweis: Legen Sie Ihr eigenes Werkzeug bereit .)

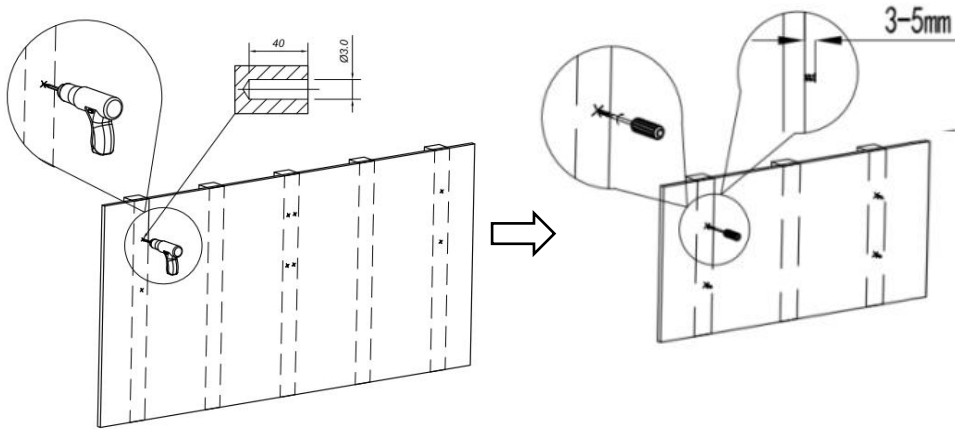

**SCHRITT 3 : Hängen Sie die Stecktafel wie in der Abbildung gezeigt an die selbstschneidenden Schrauben .**

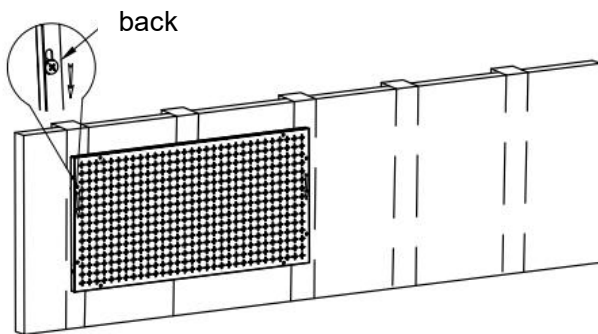

**SCHRITT 4 :** Stellen Sie sicher, dass die vier selbstschneidenden Schrauben in die Montagelöcher der Stecktafel eingehängt werden, und ziehen Sie die selbstschneidenden Schrauben fest .

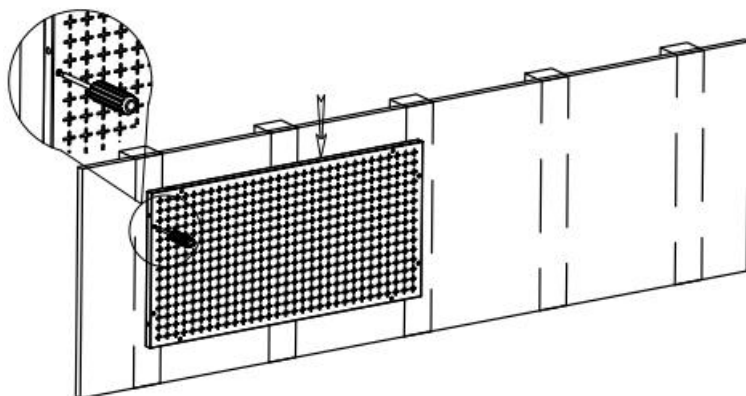

**SCHRITT 5** : Befolgen Sie die obigen Schritte, um andere Stecktafeln zu installieren.

(Hinweis: Die Stecktafel wird horizontal und vertikal platziert und die Installationsmethode ist dieselbe.)

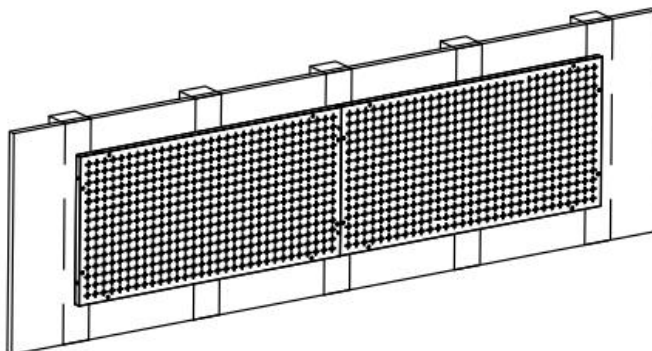

### **Für Montageblock + Betonwandmontage**

**SCHRITT 1**: Legen Sie den Positionierungskarton an die zu montierende Wand und bohren Sie die Markierungslöcher entsprechend den auf dem

Positionierungskarton markierten Löchern.

Nehmen Sie den Karton weg und bohren Sie an den Markierungslochern Löcher mit 8 mm Durchmesser und 40 mm Tiefe. (Hinweis: Legen Sie Ihre eigenen Bohrwerkzeuge bereit .)

Nageln Sie die Spreizdübel vollständig in das Loch ein.

Vertikal:  $A = 406 \text{ mm}$

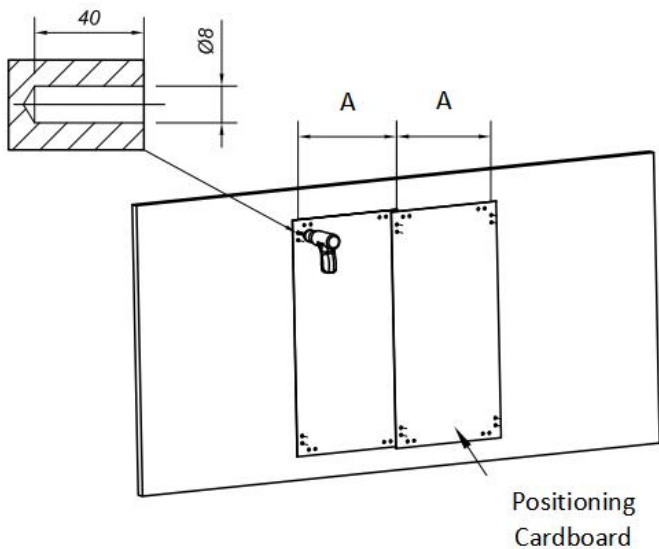

Horizontal:  $B=814\text{mm}$

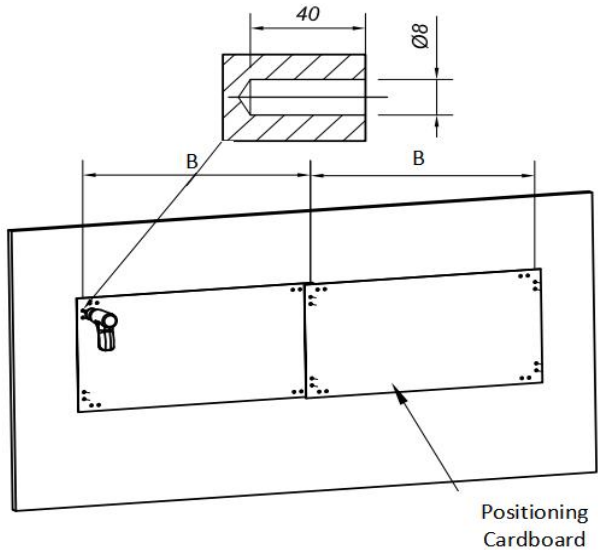

**SCHRITT 2:** Befestigen Sie den Montageblock wie gezeigt ( vertikal ) mit selbstschneidenden Schrauben .

Hinweis: Die horizontale und vertikale Installationsmethode ist dieselbe.

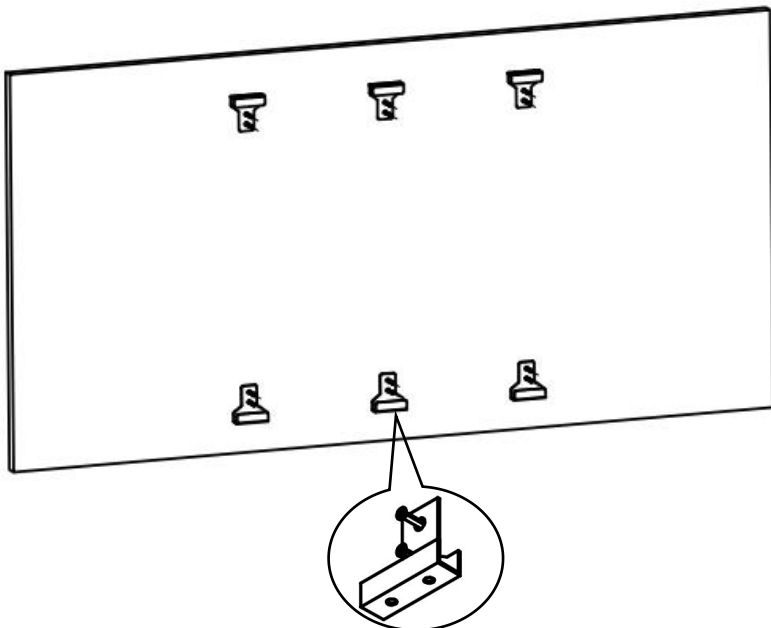

**SCHRITT 3 :** Die Aufhängeplatte in den Montageblock einsetzen und den Begrenzungsstopfen wie dargestellt einstecken .

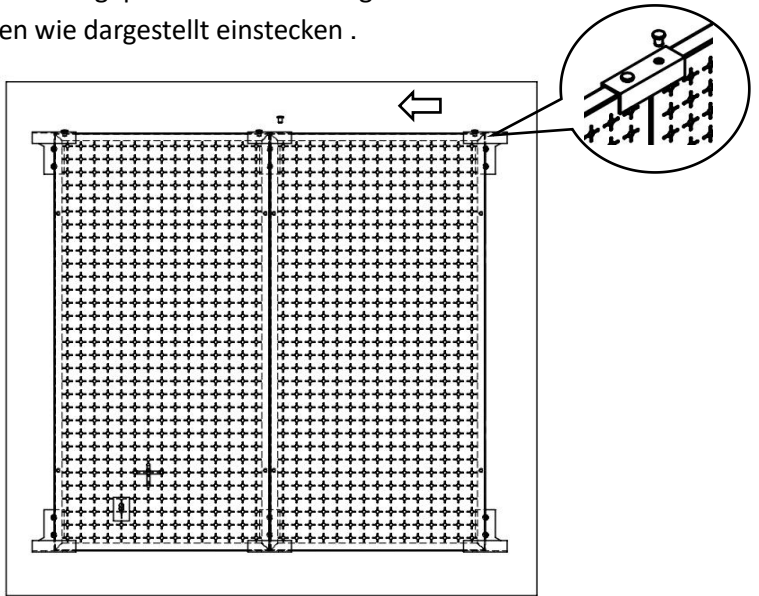

**SCHRITT 4:** Befolgen Sie die obigen Schritte, um weitere Stecktafeln zu installieren .

Wenn die Installation abgeschlossen ist, können Sie Ihre Artikel aufhängen .

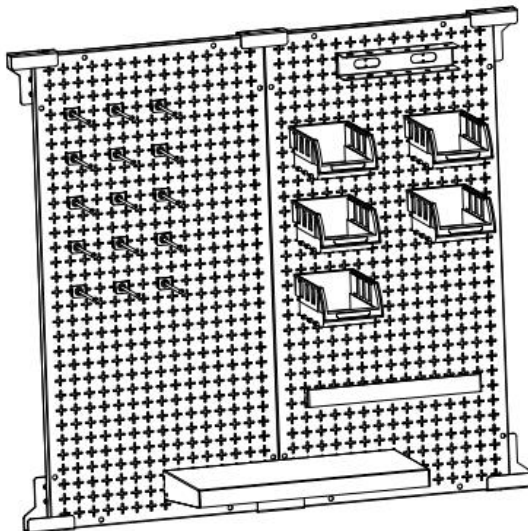



## **Für Montageblock + Holzwandpfostenmontage**

**SCHRITT 1** : Legen Sie den Positionierungskarton an die zu installierende Wand und achten Sie darauf, dass sich die Mitte des Lochs im Karton auf der Mittellinie des Pfostens befindet.

Bohren Sie die Markierungslöcher entsprechend den auf dem Positionierkarton markierten Löchern.

Nehmen Sie den Karton weg und bohren Sie an den Markierungslöchern Löcher mit 3 mm Durchmesser und 40 mm Tiefe. (Hinweis: Legen Sie Ihre eigenen Bohrwerkzeuge bereit .)

Vertikal: A = 406 mm

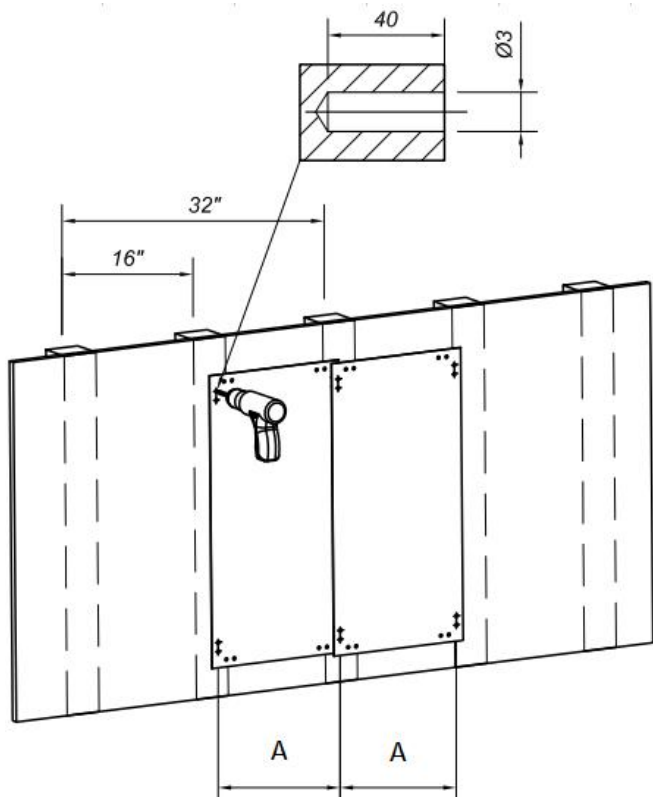

Horizontal : B=814mm

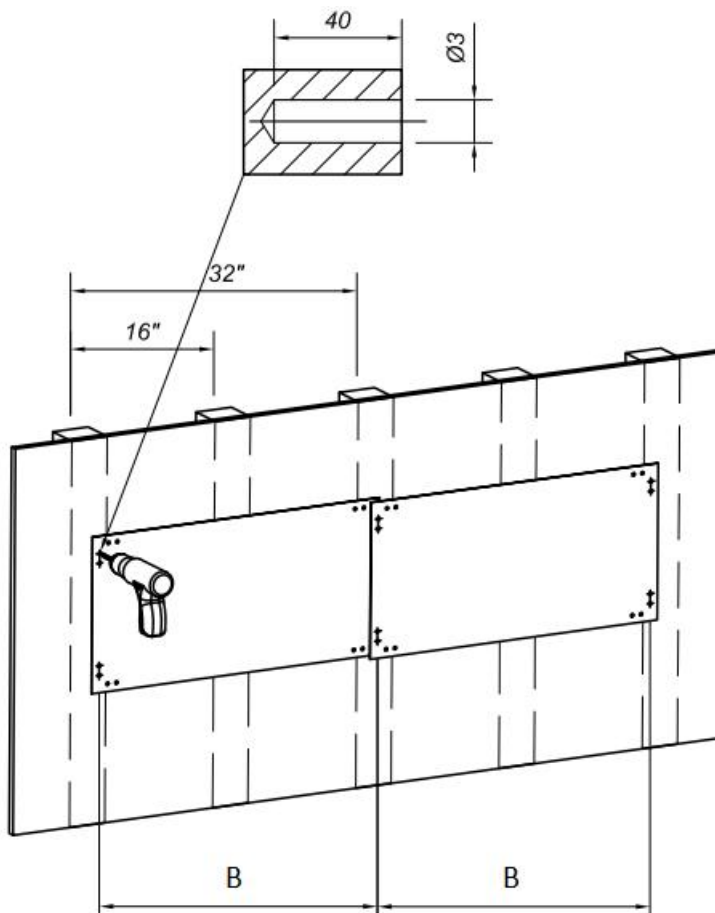

**SCHRITT 2** : Befestigen Sie den Montageblock wie gezeigt ( vertikal ) mit selbstschneidenden Schrauben .

Hinweis: Die horizontale und vertikale Installationsmethode ist dieselbe.

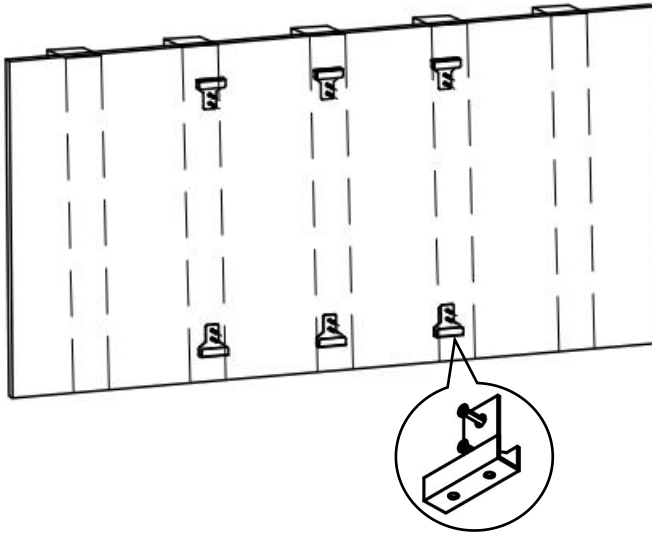

**SCHRITT 3 :** Die Aufhängeplatte in den Montageblock einsetzen und den Begrenzungsstopfen wie dargestellt einstecken .

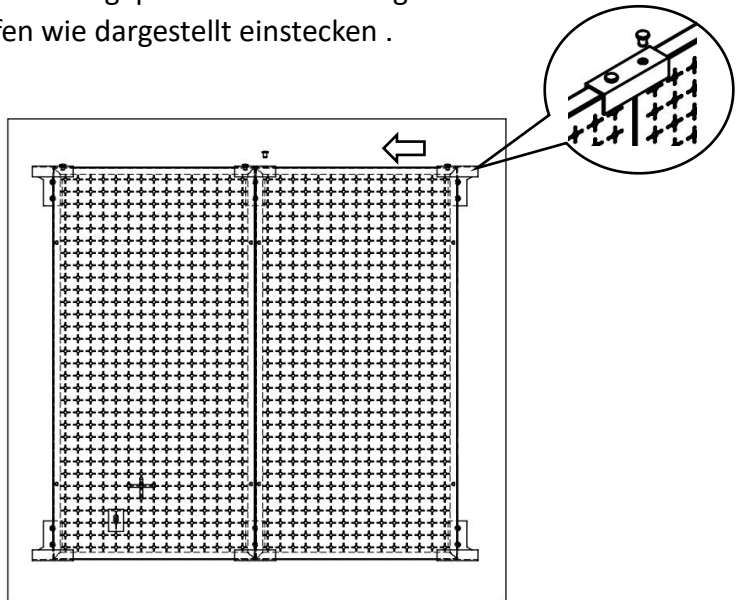

**SCHRITT 4:** Befolgen Sie die obigen Schritte, um weitere Stecktafeln zu installieren .

Wenn die Installation abgeschlossen ist, können Sie Ihre Artikel aufhängen .

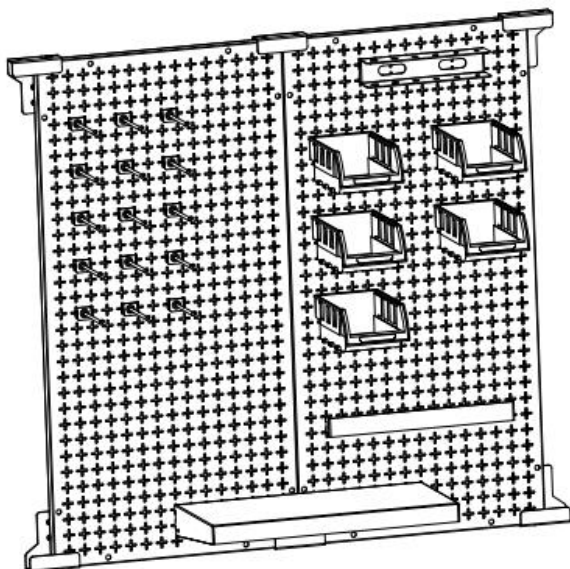

Montage der Aufbewahrungsbox:

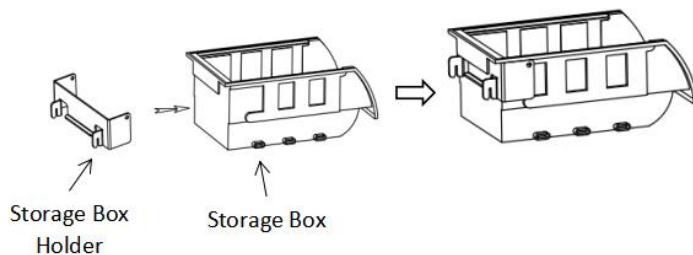

## MAINTENANCE

- Das Gewicht nicht überschreiten Kapazität .
- Bitte reinigen und trocknen Sie das Produkt nach dem Gebrauch an einem trockenen, belüfteten Ort.

**Hersteller:** Shanghaimuxinmuyeyouxiangongsi

**Adresse:** Shuangchenglu 803nong11hao1602A-1609shi, baoshanqu, Shanghai 200000 CN.

**Nach AUS importiert:** SIHAO PTY LTD, 1 ROKEVA STREETEASTWOOD NSW 2122 Australien

**Importiert in die USA:** Sanven Technology Ltd., Suite 250, 9166 Anaheim Place, Rancho Cucamonga, CA 91730

<b>EC</b>	<b>REP</b>
-----------	------------

E-CrossStu GmbH  
Mainzer Landstr.69, 60329 Frankfurt am Main.

<b>UK</b>	<b>REP</b>
-----------	------------

YH CONSULTING LIMITED.  
C/O YH Consulting Limited Office 147, Centurion House,  
London Road, Staines-upon-Thames, Surrey, TW18 4AX



**VEVOR**<sup>®</sup>

**TOUGH TOOLS, HALF PRICE**

**Technisch Support und E-Garantie-Zertifikat**

**[www.vevor.com/support](http://www.vevor.com/support)**



# **VEVOR<sup>®</sup>**

## **TOUGH TOOLS, HALF PRICE**

Technique Certificat d'assistance et de garantie électronique  
[www.vevor.com/support](http://www.vevor.com/support)

## **PANNEAU PERFORÉ**

## **MANUEL D'UTILISATION**

We continue to be committed to provide you tools with competitive price.

"Save Half", "Half Price" or any other similar expressions used by us only represents an estimate of savings you might benefit from buying certain tools with us compared to the major top brands and does not necessarily mean to cover all categories of tools offered by us. You are kindly reminded to verify carefully when you are placing an order with us if you are actually saving half in comparison with the top major brands.

# VEVOR®

TOUGH TOOLS, HALF PRICE

## PEGBOARD

MODÈLE : HB641601 , HB641602, HB9632

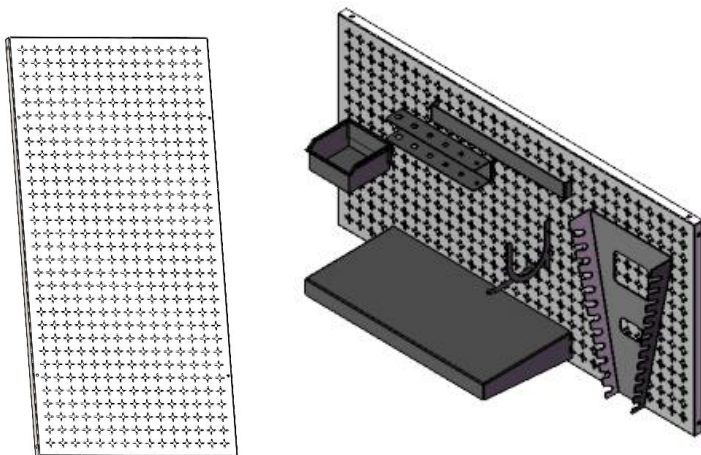

### NEED HELP? CONTACT US!

Have product questions? Need technical support? Please feel free to contact us:

**Technical Support and E-Warranty Certificate**  
[www.vevor.com/support](http://www.vevor.com/support)

This is the original instruction, please read all manual instructions carefully before operating. VEVOR reserves a clear interpretation of our user manual. The appearance of the product shall be subject to the product you received. Please forgive us that we won't inform you again if there are any technology or software updates on our product.

## SAFETY INSTRUCTIONS



### AVERTISSEMENT:

1. Lisez attentivement ce document avant d'utiliser ce produit. Le non-respect de ces instructions peut entraîner des blessures graves.
2. Ne pas dépasser la capacité de travail de la fourche à palette .
3. Après utilisation, veuillez sécher avant de ranger le produit pour éviter la rouille .
4. Les procédures non spécifiquement expliquées dans ce manuel doivent être effectuées uniquement par un technicien qualifié.

**Pour éviter des blessures graves dues à une défaillance de l'outil, ne l'utilisez pas s'il est endommagé :**

Le panneau perforé doit être monté sur un mur solide.

Les panneaux perforés ne doivent pas être installés sur des murs en bois trop fins.

Les panneaux perforés ne doivent pas être installés sur des murs en bois pourris ou détachés.

Le poids des objets à accrocher ne doit pas dépasser la charge du panneau perforé.

Lors du remplacement du crochet, celui-ci doit être sélectionné pour correspondre à la taille du panneau perforé.

Évitez les objets pointus, les lames et autres objets tranchants qui pourraient rayer le produit



### PRUDENCE:

**Lisez attentivement les instructions et les procédures pour des opérations en toute sécurité.**

**Sauvegarder ce manuel**

## MODEL AND PARAMETERS

<b>Model SPEC.</b>	HB641601	HB641602	HB9632
Matériel	Acier	Acier	Acier
Capacité de poids maximale (panneau perforé unique)	165 livres	165 livres	165 livres
Taille du panneau perforé (L x l)	32 " * 16 "	32 " *16 "	32 " *16 "
Spécification du trou	1/4 "	1/4 "	1/4 "
Épaisseur de la tôle	1,0 mm	1,0 mm	1,0 mm
Traitement de surface (panneau perforé)	Galvanisation + pulvérisation de poudre	Galvanisation + pulvérisation de poudre	Galvanisation + pulvérisation de poudre
Couleur	blanc	blanc	blanc

## COMPONENTS

Model Parts	HB641601	HB641602	HB9632
Panneau perforé	×2	×2	×3
Crochet	/	×15	×20
Boîte de rangement	/	×5	×5
Support de boîte de rangement	/	× 5	× 5
d'équipage S Holder	/	×1	×1
Étagère	/	×1	×1
Étagère	/	×1	×2
Bloc de montage	/	×6	×8
Tu Crochet	/	/	×4
Clé H plus âgée	/	/	×1
Bouchon limiteur	/	× 8	×1 2
Fiche d'extension	× 8	×1 2	×1 6
Vis autotaraudeuse	× 8	×1 2	×1 6

Positionnement du carton	/	x 1	x 1
Manuel d' utilisation	x1	x1	x1

## INSTALLATION INSTRUCTION

### Préparation de l'installation :

1. Deux personnes ou plus pour assembler le panneau perforé.
2. Veuillez préparer un tapis ou un paillason pour protéger votre sol, vous devez étaler tous les accessoires.
3. Veuillez préparer des gants pour éviter d'être rayé par des pièces tranchantes qui pourraient survenir lors de l'installation.
4. Veuillez ouvrir toutes les boîtes pour vérifier si les accessoires sont complets et en bon état .
5. Si vous devez utiliser des outils électriques pour installer ce produit, veuillez régler la vitesse sur basse à l'avance.
6. Lors de l'installation , veuillez aligner tous les trous et ne serrez pas toutes les vis au préalable , sinon cela pourrait rendre l'installation difficile.

### Pour l'installation de murs en béton

**ÉTAPE 1** : Placez la planche suspendue près du mur installé et marquez les trous avec un clou fin ou un crayon. (Remarque : deux trous à gauche, deux trous à droite)

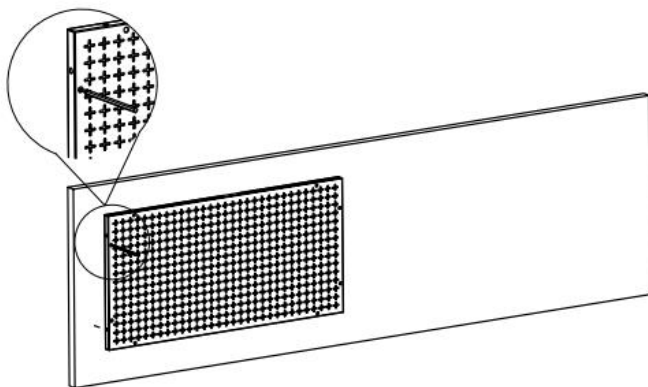

**ÉTAPE 2 :** Percez des trous de 8 mm de diamètre et de 40 mm de profondeur aux endroits marqués. (Remarque : préparez vos propres outils de perçage .)

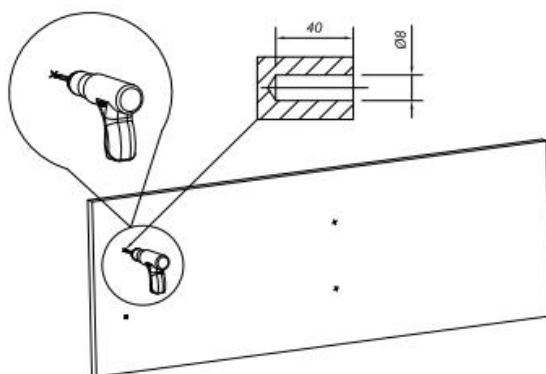

**ÉTAPE 3 :** Clouez complètement les quatre chevilles d' expansion dans le trou.

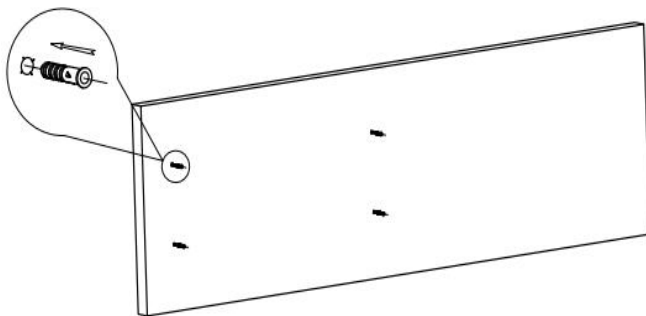

**ÉTAPE 4 :** Vissez la vis autotaraudeuse dans le trou du bouchon d'expansion, en laissant 3 à 5 mm exposés.

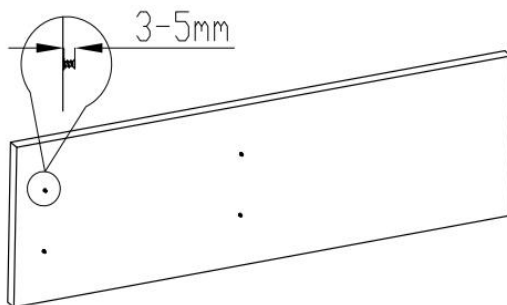

**ÉTAPE 5 :** Accrochez le panneau perforé sur les vis autotaraudeuses, comme indiqué sur l'image.

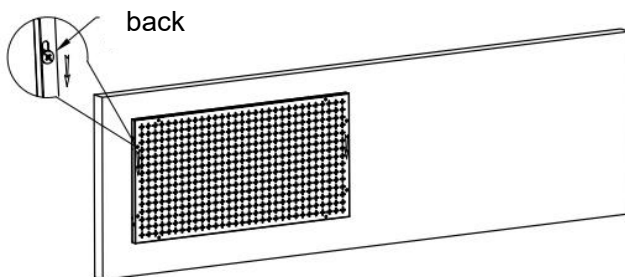

**ÉTAPE 6 :** Assurez-vous que les quatre vis autotaraudeuses sont accrochées dans les trous de montage du panneau perforé et serrez les vis autotaraudeuses.



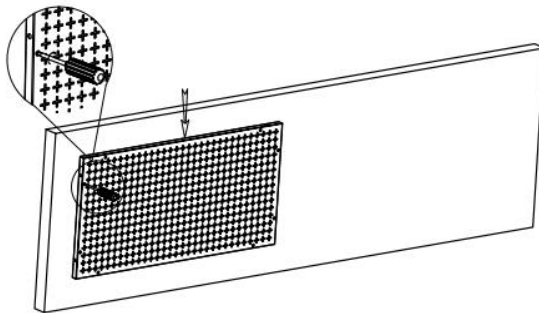

**ÉTAPE 7 :** Suivez les étapes ci-dessus pour installer d' autres panneaux perforés.

(Remarque : le panneau perforé est placé horizontalement et verticalement, et la méthode d'installation est la même.)

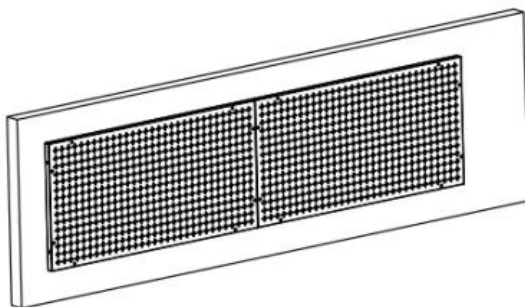

### **Pour l'installation de poteaux muraux en bois**

**ÉTAPE 1 :** Alignez le bord du panneau perforé avec la ligne centrale du poteau et marquez les trous avec un clou fin ou un crayon. (Remarque : deux trous à gauche, deux trous à droite)

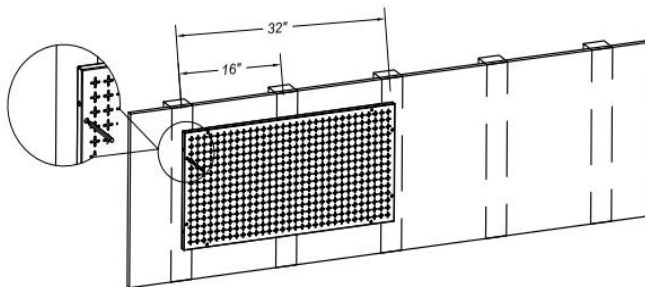

**ÉTAPE 2 : Percez des trous de 3 mm de diamètre et de 40 mm de profondeur aux endroits marqués, vissez la vis autotaraudeuse dans les trous, en laissant 3 à 5 mm exposés. (Remarque : préparez vos propres outils .)**

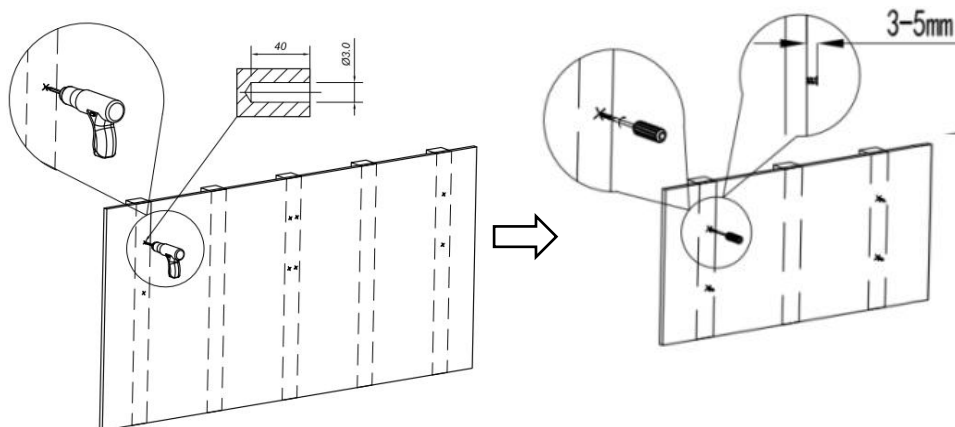

**ÉTAPE 3 : Accrochez le panneau perforé sur les vis autotaraudeuses , comme indiqué sur l'image.**

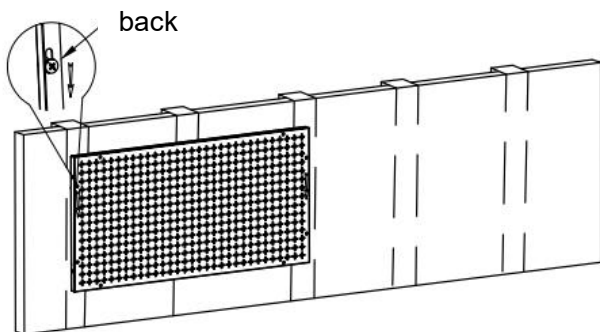

**ÉTAPE 4 :** Assurez-vous que les quatre vis autotaraudeuses sont accrochées dans les trous de montage du panneau perforé et serrez les vis autotaraudeuses .

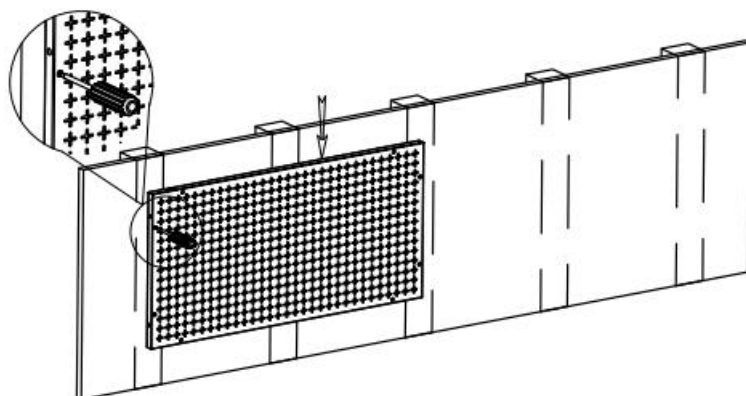

**ÉTAPE 5 :** Suivez les étapes ci-dessus pour installer d'autres panneaux perforés.

(Remarque : le panneau perforé est placé horizontalement et verticalement, et la méthode d'installation est la même.)

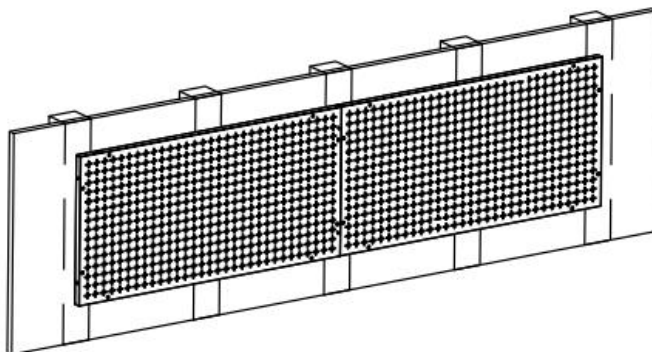

## **Pour Bloc de montage + installation sur mur en béton**

**ÉTAPE 1** : Posez le carton de positionnement sur le mur à installer, percez les trous de marquage en fonction des trous marqués sur le carton de positionnement.

Retirez le carton et percez des trous de 8 mm de diamètre et de 40 mm de profondeur au niveau des trous de marquage. (Remarque : préparez vos propres outils de perçage .)

Clouez complètement les chevilles d'expansion dans le trou.

Verticale : A = 406 mm

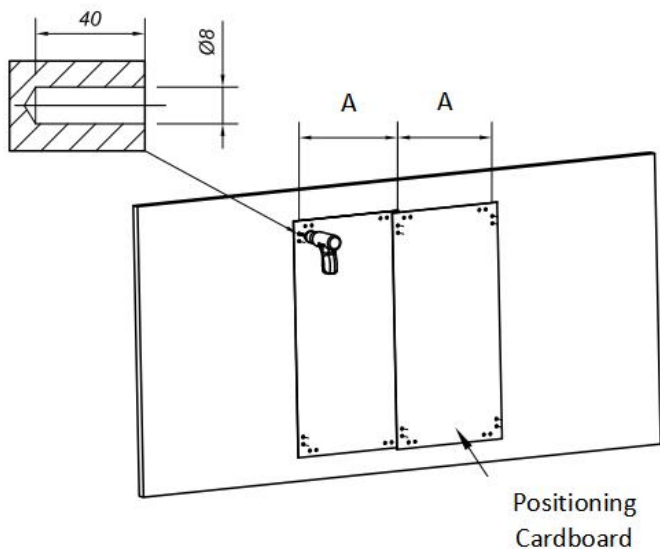

Horizontale : B = 814 mm

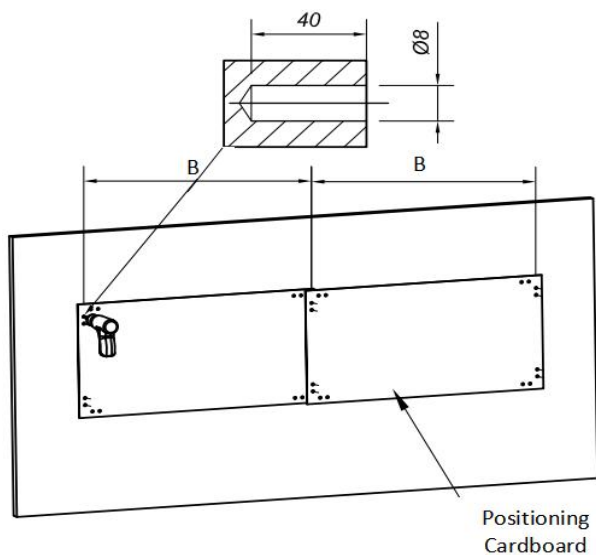

**ÉTAPE 2** : Fixez le bloc de montage avec des vis autotaraudeuses comme indiqué ( vertical ) .

Remarque : la méthode d'installation horizontale et verticale est la même.

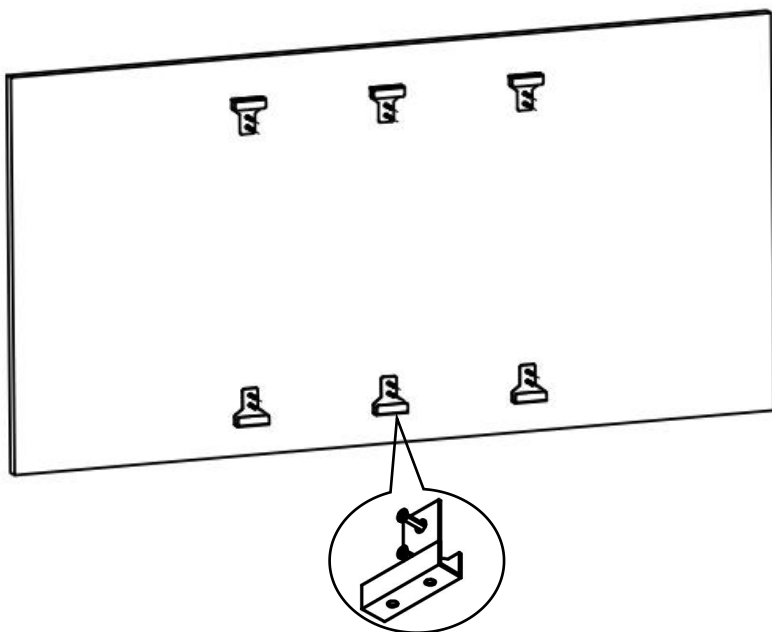

**ÉTAPE 3 :** Insérez la plaque de suspension dans le bloc de montage et branchez le bouchon de limite comme indiqué .

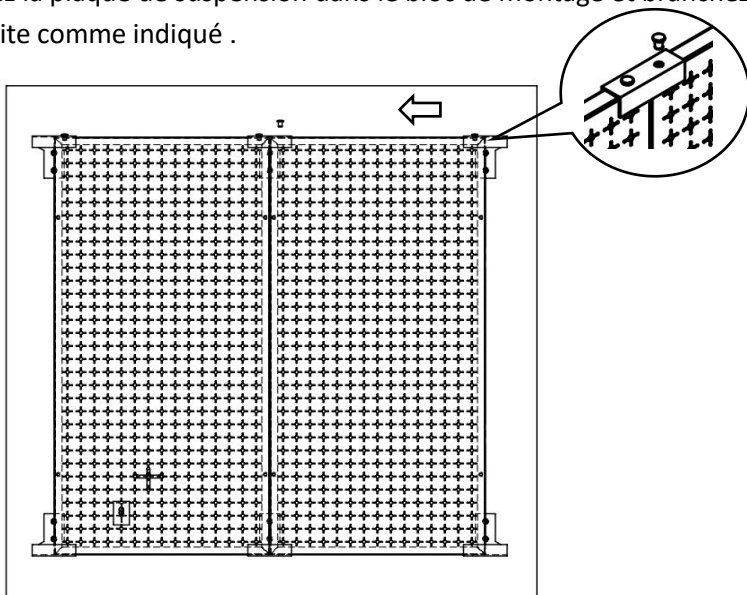

**ÉTAPE 4 :** Suivez les étapes ci-dessus pour installer d'autres panneaux perforés .

Une fois l'installation terminée, vous pouvez accrocher vos objets .

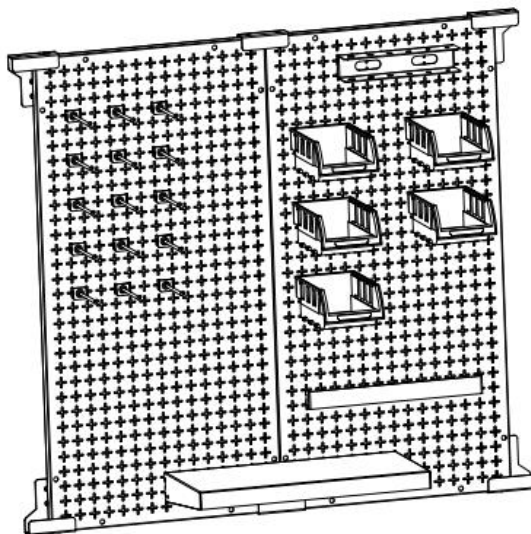

### **Pour Bloc de montage + installation de poteau mural en bois**

**ÉTAPE 1** : Posez le carton de positionnement sur le mur à installer, et le centre du trou sur le carton est situé sur la ligne médiane du poteau.

Percez les trous de marquage en fonction des trous marqués sur le carton de positionnement.

Retirez le carton et percez des trous de 3 mm de diamètre et de 40 mm de profondeur au niveau des trous de marquage. (Remarque : préparez vos propres outils de perçage .)

Verticale : A = 406 mm

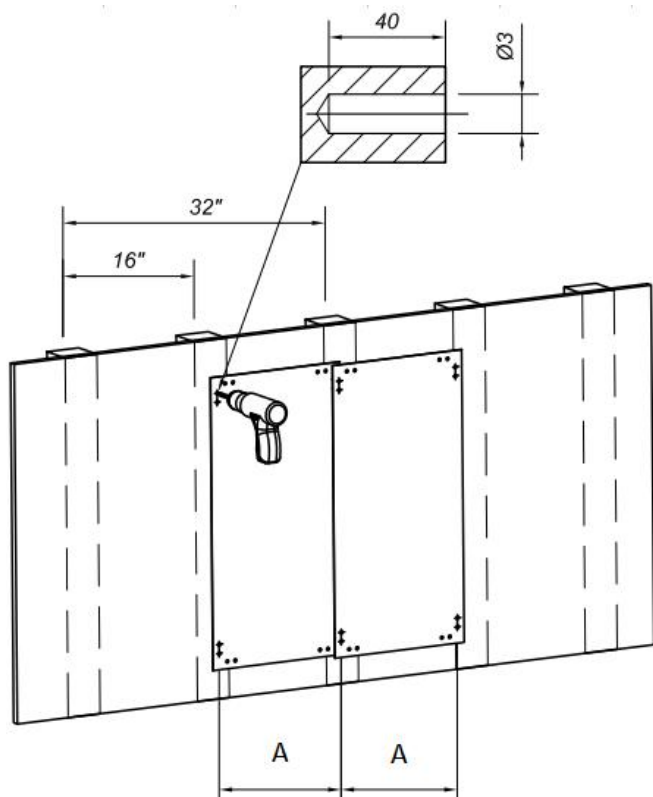

Horizontale : B=814mm



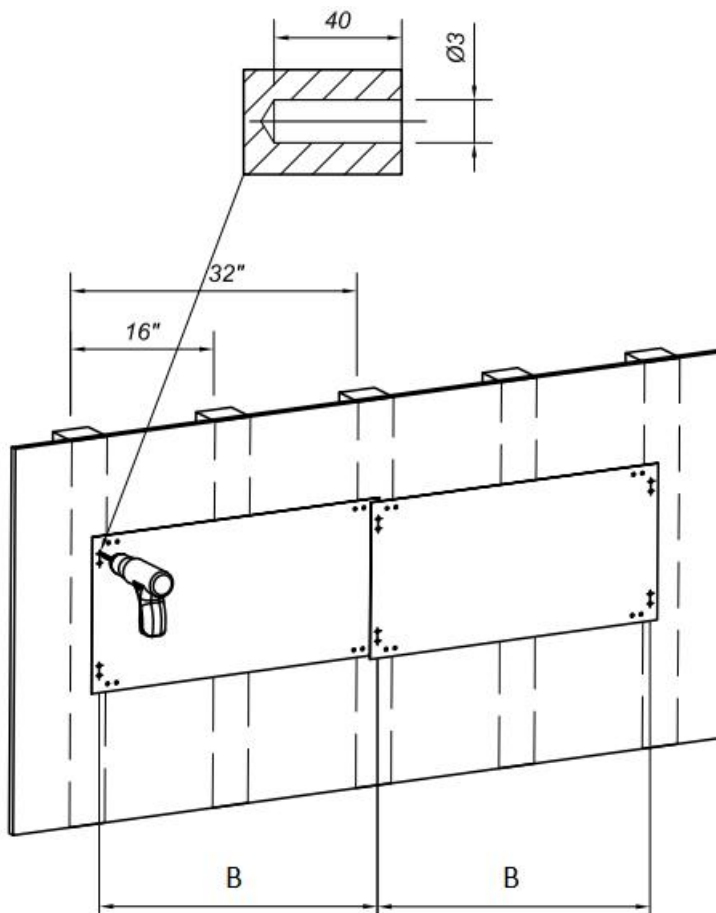

**ÉTAPE 2** : Fixez le bloc de montage avec des vis autotaraudeuses comme indiqué ( vertical ) .

Remarque : la méthode d'installation horizontale et verticale est la même.

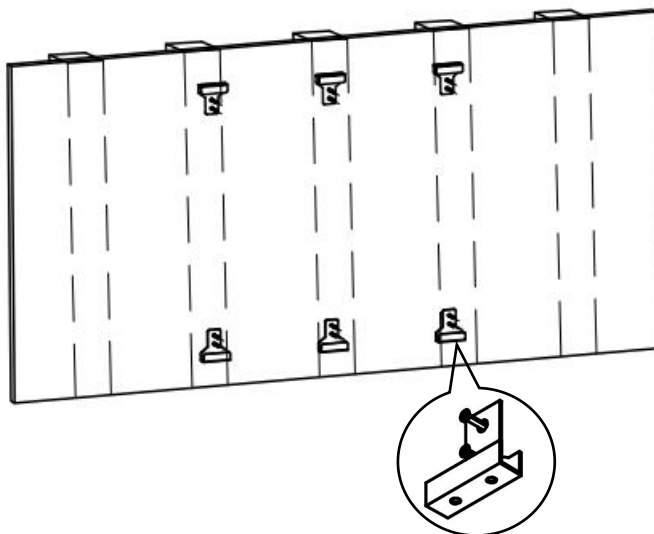

**ÉTAPE 3** : Insérez la plaque de suspension dans le bloc de montage et branchez le bouchon de limite comme indiqué .

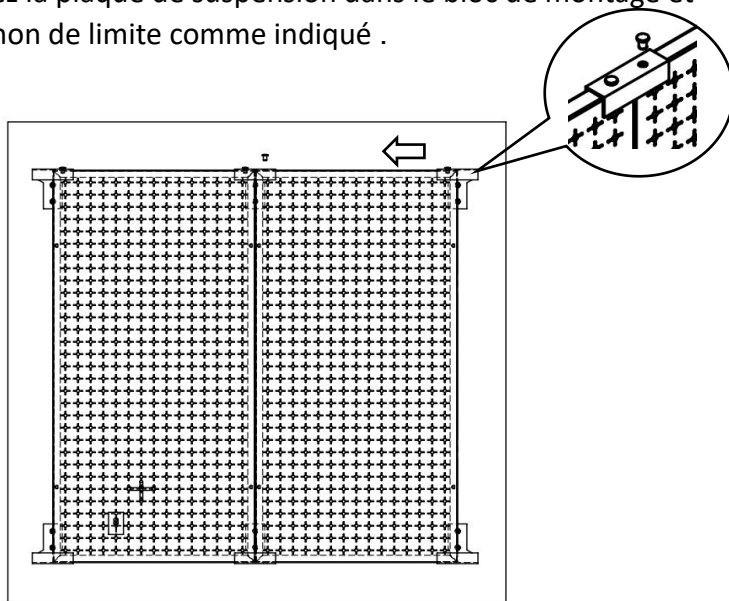

**ÉTAPE 4** : Suivez les étapes ci-dessus pour installer d'autres panneaux perforés .

Une fois l'installation terminée, vous pouvez accrocher vos objets .

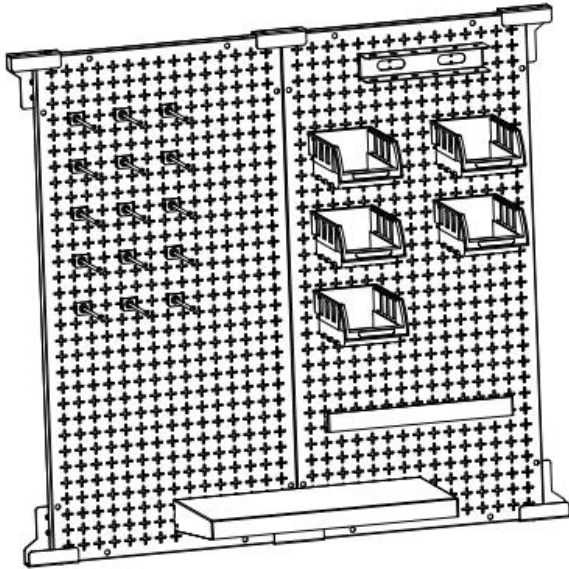

Assemblage de la boîte de rangement :

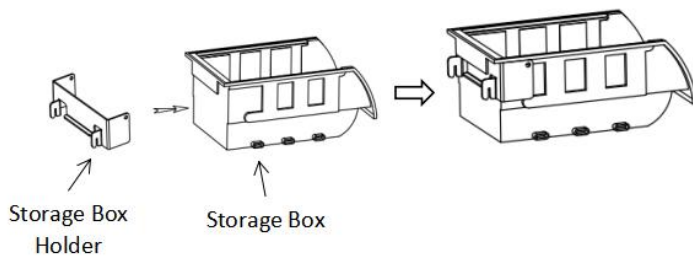

## MAINTENANCE

- Ne pas dépasser le poids capacité .
- Après utilisation, veuillez nettoyer et sécher le produit dans un endroit sec et aéré.

**Fabricant :** Shanghaimuxinmuyeyouxiangongsi

**Adresse :** Shuangchenglu 803nong11hao1602A-1609shi, baoshanqu, Shanghai 200000 CN.

**Importé en Australie :** SIHAO PTY LTD, 1 ROKEVA STREET, ASTWOOD NSW 2122 Australie

**Importé aux États-Unis :** Sanven Technology Ltd., Suite 250, 9166 Anaheim Place, Rancho Cucamonga, CA 91730

<b>EC</b>	<b>REP</b>
-----------	------------

E-CrossStu GmbH  
Mainzer Landstr.69, 60329 Frankfurt am Main.

<b>UK</b>	<b>REP</b>
-----------	------------

YH CONSULTING LIMITED.  
C/O YH Consulting Limited Office 147, Centurion House,  
London Road, Staines-upon-Thames, Surrey, TW18 4AX



**VEVOR**<sup>®</sup>

**TOUGH TOOLS, HALF PRICE**

**Technique Certificat d'assistance et de garantie électronique**

**[www.vevor.com/support](http://www.vevor.com/support)**

# **VEVOR<sup>®</sup>**

**TOUGH TOOLS, HALF PRICE**

Technisch Ondersteuning en E-garantiecertificaat [www.vevor.com/support](http://www.vevor.com/support)

## **PEGBOARD**

## **GEBRUIKSAANWIJZING**

We continue to be committed to provide you tools with competitive price.

"Save Half", "Half Price" or any other similar expressions used by us only represents an estimate of savings you might benefit from buying certain tools with us compared to the major top brands and does not necessarily mean to cover all categories of tools offered by us. You are kindly reminded to verify carefully when you are placing an order with us if you are actually saving half in comparison with the top major brands.

# VEVOR®

TOUGH TOOLS, HALF PRICE

## PEGBOARD

MODEL:HB641601 ,HB641602,HB9632

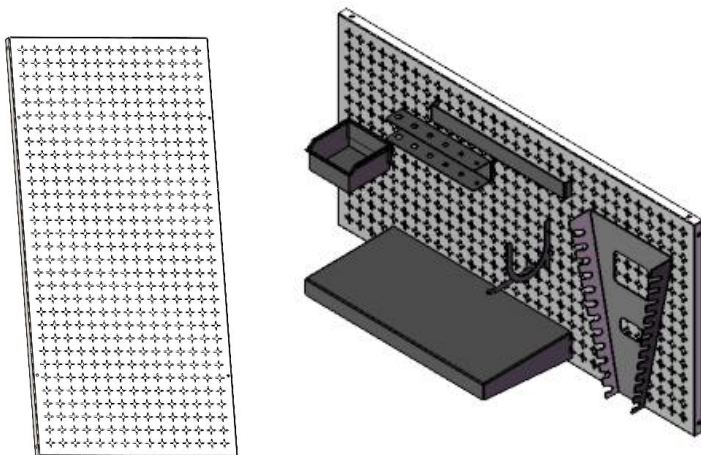

### NEED HELP? CONTACT US!

Have product questions? Need technical support? Please feel free to contact us:

**Technical Support and E-Warranty Certificate**  
[www.vevor.com/support](http://www.vevor.com/support)

This is the original instruction, please read all manual instructions carefully before operating. VEVOR reserves a clear interpretation of our user manual. The appearance of the product shall be subject to the product you received. Please forgive us that we won't inform you again if there are any technology or software updates on our product.



## SAFETY INSTRUCTIONS



### **WAARSCHUWING:**

1. Lees dit materiaal voordat u dit product gebruikt. Als u dit niet doet, kan dit leiden tot ernstig letsel.
2. Overschrijd de werkcapaciteit van de palletvork niet .
3. Na gebruik het product laten drogen voordat u het opbergt, om roestvorming van het product te voorkomen .
4. Procedures die niet specifiek in deze handleiding worden uitgelegd, mogen uitsluitend door een gekwalificeerde technicus worden uitgevoerd.

**Om ernstig letsel door een defect aan het gereedschap te voorkomen, mag u het niet gebruiken als het beschadigd is :**

Het gaatjesbord moet aan een stevige muur worden bevestigd.

De gaatjesborden mogen niet op te dunne houten wanden worden gemonteerd.

De gaatjesborden mogen niet op rotte of losse houten wanden worden geïnstalleerd.

Het gewicht van de op te hangen artikelen mag het draagvermogen van het gaatjesbord niet overschrijden.

Bij het vervangen van de haak moet deze zo worden gekozen dat deze overeenkomt met de maat van het gaatjesbord.

Vermijd scherpe punten, messen en andere voorwerpen die het product kunnen krassen



### **VOORZICHTIGHEID:**

**Lees de instructies en procedures zorgvuldig door voor veilige handelingen.**

**Bewaar deze handleiding**

## MODEL AND PARAMETERS

<b>Model SPEC.</b>	HB641601	HB641602	HB9632
Materiaal	Staal	Staal	Staal
Max. draagvermogen (enkele prikbord)	165 pond	165 pond	165 pond
Afmeting prikbord (L*B)	32 " * 16 "	32 " * 16 "	32 " * 16 "
Gatspecificatie.	1/4 "	1/4 "	1/4 "
Plaatdikte	1,0 mm	1,0 mm	1,0 mm
Oppervlaktebehandeling (prikbord)	Galvaniseren + Poederspuiten	Galvaniseren + Poederspuiten	Galvaniseren + Poederspuiten
Kleur	wit	wit	wit

## COMPONENTS

Model Parts	HB641601	HB641602	HB9632
Pegbord	×2	×2	×3
Haak	/	×15	×20
Opbergdoos	/	×5	×5
Opbergdooshouder	/	× 5	× 5
S bemanningslid houder	/	×1	×1
Rek	/	×1	×1
Plank	/	×1	×2
M ontage blok slot	/	×6	×8
Ik Haak	/	/	×4
Sleutelhouder	/	/	×1
Limietplug	/	× 8	×1 2
Expansieplug	× 8	×1 2	×1 6
Zelftappende schroef	× 8	×1 2	×1 6
Positionering Karton	/	× 1	× 1
Gebruikershandleiding	×1	×1	×1

## INSTALLATION INSTRUCTION

### Vorbereiding van de installatie:

1. Twee of meer personen om het gaatjesbord in elkaar te zetten.
2. Zorg ervoor dat u een tapijt of mat neerlegt om uw vloer te beschermen. U moet alle accessoires goed uitspreiden.
3. Zorg ervoor dat u handschoenen meeneemt om te voorkomen dat u tijdens de installatie krassen oploopt door scherpe onderdelen.
4. Open alle dozen om te controleren of de accessoires compleet en in goede staat zijn .
5. Als u elektrisch gereedschap nodig hebt om dit product te installeren, stel de snelheid dan vooraf in op een lage snelheid.
6. bij de installatie voor dat alle gaten op één lijn liggen en draai niet eerst alle schroeven vast , anders kan de installatie lastiger worden.

### Voor installatie van betonnen muren

**STAP 1:** Plaats het hangbord bij de geïnstalleerde muur en markeer de gaten met een dunne spijker of potlood. (Let op: twee gaten aan de linkerkant, twee gaten aan de rechterkant)

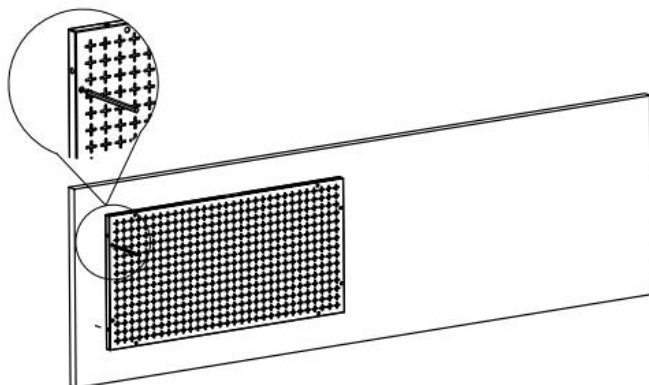

**STAP 2:** Boor gaten met een diameter van 8 mm en een diepte van 40 mm op de gemarkeerde plaatsen. (Let op: zorg dat u uw eigen boorgereedschap bij de hand hebt .)

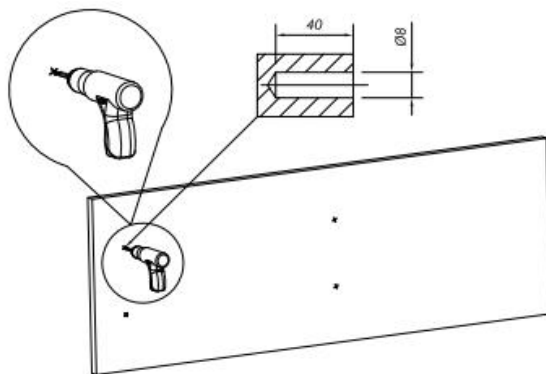

**STAP 3:** Spijker de vier expansiepluggen volledig in het gat.

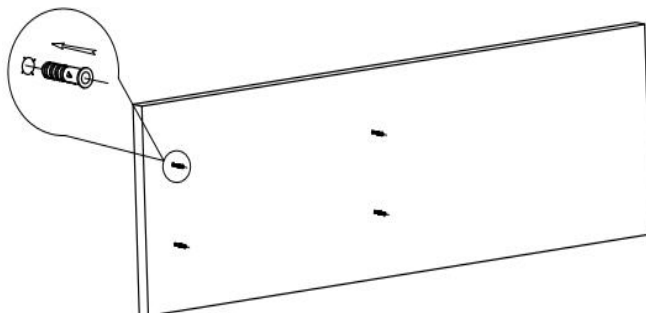

**STAP 4 :** Draai de zelftappende schroef in het gat van de expansieplug en laat 3 tot 5 mm vrij.

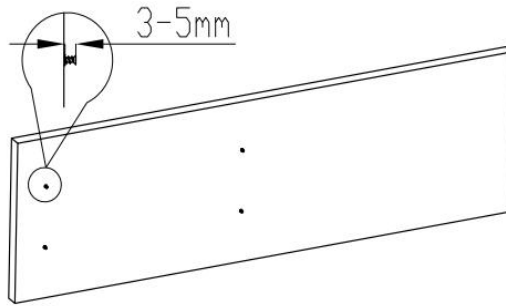

**STAP 5:** Hang het gaatjesbord aan de zelftappende schroeven, zoals op de afbeelding te zien is.

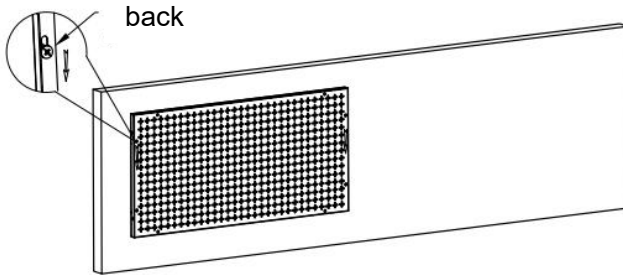

**STAP 6:** Zorg ervoor dat de vier zelftappende schroeven in de bevestigingsgaten van het gaatjesbord hangen en draai de zelftappende schroeven vast.

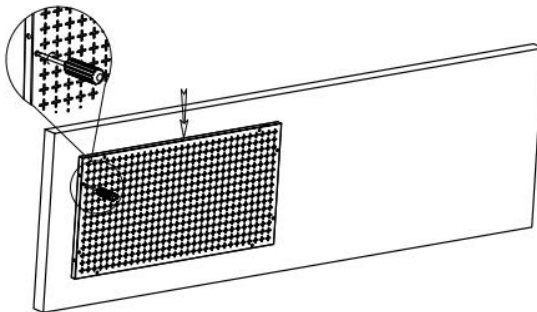

**STAP 7:** Volg de bovenstaande stappen om andere gaatjesborden te installeren.

(Let op: het gaatjesbord kan horizontaal en verticaal worden geplaatst en de installatiemethode is hetzelfde.)

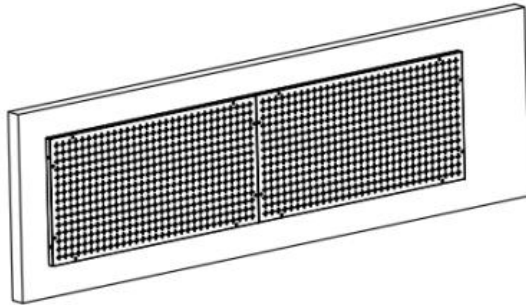

## Voor installatie van houten wandpalen

**STAP 1 :** Lijn de rand van het gaatjesbord uit met de middellijn van de paal en markeer de gaten met een dunne spijker of potlood. (Let op: twee gaten aan de linkerkant, twee gaten aan de rechterkant)

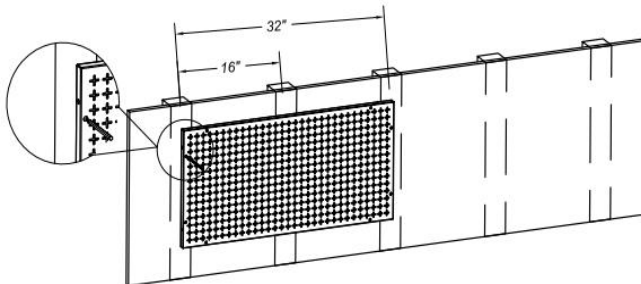

**STAP 2:** Boor gaten met een diameter van 3 mm en een diepte van 40 mm op de gemarkeerde plaatsen. Draai de zelftappende schroef in de gaten en laat 3 tot 5 mm uitsteken. (Let op: zorg dat u uw eigen gereedschap bij de hand hebt .)

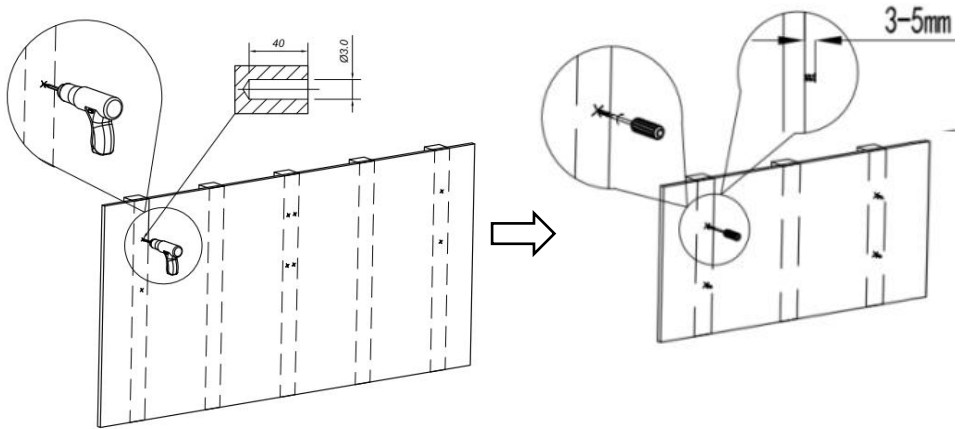

**STAP 3 :** Hang het gaatjesbord aan de zelftappende schroeven , zoals op de afbeelding te zien is.

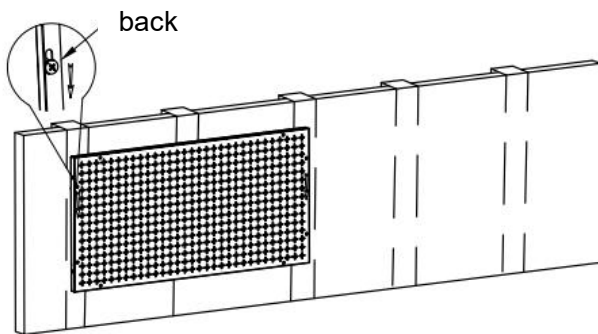

**STAP 4 :** Zorg ervoor dat de vier zelftappende schroeven in de montagegaten van het gaatjesbord hangen en draai de zelftappende schroeven vast .



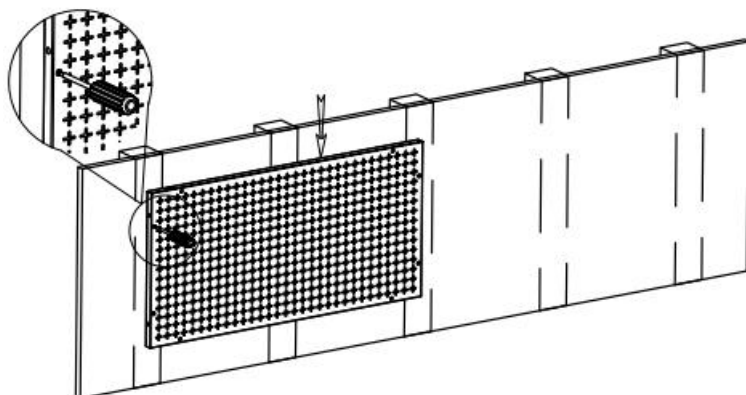

**STAP 5** : Volg de bovenstaande stappen om andere gaatjesborden te installeren.

(Let op: het gaatjesbord kan horizontaal en verticaal worden geplaatst en de installatiemethode is hetzelfde.)

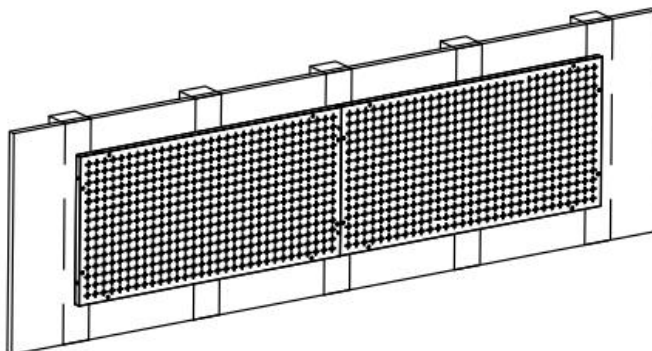

### Voor Montageblok + Betonnen Muur Installatie

**STAP 1:** Leg het positioneringskarton op de te installeren muur en boor de markeergaten volgens de gemarkeerde gaten op het positioneringskarton.

Haal het karton weg en boor gaten met een diameter van 8 mm en een diepte van 40 mm op de plaats van de gemarkeerde gaten. (Let op: zorg dat u uw eigen boorgereedschap bij de hand hebt.)

Spijker de expansiepluggen volledig in het gat.

Verticaal:  $A=406\text{mm}$

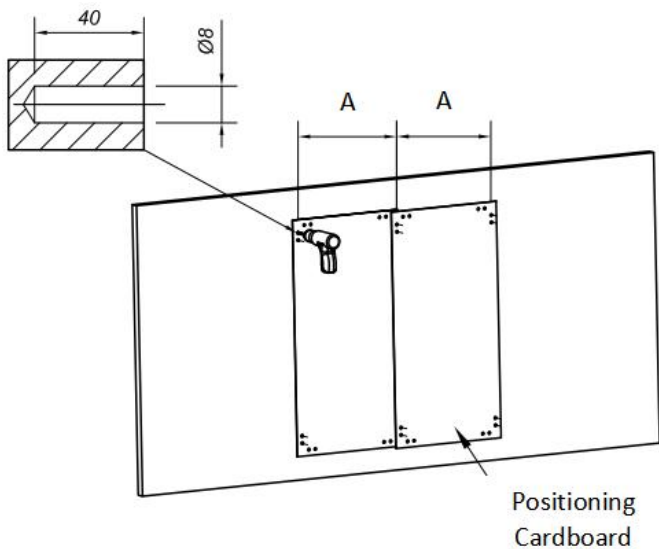

Horizontaal:  $B=814\text{mm}$

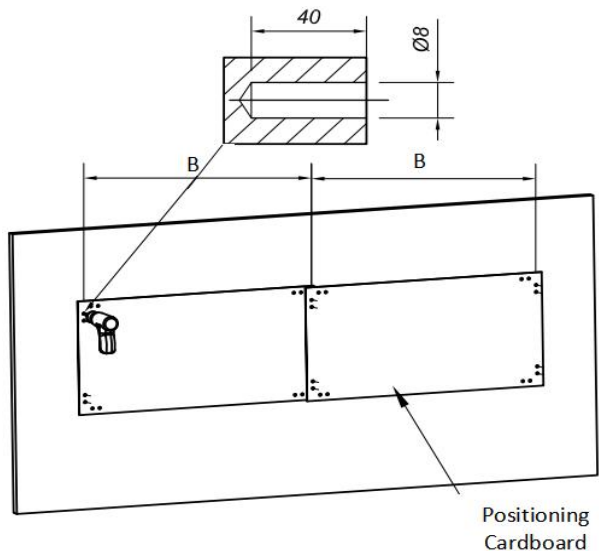

**STAP 2:** Bevestig het montageblok met zelftappende schroeven zoals afgebeeld ( verticaal ).

Let op: Horizontale en verticale installatiemethoden zijn hetzelfde.

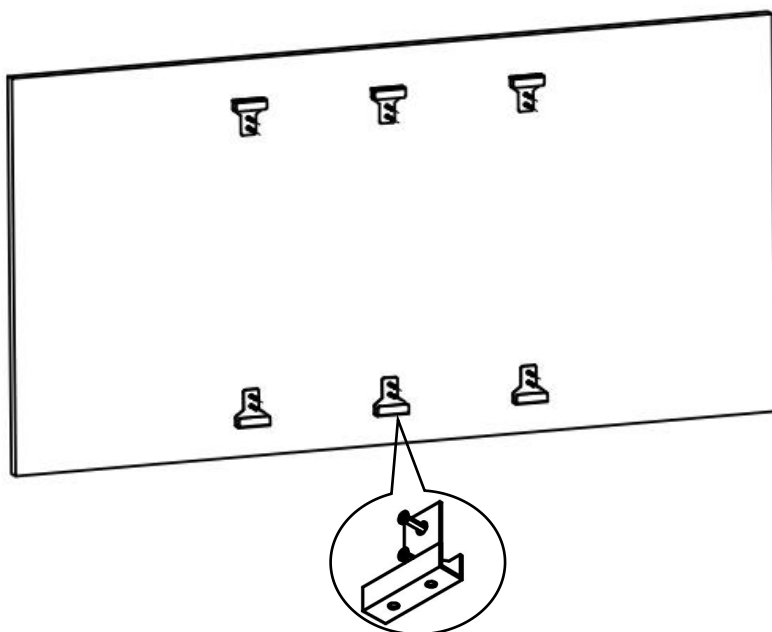

**STAP 3 :** Plaats de ophangplaat in het montageblok en sluit de eindplug aan zoals afgebeeld .

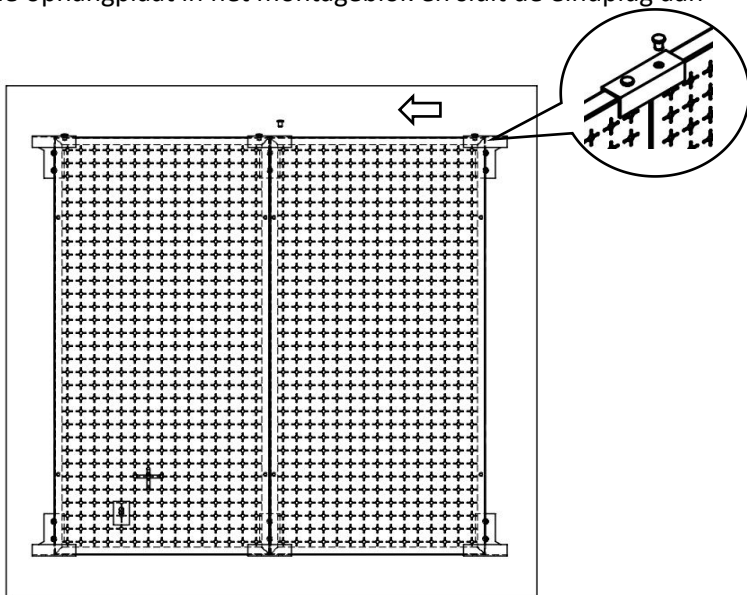

**STAP 4:** Volg de bovenstaande stappen om andere gaatjesborden te installeren .

Zodra de installatie voltooid is, kunt u uw spullen ophangen .

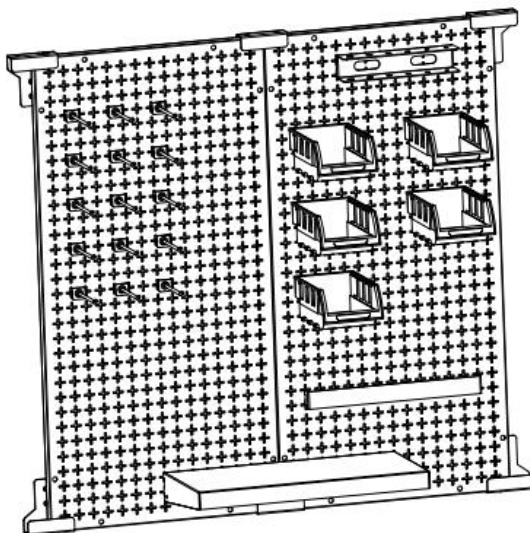

## Voor Montageblok + houten muurpaalinstallatie

**STAP 1** : Leg het positioneringskarton op de te installeren muur en zorg dat het midden van het gat in het karton zich op de middellijn van de paal bevindt.

Boor de markeergaten volgens de gaten die op het positioneringskarton zijn gemarkeerd.

Haal het karton weg en boor gaten met een diameter van 3 mm en een diepte van 40 mm op de plaats van de gemarkeerde gaten. (Let op: zorg dat u uw eigen boorgereedschap bij de hand hebt .)

Verticaal: A=406mm

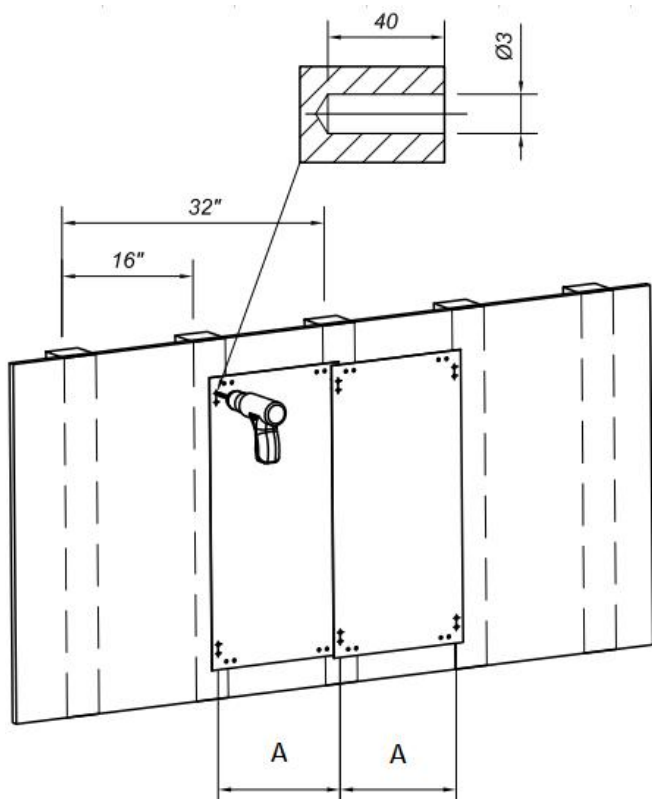

Horizontaal : B=814mm

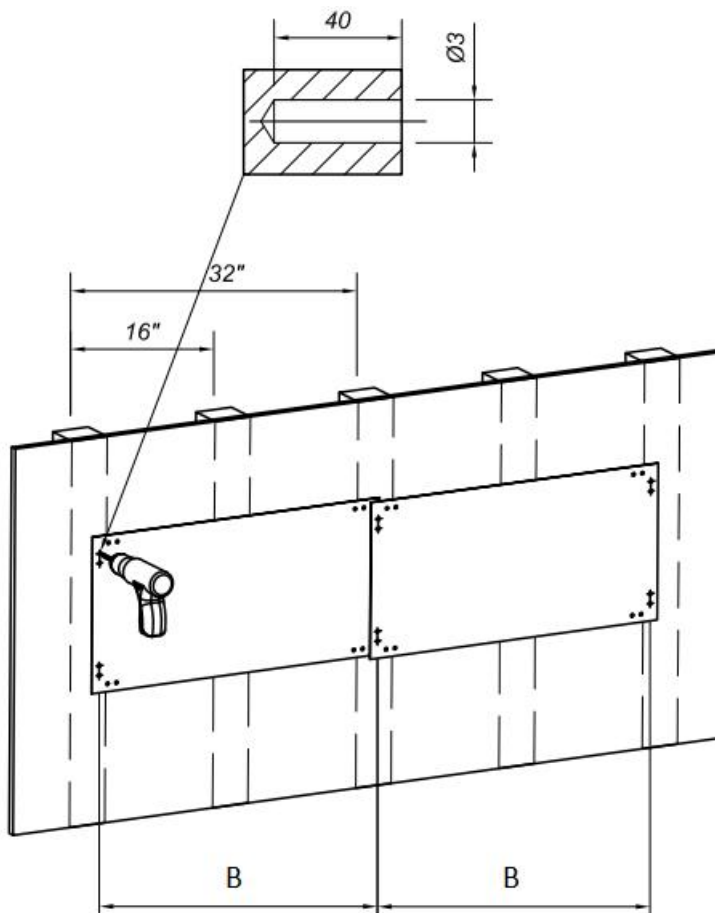

**STAP 2** : Bevestig het montageblok met zelftappende schroeven zoals afgebeeld ( verticaal ) .

Let op: Horizontale en verticale installatiemethoden zijn hetzelfde.

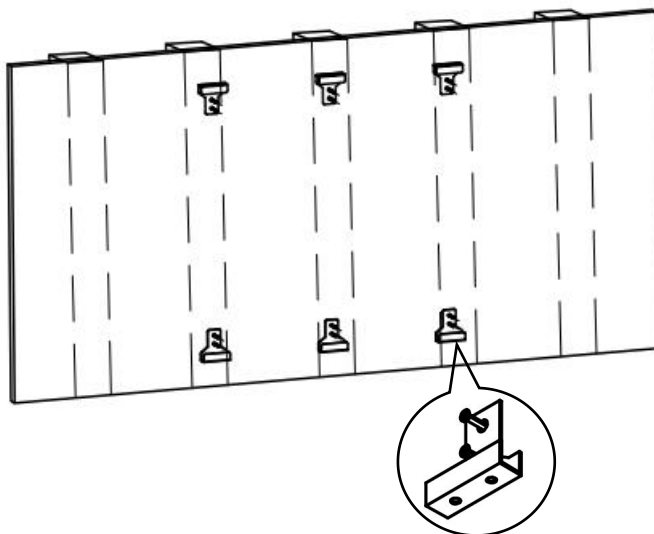

**STAP 3** : Plaats de ophangplaat in het montageblok en sluit de eindplug aan zoals afgebeeld .

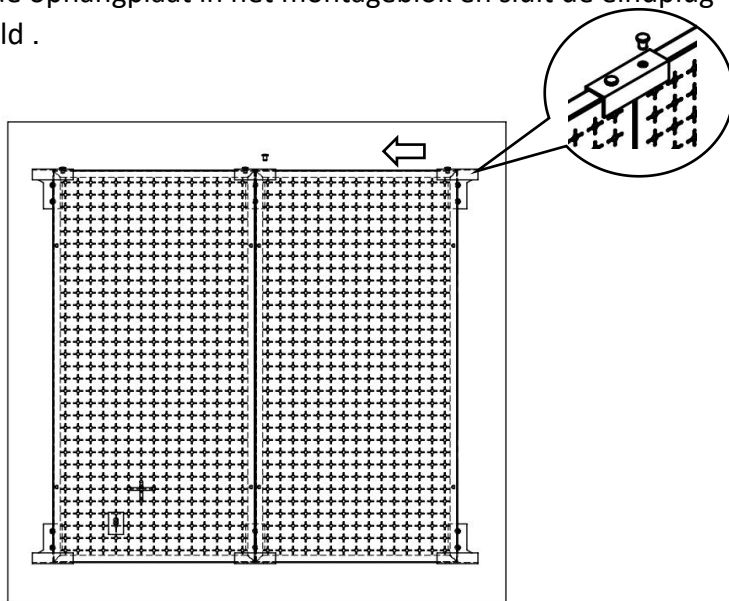

**STAP 4**: Volg de bovenstaande stappen om andere gaatjesborden te installeren .



Zodra de installatie voltooid is, kunt u uw spullen ophangen .

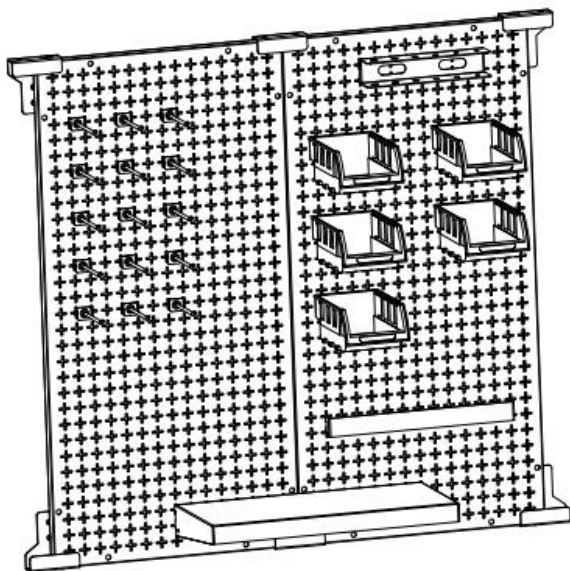

Montage van de opbergdoos:

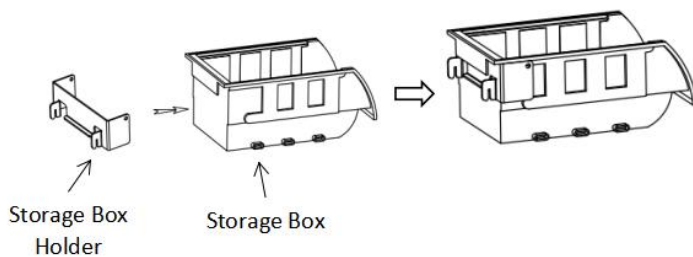

## MAINTENANCE

- Overschrijd het gewicht niet capaciteit .
- Na gebruik het product schoonmaken en laten drogen op een droge, geventileerde plaats.

**Fabrikant:** Shanghaimuxinmuyeyouxiangongsi

**Adres:** Shuangchenglu 803nong11hao1602A-1609shi, baoshanqu, shanghai 200000 CN.

**Geïmporteerd naar AUS:** SIHAO PTY LTD, 1 ROKEVA STREETEASTWOOD NSW 2122 Australië

**Geïmporteerd naar de VS:** Sanven Technology Ltd., Suite 250, 9166 Anaheim Place, Rancho Cucamonga, CA 91730

<b>EC</b>	<b>REP</b>
-----------	------------

E-CrossStu GmbH  
Mainzer Landstr.69, 60329 Frankfurt am Main.

<b>UK</b>	<b>REP</b>
-----------	------------

YH CONSULTING LIMITED.  
C/O YH Consulting Limited Office 147, Centurion House,  
London Road, Staines-upon-Thames, Surrey, TW18 4AX



**VEVOR**<sup>®</sup>

**TOUGH TOOLS, HALF PRICE**

**Technisch Ondersteuning en E-garantiecertificaat**

**[www.vevor.com/support](http://www.vevor.com/support)**

# **VEVOR<sup>®</sup>**

**TOUGH TOOLS, HALF PRICE**

Teknisk Support och e-garanticertifikat [www.vevor.com/support](http://www.vevor.com/support)

## **PEGBOARD**

# **ANVÄNDARMANUAL**

We continue to be committed to provide you tools with competitive price.

"Save Half", "Half Price" or any other similar expressions used by us only represents an estimate of savings you might benefit from buying certain tools with us compared to the major top brands and does not necessarily mean to cover all categories of tools offered by us. You are kindly reminded to verify carefully when you are placing an order with us if you are actually saving half in comparison with the top major brands.

# VEVOR®

TOUGH TOOLS, HALF PRICE

## PEGBOARD

MODELL: HB641601 , HB641602, HB9632

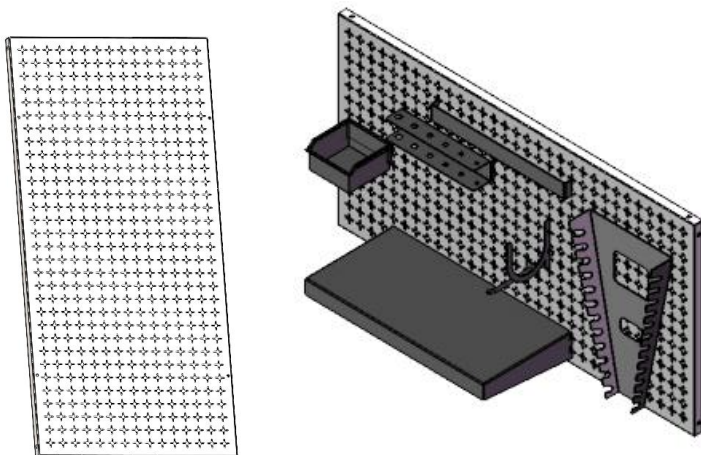

### NEED HELP? CONTACT US!

Have product questions? Need technical support? Please feel free to contact us:

**Technical Support and E-Warranty Certificate**  
[www.vevor.com/support](http://www.vevor.com/support)

This is the original instruction, please read all manual instructions carefully before operating. VEVOR reserves a clear interpretation of our user manual. The appearance of the product shall be subject to the product you received. Please forgive us that we won't inform you again if there are any technology or software updates on our product.

## SAFETY INSTRUCTIONS



### **VARNING:**

1. Läs detta material innan du använder denna produkt. Underlåtenhet att göra det kan resultera i allvarliga skador.
- 2 . Överskrid inte arbetskapaciteten för pallgaffeln .
- 3 . Efter användning, vänligen torka före förvaring för att undvika att produkten rostar .
- 4 . Procedurer som inte specifikt förklaras i denna handbok får endast utföras av en kvalificerad tekniker.

### **För att förhindra allvarliga skador från verktygsfel, använd inte när det är skadat :**

Plåtbrädan måste monteras på en solid vägg.

Pinnbrädorna ska inte monteras på för tunna träväggar.

Pinnbrädorna får inte monteras på ruttna eller lösa träväggar.

Vikten av föremålen som ska hängas får inte överstiga belastningen på stiftbrädan.

Vid byte av kroken måste den väljas för att matcha storleken på pinnbrädan.

Undvik vassa spetsar, knivar och andra föremål för att repa produkten



### **FÖRSIKTIGHET:**

**Läs noggrant instruktionerna och procedurerna för säker drift.**

**Spara denna manual**

## MODEL AND PARAMETERS

<b>Model SPEC.</b>	HB641601	HB641602	HB9632
Material	Stål	Stål	Stål
Max. viktkapacitet (enkel stiftbräda)	165 pund	165 pund	165 pund
Pinnboard Storlek (L*W)	32 " * 16 "	32 " * 16 "	32 " * 16 "
Hål Spec.	1/4 "	1/4 "	1/4 "
Plåttjocklek	1,0 mm	1,0 mm	1,0 mm
Ytbehandling (pinnebräda)	Galvanisering+Pulverspr utning	Galvanisering+Pulverspr utning	Galvanisering+Pulverspr utning
Färg	vit	vit	vit



## COMPONENTS

Model Parts	HB641601	HB641602	HB9632
Pinbräda	×2	×2	×3
H ook	/	×15	×20
S lagringslåda	/	×5	×5
Förvaringsboxhållare	/	× 5	× 5
S besättningsförare Hållare	/	×1	×1
R ack	/	×1	×1
Hylla	/	×1	×2
Montering B lås	/	×6	×8
U H ook	/	/	×4
W rench H äldre	/	/	×1
Limit Plug	/	× 8	×12
Expansionsplugg	× 8	×12	×16
Självgående Skruv	× 8	×12	×16
Positionerande kartong	/	× 1	× 1
Användarmanual	×1	×1	×1

## INSTALLATION INSTRUCTION

### Installationsförberedelser:

1. Två eller flera personer för att montera stiftbrädan.
2. Förbered en matta eller matta för att skydda ditt golv du behöver för att sprida ut alla tillbehör.
3. Förbered handskar för att undvika repor av vassa delar som kan uppstå under installationen.
4. Öppna alla rutorna för att kontrollera om tillbehören är kompletta och i gott skick .
5. Om du behöver använda elverktyg för att installera den här produkten, ställ in hastigheten på låg hastighet i förväg.
6. När du installerar , vänligen rikta in alla hål och dra inte åt alla skruvar först , annars kan det försvåra installationen.

### För betongvägginstallation

**STEG 1:** Placera hängbrädan nära den installerade väggen och markera hålen med en fin spik eller penna.(Obs: Två hål till vänster, två hål till höger)

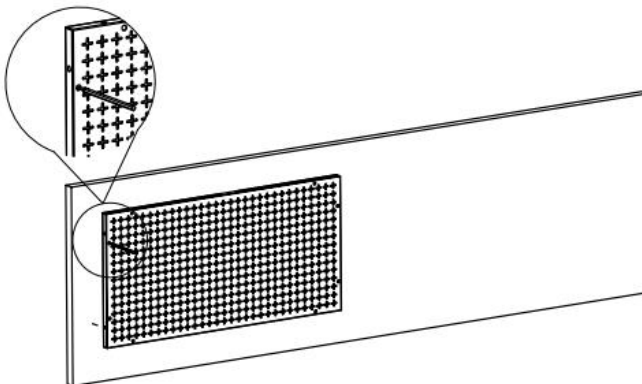

**STEG 2:** Borra hål med en diameter på 8 mm och ett djup på 40 mm på de markerade platserna. (Obs: Förbered dina egna borrarverktyg .)

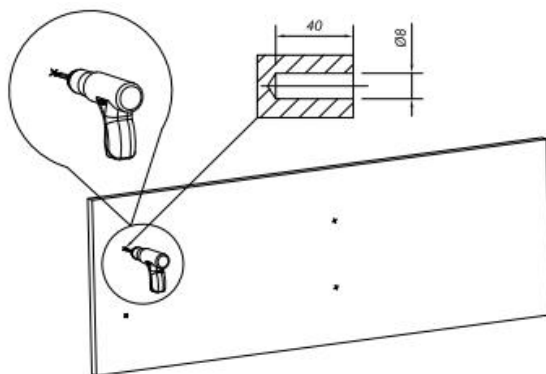

**STEG 3:** Spika fast de fyra expansionspluggarna helt i hålet.

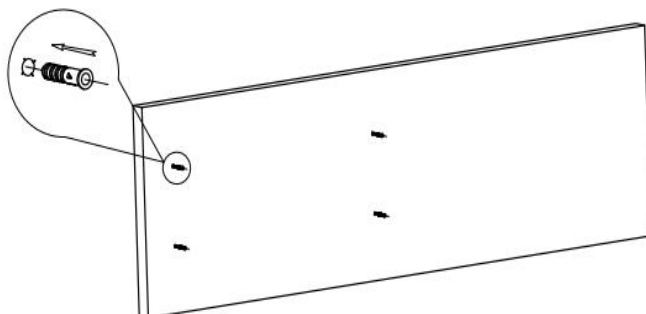

**STEG 4 :** Skruva in den självgångande skruven i expansionspluggens hål, lämna 3~5 mm fri.

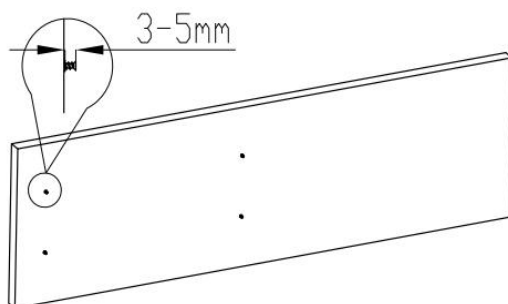

**STEG 5:** Häng pinnbrädan på de självgående skruvarna, som visas på bilden.

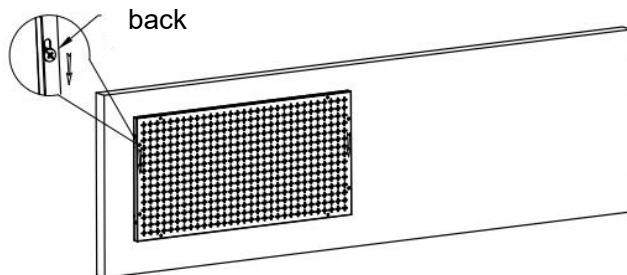

**STEG 6:** Se till att de fyra självgående skruvarna hängs i monteringshålerna på stiftbrädan och dra åt de självgående skruvarna.

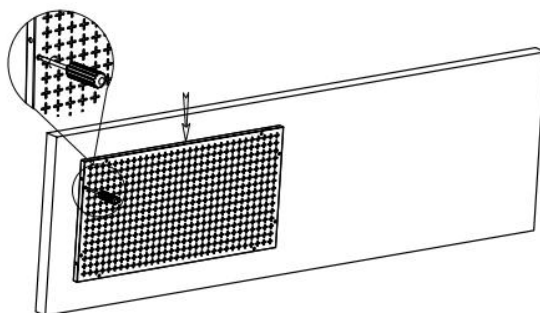

**STEG 7:** Följ stegen ovan för att installera andra pegboards.  
(Obs: Plåtbrädan placeras horisontellt och vertikalt, och installationsmetoden är densamma.)

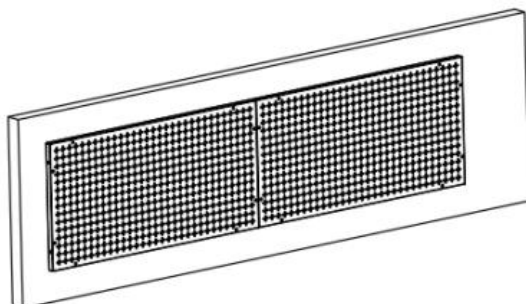

## För montering av träväggstolpar

**STEG 1 :** Rikta in pinnbrädans kant med mittlinjen på stolpen och markera hålen med en fin spik eller penna. (Obs: Två hål till vänster, två hål till höger)

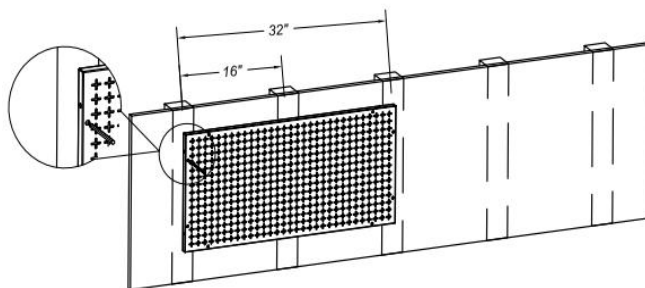

**STEG 2:** Borra hål 3 mm i diameter och 40 mm i djup på de markerade platserna, skruva in den självgående skruven i hålen, lämna 3~5 mm exponerade. (Obs: Förbered dina egna verktyg .)

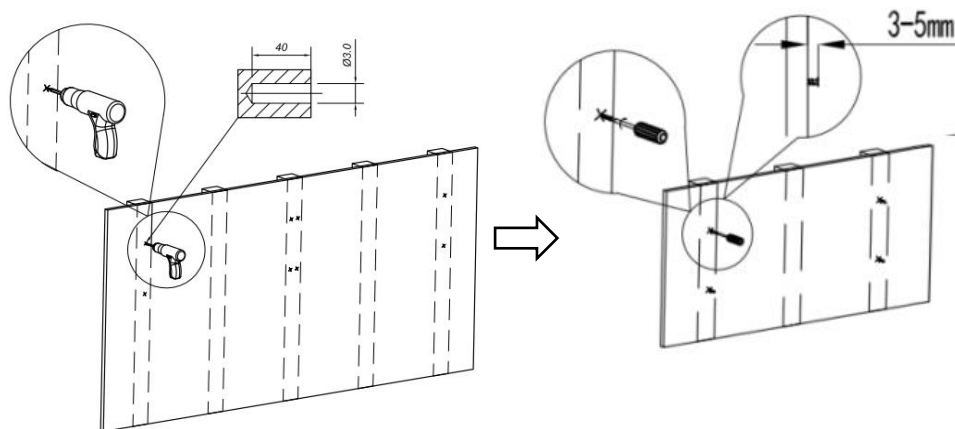

**STEG 3 :** Häng pinnbrädan på de självgåande skruvarna s, som visas

på bilden.

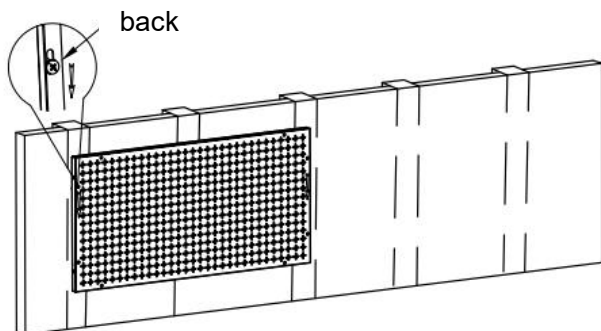

**STEG 4** : Se till att de fyra självgående skruvarna hängs i monteringshålerna på stiftbrädan och dra åt de självgående skruvarna .

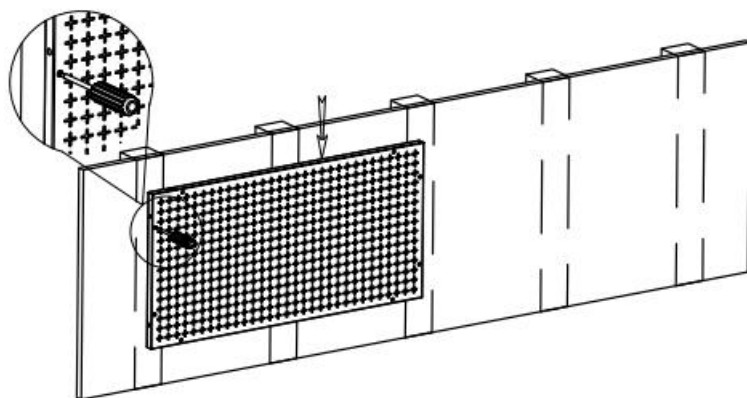

**STEG 5** : Följ stegen ovan för att installera andra pegboards.  
(Obs: Plåtbrädan placeras horisontellt och vertikalt, och installationsmetoden är densamma.)

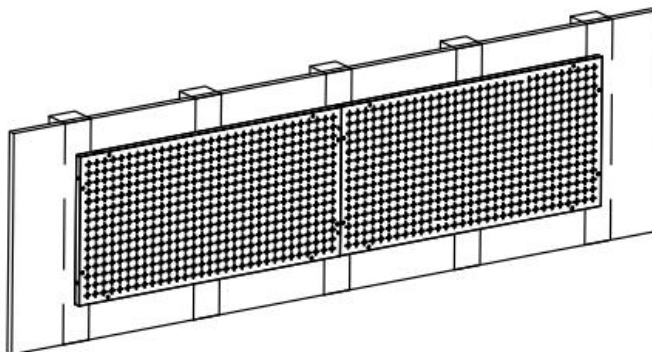

## För Montering B lås + Montering av betongvägg

**STEG 1:** Lägg positioneringspappen på väggen som ska installeras, borra markeringshål enligt hålen markerade på positioneringspappen. Ta bort kartong och borra hål 8 mm i diameter och 40 mm djupa vid markeringshålen. (Obs: Förbered dina egna borrarverktyg .)  
Spika fast expansionspluggarna helt i hålet.

Vertikal: A=406mm

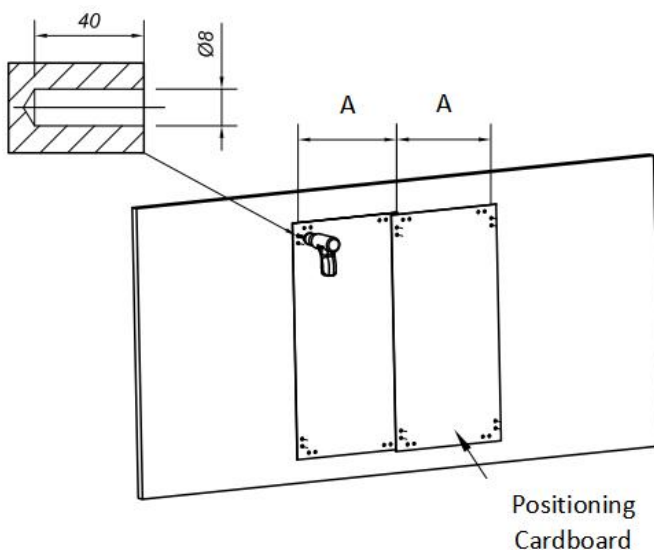

Horisontell: B=814mm

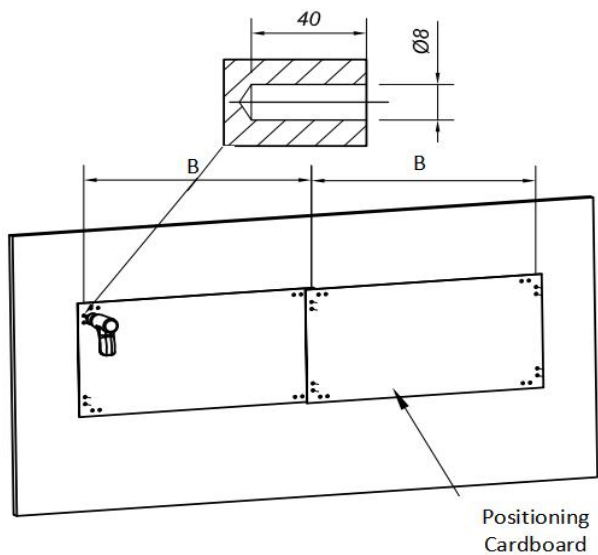

**STEG 2:** Fäst monteringsblocket med självgående skruvar enligt bilden ( Vertikal ).

Obs: Horisontell och vertikal installationsmetod är densamma.

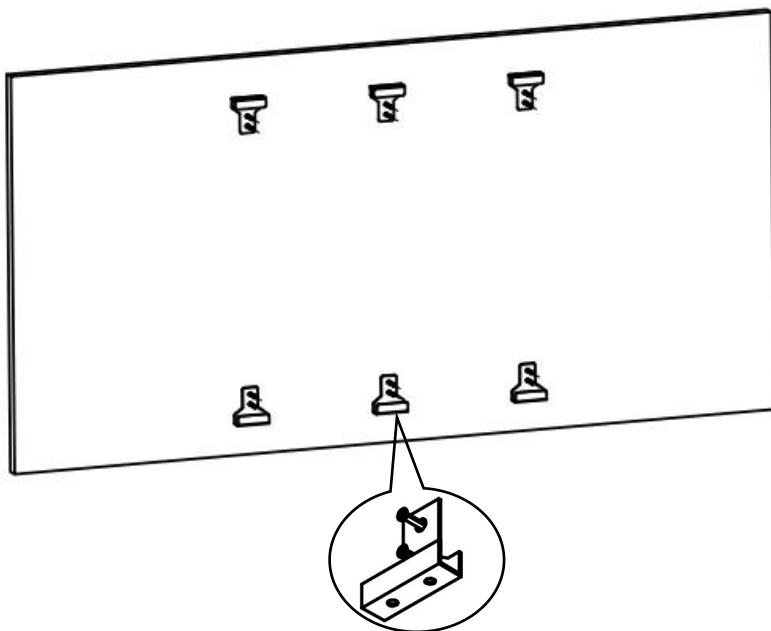



**STEG 3 :** Sätt in hängplattan i monteringsblocket och sätt i gränspluggen enligt bilden .

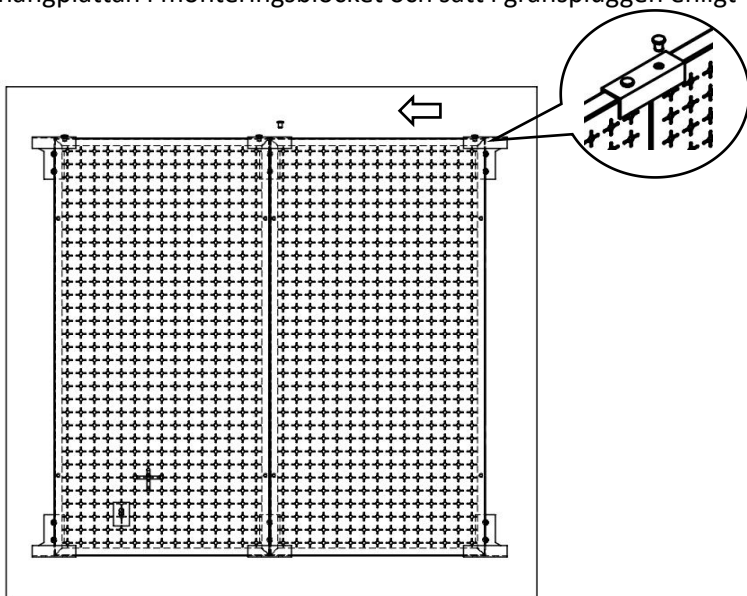

**STEG 4:** Följ stegen ovan för att installera andra stiftbrädor .

När installationen är klar kan du hänga dina föremål .

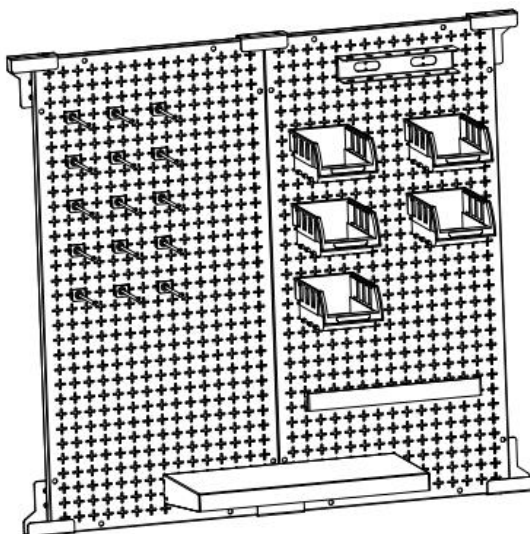

## För Montering B lås + Träväggstolpeinstallation

**STEG 1** : Lägg positioneringspappen på väggen som ska installeras, och mitten av hålet på kartongen är placerat på stolpens mittlinje.

Borra markeringshålen enligt hålen markerade på positioneringspappen.

Ta bort kartong och borra hål 3 mm i diameter och 40 mm djupa vid märkningshålen.(Obs: Förbered dina egna borrarverktyg .)

Vertikal: A=406mm

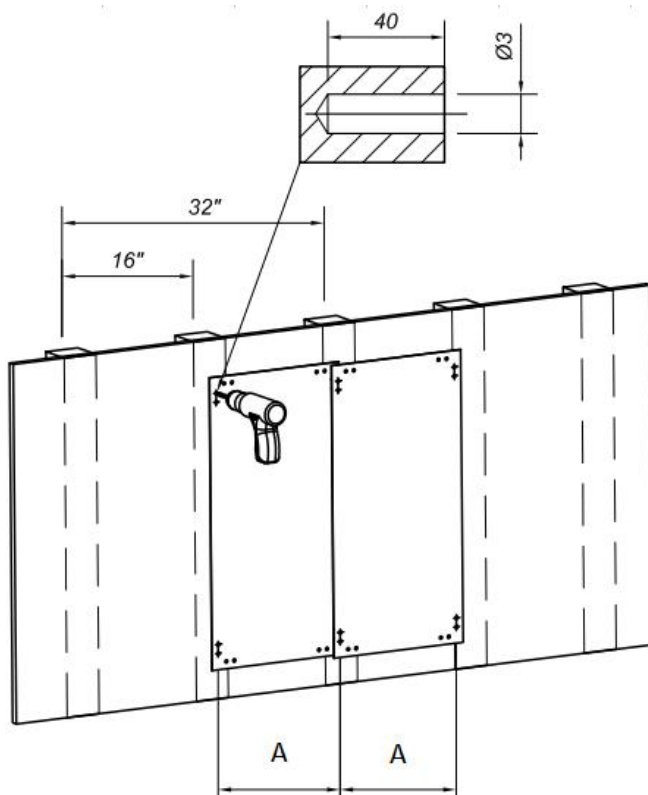

Horisontell : B=814mm

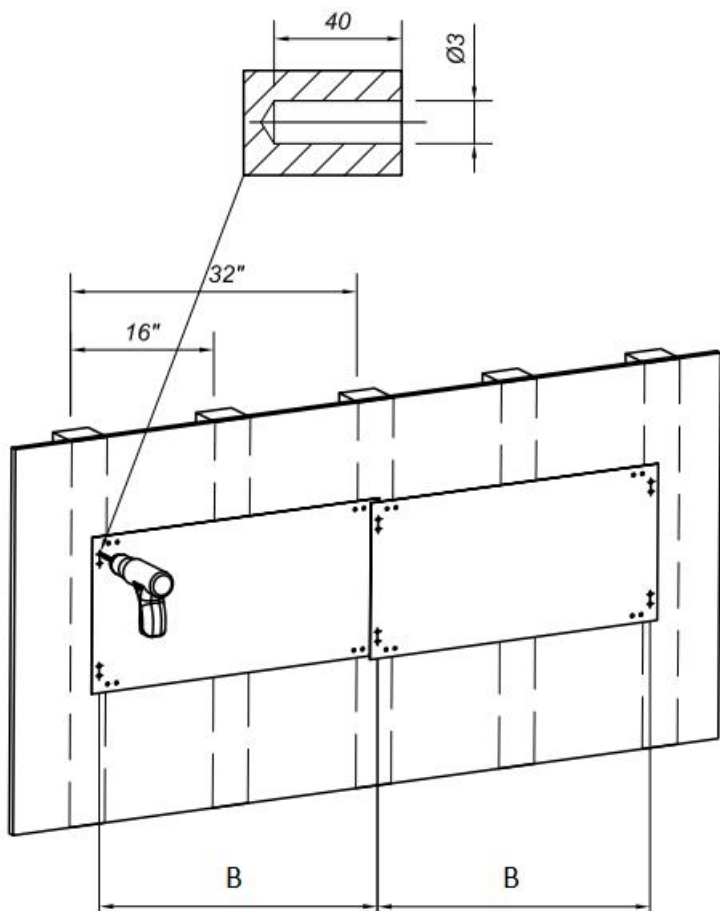

**STEG 2** : Fäst monteringsblocket med självgående skruvar enligt bilden ( Vertikal ) .

Obs: Horisontell och vertikal installationsmetod är densamma.

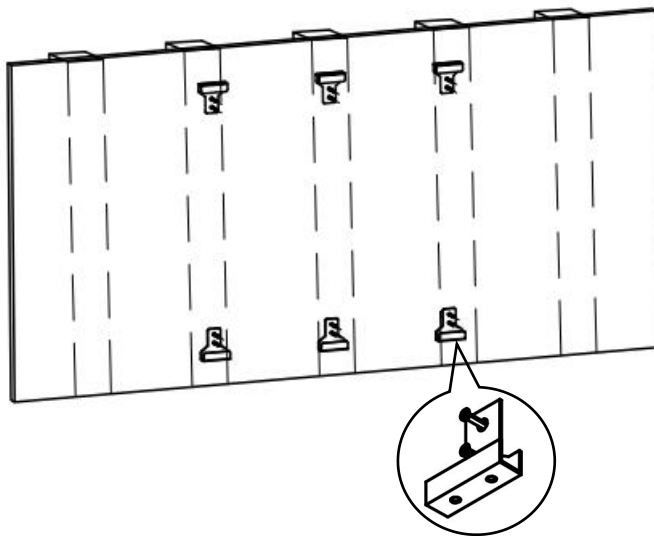

**STEG 3** : Sätt in hängplattan i monteringsblocket och sätt i gränspluggen enligt bilden .

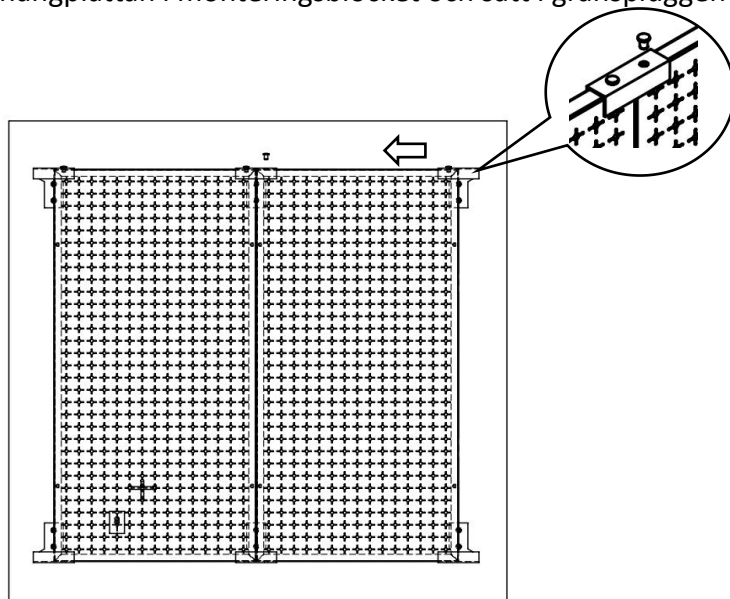

**STEG 4:** Följ stegen ovan för att installera andra stiftbrädor .

När installationen är klar kan du hänga dina föremål .

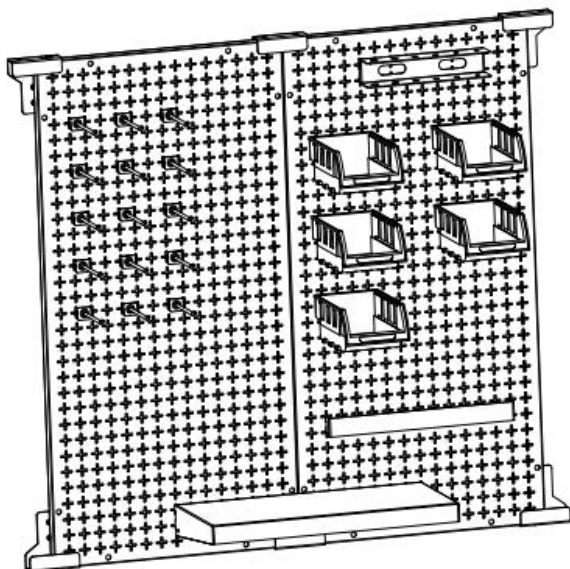

Förvaringslåda montering:

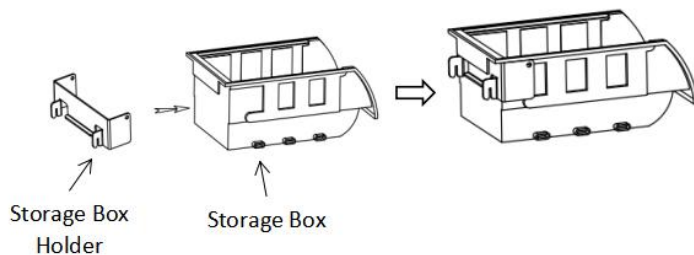

## MAINTENANCE

- Överskrid inte vikten kapacitet .
- Efter användning, rengör och torka produkten på en torr och ventilerad plats.

**Tillverkare:** Shanghaimuxinmuyeyouxiangongsi

**Adress:** Shuangchenglu 803nong11hao1602A-1609shi, baoshanqu, shanghai 200000 CN.

**Importerad till AUS:** SIHAO PTY LTD, 1 ROKEVA STREETEASTWOOD NSW 2122 Australien

**Importerad till USA:** Sanven Technology Ltd., Suite 250, 9166 Anaheim Place, Rancho Cucamonga, CA 91730

EC	REP
----	-----

E-CrossStu GmbH  
Mainzer Landstr.69, 60329 Frankfurt am Main.

UK	REP
----	-----

YH CONSULTING LIMITED.  
C/O YH Consulting Limited Office 147, Centurion House,  
London Road, Staines-upon-Thames, Surrey, TW18 4AX



**VEVOR<sup>®</sup>**

**TOUGH TOOLS, HALF PRICE**

**Teknisk Support och e-garanticertifikat**

**[www.vevor.com/support](http://www.vevor.com/support)**



# **VEVOR<sup>®</sup>**

## **TOUGH TOOLS, HALF PRICE**

Técnico Soporte y certificado de garantía electrónica [www.vevor.com/support](http://www.vevor.com/support)

### **TABLERO**

## **MANUAL DE USUARIO**

We continue to be committed to provide you tools with competitive price.

"Save Half", "Half Price" or any other similar expressions used by us only represents an estimate of savings you might benefit from buying certain tools with us compared to the major top brands and does not necessarily mean to cover all categories of tools offered by us. You are kindly reminded to verify carefully when you are placing an order with us if you are actually saving half in comparison with the top major brands.

# VEVOR®

TOUGH TOOLS, HALF PRICE

## PEGBOARD

MODELO:HB641601 ,HB641602,HB9632

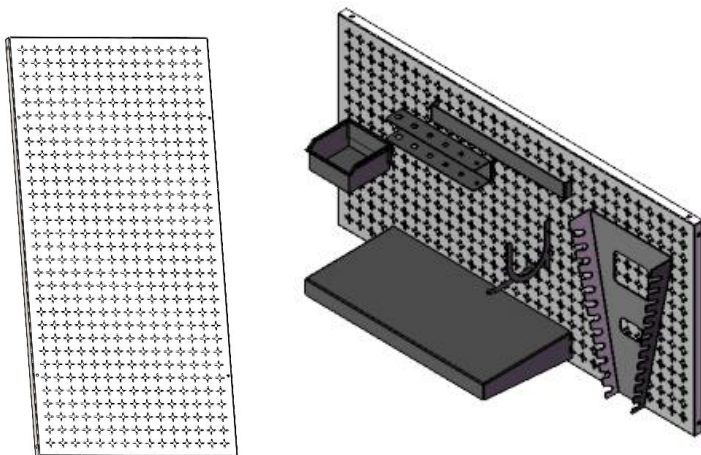

### NEED HELP? CONTACT US!

Have product questions? Need technical support? Please feel free to contact us:

**Technical Support and E-Warranty Certificate**  
[www.vevor.com/support](http://www.vevor.com/support)

This is the original instruction, please read all manual instructions carefully before operating. VEVOR reserves a clear interpretation of our user manual. The appearance of the product shall be subject to the product you received. Please forgive us that we won't inform you again if there are any technology or software updates on our product.

## SAFETY INSTRUCTIONS



### **ADVERTENCIA:**

1. Lea este material antes de utilizar este producto. De lo contrario, podría sufrir lesiones graves.
2. No exceda la capacidad de trabajo de la horquilla para paletas .
3. Después del uso, séquelo antes de guardarlo para evitar la oxidación del producto .
4. Los procedimientos no explicados específicamente en este manual deben ser realizados únicamente por un técnico calificado.

**Para evitar lesiones graves debido a fallas de la herramienta, no la utilice si está dañada :**

El tablero perforado debe montarse en una pared sólida.

Los tableros perforados no se deben instalar en paredes de madera demasiado delgadas.

Los tableros perforados no se deben instalar en paredes de madera podridas o sueltas.

El peso de los objetos a colgar no debe superar la carga del tablero perforado.

Al reemplazar el gancho, debe seleccionarse para que coincida con el tamaño del tablero perforado.

Evite puntas afiladas, cuchillas y otros elementos que rayen el producto.



### **PRECAUCIÓN:**

**Lea atentamente las instrucciones y los procedimientos para realizar operaciones seguras.**

**Guarde este manual**

## MODEL AND PARAMETERS

<b>Model SPEC.</b>	HB641601	HB641602	HB9632
Material	Acero	Acero	Acero
Capacidad máxima de peso (tablero perforado simple)	165 libras	165 libras	165 libras
Tamaño del tablero perforado (L*A)	32 " * 16 "	32 " *16 "	32 " *16 "
Especificaciones del agujero.	1/4 "	1/4 "	1/4 "
Espesor de la chapa	1,0 mm	1,0 mm	1,0 mm
Tratamiento de superficies (tablero perforado)	Galvanización + Pulverización de polvo	Galvanización + Pulverización de polvo	Galvanización + Pulverización de polvo
Color	blanco	blanco	blanco

## COMPONENTS

Model Parts	HB641601	HB641602	HB9632
Tablero perforado	×2	×2	×3
Gancho	/	×15	×20
Caja de almacenamiento	/	×5	×5
Soporte para caja de almacenamiento	/	× 5	× 5
de tripulación S Holder	/	×1	×1
Estante	/	×1	×1
Estante	/	×1	×2
Bloque de montaje	/	×6	×8
tú Gancho	/	/	×4
Porta llaves	/	/	×1
Tapón de límite	/	× 8	×1 2
Tapón de expansión	× 8	×1 2	×1 6
Tornillo autorroscante	× 8	×1 2	×1 6

Posicionamiento de cartón	/	x 1	x 1
M anual del usuario	x1	x1	x1

## INSTALLATION INSTRUCTION

### Preparación de la instalación:

1. Se necesitan dos o más personas para montar el tablero perforado.
2. Prepare una alfombra o tapete para proteger el piso donde necesita distribuir todos los accesorios.
3. Prepare guantes para evitar rayarse con las piezas afiladas que puedan producirse durante la instalación.
4. Abra todas las cajas para comprobar si los accesorios están completos y en buenas condiciones .
5. Si necesita utilizar herramientas eléctricas para instalar este producto, configure la velocidad a baja con antelación.
6. Al instalar , alinee todos los orificios y no apriete todos los tornillos primero , de lo contrario, podría dificultar la instalación.

### Para instalación en paredes de hormigón

**PASO 1:** Coloque el tablero colgante cerca de la pared instalada y marque los agujeros con un clavo fino o un lápiz. (Nota: dos agujeros a la izquierda, dos agujeros a la derecha)

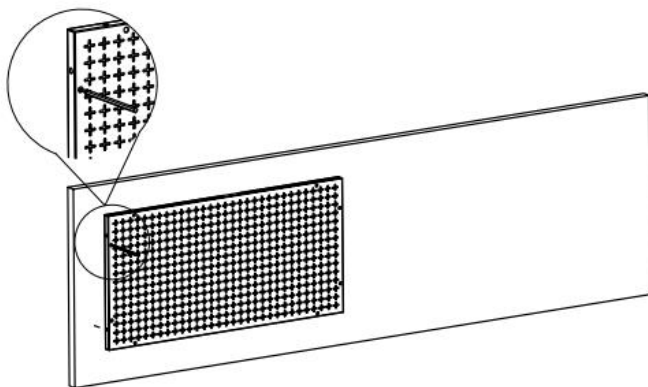

**PASO 2:** Perfore agujeros de 8 mm de diámetro y 40 mm de profundidad en los lugares marcados. (Nota: Prepare sus propias herramientas de perforación ).

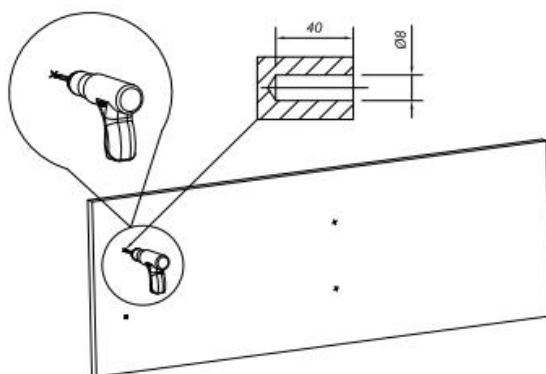

**PASO 3:** Clave los cuatro tapones de expansión completamente en el orificio.

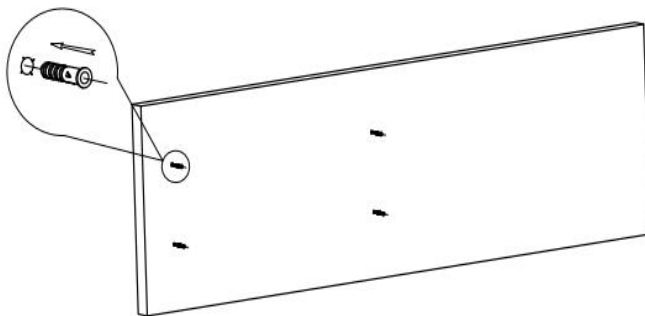

**PASO 4 :** Atornille el tornillo autorroscante en el orificio del tapón de expansión, dejando entre 3 y 5 mm expuestos.

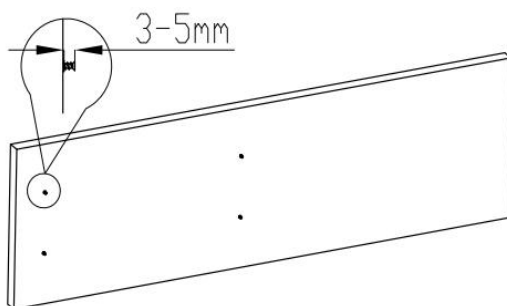

**PASO 5:** Cuelgue el tablero perforado en los tornillos autorroscantes, como se muestra en la imagen.

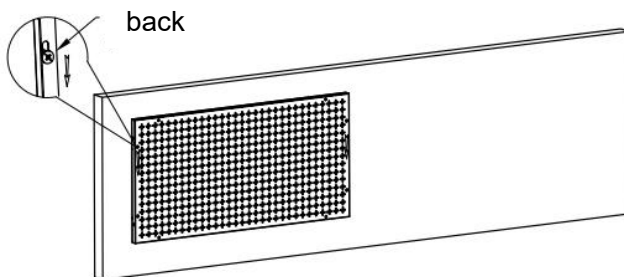

**PASO 6:** Asegúrese de que los cuatro tornillos autorroscantes estén colgados en los orificios de montaje del tablero perforado y apriete los tornillos autorroscantes.



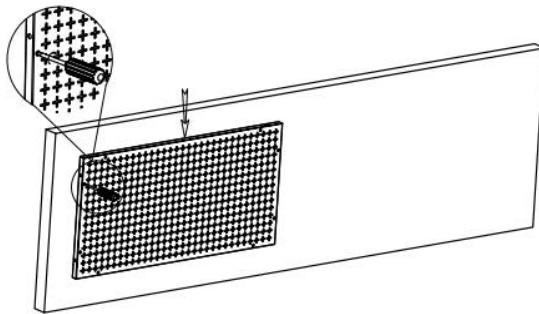

**PASO 7:** Siga los pasos anteriores para instalar otros tableros perforados. (Nota: El tablero perforado se coloca horizontal y verticalmente, y el método de instalación es el mismo).

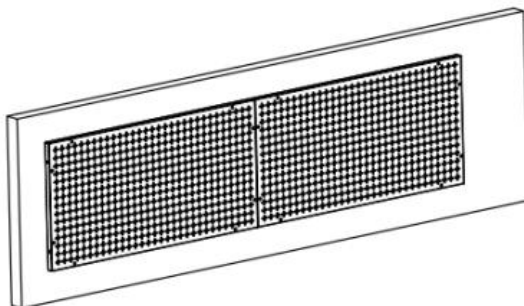

### **Para instalación de postes de madera en la pared**

**PASO 1 :** Alinee el borde del tablero perforado con la línea central del poste y marque los orificios con un clavo fino o un lápiz. (Nota: dos orificios a la izquierda, dos orificios a la derecha)

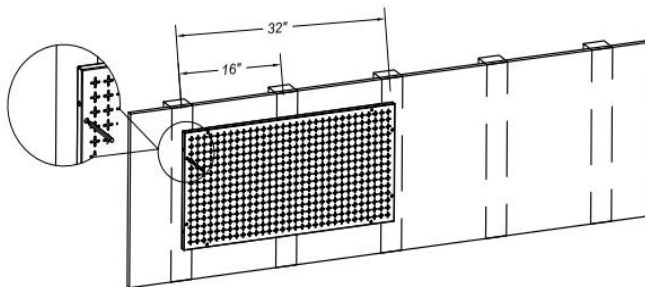

**PASO 2: Taladre agujeros de 3 mm de diámetro y 40 mm de profundidad en los lugares marcados, atornille el tornillo autorroscante en los agujeros, dejando 3~5 mm expuestos. (Nota: Prepare sus propias herramientas ).**

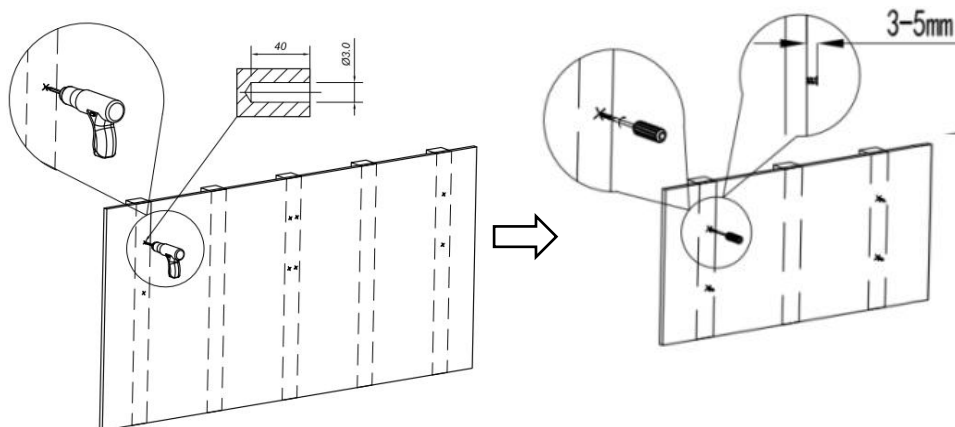

**PASO 3 : Cuelgue el tablero perforado en los tornillos autorroscantes , como se muestra en la imagen.**

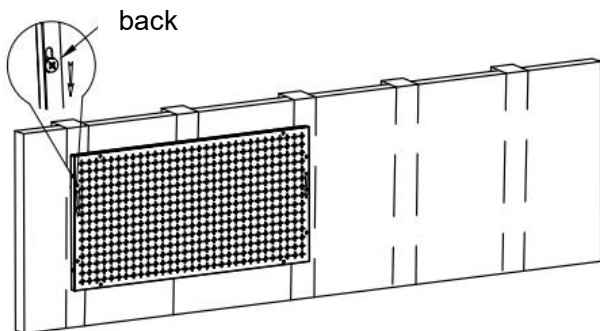

**PASO 4 :** Asegúrese de que los cuatro tornillos autorroscantes estén colgados en los orificios de montaje del tablero perforado y apriete los tornillos autorroscantes .

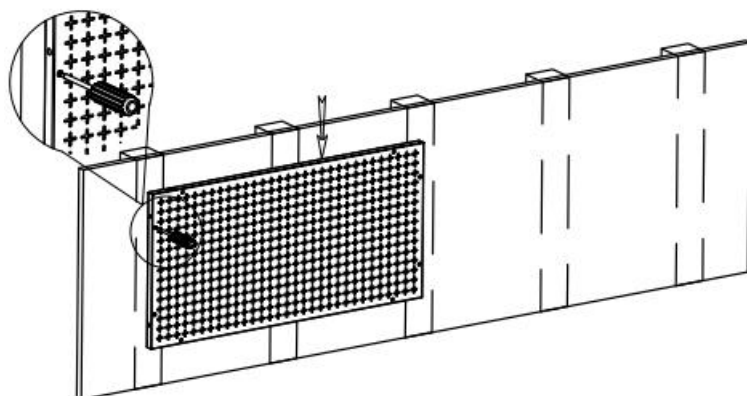

**PASO 5 :** Siga los pasos anteriores para instalar otros tableros perforados. (Nota: El tablero perforado se coloca horizontal y verticalmente, y el método de instalación es el mismo).

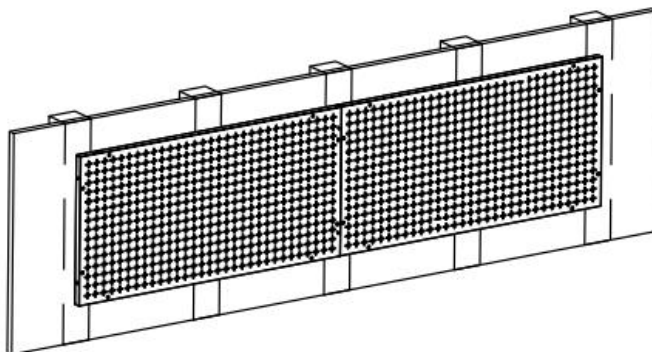

### **Para Bloque de montaje + Instalación de pared de hormigón**

**PASO 1:** Coloque el cartón de posicionamiento sobre la pared a instalar, taladre los orificios de marcado de acuerdo con los orificios marcados en el cartón de posicionamiento.

Retire el cartón y taladre agujeros de 8 mm de diámetro y 40 mm de profundidad en los agujeros marcados. (Nota: Prepare sus propias herramientas de perforación ).

Clave los tacos de expansión completamente en el orificio.

Vertical: A=406 mm

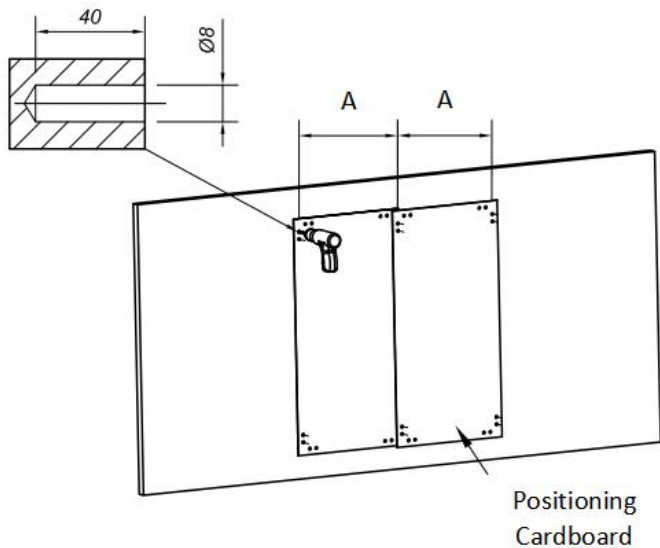

Horizontal: B=814 mm

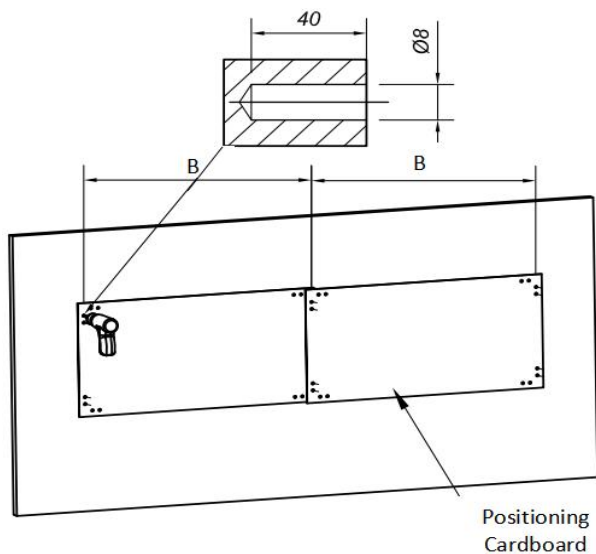

**PASO 2:** Fije el bloque de montaje con tornillos autorroscantes como se muestra ( vertical ) .

Nota: El método de instalación horizontal y vertical es el mismo.

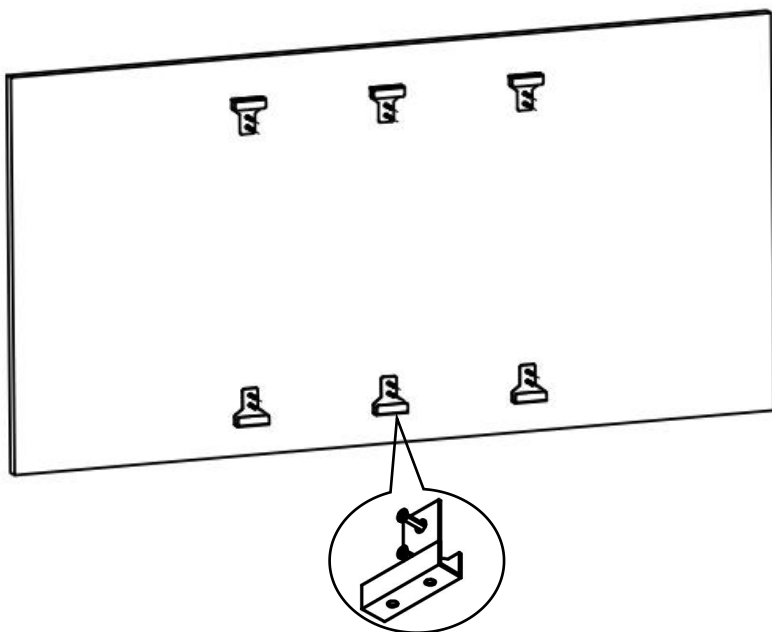

**PASO 3 :** Inserte la placa colgante en el bloque de montaje y conecte el tapón de límite como se muestra .

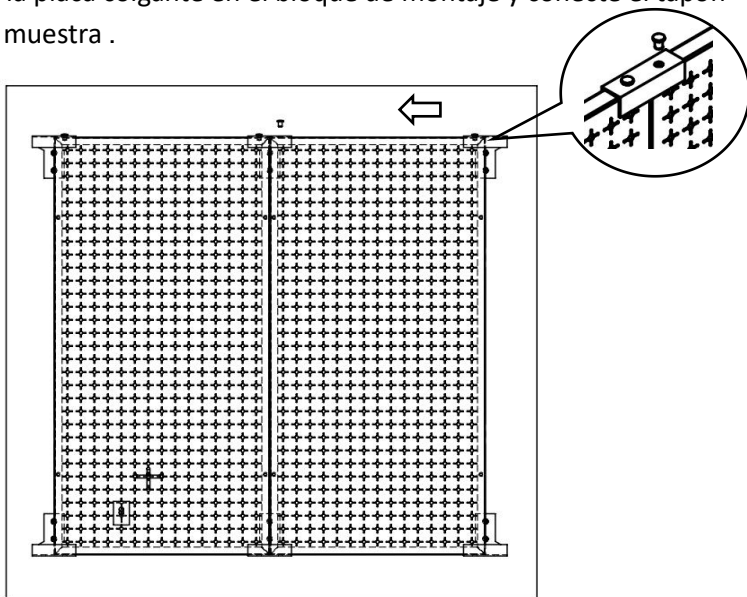

**PASO 4:** Siga los pasos anteriores para instalar otros tableros perforados .

Una vez finalizada la instalación, podrás colgar tus artículos .

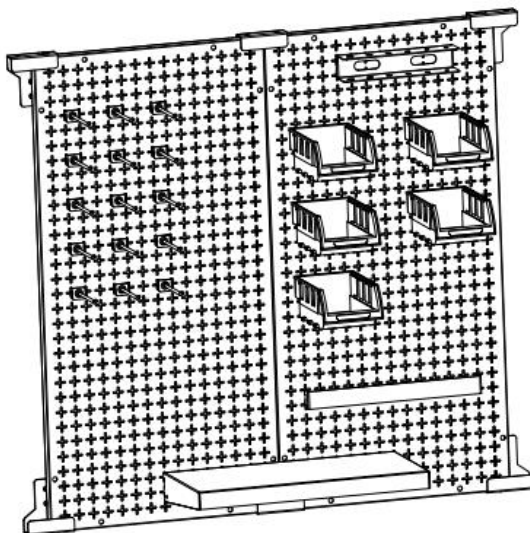

### **Para Instalación de bloque de montaje + poste de pared de madera**

**PASO 1** : Coloque el cartón de posicionamiento en la pared donde se va a instalar, y el centro del orificio en el cartón debe ubicarse en la línea central del poste.

Perfore los agujeros de marcado de acuerdo con los agujeros marcados en el cartón de posicionamiento.

Retire el cartón y taladre agujeros de 3 mm de diámetro y 40 mm de profundidad en los agujeros marcados. (Nota: Prepare sus propias herramientas de perforación ).

Vertical: A=406 mm

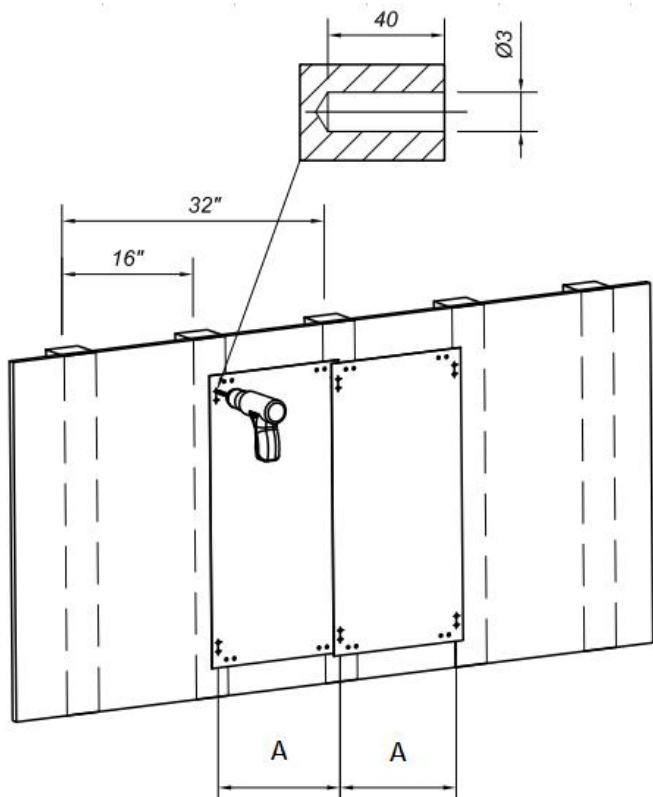

Horizontal : B=814 mm



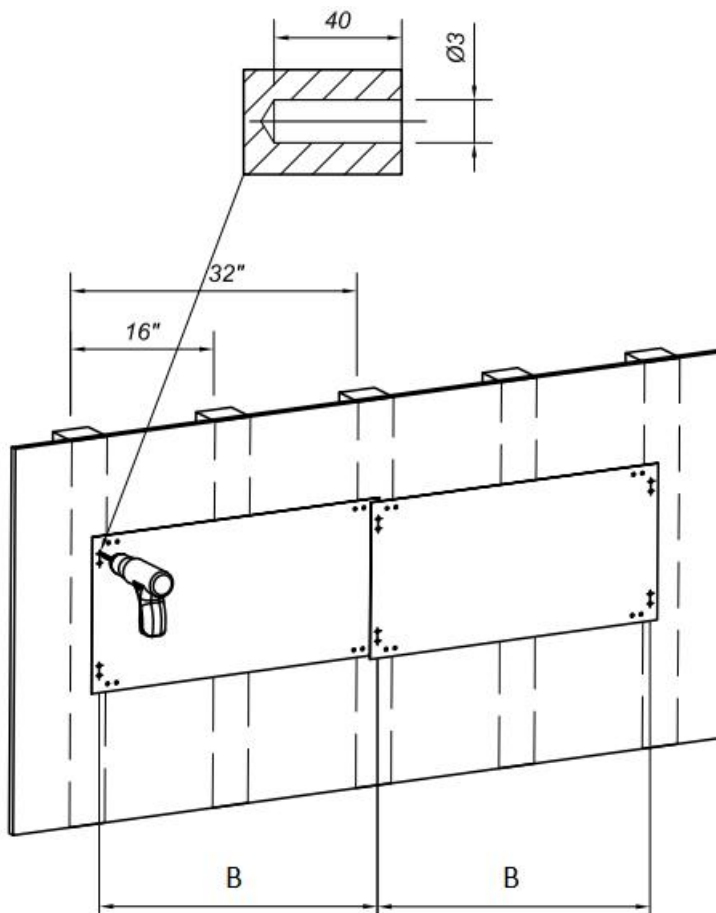

**PASO 2 :** Fije el bloque de montaje con tornillos autorroscantes como se muestra ( vertical ) .

Nota: El método de instalación horizontal y vertical es el mismo.

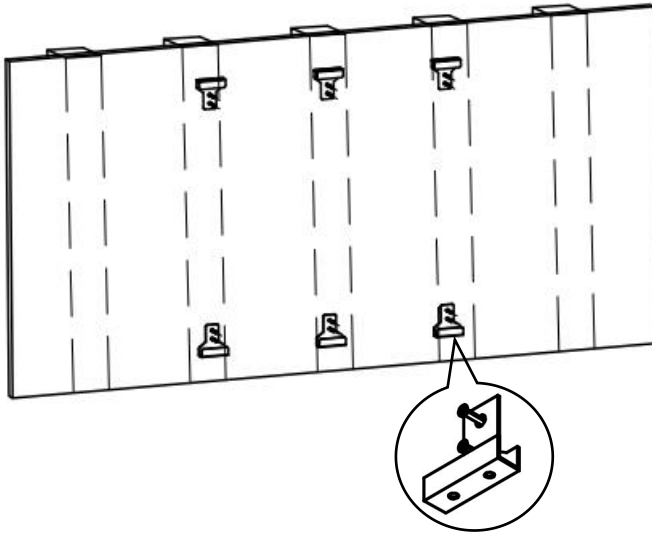

**PASO 3 :** Inserte la placa colgante en el bloque de montaje y conecte el tapón de límite como se muestra .

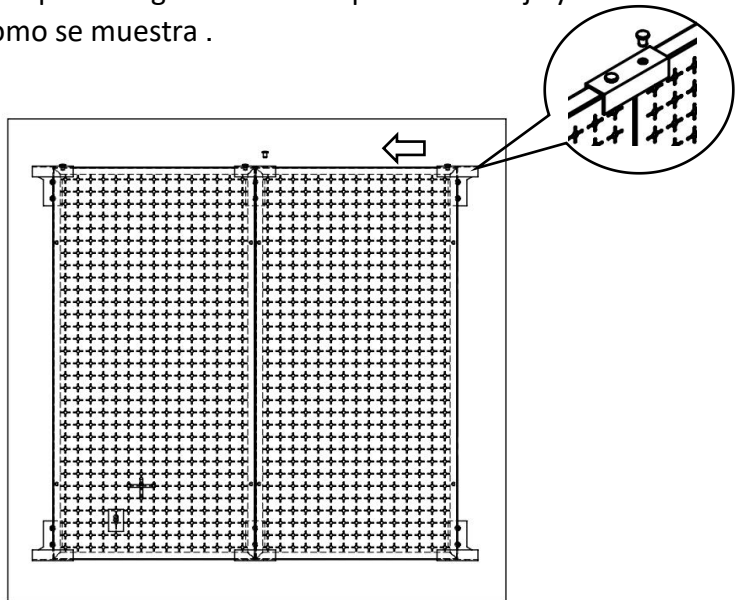

**PASO 4:** Siga los pasos anteriores para instalar otros tableros perforados .

Una vez finalizada la instalación, podrás colgar tus artículos .

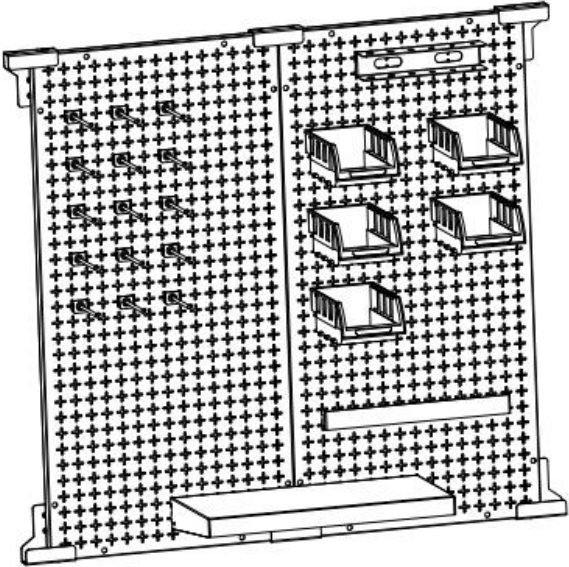

Conjunto de caja de almacenamiento:

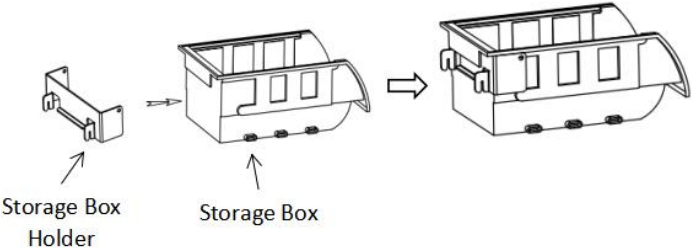

## MAINTENANCE

- No exceda el peso capacidad .
- Después de su uso, limpie y seque el producto en un lugar seco y ventilado.

**Fabricante:** Shanghaimuxinmuyeyouxiangongsi

**Dirección:** Shuangchenglu 803nong11hao1602A-1609shi, baoshanqu, shanghai 200000 CN.

**Importado a AUS:** SIHAO PTY LTD, 1 ROKEVA STREET EASTWOOD NSW 2122 Australia

**Importado a EE. UU.:** Sanven Technology Ltd., Suite 250, 9166 Anaheim Place, Rancho Cucamonga, CA 91730

<b>EC</b>	<b>REP</b>
-----------	------------

E-CrossStu GmbH  
Mainzer Landstr.69, 60329 Frankfurt am Main.

<b>UK</b>	<b>REP</b>
-----------	------------

YH CONSULTING LIMITED.  
C/O YH Consulting Limited Office 147, Centurion House,  
London Road, Staines-upon-Thames, Surrey, TW18 4AX



**VEVOR**<sup>®</sup>

**TOUGH TOOLS, HALF PRICE**

**Técnico Certificado de soporte y garantía electrónica**

**[www.vevor.com/support](http://www.vevor.com/support)**

# **VEVOR<sup>®</sup>**

## **TOUGH TOOLS, HALF PRICE**

Tecnico Supporto e certificato di garanzia elettronica [www.vevor.com/support](http://www.vevor.com/support)

### **PANNELLO FORATO**

### **MANUALE D'USO**

We continue to be committed to provide you tools with competitive price.

"Save Half", "Half Price" or any other similar expressions used by us only represents an estimate of savings you might benefit from buying certain tools with us compared to the major top brands and does not necessarily mean to cover all categories of tools offered by us. You are kindly reminded to verify carefully when you are placing an order with us if you are actually saving half in comparison with the top major brands.

# VEVOR®

TOUGH TOOLS, HALF PRICE

## PEGBOARD

MODELLO:HB641601 ,HB641602,HB9632

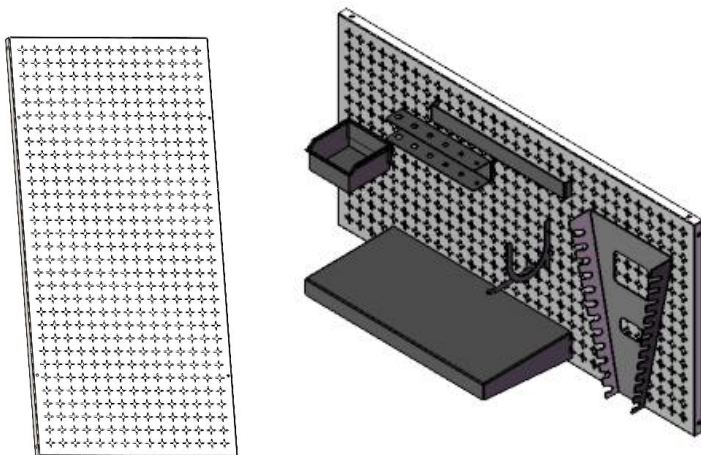

### NEED HELP? CONTACT US!

Have product questions? Need technical support? Please feel free to contact us:

**Technical Support and E-Warranty Certificate**  
[www.vevor.com/support](http://www.vevor.com/support)

This is the original instruction, please read all manual instructions carefully before operating. VEVOR reserves a clear interpretation of our user manual. The appearance of the product shall be subject to the product you received. Please forgive us that we won't inform you again if there are any technology or software updates on our product.



## SAFETY INSTRUCTIONS



### **AVVERTIMENTO:**

1. Leggere questo materiale prima di utilizzare questo prodotto. La mancata osservanza di questa precauzione può causare gravi lesioni.
2. Non superare la capacità di lavoro della forca per pallet .
3. Dopo l'uso, asciugare prima di riporre il prodotto per evitare che si arrugginisca .
4. Le procedure non specificatamente spiegate nel presente manuale devono essere eseguite esclusivamente da un tecnico qualificato.

### **Per evitare gravi lesioni dovute a guasti dell'utensile, non utilizzarlo se danneggiato :**

Il pannello forato deve essere montato su una parete solida.

I pannelli forati non devono essere installati su pareti di legno troppo sottili.

I pannelli forati non devono essere installati su pareti in legno marce o allentate.

Il peso degli oggetti da appendere non deve superare il carico del pannello forato.

Quando si sostituisce il gancio, è necessario selezionarne uno adatto alle dimensioni del pannello forato.

Evitare punte affilate, lame e altri oggetti che possano graffiare il prodotto



### **ATTENZIONE:**

**Leggere attentamente le istruzioni e le procedure per operare in sicurezza.**

**Salva questo manuale**

## MODEL AND PARAMETERS

<b>Model SPEC.</b>	HB641601	HB641602	HB9632
Materiale	Acciaio	Acciaio	Acciaio
Capacità massima di peso (pannello forato singolo)	165 libbre	165 libbre	165 libbre
Dimensioni del pannello forato (L*W)	32 " * 16 "	32 " *16 "	32 " *16 "
Specifiche del foro.	1/4 "	1/4 "	1/4 "
Spessore del foglio	1,0 mm	1,0 mm	1,0 mm
Trattamento superficiale (pannello forato)	Galvanizzazione + verniciatura a polvere	Galvanizzazione + verniciatura a polvere	Galvanizzazione + verniciatura a polvere
Colore	bianco	bianco	bianco

## COMPONENTS

Model Parts	HB641601	HB641602	HB9632
Pannello forato	×2	×2	×3
Gancio	/	×15	×20
Scatola di stoccaggio	/	×5	×5
Supporto per scatola portaoggetti	/	× 5	× 5
Titolare dell'equipaggio S	/	×1	×1
Cremaiera	/	×1	×1
Mensola	/	×1	×2
Blocco di montaggio	/	×6	×8
lo Gancio	/	/	×4
Supporto per chiave inglese	/	/	×1
Spina di limite	/	× 8	×1 2
Spina di espansione	× 8	×1 2	×1 6
Vite autofilettante	× 8	×1 2	×1 6
Posizionamento del cartone	/	× 1	× 1

Manuale dell'utente	x1	x1	x1
------------------------	----	----	----

## INSTALLATION INSTRUCTION

### Preparazione all'installazione:

1. Due o più persone per montare il pannello forato.
2. Si prega di preparare un tappeto o uno zerbino per proteggere il pavimento su cui si desidera disporre tutti gli accessori.
3. Si prega di indossare dei guanti per evitare di graffiarsi con parti taglienti che potrebbero presentarsi durante l'installazione.
4. Si prega di aprire tutte le scatole per verificare che gli accessori siano completi e in buone condizioni .
5. Se per installare questo prodotto è necessario utilizzare utensili elettrici, impostare in anticipo la velocità su bassa.
6. Durante l'installazione , allineare tutti i fori e non stringere prima tutte le viti , altrimenti l'installazione potrebbe risultare difficoltosa.

### Per l'installazione di pareti in calcestruzzo

**FASE 1:** Posizionare la tavola sospesa vicino alla parete installata e segnare i fori con un chiodo sottile o una matita. (Nota: due fori a sinistra, due fori a destra)

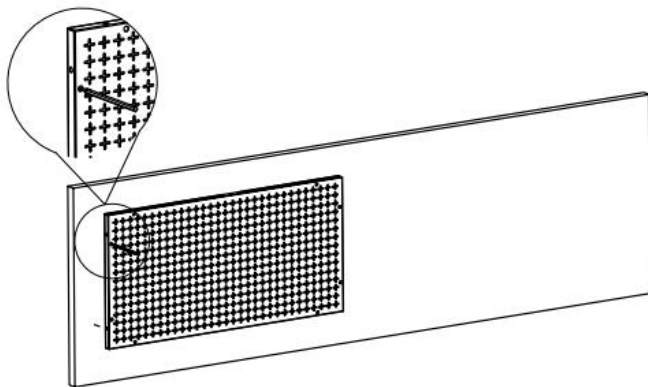

**FASE 2:** Praticare dei fori da 8 mm di diametro e 40 mm di profondità nei punti contrassegnati. (Nota: preparare i propri utensili per la perforazione .)

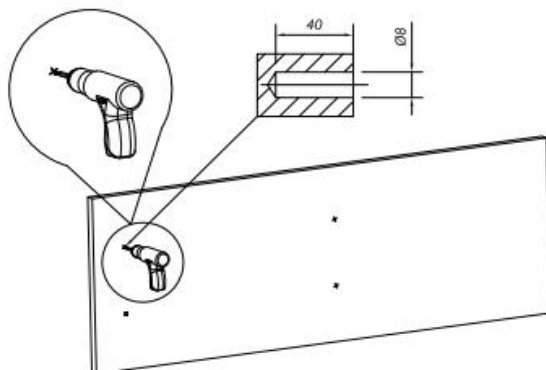

**FASE 3:** Inchiodare completamente i quattro tasselli ad espansione nel foro.

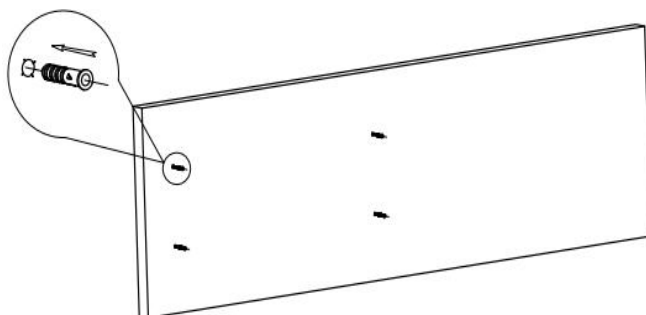

**FASE 4 :** Avvitare la vite autofilettante nel foro del tassello di espansione, lasciando scoperti 3~5 mm.

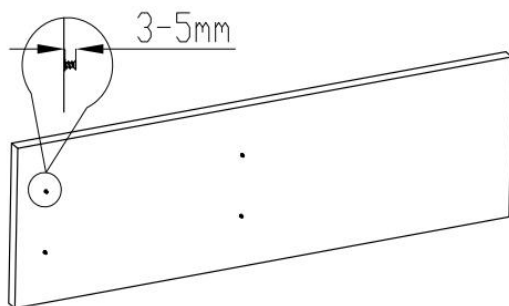

**FASE 5:** Appendere il pannello forato alle viti autofilettanti, come mostrato nell'immagine.

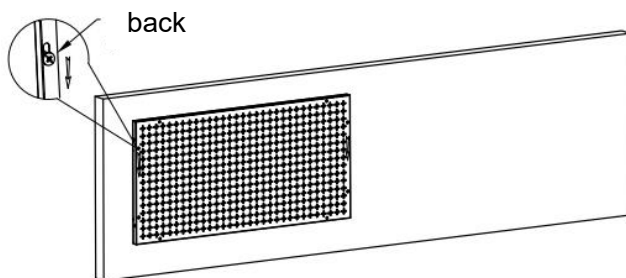

**FASE 6:** Assicurarsi che le quattro viti autofilettanti siano inserite nei fori di montaggio del pannello forato e serrarle.

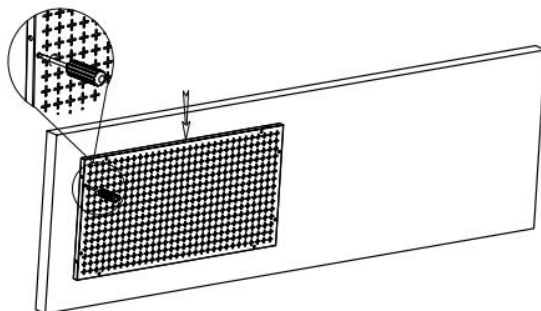

**PASSO 7:** Per installare altri pannelli forati, seguire i passaggi sopra

indicati.

(Nota: il pannello forato viene posizionato orizzontalmente e verticalmente e il metodo di installazione è lo stesso.)

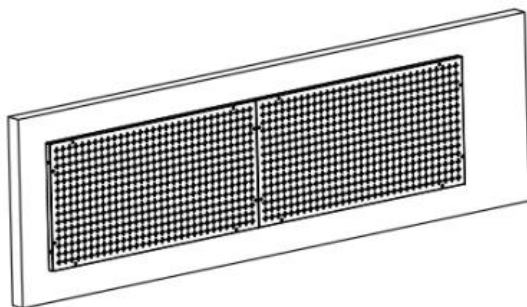

### Per l'installazione di pali in legno

**FASE 1 :** Allineare il bordo del pannello forato con la linea centrale del palo e segnare i fori con un chiodo sottile o una matita. (Nota: due fori a sinistra, due fori a destra)

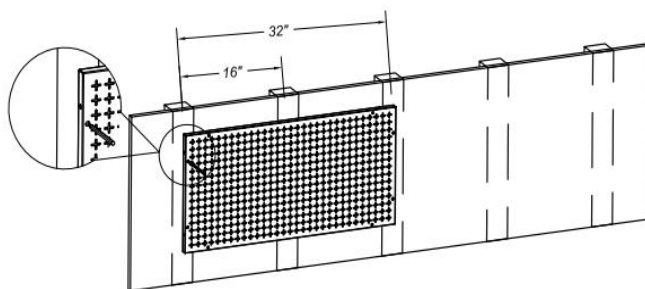

**FASE 2:** Praticare dei fori da 3 mm di diametro e 40 mm di profondità nei punti contrassegnati, avvitare la vite autofilettante nei fori, lasciando scoperti 3~5 mm. (Nota: preparare i propri utensili .)

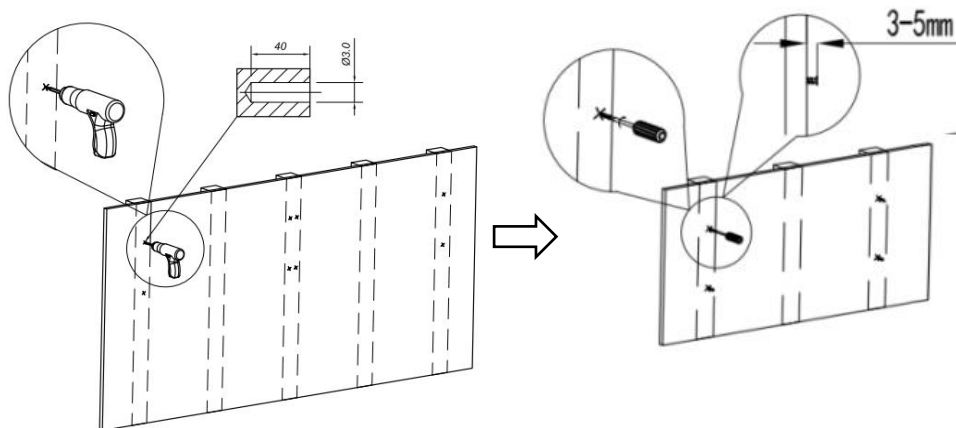

**FASE 3 : Appendere il pannello forato alle viti autofilettanti , come mostrato in figura.**

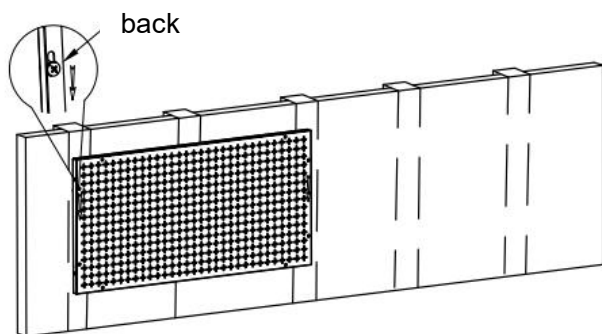

**FASE 4 : Assicurarsi che le quattro viti autofilettanti siano inserite nei fori di montaggio del pannello forato e serrarle .**



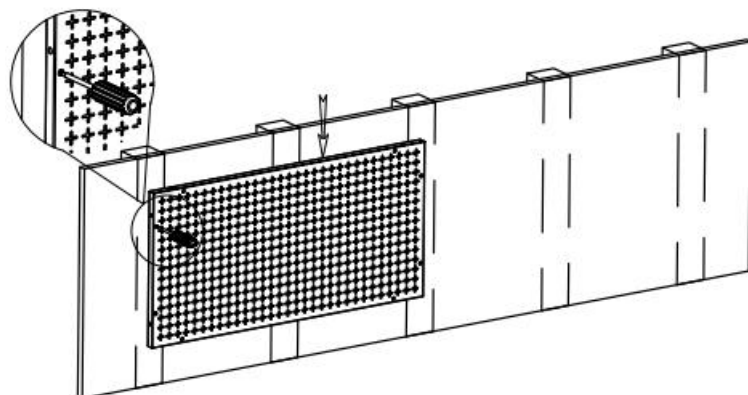

**FASE 5 :** Seguire i passaggi precedenti per installare altri pannelli forati.  
(Nota: il pannello forato viene posizionato orizzontalmente e verticalmente e il metodo di installazione è lo stesso.)

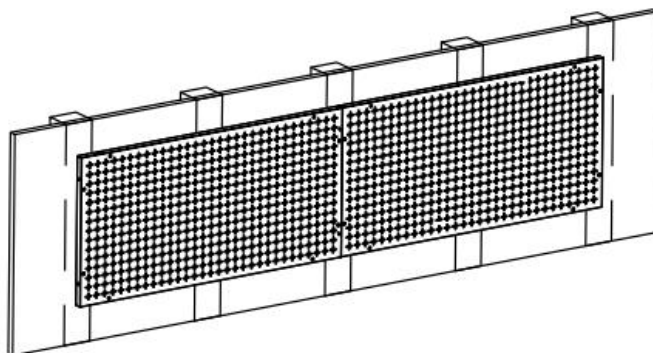

### **Per Blocco di montaggio + installazione di pareti in calcestruzzo**

**PASSO 1:** Appoggiare il cartone di posizionamento sulla parete da installare, praticare i fori di marcatura in corrispondenza dei fori segnati sul cartone di posizionamento.

Togliete il cartone e praticate dei fori di 8 mm di diametro e 40 mm di profondità in corrispondenza dei fori di marcatura. (Nota: preparate i vostri utensili da foratura .)

Inchiodare completamente i tasselli ad espansione nel foro.

Verticale:  $A=406\text{mm}$

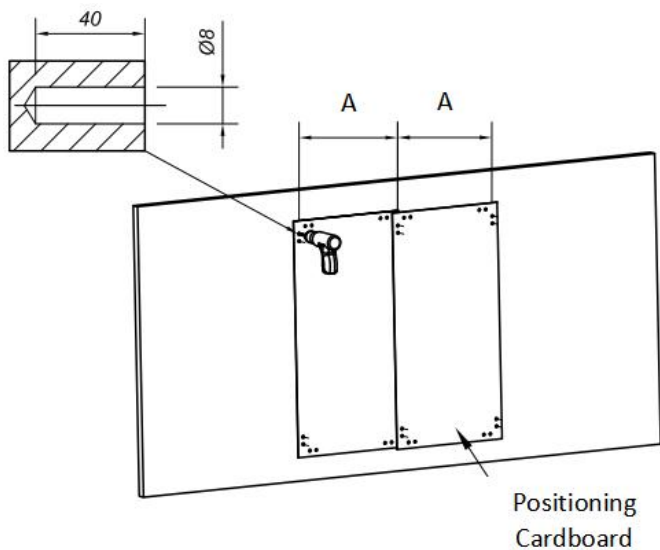

Orizzontale:  $B=814\text{mm}$

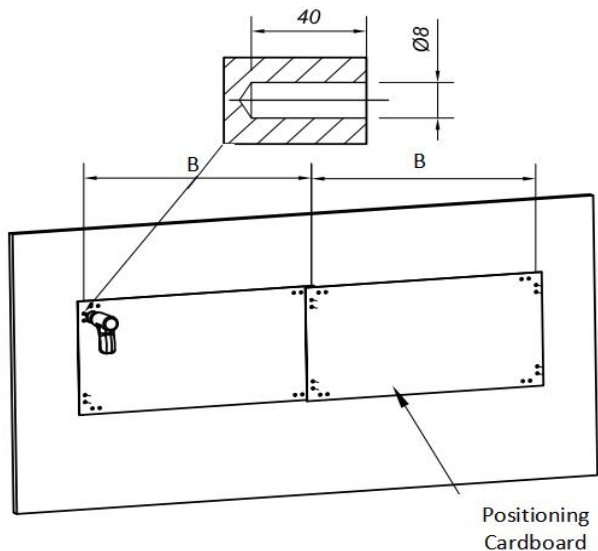

**PASSO 2:** Fissare il blocco di montaggio con viti autofilettanti come mostrato ( verticale ) .

Nota: il metodo di installazione orizzontale e verticale è lo stesso.

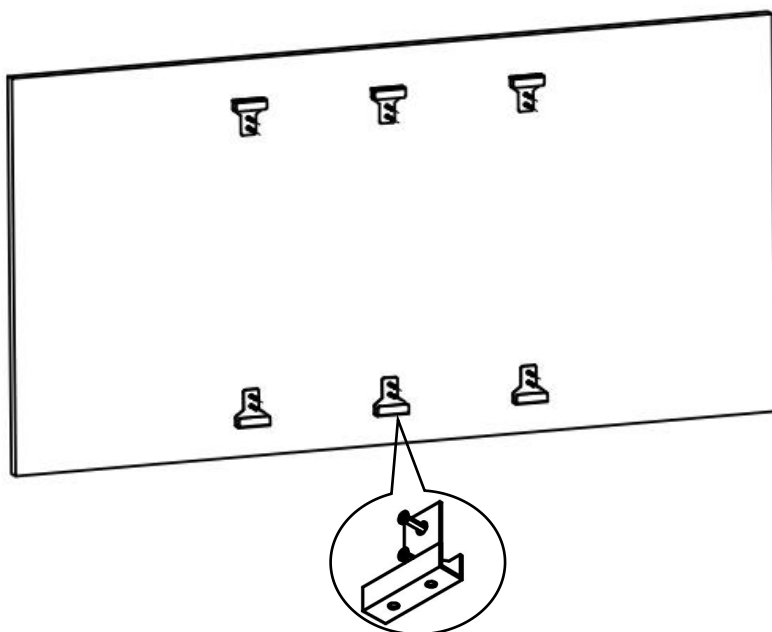

**PASSO 3 :** Inserire la piastra di sospensione nel blocco di montaggio e collegare il tappo di finecorsa come mostrato in figura .

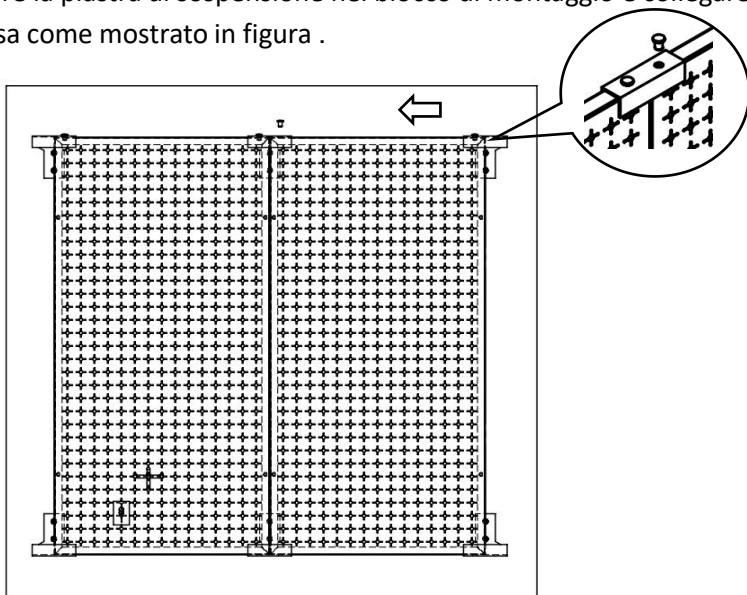

**FASE 4:** Seguire i passaggi sopra indicati per installare altri pannelli forati .

Una volta completata l'installazione, puoi appendere i tuoi oggetti .

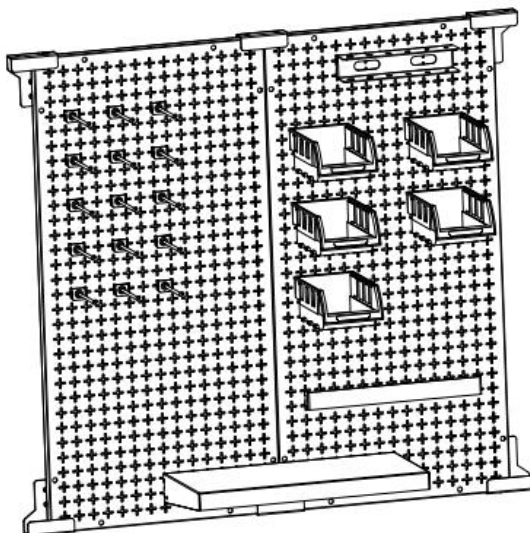

## Per Installazione del blocco di montaggio + palo della parete in legno

**FASE 1** : Posizionare il cartone di posizionamento sulla parete da installare; il centro del foro sul cartone si trova sulla linea centrale del palo. Praticare i fori di marcatura in base ai fori segnati sul cartone di posizionamento.

Togliete il cartone e praticate dei fori di 3 mm di diametro e 40 mm di profondità in corrispondenza dei fori di marcatura. (Nota: preparate i vostri utensili da foratura .)

Verticale: A=406mm

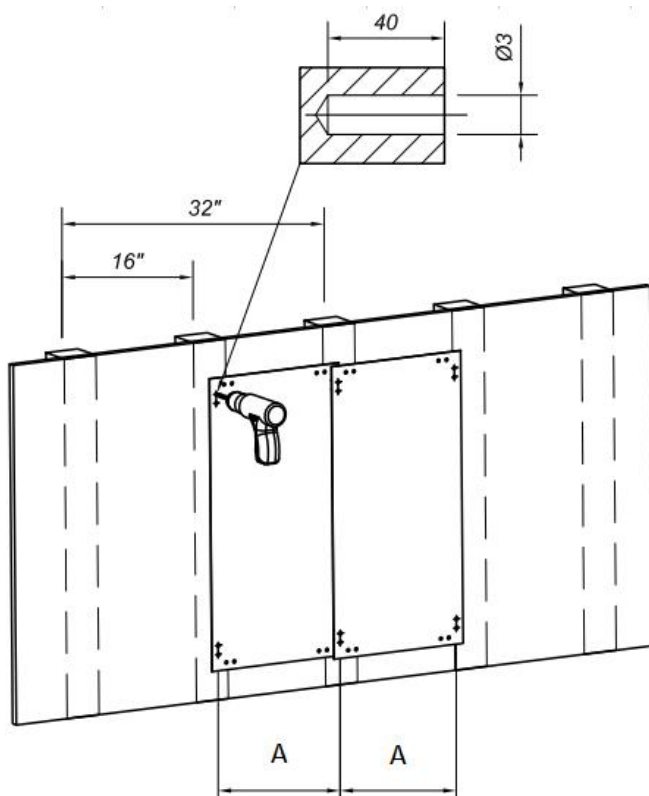

Orizzontale : B=814mm

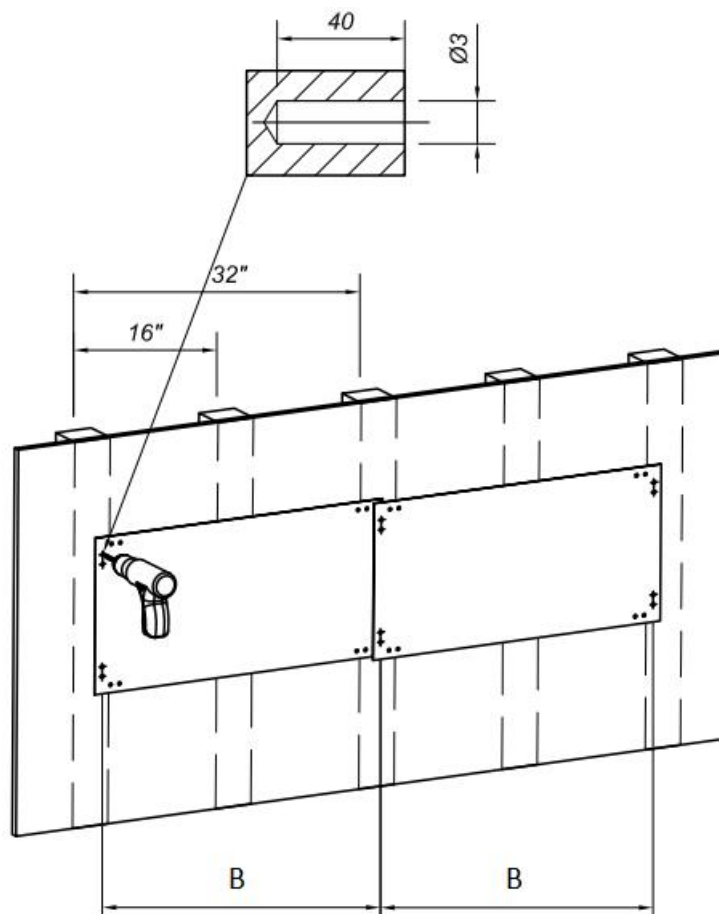

**PASSO 2** : Fissare il blocco di montaggio con viti autofilettanti come mostrato ( verticale ) .

Nota: il metodo di installazione orizzontale e verticale è lo stesso.

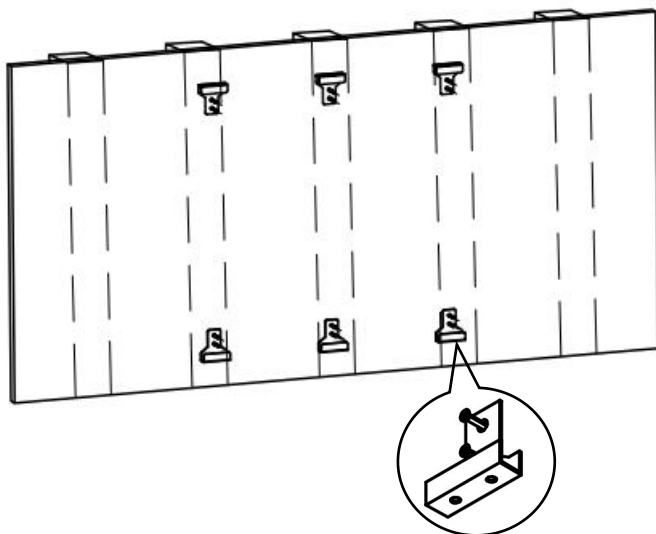

**PASSO 3** : Inserire la piastra di sospensione nel blocco di montaggio e collegare il tappo di finecorsa come mostrato in figura .

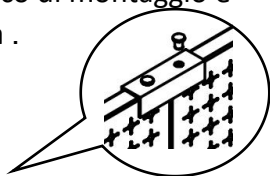

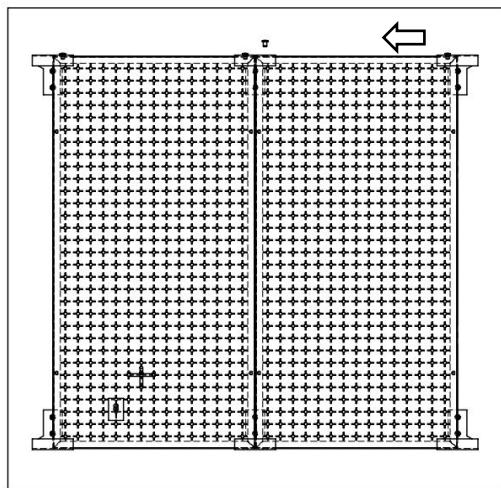

**FASE 4:** Seguire i passaggi sopra indicati per installare altri pannelli forati .

Una volta completata l'installazione, puoi appendere i tuoi oggetti .

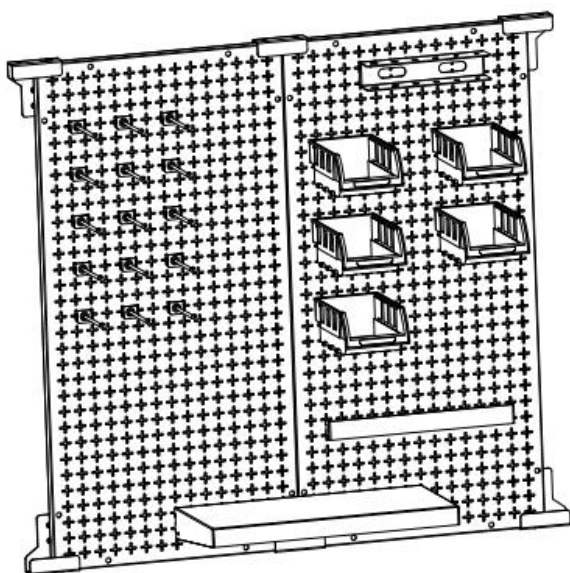



Montaggio della scatola di immagazzinaggio:

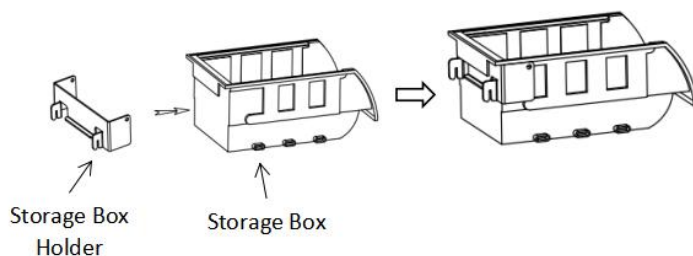

## MAINTENANCE

- Non superare il peso capacità .
- Dopo l'uso, pulire e asciugare il prodotto in un luogo asciutto e ventilato.

**Produttore:** Shanghai muxinmuyeyouxiangongsi

**Indirizzo:** Shuangchenglu 803nong11hao1602A-1609shi, baoshanqu, shanghai 200000 CN.

**Importato in AUS:** SIHAO PTY LTD, 1 ROKEVA STREET EASTWOOD NSW 2122 Australia

**Importato negli USA:** Sanven Technology Ltd., Suite 250, 9166 Anaheim Place, Rancho Cucamonga, CA 91730

<b>EC</b>	<b>REP</b>
-----------	------------

E-CrossStu GmbH  
Mainzer Landstr.69, 60329 Frankfurt am Main.

<b>UK</b>	<b>REP</b>
-----------	------------

YH CONSULTING LIMITED.  
C/O YH Consulting Limited Office 147, Centurion House,  
London Road, Staines-upon-Thames, Surrey, TW18 4AX



**VEVOR**<sup>®</sup>

**TOUGH TOOLS, HALF PRICE**

**Tecnico Supporto e certificato di garanzia elettronica**

**[www.vevor.com/support](http://www.vevor.com/support)**