

# **VEVOR<sup>®</sup>**

**TOUGH TOOLS, HALF PRICE**

Technical Support and E-Warranty Certificate

[www.vevor.com/support](http://www.vevor.com/support)

## **POWER TOOL ORGANIZER USER MANUAL**

We continue to be committed to provide you tools with competitive price.

"Save Half", "Half Price" or any other similar expressions used by us only represents an estimate of savings you might benefit from buying certain tools with us compared to the major top brands and does not necessarily mean to cover all categories of tools offered by us. You are kindly reminded to verify carefully when you are placing an order with us if you are actually saving half in comparison with the top major brands.

# VEVOR<sup>®</sup>

TOUGH TOOLS, HALF PRICE

## POWER TOOL ORGANIZER

Model: JC-PTO-001; JC-PTO-002; JC-PTO-003; JC-PTO-004; JC-PTO-005

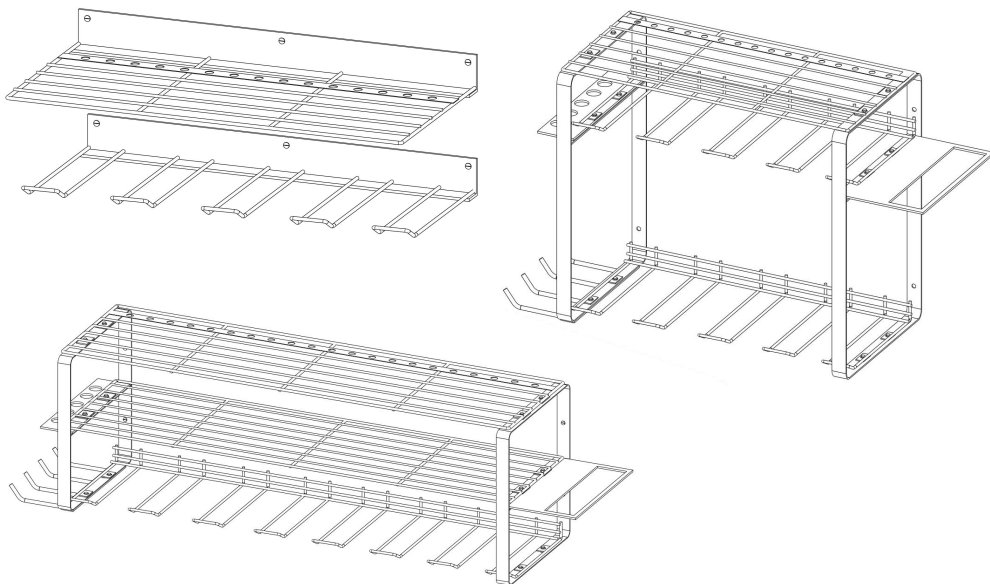

### NEED HELP? CONTACT US!

Have product questions? Need technical support? Please feel free to contact us:

**Technical Support and E-Warranty Certificate**  
[www.vevor.com/support](http://www.vevor.com/support)

This is the original instruction, please read all manual instructions carefully before operating. VEVOR reserves a clear interpretation of our user manual. The appearance of the product shall be subject to the product you received. Please forgive us that we won't inform you again if there are any technology or software updates on our product.

## **1. ⚠️WARNING!**

1. Before installation, make sure it does not run the risk of piercing any hidden current cables or water pipes. In case of doubt, use a digital tracking device or consult an expert.
2. The rail should be mounted on a stable surface. Do not overload.
3. The installation of the wall mount should be done by an adult, and children should not use it without supervision.
4. Recommended for brick and concrete only; use special hardware for installing it to plasterboard or other substrates.
5. Before installing and using a power tool organizer, be sure to read and understand all safety warnings and instructions.
6. Please ensure that the power tool organizer is installed on a stable wall to prevent the power tool organizer and tools from falling.
7. Please do not exceed the maximum load capacity of the power tool organizer to prevent damage to the power tool organizer and tools from falling.
8. Please periodically check the stability of the tool holder and the safety of the tools.

## **2. Maintenance Guide**

1. Clean the tool organizer regularly to avoid the accumulation of dust and grime.
2. Check the stability of the power tool organizer to make sure all mounting hardware is secure and undamaged.
3. Check the load of the power tool organizer to ensure that the maximum load capacity is not exceeded.

### 3. Product Description

The power tool organizer is a power tool organizer specially designed for storing small cordless metal cutting and assembly power tools (electric drills, impact drills, electric reciprocating saws, electric screwdrivers, electric wrenches, etc.). Power tools can be hung on the bottom slot (upright or upside down), and the flat layer can store batteries, small tool boxes (with different types of drill bits, etc.), and slightly larger tools (such as angle grinders and electric cutters). The product is mainly used in garages, workshops, and tool rooms; the screwdriver storage hole is used to place small manual tools such as screwdrivers and pliers.

### 4. Product Parameter

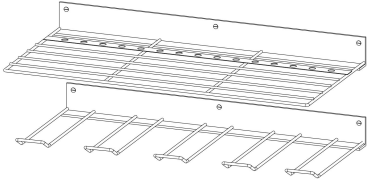
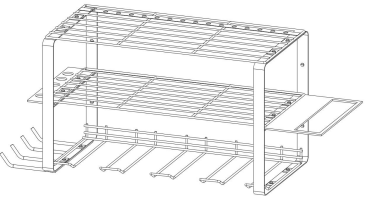
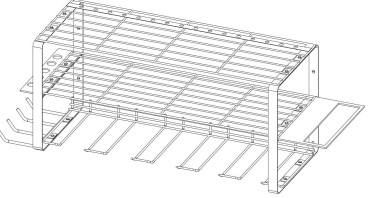

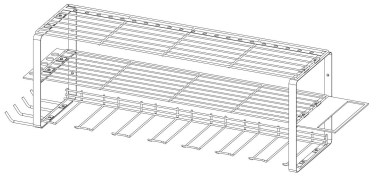
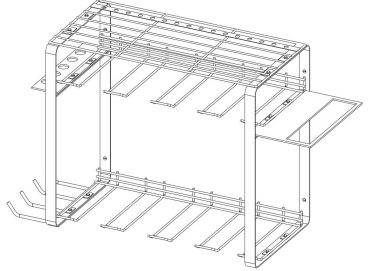

item	Model	Picture	Layers	Grooves	N.W	G.W	Packaging Size
SKU 1	JC-PTO-001		2	4	3.0kg	3.3kg	445*220*86mm
SKU 2	JC-PTO-002		3	4	2.3kg	2.7kg	430*227*83mm
SKU 3	JC-PTO-003		3	5	2.5kg	3.0kg	505*227*85mm

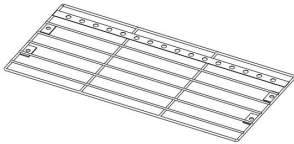
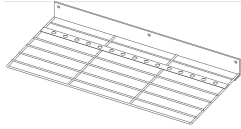
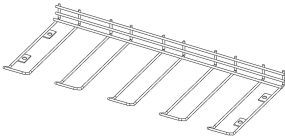
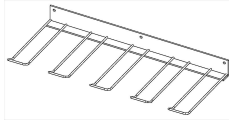
SKU 4	JC-PTO-004		3	7	3.0kg	3.5kg	655*225*80mm
SKU 5	JC-PTO-005		3	8	2.8kg	3.2kg	435*237*115mm

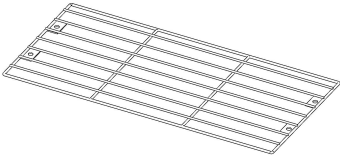
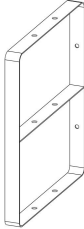
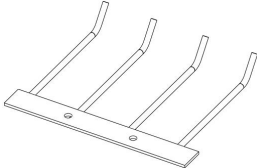
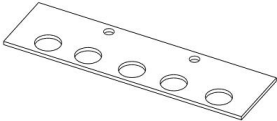
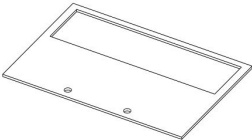
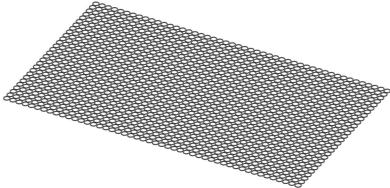
## 5. Part list

item	Parts		SKU	SKU	SKU	SKU	SKU
			1	2	3	4	5
			JC-PTO-001	JC-PTO-002	JC-PTO-003	JC-PTO-004	JC-PTO-005
A	Tool panel 	2pcs 	1pcs	1pcs	1pcs	1pcs	1pcs
B	Groove panel 	2pcs (4 Grooves) 	1pcs (4 Grooves)	1pcs (5 Grooves)	1pcs (7 Grooves)	2pcs (4 Grooves)	

C	<p style="text-align: center;">Mid panel</p> 	/	1pcs	1pcs	1pcs	/
D	<p style="text-align: center;">Bracket</p> 	/	2pcs	2pcs	2pcs	2pcs
E	<p style="text-align: center;">Long hook</p> 	/	1pcs	1pcs	1pcs	1pcs
F	<p style="text-align: center;">Pliers holder</p> 	/	1pcs	1pcs	1pcs	1pcs
G	<p style="text-align: center;">Hammer holder</p> 	/	1pcs	1pcs	1pcs	1pcs
H	<p style="text-align: center;">Anti-slip mat</p> 	2pcs	1pcs	1pcs	1pcs	1pcs

I	<p>Nut</p> 	/	12 pcs	12 pcs	12 pcs	12 pcs
J	<p>Screw</p> 	/	12 pcs	12 pcs	12 pcs	12 pcs
K	<p>Self tapping screw</p> 	12pcs	4pcs	4pcs	4pcs	4pcs
L	<p>Dowels</p> 	12pcs	4pcs	4pcs	4pcs	4pcs
M	<p>Wrench</p> 	/	1pcs	1pcs	1pcs	1pcs

## 6. Installation Guide for SKU1

Step 1. Use Part K (Self-tapping screw) and Part L (Dowels) to fix the top and lower panels to the wall, and the height can be randomly defined.

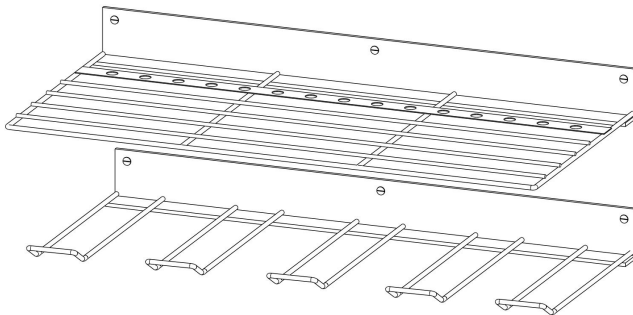

Part A and Part B

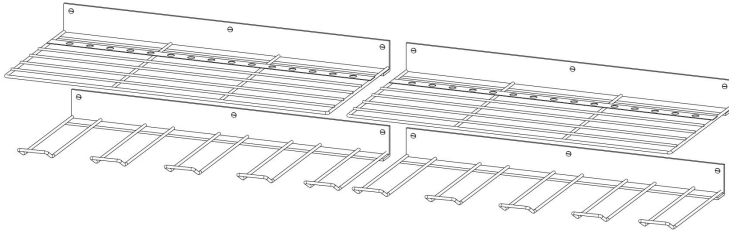

Part A and Part B

Step 2. Place part H(Anti-slip mat) on top of part A.

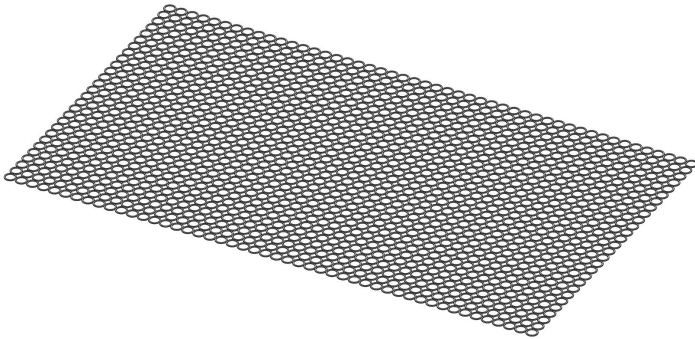

## 7. Installation Guide for SKU2 ~ SKU4

Step 1. As shown in the picture, locate Part D (Bracket) and place Part B (Groove panel) and Part E (long hook) between the two side panels. Use the tool Part M (wrench) along with the fasteners Part J (Screw) and Part I (Nut) to securely fasten Part B and Part E onto Part D.

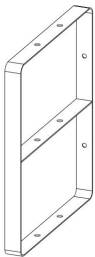

Part D

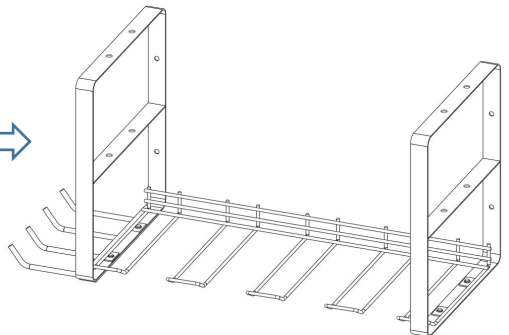
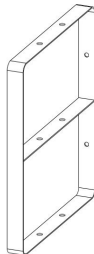

Install Part B and Part E



Step 2. Place Part G (Hammer holder), Part F (Pliers holder), and Part C (Mid panel) in the middle layer of t Part D (Bracket), Use the tool Part M (wrench) along with the fasteners Part J (Screw) and Part I (Nut) to securely fasten them in place.

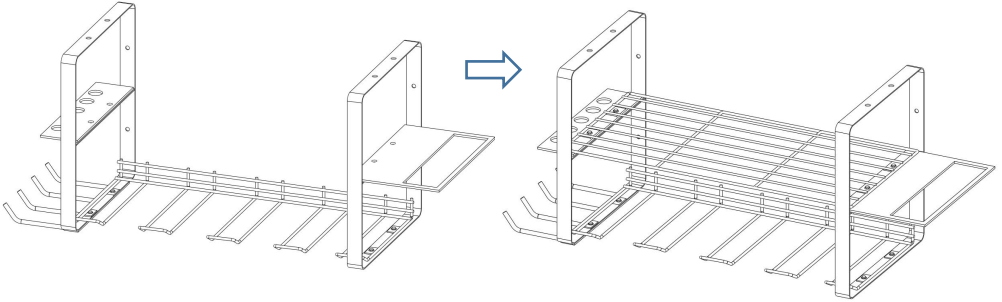

Install Part G and Part F

Install Part C

Step 3: Install Part A (Tool panel). Use the tool Part M (wrench) along with the fasteners Part J (Screw) and Part I (Nut) to securely fasten it in place.

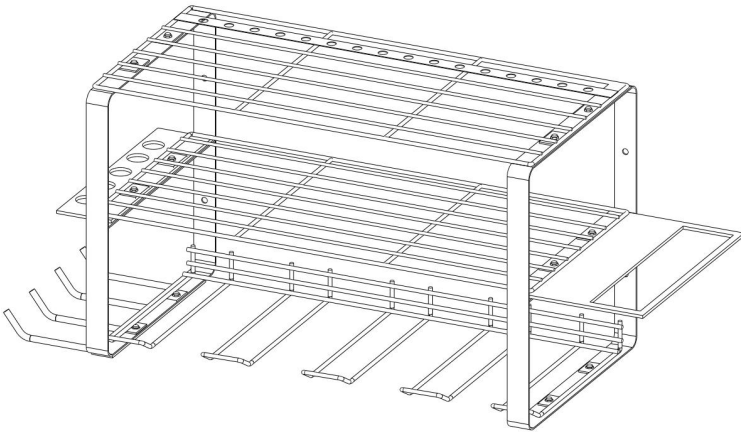

Install Part A

Note: Below is the appearance of SKU2, SKU3, and SKU4 after installing the tool panel.

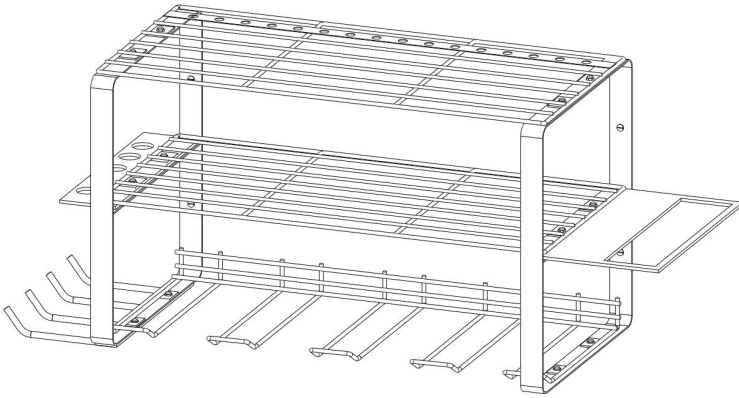

SKU2

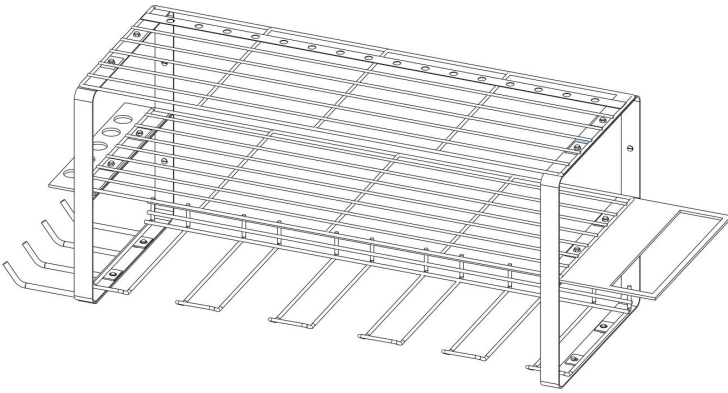

SKU3

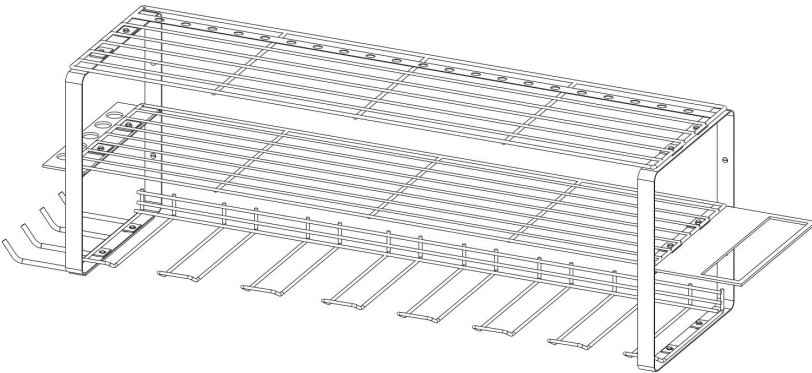

SKU4

Step 4: Use Part K (Self-tapping screw) and Part L (Dowels) to securely fasten the power tool organizer in the desired location on the wall.

Step 5: Place Part H (Anti-slip mat) on top of Part A. The installation process is complete.

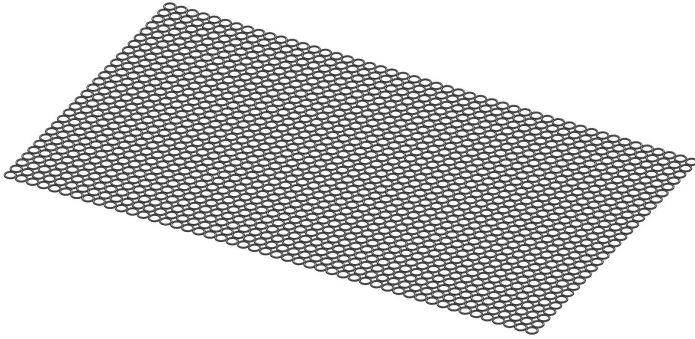

## 8. Installation Guide for SKU5

Step 1. As shown in the picture, locate Part D (Bracket) and place Part B (Groove panel) and Part E (long hook) between the two side panels. Use the tool Part M (wrench) along with the fasteners Part J (Screw) and Part I (Nut) to securely fasten Part B and Part E onto Part D.

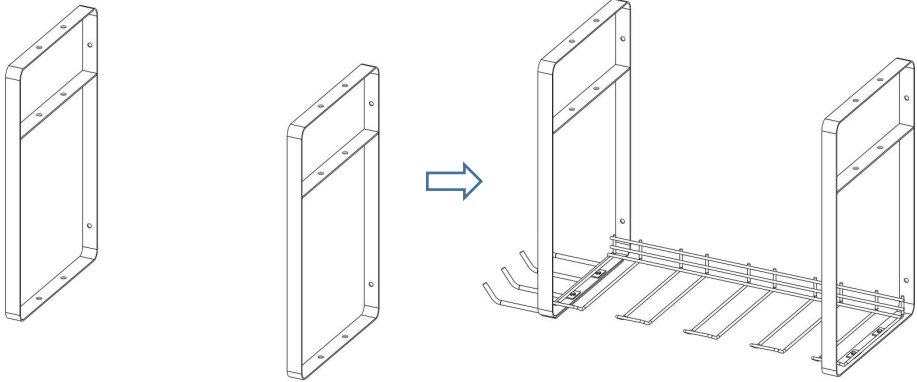

Find Part D

Install Part B and Part E

Step 2. Place Part G (Hammer holder), Part F (Pliers holder), and Part B (Groove panel) in the middle layer of Part D (Bracket), Use the tool Part M (wrench) along with the fasteners Part J (Screw) and Part I (Nut) to securely fasten them in place.

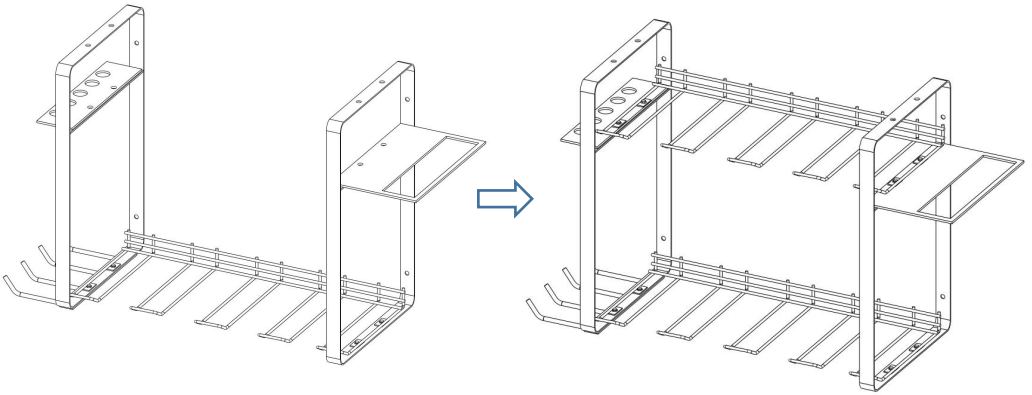

Install Part G and Part F

Install Part B

**Step 3. Install Part A (Tool panel).** Use the tool Part M (wrench) along with the fasteners Part J (Screw) and Part I (Nut) to securely fasten it in place.

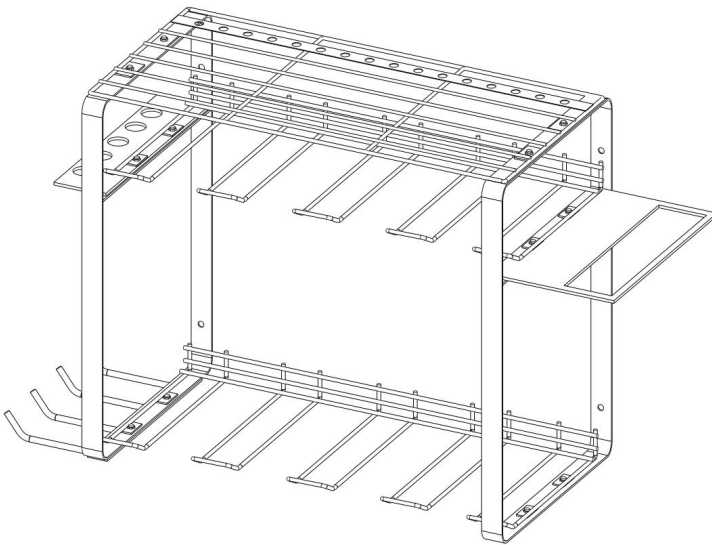

**Step 4: Use Part K (Self-tapping screw) and Part L (Dowels)** to securely fasten the power tool organizer in the desired location on the wall.

Step 5: Place Part H (Anti-slip mat) on top of Part A. The installation process is complete.

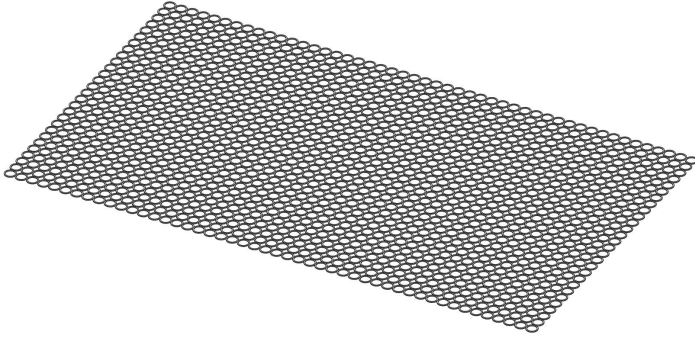

## 9. User Guide

1. Make sure that items hung on the rack do not exceed their weight limit.
2. Try to distribute the weight on the hanger evenly and avoid being too heavy on one side.
3. Do not hang sharp or damaged objects on the hanger, as this may scratch the hanger or cause injury.
4. Adjust the spacing of the hooks as needed to accommodate items of different sizes and shapes.
5. Before loading, the hook needs to be completely placed on the rail.

**Manufacturer:** Shanghaimuxinmuyeyouxiangongsi

**Address:** Shuangchenglu 803nong11hao1602A-1609shi, baoshanqu, shanghai 200000 CN.

**Imported to AUS:** SIHAO PTY LTD, 1 ROKEVA STREETEASTWOOD NSW 2122 Australia

**Imported to USA:** Sanven Technology Ltd., Suite 250, 9166 Anaheim Place, Rancho Cucamonga, CA 91730

<b>EC</b>	<b>REP</b>
-----------	------------

E-CrossStu GmbH  
Mainzer Landstr.69, 60329 Frankfurt am Main.

<b>UK</b>	<b>REP</b>
-----------	------------

YH CONSULTING LIMITED.  
C/O YH Consulting Limited Office 147, Centurion House,  
London Road, Staines-upon-Thames, Surrey, TW18 4AX



**VEVOR<sup>®</sup>**

**TOUGH TOOLS, HALF PRICE**

**Technical Support and E-Warranty Certificate**

**[www.vevor.com/support](http://www.vevor.com/support)**



# **VEVOR<sup>®</sup>**

**TOUGH TOOLS, HALF PRICE**

Technique Certificat d'assistance et de garantie électronique

[www.vevor.com/support](http://www.vevor.com/support)

## **ORGANISATEUR D'OUTILS ÉLECTRIQUES MANUEL D'UTILISATION**

We continue to be committed to provide you tools with competitive price.

"Save Half", "Half Price" or any other similar expressions used by us only represents an estimate of savings you might benefit from buying certain tools with us compared to the major top brands and does not necessarily mean to cover all categories of tools offered by us. You are kindly reminded to verify carefully when you are placing an order with us if you are actually saving half in comparison with the top major brands.



# VEVOR®

TOUGH TOOLS, HALF PRICE

## POWER TOOL ORGANIZER

Modèle : JC-PTO-001 ; JC-PTO-002 ; JC-PTO-003 ; JC-PTO-004 ; JC-PTO-005

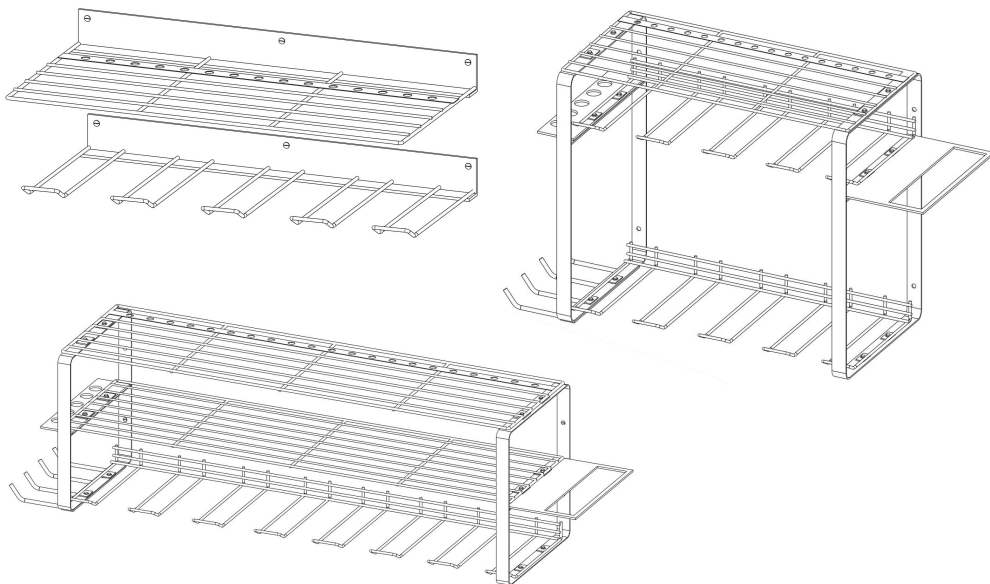

### NEED HELP? CONTACT US!

Have product questions? Need technical support? Please feel free to contact us:

**Technical Support and E-Warranty Certificate**  
**[www.vevor.com/support](http://www.vevor.com/support)**

This is the original instruction, please read all manual instructions carefully before operating. VEVOR reserves a clear interpretation of our user manual. The appearance of the product shall be subject to the product you received. Please forgive us that we won't inform you again if there are any technology or software updates on our product.

## 10. WARNING!

9. Avant l'installation, assurez-vous qu'il ne risque pas de percer des câbles électriques ou des conduites d'eau cachés. En cas de doute, utilisez un dispositif de repérage numérique ou consultez un expert.
10. Le rail doit être monté sur une surface stable. Ne pas surcharger.
11. L'installation du support mural doit être effectuée par un adulte et les enfants ne doivent pas l'utiliser sans surveillance.
12. Recommandé pour la brique et le béton uniquement ; utilisez du matériel spécial pour l'installation sur des plaques de plâtre ou d'autres substrats.
13. Avant d'installer et d'utiliser un organisateur d'outils électriques , assurez-vous de lire et de comprendre tous les avertissements et instructions de sécurité.
14. Assurez-vous que l'organisateur d'outils électriques est installé sur un mur stable pour éviter que l'Organisateur d'outils électriques et outils contre les chutes.
15. Veuillez ne pas dépasser la capacité de charge maximale du organisateur d'outils électriques pour éviter d'endommager le Organisateur d'outils électriques et outils contre les chutes.
16. Veuillez vérifier périodiquement la stabilité du porte-outil et la sécurité des outils .

## 11. Maintenance Guide

4. Nettoyez régulièrement l'organisateur d'outils pour éviter l'accumulation de poussière et de saleté.
5. Vérifiez la stabilité du Organisateur d'outils électriques pour s'assurer

- que tout le matériel de montage est sécurisé et non endommagé.
6. Vérifiez la charge du Organisateur d'outils électriques pour garantir que la capacité de charge maximale ne soit pas dépassée.

## 12. Product Description

L'organisateur d'outils électriques est un organisateur d'outils électriques conçu spécialement pour ranger les petits outils électriques de coupe et d'assemblage de métaux sans fil (perceuses électriques, perceuses à percussion, scies alternatives électriques, tournevis électriques, clés électriques, etc.). Les outils électriques peuvent être suspendus sur la fente inférieure (à la verticale ou à l'envers), et la couche plate peut stocker des batteries, de petites boîtes à outils (avec différents types de forets, etc.) et des outils légèrement plus grands (tels que des meuleuses d'angle et des coupeurs électriques). Le produit est principalement utilisé dans les garages, les ateliers et les salles d'outillage ; le trou de rangement du tournevis est utilisé pour placer de petits outils manuels tels que des tournevis et des pinces.

## 13. Product Parameter

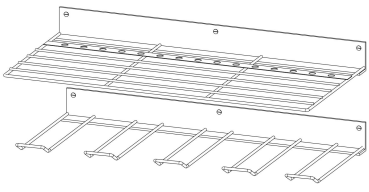
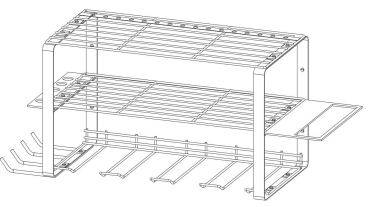
article	Modèle	Image	Couche s	Rainures	Nord-Ouest	GW	Taille de l'emballage
SKU 1	JC-PTO-001		2	4	3,0 kg	3,3 kg	445*220*86mm
SKU 2	JC-PTO-002		3	4	2,3 kg	2,7 kg	430*227*83mm

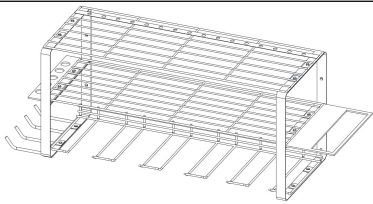
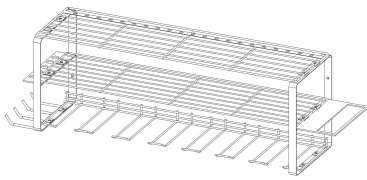
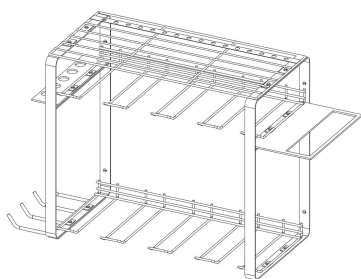



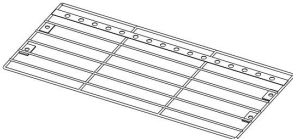
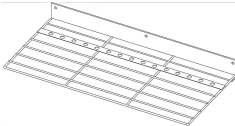

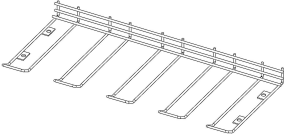
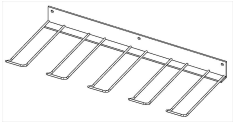
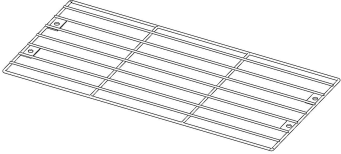
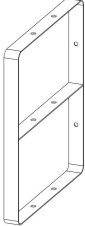
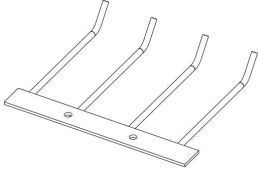
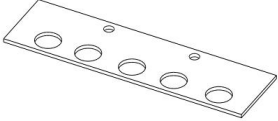
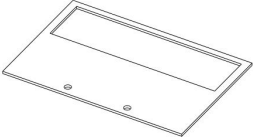
SKU 3	JC- PTO- 003		3	5	2,5 kg	3,0 kg	505*227 *85mm
SKU 4	JC- PTO- 004		3	7	3,0 kg	3,5 kg	655*225 *80mm
SKU 5	JC- PTO- 005		3	8	2,8 kg	3,2 kg	435*237 *115mm

## 14. Part list

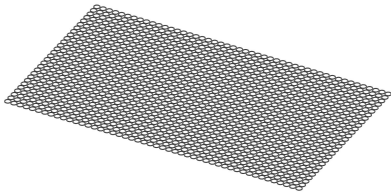
article	Parties		UGS	SKU	SKU	SKU	SKU
			1	2	3	4	5
			JC- PTO- 001	JC- PTO- 002	JC- PTO- 003	JC- PTO- 004	JC- PTO- 005
UN	Panneau d'outils 	2 pièces 		1 pièce	1 pièce	1 pièce	1 pièce

B	<p>Panneau rainuré</p> 	<p>2 pièces (4 rainures)</p> 	1 pièce (4 rainur es)	1 pièce (5 rainur es)	1 pièce (7 rainu res)	2 pièce s (4 rainu res)
C	<p>Panneau central</p> 	/	1 pièce	1 pièce	1 pièce	/
D	<p>Support</p> 	/	2 pièce s	2 pièce s	2 pièce s	2 pièce s
E	<p>Crochet long</p> 	/	1 pièce	1 pièce	1 pièce	1 pièce
F	<p>Porte-pince</p> 	/	1 pièce	1 pièce	1 pièce	1 pièce
G	<p>Porte-marteau</p> 	/	1 pièce	1 pièce	1 pièce	1 pièce



H	<p>Tapis antidérapant</p> 	2 pièces	1 pièce	1 pièce	1 pièce	1 pièce
je	<p>Noix</p> 	/	12 pièces	12 pièces	12 pièces	12 pièces
J	<p>Vis</p> 	/	12 pièces	12 pièces	12 pièces	12 pièces
K	<p>Vis autotaraudeuse</p> 	12 pièces	4 pièces	4 pièces	4 pièces	4 pièces
L	<p>Chevilles</p> 	12 pièces	4 pièces	4 pièces	4 pièces	4 pièces
M	<p>Clé</p> 	/	1 pièce	1 pièce	1 pièce	1 pièce

## 15. Installation Guide for SKU1

Étape 1. Utilisez la partie K ( vis autotaraudeuse ) et la partie L ( chevilles ) pour fixer les panneaux supérieur et inférieur au mur, et la hauteur peut être définie de manière aléatoire.

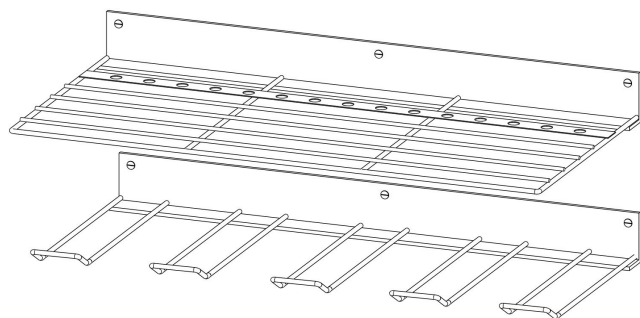

Partie A et partie B

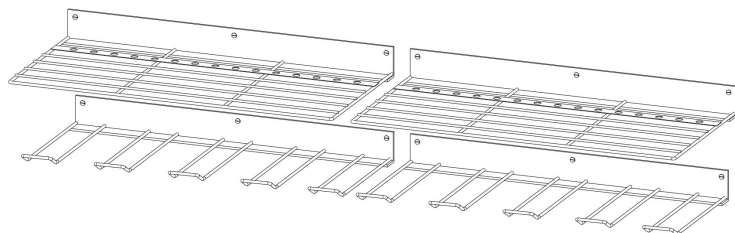

Partie A et partie

B

Étape 2. Placez la partie H (tapis antidérapant) sur la partie A.

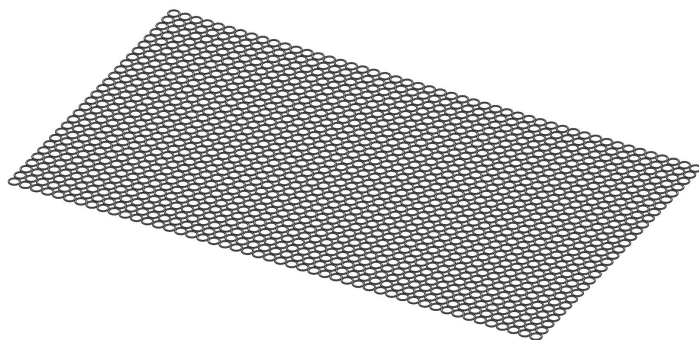

## 16. Installation Guide for SKU2 ~ SKU4

Étape 1. Comme indiqué sur l'image, localisez la pièce D (support) et placez la pièce B (panneau rainuré) et la pièce E (crochet long) entre les deux panneaux latéraux. Utilisez l'outil pièce M (clé) ainsi que les fixations pièce J (vis) et pièce I (écrou) pour fixer solidement la pièce B et la pièce E

sur la pièce D.

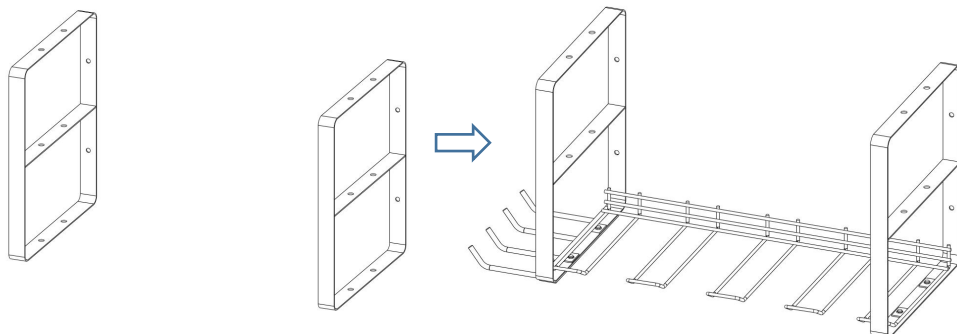

Partie D Installer la partie B et la partie E

Étape 2. Placez la pièce G (porte-marteau), la pièce F (porte-pince) et la pièce C (panneau central) dans la couche intermédiaire de la pièce D (support). Utilisez l'outil pièce M (clé) avec les fixations pièce J (vis) et pièce I (écrou) pour les fixer solidement en place.

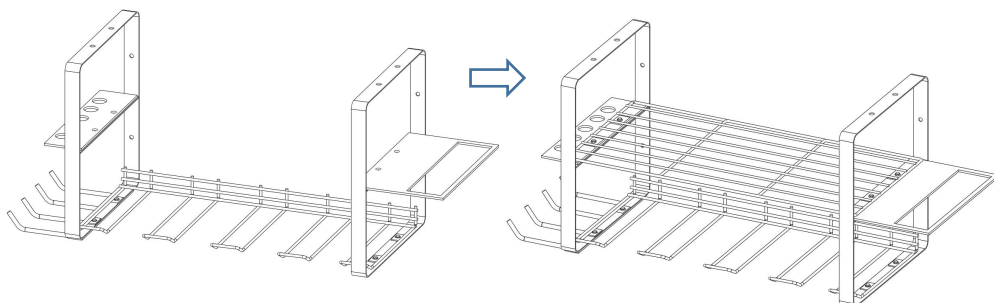

Installer la partie G et la partie F

Installer la partie C

Étape 3 : Installez la pièce A (panneau à outils). Utilisez l'outil Pièce M (clé) ainsi que les fixations Pièce J (vis) et Pièce I (écrou) pour le fixer solidement en place.

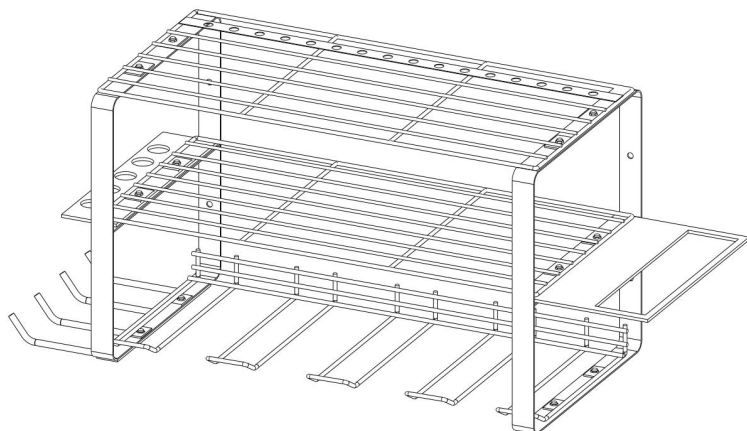

Installer la partie

A

Remarque : vous trouverez ci-dessous l'apparence des SKU2, SKU3 et SKU4 après l'installation du panneau d'outils.

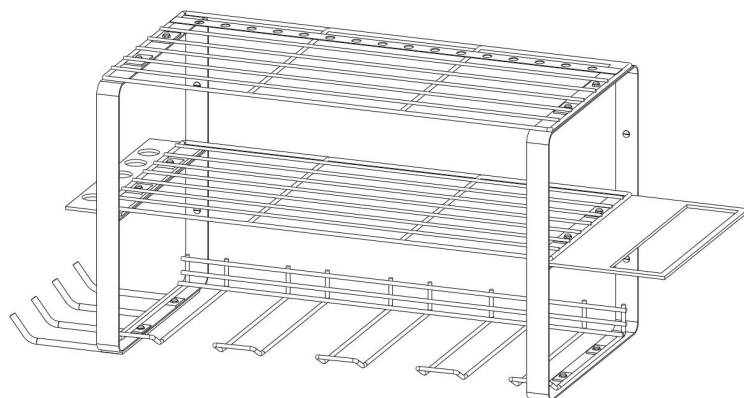

SKU2

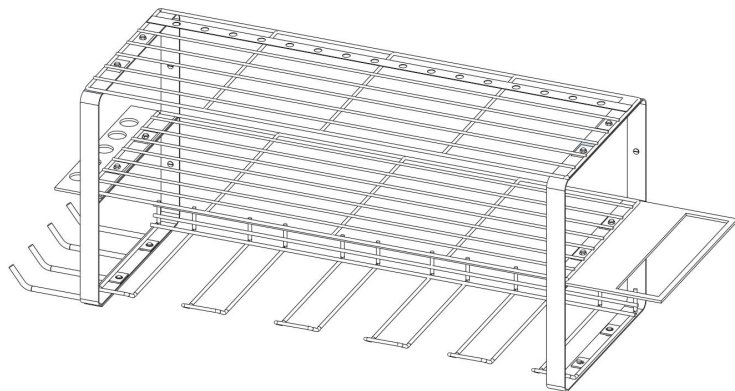

SKU3

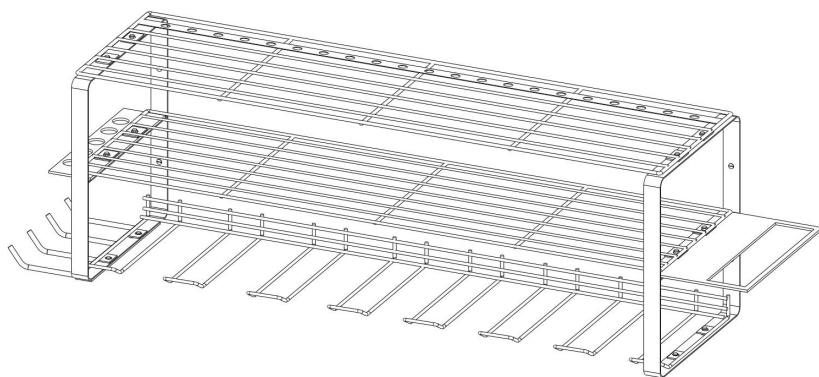

SKU4

Étape 4 : Utilisez la partie K (vis autotaraudeuse) et la partie L (chevilles) pour fixer solidement l'organiseur d'outils électriques à l'emplacement souhaité sur le mur.

Étape 5 : Placez la partie H (tapis antidérapant) sur la partie A. Le processus d'installation est terminé.

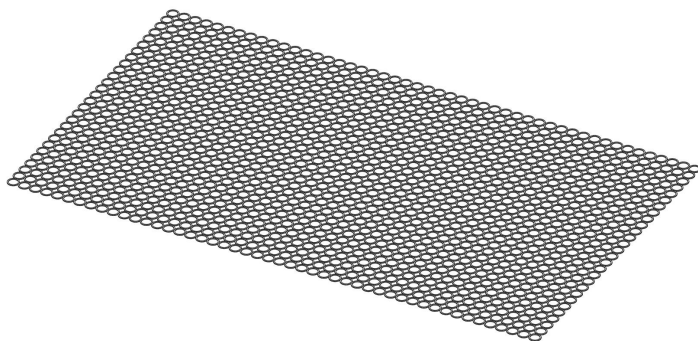

## 17. Installation Guide for SKU5

Étape 1. Comme indiqué sur l'image, localisez la pièce D (support) et placez la pièce B (panneau rainuré) et la pièce E (crochet long) entre les deux panneaux latéraux. Utilisez l'outil pièce M (clé) ainsi que les fixations pièce J (vis) et pièce I (écrou) pour fixer solidement la pièce B et la pièce E sur la pièce D.

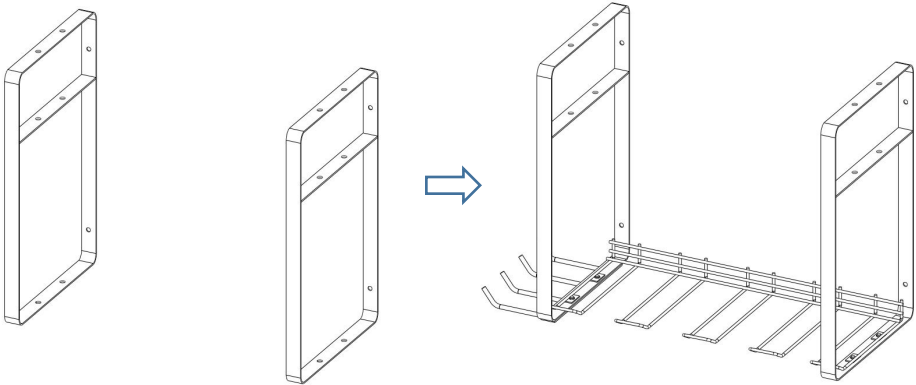

Trouver la partie D Installer la partie B et la partie E

Étape 2. Placez la partie G (porte-marteau), la partie F (porte-pince) et la partie B (panneau rainuré) dans la couche intermédiaire de la partie D (support). Utilisez l'outil Partie M (clé) avec les fixations Partie J (vis) et Partie I (écrou) pour les fixer solidement en place.

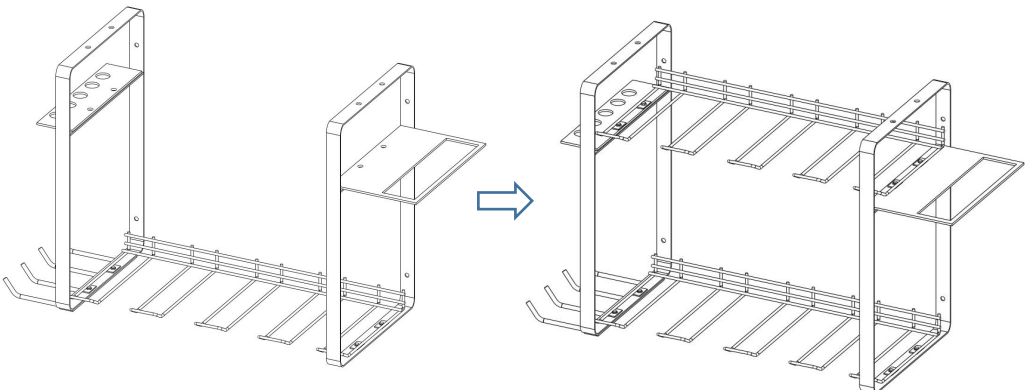

Installer la partie G et la partie F    Installer la partie B

Étape 3. Installez la partie A (panneau à outils). Utilisez l'outil de la partie M (clé) ainsi que les éléments de fixation de la partie J (vis) et de la partie I (écrou) pour le fixer solidement en place.

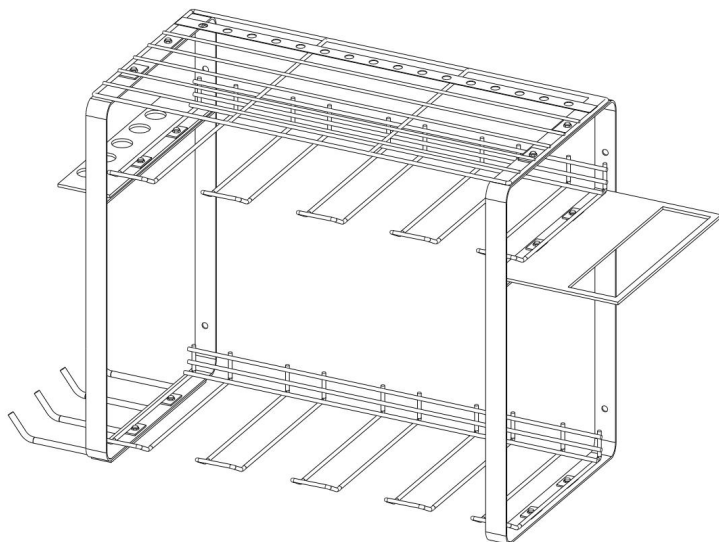

Étape 4 : Utilisez la partie K (vis autotaraudeuse) et la partie L (chevilles) pour fixer solidement l'organiseur d'outils électriques à l'emplacement souhaité sur le mur.

Étape 5 : Placez la partie H (tapis antidérapant) sur la partie A. Le processus d'installation est terminé.

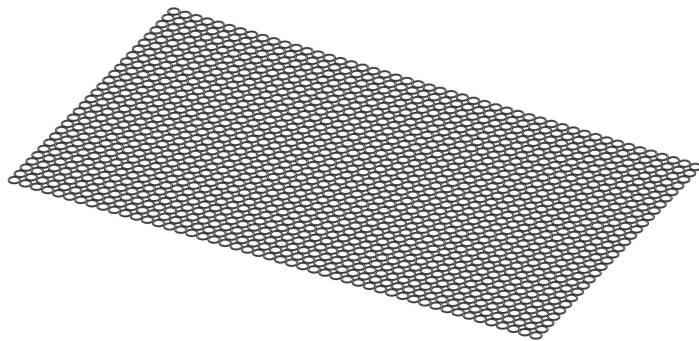

## 18. User Guide

6. Assurez-vous que les objets suspendus sur le support ne dépassent pas leur limite de poids.
7. Essayez de répartir le poids sur le cintre de manière uniforme et évitez d'être trop lourd d'un côté.
8. Ne suspendez pas d'objets tranchants ou endommagés sur le cintre, car cela pourrait le rayer ou provoquer des blessures.
9. Ajustez l'espacement des crochets selon vos besoins pour accueillir des articles de différentes tailles et formes.
10. Avant le chargement, le crochet doit être complètement placé sur le rail .



**Fabricant** : Shanghaimuxinmuyeyouxiangongsi

**Adresse** : Shuangchenglu 803nong11hao1602A-1609shi, baoshanqu, Shanghai 200000 CN.

**Importé en Australie** : SIHAO PTY LTD, 1 ROKEVA STREET, ASTWOOD NSW 2122 Australie

**Importé aux États-Unis** : Sanven Technology Ltd., Suite 250, 9166 Anaheim Place, Rancho Cucamonga, CA 91730

<b>EC</b>	<b>REP</b>
-----------	------------

E-CrossStu GmbH  
Mainzer Landstr.69, 60329 Frankfurt am Main.

<b>UK</b>	<b>REP</b>
-----------	------------

YH CONSULTING LIMITED.  
C/O YH Consulting Limited Office 147, Centurion House,  
London Road, Staines-upon-Thames, Surrey, TW18 4AX



**VEVOR**®

**TOUGH TOOLS, HALF PRICE**

**Technique Certificat d'assistance et de garantie électronique**

**[www.vevor.com/support](http://www.vevor.com/support)**

# **VEVOR<sup>®</sup>**

**TOUGH TOOLS, HALF PRICE**

Technisch Support und E-Garantie-Zertifikat

[www.vevor.com/support](http://www.vevor.com/support)

## **ORGANIZER FÜR ELEKTROWERKZEUGE BENUTZERHANDBUCH**

We continue to be committed to provide you tools with competitive price.

"Save Half", "Half Price" or any other similar expressions used by us only represents an estimate of savings you might benefit from buying certain tools with us compared to the major top brands and does not necessarily mean to cover all categories of tools offered by us. You are kindly reminded to verify carefully when you are placing an order with us if you are actually saving half in comparison with the top major brands.

# VEVOR<sup>®</sup>

TOUGH TOOLS, HALF PRICE

## POWER TOOL ORGANIZER

Modell: JC-PTO-001; JC-PTO-002; JC-PTO-003; JC-PTO-004; JC-PTO-005

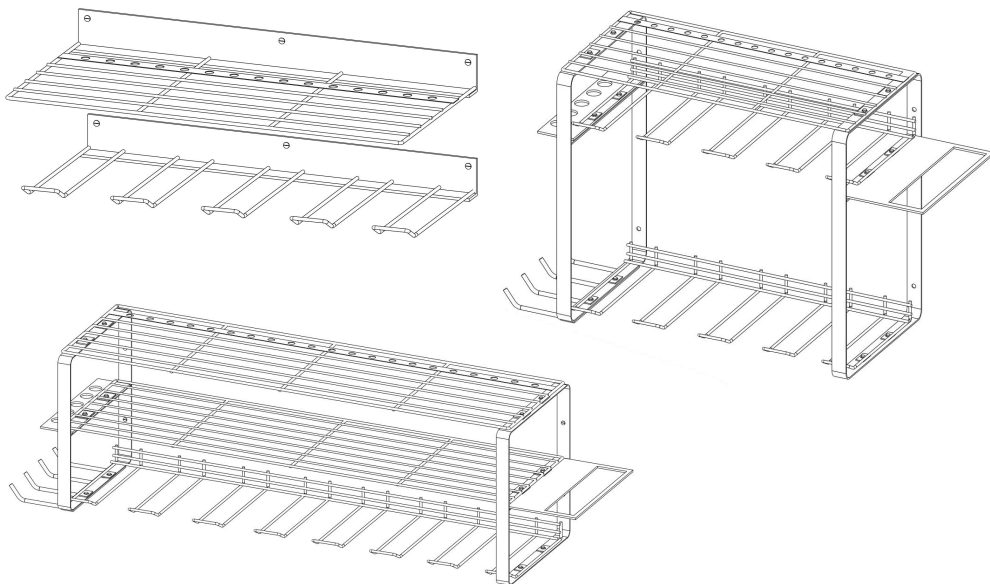

### NEED HELP? CONTACT US!

Have product questions? Need technical support? Please feel free to contact us:

**Technical Support and E-Warranty Certificate**  
[www.vevor.com/support](http://www.vevor.com/support)

This is the original instruction, please read all manual instructions carefully before operating. VEVOR reserves a clear interpretation of our user manual. The appearance of the product shall be subject to the product you received. Please forgive us that we won't inform you again if there are any technology or software updates on our product.

## 19. WARNING!

17. Stellen Sie vor der Installation sicher, dass keine versteckten Strom- oder Wasserleitungen beschädigt werden. Verwenden Sie im Zweifelsfall ein digitales Ortungsgerät oder wenden Sie sich an einen Experten.
18. Die Schiene muss auf einer stabilen Oberfläche montiert werden. Überlasten Sie sie nicht.
19. Die Montage der Wandhalterung sollte durch einen Erwachsenen erfolgen und Kinder sollten diese nicht ohne Aufsicht verwenden.
20. Nur für Ziegel und Beton empfohlen. Für die Befestigung an Gipskartonplatten oder anderen Untergründen verwenden Sie Spezialbeschläge.
21. Organizers für Elektrowerkzeuge unbedingt alle Sicherheitswarnungen und Anweisungen.
22. Bitte achten Sie darauf, dass der Werkzeughalter an einer stabilen Wand montiert wird, um ein Organizer für Elektrowerkzeuge und Werkzeuge vor dem Herunterfallen.
23. Bitte überschreiten Sie nicht die maximale Tragkraft des Elektrowerkzeug-Organizer zur Vermeidung von Schäden am Organizer für Elektrowerkzeuge und Werkzeuge vor dem Herunterfallen.
24. Bitte überprüfen Sie regelmäßig die Stabilität des Werkzeughalters und die Sicherheit der Werkzeuge .

## 20. Maintenance Guide

7. Reinigen Sie den Werkzeugorganizer regelmäßig , um die Ansammlung von Staub und Schmutz zu vermeiden.
8. Überprüfen Sie die Stabilität des Organizer für Elektrowerkzeuge, um

sicherzustellen, dass alle Befestigungsteile sicher und unbeschädigt sind.

9. Überprüfen Sie die Belastung des Elektrowerkzeug-Organizer, um sicherzustellen, dass die maximale Tragkraft nicht überschritten wird.

## 21. Product Description

Der Elektrowerkzeug-Organizer ist ein Organizer für Elektrowerkzeuge speziell für die Aufbewahrung kleiner kabelloser Elektrowerkzeuge zum Metallschneiden und -montieren (Bohrmaschinen, Schlagbohrmaschinen, elektrische Säbelsägen, elektrische Schraubendreher, elektrische Schraubenschlüssel usw.) konzipiert. Elektrowerkzeuge können am unteren Schlitz aufgehängt werden (aufrecht oder kopfüber), und in der flachen Ebene können Batterien, kleine Werkzeugkästen (mit verschiedenen Arten von Bohrern usw.) und etwas größere Werkzeuge (wie Winkelschleifer und elektrische Schneider) aufbewahrt werden. Das Produkt wird hauptsächlich in Garagen, Werkstätten und Werkzeugräumen verwendet; das Schraubendreher-Aufbewahrungsloch dient zur Aufbewahrung kleiner Handwerkzeuge wie Schraubendreher und Zangen.

## 22. Product Parameter

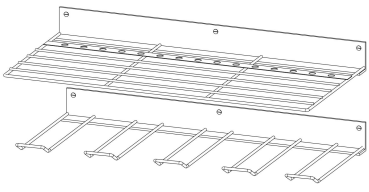
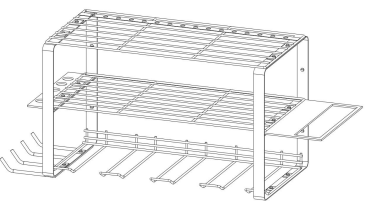
Artikel	Modell	Bild	Schichten	Rillen	NW	GW	Verpackungsgröße
Artikelnummer 1	JC-Zapfwelle-001		2	4	3,0 kg	3,3 kg	445 x 220 x 86 mm
Artikelnummer 2	JC-Zapfwelle-002		3	4	2,3 kg	2,7 kg	430*227*83 mm



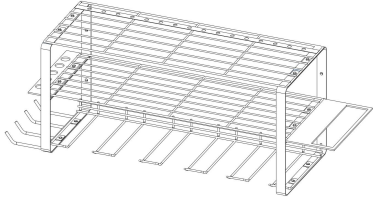
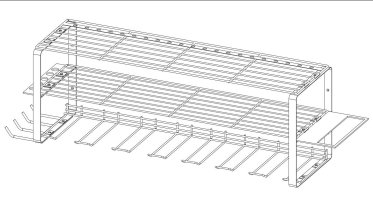
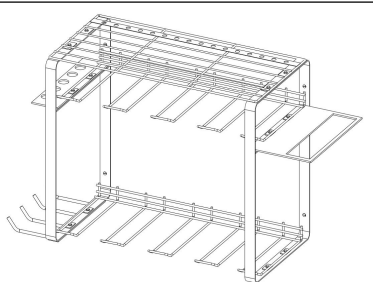



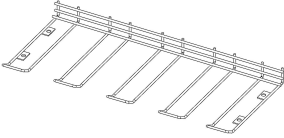
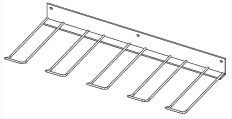
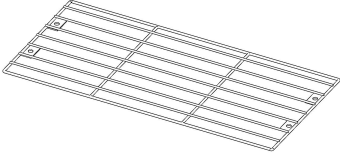
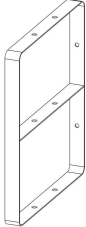
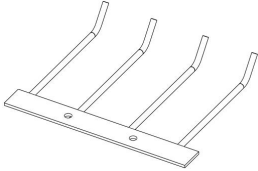
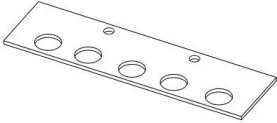
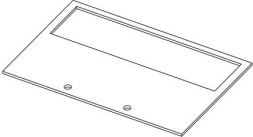

Artikelnummer 3	JC-Zapfwelle-003		3	5	2,5 kg	3,0 kg	505 x 227 x 85 mm
Artikelnummer 4	JC-PTO-004		3	7	3,0 kg	3,5 kg	655 x 225 x 80 mm
Artikelnummer 5	JC-Zapfwelle-005		3	8	2,8 kg	3,2 kg	435 x 237 x 115 mm

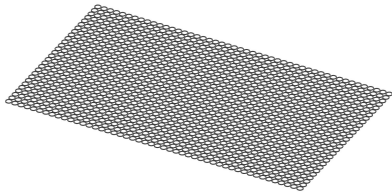
## 23. Part list

Artikel	Ersatzteile		Artikelnummer 1	Artikelnummer 2	Artikelnummer 3	Artikelnummer 4	Artikelnummer 5
			JC-Zapfwelle-001	JC-Zapfwelle-002	JC-Zapfwelle-003	JC-Zapfwelle-004	JC-Zapfwelle-005
A	Werkzeugeile	2 Stück	1 Stück	1 Stück	1 Stück	1 Stück	1 Stück

B	<p>Nutenplatte</p> 	<p>2 Stück (4 Rillen)</p> 	<p>1 Stück (4 Rillen)</p>	<p>1 Stück (5 Rillen)</p>	<p>1 Stück (7 Rillen)</p>	<p>2 Stück (4 Rillen)</p>
C	<p>Mittelteil</p> 	/	<p>1 Stück</p>	<p>1 Stück</p>	<p>1 Stück</p>	/
D	<p>Klammer</p> 	/	<p>2 Stück</p>	<p>2 Stück</p>	<p>2 Stück</p>	<p>2 Stück</p>
E	<p>Langer Haken</p> 	/	<p>1 Stück</p>	<p>1 Stück</p>	<p>1 Stück</p>	<p>1 Stück</p>
F	<p>Zangenhalter</p> 	/	<p>1 Stück</p>	<p>1 Stück</p>	<p>1 Stück</p>	<p>1 Stück</p>
G	<p>Hammerhalter</p> 	/	<p>1 Stück</p>	<p>1 Stück</p>	<p>1 Stück</p>	<p>1 Stück</p>

H	<p>Anti-Rutsch-Matte</p> 	2 Stück	1 Stück	1 Stück	1 Stück	1 Stück
ICH	<p>Nuss</p> 	/	12 pcs	12 pcs	12 pcs	12 pcs
J	<p>Schrauben</p> 	/	12 pcs	12 pcs	12 pcs	12 pcs
K	<p>Selbstschneidende Schraube</p> 	12 Stück	4 Stück	4 Stück	4 Stück	4 Stück
M	<p>Dübel</p> 	12 Stück	4 Stück	4 Stück	4 Stück	4 Stück
M	<p>Schlüssel</p> 	/	1 Stück	1 Stück	1 Stück	1 Stück

## 24. Installation Guide for SKU1

Schritt 1. Mit Teil K (Blechschaube ) und Teil L (Dübel) die oberen und unteren Paneele an der Wand befestigen, die Höhe kann beliebig festgelegt werden.

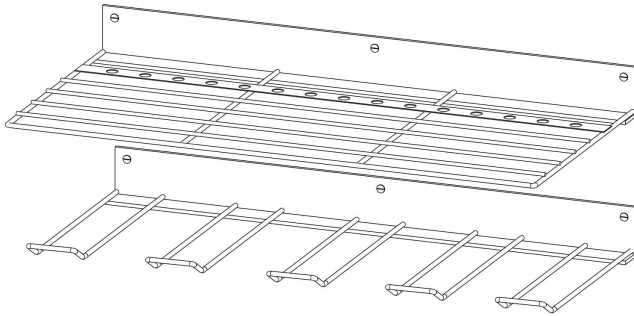

Teil A und Teil B

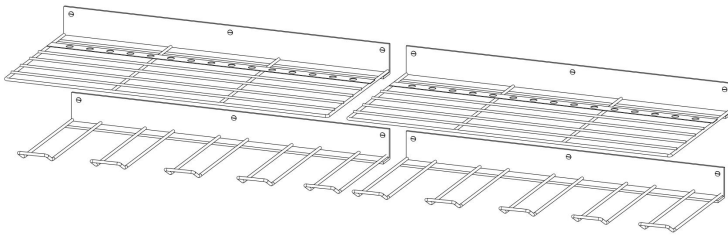

Teil A und Teil B

Schritt 2. Legen Sie Teil H (Anti-Rutsch-Matte) auf Teil A.

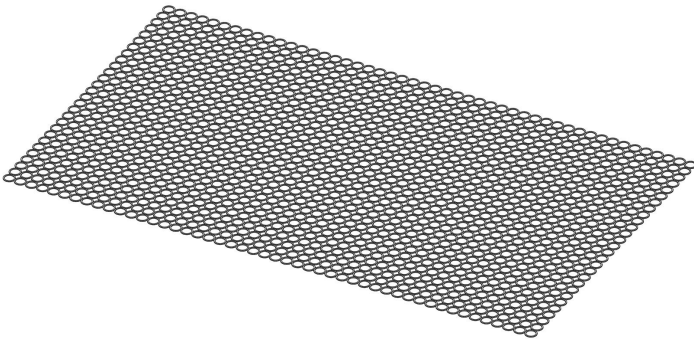

## 25. Installation Guide for SKU2 ~ SKU4

Schritt 1. Suchen Sie wie im Bild gezeigt Teil D (Klammer) und platzieren Sie Teil B (Nutplatte) und Teil E (langer Haken) zwischen den beiden Seitenplatten. Verwenden Sie das Werkzeug Teil M (Schraubenschlüssel) zusammen mit den Befestigungselementen Teil J (Schraube) und Teil I (Mutter), um Teil B und Teil E sicher an Teil D zu befestigen.

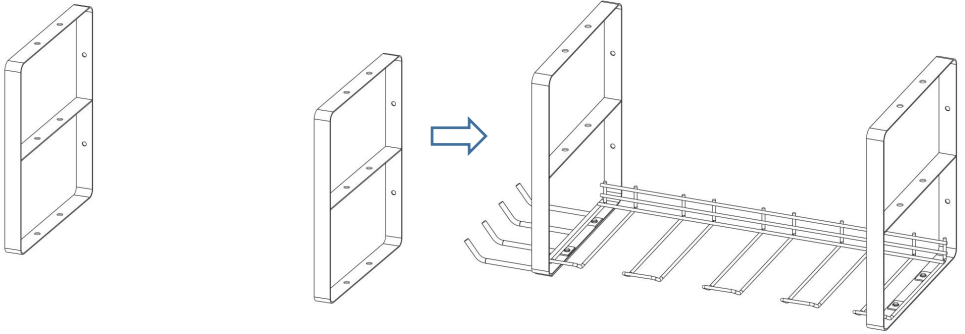

**Teil D** Installieren Sie Teil B und Teil E

**Schritt 2.** Platzieren Sie Teil G (Hammerhalter), Teil F (Zangenhalter) und Teil C (Mittelteil) in der mittleren Schicht von Teil D (Halterung). Verwenden Sie das Werkzeug Teil M (Schraubenschlüssel) zusammen mit den Befestigungselementen Teil J (Schraube) und Teil I (Mutter), um sie sicher an ihrem Platz zu befestigen.

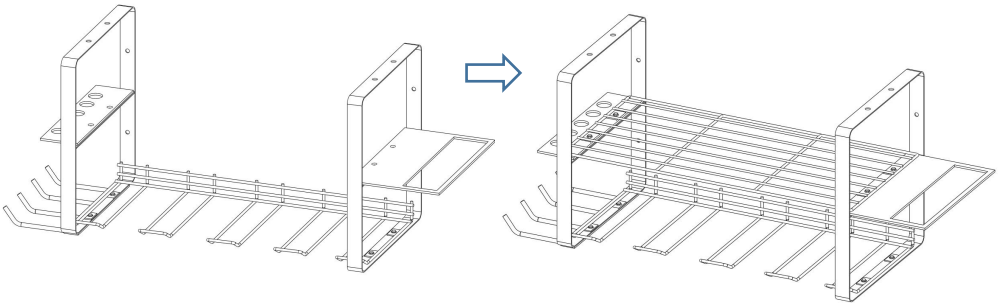

Installieren Sie Teil G und Teil F

Teil C installieren

**Schritt 3:** Installieren Sie Teil A (Werkzeugtafel). Verwenden Sie das Werkzeug Teil M (Schraubenschlüssel) zusammen mit den Befestigungselementen Teil J (Schraube) und Teil I (Mutter), um es sicher an Ort und Stelle zu befestigen.

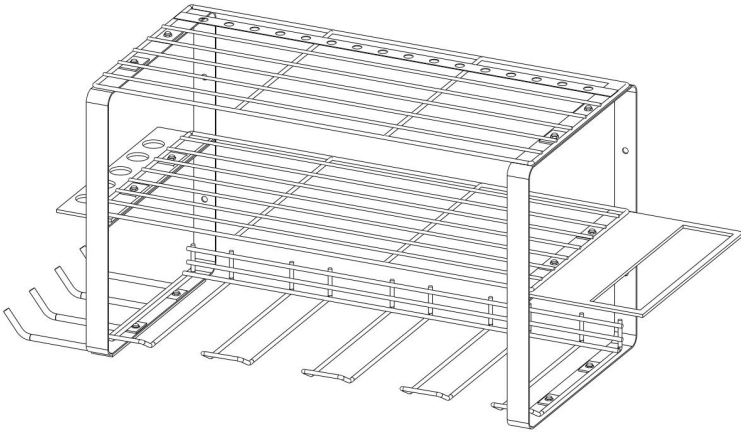

Teil A installieren

Hinweis: Unten sehen Sie das Erscheinungsbild von SKU2, SKU3 und SKU4 nach der Installation des Werkzeugfelds.

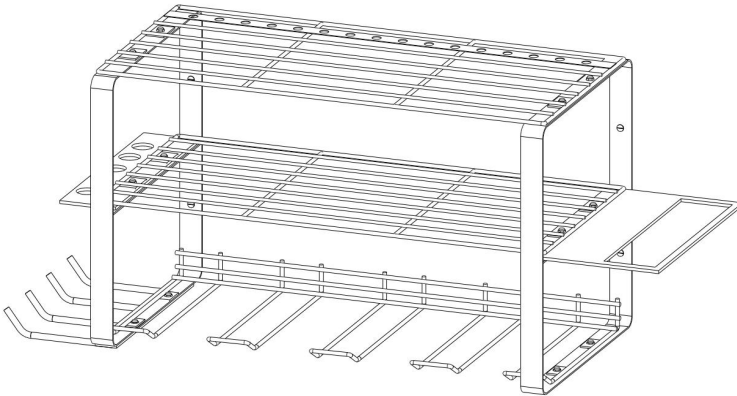

Artikelnummer 2

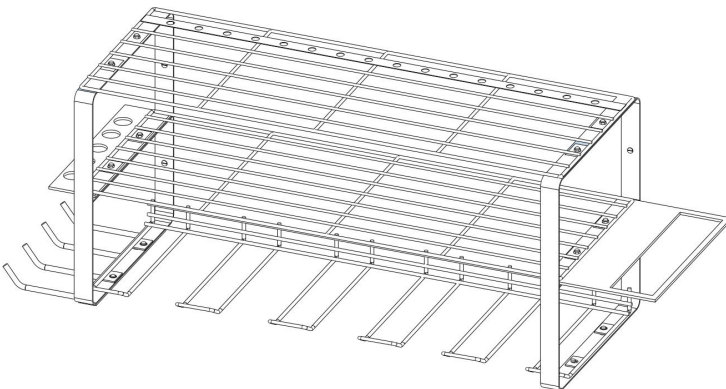

Artikelnummer 3

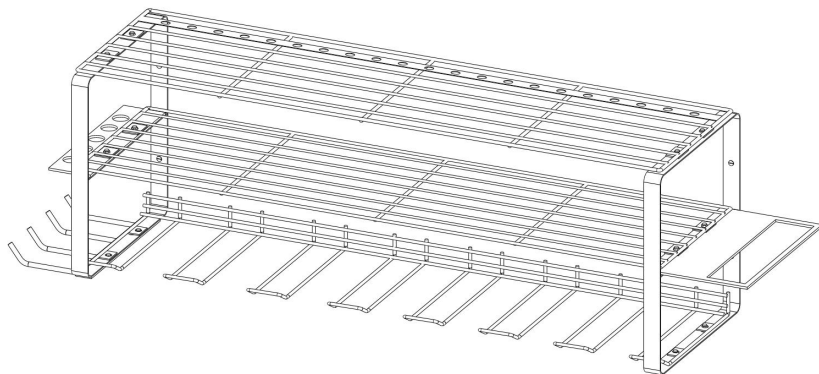

Artikelnu

mmmer 4

Schritt 4: Befestigen Sie den Elektrowerkzeug-Organizer mit Teil K (Blechschaube) und Teil L (Dübel) sicher an der gewünschten Stelle an der Wand.

Schritt 5: Legen Sie Teil H (Anti-Rutsch-Matte) auf Teil A. Der Installationsvorgang ist abgeschlossen.

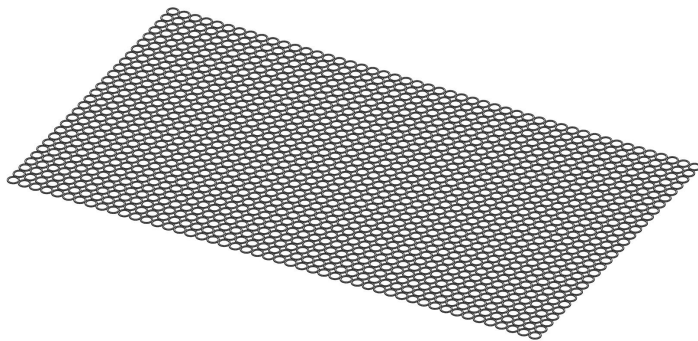

## 26. Installation Guide for SKU5

Schritt 1. Suchen Sie wie im Bild gezeigt Teil D (Klammer) und platzieren Sie Teil B (Nutplatte) und Teil E (langer Haken) zwischen den beiden Seitenplatten. Verwenden Sie das Werkzeug Teil M (Schraubenschlüssel) zusammen mit den Befestigungselementen Teil J (Schraube) und Teil I (Mutter), um Teil B und Teil E sicher an Teil D zu befestigen.

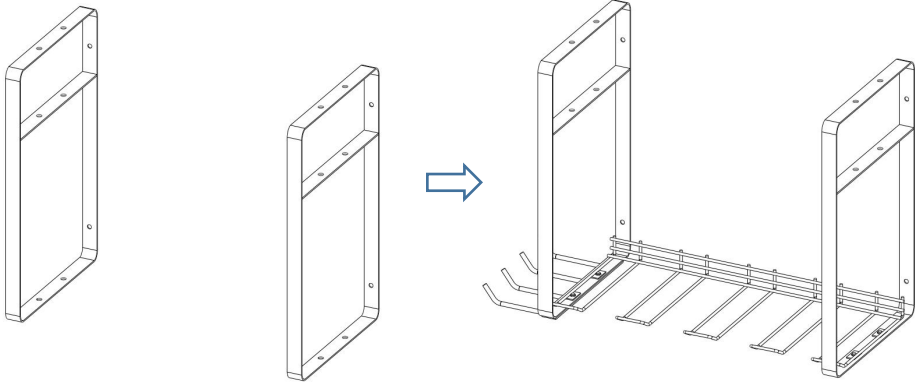

Finden Sie Teil D Installieren Sie Teil B und Teil E

Schritt 2. Platzieren Sie Teil G (Hammerhalter), Teil F (Zangenhalter) und Teil B (Nutplatte) in der mittleren Schicht von Teil D (Klammer). Verwenden Sie das Werkzeug Teil M (Schraubenschlüssel) zusammen mit den Befestigungselementen Teil J (Schraube) und Teil I (Mutter), um sie sicher an ihrem Platz zu befestigen.

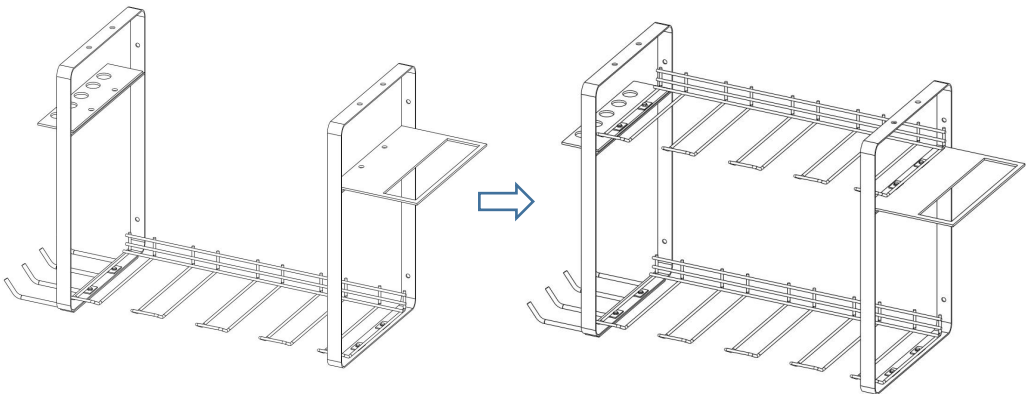

Installieren Sie Teil G und Teil F Teil B installieren

Schritt 3. Installieren Sie Teil A (Werkzeugtafel). Verwenden Sie das Werkzeug Teil M (Schraubenschlüssel) zusammen mit den Befestigungselementen Teil J (Schraube) und Teil I (Mutter), um es sicher an Ort und Stelle zu befestigen.



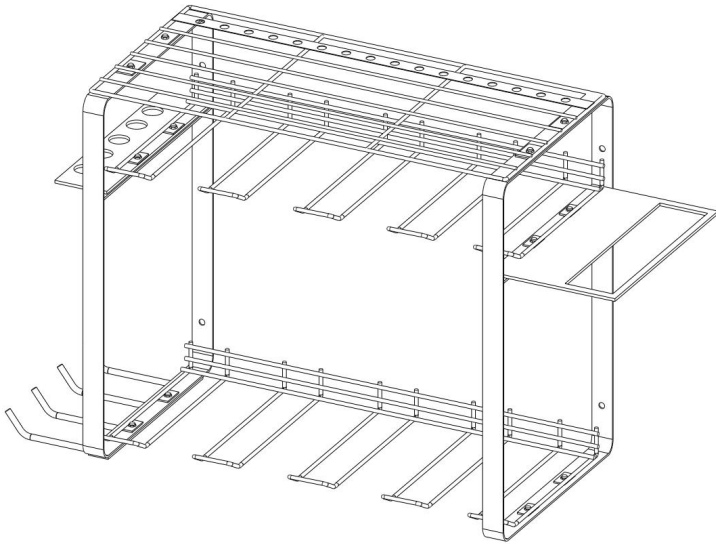

Schritt 4: Befestigen Sie den Elektrowerkzeug-Organizer mit Teil K (Blechschraube) und Teil L (Dübel) sicher an der gewünschten Stelle an der Wand.

Schritt 5: Legen Sie Teil H (Anti-Rutsch-Matte) auf Teil A. Der Installationsvorgang ist abgeschlossen.

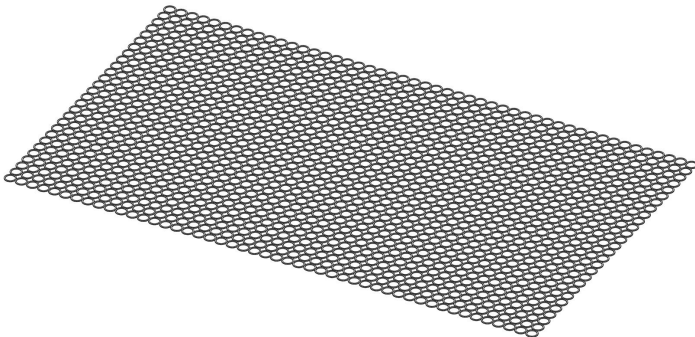

## 27. User Guide

11. Stellen Sie sicher, dass die am Gestell aufgehängten Gegenstände ihr Gewichtslimit nicht überschreiten.
12. Versuchen Sie, das Gewicht auf dem Kleiderbügel gleichmäßig zu verteilen und vermeiden Sie, dass eine Seite zu schwer ist.
13. Hängen Sie keine scharfen oder beschädigten Gegenstände an den Kleiderbügel, da dies zu Kratzern am Kleiderbügel oder zu Verletzungen führen kann.
14. Passen Sie den Abstand der Haken nach Bedarf an, um Gegenstände unterschiedlicher Größe und Form unterzubringen.
15. Vor dem Beladen muss der Haken vollständig auf der Schiene platziert werden .

**Hersteller:** Shanghaimuxinmuyeyouxiangongsi

**Adresse:** Shuangchenglu 803nong11hao1602A-1609shi, baoshanqu, Shanghai 200000 CN.

**Nach AUS importiert:** SIHAO PTY LTD, 1 ROKEVA STREETEASTWOOD NSW 2122 Australien

**Importiert in die USA:** Sanven Technology Ltd., Suite 250, 9166 Anaheim Place, Rancho Cucamonga, CA 91730

<b>EC</b>	<b>REP</b>
-----------	------------

E-CrossStu GmbH  
Mainzer Landstr.69, 60329 Frankfurt am Main.

<b>UK</b>	<b>REP</b>
-----------	------------

YH CONSULTING LIMITED.  
C/O YH Consulting Limited Office 147, Centurion House,  
London Road, Staines-upon-Thames, Surrey, TW18 4AX



**VEVOR**<sup>®</sup>

**TOUGH TOOLS, HALF PRICE**

**Technisch Support und E-Garantie-Zertifikat**

**[www.vevor.com/support](http://www.vevor.com/support)**

# **VEVOR<sup>®</sup>**

**TOUGH TOOLS, HALF PRICE**

Tecnico Supporto e certificato di garanzia elettronica

[www.vevor.com/support](http://www.vevor.com/support)

## **ORGANIZZATORE PER UTENSILI ELETTRICI MANUALE D'USO**

We continue to be committed to provide you tools with competitive price.

"Save Half", "Half Price" or any other similar expressions used by us only represents an estimate of savings you might benefit from buying certain tools with us compared to the major top brands and does not necessarily mean to cover all categories of tools offered by us. You are kindly reminded to verify carefully when you are placing an order with us if you are actually saving half in comparison with the top major brands.



# VEVOR®

TOUGH TOOLS, HALF PRICE

## POWER TOOL ORGANIZER

Modello: JC-PTO-001;JC-PTO-002;JC-PTO-003;JC-PTO-004; JC-PTO-005

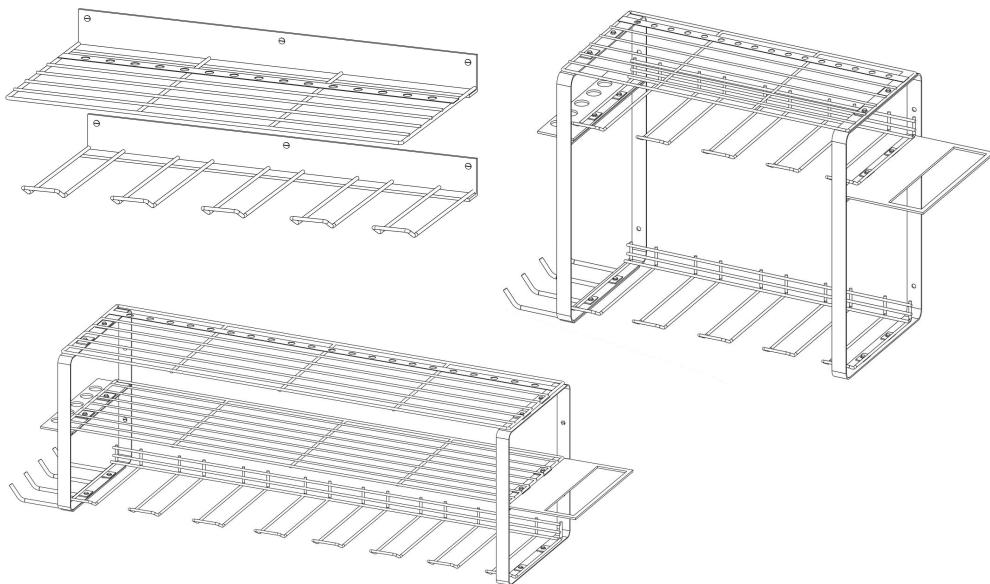

### NEED HELP? CONTACT US!

Have product questions? Need technical support? Please feel free to contact us:

**Technical Support and E-Warranty Certificate**  
**[www.vevor.com/support](http://www.vevor.com/support)**

This is the original instruction, please read all manual instructions carefully before operating. VEVOR reserves a clear interpretation of our user manual. The appearance of the product shall be subject to the product you received. Please forgive us that we won't inform you again if there are any technology or software updates on our product.



## 28. WARNING!

25. Prima dell'installazione, assicurarsi che non corra il rischio di perforare cavi elettrici nascosti o tubi dell'acqua. In caso di dubbio, utilizzare un dispositivo di tracciamento digitale o consultare un esperto.
26. La rotaia deve essere montata su una superficie stabile. Non sovraccaricare.
27. L'installazione del supporto a parete deve essere effettuata da un adulto; i bambini non devono utilizzarlo senza supervisione.
28. Consigliato solo per mattoni e cemento; per l'installazione su cartongesso o altri substrati utilizzare ferramenta speciale.
29. Prima di installare e utilizzare un organizer per utensili elettrici , assicurarsi di leggere e comprendere tutte le avvertenze e le istruzioni di sicurezza.
30. Assicurarsi che l' organizzatore per utensili elettrici sia installato su una parete stabile per evitare che organizer per utensili elettrici e protezione dagli urti.
31. Si prega di non superare la capacità di carico massima del organizzatore per utensili elettrici per evitare danni all' organizer per utensili elettrici e protezione dagli urti.
32. Controllare periodicamente la stabilità del portautensili e la sicurezza degli utensili .

## 29. Maintenance Guide

10. Pulire regolarmente l' organizzatore degli utensili per evitare l'accumulo di polvere e sporcizia.
11. Controllare la stabilità del Organizzatore per utensili elettrici per

- garantire che tutta la ferramenta di montaggio sia sicura e intatta.
12. Controllare il carico del Organizzatore per utensili elettrici per garantire che non venga superata la capacità di carico massima.

### 30. Product Description

L'organizzatore degli utensili elettrici è un organizzatore di utensili elettrici appositamente progettato per riporre piccoli utensili elettrici senza fili per il taglio e l'assemblaggio di metalli (trapani elettrici, trapani a percussione, seghetti alternativi elettrici, cacciaviti elettrici, chiavi elettriche, ecc.). Gli utensili elettrici possono essere appesi alla fessura inferiore (in verticale o capovolta) e lo strato piatto può contenere batterie, piccole cassette degli attrezzi (con diversi tipi di punte da trapano, ecc.) e utensili leggermente più grandi (come smerigliatrici angolari e taglierine elettriche). Il prodotto è utilizzato principalmente in garage, officine e sale attrezzi; il foro di stoccaggio del cacciavite è utilizzato per riporre piccoli utensili manuali come cacciaviti e pinze.

### 31. Product Parameter

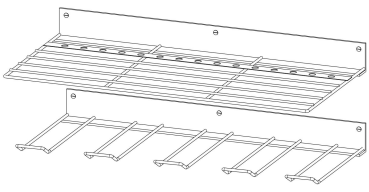
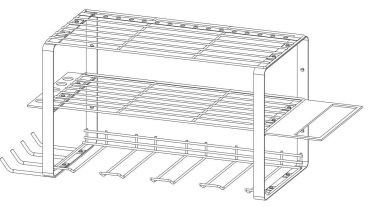

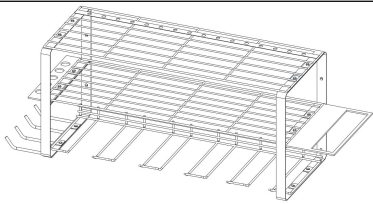
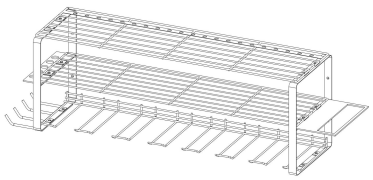
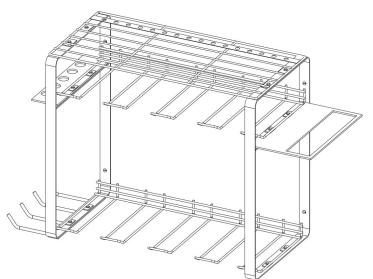

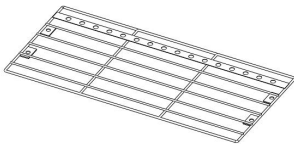
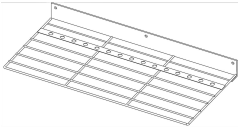

articolo	Modello	Immagine	Strati	Scanalature	Nord-Ovest	GW	Dimensioni della confezione
Codice articolo1	JC-PTO-001		2	4	3,0 kg	3,3 kg	445*220*86mm
Codice articolo2	JC-PTO-002		3	4	2,3 kg	2,7 kg	430*227*83mm

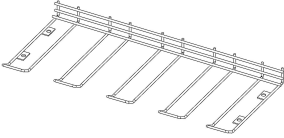
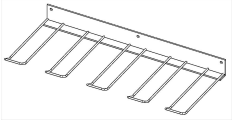
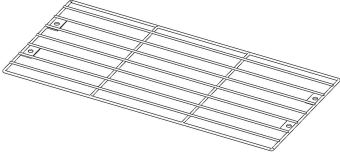
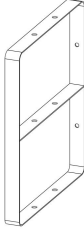
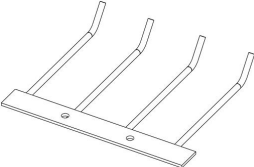
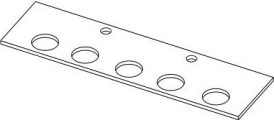
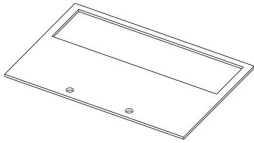
Codice articolo3	JC-PTO-003		3	5	2,5 kg	3,0 kg	505*227*85mm
Codice articolo4	JC-PTO-004		3	7	3,0 kg	3,5 kg	655*225*80mm
Codice articolo5	JC-PTO-005		3	8	2,8 kg	3,2 kg	435*237*115mm

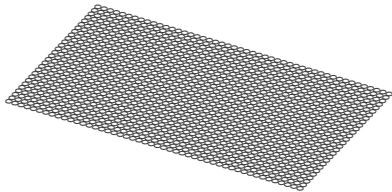
## 32. Part list

articolo	Parti		Codice Prodotto 1	Codice articolo 2	Codice articolo 3	Codice articolo 4	Codice articolo 5
			JC-PTO-001	JC-PTO-002	JC-PTO-003	JC-PTO-004	JC-PTO-005
UN	Pannello degli strumenti 	2 pezzi 		1 pz	1 pz	1 pz	1 pz

B	<p>Pannello scanalato</p> 	<p>2 pezzi (4 scanalature)</p> 	1 pz (4 scanalature)	1 pz (5 scanalature)	1 pz (7 scanalature)	2 pezzi (4 scanalature)	
C	<p>Pannello centrale</p> 		/	1 pz	1 pz	1 pz	/
D	<p>Staffa</p> 		/	2 pezzi	2 pezzi	2 pezzi	2 pezzi
E	<p>Gancio lungo</p> 		/	1 pz	1 pz	1 pz	1 pz
F	<p>Porta pinze</p> 		/	1 pz	1 pz	1 pz	1 pz
G	<p>Porta martello</p> 		/	1 pz	1 pz	1 pz	1 pz

H	<p>Tappetino antiscivolo</p> 	2 pezzi	1 pz	1 pz	1 pz	1 pz
IO	<p>Noce</p> 	/	12 pz.	12 pz.	12 pz.	12 pz.
J	<p>Vite</p> 	/	12 pz.	12 pz.	12 pz.	12 pz.
E	<p>Vite autofilettante</p> 	12 pezzi	4 pezzi	4 pezzi	4 pezzi	4 pezzi
L	<p>Tasselli</p> 	12 pezzi	4 pezzi	4 pezzi	4 pezzi	4 pezzi
M	<p>Chiave</p> 	/	1 pz	1 pz	1 pz	1 pz

### 33. Installation Guide for SKU1

Fase 1. Utilizzare la Parte K (vite autofilettante ) e la Parte L (tasselli) per fissare i pannelli superiore e inferiore alla parete; l'altezza può essere definita in modo casuale.

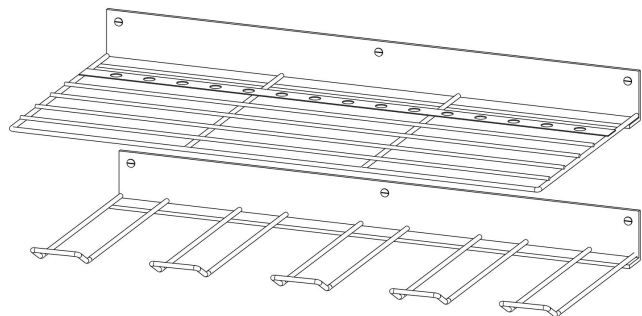

Parte A e Parte B

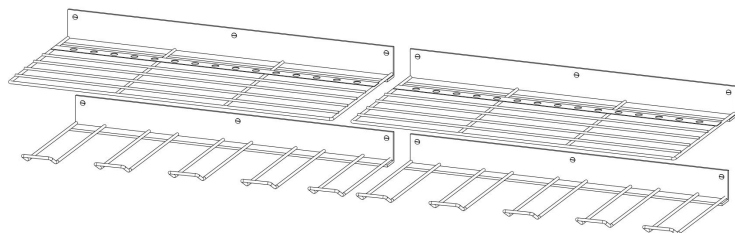

Parte A e Parte B

Fase 2. Posizionare la parte H (tappetino antiscivolo) sopra la parte A.

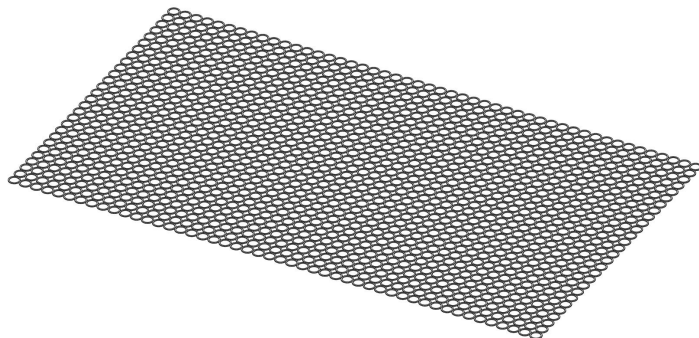

### 34. Installation Guide for SKU2 ~ SKU4

Fase 1. Come mostrato nell'immagine, individuare la Parte D (Staffa) e posizionare la Parte B (Pannello scanalato) e la Parte E (gancio lungo) tra i due pannelli laterali. Utilizzare l'utensile Parte M (chiave inglese) insieme agli elementi di fissaggio Parte J (Vite) e Parte I (Dado) per fissare saldamente la Parte B e la Parte E sulla Parte D.

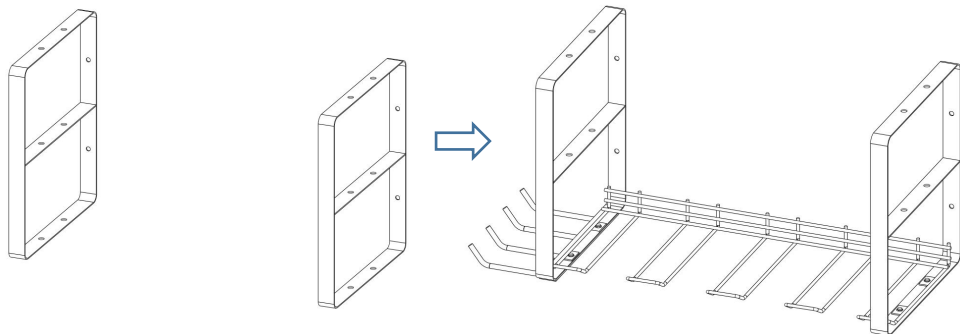

**Parte D**      **Installare la Parte B e la Parte E**

**Fase 2. Posizionare la Parte G (porta martello), la Parte F (porta pinza) e la Parte C (pannello centrale) nello strato centrale della Parte D (staffa). Utilizzare lo strumento Parte M (chiave inglese) insieme agli elementi di fissaggio Parte J (vite) e Parte I (dado) per fissarli saldamente in posizione.**

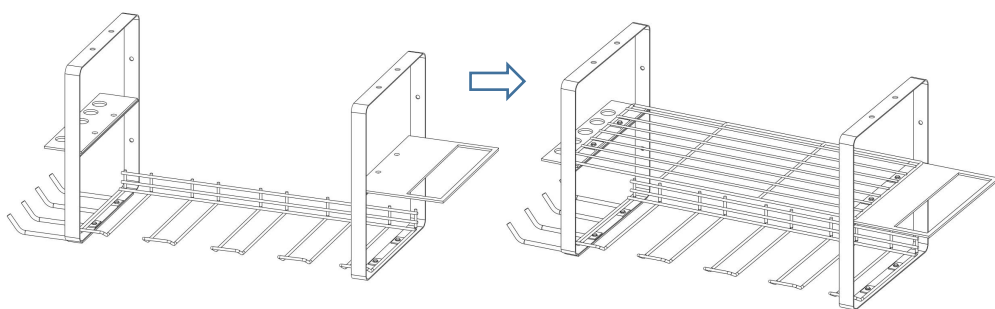

**Installare la Parte G e la Parte F**

**Installare la parte C**

**Fase 3: installare la Parte A (pannello degli utensili). Utilizzare l'utensile Parte M (chiave inglese) insieme agli elementi di fissaggio Parte J (vite) e Parte I (dado) per fissarlo saldamente in posizione.**



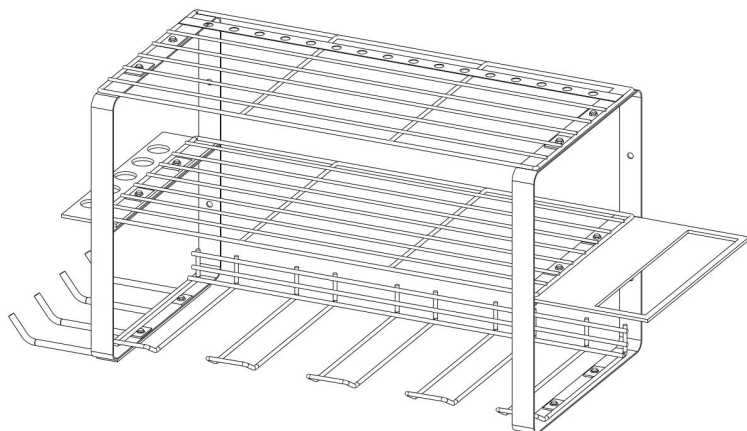

parte A

Installare la

Nota: di seguito è riportato l'aspetto di SKU2, SKU3 e SKU4 dopo l'installazione del pannello degli strumenti.

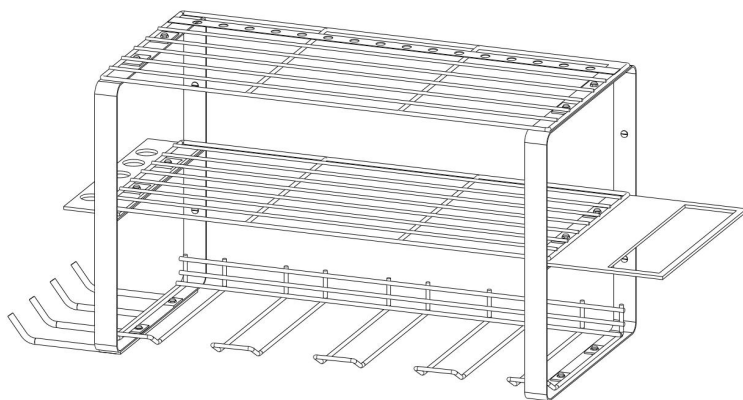

Codice articolo2

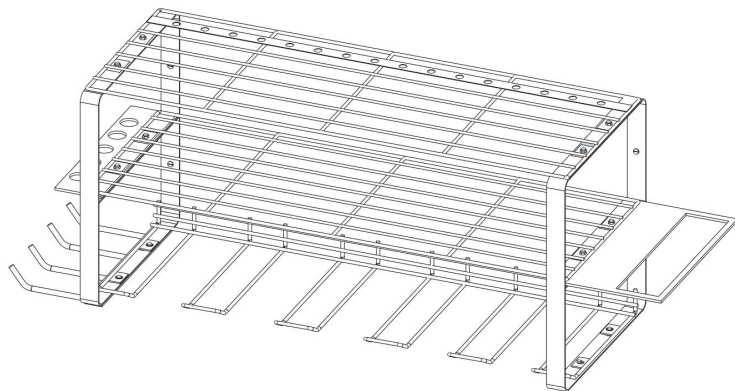

Codice articolo3

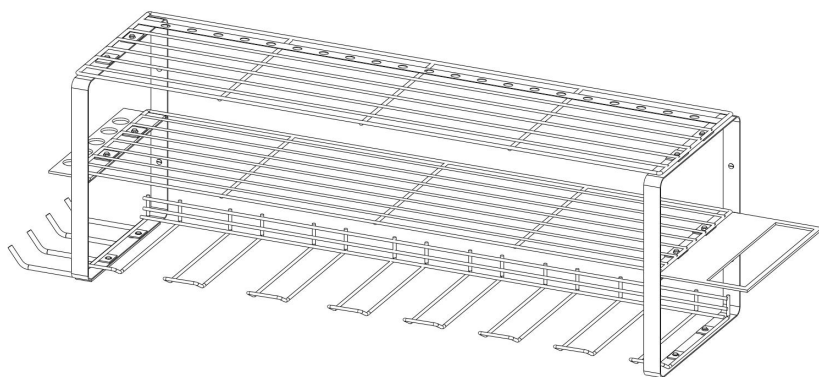

Codice

articolo4

Fase 4: Utilizzare la Parte K (vite autofilettante) e la Parte L (tasselli) per fissare saldamente l'organizzatore per elettroutensili nella posizione desiderata sulla parete.

Fase 5: Posizionare la Parte H (tappetino antiscivolo) sopra la Parte A. Il processo di installazione è completato.

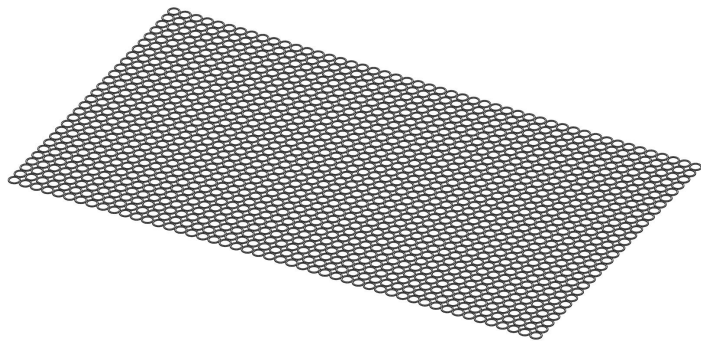

### 35. Installation Guide for SKU5

Fase 1. Come mostrato nell'immagine, individuare la Parte D (Staffa) e posizionare la Parte B (Pannello scanalato) e la Parte E (gancio lungo) tra i due pannelli laterali. Utilizzare l'utensile Parte M (chiave inglese) insieme agli elementi di fissaggio Parte J (Vite) e Parte I (Dado) per fissare saldamente la Parte B e la Parte E sulla Parte D.

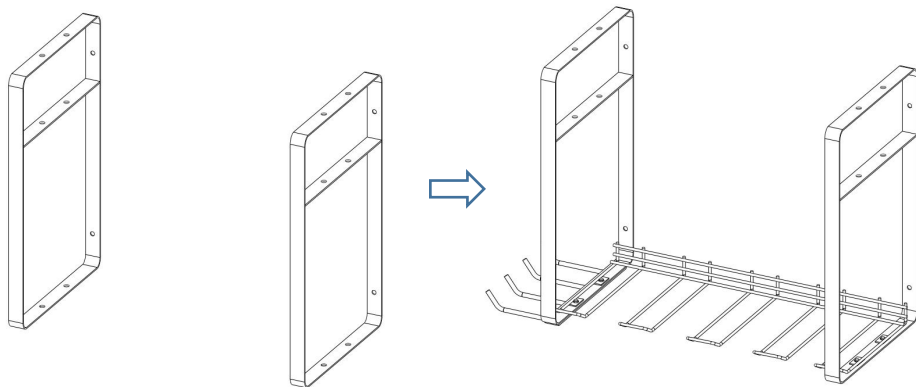

Trova la parte D Installare la Parte B e la Parte E

Fase 2. Posizionare la Parte G (porta martello), la Parte F (porta pinza) e la Parte B (pannello scanalato) nello strato centrale della Parte D (staffa). Utilizzare lo strumento Parte M (chiave inglese) insieme agli elementi di fissaggio Parte J (vite) e Parte I (dado) per fissarli saldamente in posizione.

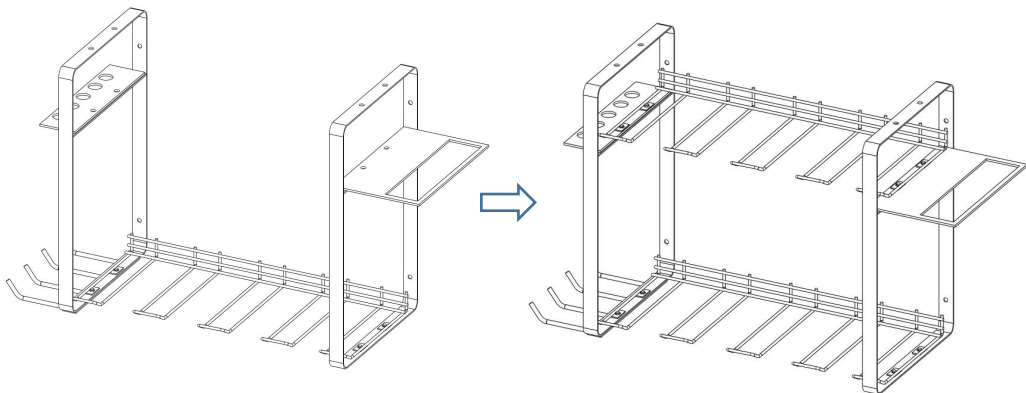

Installare la Parte G e la Parte F    Installare la parte B

Fase 3. Installare la Parte A (pannello degli utensili). Utilizzare l'utensile Parte M (chiave) insieme agli elementi di fissaggio Parte J (vite) e Parte I (dado) per fissarlo saldamente in posizione.

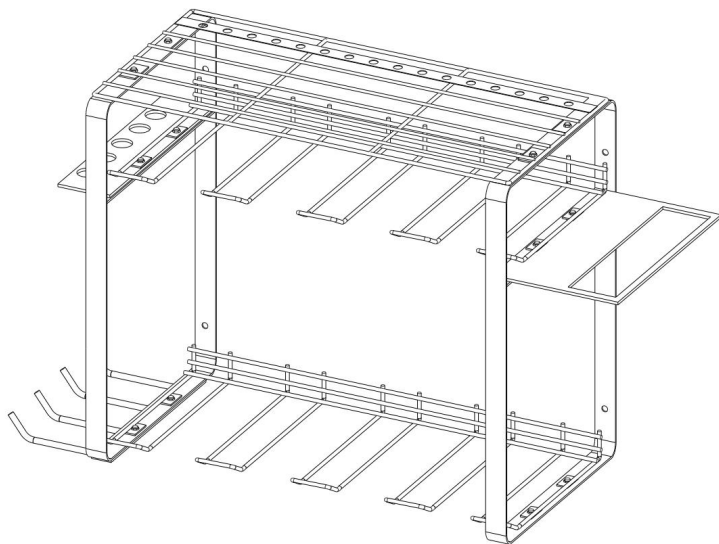

Fase 4: Utilizzare la Parte K (vite autofilettante) e la Parte L (tasselli) per fissare saldamente l'organizzatore per elettroutensili nella posizione desiderata sulla parete.

Fase 5: Posizionare la Parte H (tappetino antiscivolo) sopra la Parte A. Il processo di installazione è completato.

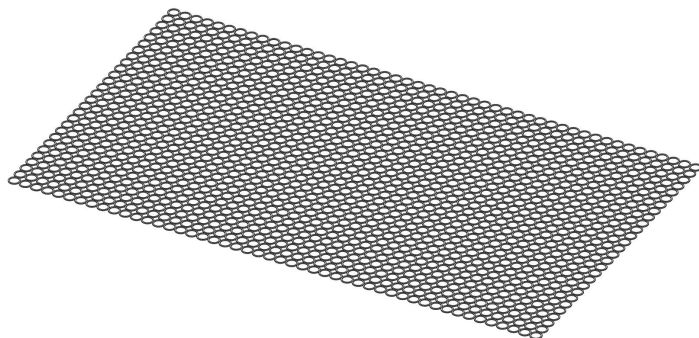

## 36. User Guide

16. Assicurarsi che gli oggetti appesi al rack non superino il peso massimo consentito.
17. Cerca di distribuire il peso sulla gruccia in modo uniforme ed evita di appesantirla troppo da un lato.
18. Non appendere oggetti appuntiti o danneggiati all'appendino, poiché potrebbero graffiarlo o causare lesioni.
19. Regolare la spaziatura dei ganci in base alle esigenze per adattare oggetti di diverse dimensioni e forme.
20. Prima del carico, il gancio deve essere completamente posizionato sulla rotaia .

**Produttore:** Shanghaimuxinmuyeyouxiangongsi

**Indirizzo:** Shuangchenglu 803nong11hao1602A-1609shi, baoshanqu, shanghai 200000 CN.

**Importato in AUS:** SIHAO PTY LTD, 1 ROKEVA STREETEASTWOOD NSW 2122 Australia

**Importato negli USA:** Sanven Technology Ltd., Suite 250, 9166 Anaheim Place, Rancho Cucamonga, CA 91730

<b>EC</b>	<b>REP</b>
-----------	------------

E-CrossStu GmbH  
Mainzer Landstr.69, 60329 Frankfurt am Main.

<b>UK</b>	<b>REP</b>
-----------	------------

YH CONSULTING LIMITED.  
C/O YH Consulting Limited Office 147, Centurion House,  
London Road, Staines-upon-Thames, Surrey, TW18 4AX



**VEVOR**®

**TOUGH TOOLS, HALF PRICE**

**Tecnico Supporto e certificato di garanzia elettronica**

**[www.vevor.com/support](http://www.vevor.com/support)**



# **VEVOR<sup>®</sup>**

**TOUGH TOOLS, HALF PRICE**

Técnico Certificado de soporte y garantía electrónica

[www.vevor.com/support](http://www.vevor.com/support)

## **ORGANIZADOR DE HERRAMIENTAS ELÉCTRICAS MANUAL DEL USUARIO**

We continue to be committed to provide you tools with competitive price. "Save Half", "Half Price" or any other similar expressions used by us only represents an estimate of savings you might benefit from buying certain tools with us compared to the major top brands and does not necessarily mean to cover all categories of tools offered by us. You are kindly reminded to verify carefully when you are placing an order with us if you are actually saving half in comparison with the top major brands.



# VEVOR®

TOUGH TOOLS, HALF PRICE

## POWER TOOL ORGANIZER

Modelo: JC-PTO-001; JC-PTO-002; JC-PTO-003; JC-PTO-004; JC-PTO-005

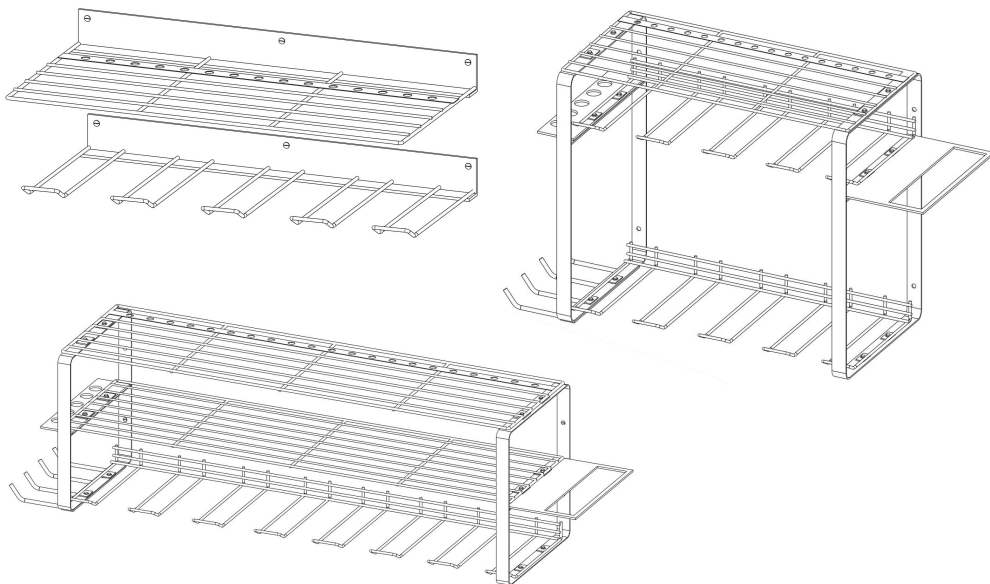

### NEED HELP? CONTACT US!

Have product questions? Need technical support? Please feel free to contact us:

**Technical Support and E-Warranty Certificate**  
[www.vevor.com/support](http://www.vevor.com/support)

This is the original instruction, please read all manual instructions carefully before operating. VEVOR reserves a clear interpretation of our user manual. The appearance of the product shall be subject to the product you received. Please forgive us that we won't inform you again if there are any technology or software updates on our product.

## **37. ⚠️WARNING!**

33. Antes de la instalación, asegúrese de que no exista riesgo de perforar cables de corriente o tuberías de agua ocultos. En caso de duda, utilice un dispositivo de seguimiento digital o consulte a un experto.
34. El riel debe montarse sobre una superficie estable. No lo sobrecargue.
35. La instalación del soporte de pared debe ser realizada por un adulto y los niños no deben utilizarlo sin supervisión.
36. Recomendado únicamente para ladrillo y hormigón; utilice herrajes especiales para instalarlo en placas de yeso u otros sustratos.
37. Antes de instalar y utilizar un organizador de herramientas eléctricas , asegúrese de leer y comprender todas las advertencias e instrucciones de seguridad.
38. Asegúrese de que el organizador de herramientas eléctricas esté instalado en una pared estable para evitar que Organizador de herramientas eléctricas y herramientas para evitar que se caigan.
39. No exceda la capacidad máxima de carga del Organizador de herramientas eléctricas para evitar daños en las mismas. Organizador de herramientas eléctricas y herramientas para evitar que se caigan.
40. Compruebe periódicamente la estabilidad del portaherramientas y la seguridad de las herramientas .

## **38. Maintenance Guide**

13. Limpie periódicamente el organizador de herramientas para evitar la acumulación de polvo y suciedad.
14. Compruebe la estabilidad de la Organizador de herramientas eléctricas para garantizar que todo el hardware de montaje esté seguro y sin daños.

15. Compruebe la carga del Organizador de herramientas eléctricas para garantizar que no se exceda la capacidad de carga máxima.

### 39. Product Description

El organizador de herramientas eléctricas es un organizador de herramientas eléctricas Especialmente diseñado para almacenar pequeñas herramientas eléctricas inalámbricas de corte y montaje de metales (taladro eléctrico, taladro de impacto, sierra eléctrica alternativa, destornillador eléctrico, llave eléctrica, etc.). Las herramientas eléctricas se pueden colgar en la ranura inferior (en posición vertical o al revés), y la capa plana puede almacenar baterías, pequeñas cajas de herramientas (con diferentes tipos de brocas, etc.) y herramientas un poco más grandes (como amoladoras angulares y cortadoras eléctricas). El producto se utiliza principalmente en garajes, talleres y salas de herramientas; el orificio de almacenamiento del destornillador se utiliza para colocar pequeñas herramientas manuales como destornilladores y alicates.

### 40. Product Parameter

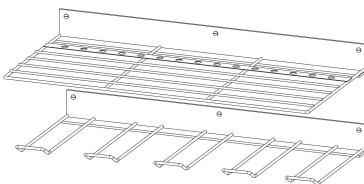
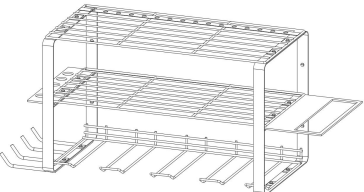
artículo	Modelo	Imagen	Capas	Surcos	noeste	GW	Tamaño del embalaje
Código 1	JC-Toma de fuerza a-001		2	4	3,0 kilogramos	3,3 kilos	445*220*86 mm
Código 2	JC-Toma de fuerza a-002		3	4	2,3 kilos	2,7 kilos	430*227*83 mm

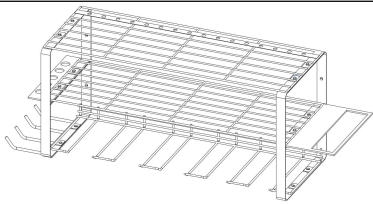
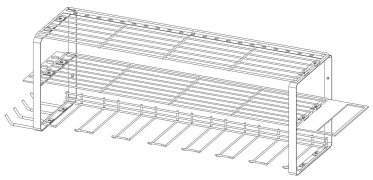
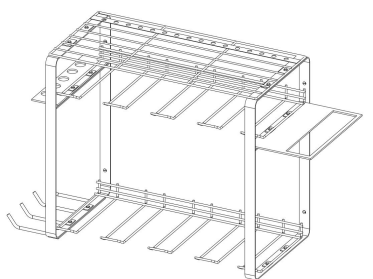



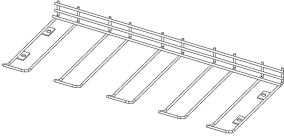
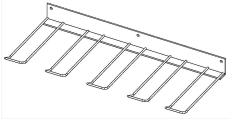
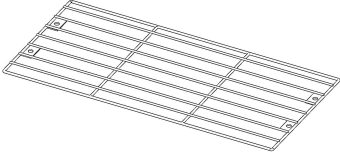
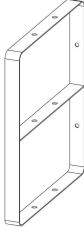
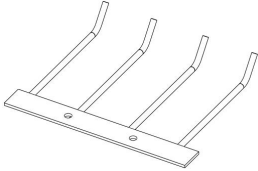
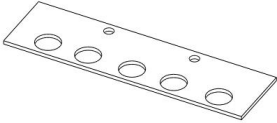
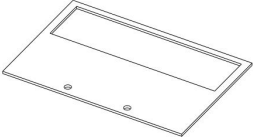

Código 3	JC-Toma de fuerza-003		3	5	2,5 kilos	3,0 kilogramos	505*227*85 mm
Código 4	JC-PTO-004		3	7	3,0 kilogramos	3,5 kilos	655*225*80 mm
Código 5	JC-PTO-005		3	8	2,8 kilos	3,2 kilos	435*237*115 mm

## 41. Part list

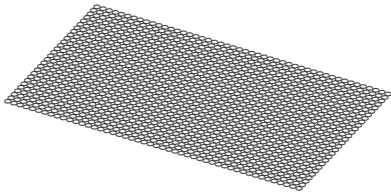
artículo	Regiones		Código o SKU 1	Código 2	Código 3	Código 4	Código 5
			JC-Toma de fuerza-001	JC-Toma de fuerza-002	JC-Toma de fuerza-003	JC-PTO-004	JC-PTO-005
A	Panel de herramientas	2 piezas	1 pieza	1 pieza	1 pieza	1 pieza	1 pieza

B	<p>Panel ranurado</p> 	<p>2 piezas (4 ranuras)</p> 	1 pieza (4 ranur as)	1 pieza (5 ranur as)	1 pieza (7 ranur as)	2 pieza s (4 ranur as)
do	<p>Panel central</p> 	/	1 pieza	1 pieza	1 pieza	/
D	<p>Soporte</p> 	/	2 pieza s	2 pieza s	2 pieza s	2 pieza s
mi	<p>Gancho largo</p> 	/	1 pieza	1 pieza	1 pieza	1 pieza
F	<p>Porta pinzas</p> 	/	1 pieza	1 pieza	1 pieza	1 pieza
GRA MO	<p>Soporte para martillo</p> 	/	1 pieza	1 pieza	1 pieza	1 pieza



yo	<p>Alfombrilla antideslizante</p> 	2 pieza s	1 pieza	1 pieza	1 pieza	1 pieza
I	<p>Tuerca</p> 	/	12 pieza s	12 pieza s	12 pieza s	12 pieza s
Yo	<p>Tornillo</p> 	/	12 pieza s	12 pieza s	12 pieza s	12 pieza s
K	<p>Tornillo autorroscante</p> 	12 pieza s	4 pieza s	4 pieza s	4 pieza s	4 pieza s
yo	<p>Pasadores</p> 	12 pieza s	4 pieza s	4 pieza s	4 pieza s	4 pieza s
MET RO	<p>Llave inglesa</p> 	/	1 pieza	1 pieza	1 pieza	1 pieza

## 42. Installation Guide for SKU1

Paso 1. Utilice la Parte K ( tornillo autorroscante ) y la Parte L (Tacos) para fijar los paneles superior e inferior a la pared; la altura se puede definir aleatoriamente.

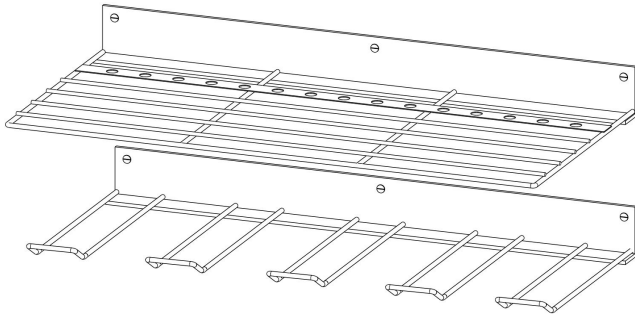

Parte A y Parte B

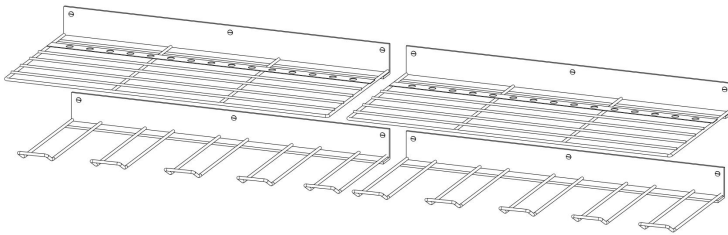

Parte A y Parte B

Paso 2. Coloque la parte H (alfombrilla antideslizante) encima de la parte A.

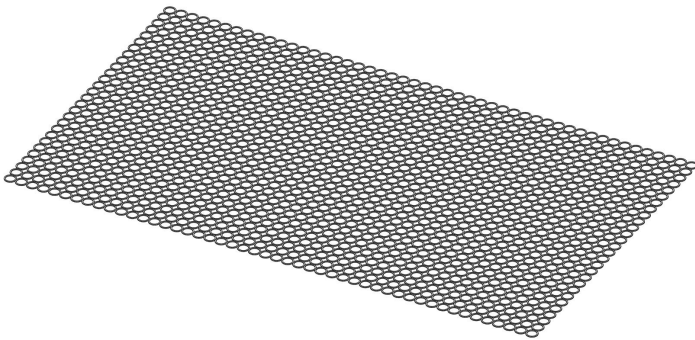

### 43. Installation Guide for SKU2 ~ SKU4

Paso 1. Como se muestra en la imagen, ubique la Pieza D (Soporte) y coloque la Pieza B (Panel de ranura) y la Pieza E (Gancho largo) entre los dos paneles laterales. Use la herramienta Pieza M (Llave) junto con los sujetadores Pieza J (Tornillo) y Pieza I (Tuerca) para sujetar firmemente la

Pieza B y la Pieza E a la Pieza D.

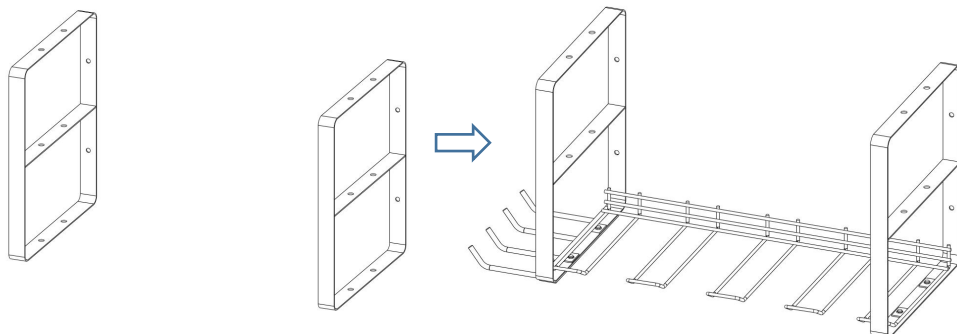

Parte D          Instalar la Parte B y la Parte E

Paso 2. Coloque la Parte G (Soporte del martillo), la Parte F (Soporte de los alicates) y la Parte C (Panel intermedio) en la capa intermedia de la Parte D (Soporte). Use la herramienta Parte M (llave) junto con los sujetadores Parte J (Tornillo) y Parte I (Tuerca) para fijarlos firmemente en su lugar.

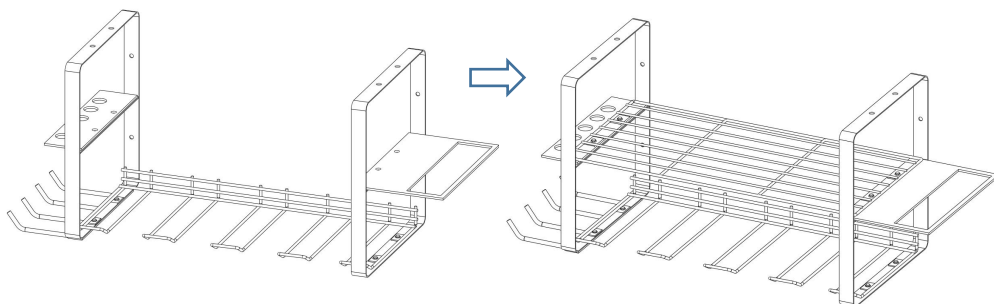

Instalar la Parte G y la Parte F

Instalar la parte C

Paso 3: Instale la pieza A (panel de herramientas). Utilice la pieza M (llave) junto con los sujetadores J (tornillo) y I (tuerca) para fijarla en su lugar.

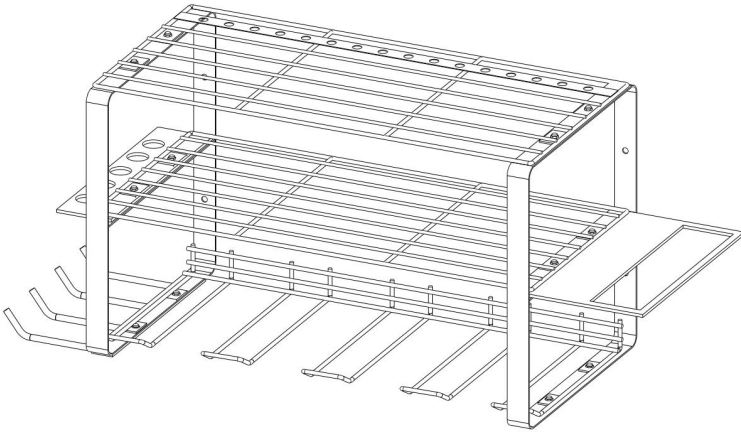

Instalar la parte

A

Nota: A continuación se muestra la apariencia de SKU2, SKU3 y SKU4 después de instalar el panel de herramientas.

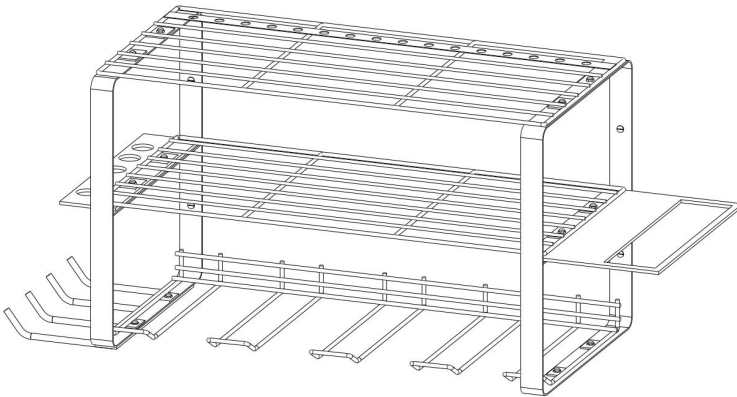

Código 2

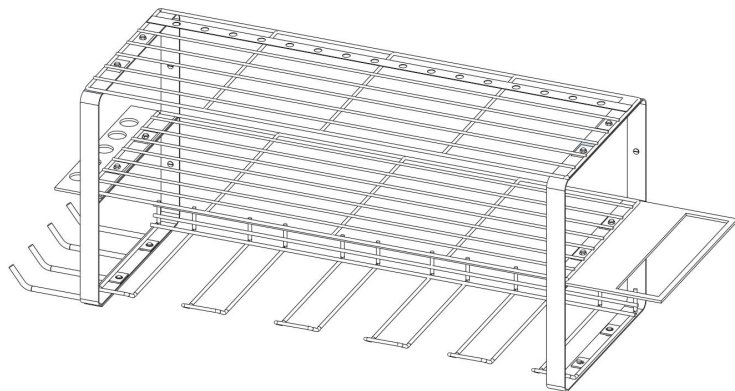

Código 3

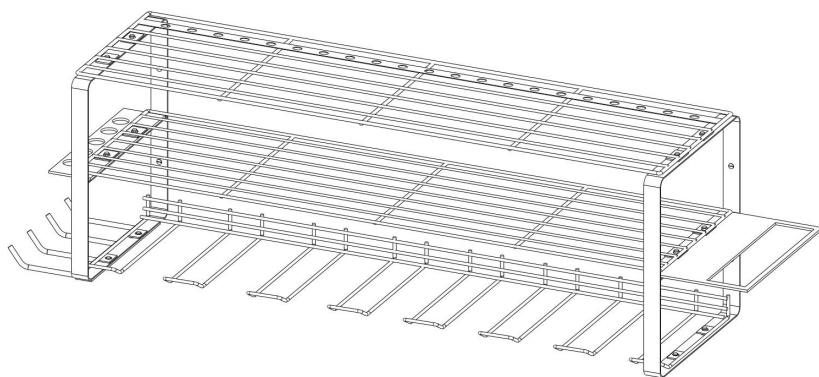

Código 4

Paso 4: Use la Parte K (tornillo autorroscante) y la Parte L (Tacos) para fijar firmemente el organizador de herramientas eléctricas en la ubicación deseada en la pared.

Paso 5: Coloque la Parte H (alfombrilla antideslizante) encima de la Parte A. El proceso de instalación está completo.

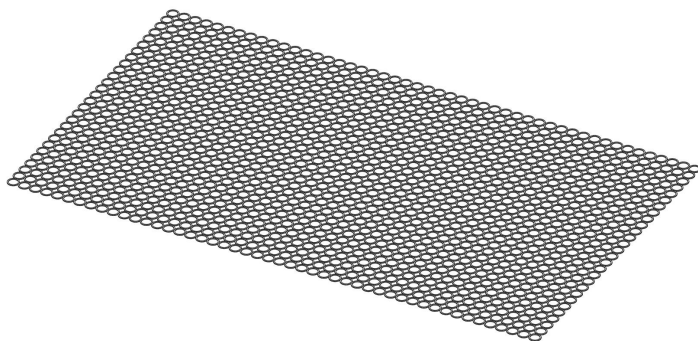

## 44. Installation Guide for SKU5

Paso 1. Como se muestra en la imagen, ubique la Pieza D (Soporte) y coloque la Pieza B (Panel de ranura) y la Pieza E (Gancho largo) entre los dos paneles laterales. Use la herramienta Pieza M (Llave) junto con los sujetadores Pieza J (Tornillo) y Pieza I (Tuerca) para sujetar firmemente la Pieza B y la Pieza E a la Pieza D.

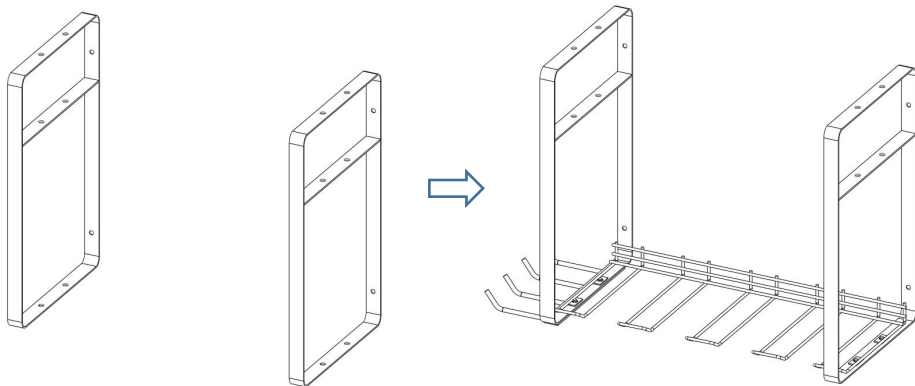

Encuentre la Parte D Instalar la Parte B y la Parte E

Paso 2. Coloque la Parte G (Soporte del martillo), la Parte F (Soporte de los alicates) y la Parte B (Panel de ranura) en la capa intermedia de la Parte D (Soporte). Use la herramienta Parte M (llave) junto con los sujetadores Parte J (Tornillo) y Parte I (Tuerca) para fijarlas firmemente en su lugar.

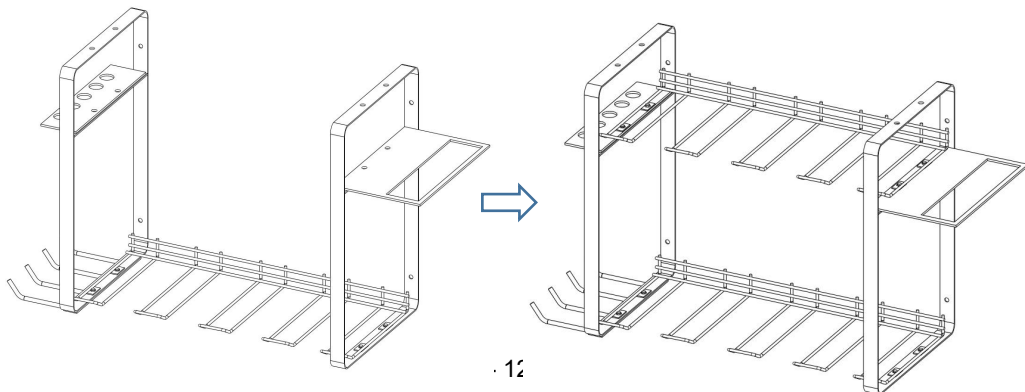

Instalar la Parte G y la Parte F    Instalar la parte B

Paso 3. Instale la pieza A (panel de herramientas). Utilice la herramienta pieza M (llave) junto con los sujetadores pieza J (tornillo) y pieza I (tuerca) para fijarla en su lugar de forma segura.

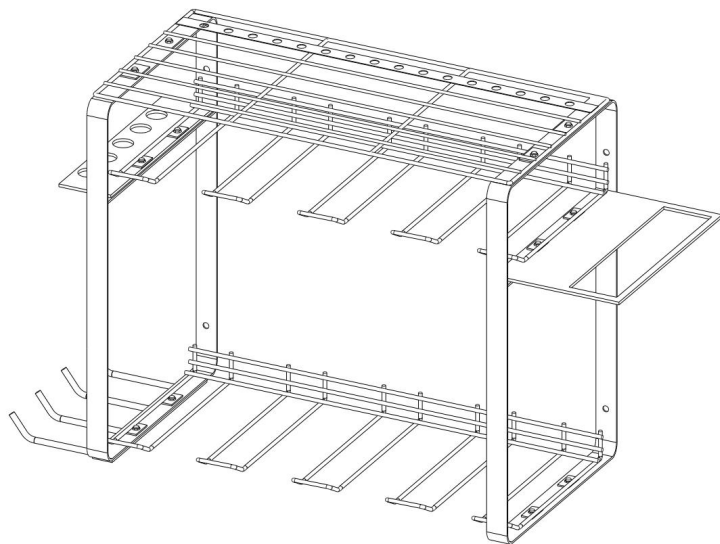

Paso 4: Use la Parte K (tornillo autorroscante) y la Parte L (Tacos) para fijar firmemente el organizador de herramientas eléctricas en la ubicación deseada en la pared.

Paso 5: Coloque la Parte H (alfombrilla antideslizante) encima de la Parte A. El proceso de instalación está completo.

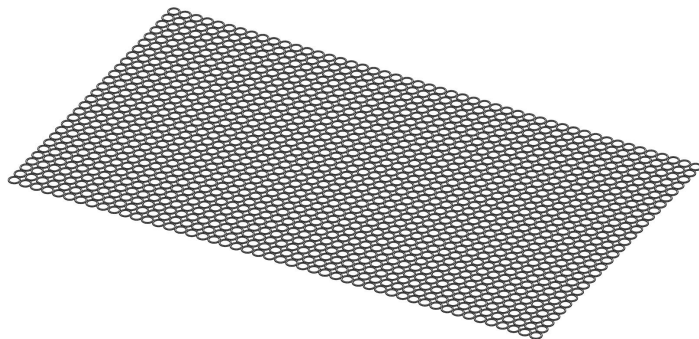

## 45. User Guide

21. Asegúrese de que los artículos colgados en el estante no excedan su límite de peso.
22. Intente distribuir el peso en la percha de manera uniforme y evite que esté demasiado pesado en un lado.
23. No cuelgue objetos afilados o dañados en la percha, ya que esto podría rayarla o provocar lesiones.
24. Ajuste el espacio entre los ganchos según sea necesario para acomodar artículos de diferentes tamaños y formas.
25. Antes de cargar, el gancho debe estar completamente colocado en el riel .



**Fabricante:** Shanghaimuxinmuyeyouxiangongsi

**Dirección:** Shuangchenglu 803nong11hao1602A-1609shi, baoshanqu, shanghai 200000 CN.

**Importado a AUS:** SIHAO PTY LTD, 1 ROKEVA STREETEASTWOOD NSW 2122 Australia

**Importado a EE. UU.:** Sanven Technology Ltd., Suite 250, 9166 Anaheim Place, Rancho Cucamonga, CA 91730

<b>EC</b>	<b>REP</b>
-----------	------------

E-CrossStu GmbH  
Mainzer Landstr.69, 60329 Frankfurt am Main.

<b>UK</b>	<b>REP</b>
-----------	------------

YH CONSULTING LIMITED.  
C/O YH Consulting Limited Office 147, Centurion House,  
London Road, Staines-upon-Thames, Surrey, TW18 4AX



**VEVOR<sup>®</sup>**

**TOUGH TOOLS, HALF PRICE**

**Técnico Certificado de soporte y garantía electrónica**

**[www.vevor.com/support](http://www.vevor.com/support)**

# **VEVOR<sup>®</sup>**

**TOUGH TOOLS, HALF PRICE**

Techniczny Wsparcie i certyfikat e-gwarancji

[www.vevor.com/support](http://www.vevor.com/support)

## **ORGANIZER NA ELEKTRONARZĘDZIA INSTRUKCJA OBSŁUGI**

We continue to be committed to provide you tools with competitive price.

"Save Half", "Half Price" or any other similar expressions used by us only represents an estimate of savings you might benefit from buying certain tools with us compared to the major top brands and does not necessarily mean to cover all categories of tools offered by us. You are kindly reminded to verify carefully when you are placing an order with us if you are actually saving half in comparison with the top major brands.

# VEVOR<sup>®</sup>

TOUGH TOOLS, HALF PRICE

## POWER TOOL ORGANIZER

Model: JC-PTO-001; JC-PTO-002; JC-PTO-003; JC-PTO-004; JC-PTO-005

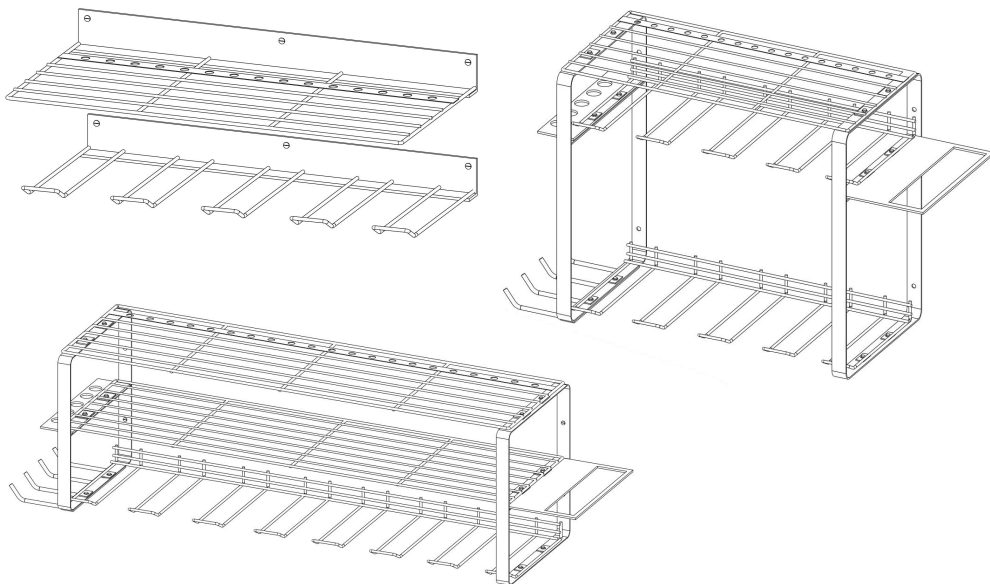

### NEED HELP? CONTACT US!

Have product questions? Need technical support? Please feel free to contact us:

**Technical Support and E-Warranty Certificate**  
**[www.vevor.com/support](http://www.vevor.com/support)**

This is the original instruction, please read all manual instructions carefully before operating. VEVOR reserves a clear interpretation of our user manual. The appearance of the product shall be subject to the product you received. Please forgive us that we won't inform you again if there are any technology or software updates on our product.

## 46. WARNING!

41. Przed instalacją upewnij się, że nie ma ryzyka przebicia ukrytych kabli prądowych lub rur wodnych. W razie wątpliwości użyj cyfrowego urządzenia śledzącego lub skonsultuj się z ekspertem.
42. Szyne należy zamontować na stabilnej powierzchni. Nie przeciążać.
43. Montaż uchwyty ściennego powinna wykonać osoba dorosła. Dzieci nie powinny używać uchwytu bez nadzoru.
44. Zalecany wyłącznie do cegły i betonu. W przypadku montażu na płytach gipsowo-kartonowych i innych podłożach należy stosować specjalne elementy mocujące.
45. organizera na elektronarzędzia należy dokładnie przeczytać i zrozumieć wszystkie ostrzeżenia i instrukcje dotyczące bezpieczeństwa.
46. Upewnij się, że organizer na elektronarzędzia jest zamontowany na stabilnej ścianie, aby zapobiec organizer elektronarzędzi i narzędzi przed upadkiem.
47. Proszę nie przekraczać maksymalnego dopuszczalnego obciążenia organizer narzędzi elektrycznych zapobiegający uszkodzeniom organizer elektronarzędzi i narzędzi przed upadkiem.
48. Proszę okresowo sprawdzać stabilność uchwytu narzędzia i bezpieczeństwo narzędzi .

## 47. Maintenance Guide

16. organizer narzędzi, aby zapobiec gromadzeniu się kurzu i brudu.
17. Sprawdź stabilność organizator elektronarzędzi, aby mieć pewność, że wszystkie elementy montażowe są bezpieczne i nieuszkodzone.
18. Sprawdź obciążenie organizator elektronarzędzi, aby mieć pewność, że maksymalny udźwig nie zostanie przekroczony.

## 48. Product Description

Organizer narzędzi elektrycznych jest organizatorem elektronarzędzi specjalnie zaprojektowane do przechowywania małych bezprzewodowych narzędzi do cięcia i montażu metalu (wiertarki elektryczne, wiertarki udarowe, elektryczne piły szablaste, wkrętarki elektryczne, klucze elektryczne itp.). Narzędzia elektryczne można zawiesić na dolnym gnieździe (w pozycji pionowej lub do góry nogami), a płaska warstwa może przechowywać baterie, małe skrzynki narzędziowe (z różnymi typami wiertel itp.) oraz nieco większe narzędzia (takie jak szlifierki kątowe i przecinarki elektryczne). Produkt jest głównie używany w garażach, warsztatach i narzędziowniach; otwór do przechowywania wkrętałów służy do umieszczania małych narzędzi ręcznych, takich jak wkrętaki i szczypce.

## 49. Product Parameter

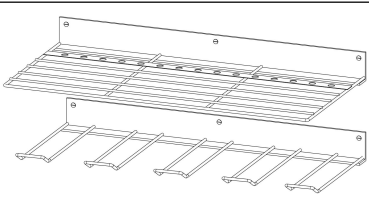
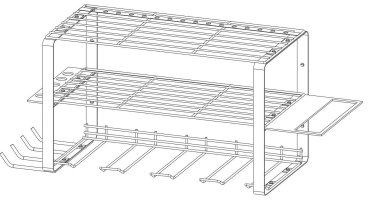
prze dmio t	Model	Zdjęcie	War stw y	Row ki	Półno cny Zach ód	GW	Rozmiar opakow ania
SKU 1	JC- PTO- 001		2	4	3,0 kg	3,3 kg	Wymiar y: 445*220 *86mm
SKU 2	JC- PTO- 002		3	4	2,3 kg	2,7 kg	430*227 *83mm

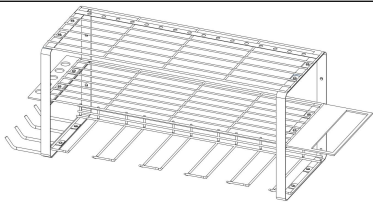
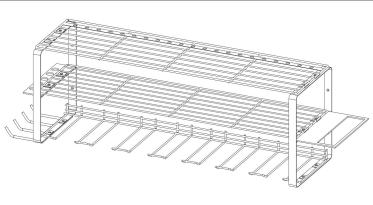
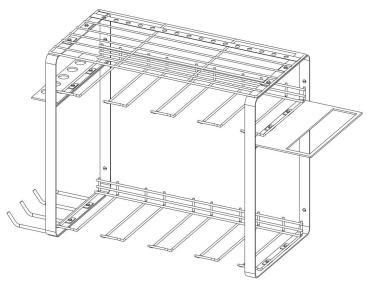



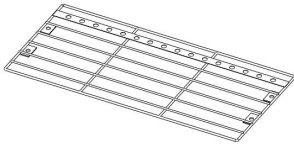

Num er katal og o g o w y 3	JC- PTO- 003		3	5	2,5 kg	3,0 kg	505*227 *85mm
SKU 4	JC- PTO- 004		3	7	3,0 kg	3,5 kg	655*225 *80mm
SKU 5	JC- PTO- 005		3	8	2,8 kg	3,2 kg	Wymiar y: 435*237 *115 mm

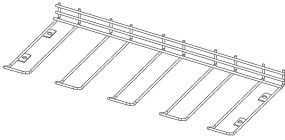
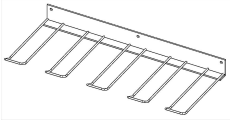
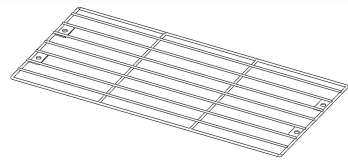
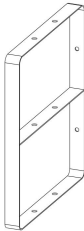
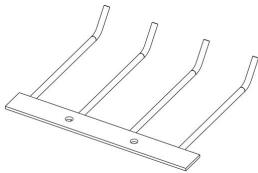
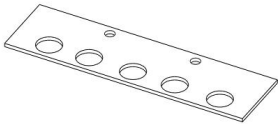
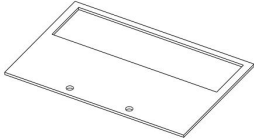
## 50. Part list

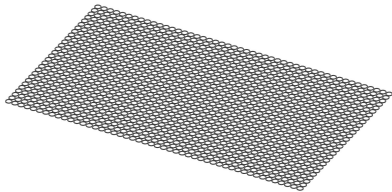
prze dmio t	Strony		Num er katalo gowy 1	SKU 2	Num er katal ogow y 3	SKU 4	SKU 5
			JC- PTO- 001	JC- PTO- 002	JC- PTO- 003	JC- PTO- 004	JC- PTO- 005
A		2 szt.		1 szt.	1 szt.	1 szt.	1 szt.



B	<p>Panel rowkowy</p> 	<p>2 szt. (4 rowki)</p> 	1 szt. (4 rowki )	1 szt. (5 rowków)	1 szt. (7 rowków)	2 szt. (4 rowki )
C	<p>Środkowy panel</p> 	/	1 szt.	1 szt.	1 szt.	/
D	<p>Nawias</p> 	/	2 szt.	2 szt.	2 szt.	2 szt.
mi	<p>Długi hak</p> 	/	1 szt.	1 szt.	1 szt.	1 szt.
F	<p>Uchwyt na szczypcę</p> 	/	1 szt.	1 szt.	1 szt.	1 szt.
G	<p>Uchwyt na młotek</p> 	/	1 szt.	1 szt.	1 szt.	1 szt.

H	<p>Mata antypoślizgowa</p> 	2 szt.	1 szt.	1 szt.	1 szt.	1 szt.
I	<p>Nakrętka</p> 	/	12 szt.	12 szt.	12 szt.	12 szt.
J	<p>Śruba</p> 	/	12 szt.	12 szt.	12 szt.	12 szt.
K	<p>Wkręt samogwintujący</p> 	12 szt.	4 szt.	4 szt.	4 szt.	4 szt.
L	<p>Kołki</p> 	12 szt.	4 szt.	4 szt.	4 szt.	4 szt.
M	<p>Klucz</p> 	/	1 szt.	1 szt.	1 szt.	1 szt.

## 51. Installation Guide for SKU1

Krok 1. Za pomocą części K (wkrętów samogwintujących ) i części L (kołków) przymocuj górny i dolny panel do ściany. Wysokość można ustalić losowo.

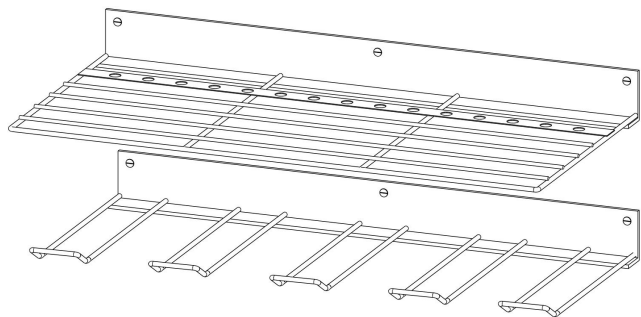

Część A i część B

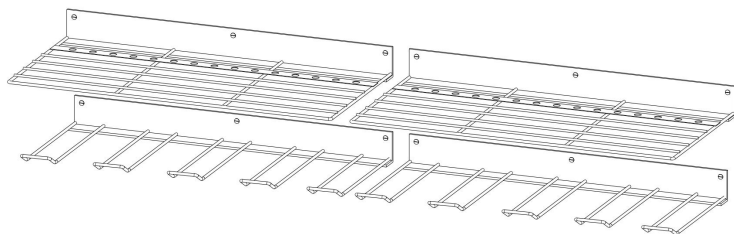

Część A i część B

B

Krok 2. Umieść część H (matę antypoślizgową) na części A.

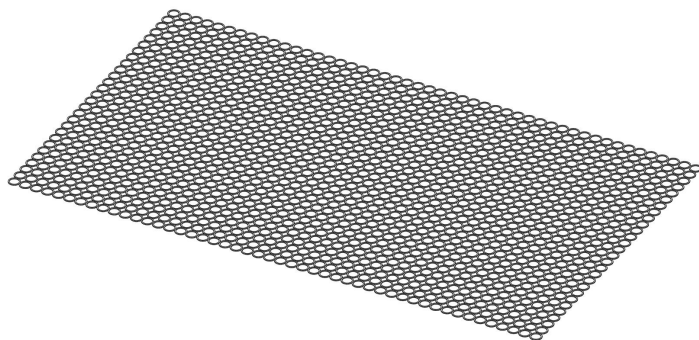

## 52. Installation Guide for SKU2 ~ SKU4

Krok 1. Jak pokazano na rysunku, zlokalizuj część D (wspornik) i umieść część B (panel rowkowy) i część E (długi hak) między dwoma panelami bocznymi. Użyj narzędzia Część M (klucz) wraz z elementami mocującymi Część J (śruba) i Część I (nakrętka), aby solidnie przymocować część B i

część E do części D.

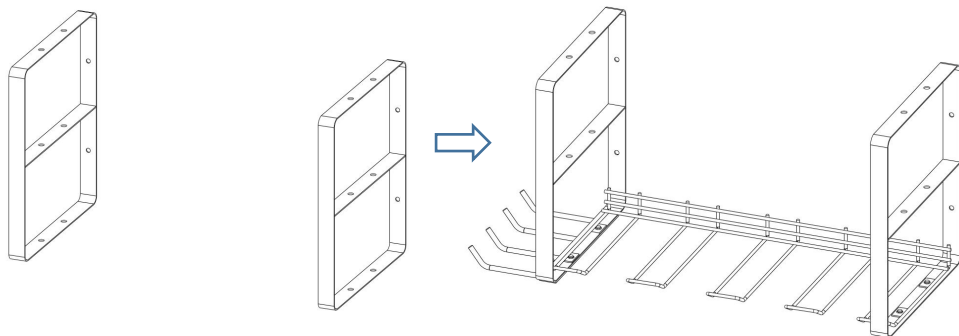

Część D Zainstaluj część B i część E

Krok 2. Umieść część G (uchwyt na młotek), część F (uchwyt na szczypce) i część C (panel środkowy) w środkowej warstwie części D (wspornik). Za pomocą narzędzia części M (klucz) wraz z elementami złącznymi części J (śruba) i części I (nakrętka) pewnie przymocuj je na miejscu.

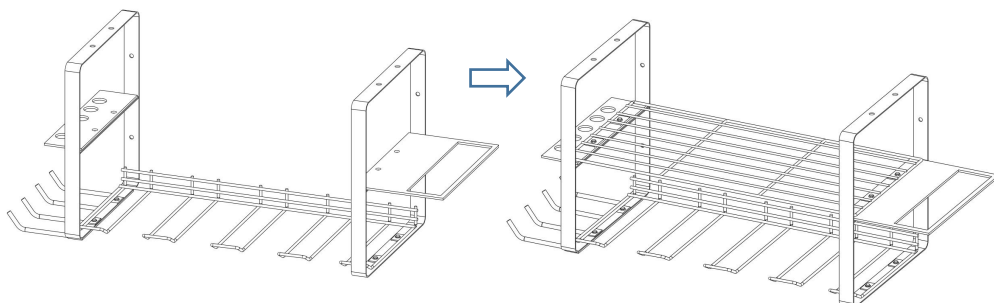

Zainstaluj część G i część F

Zainstaluj część C

Krok 3: Zainstaluj część A (panel narzędzi). Użyj narzędzia Część M (klucz) wraz z elementami mocującymi Część J (śruba) i Część I (nakrętka), aby solidnie przymocować ją na miejscu.

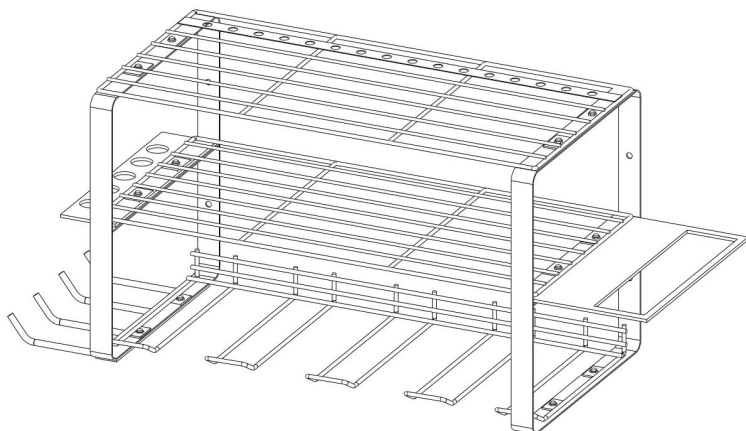

Zainstaluj część

A

Uwaga: Poniżej przedstawiono wygląd SKU2, SKU3 i SKU4 po zainstalowaniu panelu narzędzi.

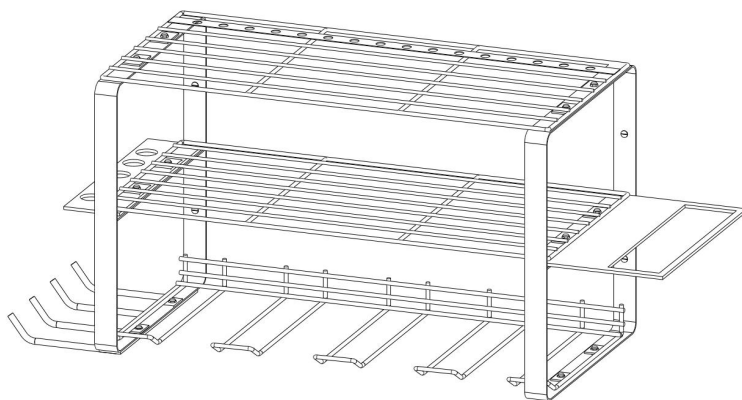

SKU2

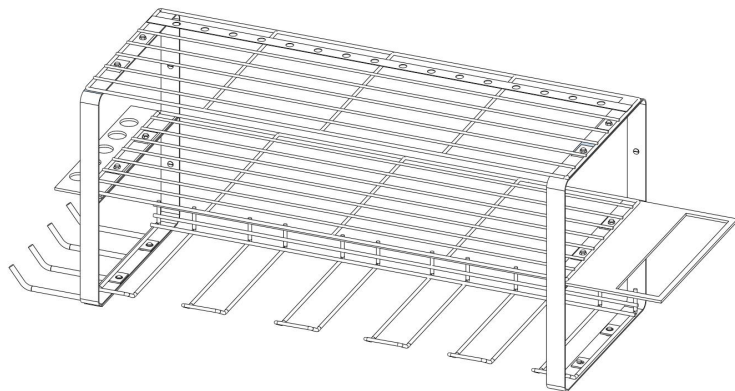

Numer

katalogowy 3

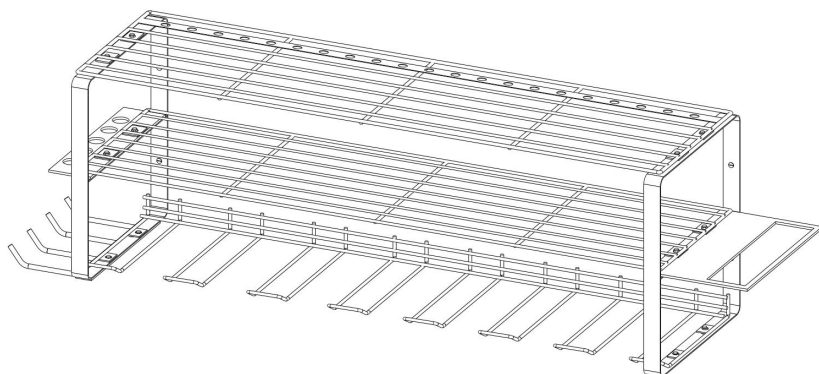

Numer

katalogowy 4

Krok 4: Za pomocą części K (wkrętów samogwintujących) i części L (kołków) pewnie zamocuj organizer na elektronarzędzia w wybranym miejscu na ścianie.

Krok 5: Umieść część H (matę antypoślizgową) na części A. Proces instalacji jest zakończony.

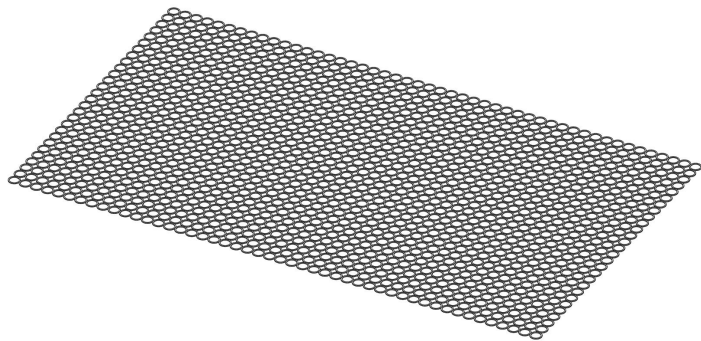

### 53. Installation Guide for SKU5

Krok 1. Jak pokazano na rysunku, zlokalizuj część D (wspornik) i umieść część B (panel rowkowy) i część E (długi hak) między dwoma panelami bocznymi. Użyj narzędzia Część M (klucz) wraz z elementami mocującymi Część J (śruba) i Część I (nakrętka), aby solidnie przymocować część B i część E do części D.

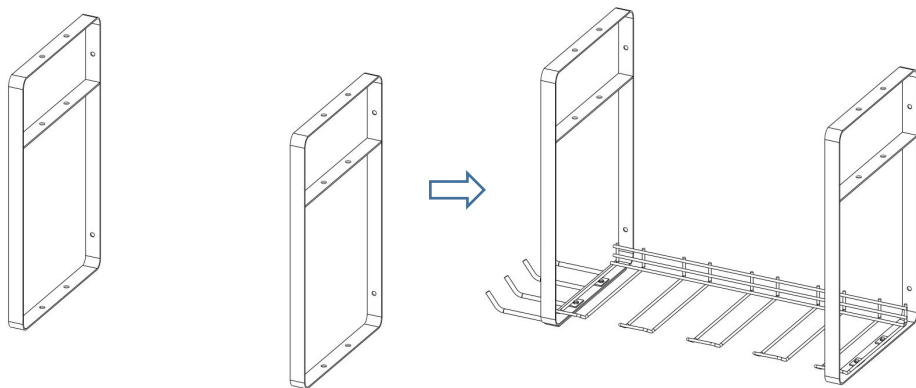

Znajdź część D Zainstaluj część B i część E

Krok 2. Umieść część G (uchwyt młotka), część F (uchwyt szczypiec) i część B (panel rowkowy) w środkowej warstwie części D (wspornik). Za pomocą narzędzia części M (klucz) wraz z elementami złącznymi części J (śruba) i części I (nakrętka) pewnie przymocuj je na miejscu.

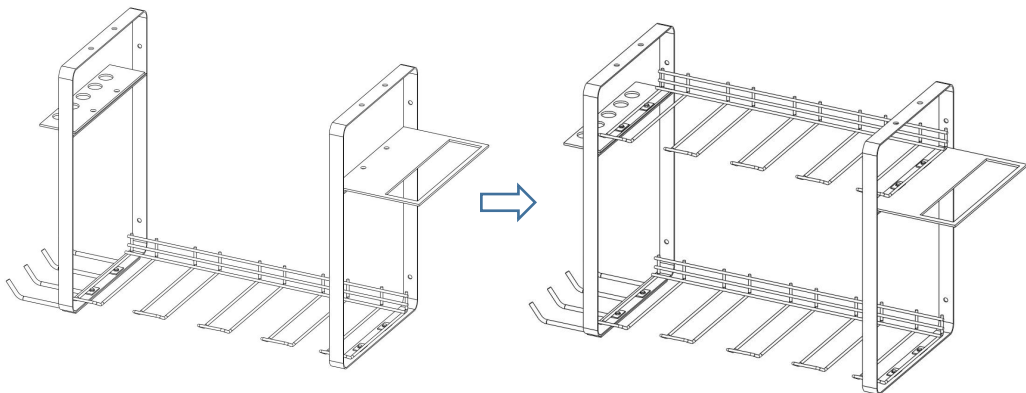

Zainstaluj część G i część F    Zainstaluj część B

Krok 3. Zainstaluj część A (panel narzędziowy). Użyj narzędzia Część M (klucz) wraz z elementami mocującymi Część J (śruba) i Część I (nakrętka), aby solidnie przymocować ją na miejscu.

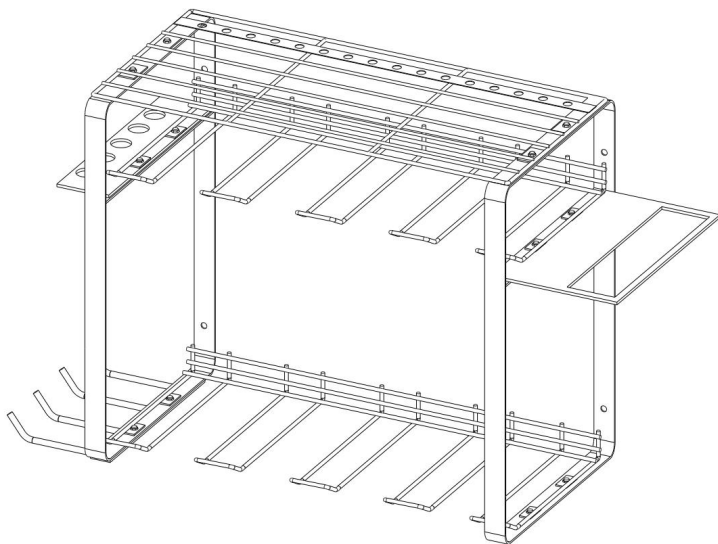

Krok 4: Za pomocą części K (wkrętów samogwintujących) i części L (kołków) pewnie zamocuj organizer na elektronarzędzia w wybranym miejscu na ścianie.



Krok 5: Umieść część H (matę antypoślizgową) na części A. Proces instalacji jest zakończony.

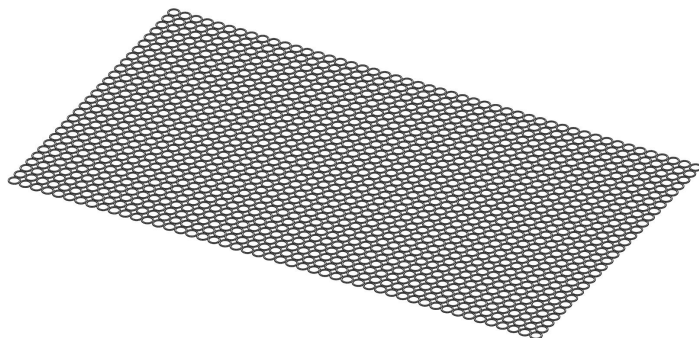

## 54. User Guide

26. Upewnij się, że przedmioty zawieszane na wieszaku nie przekraczają dopuszczalnego ciężaru.
27. Staraj się równomiernie rozłożyć ciężar na wieszaku i unikaj umieszczania go zbyt mocno po jednej stronie.
28. Nie wieszaj na wieszaku ostrych lub uszkodzonych przedmiotów, gdyż może to spowodować zarysowanie wieszaka lub obrażenia.
29. Dostosuj rozstaw haczyków w razie potrzeby, aby pomieścić przedmioty o różnych rozmiarach i kształtach.
30. Przed załadowaniem hak musi być całkowicie umieszczony na szynie .

**Producent:** Shanghaimuxinmuyeyouxiangongsi

**Adres:** Shuangchenglu 803nong11hao1602A-1609shi, baoshanqu, szanghaj 200000 CN.

**Importowane do AUS:** SIHAO PTY LTD, 1 ROKEVA STREETEASTWOOD NSW 2122 Australia

**Importowane do USA:** Sanven Technology Ltd., Suite 250, 9166 Anaheim Place, Rancho Cucamonga, CA 91730

<b>EC</b>	<b>REP</b>
-----------	------------

E-CrossStu GmbH  
Mainzer Landstr.69, 60329 Frankfurt am Main.

<b>UK</b>	<b>REP</b>
-----------	------------

YH CONSULTING LIMITED.  
C/O YH Consulting Limited Office 147, Centurion House,  
London Road, Staines-upon-Thames, Surrey, TW18 4AX



**VEVOR**<sup>®</sup>

**TOUGH TOOLS, HALF PRICE**

**Techniczny Wsparcie i certyfikat e-gwarancji**

**[www.vevor.com/support](http://www.vevor.com/support)**

# **VEVOR<sup>®</sup>**

**TOUGH TOOLS, HALF PRICE**

Technisch Ondersteuning en E-garantiecertificaat

[www.vevor.com/support](http://www.vevor.com/support)

## **ORGANISATOR VOOR ELEKTRISCH GEREEDSCHAP GEBRUIKERSHANDLEIDING**

We continue to be committed to provide you tools with competitive price.

"Save Half", "Half Price" or any other similar expressions used by us only represents an estimate of savings you might benefit from buying certain tools with us compared to the major top brands and does not necessarily mean to cover all categories of tools offered by us. You are kindly reminded to verify carefully when you are placing an order with us if you are actually saving half in comparison with the top major brands.



# VEVOR<sup>®</sup>

TOUGH TOOLS, HALF PRICE

## POWER TOOL ORGANIZER

Model: JC-PTO-001; JC-PTO-002; JC-PTO-003; JC-PTO-004; JC-PTO-005

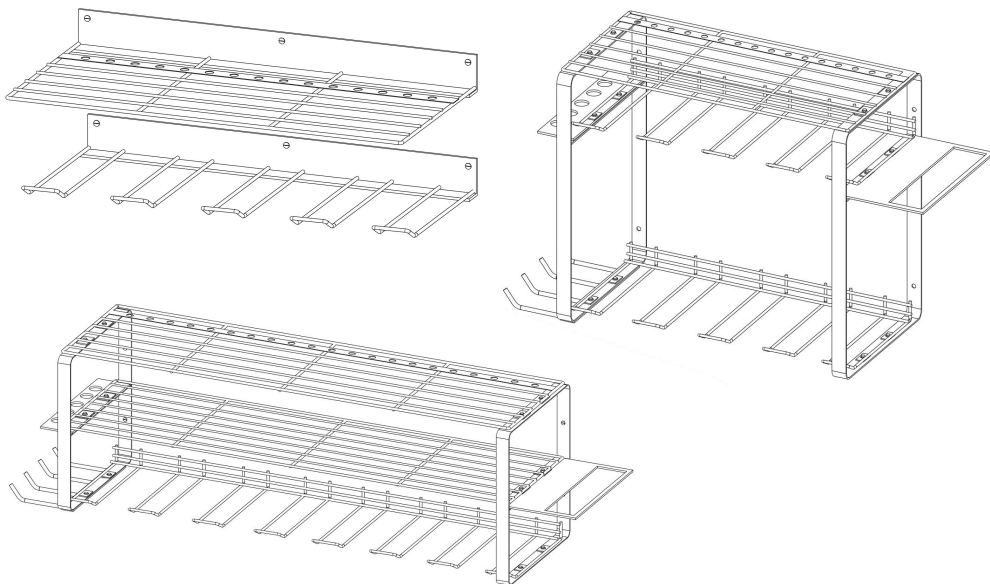

### NEED HELP? CONTACT US!

Have product questions? Need technical support? Please feel free to contact us:

**Technical Support and E-Warranty Certificate**  
[www.vevor.com/support](http://www.vevor.com/support)

This is the original instruction, please read all manual instructions carefully before operating. VEVOR reserves a clear interpretation of our user manual. The appearance of the product shall be subject to the product you received. Please forgive us that we won't inform you again if there are any technology or software updates on our product.

## **55. ⚠️WARNING!**

49. Controleer voor de installatie of er geen risico is dat verborgen stroomkabels of waterleidingen worden doorboord. Gebruik bij twijfel een digitaal volgapparaat of raadpleeg een expert.
50. De rail moet op een stabiele ondergrond worden gemonteerd. Niet overbelasten.
51. De montage van de muurbeugel dient door een volwassene te worden uitgevoerd. Kinderen mogen het apparaat niet zonder toezicht gebruiken.
52. Alleen aanbevolen voor baksteen en beton. Gebruik speciale bevestigingsmaterialen voor de installatie op gipsplaten of andere ondergronden.
53. Zorg ervoor dat u alle veiligheidswaarschuwingen en -instructies leest en begrijpt voordat u een organizer voor elektrisch gereedschap installeert en gebruikt .
54. Zorg ervoor dat de organizer voor elektrisch gereedschap aan een stabiele muur wordt gemonteerd om te voorkomen dat organizer voor elektrisch gereedschap en voorkomt dat gereedschap valt.
55. Overschrijd de maximale draagkracht van de organizer voor elektrisch gereedschap om schade aan de organizer voor elektrisch gereedschap en voorkomt dat gereedschap valt.
56. Controleer regelmatig de stabiliteit van de gereedschapshouder en de veiligheid van het gereedschap .

## **56. Maintenance Guide**

19. Maak de gereedschapsorganizer regelmatig schoon om ophoping van stof en vuil te voorkomen.



20. Controleer de stabiliteit van de organizer voor elektrisch gereedschap om ervoor te zorgen dat alle bevestigingsmaterialen veilig en onbeschadigd zijn.
21. Controleer de belasting van de organizer voor elektrisch gereedschap om ervoor te zorgen dat het maximale draagvermogen niet wordt overschreden.

## 57. Product Description

De organizer voor elektrisch gereedschap is een organizer voor elektrisch gereedschap speciaal ontworpen voor het opbergen van kleine snoerloze metaalsnij- en montagegereedschappen (elektrische boormachines, slagboormachines, elektrische reciprozagen, elektrische schroevendraaiers, elektrische sleutels, enz.). Elektrisch gereedschap kan aan de onderste gleuf worden gehangen (rechttop of ondersteboven), en de vlakke laag kan batterijen, kleine gereedschapskisten (met verschillende soorten boortjes, enz.) en iets grotere gereedschappen (zoals haakse slijpers en elektrische snijmachines) opbergen. Het product wordt voornamelijk gebruikt in garages, werkplaatsen en gereedschapskamers; het opberggat voor schroevendraaiers wordt gebruikt om kleine handgereedschappen zoals schroevendraaiers en tangen te plaatsen.

## 58. Product Parameter

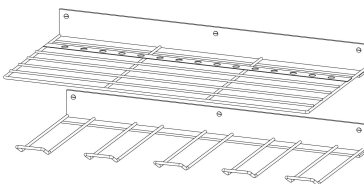
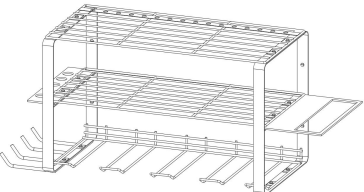

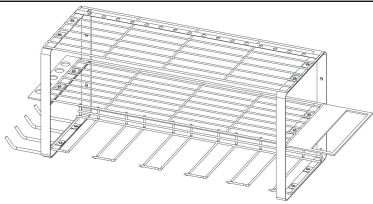
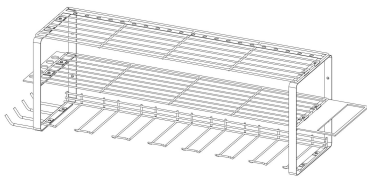
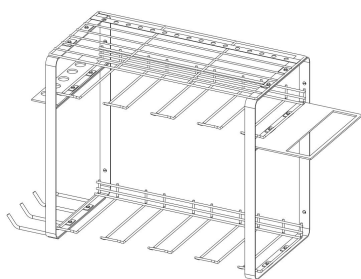

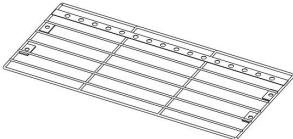
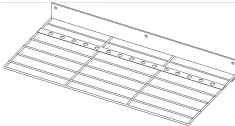

item	Model	Afbeelding	Lagen	Groeven	NW	GW	Verpakkingsgrootte
SKU 1	JC-PTO-001		2	4	3,0 kg	3,3 kg	445*220 *86mm
SKU 2	JC-PTO-002		3	4	2,3 kg	2,7 kg	430*227 *83mm

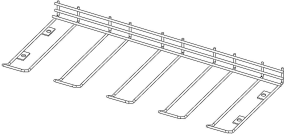
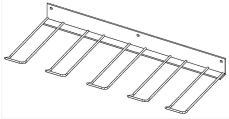
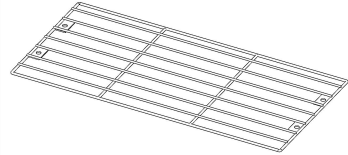
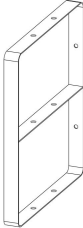
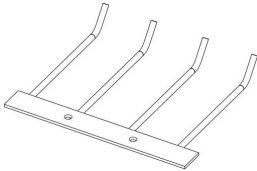
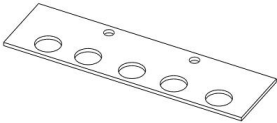
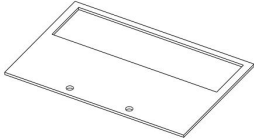
SKU 3	JC- PTO- 003		3	5	2,5 kg	3,0 kg	505*227 *85mm
SKU 4	JC- PTO- 004		3	7	3,0 kg	3,5 kg	655*225 *80mm
SKU 5	JC- PTO- 005		3	8	2,8 kg	3,2 kg	435*237 *115mm

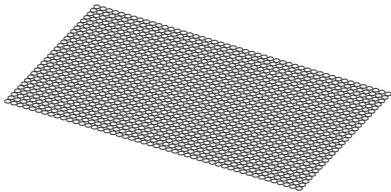
## 59. Part list

item	Onderdelen		SKU	SKU	SKU	SKU	SKU	
			1	2	3	4	5	
			JC- PTO- 001	JC- PTO- 002	JC- PTO- 003	JC- PTO- 004	JC- PTO- 005	
A	Gereedschapspaneel 	2 stuks 			1 stuks	1 stuks	1 stuks	1 stuks

B	<p>Groefpaneel</p> 	<p>2 stuks (4 groeven)</p> 	1 stuks (4 groeven)	1 stuks (5 groeven)	1 stuks (7 groeven)	2 stuks (4 groeven)
C	<p>Middenpaneel</p> 	/	1 stuks	1 stuks	1 stuks	/
D	<p>Beugel</p> 	/	2 stuks	2 stuks	2 stuks	2 stuks
Ik	<p>Lange haak</p> 	/	1 stuks	1 stuks	1 stuks	1 stuks
F	<p>Tangenhoder</p> 	/	1 stuks	1 stuks	1 stuks	1 stuks
G	<p>Hamerhouder</p> 	/	1 stuks	1 stuks	1 stuks	1 stuks

H	<p>Antislipmat</p> 	2 stuk	1 stuk	1 stuk	1 stuk	1 stuk
I	<p>Moer</p> 	/	12 stuk	12 stuk	12 stuk	12 stuk
J	<p>Schroef</p> 	/	12 stuk	12 stuk	12 stuk	12 stuk
Ik	<p>Zelftappende schroef</p> 	12 stuk	4 stuk	4 stuk	4 stuk	4 stuk
Ik	<p>Deuvels</p> 	12 stuk	4 stuk	4 stuk	4 stuk	4 stuk
M	<p>Moersleutel</p> 	/	1 stuk	1 stuk	1 stuk	1 stuk

## 60. Installation Guide for SKU1

Stap 1. Gebruik onderdeel K (zelftappende schroef ) en onderdeel L (pluggen) om de bovenste en onderste panelen aan de muur te bevestigen. De hoogte kan willekeurig worden bepaald.

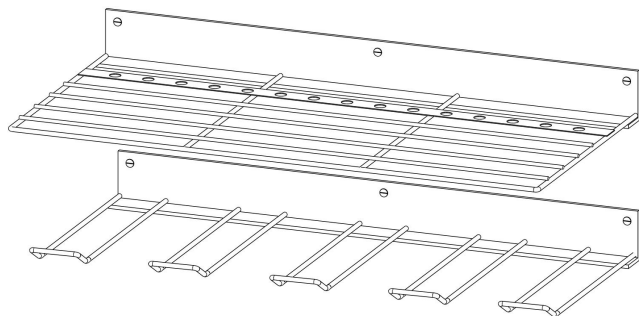

Deel A en Deel B

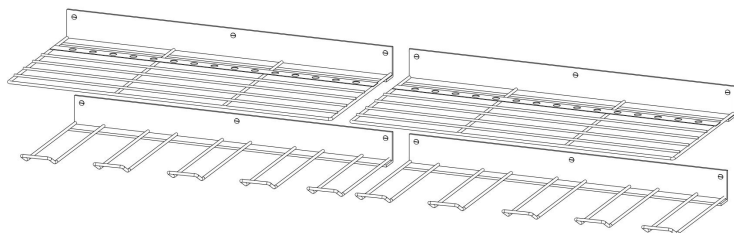

Deel A en Deel B

Stap 2. Plaats onderdeel H (antislipmat) op onderdeel A.

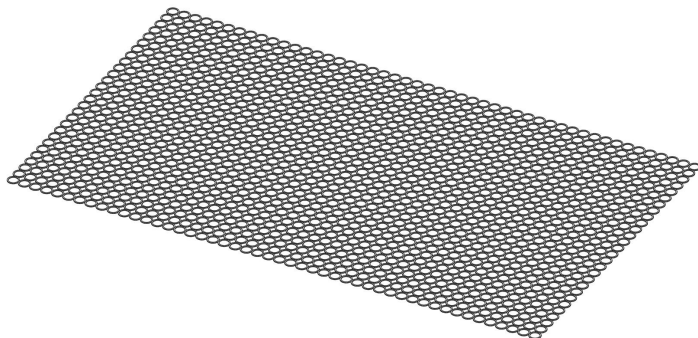

## 61. Installation Guide for SKU2 ~ SKU4

Stap 1. Zoals afgebeeld, lokaliseer onderdeel D (beugel) en plaats onderdeel B (groefpaneel) en onderdeel E (lange haak) tussen de twee zijpanelen. Gebruik het gereedschap onderdeel M (sleutel) samen met de bevestigingsmiddelen onderdeel J (schroef) en onderdeel I (moer) om onderdeel B en onderdeel E stevig vast te maken aan onderdeel D.

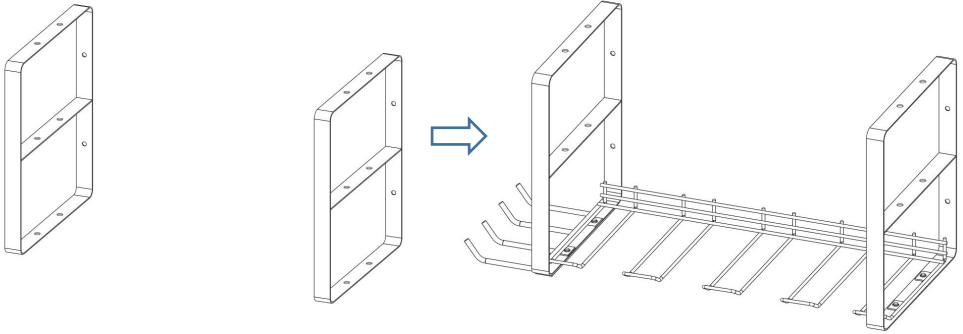

**Deel D** Installeer deel B en deel E

**Stap 2.** Plaats onderdeel G (hamerhouder), onderdeel F (tanghouder) en onderdeel C (middenpaneel) in de middelste laag van onderdeel D (beugel). Gebruik het gereedschap onderdeel M (sleutel) samen met de bevestigingsmiddelen onderdeel J (schroef) en onderdeel I (moer) om ze stevig vast te zetten.

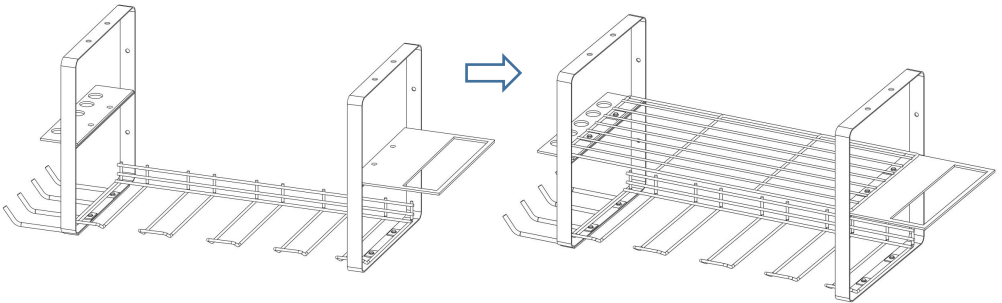

Installeer deel G en deel F

Deel C installeren

**Stap 3:** Installeer onderdeel A (gereedschapspaneel). Gebruik het gereedschap onderdeel M (sleutel) samen met de bevestigingsmiddelen onderdeel J (schroef) en onderdeel I (moer) om het stevig vast te zetten.

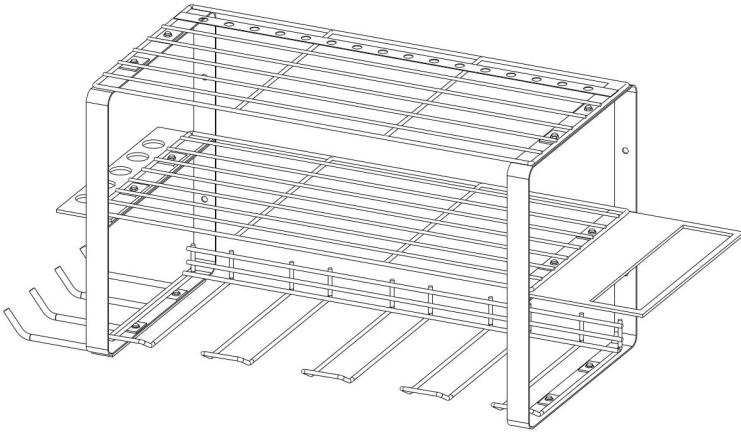

Deel A

installeren

Let op: Hieronder ziet u hoe SKU2, SKU3 en SKU4 eruitzien nadat u het gereedschapspaneel hebt geïnstalleerd.

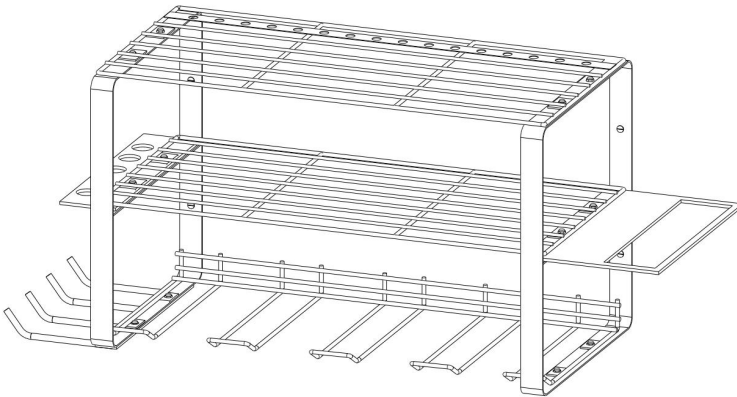

SKU2



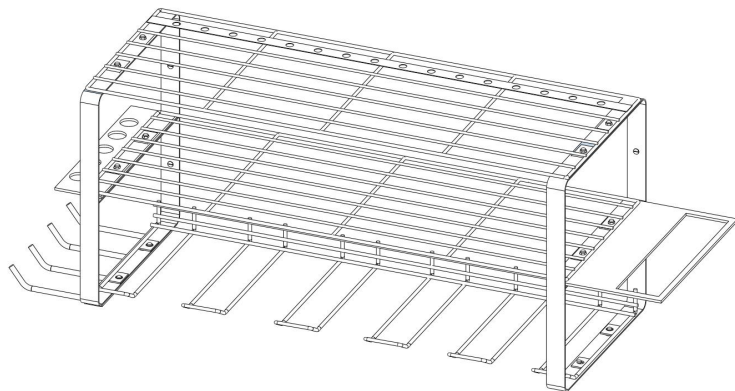

Artikelnummer3

Artikelnummer4

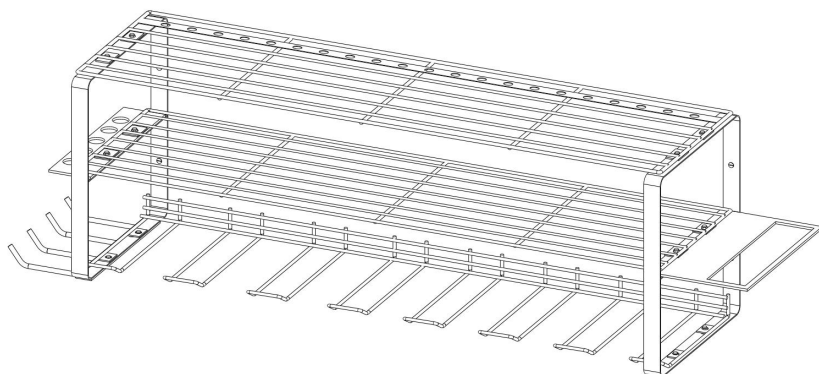

Stap 4: Gebruik onderdeel K (zelftappende schroef) en onderdeel L (pluggen) om de gereedschapsorganizer stevig op de gewenste plek aan de muur te bevestigen.

Stap 5: Plaats onderdeel H (antislipmat) op onderdeel A. Het installatieproces is voltooid.

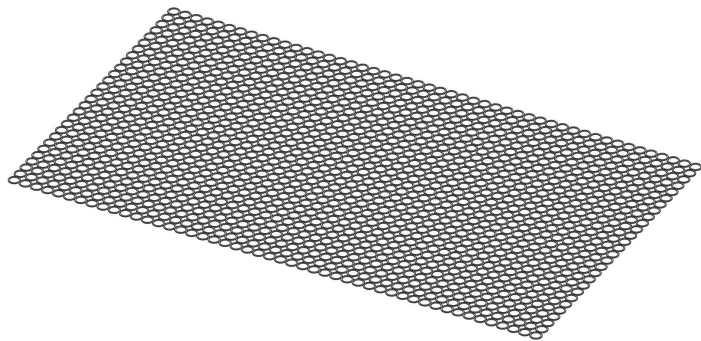

## 62. Installation Guide for SKU5

Stap 1. Zoals afgebeeld, lokaliseer onderdeel D (beugel) en plaats onderdeel B (groefpaneel) en onderdeel E (lange haak) tussen de twee zijpanelen. Gebruik het gereedschap onderdeel M (sleutel) samen met de bevestigingsmiddelen onderdeel J (schroef) en onderdeel I (moer) om onderdeel B en onderdeel E stevig vast te maken aan onderdeel D.

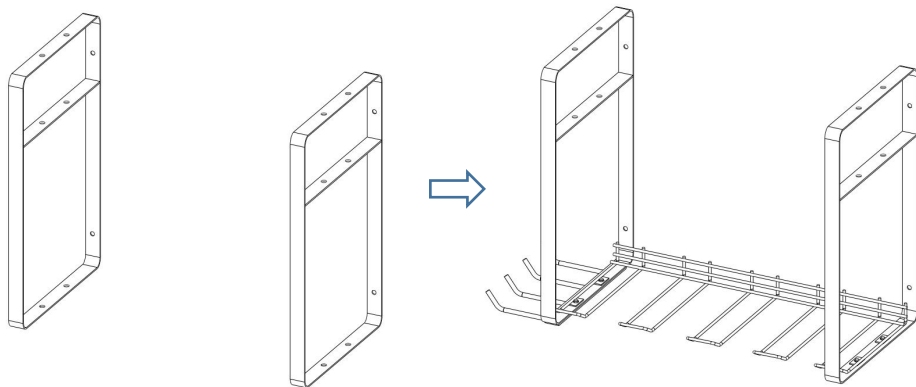

Vind Deel D Installeer deel B en deel E

Stap 2. Plaats onderdeel G (hamerhouder), onderdeel F (tanghouder) en onderdeel B (groefpaneel) in de middelste laag van onderdeel D (beugel). Gebruik het gereedschap onderdeel M (sleutel) samen met de bevestigingsmiddelen onderdeel J (schroef) en onderdeel I (moer) om ze stevig vast te zetten.

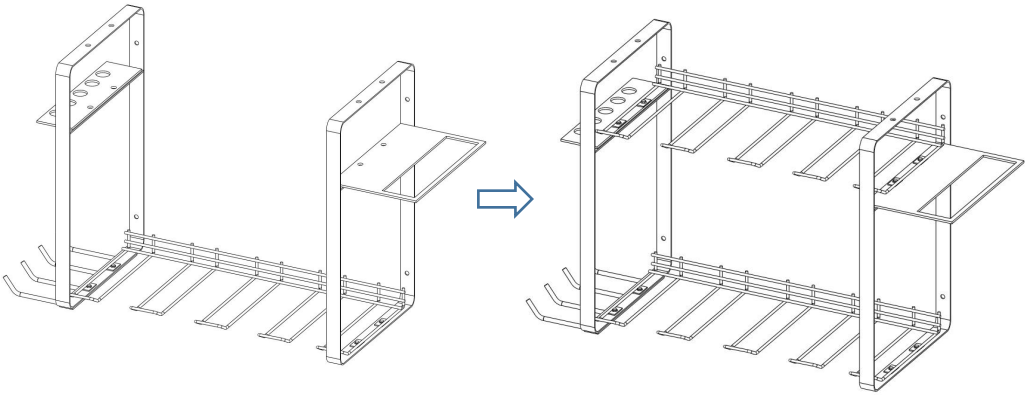

Installeer deel G en deel F Deel B installeren

Stap 3. Installeer onderdeel A (gereedschapspaneel). Gebruik het gereedschap onderdeel M (sleutel) samen met de bevestigingsmiddelen onderdeel J (schroef) en onderdeel I (moer) om het stevig vast te zetten.

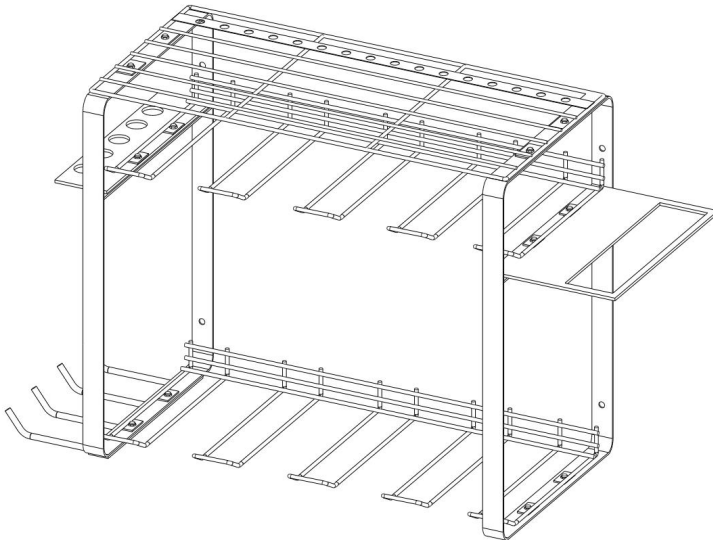

Stap 4: Gebruik onderdeel K (zelftappende schroef) en onderdeel L (pluggen) om de gereedschapsorganizer stevig op de gewenste plek aan de muur te bevestigen.

Stap 5: Plaats onderdeel H (antislipmat) op onderdeel A. Het installatieproces is voltooid.

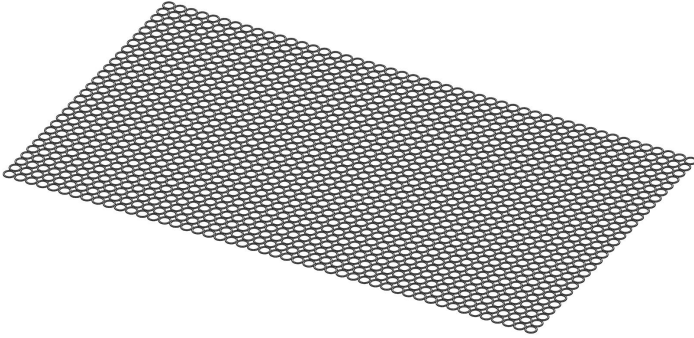

## 63. User Guide

31. Zorg ervoor dat de artikelen die u aan het rek hangt, niet zwaarder zijn dan het toegestane gewicht.
32. Probeer het gewicht gelijkmatig over de hanger te verdelen en zorg dat er niet te veel gewicht aan één kant hangt.
33. Hang geen scherpe of beschadigde voorwerpen aan de hanger. Dit kan krassen op de hanger veroorzaken of verwondingen veroorzaken.
34. Pas de afstand tussen de haken indien nodig aan om items van verschillende grootte en vorm op te hangen.
35. Voordat u gaat laden, moet de haak volledig op de rail worden geplaatst .

**Fabrikant:** Shanghaimuxinmuyeyouxiangongsi

**Adres:** Shuangchenglu 803nong11hao1602A-1609shi, baoshanqu, shanghai 200000 CN.

**Geïmporteerd naar AUS:** SIHAO PTY LTD, 1 ROKEVA STREETEASTWOOD NSW 2122 Australië

**Geïmporteerd naar de VS:** Sanven Technology Ltd., Suite 250, 9166 Anaheim Place, Rancho Cucamonga, CA 91730

<b>EC</b>	<b>REP</b>
-----------	------------

E-CrossStu GmbH  
Mainzer Landstr.69, 60329 Frankfurt am Main.

<b>UK</b>	<b>REP</b>
-----------	------------

YH CONSULTING LIMITED.  
C/O YH Consulting Limited Office 147, Centurion House,  
London Road, Staines-upon-Thames, Surrey, TW18 4AX



**VEVOR**<sup>®</sup>

**TOUGH TOOLS, HALF PRICE**

**Technisch Ondersteuning en E-garantiecertificaat**

**[www.vevor.com/support](http://www.vevor.com/support)**

# **VEVOR<sup>®</sup>**

**TOUGH TOOLS, HALF PRICE**

Teknisk Support och e-garanticertifikat

[www.vevor.com/support](http://www.vevor.com/support)

## **POWER TOOL ORGANIZER**

## **ANVÄNDARMANUAL**

We continue to be committed to provide you tools with competitive price.

"Save Half", "Half Price" or any other similar expressions used by us only represents an estimate of savings you might benefit from buying certain tools with us compared to the major top brands and does not necessarily mean to cover all categories of tools offered by us. You are kindly reminded to verify carefully when you are placing an order with us if you are actually saving half in comparison with the top major brands.



# VEVOR®

TOUGH TOOLS, HALF PRICE

## POWER TOOL ORGANIZER

Modell: JC-PTO-001; JC-PTO-002; JC-PTO-003; JC-PTO-004; JC-PTO-005

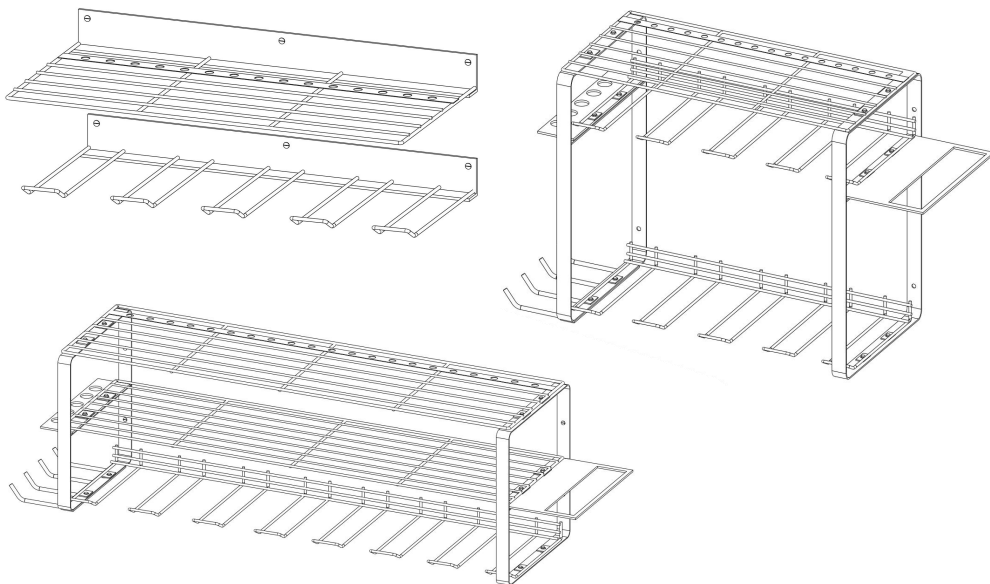

### NEED HELP? CONTACT US!

Have product questions? Need technical support? Please feel free to contact us:

**Technical Support and E-Warranty Certificate**  
[www.vevor.com/support](http://www.vevor.com/support)

This is the original instruction, please read all manual instructions carefully before operating. VEVOR reserves a clear interpretation of our user manual. The appearance of the product shall be subject to the product you received. Please forgive us that we won't inform you again if there are any technology or software updates on our product.

## 64. WARNING!

57. Innan installationen, se till att den inte riskerar att sticka hål på dolda strömkablar eller vattenledningar. Vid tveksamhet, använd en digital spårningsenhet eller rådfråga en expert.
58. Skenan ska monteras på ett stabilt underlag. Överbelasta inte.
59. Installationen av väggfästet bör göras av en vuxen, och barn bör inte använda det utan tillsyn.
60. Rekommenderas endast för tegel och betong; använd speciell hårdvara för att installera den på gipsskivor eller andra underlag.
61. Innan du installerar och använder en elverktygsorganisator ska du läsa och förstå alla säkerhetsvarningar och instruktioner.
62. Se till att verktygsfördelaren är installerad på en stabil vägg för att förhindra att elverktygsorganisatör och verktyg från att falla.
63. Vänligen överskrid inte den maximala lastkapaciteten för elverktygsorganisator för att förhindra skador på elverktygsorganisatör och verktyg från att falla.
64. Kontrollera regelbundet verktygshållarens stabilitet och säkerheten för verktygen .

## 65. Maintenance Guide

22. Rengör verktygsfördelaren regelbundet för att undvika ansamling av damm och smuts .
23. Kontrollera stabiliteten på elverktygsorganisator för att se till att all monteringsutrustning är säker och oskadad.
24. Kontrollera belastningen på elverktygsorganisator för att säkerställa att den maximala lastkapaciteten inte överskrids.

## 66. Product Description

Elverktygsarrangören är en elverktygsarrangör speciellt utformad för förvaring av små sladdlösa verktyg för skärande och montering av metall (elektriska borrar, slagborrar, elektriska kolvsågar, elektriska skruvmejslar, elektriska skiftnycklar, etc.). Elverktyg kan hängas på den nedre skåran (upprätt eller upp och ner), och det platta lagret kan förvara batterier, små verktygslådor (med olika typer av borr, etc.) och lite större verktyg (som vinkelslipar och el. skärare). Produkten används främst i garage, verkstäder och verktygsrum; skruvmejselns förvaringshåll används för att placera små manuella verktyg som skruvmejslar och tång.

## 67. Product Parameter

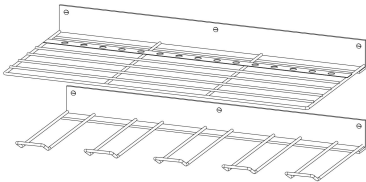
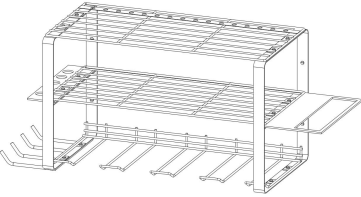
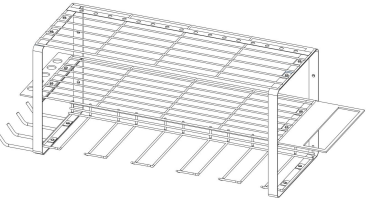

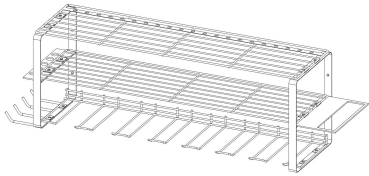
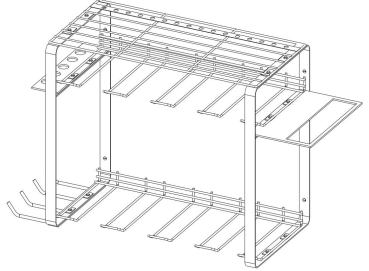

punkt	Model	Bild	Lager	Spår	NW	GW	Förpackningsstorlek
SKU 1	JC-PTO-001		2	4	3,0 kg	3,3 kg	445*220 *86mm
SKU 2	JC-PTO-002		3	4	2,3 kg	2,7 kg	430*227 *83mm
SKU 3	JC-PTO-003		3	5	2,5 kg	3,0 kg	505*227 *85mm

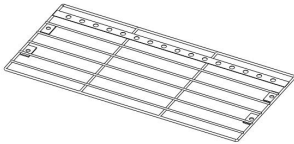
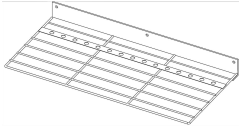
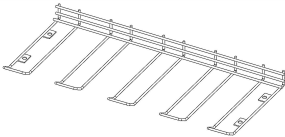
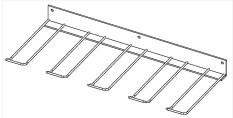
SKU 4	JC- PTO- 004		3	7	3,0 kg	3,5 kg	655*225 *80mm
SKU 5	JC- PTO- 005		3	8	2,8 kg	3,2 kg	435*237 *115mm

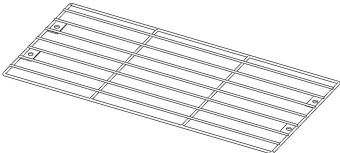
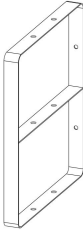
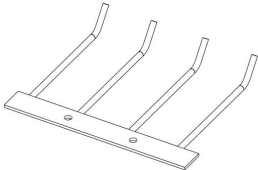
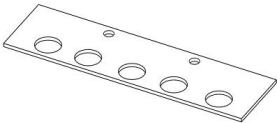
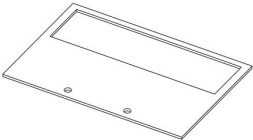
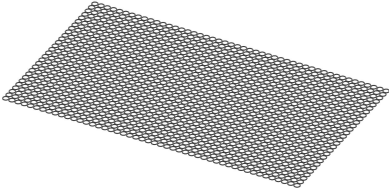
## 68. Part list

punkt	Delar		SKU	SKU	SKU	SKU	SKU
			1	2	3	4	5
			JC- PTO- 001	JC- PTO- 002	JC- PTO- 003	JC- PTO- 004	JC- PTO- 005
A	Verktygspanel 	2 st 	1 st	1 st	1 st	1 st	1 st
B	Spårpanel 	2 st (4 spår) 	1 st	1 st (4 spår)	1 st (5 spår)	1 st (7 spår)	2 st (4 spår)

C	<p>Mittpanel</p> 	/	1 st	1 st	1 st	/
D	<p>Konsol</p> 	/	2 st	2 st	2 st	2 st
E	<p>Lång krok</p> 	/	1 st	1 st	1 st	1 st
F	<p>Tånghållare</p> 	/	1 st	1 st	1 st	1 st
G	<p>Hammarhållare</p> 	/	1 st	1 st	1 st	1 st
H	<p>Anti-halk matta</p> 	2 st	1 st	1 st	1 st	1 st

jag	Mutter 	/	12 st	12 st	12 st	12 st
J	Skruva 	/	12 st	12 st	12 st	12 st
K	Självgängande skruv 	12 st	4 st	4 st	4 st	4 st
L	Pluggar 	12 st	4 st	4 st	4 st	4 st
M	Rycka 	/	1 st	1 st	1 st	1 st

## 69. Installation Guide for SKU1

Steg 1. Använd del K (självgängande skruv ) och del L (tappar) för att fästa de övre och nedre panelerna på väggen, och höjden kan definieras slumpmässigt.

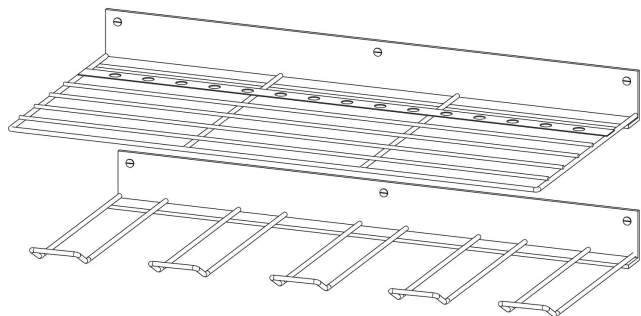

Del A och del B

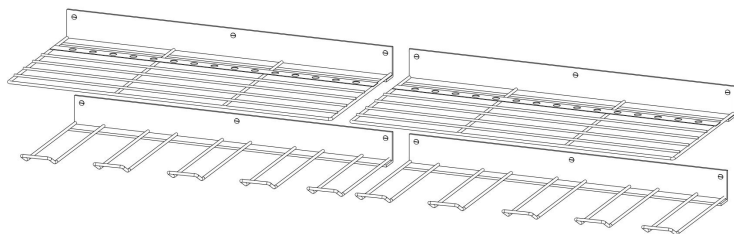

Del A och del B

Steg 2. Lägg del H (Anti-slip matta) ovanpå del A.

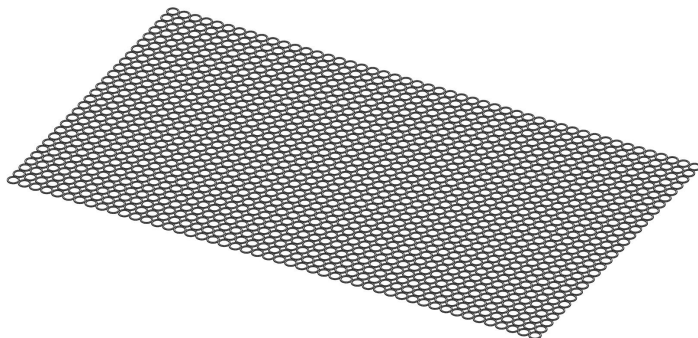

## 70. Installation Guide for SKU2 ~ SKU4

Steg 1. Som visas på bilden, lokalisera del D (fäste) och placera del B (spårpanel) och del E (lång krok) mellan de två sidopanelerna. Använd verktyget Del M (nyckel) tillsammans med fästelementen Del J (Skruva) och Del I (Mutter) för att säkert fästa Del B och Del E på Del D.

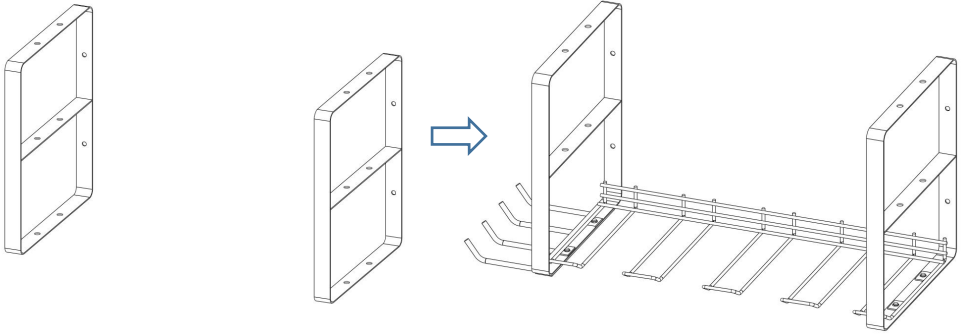

**Del D**      Installera del B och del E

**Steg 2.** Placera del G (hammarhållare), del F (tånghållare) och del C (mittpanel) i mitten av t del D (fäste), använd verktyget del M (nyckel) tillsammans med fästelementen del J (skruv) och del I (mutter) för att säkert fästa dem på plats.

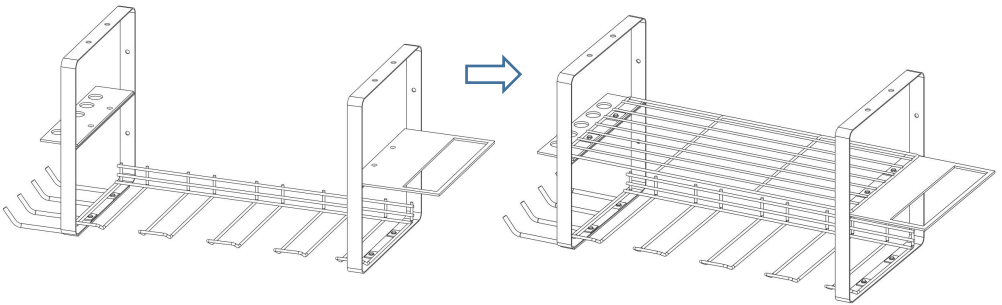

Installera del G och del F

Installera del C

**Steg 3:** Installera del A (verktygspanel). Använd verktyget Del M (nyckel) tillsammans med fästelementen Del J (Skruva) och Del I (Mutter) för att säkert fästa det på plats.



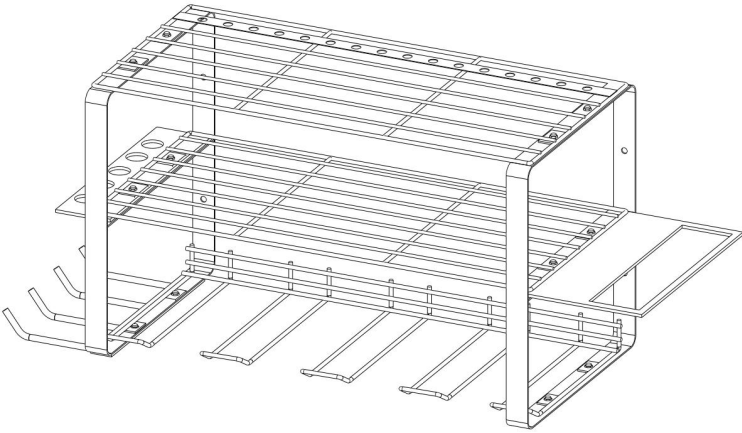

Installera del A

Obs: Nedan ser du hur SKU2, SKU3 och SKU4 ser ut efter installation av verktygspanelen.

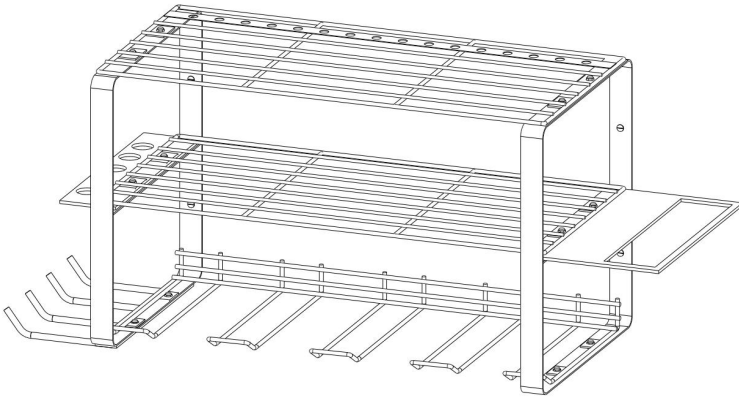

SKU2

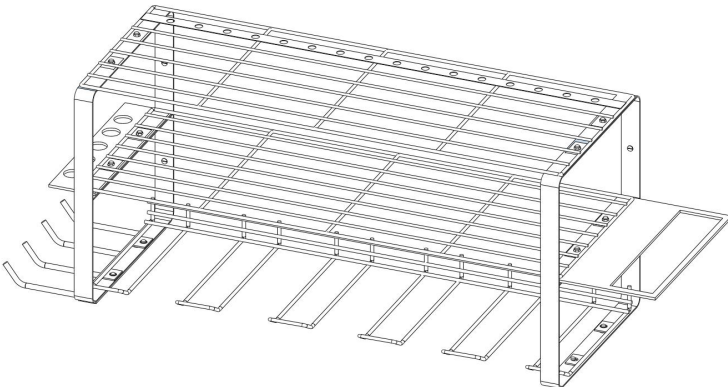

SKU3

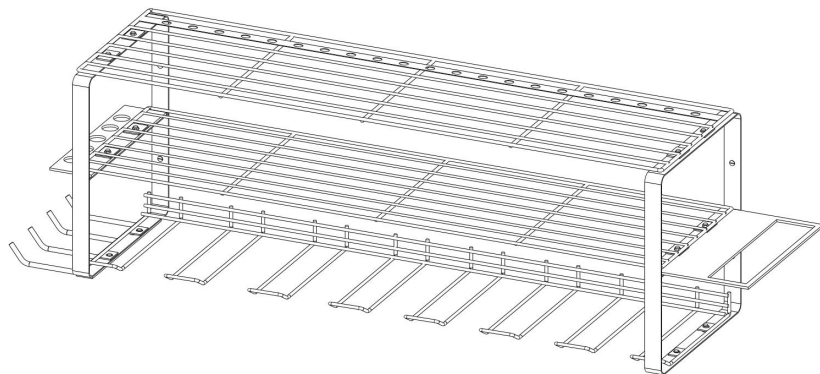

SKU4

Steg 4: Använd del K (självgångande skruv) och del L (tappar) för att säkert fästa verktygsverktyget på önskad plats på väggen.

Steg 5: Placera del H (anti-halkmatta) ovanpå del A. Installationsprocessen är klar.

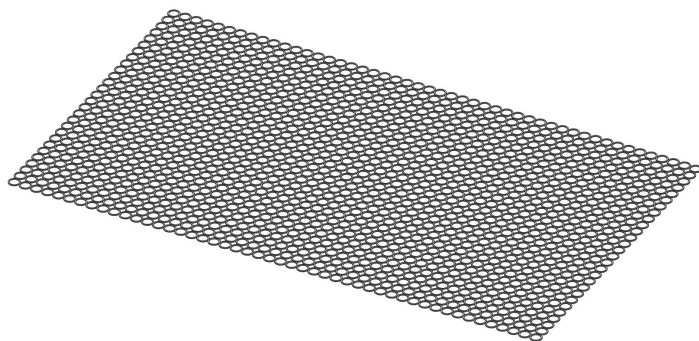

## 71. Installation Guide for SKU5

Steg 1. Som visas på bilden, lokalisera del D (fäste) och placera del B (spårpanel) och del E (lång krok) mellan de två sidopanelerna. Använd verktyget Del M (nyckel) tillsammans med fästelementen Del J (Skruva) och Del I (Mutter) för att säkert fästa Del B och Del E på Del D.

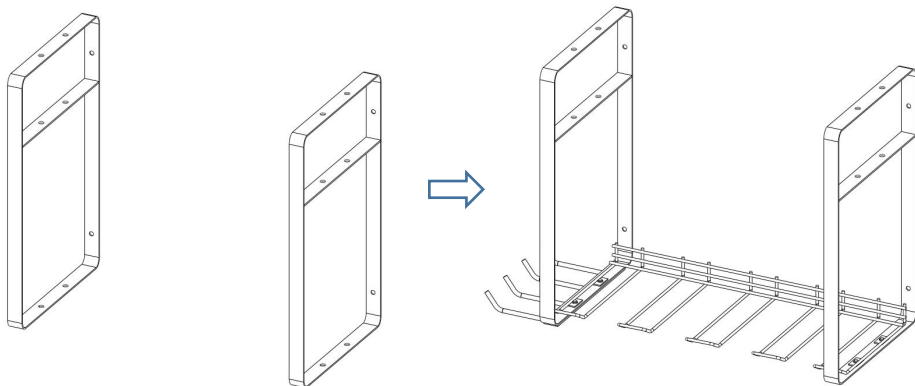

Hitta del D Installera del B och del E

Steg 2. Placera del G (hammarhållare), del F (tånghållare) och del B (spårpanel) i mittskiktet av del D (fäste), använd verktyget del M (nyckel) tillsammans med fästelementen del J (skruv) och del I (mutter) för att säkert fästa dem på plats.

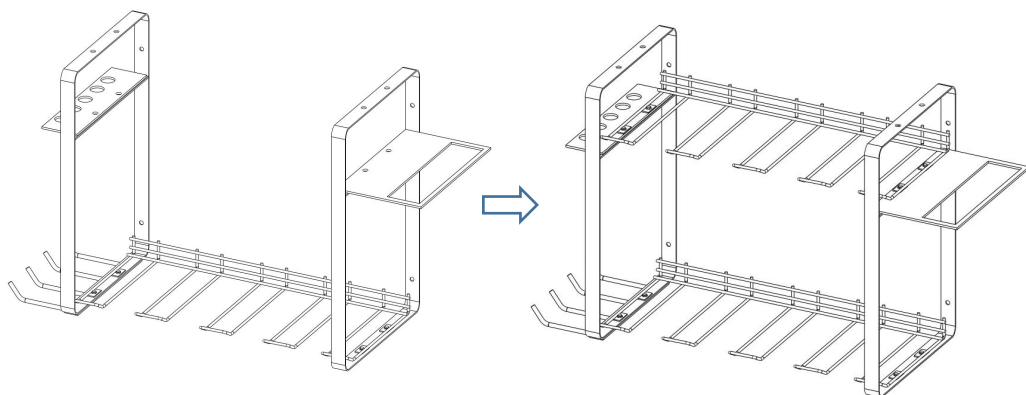

Installera del G och del F    Installera del B

Steg 3. Installera del A (verktygspanel). Använd verktyget Del M (nyckel) tillsammans med fästelementen Del J (Skruva) och Del I (Mutter) för att säkert fästa det på plats.

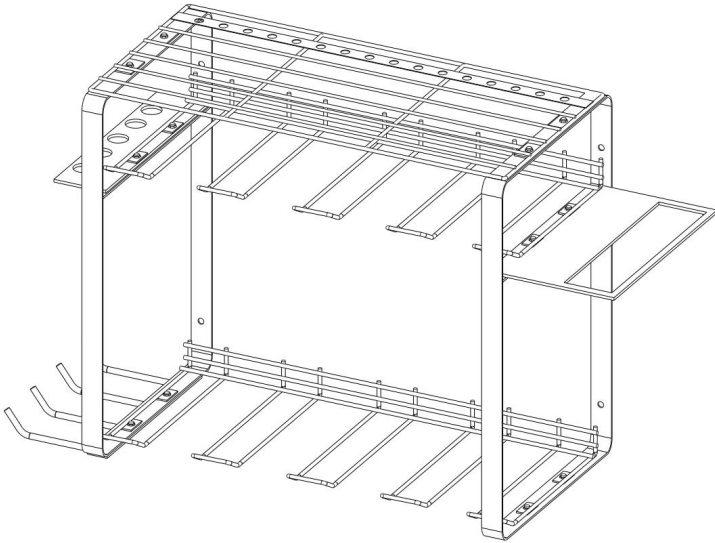

Steg 4: Använd del K (självgående skruv) och del L (tappar) för att säkert fästa verktygsverket på önskad plats på väggen.

Steg 5: Placera del H (anti-halkmatta) ovanpå del A. Installationsprocessen är klar.

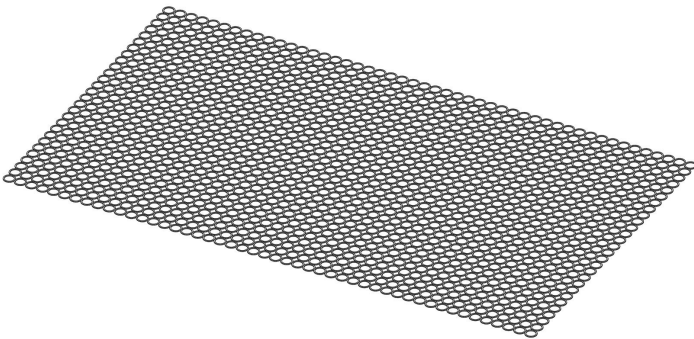

## 72. User Guide

36. Se till att föremål som hängs på stativet inte överskrider deras viktgräns.
37. Försök att fördela vikten på galgen jämnt och undvik att vara för tung på ena sidan.
38. Häng inte vassa eller skadade föremål på hängaren, eftersom det kan repa hängaren eller orsaka skada.
39. Justera avståndet mellan krokarna efter behov för att rymma föremål av olika storlekar och former.
40. Före lastning måste kroken vara helt placerad på skenan .

**Tillverkare:** Shanghaimuxinmuyeyouxiangongsi

**Address:** Shuangchenglu 803nong11hao1602A-1609shi, baoshanqu, shanghai 200000 CN.

**Importerad till AUS:** SIHAO PTY LTD, 1 ROKEVA STREETEASTWOOD NSW 2122 Australien

**Importerad till USA:** Sanven Technology Ltd., Suite 250, 9166 Anaheim Place, Rancho Cucamonga, CA 91730

<b>EC</b>	<b>REP</b>
-----------	------------

E-CrossStu GmbH  
Mainzer Landstr.69, 60329 Frankfurt am Main.

<b>UK</b>	<b>REP</b>
-----------	------------

YH CONSULTING LIMITED.  
C/O YH Consulting Limited Office 147, Centurion House,  
London Road, Staines-upon-Thames, Surrey, TW18 4AX



**VEVOR**<sup>®</sup>

**TOUGH TOOLS, HALF PRICE**

**Teknisk Support och e-garanticertifikat**

**[www.vevor.com/support](http://www.vevor.com/support)**