

# **VEVOR**

**Affordable. Reliable. Home Improvement.**

## **HACK SQUAT MACHINE**

**MODEL:HM2901A**

# VEVOR

Affordable. Reliable. Home Improvement.

## HACK SQUAT MACHINE

MODEL:HM2901A

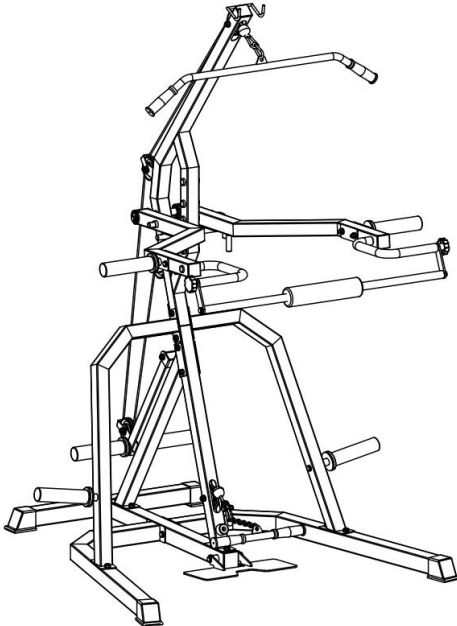

### Installation Instruction



This is the original instruction, please read all manual instructions carefully before operating. VEVOR reserves a clear interpretation of our user manual. The appearance of the product shall be subject to the product you received. Please forgive us that we won't inform you again if there are any technology or software updates on our product.





Warning-To reduce the risk of injury, user must read instructions manual carefully.





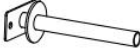



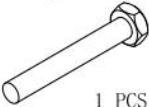
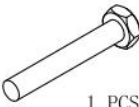

## PRE-ASSEMBLY CHECKLIST

**Make sure include all parts before starting assembly.**

Noted: Some screw accessories have been installed on the product and need to be loosened and then connected.









PARTS LIST				
A  1PCS	B  1PCS	C  1PCS	D  1PCS	E  1PCS
F  1PCS	G  1PCS	H  1PCS	I  6PCS	J  2PCS
K  5 PCS	L  1PCS	M  1PCS	N  2PCS	O  1 PCS
P  1 PCS	Q  1PCS	R  1 PCS	S  2 PCS	T  2 PCS
U  1PCS	V  2PCS	W  2 PCS	X1  1 PCS	X2  1 PCS
Y1  1 PCS	Y2  1 PCS	Y3  3 PCS	Y4  1 PCS	Z  1 PCS

# HARDWARE LIST

<p>1. BOLT (M10×135)</p>  <p style="text-align: center;">1 PCS</p>	<p>2. BOLT (M10×100)</p>  <p style="text-align: center;">1 PCS</p>	<p>3. BOLT (M10×80)</p>  <p style="text-align: center;">4 PCS</p>	<p>4. BOLT (M10×70)</p>  <p style="text-align: center;">10 PCS</p>	<p>5. BOLT (M10×50)</p>  <p style="text-align: center;">3 PCS</p>
<p>6. BOLT (M10×20)</p>  <p style="text-align: center;">8 PCS</p>	<p>7. Spacer Sleeve (10)</p>  <p style="text-align: center;">4 PCS</p>	<p>8. Carriage BOLT (M10×75)</p>  <p style="text-align: center;">8 PCS</p>	<p>9. BOLT (M8×16)</p>  <p style="text-align: center;">2 PCS</p>	<p>10. Washer (M10)</p>  <p style="text-align: center;">52 PCS</p>
<p>11. Big Washer (M10)</p>  <p style="text-align: center;">2 PCS</p>	<p>12. Locknut (M10)</p>  <p style="text-align: center;">27 PCS</p>			







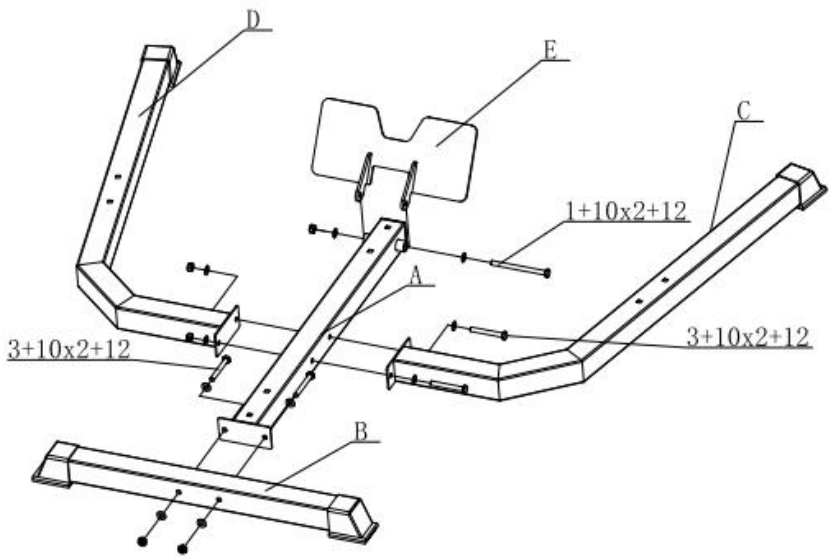

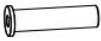

# ASSEMBLY INSTRUCTIONS

**STEP 1:**

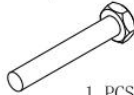
<p>A</p>  <p style="text-align: center;">1PCS</p>	<p>B</p>  <p style="text-align: center;">1PCS</p>	<p>C</p>  <p style="text-align: center;">1PCS</p>	<p>D</p>  <p style="text-align: center;">1PCS</p>	<p>E</p>  <p style="text-align: center;">4PCS</p>
<p>1. BOLT (M10 × 135)</p>  <p style="text-align: center;">1 PCS</p>	<p>3. BOLT (M10 × 80)</p>  <p style="text-align: center;">4 PCS</p>	<p>10. Washer (M10)</p>  <p style="text-align: center;">10 PCS</p>	<p>12. Locknut (M10)</p>  <p style="text-align: center;">5 PCS</p>	







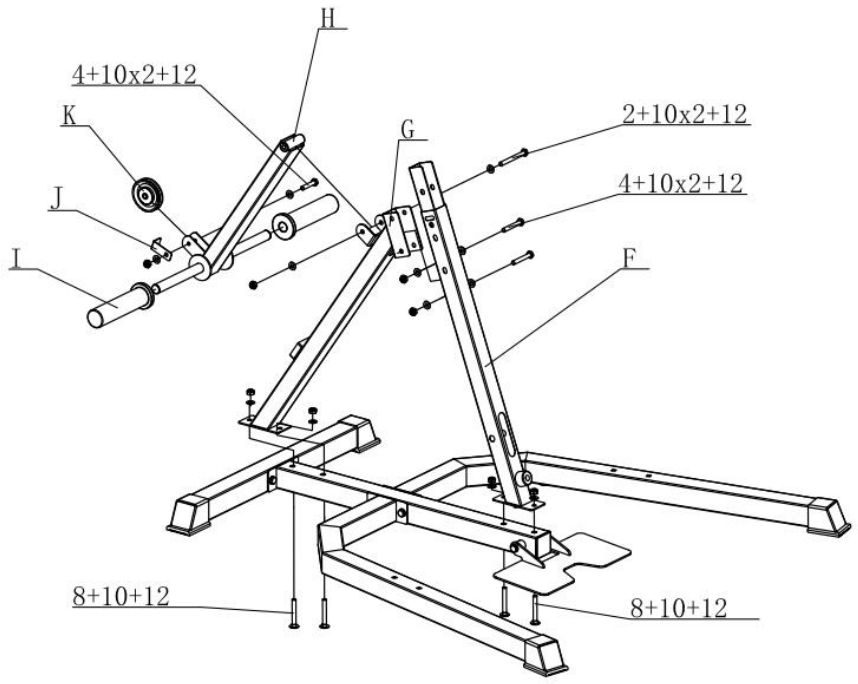

  

# STEP2:

<p>F</p>  <p>1PCS</p>	<p>G</p>  <p>1PCS</p>	<p>H</p>  <p>1PCS</p>	<p>I</p>  <p>2PCS</p>	<p>J</p>  <p>1PCS</p>
<p>K</p>  <p>1 PCS</p>	<p>2. BOLT (M10×100)</p>  <p>1 PCS</p>	<p>4. BOLT (M10×70)</p>  <p>2 PCS</p>	<p>5. BOLT (M10×50)</p>  <p>1 PCS</p>	<p>8. Carriage BOLT (M10×75)</p>  <p>4 PCS</p>
<p>10. Washer (M10)</p>  <p>12 PCS</p>	<p>12. Locknut (M10)</p>  <p>8 PCS</p>			







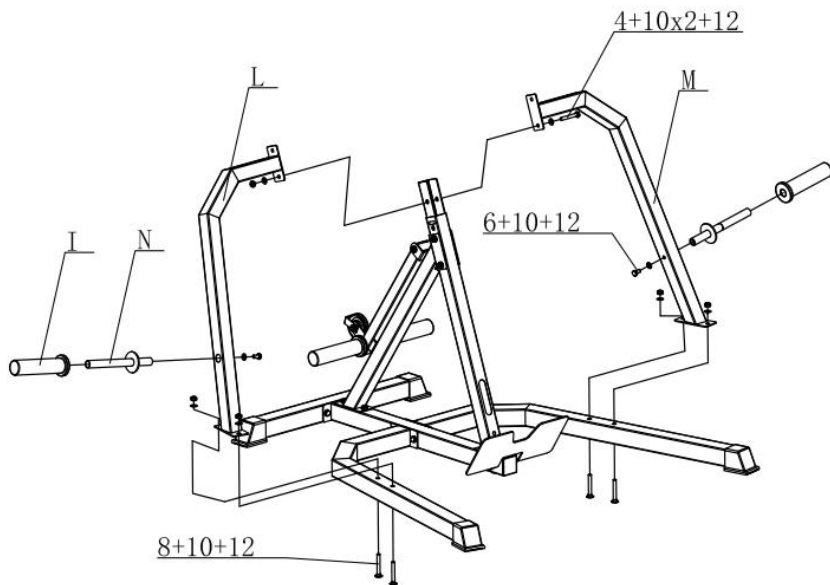



# STEP3:

<p>I</p>  <p>2PCS</p>	<p>L</p>  <p>1PCS</p>	<p>M</p>  <p>1PCS</p>	<p>N</p>  <p>2PCS</p>	<p>4. BOLT (M10×70)</p>  <p>1 PCS</p>
<p>6. BOLT (M10×20)</p>  <p>2 PCS</p>	<p>8. Carriage BOLT (M10×75)</p>  <p>4 PCS</p>	<p>10. Washer (M10)</p>  <p>8 PCS</p>	<p>12. Locknut (M10)</p>  <p>5 PCS</p>	







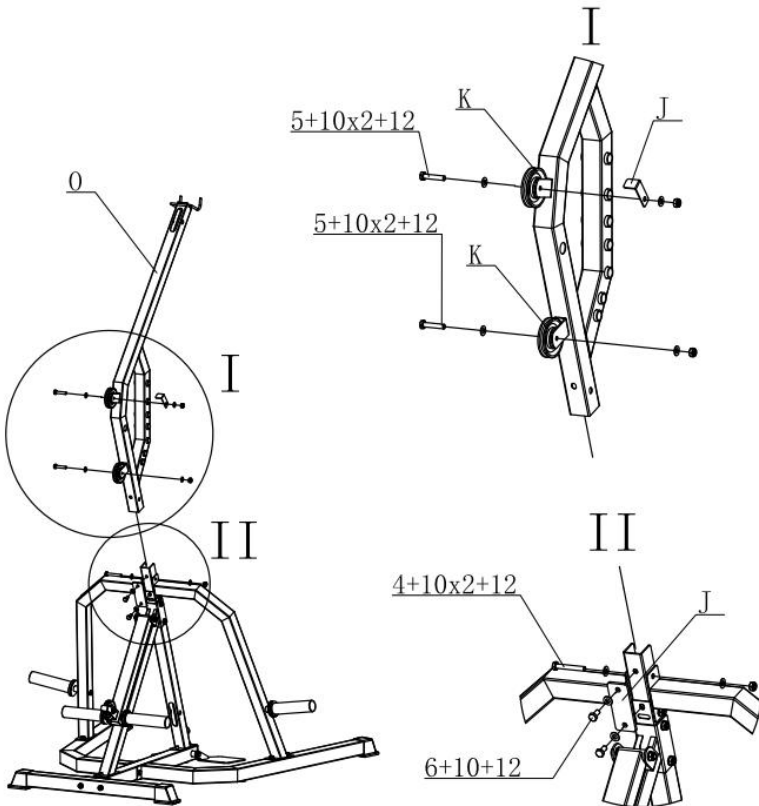









# STEP4:

<p>K</p>  <p>2PCS</p>	<p>J</p>  <p>1PCS</p>	<p>O</p>  <p>1 PCS</p>	<p>P</p>  <p>1 PCS</p>	<p>4. BOLT (M10×70)</p>  <p>1 PCS</p>
<p>5. BOLT (M10×50)</p>  <p>2 PCS</p>	<p>6. BOLT (M10×20)</p>  <p>2 PCS</p>	<p>10. Washer (M10)</p>  <p>8 PCS</p>	<p>12. Locknut (M10)</p>  <p>3 PCS</p>	









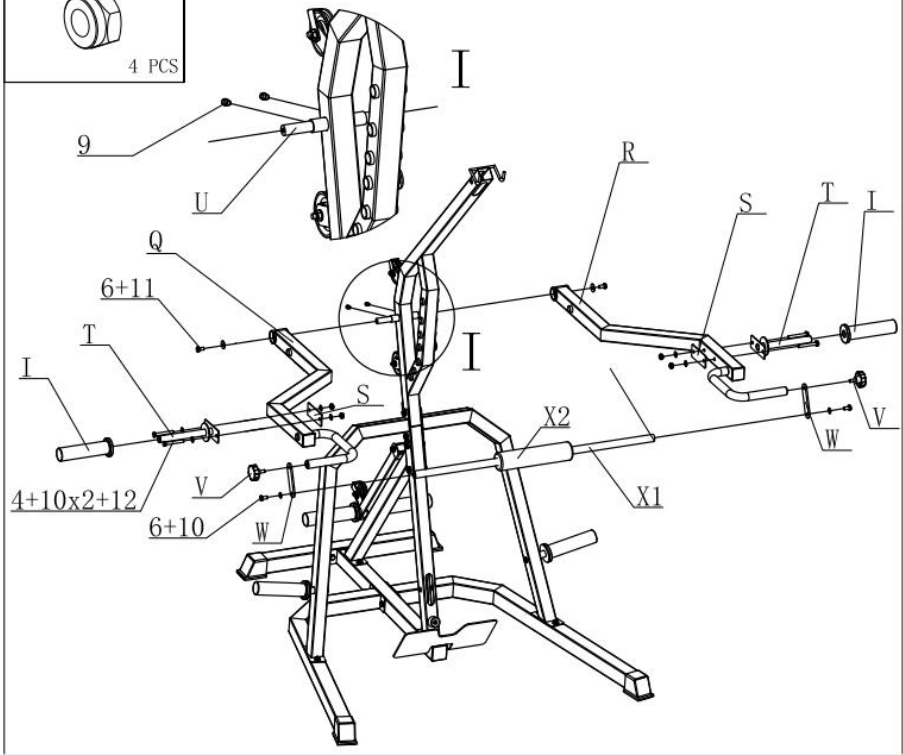



# STEP5:

<p>I</p>  <p>2PCS</p>	<p>Q</p>  <p>1PCS</p>	<p>R</p>  <p>1 PCS</p>	<p>S</p>  <p>2 PCS</p>	<p>T</p>  <p>2 PCS</p>
<p>U</p>  <p>1PCS</p>	<p>V</p>  <p>2PCS</p>	<p>W</p>  <p>2 PCS</p>	<p>X1</p>  <p>1 PCS</p>	<p>X2</p>  <p>1 PCS</p>
<p>4. BOLT (M10×70)</p>  <p>4 PCS</p>	<p>6. BOLT (M10×20)</p>  <p>4 PCS</p>	<p>9. BOLT (M8×16)</p>  <p>2 PCS</p>	<p>10. Washer (M10)</p>  <p>10 PCS</p>	<p>11. Big Washer (M10)</p>  <p>2 PCS</p>

12. Locknut (M10)



# STEP6:

<p>K</p>  <p>2PCS</p>	<p>Y1</p>  <p>1 PCS</p>	<p>Y2</p>  <p>1 PCS</p>	<p>Y3</p>  <p>3 PCS</p>	<p>Y4</p>  <p>2 PCS</p>
<p>Z</p>  <p>1 PCS</p>	<p>4. BOLT (M10×70)</p>  <p>2 PCS</p>	<p>7. Spacer Sleeve (10)</p>  <p>4 PCS</p>	<p>10. Washer (M10)</p>  <p>4 PCS</p>	<p>12. Locknut (M10)</p>  <p>2 PCS</p>

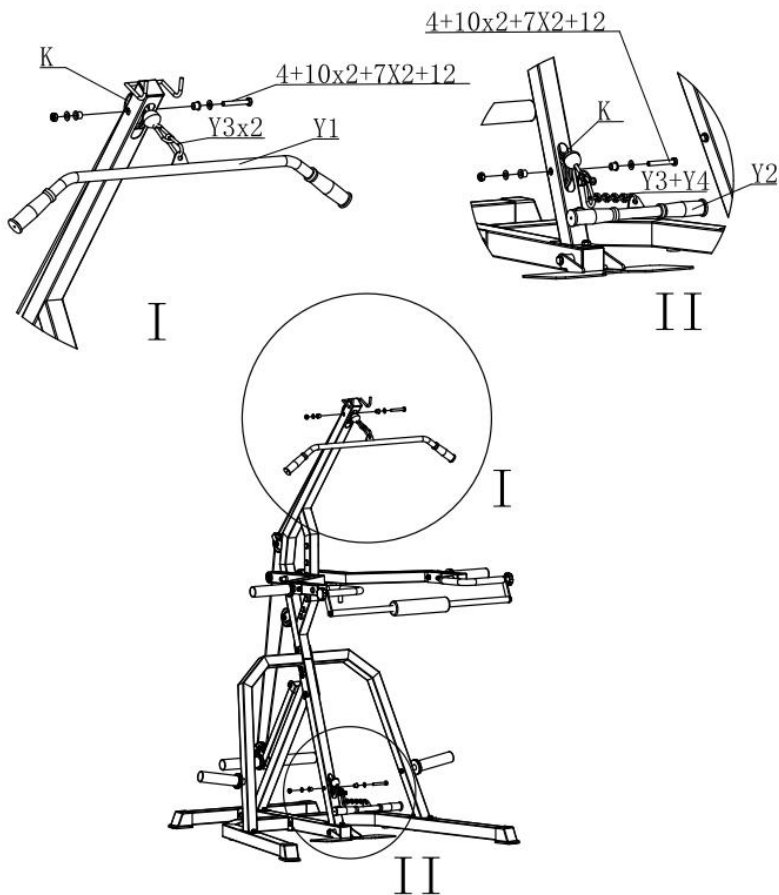

## MAINTENANCE AND CONDITIONING GUIDELINES

1.Cleaning and maintenance: Wipe down the squat with a clean, soft, damp cloth. Do not expose the plastic part to corrosive solvents. Wipe off any sweat stains that may be left on the squat after each use.

Be careful not to let too much moisture come into contact with the electronic watch screen, as this may cause the circuit to malfunction. Please avoid direct sunlight on squats, especially electronic watch screens, to avoid damage to the product. Check weekly for loose screws, nuts and pedals.

2.Storage: Keep the squat machine in a dry and clean environment away from children and pets.

**3.Note: Do not use for more than 15 minutes at a time.**

## SAFE USE NEEDS TO KNOW

Thank you for purchasing our products. The correct use of this device is the guarantee of your safety and health. It is very important to read the manual carefully before using this device! Only when this equipment is properly installed, maintained and used can exercise be safe and effective.

1, This equipment is only suitable for indoor use, home use. The maximum user weight and load is 120KG.

2. This device belongs to the HC grade and is not suitable for medical use.

3, Before assembly, it is necessary to fully understand the list of parts provided for this equipment, and install in full accordance with the instruction manual.

4, Installation needs to use the appropriate tools to install. If necessary, please ask the second person to assist you to in stalling together.

5, The fitness equipment needs to be placed on a flat, non-slip ground to use, If placed in a wet space, the long-term use of the equipment will be

affected by corrosion.

6, Please check whether the screw parts are locked before use, and ensure that there is a space distance of 0.6 meters around the equipment, and there is no prominent adjustable device.

7, Regularly check whether the various connection parts of the equipment are tight and whether the state is normal, in order to ensure the safety level of the equipment.

8. Do not use corrosive cleaning agents during maintenance and cleaning to avoid liquid entering the equipment through the tail or gap.

9. This device is used by adults, children and pets should stay away from this device, and can only be operated under the guidance of adults.

10, This equipment can only be used by one person at the same time, Please point out the possible dangers to the people around you, such as the danger of moving parts during exercise.

11. Wear well-fitting clothing when exercising to prevent loose clothing from tripping on equipment or restricting movement.

12. Please don't exercise before and after meals.

13. Please pay attention to the exercise methods in the instructions.

14, Please consult your family doctor before exercise, he will tell you what kind of exercise and exercise load is suitable for you, The wrong exercise can damage your health, excessive training can lead to serious injury or death, If you feel dizzy, please stop training immediately.

15, please keep this manual and installation tools.

16, If you have any questions or need our assistance, please contact our after-sales service department.

## **Important advice**

1. Follow the installation instructions and use only the parts configured with this device.

2, In principle, we do not regard sports equipment as toys, and it can only be used by people who know the relevant knowledge or have been guided.

3. If you experience dizziness, nausea, chest pain, or other abnormal symptoms, stop exercising immediately and consult your doctor.
4. Such as children and disabled people, only under the guidance of a skilled operator should use this equipment.
5. Please note that you and others must not put any part of the body into the sports area.
6. In the parts of the equipment that can be adjusted, pay special attention to the maximum limit position marked.
7. Only regular inspection for wear and loose parts, in order to ensure that the equipment is in a high-quality state.

## **Assembly instruction**

1. The product must be carefully installed by adults, in case of uncertainty, please ask for technical experience to help.
2. Unpack all the packaging materials, place the various parts, make it more clearer and easier to understand the assembly, use the pad to protect the installation surface, and avoid dirt or scratch.
3. And then according to the parts list, to check whether the parts are complete, only after the installation can packaging materials be discarded.
4. Before starting the assembly, please carefully read the installation instructions and understand the corresponding schematic diagram.
5. Please note that when using tools and manual operation, there may be a risk of operating injury, so be careful when installing the product.
6. After assembling the product according to the instructions, please carefully check whether the screws, nuts and knobs are installed correctly and tightened in place.
7. After installation, please do not put the tool randomly.
8. It is recommended that you find a protective pad (not provided in the product), placed under the product to protect the floor, because the product rubber inevitably leaves traces.

## **Motion specification**

1. Did you know that moderate endurance exercise (such as about 30 minutes, 2 times a week) can greatly improve your health? Your blood pressure, cholesterol, blood sugar, initiative, and even your mood can all be greatly improved by a small amount of exercise. You can reduce your body fat percentage by making modest changes to your body shape and matching your nutrient intake accordingly.
- 2, Exercise should always start with a warm up. The harder the workout ahead, the more important it is to warm up. Warming up prepares the body for the load, stimulates the cardiovascular system and protects ligaments, tendons and joints from injury. It also helps reduce the risk of cramps and muscle injuries.

**Manufacturer:** Shanghaimuxinmuyeyouxiangongsi

**Address:** Shuangchenglu 803nong11hao1602A-1609shi, baoshanqu, shanghai 200000 CN.

**Imported to AUS:** SIHAO PTY LTD. 1 ROKEVA STREETEASTWOOD NSW 2122 Australia

**Imported to USA:** Sanven Technology Ltd. Suite 250, 9166 Anaheim Place, Rancho Cucamonga, CA 91730

<b>UK</b>	<b>REP</b>
-----------	------------

YH CONSULTING LIMITED. C/O YH Consulting Limited Office 147, Centurion House, London Road, Staines-upon-Thames, Surrey, TW18 4AX

<b>EC</b>	<b>REP</b>
-----------	------------

E-CrossStu GmbH  
Mainzer Landstr.69,  
60329 Frankfurt am Main.



# **VEVOR**

**Affordable. Reliable. Home Improvement.**

## **MACHINE À HACK SQUAT**

**MODÈLE : HM2901A**

# VEVOR

Affordable. Reliable. Home Improvement.

## HACK SQUAT MACHINE

MODÈLE : HM2901A

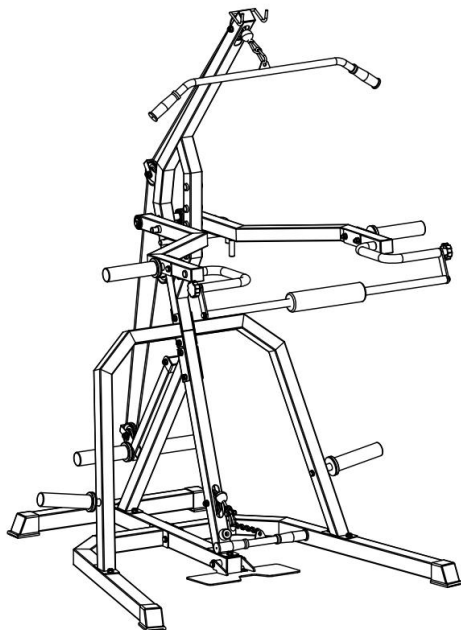

Installation Instruction



Ceci est le mode d'emploi d'origine. Veuillez lire attentivement l'intégralité du manuel avant utilisation. VEVOR se réserve le droit d'interpréter clairement ce manuel d'utilisation. L'apparence du produit dépend du produit que vous avez reçu. Veuillez nous excuser pour les éventuelles mises à jour technologiques ou logicielles.





























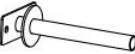

Avertissement - Pour réduire le risque de blessure, l'utilisateur doit lire attentivement le manuel d'instructions.

## LISTE DE CONTRÔLE AVANT L'ASSEMBLAGE









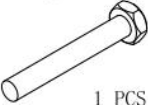
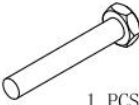

**Assurez-vous d'inclure toutes les pièces avant de commencer l'assemblage.**

Noté: Certains accessoires de vis ont été installés sur le produit et doivent être desserrés puis connectés.

# PARTS LIST









<p>A</p>  <p style="text-align: center;">1PCS</p>	<p>B</p>  <p style="text-align: center;">1PCS</p>	<p>C</p>  <p style="text-align: center;">1PCS</p>	<p>D</p>  <p style="text-align: center;">1PCS</p>	<p>E</p>  <p style="text-align: center;">1PCS</p>
<p>F</p>  <p style="text-align: center;">1PCS</p>	<p>G</p>  <p style="text-align: center;">1PCS</p>	<p>H</p>  <p style="text-align: center;">1PCS</p>	<p>I</p>  <p style="text-align: center;">6PCS</p>	<p>J</p>  <p style="text-align: center;">2PCS</p>
<p>K</p>  <p style="text-align: center;">5 PCS</p>	<p>L</p>  <p style="text-align: center;">1PCS</p>	<p>M</p>  <p style="text-align: center;">1PCS</p>	<p>N</p>  <p style="text-align: center;">2PCS</p>	<p>O</p>  <p style="text-align: center;">1 PCS</p>
<p>P</p>  <p style="text-align: center;">1 PCS</p>	<p>Q</p>  <p style="text-align: center;">1PCS</p>	<p>R</p>  <p style="text-align: center;">1 PCS</p>	<p>S</p>  <p style="text-align: center;">2 PCS</p>	<p>T</p>  <p style="text-align: center;">2 PCS</p>
<p>U</p>  <p style="text-align: center;">1PCS</p>	<p>V</p>  <p style="text-align: center;">2PCS</p>	<p>W</p>  <p style="text-align: center;">2 PCS</p>	<p>X1</p>  <p style="text-align: center;">1 PCS</p>	<p>X2</p>  <p style="text-align: center;">1 PCS</p>
<p>Y1</p>  <p style="text-align: center;">1 PCS</p>	<p>Y2</p>  <p style="text-align: center;">1 PCS</p>	<p>Y3</p>  <p style="text-align: center;">3 PCS</p>	<p>Y4</p>  <p style="text-align: center;">1 PCS</p>	<p>Z</p>  <p style="text-align: center;">1 PCS</p>

# HARDWARE LIST

<p>1. BOLT (M10×135)</p>  <p style="text-align: center;">1 PCS</p>	<p>2. BOLT (M10×100)</p>  <p style="text-align: center;">1 PCS</p>	<p>3. BOLT (M10×80)</p>  <p style="text-align: center;">4 PCS</p>	<p>4. BOLT (M10×70)</p>  <p style="text-align: center;">10 PCS</p>	<p>5. BOLT (M10×50)</p>  <p style="text-align: center;">3 PCS</p>
<p>6. BOLT (M10×20)</p>  <p style="text-align: center;">8 PCS</p>	<p>7. Spacer Sleeve (10)</p>  <p style="text-align: center;">4 PCS</p>	<p>8. Carriage BOLT (M10×75)</p>  <p style="text-align: center;">8 PCS</p>	<p>9. BOLT (M8×16)</p>  <p style="text-align: center;">2 PCS</p>	<p>10. Washer (M10)</p>  <p style="text-align: center;">52 PCS</p>
<p>11. Big Washer (M10)</p>  <p style="text-align: center;">2 PCS</p>	<p>12. Locknut (M10)</p>  <p style="text-align: center;">27 PCS</p>			







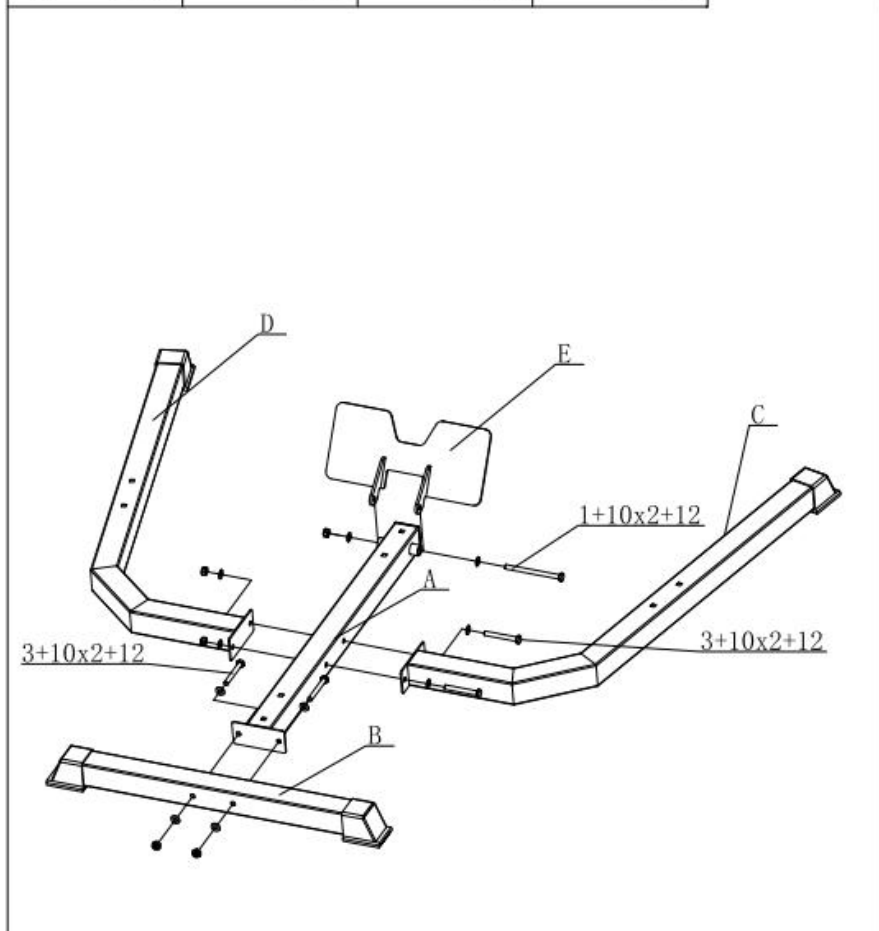

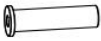

# INSTRUCTIONS DE MONTAGE

## STEP 1:

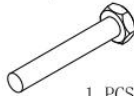
<p>A</p>  <p>1PCS</p>	<p>B</p>  <p>1PCS</p>	<p>C</p>  <p>1PCS</p>	<p>D</p>  <p>1PCS</p>	<p>E</p>  <p>4PCS</p>
<p>1. BOLT (M10 × 135)</p>  <p>1 PCS</p>	<p>3. BOLT (M10 × 80)</p>  <p>4 PCS</p>	<p>10. Washer (M10)</p>  <p>10 PCS</p>	<p>12. Locknut (M10)</p>  <p>5 PCS</p>	







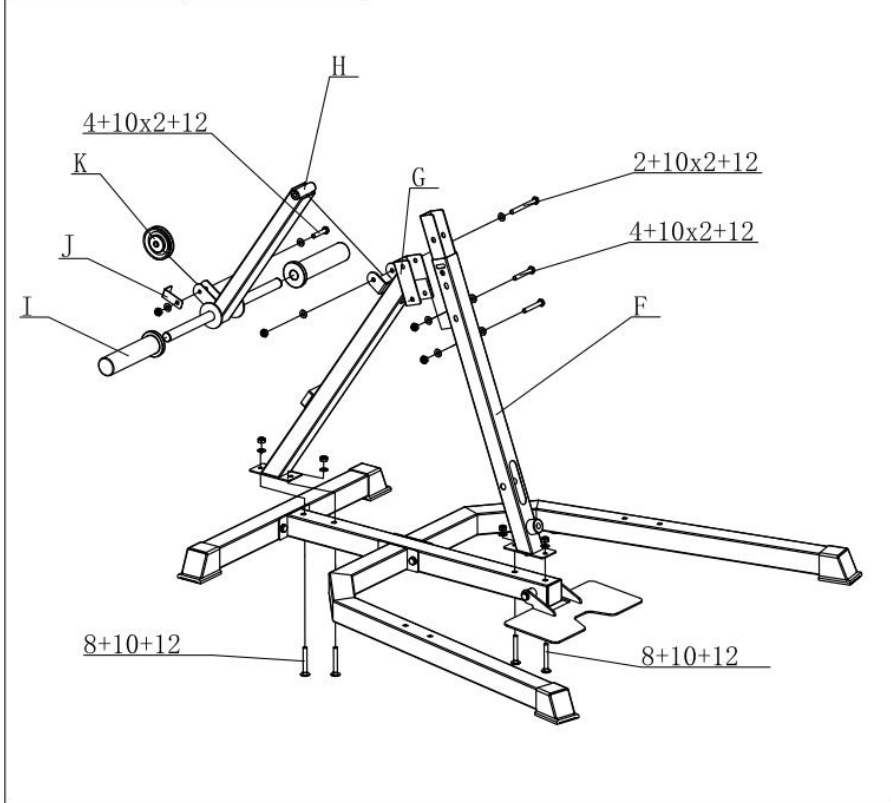



# STEP2:

<p>F</p>  <p>1PCS</p>	<p>G</p>  <p>1PCS</p>	<p>H</p>  <p>1PCS</p>	<p>I</p>  <p>2PCS</p>	<p>J</p>  <p>1PCS</p>
<p>K</p>  <p>1 PCS</p>	<p>2. BOLT (M10×100)</p>  <p>1 PCS</p>	<p>4. BOLT (M10×70)</p>  <p>2 PCS</p>	<p>5. BOLT (M10×50)</p>  <p>1 PCS</p>	<p>8. Carriage BOLT (M10×75)</p>  <p>4 PCS</p>
<p>10. Washer (M10)</p>  <p>12 PCS</p>	<p>12. Locknut (M10)</p>  <p>8 PCS</p>			







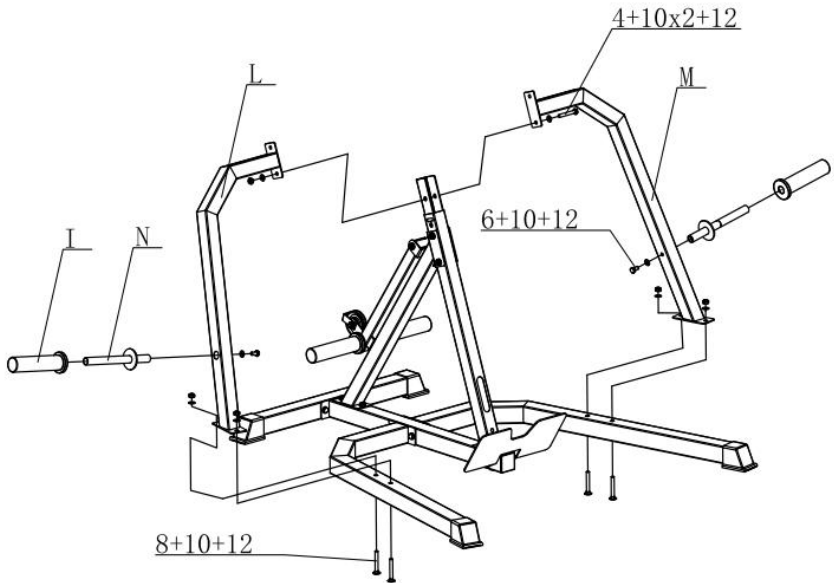



# STEP3:

<p>I</p>  <p>2PCS</p>	<p>L</p>  <p>1PCS</p>	<p>M</p>  <p>1PCS</p>	<p>N</p>  <p>2PCS</p>	<p>4. BOLT (M10×70)</p>  <p>1 PCS</p>
<p>6. BOLT (M10×20)</p>  <p>2 PCS</p>	<p>8. Carriage BOLT (M10×75)</p>  <p>4 PCS</p>	<p>10. Washer (M10)</p>  <p>8 PCS</p>	<p>12. Locknut (M10)</p>  <p>5 PCS</p>	







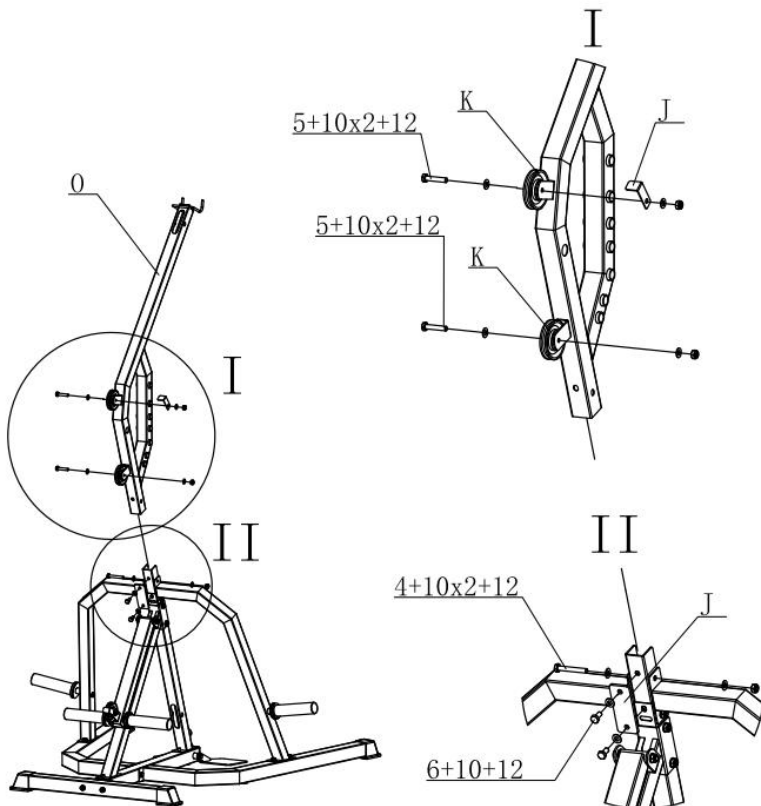









# STEP4:

<p>K</p>  <p>2PCS</p>	<p>J</p>  <p>1PCS</p>	<p>O</p>  <p>1 PCS</p>	<p>P</p>  <p>1 PCS</p>	<p>4. BOLT (M10×70)</p>  <p>1 PCS</p>
<p>5. BOLT (M10×50)</p>  <p>2 PCS</p>	<p>6. BOLT (M10×20)</p>  <p>2 PCS</p>	<p>10. Washer (M10)</p>  <p>8 PCS</p>	<p>12. Locknut (M10)</p>  <p>3 PCS</p>	







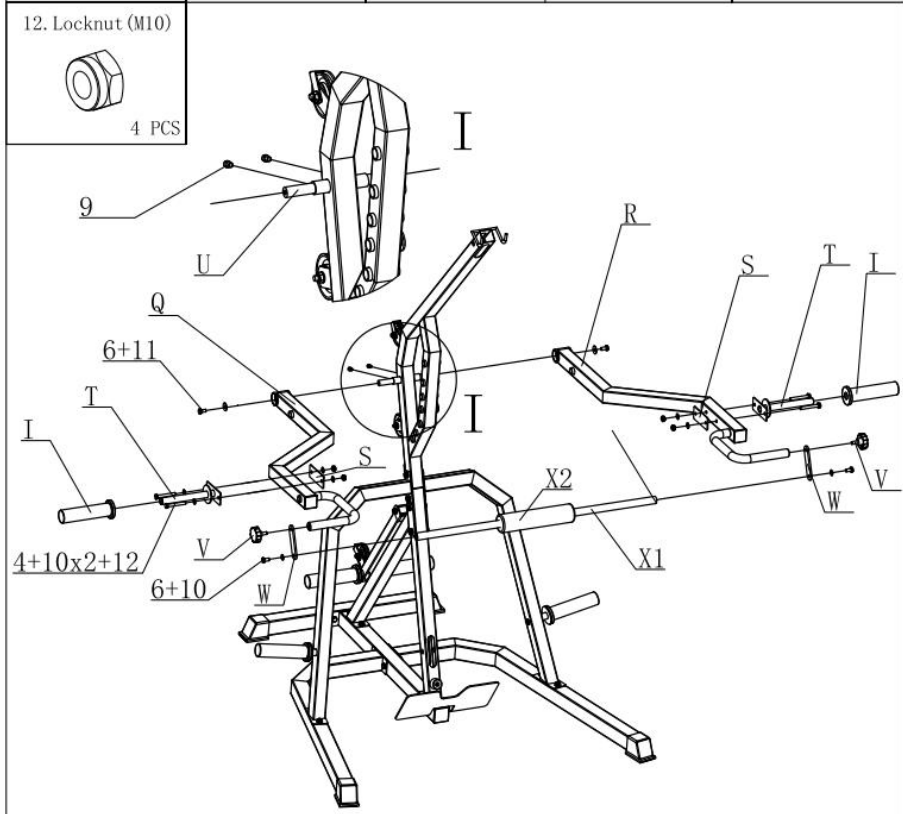





# STEP5:

<p>I</p>  <p>2PCS</p>	<p>Q</p>  <p>1PCS</p>	<p>R</p>  <p>1 PCS</p>	<p>S</p>  <p>2 PCS</p>	<p>T</p>  <p>2 PCS</p>
<p>U</p>  <p>1PCS</p>	<p>V</p>  <p>2PCS</p>	<p>W</p>  <p>2 PCS</p>	<p>X1</p>  <p>1 PCS</p>	<p>X2</p>  <p>1 PCS</p>
<p>4. BOLT (M10×70)</p>  <p>4 PCS</p>	<p>6. BOLT (M10×20)</p>  <p>4 PCS</p>	<p>9. BOLT (M8×16)</p>  <p>2 PCS</p>	<p>10. Washer (M10)</p>  <p>10 PCS</p>	<p>11. Big Washer (M10)</p>  <p>2 PCS</p>



# STEP6:

<p>K</p>  <p>2PCS</p>	<p>Y1</p>  <p>1 PCS</p>	<p>Y2</p>  <p>1 PCS</p>	<p>Y3</p>  <p>3 PCS</p>	<p>Y4</p>  <p>2 PCS</p>
<p>Z</p>  <p>1 PCS</p>	<p>4. BOLT (M10×70)</p>  <p>2 PCS</p>	<p>7. Spacer Sleeve (10)</p>  <p>4 PCS</p>	<p>10. Washer (M10)</p>  <p>4 PCS</p>	<p>12. Locknut (M10)</p>  <p>2 PCS</p>

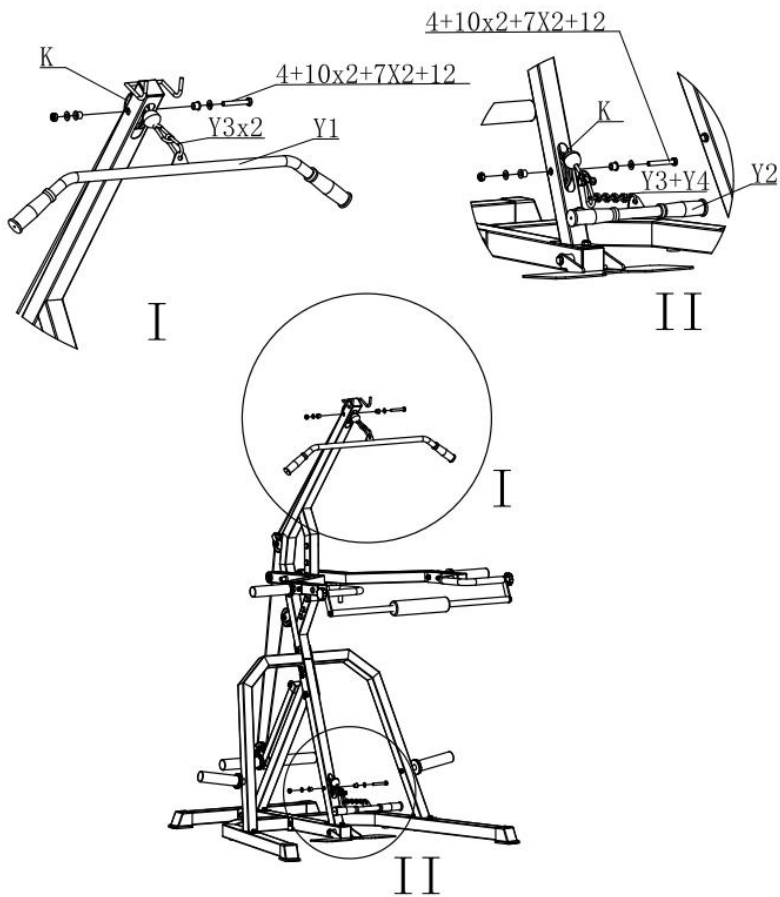

## DIRECTIVES D'ENTRETIEN ET DE CONDITIONNEMENT

1. Nettoyage et entretien : Essuyez le squat avec un chiffon propre, doux et humide. N'exposez pas la partie plastique à des solvants corrosifs. Essuyez les éventuelles traces de transpiration après chaque utilisation. Veillez à ce que l'écran de la montre électronique ne soit pas trop humide, car cela pourrait entraîner un dysfonctionnement du circuit. Évitez d'exposer les squats, en particulier les écrans de montres électroniques, à la lumière directe du soleil, afin de ne pas les endommager. Vérifiez chaque semaine que les vis, les écrous et les pédales ne sont pas desserrés.
  2. Stockage : Gardez la machine à squat dans un environnement sec et propre, loin des enfants et des animaux domestiques.
- 3.Remarque : ne pas utiliser pendant plus de 15 minutes à la fois .**

## UNE UTILISATION SÛRE NÉCESSITE DE SAVOIR

Merci d'avoir acheté nos produits. Une utilisation correcte de cet appareil est la garantie de votre sécurité et de votre santé. Il est essentiel de lire attentivement le manuel avant d'utiliser cet appareil ! Seul un équipement correctement installé, entretenu et utilisé garantit un entraînement sûr et efficace.

1. Cet équipement est uniquement destiné à un usage intérieur et domestique. La limite maximale le poids et la charge de l'utilisateur sont de 120 kg.
2. Cet appareil appartient à la catégorie HC et ne convient pas à un usage médical.
- 3, Avant l'assemblage, il est nécessaire de bien comprendre la liste des pièces fourni pour cet équipement et installer en totale conformité avec le manuel d'instructions.
- 4, L'installation nécessite l' utilisation des outils appropriés . Si nécessaire,

- veuillez demander à la deuxième personne de vous aider. caler ensemble .
- 5, L'équipement de fitness doit être placé sur un sol plat et antidérapant pour être utilisé. S'il est placé dans un espace humide, l'utilisation à long terme de l'équipement sera affectée par la corrosion.
  - 6, Veuillez vérifier si les pièces à vis sont verrouillées avant utilisation et assurez-vous qu'il y a une distance d'espace de 0,6 mètre autour de l'équipement et qu'il n'y a pas de dispositif réglable proéminent.
  - 7, Vérifiez régulièrement si les différentes pièces de connexion de l'équipement sont bien serrées et si l'état est normal, afin de garantir le niveau de sécurité de l'équipement.
  8. N'utilisez pas d'agents de nettoyage corrosifs pendant l'entretien et le nettoyage pour éviter que du liquide ne pénètre dans l'équipement par la queue ou l'espace.
  9. Cet appareil est utilisé par des adultes, les enfants et les animaux domestiques doivent rester à l'écart de cet appareil et ne peut être utilisé que sous la direction d'adultes.
  10. Cet équipement ne peut être utilisé que par une seule personne à la fois. Veuillez signaler les dangers possibles pour les personnes qui vous entourent, tels que le danger des pièces mobiles pendant l'exercice.
  11. Portez des vêtements bien ajustés lorsque vous faites de l'exercice pour éviter que des vêtements amples ne trébuchent sur l'équipement ou ne restreignent les mouvements.
  12. Veuillez ne pas faire d'exercice avant et après les repas.
  13. Veuillez prêter attention aux méthodes d'exercice dans les instructions.
  - 14, Veuillez consulter votre médecin de famille avant de faire de l'exercice, il vous dira quel type d'exercice et quelle charge d'exercice vous conviennent. Un mauvais exercice peut nuire à votre santé, un entraînement excessif peut entraîner des blessures graves ou la mort. Si vous vous sentez étourdi , veuillez arrêter immédiatement l'entraînement.
  - 1 5 , veuillez conserver ce manuel et les outils d'installation.
  - 1 6 , Si vous avez des questions ou avez besoin de notre assistance,

veuillez contacter notre service après-vente.

## **Conseils importants**

1. Suivez les instructions d'installation et utilisez uniquement les pièces configurées avec cet appareil.
- 2, En principe, nous ne considérons pas les équipements sportifs comme des jouets et ils ne peuvent être utilisés que par des personnes qui possèdent les connaissances pertinentes ou qui ont été guidées.
3. Si vous ressentez des étourdissements, des nausées, des douleurs thoraciques ou d'autres symptômes anormaux, arrêtez immédiatement l'exercice et consultez votre médecin.
4. Les enfants et les personnes handicapées ne doivent utiliser cet équipement que sous la direction d'un opérateur qualifié.
5. Veuillez noter que vous et les autres ne devez mettre aucune partie du corps dans la zone sportive.
- 6, Dans les parties de l'équipement qui peuvent être réglées, faites particulièrement attention à la position limite maximale marquée.
- 7, Seule une inspection régulière des pièces d'usure et desserrées est nécessaire afin de garantir que l'équipement est dans un état de haute qualité .

## **Instructions de montage**

- 1, Le produit doit être installé avec soin par des adultes, en cas d'incertitude , s'il vous plaît demander une expérience technique pour vous aider.
- 2, Déballez tous les matériaux d'emballage, placez les différentes pièces, rendez l' assemblage plus clair et plus facile à comprendre, utilisez le tampon pour protéger la surface d'installation et évitez la saleté ou les rayures.
- 3, Et puis selon la liste des pièces , pour vérifier si les pièces sont complètes, ce n'est qu'après l'installation que les matériaux d'emballage

peuvent être utilisés être jeté.

4, Avant de commencer l'assemblage, veuillez lire attentivement les instructions d'installation et comprendre le schéma correspondant.

5. Veuillez noter que lors de l'utilisation d'outils et d'une opération manuelle, il peut y avoir un risque de blessure lors de l'utilisation, soyez donc prudent lors de l'installation du produit.

6. Après avoir assemblé le produit conformément aux instructions, veuillez vérifier soigneusement si les vis, les écrous et les boutons sont correctement installés et serrés en place.

7, Après l'installation, veuillez ne pas placer l'outil au hasard.

8, Il est recommandé de trouver un tampon de protection (non fourni dans le produit), placé sous le produit pour protéger le sol, car le caoutchouc du produit laisse inévitablement des traces.

## **Spécification du mouvement**

1. Saviez-vous qu'un exercice d'endurance modéré (environ 30 minutes, deux fois par semaine) peut grandement améliorer votre santé ? Votre tension artérielle, votre cholestérol, votre glycémie, votre esprit d'initiative et même votre humeur peuvent tous être grandement améliorés par une petite quantité d'exercice. Vous pouvez réduire votre pourcentage de masse grasse en modifiant légèrement votre silhouette et en adaptant vos apports nutritionnels en conséquence.

2. L' exercice doit toujours commencer par un échauffement. Plus l'entraînement est intense, plus il est important de s'échauffer. L'échauffement prépare le corps à la charge, stimule le système cardiovasculaire et protège les ligaments.

Il protège les tendons et les articulations des blessures. Il contribue également à réduire les risques de crampes et de blessures musculaires .



**Fabricant** : Shanghaimuxinmuyeyouxiangongsi

**Adresse** : Shuangchenglu 803nong11hao1602A-1609shi, baoshanqu,  
Shanghai 200 000 CN.

**Importé en Australie** : SIHAO PTY LTD. 1 ROKEVA STREET, ASTWOOD  
NSW 2122 Australie

**Importé aux États-Unis** : Sanven Technology Ltd. Suite 250, 9166  
Anaheim

Lieu, Rancho Cucamonga, CA 91730

<b>UK</b>	<b>REP</b>
-----------	------------

YH CONSULTING LIMITED. C/O YH Consulting  
Limited Office 147, Centurion House, London  
Road, Staines-upon-Thames, Surrey, TW18 4AX

<b>EC</b>	<b>REP</b>
-----------	------------

E-CrossStu GmbH  
Mainzer Landstr.69,  
60329 Frankfurt am Main.



# VEVOR

**Affordable. Reliable. Home Improvement.**

## **Hack-Squat-Maschine**

**MODELL: HM2901A**

# VEVOR

Affordable. Reliable. Home Improvement.

## HACK SQUAT MACHINE

MODELL: HM2901A

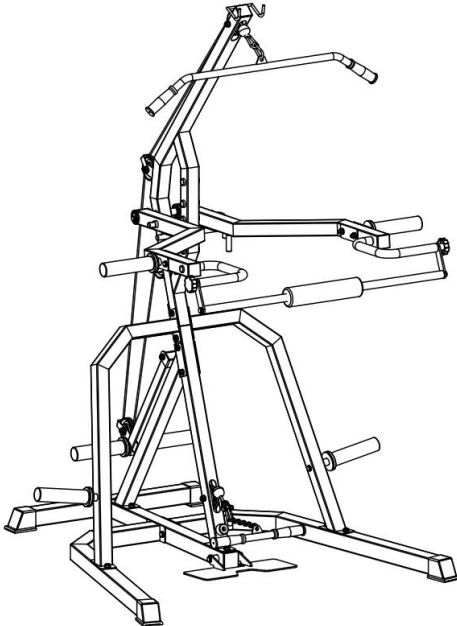

Installation Instruction



Dies ist die Originalanleitung. Bitte lesen Sie alle Anweisungen sorgfältig durch, bevor Sie das Gerät in Betrieb nehmen. VEVOR behält sich eine klare Auslegung unserer Bedienungsanleitung vor. Das Aussehen des Produkts hängt vom gelieferten Produkt ab. Bitte haben Sie Verständnis dafür, dass wir Sie nicht erneut über Technologie- oder Software-Updates informieren.

































Warnung: Um das Verletzungsrisiko zu verringern, muss der Benutzer die Bedienungsanleitung sorgfältig lesen.

## CHECKLISTE VOR DER MONTAGE









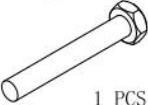
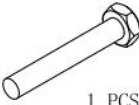

**Stellen Sie sicher, dass alle Teile enthalten sind, bevor Sie mit der Montage beginnen.**

Hinweis: Am Produkt sind einige Schraubzubehöerteile verbaut, die gelöst und anschließend angeschlossen werden müssen.

# PARTS LIST









<p>A</p>  <p style="text-align: center;">1PCS</p>	<p>B</p>  <p style="text-align: center;">1PCS</p>	<p>C</p>  <p style="text-align: center;">1PCS</p>	<p>D</p>  <p style="text-align: center;">1PCS</p>	<p>E</p>  <p style="text-align: center;">1PCS</p>
<p>F</p>  <p style="text-align: center;">1PCS</p>	<p>G</p>  <p style="text-align: center;">1PCS</p>	<p>H</p>  <p style="text-align: center;">1PCS</p>	<p>I</p>  <p style="text-align: center;">6PCS</p>	<p>J</p>  <p style="text-align: center;">2PCS</p>
<p>K</p>  <p style="text-align: center;">5 PCS</p>	<p>L</p>  <p style="text-align: center;">1PCS</p>	<p>M</p>  <p style="text-align: center;">1PCS</p>	<p>N</p>  <p style="text-align: center;">2PCS</p>	<p>O</p>  <p style="text-align: center;">1 PCS</p>
<p>P</p>  <p style="text-align: center;">1 PCS</p>	<p>Q</p>  <p style="text-align: center;">1PCS</p>	<p>R</p>  <p style="text-align: center;">1 PCS</p>	<p>S</p>  <p style="text-align: center;">2 PCS</p>	<p>T</p>  <p style="text-align: center;">2 PCS</p>
<p>U</p>  <p style="text-align: center;">1PCS</p>	<p>V</p>  <p style="text-align: center;">2PCS</p>	<p>W</p>  <p style="text-align: center;">2 PCS</p>	<p>X1</p>  <p style="text-align: center;">1 PCS</p>	<p>X2</p>  <p style="text-align: center;">1 PCS</p>
<p>Y1</p>  <p style="text-align: center;">1 PCS</p>	<p>Y2</p>  <p style="text-align: center;">1 PCS</p>	<p>Y3</p>  <p style="text-align: center;">3 PCS</p>	<p>Y4</p>  <p style="text-align: center;">1 PCS</p>	<p>Z</p>  <p style="text-align: center;">1 PCS</p>

# HARDWARE LIST

<p>1. BOLT (M10×135)</p>  <p style="text-align: center;">1 PCS</p>	<p>2. BOLT (M10×100)</p>  <p style="text-align: center;">1 PCS</p>	<p>3. BOLT (M10×80)</p>  <p style="text-align: center;">4 PCS</p>	<p>4. BOLT (M10×70)</p>  <p style="text-align: center;">10 PCS</p>	<p>5. BOLT (M10×50)</p>  <p style="text-align: center;">3 PCS</p>
<p>6. BOLT (M10×20)</p>  <p style="text-align: center;">8 PCS</p>	<p>7. Spacer Sleeve (10)</p>  <p style="text-align: center;">4 PCS</p>	<p>8. Carriage BOLT (M10×75)</p>  <p style="text-align: center;">8 PCS</p>	<p>9. BOLT (M8×16)</p>  <p style="text-align: center;">2 PCS</p>	<p>10. Washer (M10)</p>  <p style="text-align: center;">52 PCS</p>
<p>11. Big Washer (M10)</p>  <p style="text-align: center;">2 PCS</p>	<p>12. Locknut (M10)</p>  <p style="text-align: center;">27 PCS</p>			







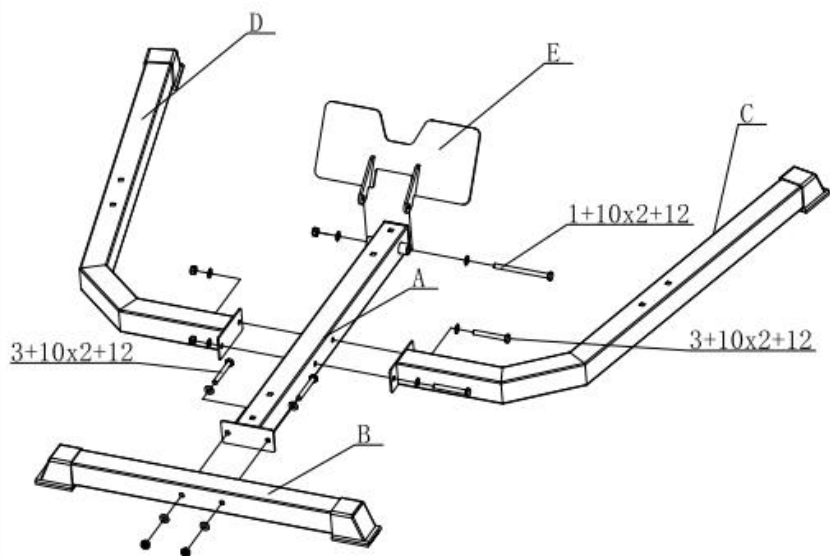

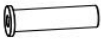

# MONTAGEANLEITUNG

## STEP 1:

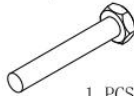
<p>A</p>  <p>1PCS</p>	<p>B</p>  <p>1PCS</p>	<p>C</p>  <p>1PCS</p>	<p>D</p>  <p>1PCS</p>	<p>E</p>  <p>4PCS</p>
<p>1. BOLT (M10 × 135)</p>  <p>1 PCS</p>	<p>3. BOLT (M10 × 80)</p>  <p>4 PCS</p>	<p>10. Washer (M10)</p>  <p>10 PCS</p>	<p>12. Locknut (M10)</p>  <p>5 PCS</p>	







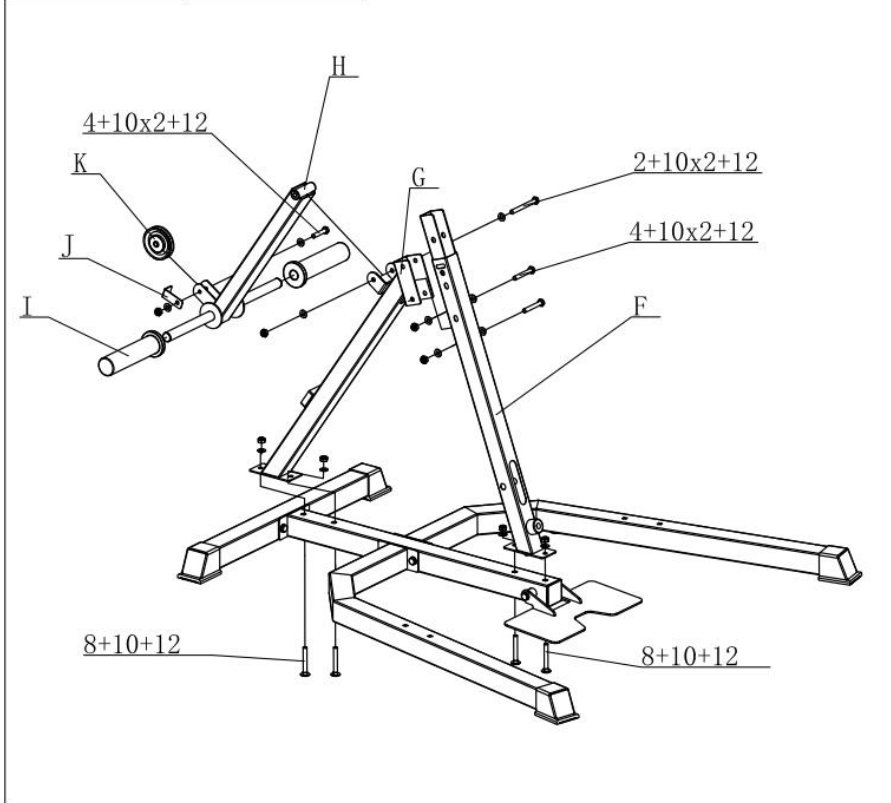



# STEP2:

<p>F</p>  <p>1PCS</p>	<p>G</p>  <p>1PCS</p>	<p>H</p>  <p>1PCS</p>	<p>I</p>  <p>2PCS</p>	<p>J</p>  <p>1PCS</p>
<p>K</p>  <p>1 PCS</p>	<p>2. BOLT (M10×100)</p>  <p>1 PCS</p>	<p>4. BOLT (M10×70)</p>  <p>2 PCS</p>	<p>5. BOLT (M10×50)</p>  <p>1 PCS</p>	<p>8. Carriage BOLT (M10×75)</p>  <p>4 PCS</p>
<p>10. Washer (M10)</p>  <p>12 PCS</p>	<p>12. Locknut (M10)</p>  <p>8 PCS</p>			







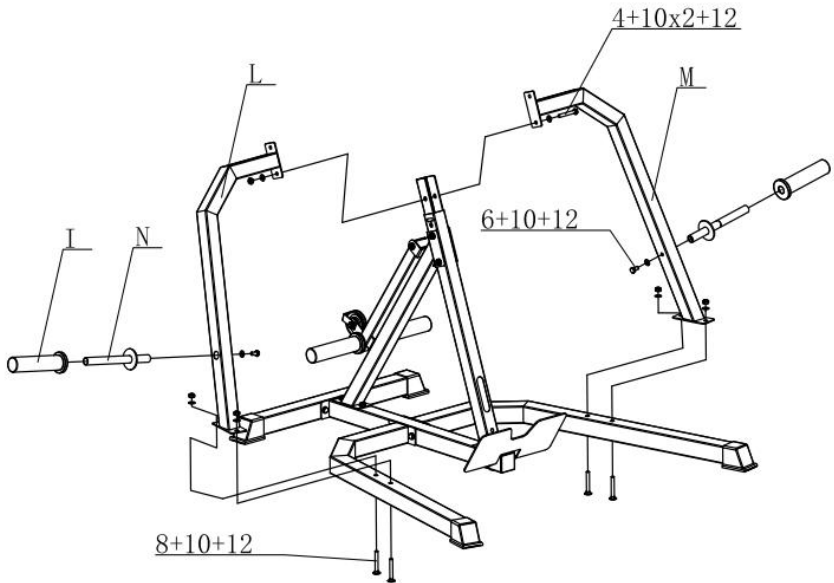



# STEP3:

<p>I</p>  <p>2PCS</p>	<p>L</p>  <p>1PCS</p>	<p>M</p>  <p>1PCS</p>	<p>N</p>  <p>2PCS</p>	<p>4. BOLT (M10×70)</p>  <p>1 PCS</p>
<p>6. BOLT (M10×20)</p>  <p>2 PCS</p>	<p>8. Carriage BOLT (M10×75)</p>  <p>4 PCS</p>	<p>10. Washer (M10)</p>  <p>8 PCS</p>	<p>12. Locknut (M10)</p>  <p>5 PCS</p>	







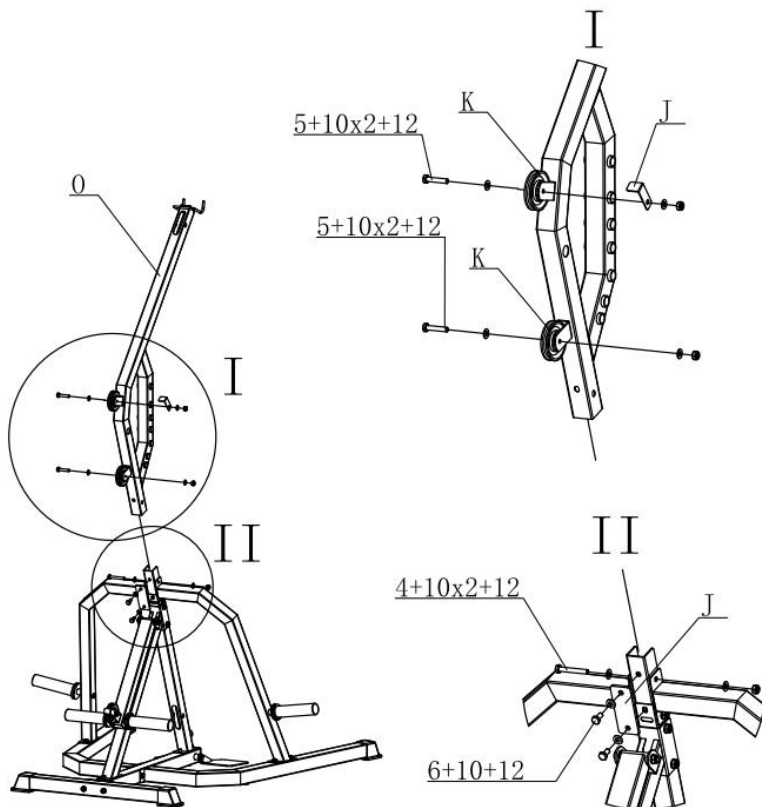







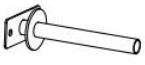

# STEP4:

<p>K</p>  <p>2PCS</p>	<p>J</p>  <p>1PCS</p>	<p>O</p>  <p>1 PCS</p>	<p>P</p>  <p>1 PCS</p>	<p>4. BOLT (M10×70)</p>  <p>1 PCS</p>
<p>5. BOLT (M10×50)</p>  <p>2 PCS</p>	<p>6. BOLT (M10×20)</p>  <p>2 PCS</p>	<p>10. Washer (M10)</p>  <p>8 PCS</p>	<p>12. Locknut (M10)</p>  <p>3 PCS</p>	







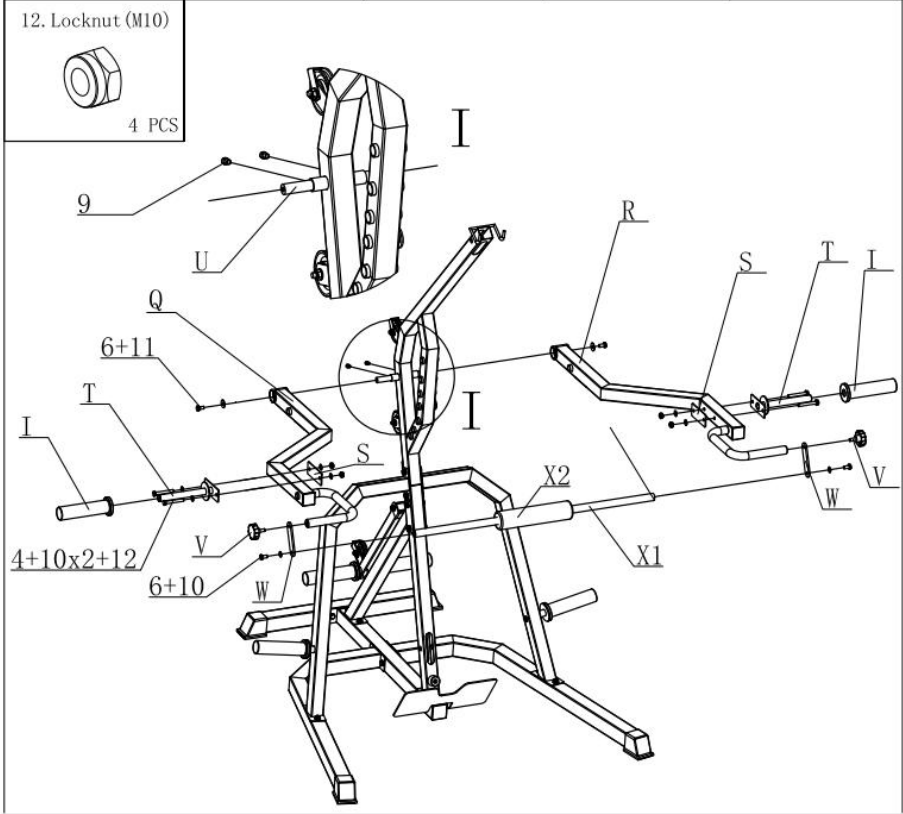





# STEP5:

<p>I</p>  <p>2PCS</p>	<p>Q</p>  <p>1PCS</p>	<p>R</p>  <p>1 PCS</p>	<p>S</p>  <p>2 PCS</p>	<p>T</p>  <p>2 PCS</p>
<p>U</p>  <p>1PCS</p>	<p>V</p>  <p>2PCS</p>	<p>W</p>  <p>2 PCS</p>	<p>X1</p>  <p>1 PCS</p>	<p>X2</p>  <p>1 PCS</p>
<p>4. BOLT (M10×70)</p>  <p>4 PCS</p>	<p>6. BOLT (M10×20)</p>  <p>4 PCS</p>	<p>9. BOLT (M8×16)</p>  <p>2 PCS</p>	<p>10. Washer (M10)</p>  <p>10 PCS</p>	<p>11. Big Washer (M10)</p>  <p>2 PCS</p>



# STEP6:

<p>K</p>  <p>2PCS</p>	<p>Y1</p>  <p>1 PCS</p>	<p>Y2</p>  <p>1 PCS</p>	<p>Y3</p>  <p>3 PCS</p>	<p>Y4</p>  <p>2 PCS</p>
<p>Z</p>  <p>1 PCS</p>	<p>4. BOLT (M10×70)</p>  <p>2 PCS</p>	<p>7. Spacer Sleeve (10)</p>  <p>4 PCS</p>	<p>10. Washer (M10)</p>  <p>4 PCS</p>	<p>12. Locknut (M10)</p>  <p>2 PCS</p>

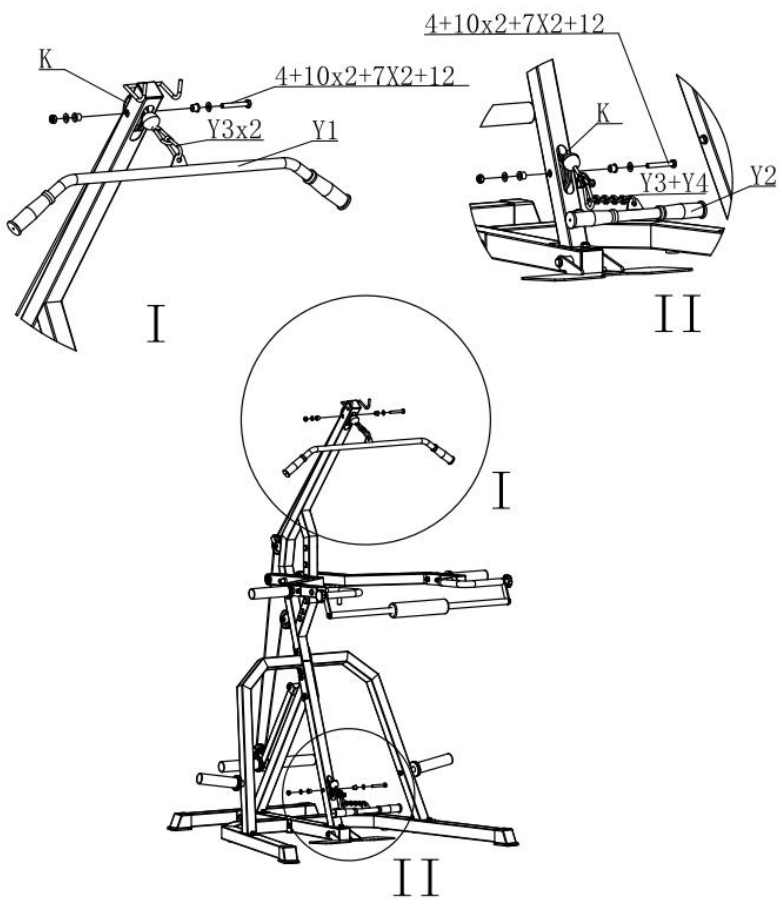

## WARTUNGS- UND KONDITIONIERUNGSRICHTLINIEN

1. Reinigung und Pflege: Wischen Sie die Kniebeuge mit einem sauberen, weichen, feuchten Tuch ab. Setzen Sie das Kunststoffteil keinen ätzenden Lösungsmitteln aus. Wischen Sie nach jedem Gebrauch eventuelle Schweißflecken auf der Kniebeuge ab.

Achten Sie darauf, dass nicht zu viel Feuchtigkeit auf das Display der elektronischen Uhr gelangt, da dies zu Fehlfunktionen der Schaltung führen kann. Vermeiden Sie direkte Sonneneinstrahlung auf Kniebeugen, insbesondere auf Displays elektronischer Uhren, um Schäden am Produkt zu vermeiden. Überprüfen Sie das Gerät wöchentlich auf lose Schrauben, Muttern und Pedale.

2. Lagerung: Bewahren Sie die Kniebeugenmaschine in einer trockenen und sauberen Umgebung außerhalb der Reichweite von Kindern und Haustieren auf.

**3. Hinweis: Nicht länger als 15 Minuten am Stück verwenden .**

## SICHERE VERWENDUNG MUSS WISSEN

Vielen Dank für den Kauf unserer Produkte. Die korrekte Verwendung dieses Geräts gewährleistet Ihre Sicherheit und Gesundheit. Lesen Sie die Bedienungsanleitung vor Gebrauch sorgfältig durch! Nur bei ordnungsgemäßer Installation, Wartung und Verwendung ist ein sicheres und effektives Training möglich.

1, Dieses Gerät ist nur für den Innenbereich und den Heimgebrauch geeignet. Die maximale Das maximale Benutzergewicht und die maximale Belastung betragen 120 kg.

2. Dieses Gerät gehört zur HC -Klasse und ist nicht für den medizinischen Gebrauch geeignet.

3. Vor der Montage ist es notwendig, die Liste der Teile vollständig zu verstehen für dieses Gerät vorgesehenen Anweisungen und installieren

Sie es in voller Übereinstimmung mit der Bedienungsanleitung.

4. Für die Installation müssen die entsprechenden Tools verwendet werden . Falls erforderlich, bitten Sie bitte die zweite Person, Ihnen bei der zusammenbleiben .

5. Das Fitnessgerät muss zur Verwendung auf einem ebenen, rutschfesten Untergrund aufgestellt werden. Wenn es in einem feuchten Raum aufgestellt wird, wird die langfristige Verwendung des Geräts durch Korrosion beeinträchtigt.

6. Bitte prüfen Sie vor der Verwendung, ob die Schraubteile verriegelt sind, und stellen Sie sicher, dass um das Gerät herum ein Abstand von 0,6 Metern eingehalten wird und keine hervorstehenden verstellbaren Geräte vorhanden sind.

7. Überprüfen Sie regelmäßig, ob die verschiedenen Verbindungsteile des Geräts fest sind und ob der Zustand normal ist, um das Sicherheitsniveau des Geräts zu gewährleisten.

8. Verwenden Sie bei der Wartung und Reinigung keine ätzenden Reinigungsmittel, um zu vermeiden, dass Flüssigkeit durch das Ende oder den Spalt in das Gerät eindringt.

9. Dieses Gerät wird von Erwachsenen verwendet. Kinder und Haustiere sollten sich von diesem Gerät fernhalten und es darf nur unter Anleitung von Erwachsenen bedient werden.

10. Dieses Gerät darf nur von einer Person gleichzeitig benutzt werden. Bitte weisen Sie die Personen in Ihrer Umgebung auf die möglichen Gefahren hin, beispielsweise auf die Gefahr durch bewegliche Teile während des Trainings.

11. Tragen Sie beim Training gut sitzende Kleidung, um zu verhindern, dass lose Kleidungsstücke über die Geräte stolpern oder die Bewegungsfreiheit einschränken.

12. Bitte treiben Sie vor und nach den Mahlzeiten keinen Sport.

13. Bitte beachten Sie die Übungsmethoden in der Anleitung.

14. Bitte konsultieren Sie Ihren Hausarzt, bevor Sie mit dem Training

beginnen. Er wird Ihnen sagen, welche Art von Training und Trainingsbelastung für Sie geeignet ist. Falsches Training kann Ihre Gesundheit schädigen. Übermäßiges Training kann zu schweren Verletzungen oder zum Tod führen. Wenn Ihnen schwindelig wird , beenden Sie das Training bitte sofort.

1 5 , bitte bewahren Sie dieses Handbuch und die Installationswerkzeuge auf.

1 6 , Wenn Sie Fragen haben oder unsere Hilfe benötigen, wenden Sie sich bitte an unseren Kundendienst.

## **Wichtiger Hinweis**

1. Befolgen Sie die Installationsanweisungen und verwenden Sie nur die mit diesem Gerät konfigurierten Teile.
2. Grundsätzlich betrachten wir Sportgeräte nicht als Spielzeug und dürfen nur von Personen benutzt werden, die über die entsprechenden Kenntnisse verfügen oder angeleitet wurden.
3. Wenn Sie Schwindel, Übelkeit, Brustschmerzen oder andere ungewöhnliche Symptome verspüren, beenden Sie das Training sofort und wenden Sie sich an Ihren Arzt.
4. Kinder und behinderte Menschen sollten dieses Gerät nur unter Anleitung eines erfahrenen Bedieners verwenden.
5. Bitte beachten Sie, dass Sie und andere Personen keine Körperteile in den Sportbereich bringen dürfen.  
verstellbaren Geräteteilen besonders auf die markierte maximale Endlage.
7. Nur regelmäßige Inspektion auf Verschleiß und lose Teile, um sicherzustellen, dass sich das Gerät in einem hochwertigen Zustand befindet .

## **Montageanleitung**

1. Das Produkt muss sorgfältig von Erwachsenen installiert werden, im Falle von Unsicherheiten , Bitte fragen Sie nach technischer Erfahrung, um

zu helfen.

2. Packen Sie alle Verpackungsmaterialien aus, platzieren Sie die verschiedenen Teile, um die Montage klarer und verständlicher zu gestalten. Verwenden Sie das Pad, um die Installationsoberfläche zu schützen und Schmutz oder Kratzer zu vermeiden.

3. Und dann gemäß der Stückliste , um zu überprüfen, ob die Teile vollständig sind, erst nach der Installation können Verpackungsmaterialien verworfen werden.

4. Lesen Sie vor Beginn der Montage die Installationsanweisungen sorgfältig durch und machen Sie sich mit dem entsprechenden schematischen Diagramm vertraut.

5. Bitte beachten Sie, dass bei der Verwendung von Werkzeugen und manueller Bedienung die Gefahr von Verletzungen besteht. Seien Sie daher bei der Installation des Produkts vorsichtig.

6. Nachdem Sie das Produkt gemäß der Anleitung zusammengebaut haben, prüfen Sie bitte sorgfältig, ob die Schrauben, Muttern und Knöpfe richtig angebracht und festgezogen sind.

7. Legen Sie das Werkzeug nach der Installation bitte nicht willkürlich ab.

8. Es wird empfohlen, eine Schutzunterlage (nicht im Lieferumfang enthalten) unter das Produkt zu legen, um den Boden zu schützen, da der Gummi des Produkts zwangsläufig Spuren hinterlässt.

## **Bewegungsspezifikation**

1. Wussten Sie, dass moderates Ausdauertraining (z. B. etwa 30 Minuten, zweimal pro Woche) Ihre Gesundheit deutlich verbessern kann? Blutdruck, Cholesterinspiegel, Blutzucker, Ihre Initiative und sogar Ihre Stimmung lassen sich durch ein wenig Bewegung deutlich verbessern. Sie können Ihren Körperfettanteil reduzieren, indem Sie Ihre Figur leicht verändern und Ihre Nährstoffaufnahme entsprechend anpassen.

2. Das Training sollte immer mit einem Aufwärmen beginnen . Je härter das bevorstehende Training, desto wichtiger ist das Aufwärmen. Das Aufwärmen bereitet den Körper auf die Belastung vor, regt das

Herz-Kreislauf-System an und schont die Bänder.

Sehnen und Gelenke vor Verletzungen. Es trägt auch dazu bei, das Risiko von Krämpfen und Muskelverletzungen zu verringern .

**Hersteller:** Shanghai muxinmuyeyouxiangongsi

**Adresse:** Shuangchenglu 803nong11hao1602A-1609shi, baoshanqu, Shanghai 200000 CN.

**Importiert nach AUS:** SIHAO PTY LTD. 1 ROKEVA STREET EASTWOOD NSW 2122 Australien

**Importiert in die USA:** Sanven Technology Ltd. Suite 250, 9166 Anaheim Place, Rancho Cucamonga, CA 91730

<b>UK</b>	<b>REP</b>
-----------	------------

YH CONSULTING LIMITED. C/O YH Consulting Limited Office 147, Centurion House, London Road, Staines-upon-Thames, Surrey, TW18 4AX

<b>EC</b>	<b>REP</b>
-----------	------------

E-CrossStu GmbH  
Mainzer Landstr.69,  
60329 Frankfurt am Main.



# **VEVOR**

**Affordable. Reliable. Home Improvement.**

## **MACCHINA PER HACK SQUAT**

**MODELLO: HM2901A**

# VEVOR

Affordable. Reliable. Home Improvement.

## HACK SQUAT MACHINE

MODELLO: HM2901A

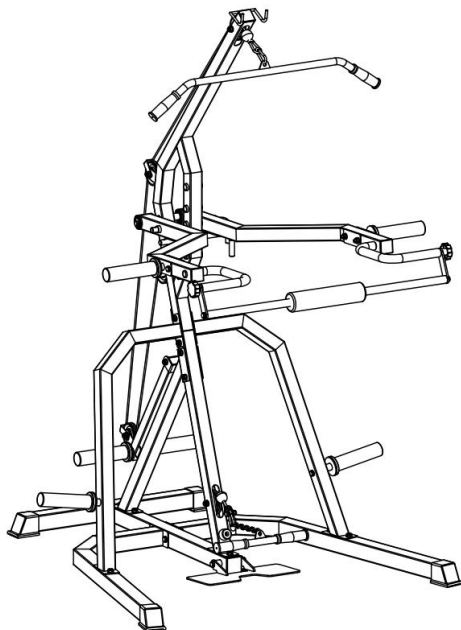

Installation Instruction



Queste sono le istruzioni originali, si prega di leggere attentamente tutte le istruzioni del manuale prima dell'uso. VEVOR si riserva la piena interpretazione del proprio manuale utente. L'aspetto del prodotto dipenderà dal prodotto ricevuto. Vi preghiamo di scusarci se non vi informeremo più in caso di aggiornamenti tecnologici o software sul nostro prodotto.

























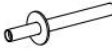



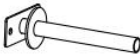

Avvertenza: per ridurre il rischio di lesioni, l'utente deve leggere attentamente il manuale di istruzioni.

## LISTA DI CONTROLLO PRE-ASSEMBLAGGIO









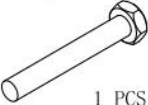
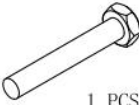

**Assicurarsi di includere tutti i pezzi prima di iniziare il montaggio.**

Notato: Sul prodotto sono stati installati alcuni accessori a vite che devono essere allentati e poi collegati.

# PARTS LIST









A  1PCS	B  1PCS	C  1PCS	D  1PCS	E  1PCS
F  1PCS	G  1PCS	H  1PCS	I  6PCS	J  2PCS
K  5 PCS	L  1PCS	M  1PCS	N  2PCS	O  1 PCS
P  1 PCS	Q  1PCS	R  1 PCS	S  2 PCS	T  2 PCS
U  1PCS	V  2PCS	W  2 PCS	X1  1 PCS	X2  1 PCS
Y1  1 PCS	Y2  1 PCS	Y3  3 PCS	Y4  1 PCS	Z  1 PCS

# HARDWARE LIST

<p>1. BOLT (M10×135)</p>  <p style="text-align: center;">1 PCS</p>	<p>2. BOLT (M10×100)</p>  <p style="text-align: center;">1 PCS</p>	<p>3. BOLT (M10×80)</p>  <p style="text-align: center;">4 PCS</p>	<p>4. BOLT (M10×70)</p>  <p style="text-align: center;">10 PCS</p>	<p>5. BOLT (M10×50)</p>  <p style="text-align: center;">3 PCS</p>
<p>6. BOLT (M10×20)</p>  <p style="text-align: center;">8 PCS</p>	<p>7. Spacer Sleeve (10)</p>  <p style="text-align: center;">4 PCS</p>	<p>8. Carriage BOLT (M10×75)</p>  <p style="text-align: center;">8 PCS</p>	<p>9. BOLT (M8×16)</p>  <p style="text-align: center;">2 PCS</p>	<p>10. Washer (M10)</p>  <p style="text-align: center;">52 PCS</p>
<p>11. Big Washer (M10)</p>  <p style="text-align: center;">2 PCS</p>	<p>12. Locknut (M10)</p>  <p style="text-align: center;">27 PCS</p>			







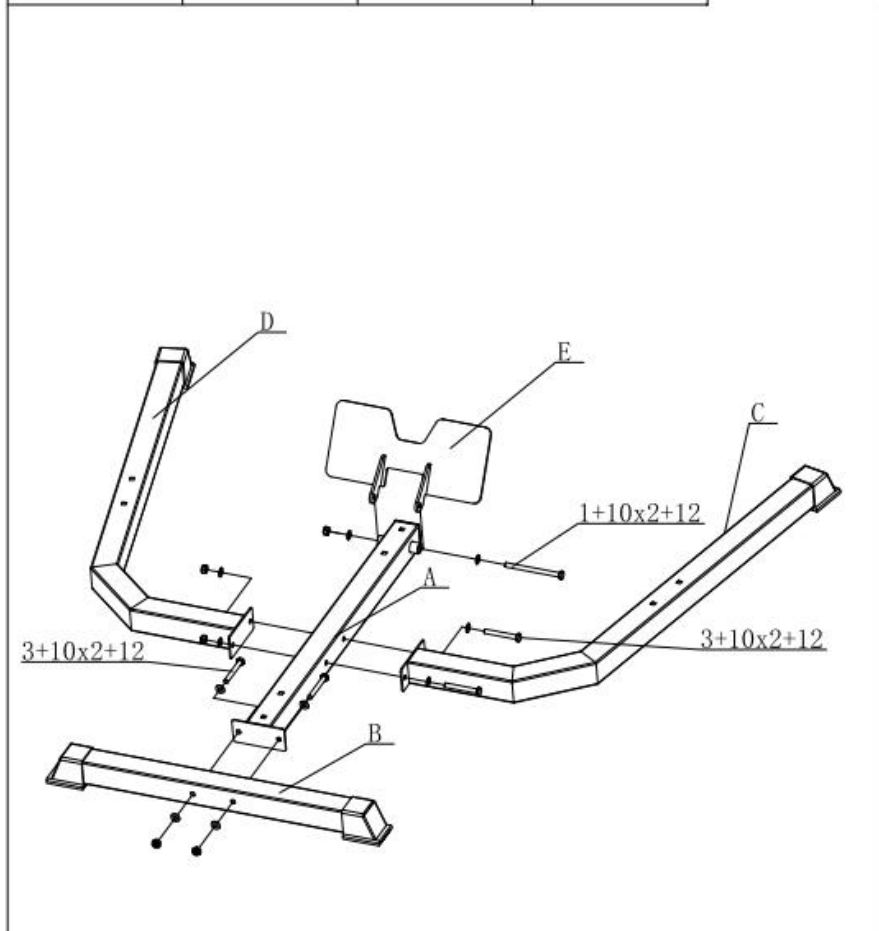

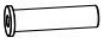

# ISTRUZIONI DI MONTAGGIO

## STEP 1:

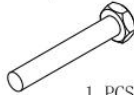
<p>A</p>  <p>1PCS</p>	<p>B</p>  <p>1PCS</p>	<p>C</p>  <p>1PCS</p>	<p>D</p>  <p>1PCS</p>	<p>E</p>  <p>4PCS</p>
<p>1. BOLT (M10 × 135)</p>  <p>1 PCS</p>	<p>3. BOLT (M10 × 80)</p>  <p>4 PCS</p>	<p>10. Washer (M10)</p>  <p>10 PCS</p>	<p>12. Locknut (M10)</p>  <p>5 PCS</p>	







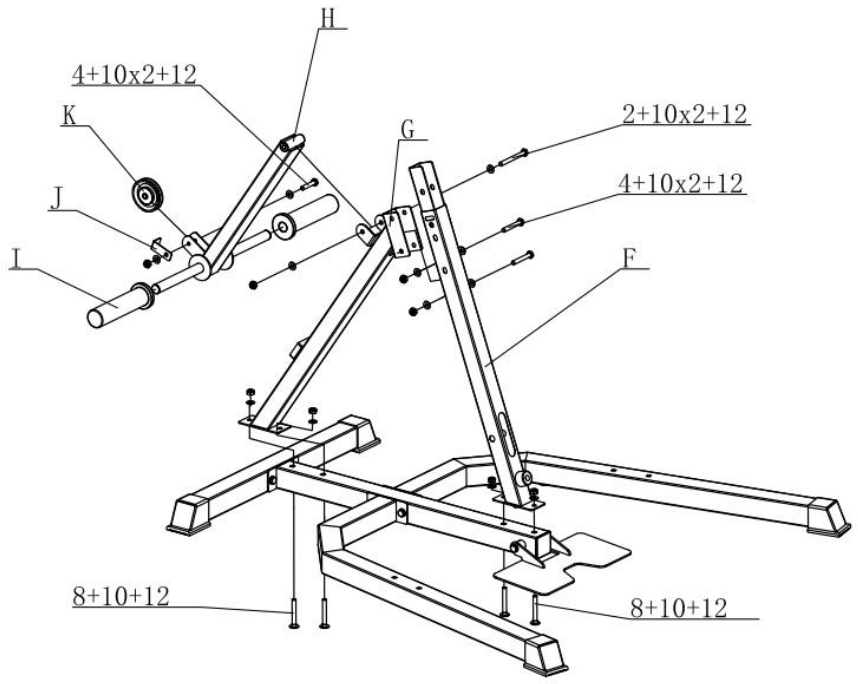



# STEP2:

<p>F</p>  <p>1PCS</p>	<p>G</p>  <p>1PCS</p>	<p>H</p>  <p>1PCS</p>	<p>I</p>  <p>2PCS</p>	<p>J</p>  <p>1PCS</p>
<p>K</p>  <p>1 PCS</p>	<p>2. BOLT (M10×100)</p>  <p>1 PCS</p>	<p>4. BOLT (M10×70)</p>  <p>2 PCS</p>	<p>5. BOLT (M10×50)</p>  <p>1 PCS</p>	<p>8. Carriage BOLT (M10×75)</p>  <p>4 PCS</p>
<p>10. Washer (M10)</p>  <p>12 PCS</p>	<p>12. Locknut (M10)</p>  <p>8 PCS</p>			







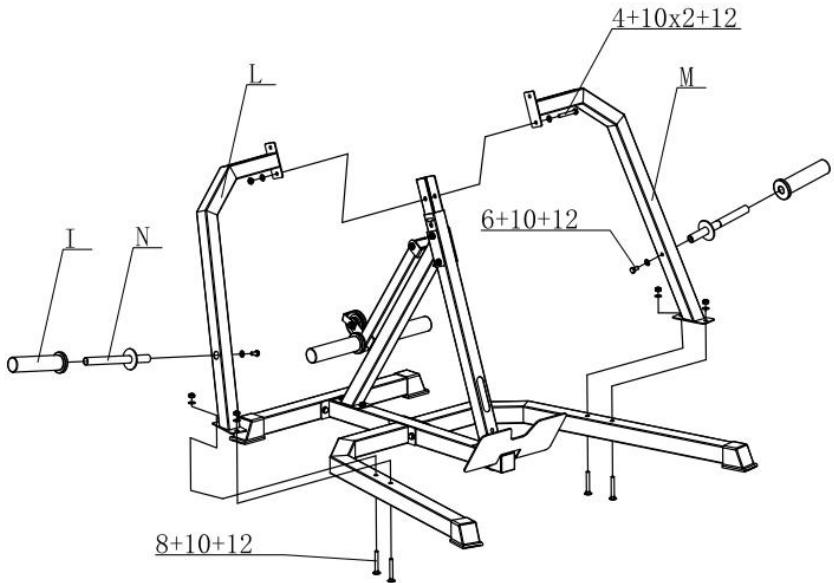



# STEP3:

<p>I</p>  <p>2PCS</p>	<p>L</p>  <p>1PCS</p>	<p>M</p>  <p>1PCS</p>	<p>N</p>  <p>2PCS</p>	<p>4. BOLT (M10×70)</p>  <p>1 PCS</p>
<p>6. BOLT (M10×20)</p>  <p>2 PCS</p>	<p>8. Carriage BOLT (M10×75)</p>  <p>4 PCS</p>	<p>10. Washer (M10)</p>  <p>8 PCS</p>	<p>12. Locknut (M10)</p>  <p>5 PCS</p>	







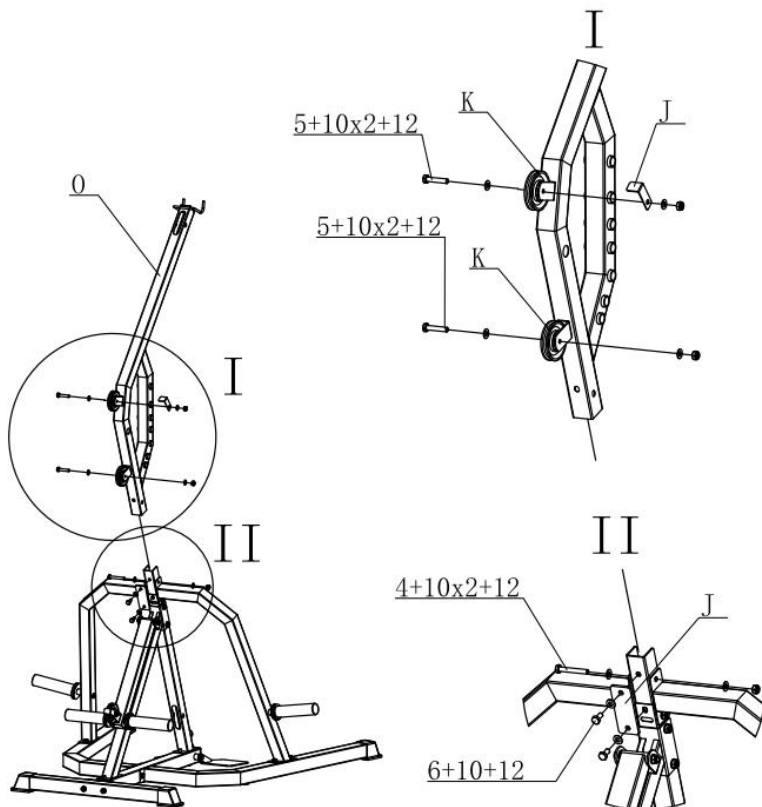







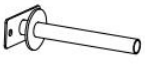

# STEP4:

<p>K</p>  <p>2PCS</p>	<p>J</p>  <p>1PCS</p>	<p>O</p>  <p>1 PCS</p>	<p>P</p>  <p>1 PCS</p>	<p>4. BOLT (M10×70)</p>  <p>1 PCS</p>
<p>5. BOLT (M10×50)</p>  <p>2 PCS</p>	<p>6. BOLT (M10×20)</p>  <p>2 PCS</p>	<p>10. Washer (M10)</p>  <p>8 PCS</p>	<p>12. Locknut (M10)</p>  <p>3 PCS</p>	







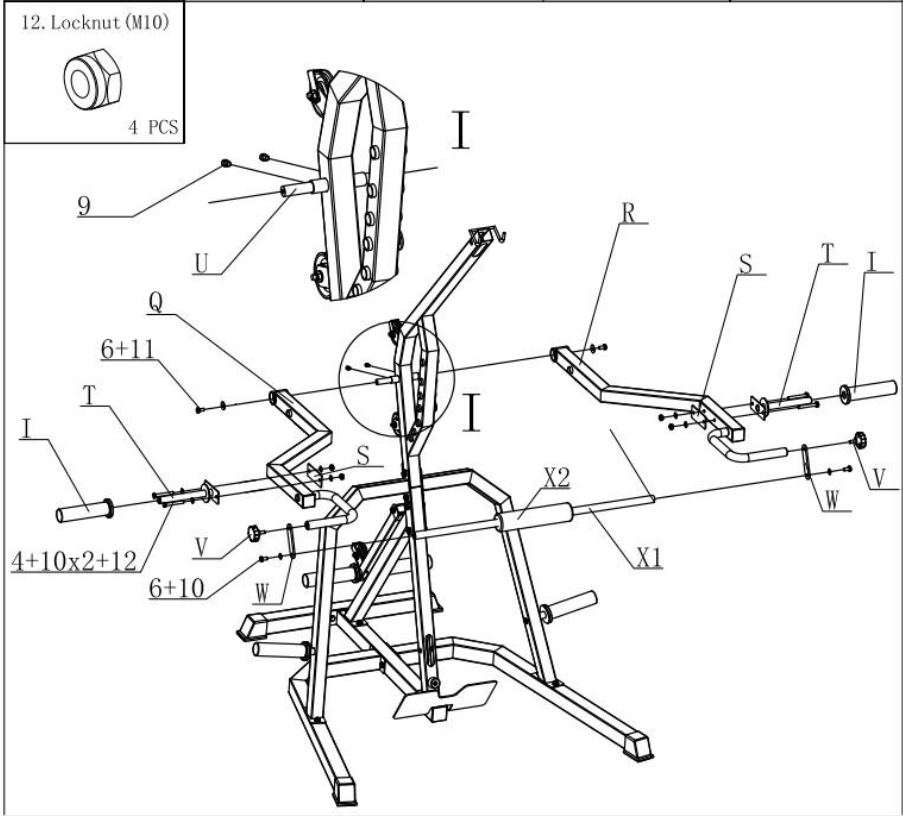





# STEP5:

<p>I</p>  <p>2PCS</p>	<p>Q</p>  <p>1PCS</p>	<p>R</p>  <p>1 PCS</p>	<p>S</p>  <p>2 PCS</p>	<p>T</p>  <p>2 PCS</p>
<p>U</p>  <p>1PCS</p>	<p>V</p>  <p>2PCS</p>	<p>W</p>  <p>2 PCS</p>	<p>X1</p>  <p>1 PCS</p>	<p>X2</p>  <p>1 PCS</p>
<p>4. BOLT (M10×70)</p>  <p>4 PCS</p>	<p>6. BOLT (M10×20)</p>  <p>4 PCS</p>	<p>9. BOLT (M8×16)</p>  <p>2 PCS</p>	<p>10. Washer (M10)</p>  <p>10 PCS</p>	<p>11. Big Washer (M10)</p>  <p>2 PCS</p>



# STEP6:

<p>K</p>  <p>2PCS</p>	<p>Y1</p>  <p>1 PCS</p>	<p>Y2</p>  <p>1 PCS</p>	<p>Y3</p>  <p>3 PCS</p>	<p>Y4</p>  <p>2 PCS</p>
<p>Z</p>  <p>1 PCS</p>	<p>4. BOLT (M10×70)</p>  <p>2 PCS</p>	<p>7. Spacer Sleeve (10)</p>  <p>4 PCS</p>	<p>10. Washer (M10)</p>  <p>4 PCS</p>	<p>12. Locknut (M10)</p>  <p>2 PCS</p>

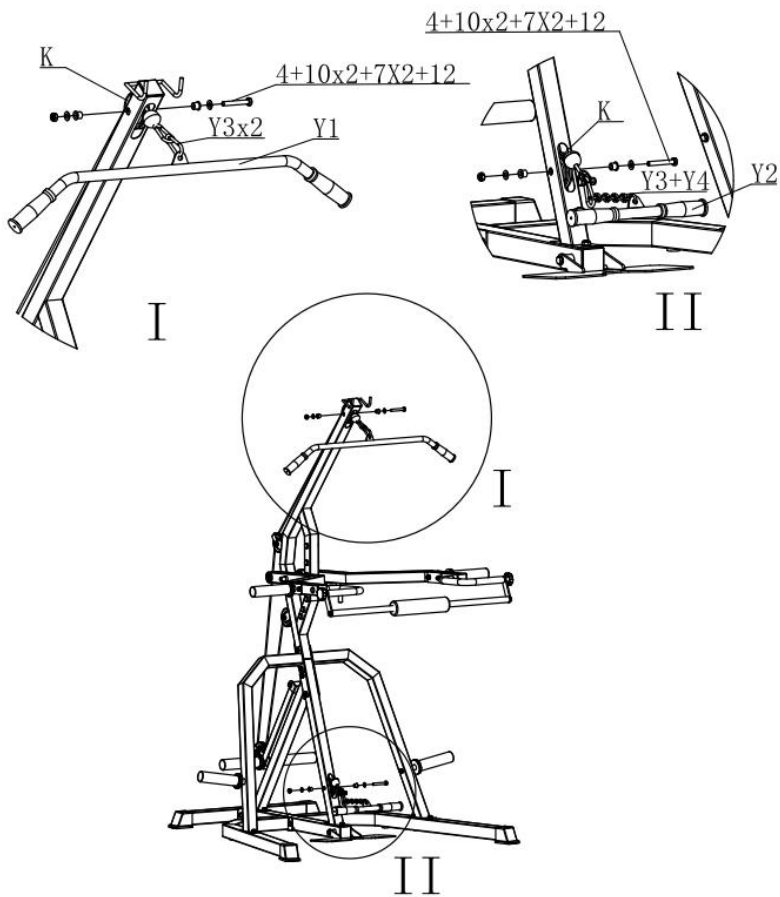

## LINEE GUIDA PER LA MANUTENZIONE E IL CONDIZIONAMENTO

1. Pulizia e manutenzione: pulire lo squat con un panno pulito, morbido e umido. Non esporre la parte in plastica a solventi corrosivi. Rimuovere eventuali macchie di sudore dallo squat dopo ogni utilizzo.

Fare attenzione a non far entrare troppa umidità nello schermo dell'orologio elettronico, poiché ciò potrebbe causare un malfunzionamento del circuito. Evitare la luce solare diretta sugli squat, in particolare sugli schermi degli orologi elettronici, per evitare danni al prodotto. Controllare settimanalmente che viti, dadi e pedali non siano allentati.

2. Conservazione: conservare la macchina per squat in un ambiente asciutto e pulito, lontano dalla portata di bambini e animali domestici.

**3. Nota: non utilizzare per più di 15 minuti alla volta .**

## L'USO SICURO RICHIEDE DI SAPERE

Grazie per aver acquistato i nostri prodotti. L'uso corretto di questo dispositivo è garanzia di sicurezza e salute. È molto importante leggere attentamente il manuale prima di utilizzare questo dispositivo! Solo se questa attrezzatura è installata, mantenuta e utilizzata correttamente, l'allenamento può essere sicuro ed efficace.

1. Questa apparecchiatura è adatta solo per uso interno e domestico. Il massimo il peso e il carico dell'utente sono 120 kg.

2. Questo dispositivo appartiene al grado HC e non è adatto all'uso medico.

3. Prima del montaggio, è necessario comprendere appieno l'elenco delle parti forniti per questa apparecchiatura e installarli in piena conformità con il manuale di istruzioni.

4. Per l'installazione è necessario utilizzare gli strumenti appropriati . Se necessario, chiedi alla seconda persona di assisterti fermandosi insieme .

5. L'attrezzatura per il fitness deve essere posizionata su una superficie piana e antiscivolo per poter essere utilizzata. Se posizionata in uno spazio umido, l'uso a lungo termine dell'attrezzatura sarà influenzato dalla corrosione.
  6. Prima dell'uso, verificare che le parti a vite siano bloccate e assicurarsi che ci sia una distanza di 0,6 metri attorno all'apparecchiatura e che non vi siano dispositivi regolabili in vista.
  7. Controllare regolarmente che le varie parti di collegamento dell'apparecchiatura siano ben serrate e che il loro stato sia normale, al fine di garantire il livello di sicurezza dell'apparecchiatura.
  8. Non utilizzare detergenti corrosivi durante la manutenzione e la pulizia per evitare che il liquido penetri nell'apparecchiatura attraverso la coda o la fessura.
  9. Questo dispositivo è utilizzato da adulti, bambini e animali domestici devono tenersi lontani da questo dispositivo e può essere utilizzato solo sotto la guida di un adulto.
  10. Questa attrezzatura può essere utilizzata da una sola persona alla volta. Si prega di segnalare i possibili pericoli per le persone circostanti, come ad esempio il pericolo di parti in movimento durante l'esercizio.
  11. Indossare indumenti aderenti durante l'attività fisica per evitare che indumenti larghi possano inciampare nelle attrezzature o limitare i movimenti.
  12. Si prega di non fare esercizio fisico prima e dopo i pasti.
  13. Si prega di prestare attenzione ai metodi di esercizio indicati nelle istruzioni.
  14. Consultare il medico di famiglia prima di fare esercizio, che vi dirà che tipo di esercizio e carico di esercizio sono adatti a voi. Un esercizio sbagliato può danneggiare la salute, un allenamento eccessivo può portare a gravi lesioni o alla morte. Se vi sentite storditi , interrompete immediatamente l'allenamento.
- 1 5 , conservare questo manuale e gli strumenti di installazione.

16 , Se avete domande o avete bisogno della nostra assistenza, contattate il nostro servizio post-vendita.

## **Consigli importanti**

1. Seguire le istruzioni di installazione e utilizzare solo le parti configurate con questo dispositivo.
2. In linea di principio, non consideriamo le attrezzature sportive come giocattoli e possono essere utilizzate solo da persone che conoscono le relative conoscenze o che sono state istruite.
3. Se si avvertono vertigini, nausea, dolore al petto o altri sintomi anomali, interrompere immediatamente l'attività fisica e consultare il medico.
4. I bambini e le persone disabili devono utilizzare questa apparecchiatura solo sotto la guida di un operatore qualificato.
5. Si prega di notare che né tu né gli altri dovete introdurre alcuna parte del corpo nell'area sportiva.
6. Nelle parti dell'attrezzatura che possono essere regolate, prestare particolare attenzione alla posizione limite massima contrassegnata.
7. Eseguire solo controlli regolari per verificare l'usura e le parti allentate, al fine di garantire che l'attrezzatura sia in condizioni di alta qualità .

## **Istruzioni di montaggio**

1. Il prodotto deve essere installato con cura da adulti, in caso di incertezza , per favore chiedi esperienza tecnica per aiutarti.
2. Disimballare tutti i materiali di imballaggio, posizionare le varie parti, rendere più chiaro e facile la comprensione dell'assemblaggio, utilizzare il cuscinetto per proteggere la superficie di installazione ed evitare sporco o graffi.
- 3, e quindi secondo l'elenco delle parti , per verificare se le parti sono complete, solo dopo l'installazione è possibile imballare i materiali essere scartato.
4. Prima di iniziare il montaggio, leggere attentamente le istruzioni di

installazione e comprendere lo schema elettrico corrispondente.

5. Si prega di notare che quando si utilizzano utensili e operazioni manuali, potrebbe esserci il rischio di lesioni operative, quindi fare attenzione durante l'installazione del prodotto.

6. Dopo aver assemblato il prodotto secondo le istruzioni, verificare attentamente che viti, dadi e manopole siano installati correttamente e serrati in posizione.

7. Dopo l'installazione, non posizionare lo strumento in modo casuale.

8. Si consiglia di trovare un cuscinetto protettivo (non fornito nel prodotto), posizionato sotto il prodotto per proteggere il pavimento, perché la gomma del prodotto lascia inevitabilmente tracce.

## **Specifica del movimento**

1. Sapevi che un esercizio di resistenza moderato (ad esempio circa 30 minuti, 2 volte a settimana) può migliorare notevolmente la tua salute? La pressione sanguigna, il colesterolo, la glicemia, l'iniziativa e persino l'umore possono essere notevolmente migliorati con una piccola quantità di esercizio. Puoi ridurre la percentuale di grasso corporeo apportando piccole modifiche alla forma del tuo corpo e adattando di conseguenza l'assunzione di nutrienti.

2. L' esercizio dovrebbe sempre iniziare con un riscaldamento. Più è intenso l'allenamento, più è importante riscaldarsi. Il riscaldamento prepara il corpo al carico, stimola il sistema cardiovascolare e protegge i legamenti, tendini e articolazioni da lesioni. Aiuta anche a ridurre il rischio di crampi e lesioni muscolari .



**Produttore:** Shanghaimuxinmuyeyouxiangongsi

**Indirizzo:** Shuangchenglu 803nong11hao1602A-1609shi, baoshanqu, Shanghai 200000 CN.

**Importato in AUS:** SIHAO PTY LTD. 1 ROKEVA STREETEASTWOOD  
Nuovo Galles del Sud 2122 Australia

**Importato negli USA:** Sanven Technology Ltd. Suite 250, 9166 Anaheim  
Luogo, Rancho Cucamonga, CA 91730

<b>UK</b>	<b>REP</b>
-----------	------------

YH CONSULTING LIMITED. C/O YH Consulting  
Limited Office 147, Centurion House, London  
Road, Staines-upon-Thames, Surrey, TW18 4AX

<b>EC</b>	<b>REP</b>
-----------	------------

E-CrossStu GmbH  
Mainzer Landstr.69,  
60329 Frankfurt am Main.



# **VEVOR**

**Affordable. Reliable. Home Improvement.**

## **MÁQUINA DE SENTADILLAS HACK**

**MODELO: HM2901A**

# VEVOR

Affordable. Reliable. Home Improvement.

## HACK SQUAT MACHINE

MODELO: HM2901A

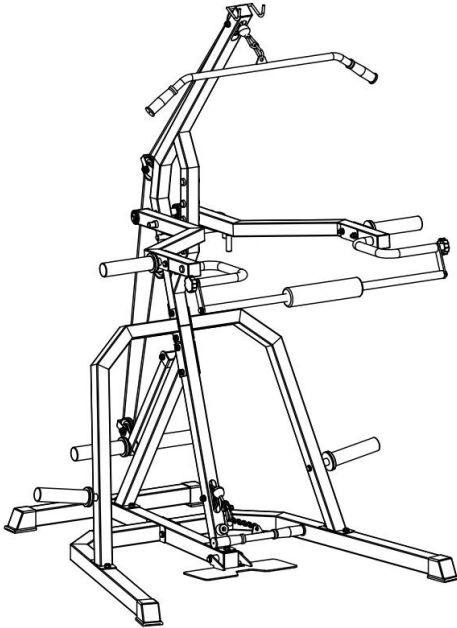

Installation Instruction



Estas son las instrucciones originales; lea atentamente todas las instrucciones del manual antes de utilizarlo. VEVOR se reserva el derecho de interpretar su manual de usuario. La apariencia del producto dependerá del producto que haya recibido. Le rogamos que nos disculpe si no le informamos de nuevo si hay actualizaciones tecnológicas o de software en nuestro producto.

































Advertencia: Para reducir el riesgo de lesiones, el usuario debe leer atentamente el manual de instrucciones.

## LISTA DE VERIFICACIÓN PREVIA AL MONTAJE









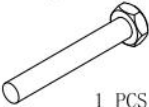
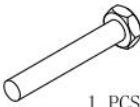

**Asegúrese de incluir todas las piezas antes de comenzar el montaje.**

Anotado: Se han instalado algunos accesorios de tornillos en el producto y es necesario aflojarlos y luego conectarlos.

# PARTS LIST

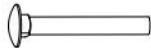







<p>A</p>  <p>1PCS</p>	<p>B</p>  <p>1PCS</p>	<p>C</p>  <p>1PCS</p>	<p>D</p>  <p>1PCS</p>	<p>E</p>  <p>1PCS</p>
<p>F</p>  <p>1PCS</p>	<p>G</p>  <p>1PCS</p>	<p>H</p>  <p>1PCS</p>	<p>I</p>  <p>6PCS</p>	<p>J</p>  <p>2PCS</p>
<p>K</p>  <p>5 PCS</p>	<p>L</p>  <p>1PCS</p>	<p>M</p>  <p>1PCS</p>	<p>N</p>  <p>2PCS</p>	<p>O</p>  <p>1 PCS</p>
<p>P</p>  <p>1 PCS</p>	<p>Q</p>  <p>1PCS</p>	<p>R</p>  <p>1 PCS</p>	<p>S</p>  <p>2 PCS</p>	<p>T</p>  <p>2 PCS</p>
<p>U</p>  <p>1PCS</p>	<p>V</p>  <p>2PCS</p>	<p>W</p>  <p>2 PCS</p>	<p>X1</p>  <p>1 PCS</p>	<p>X2</p>  <p>1 PCS</p>
<p>Y1</p>  <p>1 PCS</p>	<p>Y2</p>  <p>1 PCS</p>	<p>Y3</p>  <p>3 PCS</p>	<p>Y4</p>  <p>1 PCS</p>	<p>Z</p>  <p>1 PCS</p>

# HARDWARE LIST

<p>1. BOLT (M10×135)</p>  <p style="text-align: center;">1 PCS</p>	<p>2. BOLT (M10×100)</p>  <p style="text-align: center;">1 PCS</p>	<p>3. BOLT (M10×80)</p>  <p style="text-align: center;">4 PCS</p>	<p>4. BOLT (M10×70)</p>  <p style="text-align: center;">10 PCS</p>	<p>5. BOLT (M10×50)</p>  <p style="text-align: center;">3 PCS</p>
<p>6. BOLT (M10×20)</p>  <p style="text-align: center;">8 PCS</p>	<p>7. Spacer Sleeve (10)</p>  <p style="text-align: center;">4 PCS</p>	<p>8. Carriage BOLT (M10×75)</p>  <p style="text-align: center;">8 PCS</p>	<p>9. BOLT (M8×16)</p>  <p style="text-align: center;">2 PCS</p>	<p>10. Washer (M10)</p>  <p style="text-align: center;">52 PCS</p>
<p>11. Big Washer (M10)</p>  <p style="text-align: center;">2 PCS</p>	<p>12. Locknut (M10)</p>  <p style="text-align: center;">27 PCS</p>			







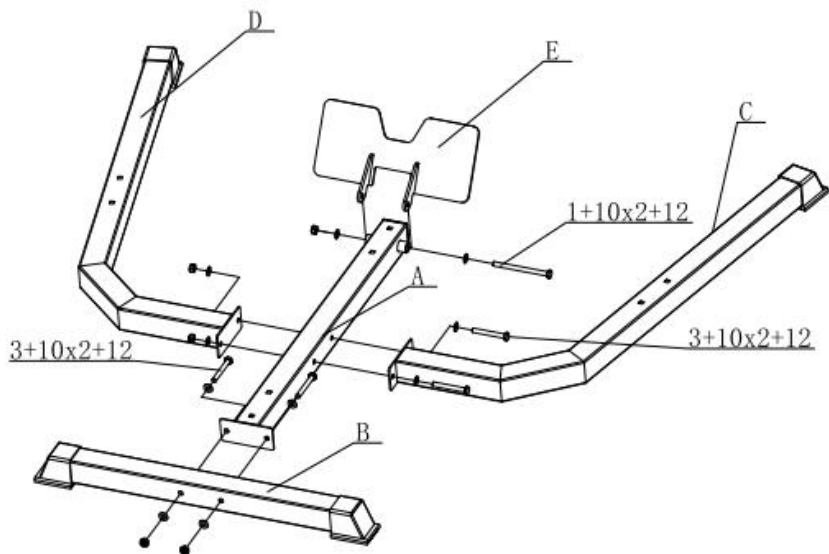

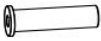

# INSTRUCCIONES DE MONTAJE

## STEP 1:

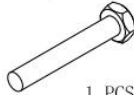
<p>A</p>  <p>1PCS</p>	<p>B</p>  <p>1PCS</p>	<p>C</p>  <p>1PCS</p>	<p>D</p>  <p>1PCS</p>	<p>E</p>  <p>4PCS</p>
<p>1. BOLT (M10 × 135)</p>  <p>1 PCS</p>	<p>3. BOLT (M10 × 80)</p>  <p>4 PCS</p>	<p>10. Washer (M10)</p>  <p>10 PCS</p>	<p>12. Locknut (M10)</p>  <p>5 PCS</p>	







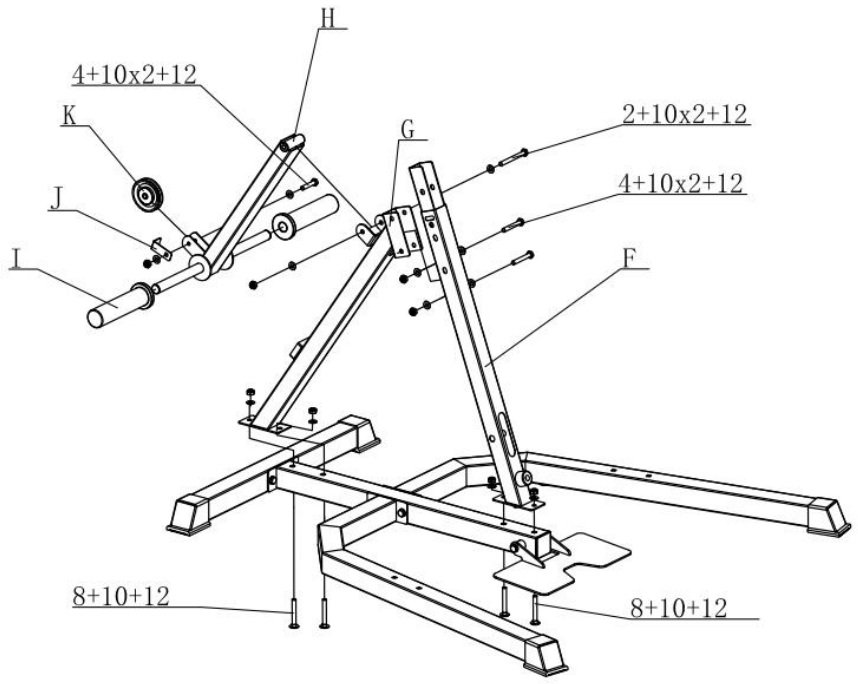



# STEP2:

<p>F</p>  <p>1PCS</p>	<p>G</p>  <p>1PCS</p>	<p>H</p>  <p>1PCS</p>	<p>I</p>  <p>2PCS</p>	<p>J</p>  <p>1PCS</p>
<p>K</p>  <p>1 PCS</p>	<p>2. BOLT (M10×100)</p>  <p>1 PCS</p>	<p>4. BOLT (M10×70)</p>  <p>2 PCS</p>	<p>5. BOLT (M10×50)</p>  <p>1 PCS</p>	<p>8. Carriage BOLT (M10×75)</p>  <p>4 PCS</p>
<p>10. Washer (M10)</p>  <p>12 PCS</p>	<p>12. Locknut (M10)</p>  <p>8 PCS</p>			







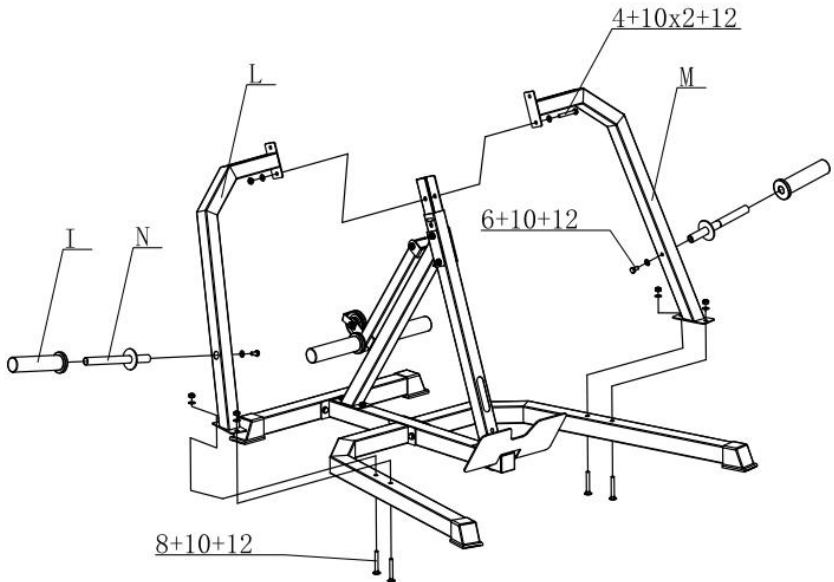



# STEP3:

<p>I</p>  <p>2PCS</p>	<p>L</p>  <p>1PCS</p>	<p>M</p>  <p>1PCS</p>	<p>N</p>  <p>2PCS</p>	<p>4. BOLT (M10×70)</p>  <p>1 PCS</p>
<p>6. BOLT (M10×20)</p>  <p>2 PCS</p>	<p>8. Carriage BOLT (M10×75)</p>  <p>4 PCS</p>	<p>10. Washer (M10)</p>  <p>8 PCS</p>	<p>12. Locknut (M10)</p>  <p>5 PCS</p>	







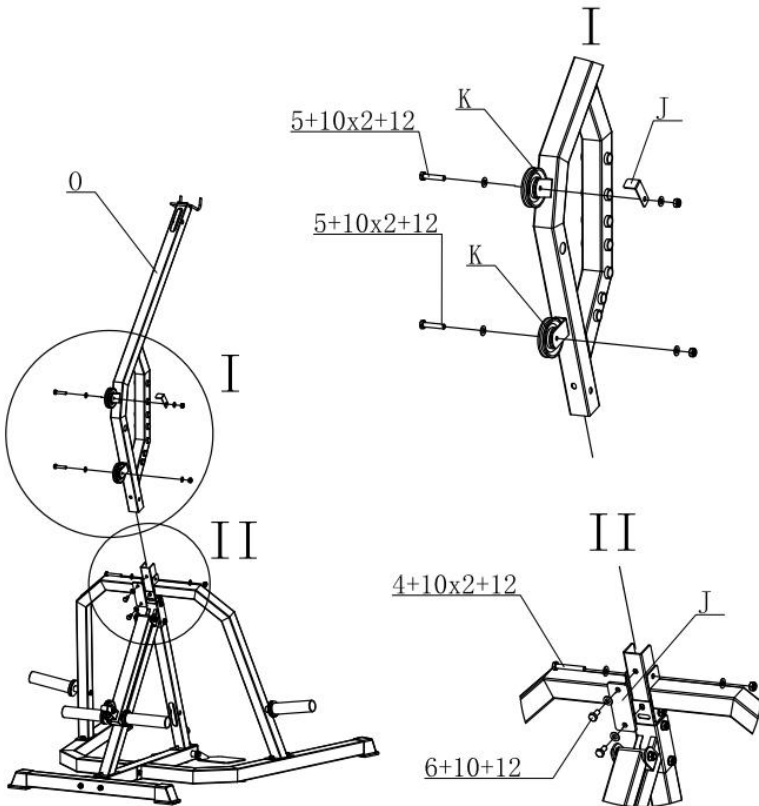









# STEP4:

<p>K</p>  <p>2PCS</p>	<p>J</p>  <p>1PCS</p>	<p>O</p>  <p>1 PCS</p>	<p>P</p>  <p>1 PCS</p>	<p>4. BOLT (M10×70)</p>  <p>1 PCS</p>
<p>5. BOLT (M10×50)</p>  <p>2 PCS</p>	<p>6. BOLT (M10×20)</p>  <p>2 PCS</p>	<p>10. Washer (M10)</p>  <p>8 PCS</p>	<p>12. Locknut (M10)</p>  <p>3 PCS</p>	







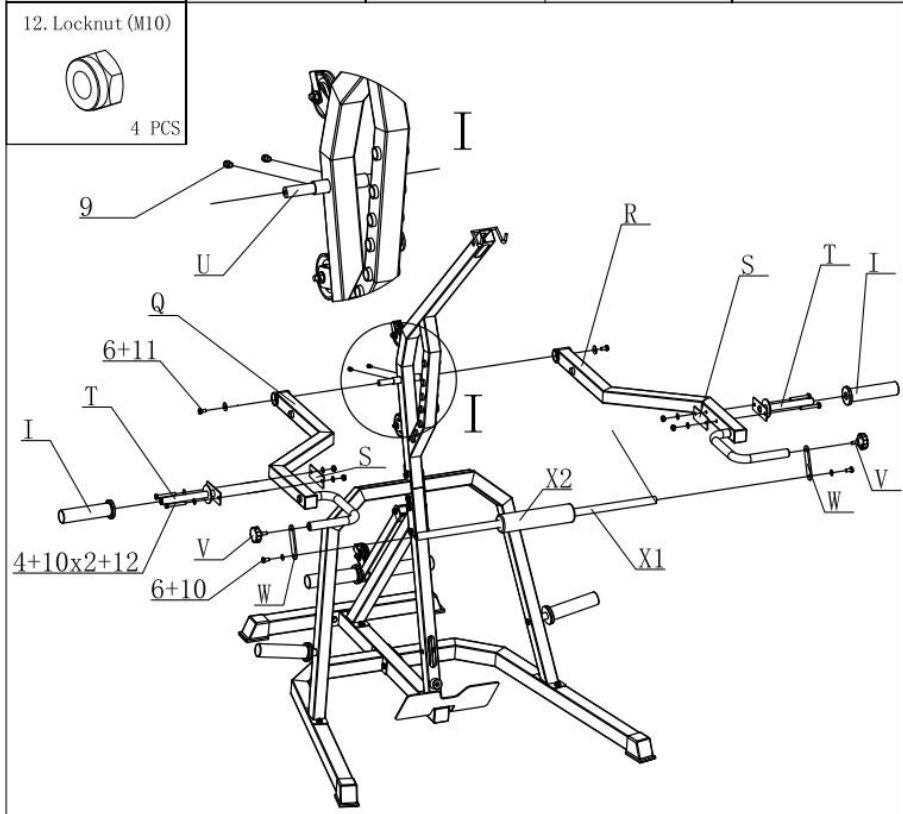





# STEP5:

<p>I</p>  <p>2PCS</p>	<p>Q</p>  <p>1PCS</p>	<p>R</p>  <p>1 PCS</p>	<p>S</p>  <p>2 PCS</p>	<p>T</p>  <p>2 PCS</p>
<p>U</p>  <p>1PCS</p>	<p>V</p>  <p>2PCS</p>	<p>W</p>  <p>2 PCS</p>	<p>X1</p>  <p>1 PCS</p>	<p>X2</p>  <p>1 PCS</p>
<p>4. BOLT (M10×70)</p>  <p>4 PCS</p>	<p>6. BOLT (M10×20)</p>  <p>4 PCS</p>	<p>9. BOLT (M8×16)</p>  <p>2 PCS</p>	<p>10. Washer (M10)</p>  <p>10 PCS</p>	<p>11. Big Washer (M10)</p>  <p>2 PCS</p>



# STEP6:

<p>K</p>  <p>2PCS</p>	<p>Y1</p>  <p>1 PCS</p>	<p>Y2</p>  <p>1 PCS</p>	<p>Y3</p>  <p>3 PCS</p>	<p>Y4</p>  <p>2 PCS</p>
<p>Z</p>  <p>1 PCS</p>	<p>4. BOLT (M10×70)</p>  <p>2 PCS</p>	<p>7. Spacer Sleeve (10)</p>  <p>4 PCS</p>	<p>10. Washer (M10)</p>  <p>4 PCS</p>	<p>12. Locknut (M10)</p>  <p>2 PCS</p>

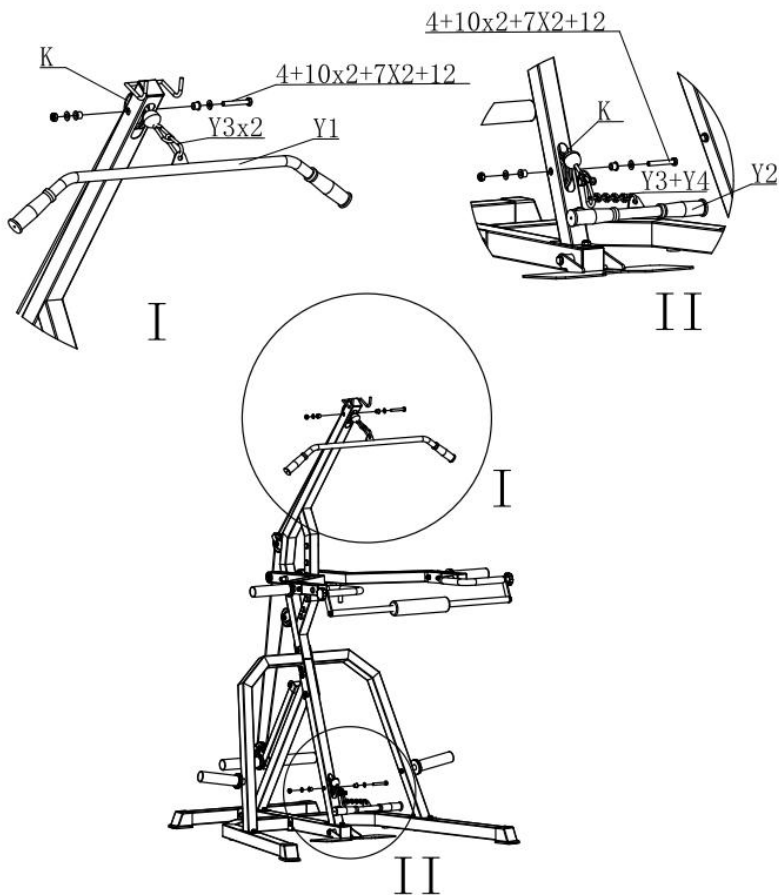

## PAUTAS DE MANTENIMIENTO Y ACONDICIONAMIENTO

1. Limpieza y mantenimiento: Limpie la sentadilla con un paño limpio, suave y húmedo. No exponga la parte de plástico a disolventes corrosivos. Limpie cualquier mancha de sudor que pueda quedar en la sentadilla después de cada uso.

Tenga cuidado de no dejar que la pantalla del reloj electrónico entre en contacto con demasiada humedad, ya que esto podría provocar un mal funcionamiento del circuito. Evite la luz solar directa sobre los relojes, especialmente sobre las pantallas de los relojes electrónicos, para evitar daños en el producto. Revise semanalmente si hay tornillos, tuercas o pedales sueltos.

2. Almacenamiento: mantenga la máquina de sentadillas en un ambiente seco y limpio, lejos de los niños y las mascotas.

**3. Nota: No lo utilice durante más de 15 minutos seguidos .**

## EL USO SEGURO NECESITA SABER

Gracias por adquirir nuestros productos. El uso correcto de este dispositivo garantiza su seguridad y salud. Es fundamental leer el manual detenidamente antes de usarlo. Solo con una instalación, mantenimiento y uso adecuados, el ejercicio será seguro y efectivo.

1. Este equipo solo es apto para uso doméstico en interiores. El máximo El peso del usuario y la carga son 120 kg.

2. Este dispositivo pertenece al grado HC y no es adecuado para uso médico.

3. Antes del montaje, es necesario comprender completamente la lista de piezas. previsto para este equipo, e instálelo en total conformidad con el manual de instrucciones.

4. La instalación requiere utilizar las herramientas adecuadas para su instalación . Si es necesario, pídale a la segunda persona que lo ayude.

estancados juntos .

5. El equipo de fitness debe colocarse sobre una superficie plana y antideslizante para su uso. Si se coloca en un espacio húmedo, el uso a largo plazo del equipo se verá afectado por la corrosión.
6. Verifique si las piezas de los tornillos están bloqueadas antes de usar y asegúrese de que haya una distancia de espacio de 0,6 metros alrededor del equipo y que no haya ningún dispositivo ajustable prominente.
7. Compruebe periódicamente si las distintas piezas de conexión del equipo están bien apretadas y si su estado es normal, para garantizar el nivel de seguridad del equipo.
8. No utilice agentes de limpieza corrosivos durante el mantenimiento y la limpieza para evitar que entre líquido en el equipo a través de la cola o el espacio.
9. Este dispositivo es utilizado por adultos, los niños y las mascotas deben mantenerse alejados de él y solo pueden operarse bajo la supervisión de adultos.
10. Este equipo solo puede ser utilizado por una persona a la vez. Por favor, señale los posibles peligros a las personas que le rodean, como el peligro de las piezas móviles durante el ejercicio.
11. Use ropa que le quede bien al hacer ejercicio para evitar que la ropa suelta se tropiece con el equipo o restrinja el movimiento.
12. Por favor, no haga ejercicio antes y después de las comidas.
13. Preste atención a los métodos de ejercicio en las instrucciones.
14. Consulte a su médico de cabecera antes de hacer ejercicio, él le dirá qué tipo de ejercicio y carga de ejercicio es adecuado para usted. El ejercicio incorrecto puede dañar su salud, el entrenamiento excesivo puede provocar lesiones graves o la muerte. Si se siente mareado , deje de entrenar inmediatamente.
- 1 5 , conserve este manual y las herramientas de instalación.
- 1 6 , Si tiene alguna pregunta o necesita nuestra ayuda, comuníquese con nuestro departamento de servicio posventa.

## **Consejos importantes**

1. Siga las instrucciones de instalación y utilice únicamente las piezas configuradas con este dispositivo.
2. En principio, no consideramos los equipos deportivos como juguetes y solo pueden ser utilizados por personas que tengan los conocimientos pertinentes o hayan recibido orientación.
3. Si experimenta mareos, náuseas, dolor en el pecho u otros síntomas anormales, deje de hacer ejercicio inmediatamente y consulte a su médico.
4. Los niños y las personas discapacitadas solo deben utilizar este equipo bajo la guía de un operador capacitado.
5. Tenga en cuenta que usted y otras personas no deben introducir ninguna parte del cuerpo en el área deportiva.
6. En las partes del equipo que se puedan ajustar, preste especial atención a la posición del límite máximo marcada.
7. Solo se deben realizar inspecciones periódicas para detectar desgaste y piezas sueltas, a fin de garantizar que el equipo se encuentra en un estado de alta calidad .

## **Instrucciones de montaje**

1. El producto debe ser instalado con cuidado por adultos. En caso de duda , Por favor, solicite experiencia técnica para ayudar.
2. Desempaque todos los materiales de embalaje, coloque las distintas piezas, haga que sea más claro y fácil de entender el ensamblaje, use la almohadilla para proteger la superficie de instalación y evitar la suciedad o los rayones.
3. Luego, de acuerdo con la lista de piezas , verifique si las piezas están completas. Solo después de la instalación se pueden empaquetar los materiales. ser descartado.
4. Antes de comenzar el montaje, lea atentamente las instrucciones de

instalación y comprenda el diagrama esquemático correspondiente.

5. Tenga en cuenta que al utilizar herramientas y realizar operaciones manuales, puede existir riesgo de sufrir lesiones, así que tenga cuidado al instalar el producto.

6. Después de ensamblar el producto según las instrucciones, verifique cuidadosamente si los tornillos, tuercas y perillas están instalados correctamente y apretados en su lugar.

7. Después de la instalación, no coloque la herramienta al azar.

8. Se recomienda que encuentre una almohadilla protectora (no incluida en el producto), colocada debajo del producto para proteger el piso, porque la goma del producto inevitablemente deja rastros.

## **Especificación de movimiento**

1. ¿Sabías que el ejercicio de resistencia moderado (por ejemplo, unos 30 minutos, 2 veces por semana) puede mejorar considerablemente tu salud? Tu presión arterial, colesterol, azúcar en sangre, iniciativa e incluso tu estado de ánimo pueden mejorar notablemente con una pequeña cantidad de ejercicio. Puedes reducir tu porcentaje de grasa corporal haciendo cambios moderados en tu figura y ajustando tu ingesta de nutrientes según corresponda.

2. El ejercicio siempre debe comenzar con un calentamiento. Cuanto más intenso sea el entrenamiento, más importante es el calentamiento. El calentamiento prepara el cuerpo para la carga, estimula el sistema cardiovascular y protege los ligamentos.

Protege los tendones y las articulaciones de lesiones. También ayuda a reducir el riesgo de calambres y lesiones musculares .



**Fabricante:** Shanghaimuxinmuyeyouxiangongsi

**Dirección:** Shuangchenglu 803nong11hao1602A-1609shi, baoshanqu, Shanghai 200000 CN.

**Importado a AUS:** SIHAO PTY LTD. 1 ROKEVA STREET, EASTWOOD NSW 2122 Australia

**Importado a EE. UU.:** Sanven Technology Ltd. Suite 250, 9166 Anaheim Lugar, Rancho Cucamonga, CA 91730

<b>UK</b>	<b>REP</b>
-----------	------------

YH CONSULTING LIMITED. C/O YH Consulting Limited Office 147, Centurion House, London Road, Staines-upon-Thames, Surrey, TW18 4AX

<b>EC</b>	<b>REP</b>
-----------	------------

E-CrossStu GmbH  
Mainzer Landstr.69,  
60329 Frankfurt am Main.



# **VEVOR**

**Affordable. Reliable. Home Improvement.**

## **MASZYNA DO PRZYSIADÓW HACK**

**MODEL: HM2901A**

# VEVOR

Affordable. Reliable. Home Improvement.

## HACK SQUAT MACHINE

MODEL: HM2901A

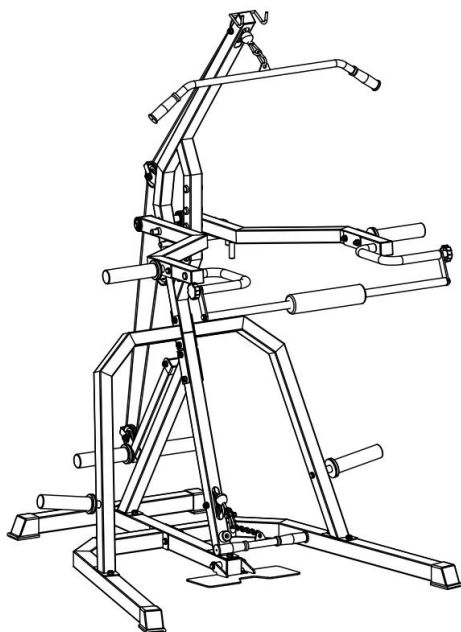

Installation Instruction



To jest oryginalna instrukcja obsługi. Przed użyciem prosimy o dokładne zapoznanie się z treścią instrukcji. Firma VEVOR zastrzega sobie prawo do jednoznacznej interpretacji niniejszej instrukcji obsługi. Wygląd produktu zależy od stanu, w jakim go otrzymali Państwo. Prosimy o wyrozumiałość, ale nie będziemy Państwa ponownie informować o aktualizacjach technologicznych lub oprogramowania naszego produktu.

























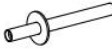



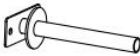

Ostrzeżenie: Aby zminimalizować ryzyko obrażeń, użytkownik powinien uważnie przeczytać instrukcję obsługi.

## LISTA KONTROLNA PRZED MONTAŻEM









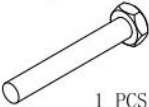
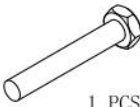

**Przed rozpoczęciem montażu należy upewnić się, że dołączone zostały wszystkie części.**

Znakomity: Do produktu zostały przymocowane niektóre elementy śrubowe, które należy poluzować, a następnie ponownie przykręcić.

# PARTS LIST

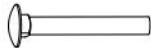







A  1PCS	B  1PCS	C  1PCS	D  1PCS	E  1PCS
F  1PCS	G  1PCS	H  1PCS	I  6PCS	J  2PCS
K  5 PCS	L  1PCS	M  1PCS	N  2PCS	O  1 PCS
P  1 PCS	Q  1PCS	R  1 PCS	S  2 PCS	T  2 PCS
U  1PCS	V  2PCS	W  2 PCS	X1  1 PCS	X2  1 PCS
Y1  1 PCS	Y2  1 PCS	Y3  3 PCS	Y4  1 PCS	Z  1 PCS

# HARDWARE LIST

<p>1. BOLT (M10×135)</p>  <p style="text-align: center;">1 PCS</p>	<p>2. BOLT (M10×100)</p>  <p style="text-align: center;">1 PCS</p>	<p>3. BOLT (M10×80)</p>  <p style="text-align: center;">4 PCS</p>	<p>4. BOLT (M10×70)</p>  <p style="text-align: center;">10 PCS</p>	<p>5. BOLT (M10×50)</p>  <p style="text-align: center;">3 PCS</p>
<p>6. BOLT (M10×20)</p>  <p style="text-align: center;">8 PCS</p>	<p>7. Spacer Sleeve (10)</p>  <p style="text-align: center;">4 PCS</p>	<p>8. Carriage BOLT (M10×75)</p>  <p style="text-align: center;">8 PCS</p>	<p>9. BOLT (M8×16)</p>  <p style="text-align: center;">2 PCS</p>	<p>10. Washer (M10)</p>  <p style="text-align: center;">52 PCS</p>
<p>11. Big Washer (M10)</p>  <p style="text-align: center;">2 PCS</p>	<p>12. Locknut (M10)</p>  <p style="text-align: center;">27 PCS</p>			







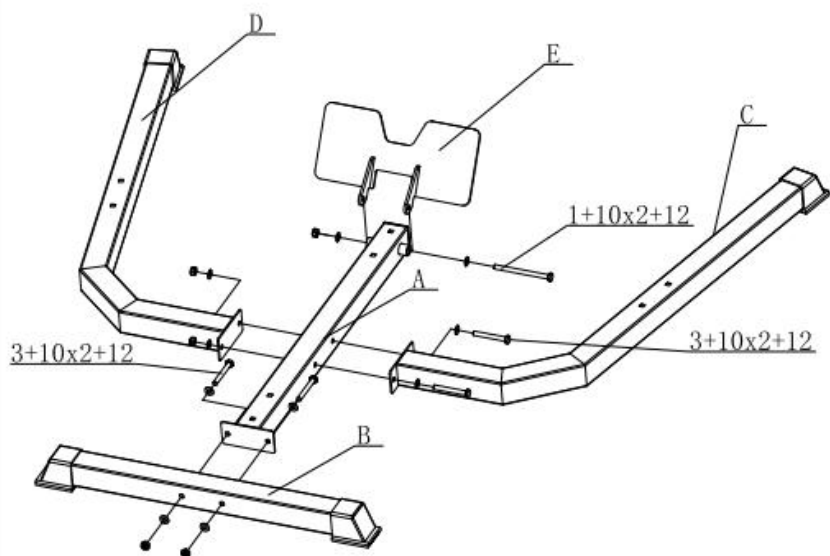

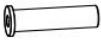

# INSTRUKCJA MONTAŻU

## STEP 1:

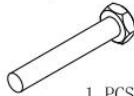
<p>A</p>  <p>1PCS</p>	<p>B</p>  <p>1PCS</p>	<p>C</p>  <p>1PCS</p>	<p>D</p>  <p>1PCS</p>	<p>E</p>  <p>4PCS</p>
<p>1. BOLT (M10 × 135)</p>  <p>1 PCS</p>	<p>3. BOLT (M10 × 80)</p>  <p>4 PCS</p>	<p>10. Washer (M10)</p>  <p>10 PCS</p>	<p>12. Locknut (M10)</p>  <p>5 PCS</p>	







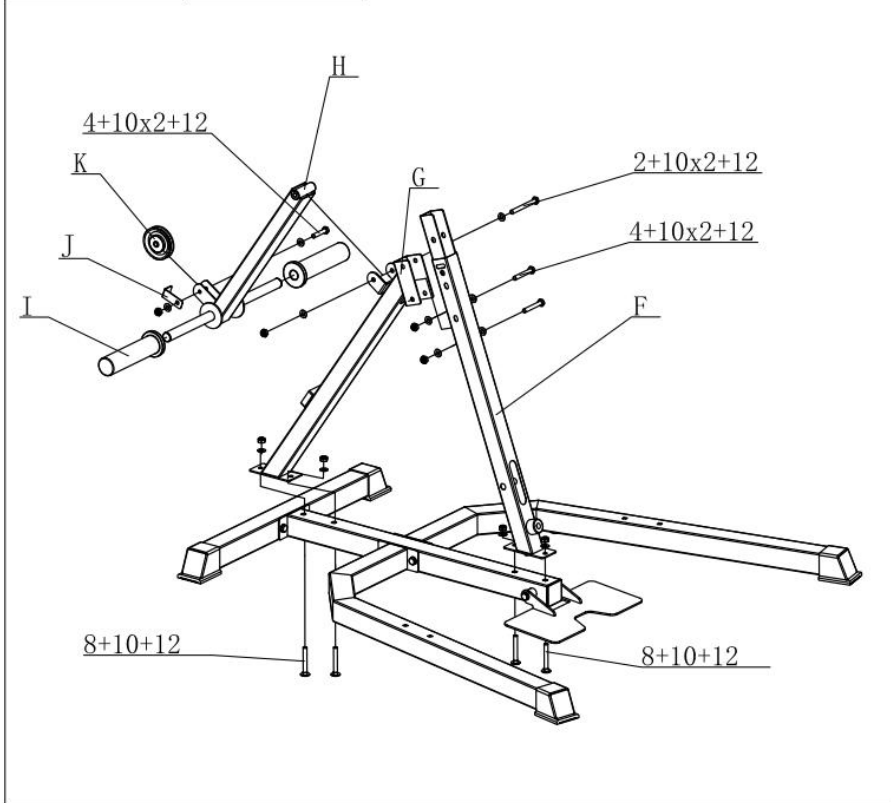



# STEP2:

<p>F</p>  <p>1PCS</p>	<p>G</p>  <p>1PCS</p>	<p>H</p>  <p>1PCS</p>	<p>I</p>  <p>2PCS</p>	<p>J</p>  <p>1PCS</p>
<p>K</p>  <p>1 PCS</p>	<p>2. BOLT (M10×100)</p>  <p>1 PCS</p>	<p>4. BOLT (M10×70)</p>  <p>2 PCS</p>	<p>5. BOLT (M10×50)</p>  <p>1 PCS</p>	<p>8. Carriage BOLT (M10×75)</p>  <p>4 PCS</p>
<p>10. Washer (M10)</p>  <p>12 PCS</p>	<p>12. Locknut (M10)</p>  <p>8 PCS</p>			







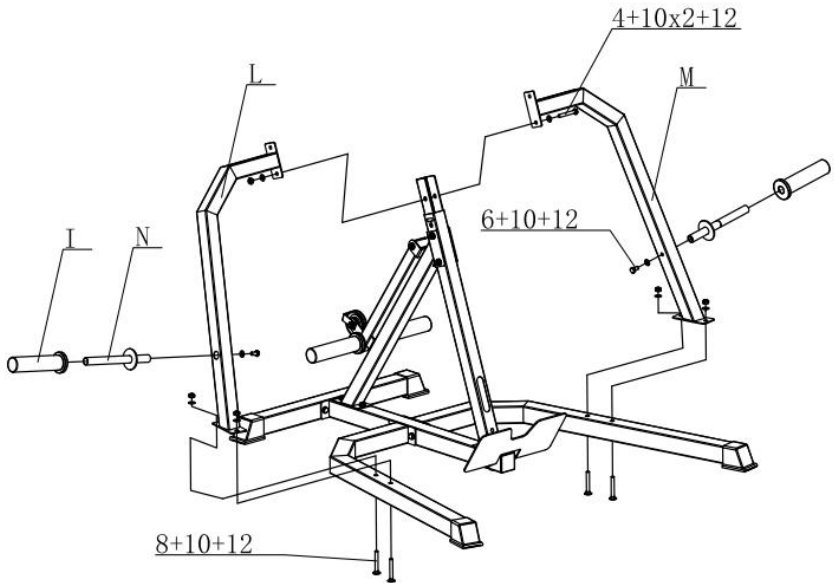



# STEP3:

<p>I</p>  <p>2PCS</p>	<p>L</p>  <p>1PCS</p>	<p>M</p>  <p>1PCS</p>	<p>N</p>  <p>2PCS</p>	<p>4. BOLT (M10×70)</p>  <p>1 PCS</p>
<p>6. BOLT (M10×20)</p>  <p>2 PCS</p>	<p>8. Carriage BOLT (M10×75)</p>  <p>4 PCS</p>	<p>10. Washer (M10)</p>  <p>8 PCS</p>	<p>12. Locknut (M10)</p>  <p>5 PCS</p>	







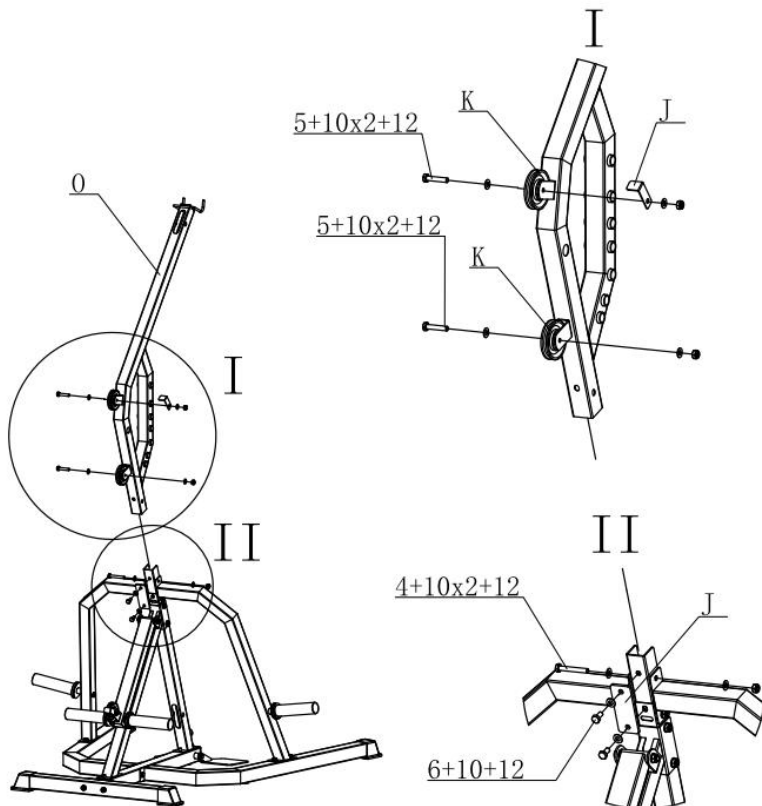







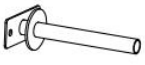

# STEP4:

<p>K</p>  <p>2PCS</p>	<p>J</p>  <p>1PCS</p>	<p>O</p>  <p>1 PCS</p>	<p>P</p>  <p>1 PCS</p>	<p>4. BOLT (M10×70)</p>  <p>1 PCS</p>
<p>5. BOLT (M10×50)</p>  <p>2 PCS</p>	<p>6. BOLT (M10×20)</p>  <p>2 PCS</p>	<p>10. Washer (M10)</p>  <p>8 PCS</p>	<p>12. Locknut (M10)</p>  <p>3 PCS</p>	







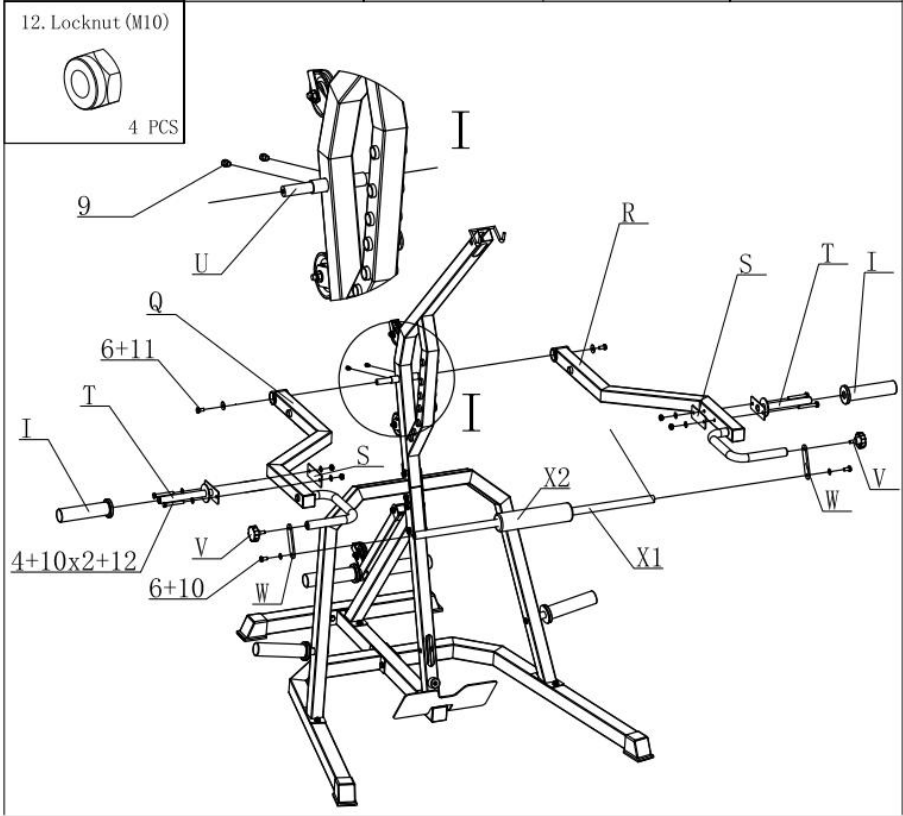





# STEP5:

<p>I</p>  <p>2PCS</p>	<p>Q</p>  <p>1PCS</p>	<p>R</p>  <p>1 PCS</p>	<p>S</p>  <p>2 PCS</p>	<p>T</p>  <p>2 PCS</p>
<p>U</p>  <p>1PCS</p>	<p>V</p>  <p>2PCS</p>	<p>W</p>  <p>2 PCS</p>	<p>X1</p>  <p>1 PCS</p>	<p>X2</p>  <p>1 PCS</p>
<p>4. BOLT (M10×70)</p>  <p>4 PCS</p>	<p>6. BOLT (M10×20)</p>  <p>4 PCS</p>	<p>9. BOLT (M8×16)</p>  <p>2 PCS</p>	<p>10. Washer (M10)</p>  <p>10 PCS</p>	<p>11. Big Washer (M10)</p>  <p>2 PCS</p>



# STEP6:

<p>K</p>  <p>2PCS</p>	<p>Y1</p>  <p>1 PCS</p>	<p>Y2</p>  <p>1 PCS</p>	<p>Y3</p>  <p>3 PCS</p>	<p>Y4</p>  <p>2 PCS</p>
<p>Z</p>  <p>1 PCS</p>	<p>4. BOLT (M10×70)</p>  <p>2 PCS</p>	<p>7. Spacer Sleeve (10)</p>  <p>4 PCS</p>	<p>10. Washer (M10)</p>  <p>4 PCS</p>	<p>12. Locknut (M10)</p>  <p>2 PCS</p>

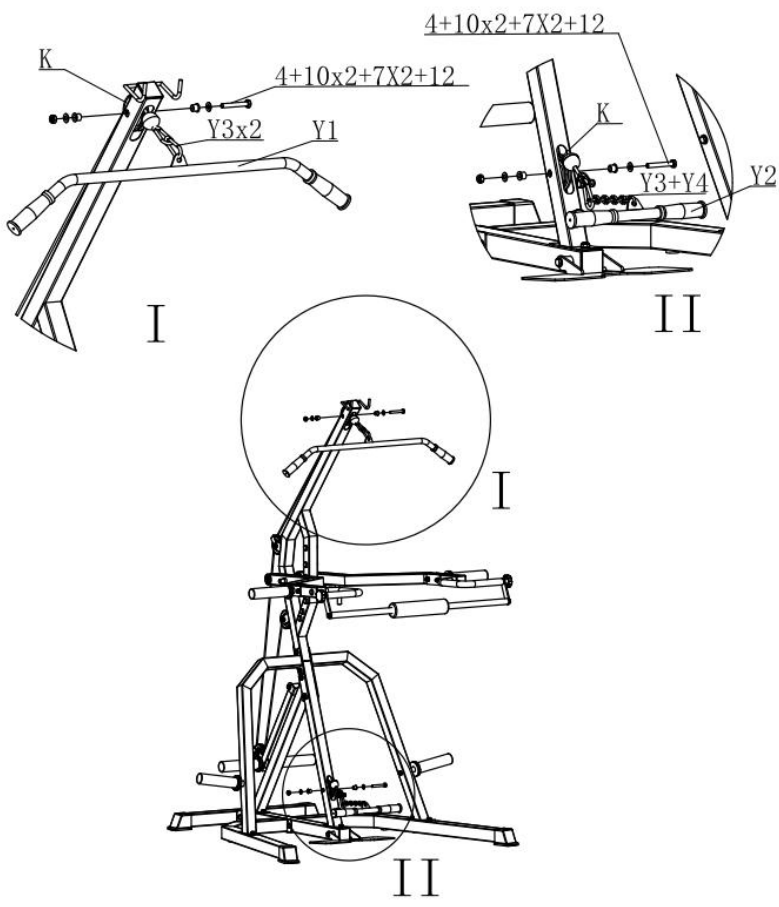

## WYTYCZNE DOTYCZĄCE KONSERWACJI I KONDYCJONOWANIA

1. Czyszczenie i konserwacja: Przecieraj siedzisko czystą, miękką, wilgotną ściereczką. Nie wystawiaj plastikowej części na działanie żrących rozpuszczalników. Po każdym użyciu wytrzyj wszelkie plamy potu, które mogą pozostać na siedzisku.

Uważaj, aby nie dopuścić do kontaktu zbyt dużej ilości wilgoci z ekranem zegarka elektronicznego, ponieważ może to spowodować awarię układu. Unikaj bezpośredniego światła słonecznego podczas przysiadów, zwłaszcza na ekranach zegarków elektronicznych, aby uniknąć uszkodzenia produktu. Co tydzień sprawdzaj, czy śruby, nakrętki i pedały nie są poluzowane.

2. Przechowywanie: Przechowuj maszynę do przysiadów w suchym i czystym miejscu, z dala od dzieci i zwierząt domowych.

**3. Uwaga: Nie stosować dłużej niż 15 minut na raz .**

## BEZPIECZNE UŻYTKOWANIE WYMAGA ZNAJOMOŚCI

Dziękujemy za zakup naszych produktów. Prawidłowe użytkowanie tego urządzenia jest gwarancją Państwa bezpieczeństwa i zdrowia. Bardzo ważne jest, aby uważnie przeczytać instrukcję przed użyciem tego urządzenia! Tylko wtedy, gdy sprzęt jest prawidłowo zainstalowany, konserwowany i użytkowany, ćwiczenia będą bezpieczne i efektywne.

1. To urządzenie nadaje się wyłącznie do użytku domowego, w pomieszczeniach zamkniętych. Maksymalna Maksymalna waga użytkownika i obciążenie wynosi 120 kg.
2. To urządzenie jest urządzeniem klasy HC i nie nadaje się do użytku medycznego.
3. Przed montażem należy dokładnie zapoznać się z listą części przewidziane dla tego sprzętu i zainstaluj je zgodnie z instrukcją obsługi.
4. Do instalacji potrzebne są odpowiednie narzędzia . W razie potrzeby

poproś drugą osobę o pomoc w razem stoją .

5. Sprzęt do ćwiczeń należy ustawić na płaskim, antypoślizgowym podłożu. Jeśli sprzęt zostanie umieszczony w wilgotnym miejscu, długotrwałe użytkowanie będzie narażone na korozję.

6. Przed użyciem należy sprawdzić, czy części śrubowe są zablokowane, a także upewnić się, że wokół urządzenia zachowano odstęp co najmniej 0,6 metra i że nie ma żadnych widocznych elementów regulowanych.

7. Regularnie sprawdzaj, czy różne elementy połączeniowe urządzenia są dobrze dokręcone i czy ich stan jest prawidłowy, aby zapewnić odpowiedni poziom bezpieczeństwa urządzenia.

8. Podczas konserwacji i czyszczenia nie należy używać żrących środków czyszczących, aby zapobiec przedostawaniu się cieczy do urządzenia przez otwór lub szczelinę.

9. Z urządzenia mogą korzystać wyłącznie osoby dorosłe. Dzieci i zwierzęta domowe nie powinny zbliżać się do urządzenia. Urządzenie może być obsługiwane wyłącznie pod nadzorem osób dorosłych.

10. Z tego sprzętu może korzystać jednocześnie tylko jedna osoba. Proszę zwrócić uwagę na możliwe zagrożenia dla osób znajdujących się w pobliżu, na przykład niebezpieczeństwo związane z ruchomymi częściami podczas ćwiczeń.

11. Podczas ćwiczeń należy nosić dobrze dopasowane ubranie, aby luźne ubranie nie objało się o sprzęt i nie ograniczało ruchów.

12. Nie ćwicz przed i po posiłkach.

13. Proszę zwrócić uwagę na metody ćwiczeń podane w instrukcji.

14. Przed rozpoczęciem ćwiczeń skonsultuj się z lekarzem rodzinnym. On powie Ci, jaki rodzaj ćwiczeń i obciążenie są dla Ciebie odpowiednie. Niewłaściwe ćwiczenia mogą zaszkodzić Twojemu zdrowiu, nadmierne treningi mogą prowadzić do poważnych obrażeń lub śmierci. Jeśli poczujesz zawroty głowy , natychmiast przerwij trening.

1 5 , proszę zachować tę instrukcję i narzędzia instalacyjne.

1 6 Jeśli masz jakiegokolwiek pytania lub potrzebujesz naszej pomocy,

skontaktuj się z naszym działem obsługi posprzedażowej.

## **Ważna rada**

1. Postępuj zgodnie z instrukcją instalacji i używaj wyłącznie części skonfigurowanych dla tego urządzenia.
2. Zasadniczo nie uważamy sprzętu sportowego za zabawkę i mogą go używać wyłącznie osoby posiadające odpowiednią wiedzę lub odpowiednio przeszkolone.
3. Jeśli odczuwasz zawroty głowy, nudności, ból w klatce piersiowej lub inne nietypowe objawy, natychmiast przerwij ćwiczenia i skonsultuj się z lekarzem.
4. Dzieci i osoby niepełnosprawne powinny używać tego sprzętu wyłącznie pod nadzorem wykwalifikowanego operatora.
5. Należy pamiętać, że Tobie i innym osobom nie wolno wkładać żadnej części ciała na teren przeznaczony do uprawiania sportu.
6. W przypadku części urządzenia , które można regulować, należy zwrócić szczególną uwagę na zaznaczone położenie maksymalnego limitu.
7. Należy przeprowadzać jedynie regularne kontrole zużycia i luźnych części, aby mieć pewność, że sprzęt jest w dobrym stanie .

## **Instrukcja montażu**

1. Produkt musi być instalowany ostrożnie przez osoby dorosłe, w razie wątpliwości , Proszę zwrócić się o pomoc do doświadczonych techników.
2. Rozpakuj wszystkie materiały opakowaniowe, rozłóż poszczególne części, aby montaż był bardziej przejrzysty i łatwiejszy do zrozumienia, użyj podkładki, aby chronić powierzchnię instalacyjną i uniknąć zabrudzeń lub zarysowań.
3. Następnie, zgodnie z listą części , należy sprawdzić, czy części są kompletne. Dopiero po instalacji można przystąpić do pakowania materiałów. zostać odrzuconym.

4. Przed rozpoczęciem montażu należy uważnie przeczytać instrukcję instalacji i zapoznać się z odpowiednim schematem.
5. Należy pamiętać, że podczas korzystania z narzędzi i obsługi ręcznej istnieje ryzyko odniesienia obrażeń, dlatego należy zachować ostrożność podczas instalacji produktu.
6. Po złożeniu produktu zgodnie z instrukcją należy dokładnie sprawdzić, czy śruby, nakrętki i pokrętła są prawidłowo zamontowane i dokręcone.
7. Po instalacji nie należy umieszczać narzędzia w przypadkowym miejscu.
8. Zaleca się, aby pod produktem umieścić podkładkę ochronną (nie jest dołączona do produktu) w celu zabezpieczenia podłogi, ponieważ guma produktu nieuchronnie pozostawia ślady.

## **Specyfikacja ruchu**

1. Czy wiesz, że umiarkowany wysiłek fizyczny (np. około 30 minut, 2 razy w tygodniu) może znacznie poprawić Twoje zdrowie? Twoje ciśnienie krwi, poziom cholesterolu, poziom cukru we krwi, inicjatywa, a nawet nastrój – wszystko to może ulec znacznej poprawie dzięki niewielkiej ilości ćwiczeń. Możesz zmniejszyć procent tkanki tłuszczowej, wprowadzając niewielkie zmiany w sylwetce i odpowiednio dostosowując spożycie składników odżywczych.
2. Ćwiczenia zawsze należy rozpoczynać rozgrzewką . Im trudniejszy trening, tym ważniejsza jest rozgrzewka. Rozgrzewka przygotowuje ciało do wysiłku, stymuluje układ sercowo-naczyniowy i chroni więzadła. ścięgna i stawy przed urazami. Pomaga również zmniejszyć ryzyko skurczów i urazów mięśni .



**Producent:** Shanghaimuxinmuyeyouxiangongsi

**Adres:** Shuangchenglu 803nong11hao1602A-1609shi, baoshanqu, szanghaj 200000 CN.

**Importowane do AUS:** SIHAO PTY LTD. 1 ROKEVA

STREETEASTWOOD

NSW 2122 Australia

**Importowane do USA:** Sanven Technology Ltd. Suite 250, 9166 Anaheim Miejsce, Rancho Cucamonga, CA 91730

<b>UK</b>	<b>REP</b>
-----------	------------

YH CONSULTING LIMITED. C/O YH Consulting  
Limited Office 147, Centurion House, London  
Road, Staines-upon-Thames, Surrey, TW18 4AX

<b>EC</b>	<b>REP</b>
-----------	------------

E-CrossStu GmbH  
Mainzer Landstr.69,  
60329 Frankfurt am Main.



# **VEVOR**

**Affordable. Reliable. Home Improvement.**

## **HACK SQUAT MACHINE**

**MODEL: HM2901A**

# VEVOR

Affordable. Reliable. Home Improvement.

## HACK SQUAT MACHINE

MODEL: HM2901A

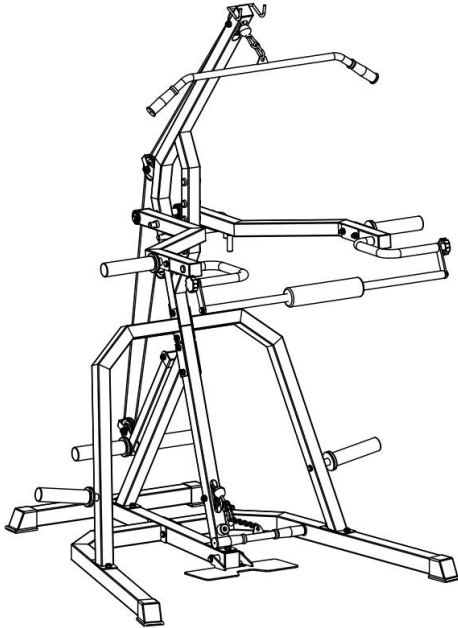

Installation Instruction



Dit is de originele handleiding. Lees alle instructies zorgvuldig door voordat u het product gebruikt. VEVOR behoudt zich het recht voor om de gebruiksaanwijzing duidelijk te interpreteren. Het uiterlijk van het product is afhankelijk van het product dat u hebt ontvangen. Neemt u het ons niet kwalijk dat we u niet meer op de hoogte stellen van eventuele technologische of software-updates voor ons product.

































Waarschuwing: om het risico op letsel te verminderen, moet de gebruiker de gebruiksaanwijzing zorgvuldig lezen.

## CONTROLELIJST VOOR MONTAGE









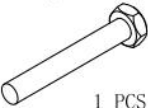
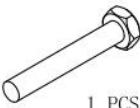

**Zorg ervoor dat alle onderdelen aanwezig zijn voordat u met de montage begint.**

Opgemerkt: Er zijn enkele schroefaccessoires op het product gemonteerd die eerst losgemaakt en vervolgens weer aangesloten moeten worden.

# PARTS LIST









<p>A</p>  <p>1PCS</p>	<p>B</p>  <p>1PCS</p>	<p>C</p>  <p>1PCS</p>	<p>D</p>  <p>1PCS</p>	<p>E</p>  <p>1PCS</p>
<p>F</p>  <p>1PCS</p>	<p>G</p>  <p>1PCS</p>	<p>H</p>  <p>1PCS</p>	<p>I</p>  <p>6PCS</p>	<p>J</p>  <p>2PCS</p>
<p>K</p>  <p>5 PCS</p>	<p>L</p>  <p>1PCS</p>	<p>M</p>  <p>1PCS</p>	<p>N</p>  <p>2PCS</p>	<p>O</p>  <p>1 PCS</p>
<p>P</p>  <p>1 PCS</p>	<p>Q</p>  <p>1PCS</p>	<p>R</p>  <p>1 PCS</p>	<p>S</p>  <p>2 PCS</p>	<p>T</p>  <p>2 PCS</p>
<p>U</p>  <p>1PCS</p>	<p>V</p>  <p>2PCS</p>	<p>W</p>  <p>2 PCS</p>	<p>X1</p>  <p>1 PCS</p>	<p>X2</p>  <p>1 PCS</p>
<p>Y1</p>  <p>1 PCS</p>	<p>Y2</p>  <p>1 PCS</p>	<p>Y3</p>  <p>3 PCS</p>	<p>Y4</p>  <p>1 PCS</p>	<p>Z</p>  <p>1 PCS</p>

# HARDWARE LIST

<p>1. BOLT (M10×135)</p>  <p style="text-align: center;">1 PCS</p>	<p>2. BOLT (M10×100)</p>  <p style="text-align: center;">1 PCS</p>	<p>3. BOLT (M10×80)</p>  <p style="text-align: center;">4 PCS</p>	<p>4. BOLT (M10×70)</p>  <p style="text-align: center;">10 PCS</p>	<p>5. BOLT (M10×50)</p>  <p style="text-align: center;">3 PCS</p>
<p>6. BOLT (M10×20)</p>  <p style="text-align: center;">8 PCS</p>	<p>7. Spacer Sleeve (10)</p>  <p style="text-align: center;">4 PCS</p>	<p>8. Carriage BOLT (M10×75)</p>  <p style="text-align: center;">8 PCS</p>	<p>9. BOLT (M8×16)</p>  <p style="text-align: center;">2 PCS</p>	<p>10. Washer (M10)</p>  <p style="text-align: center;">52 PCS</p>
<p>11. Big Washer (M10)</p>  <p style="text-align: center;">2 PCS</p>	<p>12. Locknut (M10)</p>  <p style="text-align: center;">27 PCS</p>			







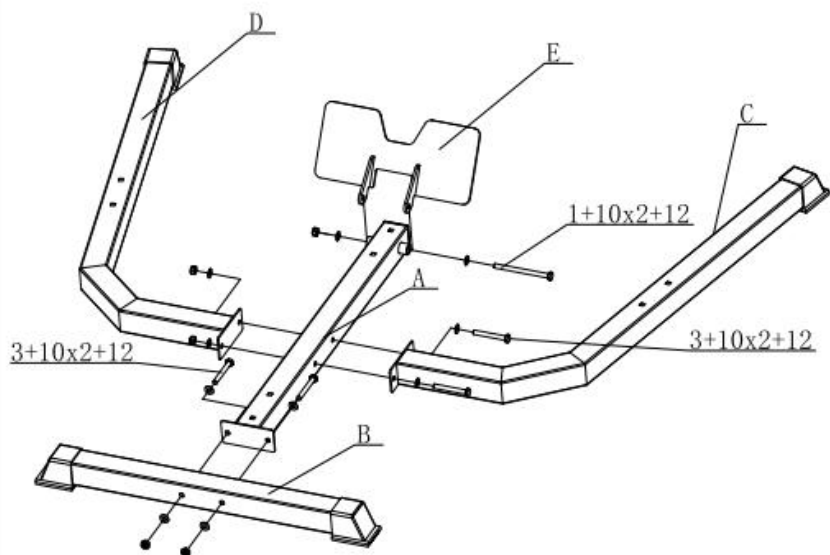

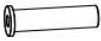

# MONTAGE-INSTRUCTIES

## STEP 1:

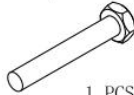
<p>A</p>  <p>1PCS</p>	<p>B</p>  <p>1PCS</p>	<p>C</p>  <p>1PCS</p>	<p>D</p>  <p>1PCS</p>	<p>E</p>  <p>4PCS</p>
<p>1. BOLT (M10 × 135)</p>  <p>1 PCS</p>	<p>3. BOLT (M10 × 80)</p>  <p>4 PCS</p>	<p>10. Washer (M10)</p>  <p>10 PCS</p>	<p>12. Locknut (M10)</p>  <p>5 PCS</p>	







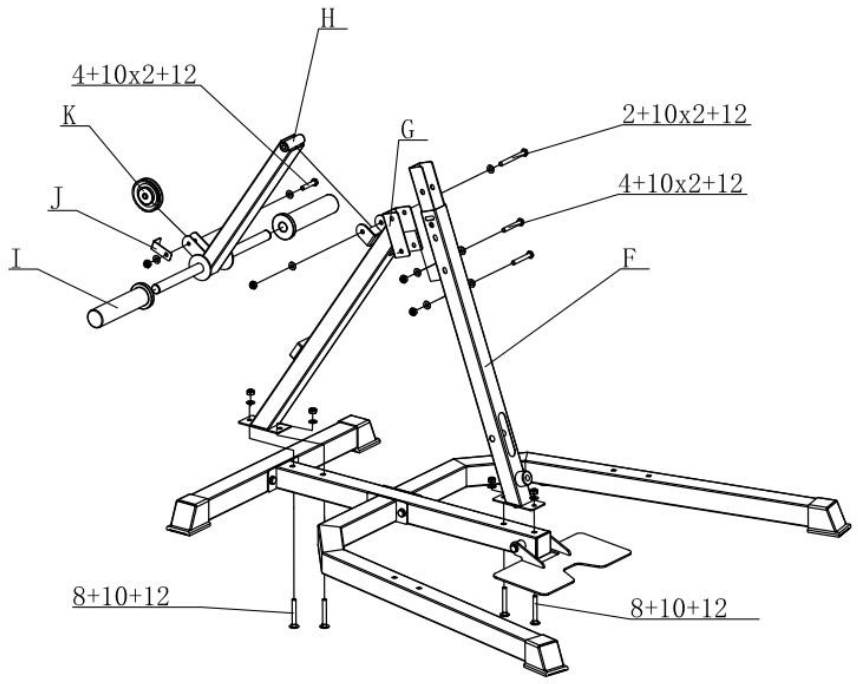



# STEP2:

<p>F</p>  <p>1PCS</p>	<p>G</p>  <p>1PCS</p>	<p>H</p>  <p>1PCS</p>	<p>I</p>  <p>2PCS</p>	<p>J</p>  <p>1PCS</p>
<p>K</p>  <p>1 PCS</p>	<p>2. BOLT (M10×100)</p>  <p>1 PCS</p>	<p>4. BOLT (M10×70)</p>  <p>2 PCS</p>	<p>5. BOLT (M10×50)</p>  <p>1 PCS</p>	<p>8. Carriage BOLT (M10×75)</p>  <p>4 PCS</p>
<p>10. Washer (M10)</p>  <p>12 PCS</p>	<p>12. Locknut (M10)</p>  <p>8 PCS</p>			







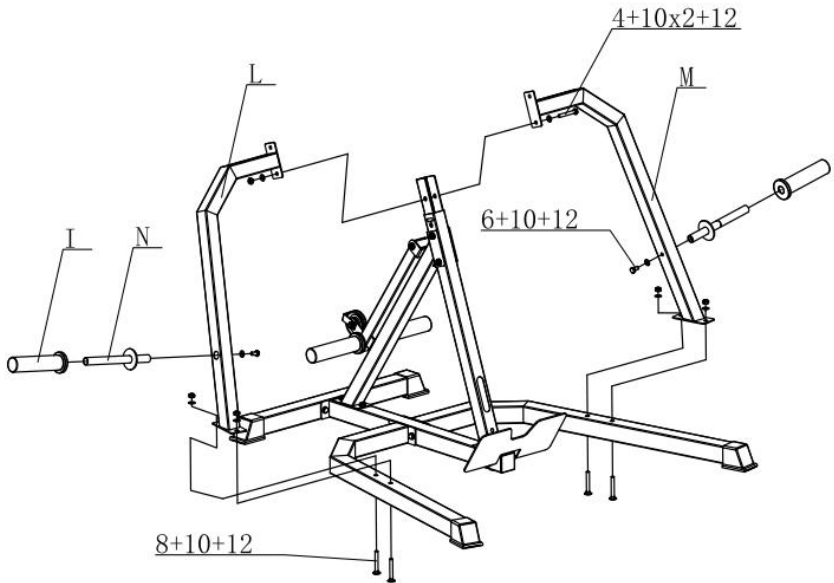



# STEP3:

<p>I</p>  <p>2PCS</p>	<p>L</p>  <p>1PCS</p>	<p>M</p>  <p>1PCS</p>	<p>N</p>  <p>2PCS</p>	<p>4. BOLT (M10×70)</p>  <p>1 PCS</p>
<p>6. BOLT (M10×20)</p>  <p>2 PCS</p>	<p>8. Carriage BOLT (M10×75)</p>  <p>4 PCS</p>	<p>10. Washer (M10)</p>  <p>8 PCS</p>	<p>12. Locknut (M10)</p>  <p>5 PCS</p>	







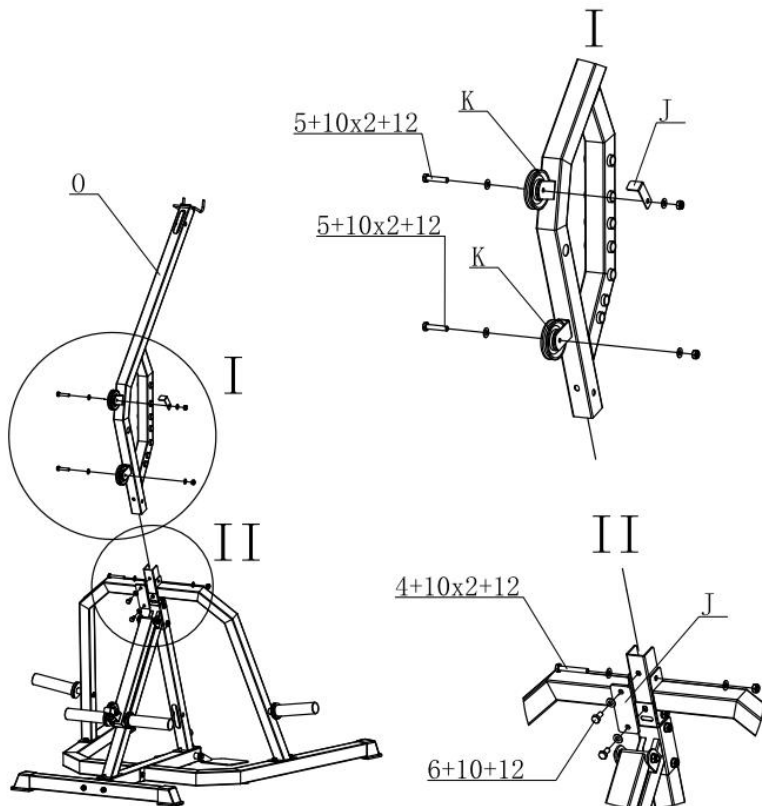









# STEP4:

<p>K</p>  <p>2PCS</p>	<p>J</p>  <p>1PCS</p>	<p>O</p>  <p>1 PCS</p>	<p>P</p>  <p>1 PCS</p>	<p>4. BOLT (M10×70)</p>  <p>1 PCS</p>
<p>5. BOLT (M10×50)</p>  <p>2 PCS</p>	<p>6. BOLT (M10×20)</p>  <p>2 PCS</p>	<p>10. Washer (M10)</p>  <p>8 PCS</p>	<p>12. Locknut (M10)</p>  <p>3 PCS</p>	







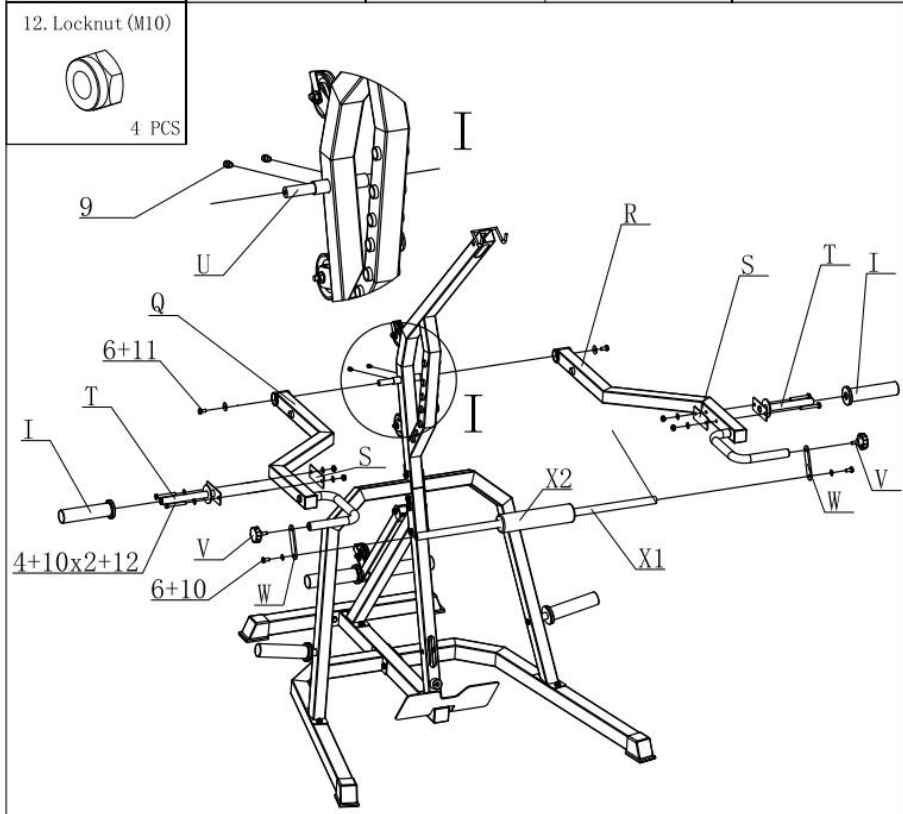





# STEP5:

<p>I</p>  <p>2PCS</p>	<p>Q</p>  <p>1PCS</p>	<p>R</p>  <p>1 PCS</p>	<p>S</p>  <p>2 PCS</p>	<p>T</p>  <p>2 PCS</p>
<p>U</p>  <p>1PCS</p>	<p>V</p>  <p>2PCS</p>	<p>W</p>  <p>2 PCS</p>	<p>X1</p>  <p>1 PCS</p>	<p>X2</p>  <p>1 PCS</p>
<p>4. BOLT (M10×70)</p>  <p>4 PCS</p>	<p>6. BOLT (M10×20)</p>  <p>4 PCS</p>	<p>9. BOLT (M8×16)</p>  <p>2 PCS</p>	<p>10. Washer (M10)</p>  <p>10 PCS</p>	<p>11. Big Washer (M10)</p>  <p>2 PCS</p>



# STEP6:

<p>K</p>  <p>2PCS</p>	<p>Y1</p>  <p>1 PCS</p>	<p>Y2</p>  <p>1 PCS</p>	<p>Y3</p>  <p>3 PCS</p>	<p>Y4</p>  <p>2 PCS</p>
<p>Z</p>  <p>1 PCS</p>	<p>4. BOLT (M10×70)</p>  <p>2 PCS</p>	<p>7. Spacer Sleeve (10)</p>  <p>4 PCS</p>	<p>10. Washer (M10)</p>  <p>4 PCS</p>	<p>12. Locknut (M10)</p>  <p>2 PCS</p>

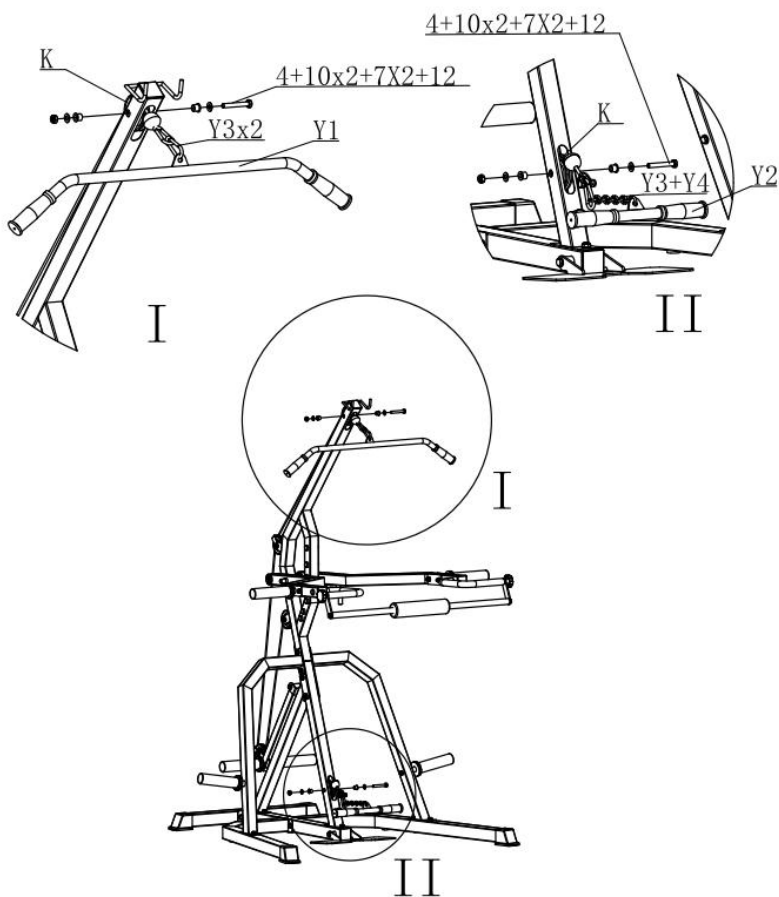

## RICHTLIJNEN VOOR ONDERHOUD EN CONDITIONERING

1. Reiniging en onderhoud: Veeg de squat af met een schone, zachte, vochtige doek. Stel het plastic onderdeel niet bloot aan bijtende oplosmiddelen. Veeg eventuele zweetvlekken na elk gebruik weg. Zorg ervoor dat er niet te veel vocht in contact komt met het scherm van het elektronische horloge, aangezien dit storingen in het circuit kan veroorzaken. Vermijd direct zonlicht tijdens squats, met name op de schermen van elektronische horloges, om schade aan het product te voorkomen. Controleer wekelijks op losse schroeven, moeren en pedalen.
2. Opbergen: Bewaar de squat machine op een droge en schone plaats, buiten bereik van kinderen en huisdieren.
3. **Let op: Niet langer dan 15 minuten achter elkaar gebruiken .**

## VEILIG GEBRUIK VEREIST KENNIS

Hartelijk dank voor uw aankoop van onze producten. Het juiste gebruik van dit apparaat is de garantie voor uw veiligheid en gezondheid. Het is erg belangrijk om de handleiding zorgvuldig te lezen voordat u dit apparaat gebruikt! Alleen wanneer dit apparaat correct is geïnstalleerd, onderhouden en gebruikt, kunt u veilig en effectief trainen.

1. Deze apparatuur is alleen geschikt voor gebruik binnenshuis, thuisgebruik. De maximale gebruikersgewicht en belasting is 120 kg.
2. Dit apparaat behoort tot de HC-klasse en is niet geschikt voor medisch gebruik.
3. Voordat u met de montage begint, is het noodzakelijk om de lijst met onderdelen volledig te begrijpen die voor dit apparaat zijn meegeleverd en installeer het volledig volgens de gebruiksaanwijzing.
4. Voor de installatie is het nodig dat u de juiste gereedschappen gebruikt . Indien nodig, vraag dan de tweede persoon om u te helpen samen stallen .

5. De fitnessapparatuur moet op een vlakke, antislip ondergrond worden geplaatst. Als de apparatuur in een natte ruimte wordt geplaatst, kan corrosie op de lange termijn het gebruik van de apparatuur beïnvloeden.
  6. Controleer voor gebruik of de schroefonderdelen goed vastzitten en zorg ervoor dat er rondom het apparaat een afstand van 0,6 meter is en dat er geen opvallende, verstelbare onderdelen aanwezig zijn.
  7. Controleer regelmatig of de verschillende verbindingsonderdelen van de apparatuur goed vastzitten en of de staat normaal is, om het veiligheidsniveau van de apparatuur te garanderen.
  8. Gebruik geen bijtende reinigingsmiddelen tijdens het onderhoud en de reiniging, om te voorkomen dat er vloeistof via de staart of de opening in de apparatuur komt.
  9. Dit apparaat is bedoeld voor gebruik door volwassenen. Kinderen en huisdieren dienen uit de buurt van dit apparaat te blijven. Het apparaat mag alleen onder begeleiding van volwassenen worden bediend.
  10. Deze apparatuur mag slechts door één persoon tegelijk worden gebruikt. Wijs de mensen in uw omgeving op de mogelijke gevaren, zoals het gevaar van bewegende onderdelen tijdens het sporten.
  11. Draag goed passende kleding tijdens het sporten om te voorkomen dat losse kleding over de apparatuur struikelt of de bewegingsvrijheid beperkt.
  12. Sport niet voor of na de maaltijd.
  13. Let op de oefenmethoden in de instructies.
  14. Raadpleeg uw huisarts voordat u gaat sporten. Hij/zij kan u vertellen welke soort sport en welke belasting het beste bij u passen. Verkeerde sport kan uw gezondheid schaden en overmatige training kan leiden tot ernstig letsel of de dood. Als u zich duizelig voelt, stop dan onmiddellijk met trainen.
- 1 5 , bewaar deze handleiding en installatiehulpmiddelen.
- 1 6 , Mocht u vragen hebben of onze hulp nodig hebben, neem dan contact op met onze aftersales-serviceafdeling.

## **Belangrijk advies**

1. Volg de installatie-instructies en gebruik alleen de onderdelen die geschikt zijn voor dit apparaat.
2. Sportartikelen beschouwen wij in principe niet als speelgoed en mogen alleen worden gebruikt door personen die over de nodige kennis beschikken of begeleiding hebben gehad.
3. Als u last krijgt van duizeligheid, misselijkheid, pijn op de borst of andere abnormale symptomen, stop dan onmiddellijk met sporten en raadpleeg uw arts.
4. Kinderen en gehandicapten mogen dit apparaat alleen gebruiken onder begeleiding van een ervaren gebruiker.
5. Houd er rekening mee dat u en anderen geen enkel lichaamsdeel in het sportgebied mogen steken.
6. Bij de onderdelen van de apparatuur die kunnen worden aangepast, moet u speciaal letten op de gemarkeerde maximale eindpositie.
7. Voer een regelmatige inspectie uit op slijtage en losse onderdelen om te garanderen dat de apparatuur in een goede staat verkeert .

## **Montage-instructie**

1. Het product moet zorgvuldig door volwassenen worden geïnstalleerd, in geval van onzekerheid , Vraag om technische ervaring om hulp.
2. Pak alle verpakkingsmaterialen uit, plaats de verschillende onderdelen, maak de montage duidelijker en gemakkelijker te begrijpen, gebruik de pad om het installatieoppervlak te beschermen en vermijd vuil of krassen.
3. En dan volgens de stuklijst , om te controleren of de onderdelen compleet zijn, pas na de installatie kunnen verpakkingsmaterialen worden weggegooid.
4. Lees de installatie-instructies zorgvuldig door en zorg dat u het bijbehorende schema begrijpt voordat u met de montage begint.
5. Houd er rekening mee dat er bij het gebruik van gereedschap en handmatige bediening risico op letsel kan bestaan. Wees daarom voorzichtig bij het installeren van het product.

6. Nadat u het product volgens de instructies heeft gemonteerd, controleert u zorgvuldig of de schroeven, moeren en knoppen correct zijn geïnstalleerd en vastgedraaid.

7. Plaats het gereedschap na de installatie niet willekeurig.

8. Het is aan te raden om een beschermmat (niet meegeleverd bij het product) onder het product te leggen om de vloer te beschermen, omdat het rubber van het product onvermijdelijk sporen achterlaat.

## **Bewegingsspecificatie**

1. Wist je dat matige duurtraining (bijvoorbeeld ongeveer 30 minuten, 2 keer per week) je gezondheid aanzienlijk kan verbeteren? Je bloeddruk, cholesterol, bloedsuikerspiegel, initiatief en zelfs je humeur kunnen allemaal aanzienlijk verbeteren met een kleine hoeveelheid beweging. Je kunt je lichaamsvetpercentage verlagen door kleine veranderingen aan te brengen in je lichaamsvorm en je voedingsinname hierop aan te passen.

2. Trainen moet altijd beginnen met een warming-up. Hoe zwaarder de training, hoe belangrijker het is om op te warmen. Een warming-up bereidt het lichaam voor op de belasting, stimuleert het cardiovasculaire systeem en beschermt de banden.

Pezen en gewrichten worden beschermd tegen blessures. Het helpt ook het risico op krampen en spierblessures te verminderen .



**Fabrikant:** Shanghaimuxinmuyeyouxiangongsi

**Adres:** Shuangchenglu 803nong11hao1602A-1609shi, baoshanqu, shanghai 200000 CN.

**Geïmporteerd naar AUS:** SIHAO PTY LTD. 1 ROKEVA

STREETEASTWOOD

NSW 2122 Australië

**Geïmporteerd naar de VS:** Sanven Technology Ltd. Suite 250, 9166

Anaheim

Plaats, Rancho Cucamonga, CA 91730

<b>UK</b>	<b>REP</b>
-----------	------------

YH CONSULTING LIMITED. C/O YH Consulting  
Limited Office 147, Centurion House, London  
Road, Staines-upon-Thames, Surrey, TW18 4AX

<b>EC</b>	<b>REP</b>
-----------	------------

E-CrossStu GmbH  
Mainzer Landstr.69,  
60329 Frankfurt am Main.



# **VEVOR**

**Affordable. Reliable. Home Improvement.**

## **HACK SQUAT MASKIN**

**MODELL: HM2901A**

# VEVOR

Affordable. Reliable. Home Improvement.

## HACK SQUAT MACHINE

MODELL: HM2901A

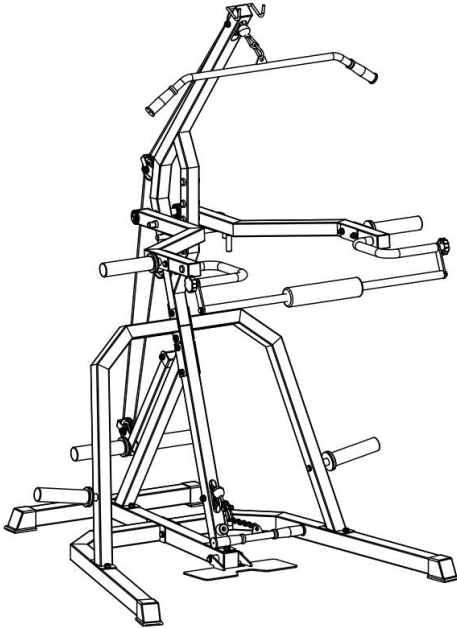

### Installation Instruction



Detta är originalinstruktionerna, vänligen läs alla instruktioner noggrant innan du använder produkten. VEVOR förbehåller sig en tydlig tolkning av vår användarmanual. Produktens utseende ska vara beroende av den produkt du mottagit. Vi ber om ursäkt för att vi inte kommer att informera dig igen om det finns några teknik- eller programuppdateringar för vår produkt.

































Varning – För att minska risken för skador måste användaren läsa instruktionsmanualen noggrant.

## CHECKLISTA FÖR MONTERING









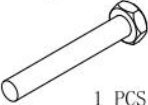
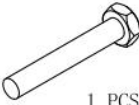

**Se till att alla delar är inkluderade innan monteringen påbörjas.**

Noterat: Vissa skruvtillbehör har installerats på produkten och behöver lossas och sedan anslutas.

# PARTS LIST









<p>A</p>  <p>1PCS</p>	<p>B</p>  <p>1PCS</p>	<p>C</p>  <p>1PCS</p>	<p>D</p>  <p>1PCS</p>	<p>E</p>  <p>1PCS</p>
<p>F</p>  <p>1PCS</p>	<p>G</p>  <p>1PCS</p>	<p>H</p>  <p>1PCS</p>	<p>I</p>  <p>6PCS</p>	<p>J</p>  <p>2PCS</p>
<p>K</p>  <p>5 PCS</p>	<p>L</p>  <p>1PCS</p>	<p>M</p>  <p>1PCS</p>	<p>N</p>  <p>2PCS</p>	<p>O</p>  <p>1 PCS</p>
<p>P</p>  <p>1 PCS</p>	<p>Q</p>  <p>1PCS</p>	<p>R</p>  <p>1 PCS</p>	<p>S</p>  <p>2 PCS</p>	<p>T</p>  <p>2 PCS</p>
<p>U</p>  <p>1PCS</p>	<p>V</p>  <p>2PCS</p>	<p>W</p>  <p>2 PCS</p>	<p>X1</p>  <p>1 PCS</p>	<p>X2</p>  <p>1 PCS</p>
<p>Y1</p>  <p>1 PCS</p>	<p>Y2</p>  <p>1 PCS</p>	<p>Y3</p>  <p>3 PCS</p>	<p>Y4</p>  <p>1 PCS</p>	<p>Z</p>  <p>1 PCS</p>

# HARDWARE LIST

<p>1. BOLT (M10×135)</p>  <p style="text-align: center;">1 PCS</p>	<p>2. BOLT (M10×100)</p>  <p style="text-align: center;">1 PCS</p>	<p>3. BOLT (M10×80)</p>  <p style="text-align: center;">4 PCS</p>	<p>4. BOLT (M10×70)</p>  <p style="text-align: center;">10 PCS</p>	<p>5. BOLT (M10×50)</p>  <p style="text-align: center;">3 PCS</p>
<p>6. BOLT (M10×20)</p>  <p style="text-align: center;">8 PCS</p>	<p>7. Spacer Sleeve (10)</p>  <p style="text-align: center;">4 PCS</p>	<p>8. Carriage BOLT (M10×75)</p>  <p style="text-align: center;">8 PCS</p>	<p>9. BOLT (M8×16)</p>  <p style="text-align: center;">2 PCS</p>	<p>10. Washer (M10)</p>  <p style="text-align: center;">52 PCS</p>
<p>11. Big Washer (M10)</p>  <p style="text-align: center;">2 PCS</p>	<p>12. Locknut (M10)</p>  <p style="text-align: center;">27 PCS</p>			







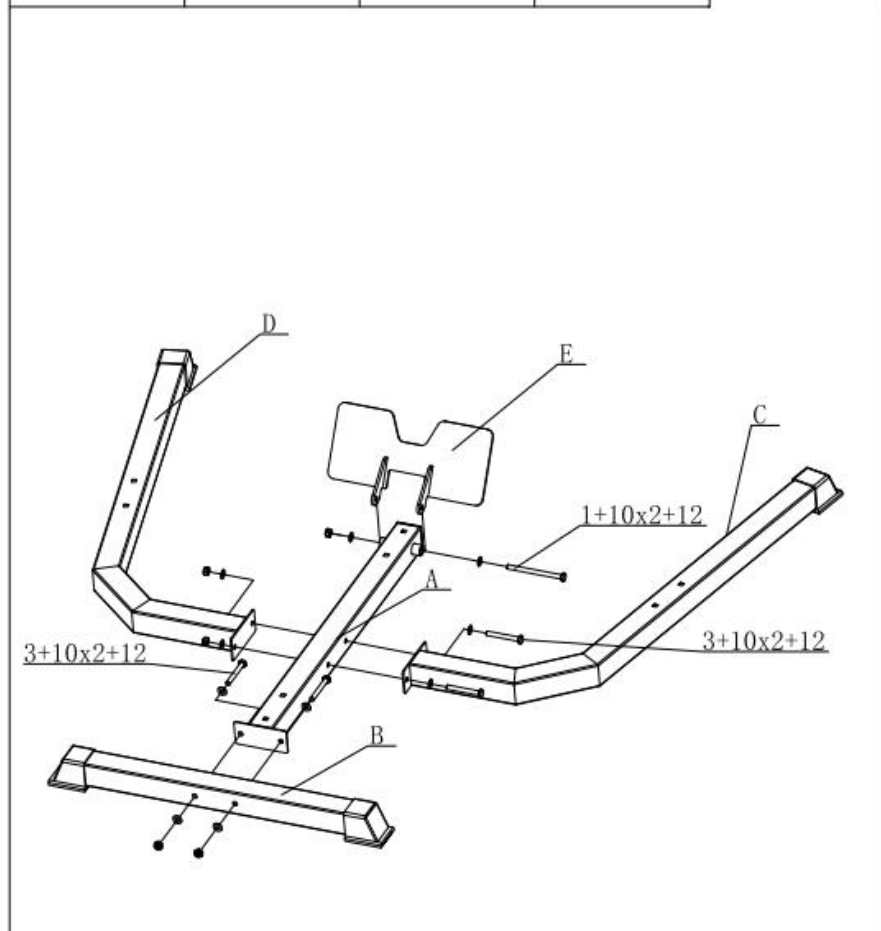

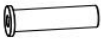

# MONTERINGSANVISNINGAR

## STEP 1:

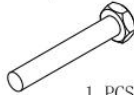
<b>A</b>  1PCS	<b>B</b>  1PCS	<b>C</b>  1PCS	<b>D</b>  1PCS	<b>E</b>  4PCS
1. BOLT (M10 × 135)  1 PCS	3. BOLT (M10 × 80)  4 PCS	10. Washer (M10)  10 PCS	12. Locknut (M10)  5 PCS	







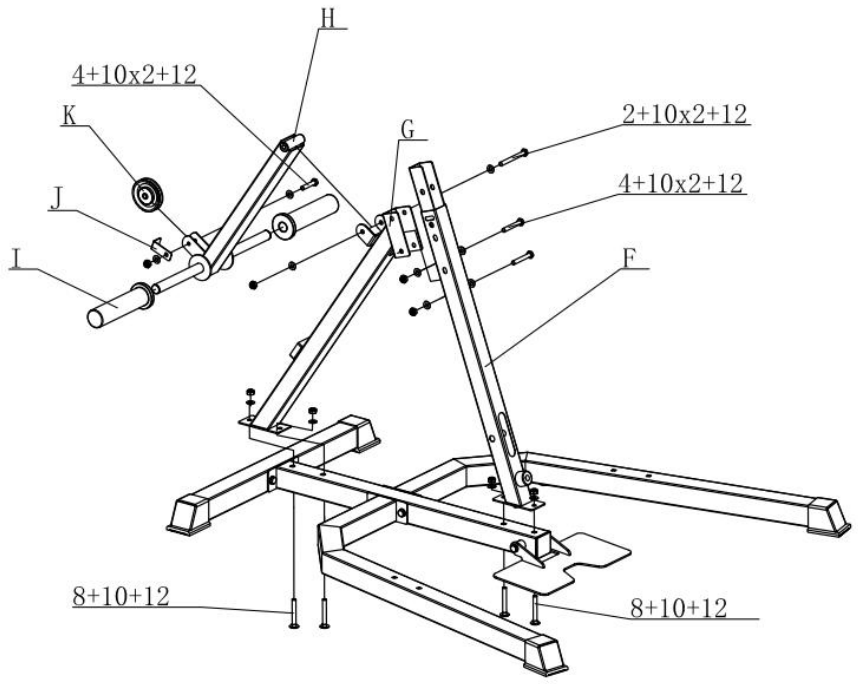



# STEP2:

<p>F</p>  <p>1PCS</p>	<p>G</p>  <p>1PCS</p>	<p>H</p>  <p>1PCS</p>	<p>I</p>  <p>2PCS</p>	<p>J</p>  <p>1PCS</p>
<p>K</p>  <p>1 PCS</p>	<p>2. BOLT (M10×100)</p>  <p>1 PCS</p>	<p>4. BOLT (M10×70)</p>  <p>2 PCS</p>	<p>5. BOLT (M10×50)</p>  <p>1 PCS</p>	<p>8. Carriage BOLT (M10×75)</p>  <p>4 PCS</p>
<p>10. Washer (M10)</p>  <p>12 PCS</p>	<p>12. Locknut (M10)</p>  <p>8 PCS</p>			







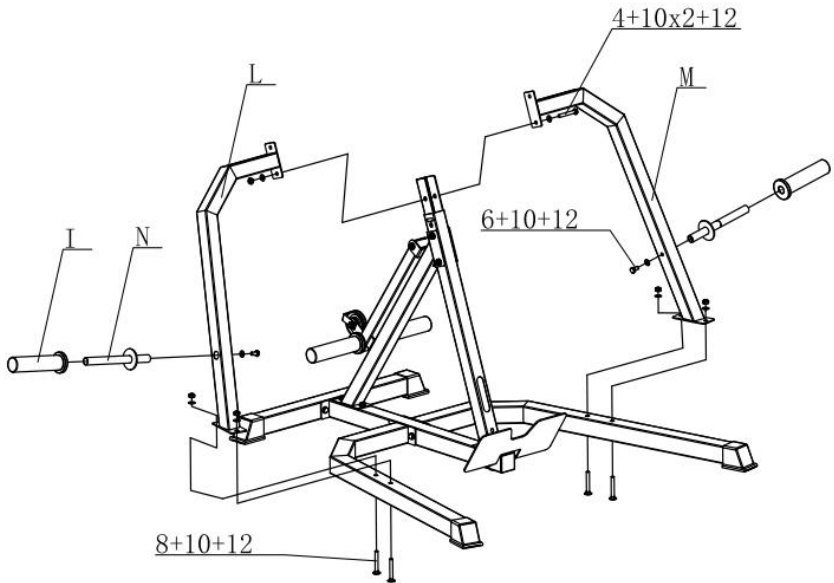



# STEP3:

<p>I</p>  <p>2PCS</p>	<p>L</p>  <p>1PCS</p>	<p>M</p>  <p>1PCS</p>	<p>N</p>  <p>2PCS</p>	<p>4. BOLT (M10×70)</p>  <p>1 PCS</p>
<p>6. BOLT (M10×20)</p>  <p>2 PCS</p>	<p>8. Carriage BOLT (M10×75)</p>  <p>4 PCS</p>	<p>10. Washer (M10)</p>  <p>8 PCS</p>	<p>12. Locknut (M10)</p>  <p>5 PCS</p>	







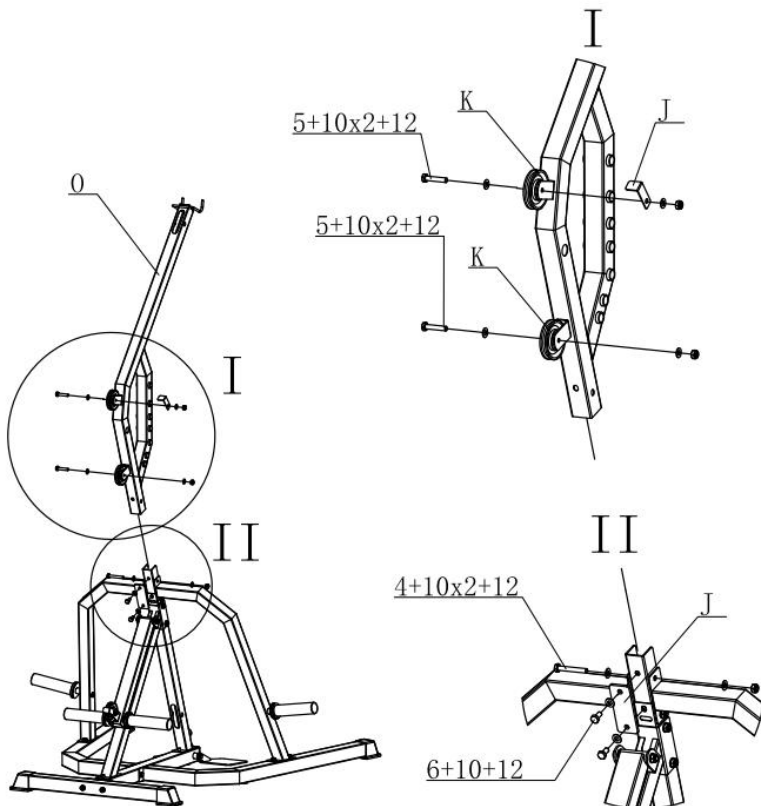









# STEP4:

<p>K</p>  <p>2PCS</p>	<p>J</p>  <p>1PCS</p>	<p>O</p>  <p>1 PCS</p>	<p>P</p>  <p>1 PCS</p>	<p>4. BOLT (M10×70)</p>  <p>1 PCS</p>
<p>5. BOLT (M10×50)</p>  <p>2 PCS</p>	<p>6. BOLT (M10×20)</p>  <p>2 PCS</p>	<p>10. Washer (M10)</p>  <p>8 PCS</p>	<p>12. Locknut (M10)</p>  <p>3 PCS</p>	



# STEP5:

<p>I</p>  <p>2PCS</p>	<p>Q</p>  <p>1PCS</p>	<p>R</p>  <p>1 PCS</p>	<p>S</p>  <p>2 PCS</p>	<p>T</p>  <p>2 PCS</p>
<p>U</p>  <p>1PCS</p>	<p>V</p>  <p>2PCS</p>	<p>W</p>  <p>2 PCS</p>	<p>X1</p>  <p>1 PCS</p>	<p>X2</p>  <p>1 PCS</p>
<p>4. BOLT (M10×70)</p>  <p>4 PCS</p>	<p>6. BOLT (M10×20)</p>  <p>4 PCS</p>	<p>9. BOLT (M8×16)</p>  <p>2 PCS</p>	<p>10. Washer (M10)</p>  <p>10 PCS</p>	<p>11. Big Washer (M10)</p>  <p>2 PCS</p>







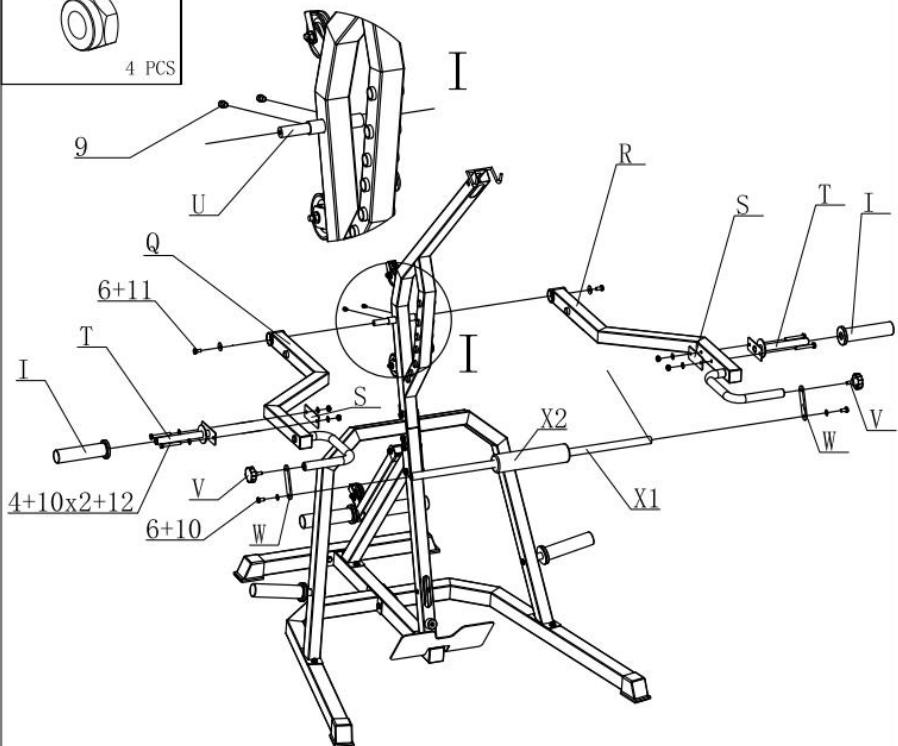



12. Locknut (M10)



4 PCS



# STEP6:

<p>K</p>  <p>2PCS</p>	<p>Y1</p>  <p>1 PCS</p>	<p>Y2</p>  <p>1 PCS</p>	<p>Y3</p>  <p>3 PCS</p>	<p>Y4</p>  <p>2 PCS</p>
<p>Z</p>  <p>1 PCS</p>	<p>4. BOLT (M10×70)</p>  <p>2 PCS</p>	<p>7. Spacer Sleeve (10)</p>  <p>4 PCS</p>	<p>10. Washer (M10)</p>  <p>4 PCS</p>	<p>12. Locknut (M10)</p>  <p>2 PCS</p>

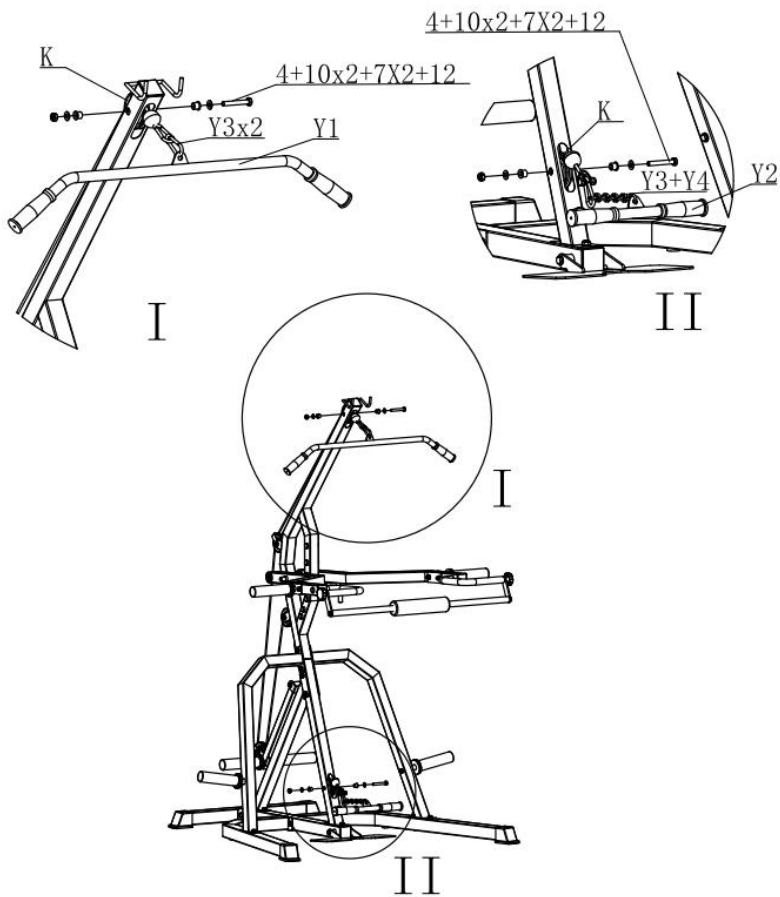

## RIKTLINJER FÖR UNDERHÅLL OCH KONDITIONERING

1. Rengöring och underhåll: Torka av squaten med en ren, mjuk och fuktig trasa. Utsätt inte plastdelen för frätande lösningsmedel. Torka bort eventuella svettfläckar som kan finnas kvar på squaten efter varje användning.

Var försiktig så att inte för mycket fukt kommer i kontakt med den elektroniska klockskärmen, eftersom det kan orsaka funktionsfel. Undvik direkt solljus vid knäböj, särskilt vid elektroniska klockskärmar, för att undvika skador på produkten. Kontrollera varje vecka för lösa skruvar, muttrar och pedaler.

2. Förvaring: Förvara knäböjsmaskinen i en torr och ren miljö utom räckhåll för barn och husdjur.

**3. Obs: Använd inte i mer än 15 minuter åt gången .**

## SÄKER ANVÄNDNING BEHÖVER VETA

Tack för att du köpt våra produkter. Korrekt användning av denna apparat är en garanti för din säkerhet och hälsa. Det är mycket viktigt att läsa bruksanvisningen noggrant innan du använder apparaten! Endast när utrustningen är korrekt installerad, underhållen och använd kan träningen vara säker och effektiv.

1. Denna utrustning är endast lämplig för inomhusbruk, hemmabruk. Maximalt Användarvikt och belastning är 120 kg.

2. Denna apparat tillhör HC -kvaliteten och är inte lämplig för medicinskt bruk.

3, Innan montering är det nödvändigt att förstå listan över delar fullt ut som medföljer denna utrustning, och installera i fullständig enlighet med instruktionsmanualen.

4, Installationen kräver att lämpliga verktyg används . Om det behövs, vänligen be den andra personen att hjälpa dig med stannar tillsammans .

5. Träningsutrustningen måste placeras på en plan, halkfri yta för att kunna användas. Om den placeras i ett vått utrymme kommer utrustningens långsiktiga användning att påverkas av korrosion.
6. Kontrollera att skruvdelarna är låsta före användning och se till att det finns ett fritt avstånd på 0,6 meter runt utrustningen och att det inte finns några framträdande justerbara anordningar.
7. Kontrollera regelbundet att utrustningens olika anslutningsdelar är åtdragna och att de är i normalt skick för att säkerställa utrustningens säkerhetsnivå.
8. Använd inte frätande rengöringsmedel under underhåll och rengöring för att undvika att vätska kommer in i utrustningen genom änden eller springan.
9. Denna enhet används av vuxna, barn och husdjur bör hålla sig borta från enheten och får endast användas under ledning av vuxna.
10. Denna utrustning kan endast användas av en person åt gången. Vänligen påpeka de möjliga farorna för människorna runt omkring dig, såsom faran med rörliga delar under träning.
11. Använd välsittande kläder när du tränar för att förhindra att löst sittande kläder snubblar på utrustningen eller begränsar rörelsefriheten.
12. Träna inte före och efter måltider.
13. Var uppmärksam på övningsmetoderna i instruktionerna.
14. Rådfråga din husläkare innan du börjar träna. Läkaren kommer att tala om för dig vilken typ av träning och träningsbelastning som är lämplig för dig. Fel träning kan skada din hälsa, överdriven träning kan leda till allvarliga skador eller dödsfall. Om du känner dig yr , sluta träna omedelbart.
- 15 , vänligen spara denna manual och installationsverktygen.
- 16 , Om du har några frågor eller behöver vår hjälp, vänligen kontakta vår kundserviceavdelning.

## **Viktiga råd**

1. Följ installationsanvisningarna och använd endast de delar som är konfigurerade med den här enheten.
- 2, I princip betraktar vi inte sportutrustning som leksaker, och den kan endast användas av personer som har relevant kunskap eller har fått vägledning.
3. Om du upplever yrsel, illamående, bröstsmärtor eller andra onormala symtom, sluta träna omedelbart och kontakta din läkare.
- 4, Såsom barn och personer med funktionsnedsättning, bör endast under ledning av en skicklig operatör använda denna utrustning.
- 5, Observera att du eller andra inte får placera någon del av kroppen i idrottsområdet.

Var särskilt uppmärksam på det markerade maxgränsläget i de delar av utrustningen som kan justeras.

- 7, Endast regelbunden inspektion av slitage och lösa delar, för att säkerställa att utrustningen är i högkvalitativt skick .

## **Monteringsanvisning**

1. Produkten måste installeras noggrant av vuxna. Vid osäkerhet , be gärna om teknisk erfarenhet för hjälp.
2. Packa upp allt förpackningsmaterial, placera de olika delarna, gör det tydligare och lättare att förstå monteringen, använd dynan för att skydda installationsytan och undvik smuts eller repor.
3. Kontrollera sedan, enligt reservdelslistan , om delarna är kompletta. Först efter installationen kan förpackningsmaterialen kasseras.
- 4, Läs noggrant igenom installationsanvisningarna och förstå motsvarande schematiska diagram innan monteringen påbörjas.
- 5, Observera att vid användning av verktyg och manuell drift kan det finnas risk för skador under användning, så var försiktig vid installation av produkten.
6. Efter att produkten har monterats enligt anvisningarna, kontrollera noggrant att skruvar, muttrar och vred är korrekt monterade och åtdragna.

7, Placera inte verktyget slumpmässigt efter installationen.

8. Det rekommenderas att du placerar en skyddande matta (medföljer inte produkten) under produkten för att skydda golvet, eftersom produktens gummi oundvikligen lämnar spår.

## **Rörelsespecifikation**

1. Visste du att måttlig uthållighetsträning (t.ex. cirka 30 minuter, 2 gånger i veckan) kan förbättra din hälsa avsevärt? Ditt blodtryck, kolesterol, blodsocker, initiativförmåga och till och med ditt humör kan alla förbättras avsevärt med en liten mängd träning. Du kan minska din kroppsfettprocent genom att göra blygsamma förändringar i din kroppsform och anpassa ditt näringsintag därefter.

2. Träning bör alltid börja med en uppvärmning. Ju svårare träningspasset är, desto viktigare är det att värma upp. Uppvärmningen förbereder kroppen för belastningen, stimulerar hjärt-kärlsystemet och skyddar ligamenten.

senor och leder från skador. Det hjälper också till att minska risken för kramper och muskelskador .



**Tillverkare:** Shanghaimuxinmuyeyouxiangongsi

**Adress:** Shuangchenglu 803nong11hao1602A-1609shi, baoshanqu, Shanghai 200 000 kanadensiska republiken.

**Importerad till Australien:** SIHAO PTY LTD. 1 ROKEVA

STREETEASTWOOD

NSW 2122 Australien

**Importerad till USA:** Sanven Technology Ltd. Suite 250, 9166 Anaheim Plats, Rancho Cucamonga, Kalifornien 91730

<b>UK</b>	<b>REP</b>
-----------	------------

YH CONSULTING LIMITED. C/O YH Consulting Limited Office 147, Centurion House, London Road, Staines-upon-Thames, Surrey, TW18 4AX

<b>EC</b>	<b>REP</b>
-----------	------------

E-CrossStu GmbH  
Mainzer Landstr.69,  
60329 Frankfurt am Main.

