

VEVOR

Affordable. Reliable. Home Improvement.

Free Standing Stainless Steel Sink

MODEL: SS100-1 ; SS1200-1 ; SS100-2 ; SS100-3 ;
SS1200-3 ; SS1200-4;SS100-4 ; SS1200-5

VEVOR

Affordable. Reliable. Home Improvement.

Free Standing Stainless Steel Sink

MODEL: SS100-1; SS1200-1; SS100-2; SS1200-3;

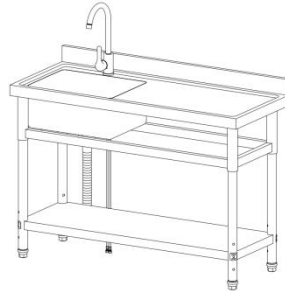
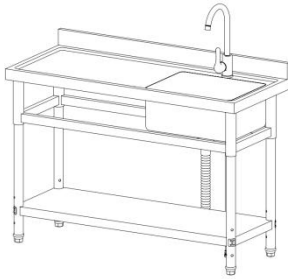

MODEL:SS100-3; SS1200-4; **MODEL:**SS100-4; SS1200-5

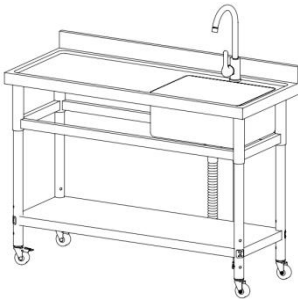

Note:The product picture is for reference,the actual details shall prevail





This is the original instruction, please read all manual instructions carefully before operating. VEVOR reserves a clear interpretation of our user manual. The appearance of the product shall be subject to the product you received. Please forgive us that we won't inform you again if there are any technology or software updates on our product.

Thank you very much for choosing this Product
Please read all of the instructions before using it. The information will help you achieve the best possible results.

Operation safety

Please put this manual in a place easy to check and keep it properly. This instruction manual clearly indicates how to use the equipment safely and correctly, so as to prevent any harm or property loss caused fro you and others.

SAFETY

	Read the instruction manual.		Caution / Warning.
	Note / Remark.		wear gloves



WARNING! Read and understand all instructions before using this Free Standing Stainless Steel Sink. The operator must follow basic precautions to reduce the risk of personal injury and/or damage to the equipment. Keep this manual for safety warnings, precautions, operating or inspection and maintenance instructions.

Please familiarize yourself with the hazard notices found in this manual. A notice is an alert that there is a possibility of property damage, injury or death if certain instructions are not followed.

WARNING! DO NOT let comfort or familiarity with product (gained from repeated use) replace strict adherence to the tool safety rules. If you use this tool unsafely or incorrectly, you can suffer serious personal injury.



Assembly precautions

1. Assemble only according to these instructions. Improper assembly can create hazards.
2. Wear ANSI-approved heavy-duty work gloves during assembly.
3. Keep assembly area clean and well lit.
4. Keep bystanders out of the area during assembly.
5. Do not assemble when tired or when under the influence of alcohol,

drugs or medication.

6. Weight capacity and other product capabilities apply to properly and completely assembled product only.

7. Assemble on a flat, level, hard and smooth surface capable of safely supporting a fully loaded Chest .













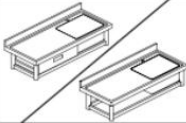





Use precautions







TO PREVENT SERIOUS INJURY AND DEATH FROM TIPPING:

1. DO NOT SIT, STAND OR CLIMB ON THIS ITEM.
2. This product is not a toy nor a toy chest. Do not allow children to play with or near this item.
3. Inspect before every use; do not use if parts are loose or damaged.

Part List

NOTE: Some fasteners may have spare parts. Please pay attention during installation.

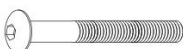
Parts No.	Picture	Qty	Parts No.	Picture	Qty
(A)		1PC	(J)	 transparent	1PC
(B)		1PC	(K)		1PC
(C)		4PCS	(L)		1PC
(D)		2PCS	(M)		1PC
(E)		2PCS	(N)		1PC
<p>Note: Casters D and E are only compatible with models SS100-3 and SS1200-4.</p>			(O)	 White	1PC
(G)		each style 2PCS	(P)	 Dark blue	1PC
(H)		1PC	(Q)	 Black	1PC
(I)		1PC	(R)		1PC

Parts No.	Picture	Qty	Parts No.	Picture	Qty
Ⓢ		1PC	ⓧ		1PC
Ⓣ		4PCS			
Ⓤ		4PCS			
Ⓥ		4PCS			
Ⓦ		4PCS			

Assembly Steps

1

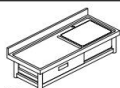

(A) x1pc



(C) x4pcs

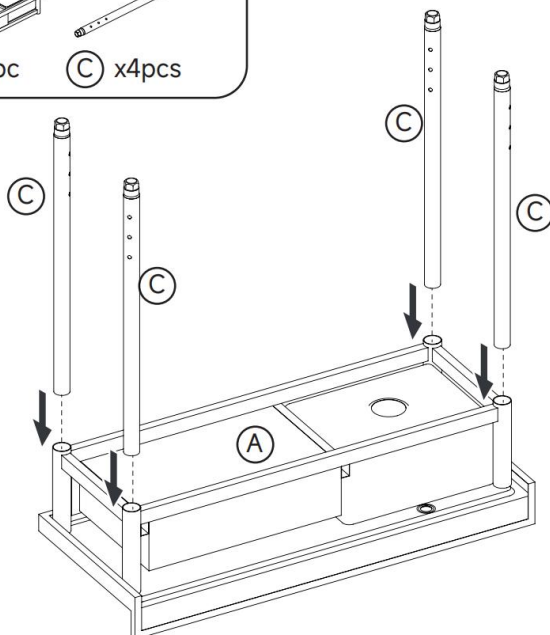

2



(B) x1pc



(T) x4pcs



(U) x4pcs



(V) x4pcs



(W) x4pcs

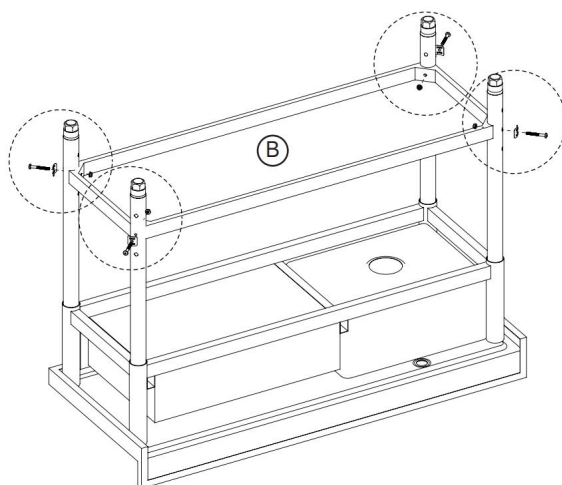
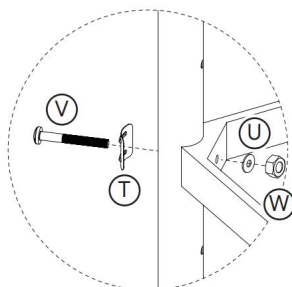

3



(D) x2pcs



(E) x2pcs

OR



(F) x4pcs

Rotate the wheels or adjust the feet as needed

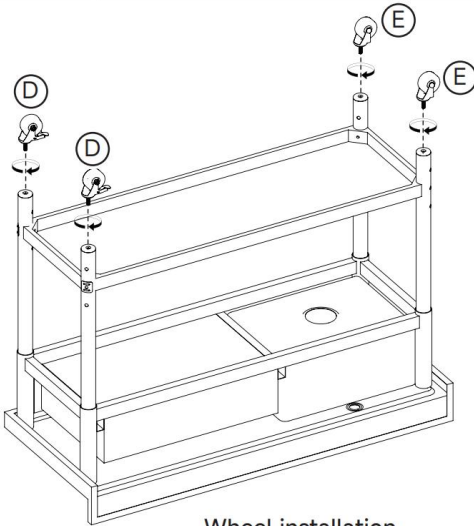

Wheel installation

OR

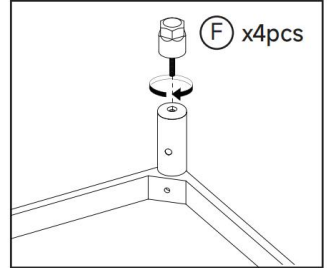

Adjustable foot installation

NOTE :This installation step is only applicable to models SS100-3 and SS1200-4. Other models do not have casters.

4

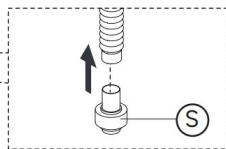
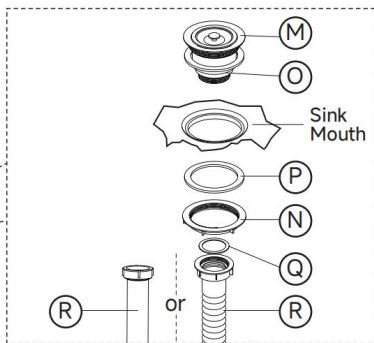
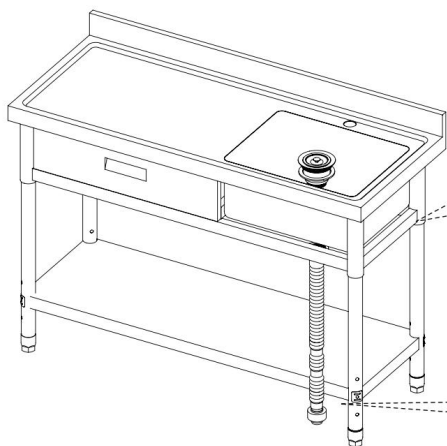
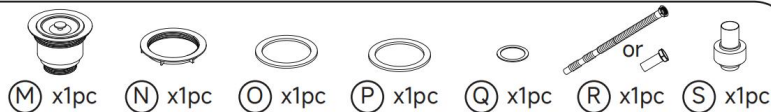

NOTE :The flexible hose R and rigid pipe R of the drainage pipe can be selectively installed according to the user's usage scenario.

.Generally speaking, when installing the flexible hose, it is directly connected to the ground drain of the garden.(Figure A)

.Installing hard pipes is generally suitable for connecting the sewer pipes inside a household.(Figure B)



B



5



G x2pcs



H x1pc



I x1pc



J x1pc



K x1pc



L x1pc

5-1

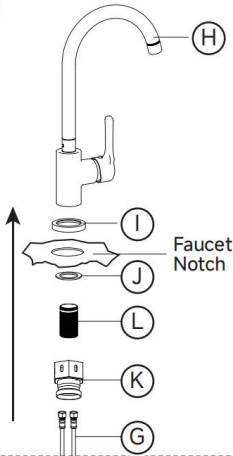

Faucet
Notch

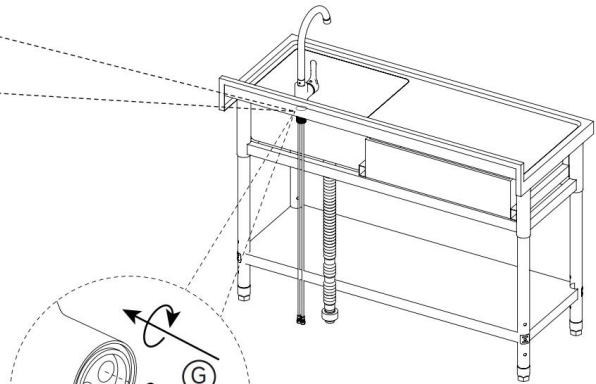

5-2

Align the red pattern tube (G) to the red port.
Align the blue pattern tube (G) to the blue port.

6

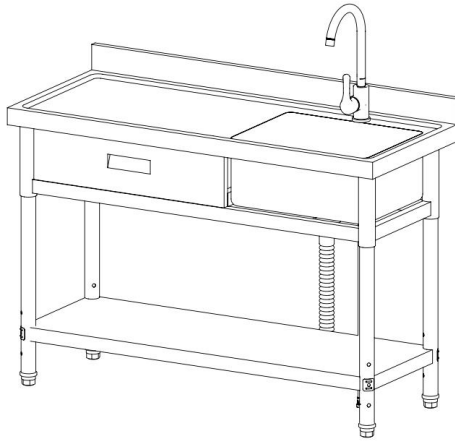

Completed

CARE AND MAINTENANCE

Cleaning:

After use, be sure to dry the water on the draining platform and the sink with a cloth.

At the same time, if there are rust spots or hard-to-treat marks on the surface, please wipe them with the complimentary scouring pad

Notice:

Regularly check if the product screws are loose and tighten them regularly.

Manufacturer: Shanghaimuxinmuyeyouxiangongsi

Address: Shuangchenglu 803nong11hao1602A-1609shi, baoshanqu, shanghai 200000 CN.

Imported to AUS: SIHAO PTY LTD. 1 ROKEVA STREETEASTWOOD NSW 2122 Australia

Imported to USA: Sanven Technology Ltd. Suite 250, 9166 Anaheim Place, Rancho Cucamonga, CA 91730

UK	REP
-----------	------------

YH CONSULTING LIMITED. C/O YH Consulting Limited Office 147, Centurion House, London Road, Staines-upon-Thames, Surrey, TW18 4AX

EC	REP
-----------	------------

E-CrossStu GmbH
Mainzer Landstr.69,
60329 Frankfurt am Main.



VEVOR

Affordable. Reliable. Home Improvement.

Évier sur pied en acier inoxydable

MODÈLE : SS100-1 ; SS1200-1 ; SS100-2 ; SS100-3 ;
SS1200-3;SS1200-4;SS100-4;SS1200-5

VEVOR

Affordable. Reliable. Home Improvement.

Acier inoxydable autoportant
Évier en
acier

MODÈLE : SS100-1; SS1200-1; SS100-2; SS1200-3;



Modèle : SS100-3 ; SS1200-4 ; Modèle : SS100-4 ; SS1200-5



Remarque : l'image du produit est à titre de référence, les détails réels prévalent

Ceci est le mode d'emploi d'origine. Veuillez lire attentivement l'intégralité du manuel avant utilisation. VEVOR se réserve le droit d'interpréter clairement ce manuel d'utilisation. L'apparence du produit dépend du produit que vous avez reçu. Veuillez nous excuser pour les éventuelles mises à jour technologiques ou logicielles.

Merci beaucoup d'avoir choisi ce produit

Veuillez lire toutes les instructions avant de l'utiliser. Les informations vous aideront obtenir les meilleurs résultats possibles.

Sécurité de fonctionnement

Veuillez placer ce manuel dans un endroit facile à consulter et le conserver correctement.

Le manuel d'instructions indique clairement comment utiliser l'équipement en toute sécurité et correctement, afin d'éviter tout dommage ou perte de propriété causé à vous et à d'autres.

SÉCURITÉ

	Lisez le manuel d'instructions.		Attention / Avertissement.
	Note / Remarque.		porter des gants



AVERTISSEMENT ! Veuillez lire attentivement toutes les instructions avant d'utiliser ce produit.

Évier autoportant en acier inoxydable. L'opérateur doit suivre les instructions de base.

précautions pour réduire le risque de blessures corporelles et/ou de dommages à l'environnement équipement. Conservez ce manuel pour les avertissements de sécurité, les précautions, le fonctionnement ou instructions d'inspection et d'entretien.

Veuillez vous familiariser avec les avertissements de danger figurant dans ce manuel. Un avertissement est une alerte indiquant qu'il existe un risque de dommages matériels, de blessures ou de décès si certains les instructions ne sont pas suivies.

ATTENTION ! NE PAS laisser le confort ou la familiarité avec le produit (acquis par (utilisation répétée) remplacent le strict respect des règles de sécurité de l'outil. Si vous

Si vous utilisez cet outil de manière dangereuse ou incorrecte, vous risquez de subir de graves dommages corporels. blessure.



Précautions de montage

1. Assemblez uniquement conformément à ces instructions. Un assemblage incorrect peut créer des dangers.
2. Portez des gants de travail robustes approuvés par l'ANSI pendant l'assemblage.
3. Gardez la zone de montage propre et bien éclairée.
4. Gardez les spectateurs hors de la zone pendant le montage.
5. Ne vous assemblez pas lorsque vous êtes fatigué ou sous l'influence de l'alcool,

drogues ou médicaments.

6. La capacité de poids et les autres capacités du produit s'appliquent correctement et produit entièrement assemblé uniquement.

7. Assembler sur une surface plane, de niveau, dure et lisse capable de soutenir en toute sécurité un coffre entièrement chargé.













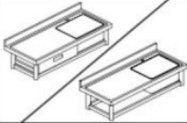





Précautions d'emploi







POUR ÉVITER LES BLESSURES GRAVES ET LA MORT DUE AU BASCULEMENT :

1. NE PAS S'ASSEOIR, SE TENIR DEBOUT OU GRIMPER SUR CET ARTICLE.
2. Ce produit n'est ni un jouet ni un coffre à jouets. Ne laissez pas les enfants jouer avec. avec ou à proximité de cet article.
3. Inspectez avant chaque utilisation ; ne pas utiliser si des pièces sont desserrées ou endommagées.

Liste des pièces

REMARQUE : Certaines fixations peuvent être équipées de pièces de rechange. Veuillez faire attention lors de leur utilisation.
installation.

Parts No.	Picture	Qty	Parts No.	Picture	Qty
(A)		1PC	(J)	 transparent	1PC
(B)		1PC	(K)		1PC
(C)		4PCS	(L)		1PC
(D)		2PCS	(M)		1PC
(E)		2PCS	(N)		1PC
Remarque : les roulettes D et E ne sont que compatible avec les modèles SS100-3 et SS1200-4.			(O)	 White	1PC
(G)		chaque style 2PCS	(P)	 Dark blue	1PC
(H)		1PC	(Q)	 Black	1PC
(I)		1PC	(R)		1PC

Parts No.	Picture	Qty	Parts No.	Picture	Qty
Ⓢ		1PC	Ⓧ		1PC
Ⓣ		4PCS			
Ⓤ		4PCS			
Ⓥ		4PCS			
Ⓦ		4PCS			

Étapes d'assemblage

1



(A) x1pc



(C) x4pcs

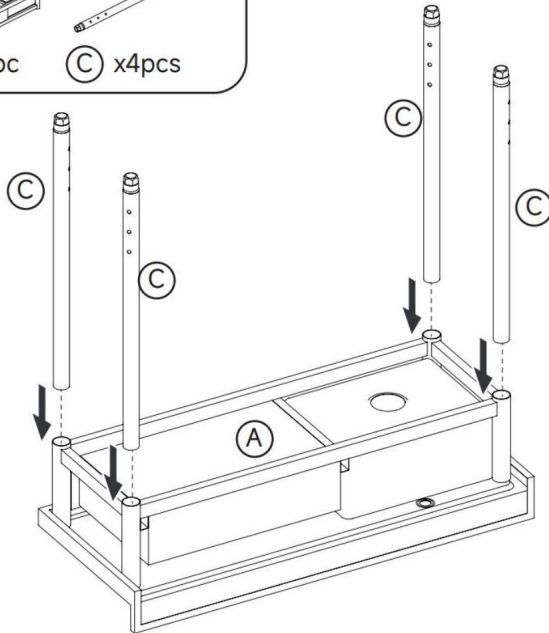

2



(B) x1pc



(T) x4pcs



(U) x4pcs



(V) x4pcs



(W) x4pcs

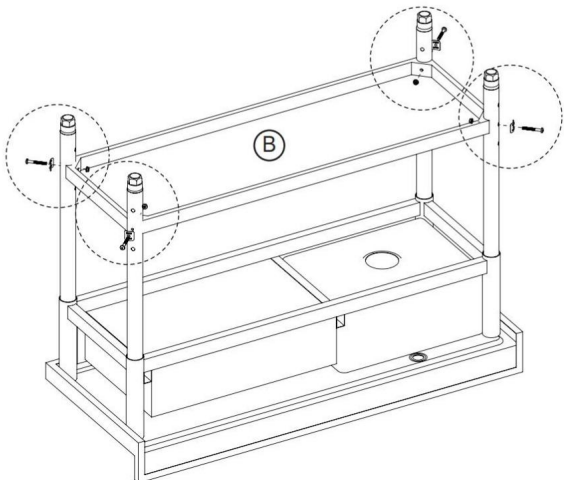
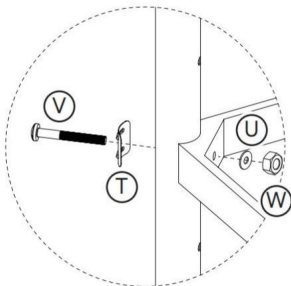

3



(D) x2pcs



(E) x2pcs

OR



(F) x4pcs

Rotate the wheels or adjust the feet as needed

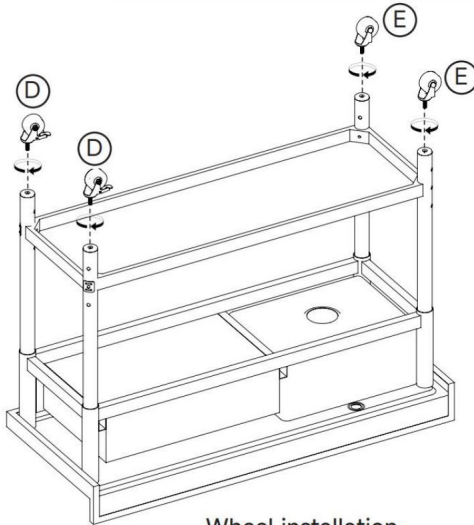

Wheel installation

OR

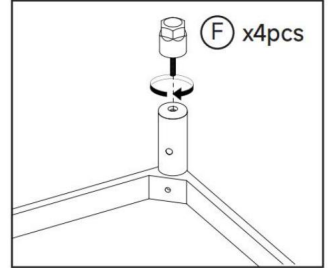

Adjustable foot installation

REMARQUE : Cette étape d'installation s'applique uniquement aux modèles SS100-3 et SS1200-4. Les autres modèles ne sont pas équipés de roulettes.

4

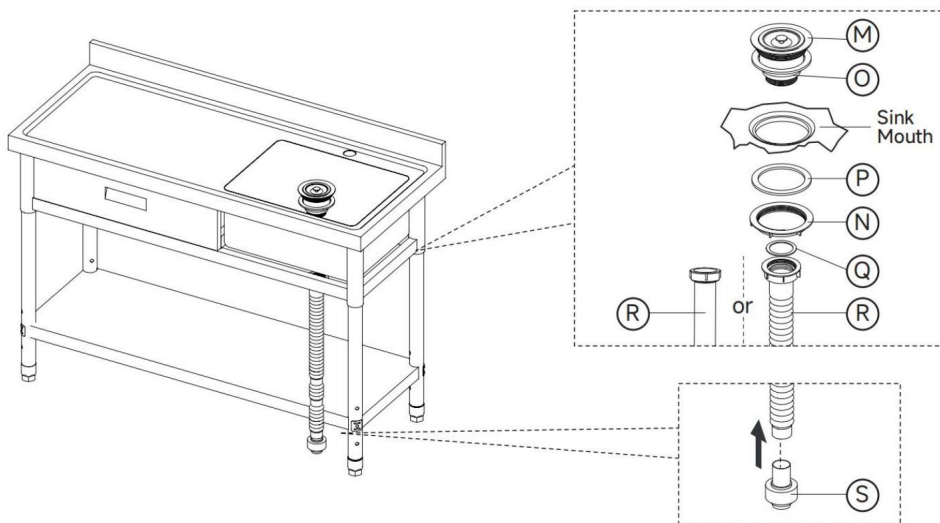
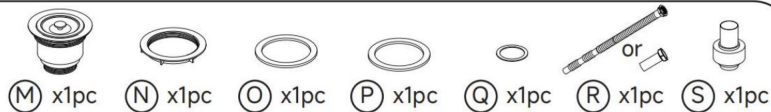

REMARQUE : Le tuyau flexible R et le tuyau rigide R du tuyau de drainage peuvent être installés de manière sélective en fonction du scénario d'utilisation de l'utilisateur.

.En règle générale, lors de l'installation du tuyau flexible, celui-ci est directement connecté au drain de sol du jardin. (Figure A)

L'installation de tuyaux rigides convient généralement au raccordement des canalisations d'égout à l'intérieur d'un foyer. (Figure B)

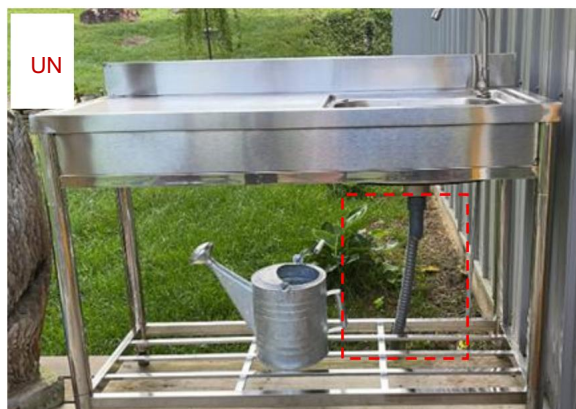

B



5



(G) x2pcs



(H) x1pc



(I) x1pc



(J) x1pc



(K) x1pc



(L) x1pc

5-1

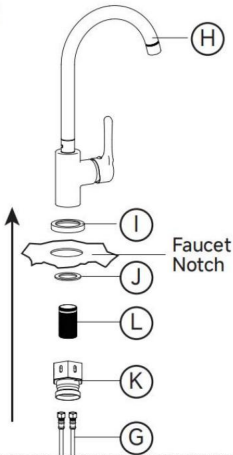

Faucet Notch

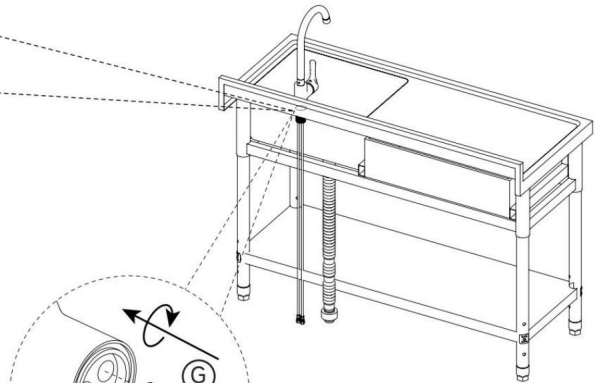

5-2

Align the red pattern tube (G) to the red port.
Align the blue pattern tube (G) to the blue port.

6

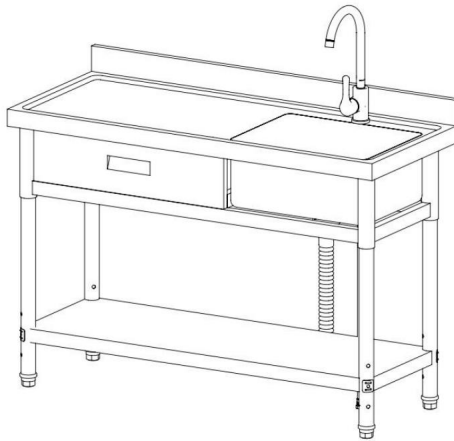

Completed

SOINS ET ENTRETIEN

Nettoyage:

Après utilisation, veillez à sécher l'eau sur la plateforme d'égouttage et l'évier avec un tissu.

En même temps, s'il y a des taches de rouille ou des marques difficiles à traiter sur la surface, veuillez les essuyer avec le tampon à récurer gratuit.

Avis:

Vérifiez régulièrement si les vis du produit sont desserrées et serrez-les régulièrement.

Fabricant : Shanghaimuxinmuyeyouxiangongsi Adresse :
Shuangchenglu 803nong11hao1602A-1609shi, baoshanqu, shanghai 200000 CN.

Importé en Australie : SIHAO PTY LTD. 1 ROKEVA STREET, ASTWOOD NSW 2122,
Australie

Importé aux États-Unis : Sanven Technology Ltd. Suite 250, 9166 Anaheim Place,
Rancho Cucamonga, CA 91730

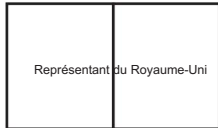

YH CONSULTING LIMITED. A/S YH Consulting Limited,
bureau 147, Centurion House, London Road, Staines-
upon-Thames, Surrey, TW18 4AX

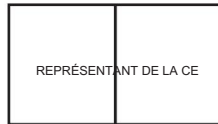

E-CrossStu GmbH
Mainzer Landstr.69,
60329 Francfort-sur-le-Main.



VEVOR

Affordable. Reliable. Home Improvement.

Freistehendes Spülbecken aus Edelstahl

MODELL: SS100-1; SS1200-1; SS100-2; SS100-3;
SS1200-3;SS1200-4;SS100-4;SS1200-5

VEVOR

Affordable. Reliable. Home Improvement.

Freistehender Edelstahl Stahlspüle

MODELL: SS100-1; SS1200-1; SS100-2; SS1200-3;

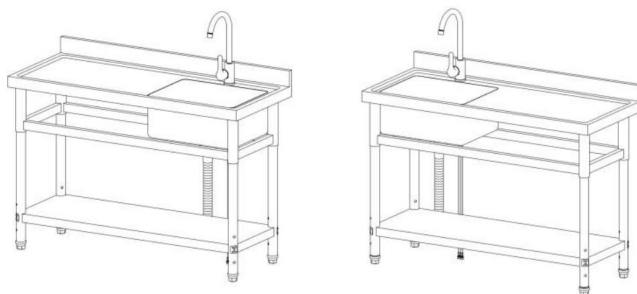

MODELL: SS100-3; SS1200-4; **MODELL:** SS100-4; SS1200-5

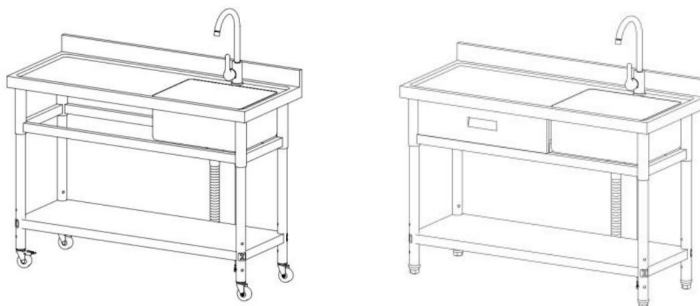

Hinweis: Das Produktbild dient als Referenz, die tatsächlichen Details sind maßgebend

Dies ist die Originalanleitung. Bitte lesen Sie alle Anweisungen sorgfältig durch, bevor Sie das Gerät in Betrieb nehmen. VEVOR behält sich eine klare Auslegung unserer Bedienungsanleitung vor. Das Aussehen des Produkts hängt vom gelieferten Produkt ab. Bitte haben Sie Verständnis dafür, dass wir Sie nicht erneut über Technologie- oder Software-Updates informieren.

Vielen Dank, dass Sie sich für dieses Produkt entschieden haben
Bitte lesen Sie vor der Verwendung alle Anweisungen. Die Informationen helfen Ihnen
um die bestmöglichen Ergebnisse zu erzielen.

Betriebssicherheit

Bitte legen Sie dieses Handbuch an einem leicht einsehbaren Ort ab und bewahren Sie es ordnungsgemäß auf.
In der Bedienungsanleitung wird klar und deutlich erklärt, wie das Gerät sicher und richtig verwendet wird, um Schäden oder
Sachschäden für Sie und andere zu vermeiden.

SICHERHEIT

	Lesen Sie die Bedienungsanleitung.		Vorsicht / Warnung.
	Hinweis / Anmerkung.		Handschuhe tragen



WARNUNG! Lesen und verstehen Sie alle Anweisungen, bevor Sie dieses

Freistehende Spüle aus Edelstahl. Der Bediener muss die grundlegenden

Vorsichtsmaßnahmen zur Verringerung des Risikos von Personenschäden und/oder Schäden am

**Geräte. Bewahren Sie dieses Handbuch für Sicherheitswarnungen, Vorsichtsmaßnahmen, Bedienung oder
Inspektions- und Wartungsanweisungen.**

Bitte machen Sie sich mit den Gefahrenhinweisen in dieser Anleitung vertraut. Ein Hinweis ist
eine Warnung, dass die Möglichkeit von Sachschäden, Verletzungen oder Todesfällen besteht, wenn bestimmte
Anweisungen nicht befolgt werden.

WARNUNG! Lassen Sie sich NICHT durch Bequemlichkeit oder Vertrautheit mit dem Produkt (erworben durch
wiederholte Verwendung) ersetzen die strikte Einhaltung der Werkzeugsicherheitsregeln. Wenn Sie

Wenn Sie dieses Werkzeug unsicher oder falsch verwenden, können Sie ernsthafte Verletzungen erleiden

Verletzung.



Vorsichtsmaßnahmen bei der Montage

1. Nur gemäß dieser Anleitung zusammenbauen. Unsachgemäße Montage kann Gefahren schaffen.
2. Tragen Sie während der Montage ANSI-zugelassene Hochleistungs-Arbeitshandschuhe.
3. Halten Sie den Versammlungsbereich sauber und gut beleuchtet.
4. Halten Sie während der Montage unbeteiligte Personen vom Bereich fern.
5. Nicht im müden Zustand oder unter Alkoholeinfluss montieren,

Drogen oder Medikamente.

6. Gewichtskapazität und andere Produktfähigkeiten gelten für richtig und

Nur komplett montiertes Produkt.

7. Montieren Sie das Gerät auf einer flachen, ebenen, harten und glatten Oberfläche, die
Sicheres Stützen einer voll beladenen Truhe.













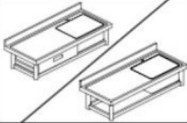





Vorsichtsmaßnahmen treffen







UM SCHWERE VERLETZUNGEN UND TOD DURCH UMKIPPEN ZU VERMEIDEN:

1. NICHT AUF DIESEM ARTIKEL SITZEN, STEHEN ODER KLETTERN.
2. Dieses Produkt ist weder ein Spielzeug noch eine Spielzeugkiste. Erlauben Sie Kindern nicht, damit zu spielen mit oder in der Nähe dieses Artikels.
3. Vor jedem Gebrauch prüfen; nicht verwenden, wenn Teile lose oder beschädigt sind.

Teilleiste

HINWEIS: Für einige Befestigungselemente sind möglicherweise Ersatzteile vorhanden. Bitte achten Sie während Installation.

Parts No.	Picture	Qty	Parts No.	Picture	Qty
(A)		1PC	(J)	 transparent	1PC
(B)		1PC	(K)		1PC
(C)		4PCS	(L)		1PC
(D)		2PCS	(M)		1PC
(E)		2PCS	(N)		1PC
<p>Hinweis: Die Rollen D und E sind nur kompatibel mit Modellen SS100-3 und SS1200-4.</p>			(O)	 White	1PC
(G)		jeder Stil 2PCS	(P)	 Dark blue	1PC
(H)		1PC	(Q)	 Black	1PC
(I)		1PC	(R)		1PC

Parts No.	Picture	Qty	Parts No.	Picture	Qty
Ⓢ		1PC	Ⓧ		1PC
Ⓣ		4PCS			
Ⓤ		4PCS			
Ⓥ		4PCS			
Ⓦ		4PCS			

Montageschritte

1



(A) x1pc



(C) x4pcs

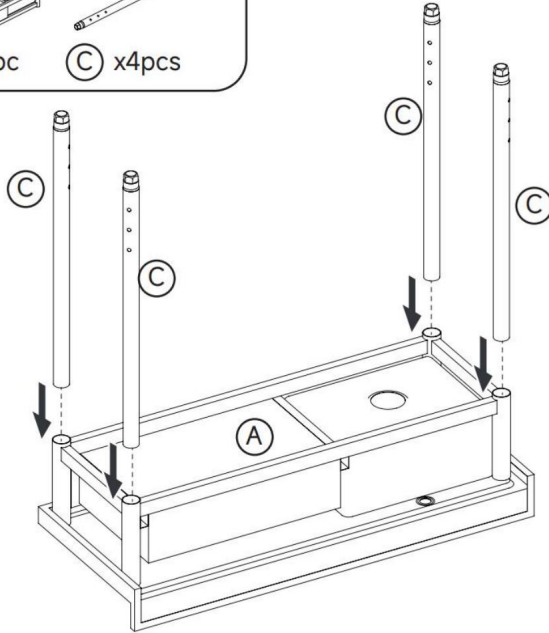

2



(B) x1pc



(T) x4pcs



(U) x4pcs



(V) x4pcs



(W) x4pcs

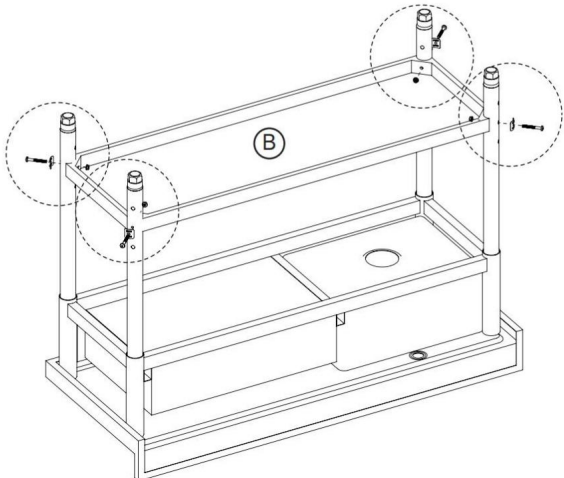
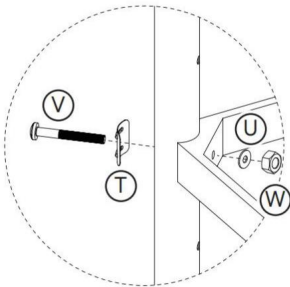

3



D x2pcs



E x2pcs

OR



F x4pcs

Rotate the wheels or adjust the feet as needed

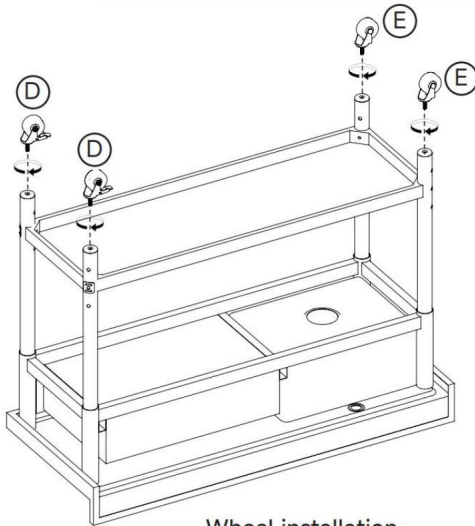

Wheel installation

OR

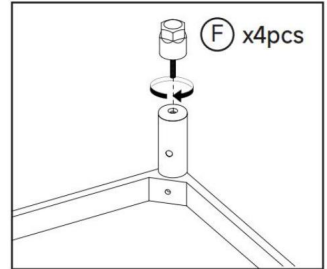

Adjustable foot installation

HINWEIS: Dieser Installationsschritt gilt nur für die Modelle SS100-3 und SS1200-4.
Andere Modelle haben keine Rollen.

4

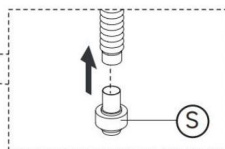
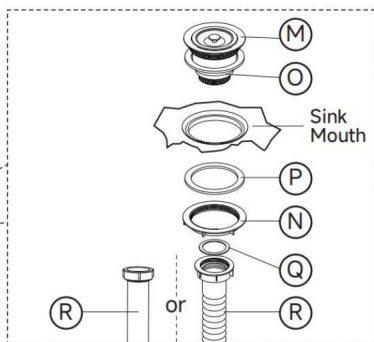
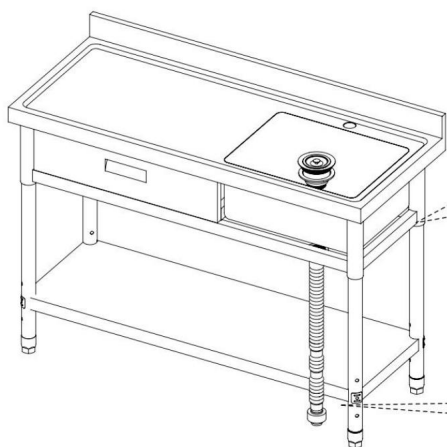
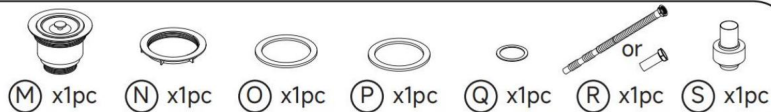

HINWEIS: Der flexible Schlauch R und das starre Rohr R des Abflussrohrs können je nach Verwendungsszenario des Benutzers selektiv installiert werden.

.Im Allgemeinen wird der flexible Schlauch bei der Installation direkt an den Bodenablauf des Gartens angeschlossen. (Abbildung A)

Die Installation von Hartrohren eignet sich grundsätzlich zum Anschluss der Abwasserrohre innerhalb eines Haushalts. (Abbildung B)



B



5



(G) x2pcs



(H) x1pc



(I) x1pc



(J) x1pc



(K) x1pc



(L) x1pc

5-1

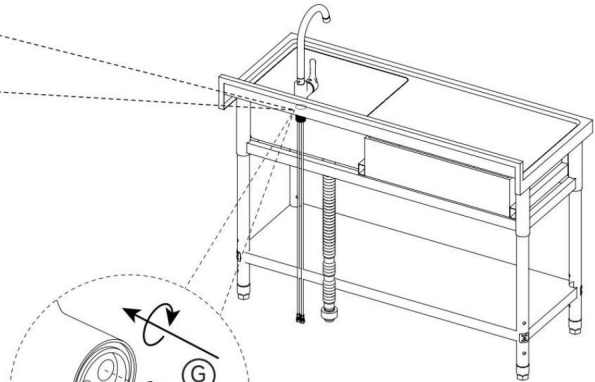
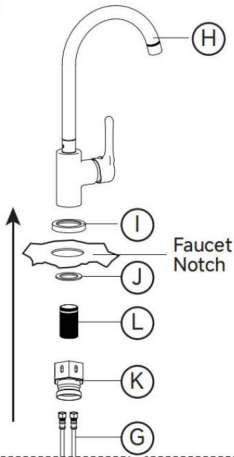

5-2

Align the red pattern tube (G) to the red port.
Align the blue pattern tube (G) to the blue port.

6

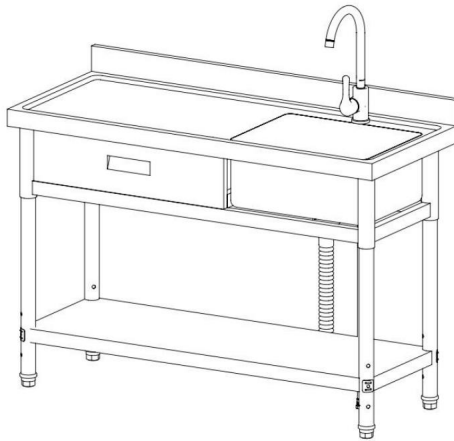

Completed

PFLEGE UND WARTUNG

Reinigung:

Nach Gebrauch das Wasser auf der Abtropffläche und dem Waschbecken mit einem Tuch.

Sollten sich Rostflecken oder hartnäckige Flecken auf der Oberfläche befinden, wischen Sie diese bitte mit dem kostenlosen Scheuerschwamm ab.

Beachten:

Überprüfen Sie regelmäßig, ob die Schrauben am Produkt locker sind und ziehen Sie diese regelmäßig fest.

Hersteller: Shanghaimuxinmuyeyouxiangongsi **Adresse:**

Shuangchenglu 803nong11hao1602A-1609shi, baoshanqu, Shanghai 200000 CN.

Importiert nach AUS: SIHAO PTY LTD. 1 ROKEVA STREETEASTWOOD NSW 2122
Australien

Importiert in die USA: Sanven Technology Ltd. Suite 250, 9166 Anaheim Place,
Rancho Cucamonga, CA 91730



YH CONSULTING LIMITED. C/O YH Consulting Limited,
Büro 147, Centurion House, London Road, Staines-upon-
Thames, Surrey, TW18 4AX



E-CrossStu GmbH
Mainzer Landstr.69,
60329 Frankfurt am Main.



VEVOR

Affordable. Reliable. Home Improvement.

Lavello in acciaio inossidabile indipendente

MODELLO: SS100-1; SS1200-1; SS100-2; SS100-3;
SS1200-3;SS1200-4;SS100-4;SS1200-5

VEVOR

Affordable. Reliable. Home Improvement.

Inox autoportante
Lavello in
acciaio

MODELLO: SS100-1; SS1200-1; SS100-2; SS1200-3;

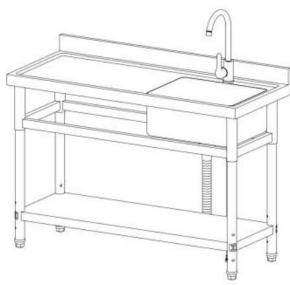

MODELLO:SS100-3; SS1200-4; **MODELLO:**SS100-4; SS1200-5



Nota: l'immagine del prodotto è solo di riferimento, i dettagli reali prevarranno

Queste sono le istruzioni originali, si prega di leggere attentamente tutte le istruzioni del manuale prima dell'uso. VEVOR si riserva la piena interpretazione del proprio manuale utente. L'aspetto del prodotto dipenderà dal prodotto ricevuto. Vi preghiamo di scusarci se non vi informeremo più in caso di aggiornamenti tecnologici o software sul nostro prodotto.

Grazie mille per aver scelto questo prodotto



Si prega di leggere tutte le istruzioni prima di utilizzarlo. Le informazioni ti aiuteranno ottenere i migliori risultati possibili.

Sicurezza operativa

Si prega di conservare questo manuale in un luogo facilmente consultabile e di conservarlo correttamente.

Il manuale di istruzioni indica chiaramente come utilizzare l'attrezzatura in modo sicuro e corretto, in modo da prevenire danni o perdite di proprietà causati a te e ad altri.

SICUREZZA

	Leggere il manuale di istruzioni.		Attenzione / Avvertenza.
	Nota / Osservazione.		indossare i guanti



ATTENZIONE! Leggere e comprendere tutte le istruzioni prima di utilizzare questo Lavello in acciaio inox indipendente. L'operatore deve seguire le istruzioni di base precauzioni per ridurre il rischio di lesioni personali e/o danni all'attrezzatura. Conservare questo manuale per le avvertenze di sicurezza, le precauzioni, il funzionamento o istruzioni di ispezione e manutenzione.

Si prega di prendere visione delle avvertenze di pericolo contenute nel presente manuale. Un avviso è un avviso che c'è la possibilità di danni alla proprietà, lesioni o morte se certi le istruzioni non vengono seguite.

ATTENZIONE! NON lasciare che la familiarità o il comfort con il prodotto (acquisiti da uso ripetuto) sostituire la rigorosa osservanza delle norme di sicurezza dell'utensile. Se utilizzare questo strumento in modo non sicuro o non corretto, potresti subire gravi danni personali infortunio.



Precauzioni di montaggio

1. Assemblare solo secondo queste istruzioni. Un assemblaggio improprio può creare pericoli.
2. Durante il montaggio, indossare guanti da lavoro resistenti omologati ANSI.
3. Mantenere l'area di assemblaggio pulita e ben illuminata.
4. Tenere gli astanti fuori dall'area durante l'assemblaggio.
5. Non riunirsi quando si è stanchi o sotto l'effetto dell'alcool,

farmaci o medicinali.

6. La capacità di peso e altre capacità del prodotto si applicano correttamente e solo prodotto completamente assemblato.

7. Montare su una superficie piana, livellata, dura e liscia in grado di sostenere in modo sicuro un baule completamente carico.













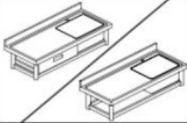





Precauzioni d'uso







PER PREVENIRE LESIONI GRAVI E MORTALI DOVUTE AL RIBALTAMENTO:

1. NON SEDERSI, STARE IN PIEDI O SALIRE SU QUESTO ARTICOLO.
2. Questo prodotto non è un giocattolo né un baule portagiochi. Non permettere ai bambini di giocare con o vicino a questo articolo.
3. Ispezionare prima di ogni utilizzo; non utilizzare se alcune parti sono allentate o danneggiate.

Elenco delle parti

NOTA: Alcuni elementi di fissaggio potrebbero avere parti di ricambio. Prestare attenzione durante installazione.

Parts No.	Picture	Qty	Parts No.	Picture	Qty
(A)		1PC	(J)	 transparent	1PC
(B)		1PC	(K)		1PC
(C)		4PCS	(L)		1PC
(D)		2PCS	(M)		1PC
(E)		2PCS	(N)		1PC
<p>Nota: le rotelle D ed E sono solo compatibile con i modelli SS100-3 e SS1200-4.</p>			(O)	 White	1PC
(G)		ogni stile 2PCS	(P)	 Dark blue	1PC
(H)		1PC	(Q)	 Black	1PC
(I)		1PC	(R)		1PC

Parts No.	Picture	Qty	Parts No.	Picture	Qty
Ⓢ		1PC	Ⓧ		1PC
Ⓣ		4PCS			
Ⓤ		4PCS			
Ⓥ		4PCS			
Ⓦ		4PCS			

Fasi di assemblaggio

1



(A) x1pc



(C) x4pcs

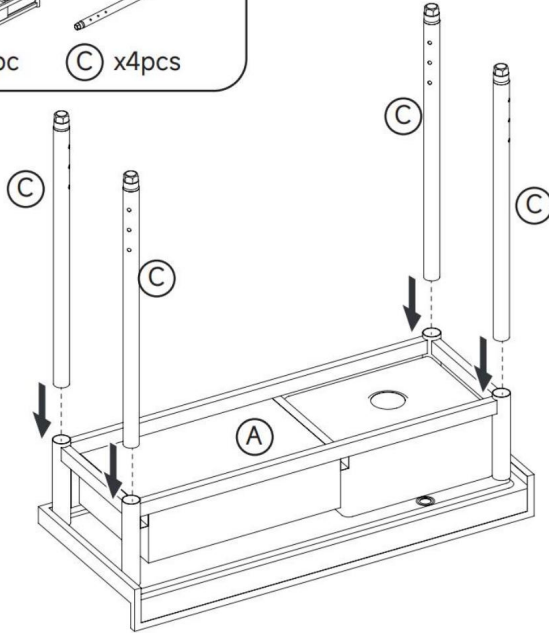

2



(B) x1pc



(T) x4pcs



(U) x4pcs



(V) x4pcs



(W) x4pcs

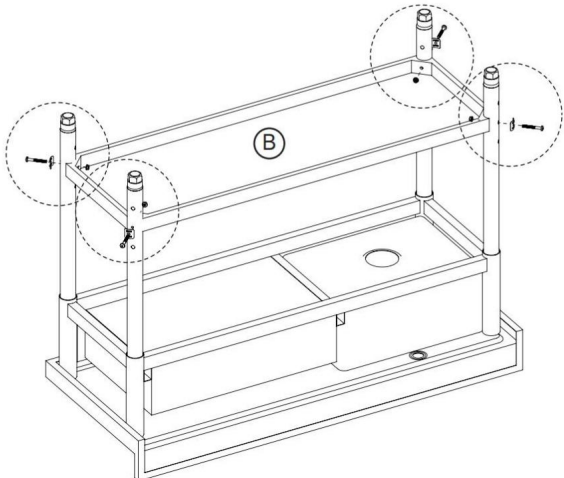
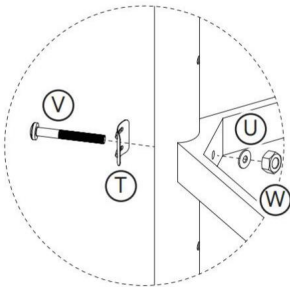

3



D x2pcs



E x2pcs

OR



F x4pcs

Rotate the wheels or adjust the feet as needed

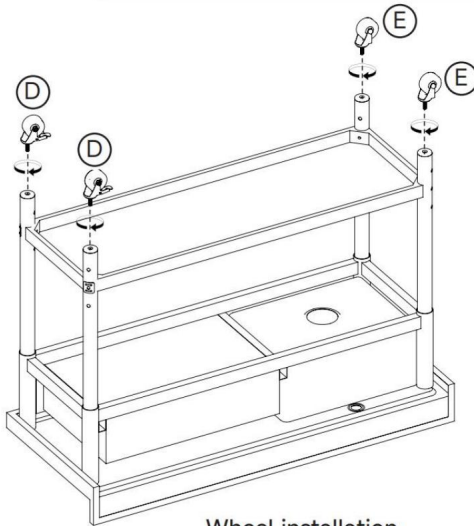

Wheel installation

OR

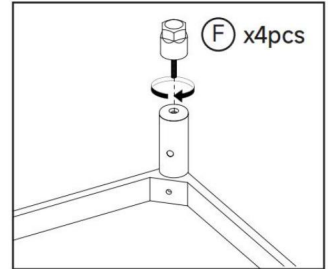

Adjustable foot installation

NOTA: questa fase di installazione è applicabile solo ai modelli SS100-3 e SS1200-4. Gli altri modelli non sono dotati di ruote girevoli.

4

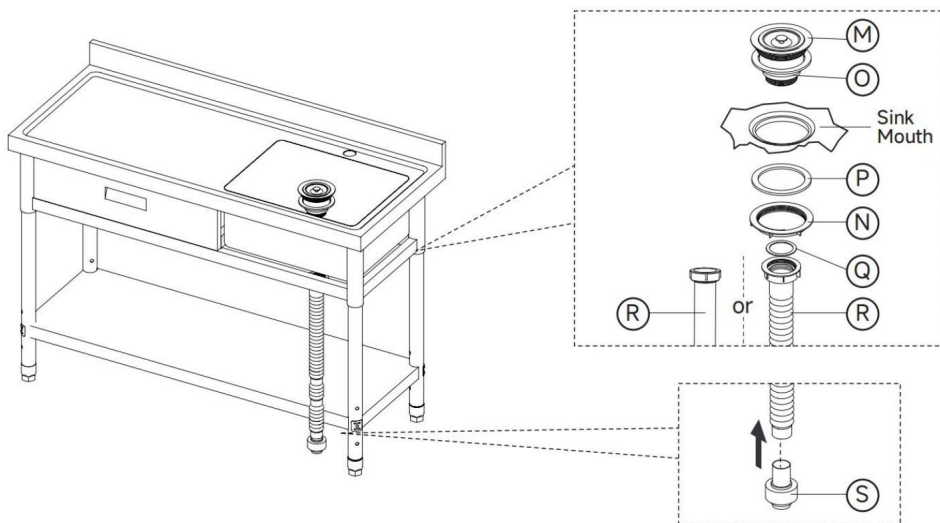
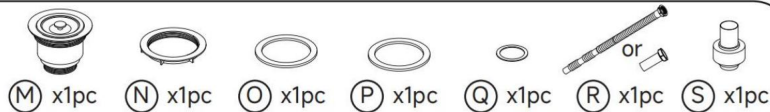

NOTA: il tubo flessibile R e il tubo rigido R del tubo di drenaggio possono essere installati in modo selettivo in base allo scenario di utilizzo dell'utente.

In genere, quando si installa il tubo flessibile, questo viene collegato direttamente allo scarico a terra del giardino. (Figura A)

L'installazione di tubi rigidi è generalmente adatta per collegare le condotte fognarie all'interno di un'abitazione. (Figura B)

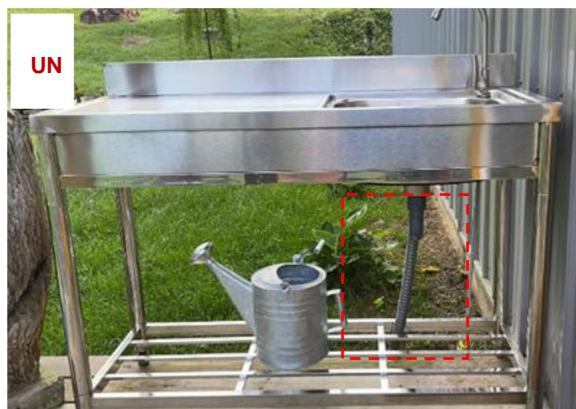

B



5



(G) x2pcs



(H) x1pc



(I) x1pc



(J) x1pc



(K) x1pc



(L) x1pc

5-1

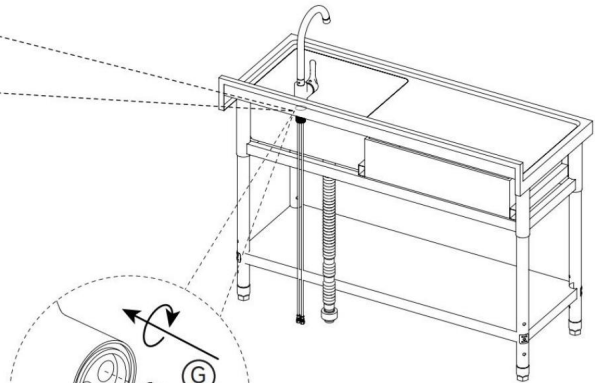
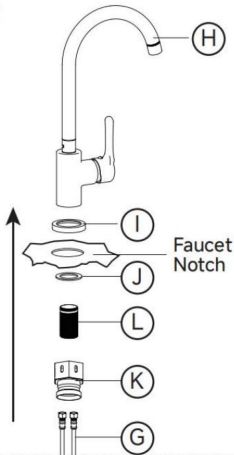

5-2

Align the red pattern tube (G) to the red port.
Align the blue pattern tube (G) to the blue port.

6

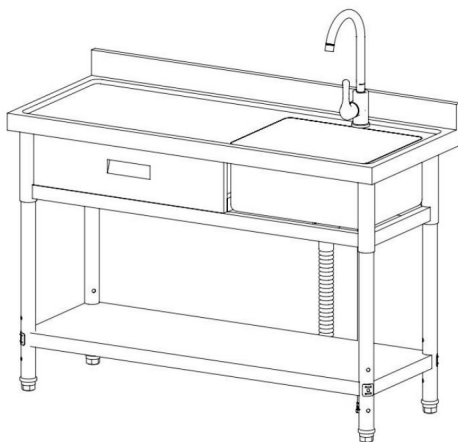

Completed

CURA E MANUTENZIONE

Pulizia:

Dopo l'uso, assicurarsi di asciugare l'acqua sulla piattaforma di scarico e sul lavandino con un stoffa.

Allo stesso tempo, se sulla superficie sono presenti macchie di ruggine o segni difficili da trattare, pulirli con la spugna abrasiva in omaggio.

Avviso:

Controllare regolarmente che le viti del prodotto non siano allentate e serrarle regolarmente.

Produttore: Shanghaimuxinmuyeyouxiangongsi **Indirizzo:**

Shuangchenglu 803nong11hao1602A-1609shi, baoshanqu, shanghai 200000 CN.

Importato in AUS: SIHAO PTY LTD. 1 ROKEVA STREETEASTWOOD NSW 2122
Australia

Importato negli USA: Sanven Technology Ltd. Suite 250, 9166 Anaheim Place,
Rancho Cucamonga, CA 91730



YH CONSULTING LIMITED. C/O YH Consulting Limited
Ufficio 147, Centurion House, London Road, Staines-
upon-Thames, Surrey, TW18 4AX

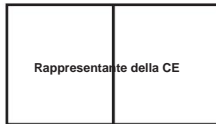

E-CrossStu GmbH
Mainzer Landstr.69,
60329 Francoforte sul Meno.



VEVOR

Affordable. Reliable. Home Improvement.

Fregadero de acero inoxidable independiente

MODELO: SS100-1;SS1200-1;SS100-2;SS100-3;
SS1200-3;SS1200-4;SS100-4;SS1200-5

VEVOR

Affordable. Reliable. Home Improvement.

Acero inoxidable independiente
Fregadero de
acero

MODELO: SS100-1; SS1200-1; SS100-2; SS1200-3;

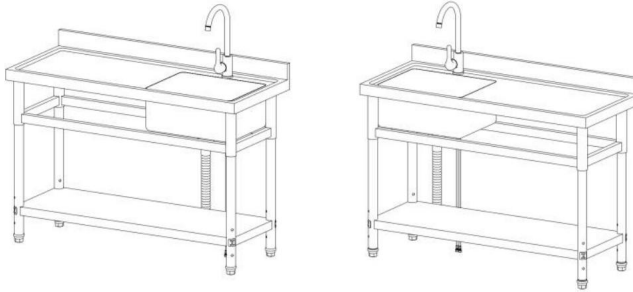

MODELO: SS100-3; SS1200-4; MODELO: SS100-4; SS1200-5

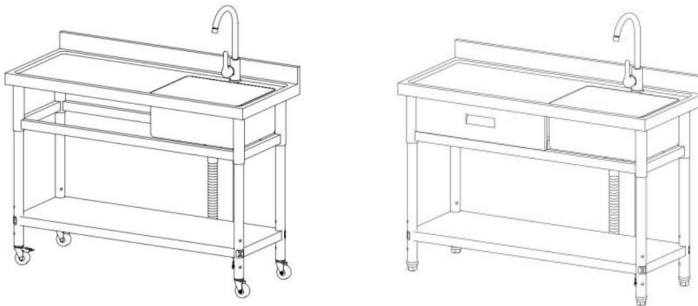

Nota: La imagen del producto es de referencia, prevalecerán los detalles reales.

Estas son las instrucciones originales; lea atentamente todas las instrucciones del manual antes de utilizarlo. VEVOR se reserva el derecho de interpretar su manual de usuario. La apariencia del producto dependerá del producto que haya recibido. Le rogamos que nos disculpe si no le informamos de nuevo si hay actualizaciones tecnológicas o de software en nuestro producto.

Muchas gracias por elegir este producto.

Lea todas las instrucciones antes de usarlo. La información le ayudará.

lograr los mejores resultados posibles.

Seguridad de operación

Por favor, guarde este manual en un lugar fácil de consultar y consérvelo adecuadamente.

El manual de instrucciones indica claramente cómo utilizar el equipo de forma segura y correcta, a fin de evitar cualquier daño o pérdida de propiedad causada a usted o a otras personas.

SEGURIDAD

	Lea el manual de instrucciones.		Precaución / Advertencia.
	Nota/Observación.		usar guantes



¡ADVERTENCIA! Lea y comprenda todas las instrucciones antes de usar este producto.

Fregadero independiente de acero inoxidable. El operador debe seguir las normas básicas.

precauciones para reducir el riesgo de lesiones personales y/o daños a la

equipo. Conserve este manual para advertencias de seguridad, precauciones, funcionamiento o

Instrucciones de inspección y mantenimiento.

Familiarícese con los avisos de peligro que se encuentran en este manual. Un aviso es

una alerta de que existe la posibilidad de daños a la propiedad, lesiones o muerte si se producen ciertas

No se siguen las instrucciones.

¡ADVERTENCIA! NO permita que la comodidad o familiaridad con el producto (adquirida a través de

uso repetido) reemplazan el estricto cumplimiento de las normas de seguridad de la herramienta. Si usted

Si utiliza esta herramienta de forma insegura o incorrecta, puede sufrir lesiones personales graves.

lesión.



Precauciones de montaje

1. Realice el montaje únicamente de acuerdo con estas instrucciones. Un montaje incorrecto puede crear peligros.
2. Use guantes de trabajo resistentes aprobados por ANSI durante el montaje.
3. Mantenga el área de montaje limpia y bien iluminada.
4. Mantenga a los transeúntes fuera del área durante el montaje.
5. No realice el montaje cuando esté cansado o bajo los efectos del alcohol.

drogas o medicamentos.

6. La capacidad de peso y otras capacidades del producto se aplican de manera adecuada y Solo producto completamente ensamblado.

7. Montar sobre una superficie plana, nivelada, dura y lisa capaz de soportar Sosteniendo de forma segura un cofre completamente cargado.













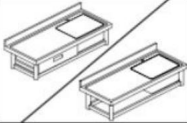





Precauciones de uso







PARA EVITAR LESIONES GRAVES Y LA MUERTE POR VUELCO:

1. NO SE SIENTA, SE PARE NI SE SUBA SOBRE ESTE ARTÍCULO.
2. Este producto no es un juguete ni un baúl de juguetes. No permita que los niños jueguen con él. con o cerca de este artículo.
3. Inspeccione antes de cada uso; no lo utilice si las piezas están sueltas o dañadas.

Lista de piezas

NOTA: Algunos sujetadores pueden tener piezas de repuesto. Preste atención durante instalación.

Parts No.	Picture	Qty	Parts No.	Picture	Qty
(A)		1PC	(J)	 transparent	1PC
(B)		1PC	(K)		1PC
(C)		4PCS	(L)		1PC
(D)		2PCS	(M)		1PC
(E)		2PCS	(N)		1PC
<p>Nota: Las ruedas D y E son solo compatibles con los modelos SS100-3 y SS1200-4.</p>			(O)	 White	1PC
(G)		cada estilo 2PCS	(P)	 Dark blue	1PC
(H)		1PC	(Q)	 Black	1PC
(I)		1PC	(R)		1PC

Parts No.	Picture	Qty	Parts No.	Picture	Qty
Ⓢ		1PC	Ⓧ		1PC
Ⓣ		4PCS			
Ⓤ		4PCS			
Ⓥ		4PCS			
Ⓦ		4PCS			

Pasos de montaje

1



(A) x1pc



(C) x4pcs

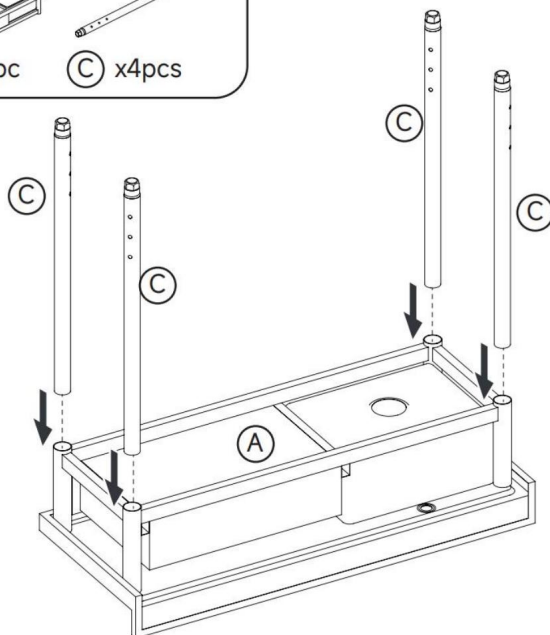

2



(B) x1pc



(T) x4pcs



(U) x4pcs



(V) x4pcs



(W) x4pcs

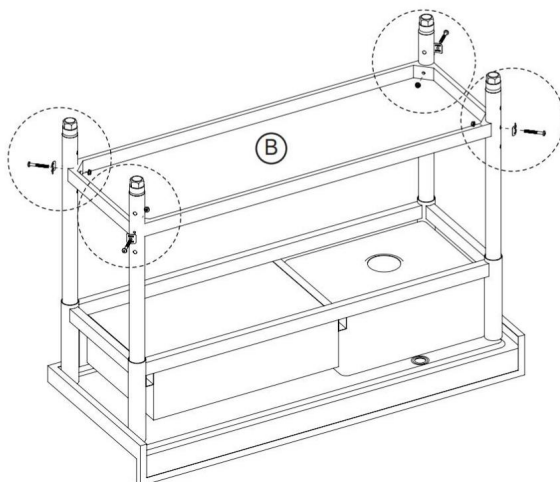
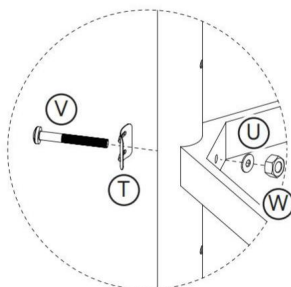

3



D x2pcs



E x2pcs

OR



F x4pcs

Rotate the wheels or adjust the feet as needed

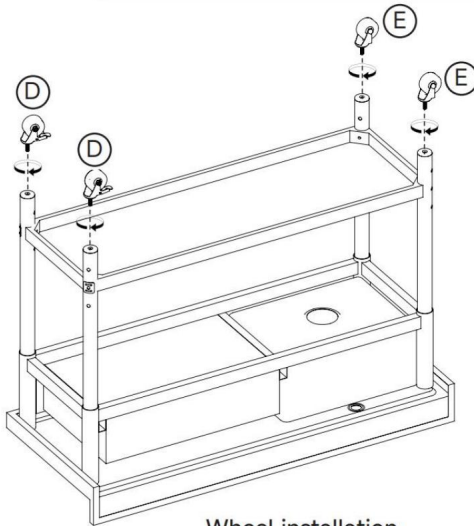

Wheel installation

OR

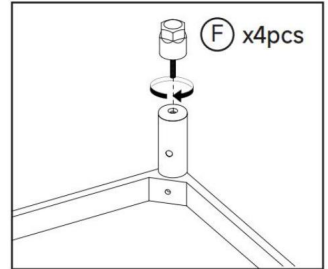

Adjustable foot installation

NOTA: Este paso de instalación solo aplica a los modelos SS100-3 y SS1200-4. Los demás modelos no tienen ruedas.

4

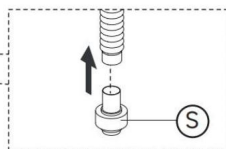
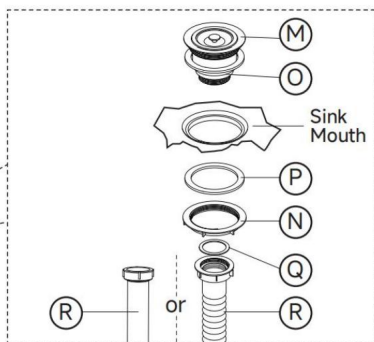
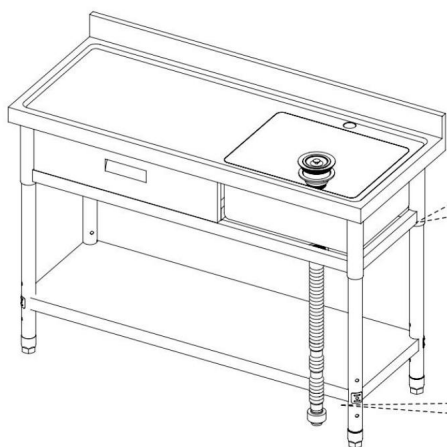
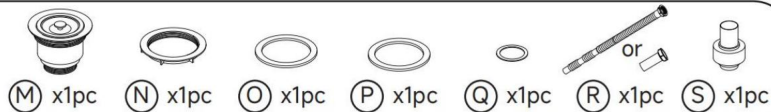

NOTA: La manguera flexible R y el tubo rígido R del tubo de drenaje se pueden instalar de forma selectiva según el escenario de uso del usuario.

En términos generales, al instalar la manguera flexible, se conecta directamente al drenaje del suelo del jardín. (Figura A)

La instalación de tuberías duras generalmente es adecuada para conectar las tuberías de alcantarillado dentro de una casa. (Figura B)

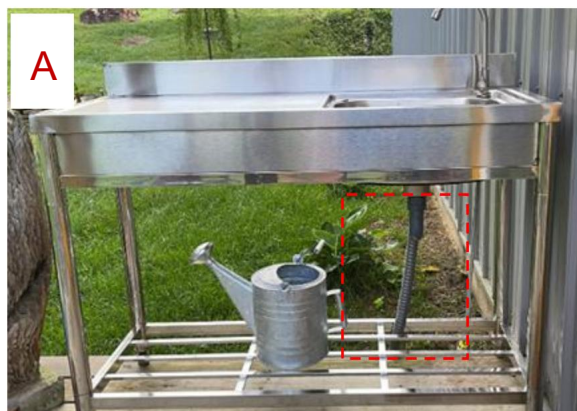

B

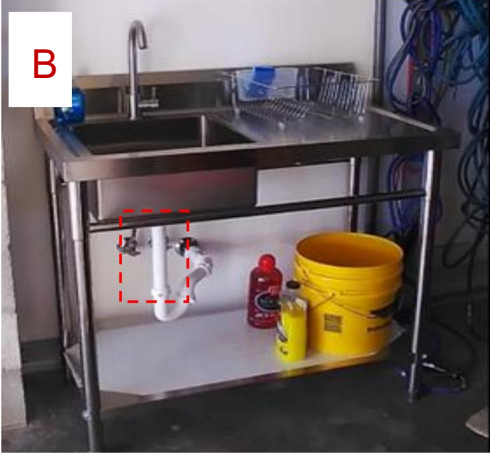

5



G x2pcs



H x1pc



I x1pc



J x1pc



K x1pc



L x1pc

5-1

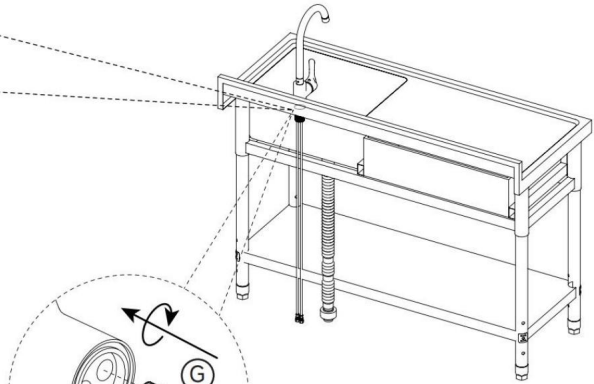
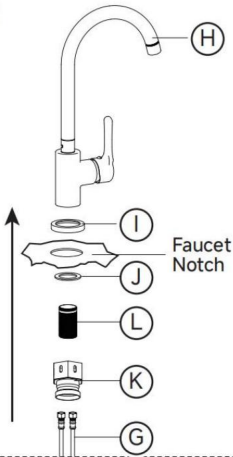

5-2

Align the red pattern tube (G) to the red port.
Align the blue pattern tube (G) to the blue port.

6

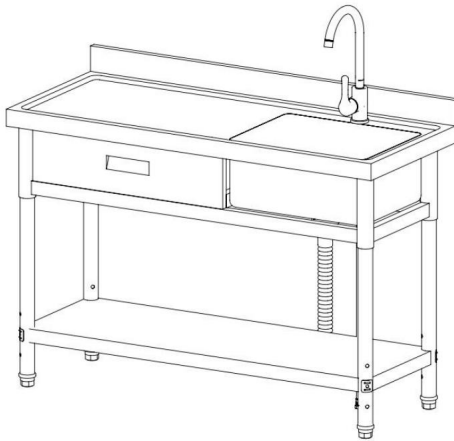

Completed

CUIDADO Y MANTENIMIENTO

Limpieza:

Después de su uso, asegúrese de secar el agua en la plataforma de drenaje y el fregadero con un paño.

Al mismo tiempo, si hay manchas de óxido o marcas difíciles de tratar en la superficie, límpielas con el estropajo de cortesía.

Aviso:

Compruebe periódicamente si los tornillos del producto están flojos y apriételos periódicamente.

Fabricante: Shanghaimuxinmuyeyouxiangongsi Dirección:
Shuangchenglu 803nong11hao1602A-1609shi, baoshanqu, shanghai 200000 CN.

Importado a AUS: SIHAO PTY LTD. 1 ROKEVA STREET, EASTWOOD, NSW 2122,
Australia

Importado a EE. UU.: Sanven Technology Ltd. Suite 250, 9166 Anaheim Place,
Rancho Cucamonga, CA 91730

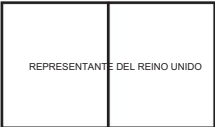

YH CONSULTING LIMITADA. A/C YH Consulting Limited
Oficina 147, Centurion House, London Road, Staines-
upon-Thames, Surrey, TW18 4AX

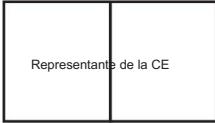

E-CrossStu GmbH
Mainzer Landstr.69,
60329 Fráncfort del Meno.



VEVOR

Affordable. Reliable. Home Improvement.

Wolnostojący zlew ze stali nierdzewnej

MODEL: SS100-1SS1200-1SS100-2SS100-3

SS1200-3; SS1200-4; SS100-4; SS1200-5

VEVOR

Affordable. Reliable. Home Improvement.

Wolnostojący ze stali nierdzewnej
Zlew stalowy

MODEL: SS100-1; SS1200-1; SS100-2; SS1200-3;



MODEL:SS100-3; SS1200-4; MODEL:SS100-4; SS1200-5



Uwaga: Zdjęcie produktu ma charakter poglądowy, decydujące znaczenie mają rzeczywiste szczegóły.

To jest oryginalna instrukcja obsługi. Przed użyciem prosimy o dokładne zapoznanie się z treścią instrukcji. Firma VEVOR zastrzega sobie prawo do jednoznacznej interpretacji niniejszej instrukcji obsługi. Wygląd produktu zależy od stanu, w jakim go otrzymali Państwo. Prosimy o wyrozumiałość, ale nie będziemy Państwa ponownie informować o aktualizacjach technologicznych lub oprogramowania naszego produktu.

Dziękujemy bardzo za wybór tego produktu

Przed użyciem należy przeczytać wszystkie instrukcje. Informacje te będą pomocne. osiągnąć najlepsze możliwe wyniki.

Bezpieczeństwo operacyjne

Prosimy o umieszczenie niniejszej instrukcji w miejscu łatwo dostępnym i prawidłowe jej przechowywanie.

Instrukcja obsługi wyraźnie wskazuje, jak prawidłowo i bezpiecznie korzystać ze sprzętu, aby zapobiec jakimkolwiek szkodom lub stratom materialnym, które mogą powstać u Ciebie i innych osób.

BEZPIECZEŃSTWO

	Przeczytaj instrukcję obsługi.		Uwaga / Ostrzeżenie.
	Uwaga/Uwaga.		nosić rękawiczki



OSTRZEŻENIE! Przed użyciem należy przeczytać i zrozumieć wszystkie instrukcje.

Wolnostojący zlew ze stali nierdzewnej. Operator musi przestrzegać podstawowych zasad środki ostrożności mające na celu zmniejszenie ryzyka obrażeń ciała i/lub uszkodzenia sprzętu. Zachowaj tę instrukcję ze względu na ostrzeżenia dotyczące bezpieczeństwa, środki ostrożności, obsługę lub instrukcje dotyczące przeglądów i konserwacji.

Prosimy o zapoznanie się z ostrzeżeniami dotyczącymi zagrożeń zawartymi w niniejszej instrukcji. Ostrzeżenie jest ostrzeżenie, że istnieje możliwość uszkodzenia mienia, obrażeń ciała lub śmierci w przypadku wystąpienia pewnych instrukcje nie są przestrzegane.

OSTRZEŻENIE! NIE pozwól, aby komfort lub znajomość produktu (nabyta z wielokrotnego użytku) zastępuje ścisłe przestrzeganie zasad bezpieczeństwa narzędzi. Jeśli Niewłaściwe lub niebezpieczne używanie tego narzędzia może skutkować poważnymi obrażeniami ciała obrażenia.



Środki ostrożności podczas montażu

1. Montaż należy wykonywać wyłącznie zgodnie z niniejszą instrukcją. Nieprawidłowy montaż może spowodować stwarzać zagrożenia.
2. Podczas montażu należy nosić wytrzymałe rękawice robocze zatwierdzone przez ANSI.
3. Utrzymuj miejsce zgromadzeń w czystości i dobrym oświetleniu.
4. Podczas montażu nie dopuszczać osób postronnych na teren montażu.
5. Nie należy gromadzić się w stanie zmęczenia lub pod wpływem alkoholu,

narkotyki lub leki.

6. Nośność i inne możliwości produktu mają zastosowanie w przypadku prawidłowego i

Tylko produkt całkowicie zmontowany.

7. Montaż należy wykonać na płaskiej, równej, twardej i gładkiej powierzchni,

Bezpieczne podtrzymywanie w pełni załadowanej skrzyni.



Zachowaj środki ostrożności

ABY ZAPOBIEC POWAŻNYM OBRAŻENIOM I ŚMIERCI SPOWODOWANEJ PRZEWRÓCENIEM:

1. NIE WOLNO SIEDZIEĆ, STOJEĆ ANI WSPINAĆ SIĘ NA TYM PRZEDMIOCIE.











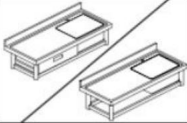





2. Ten produkt nie jest zabawką ani skrzynią na zabawki. Nie pozwalaj dzieciom bawić się nim.







z tym przedmiotem lub w jego pobliżu.

3. Przed każdym użyciem należy przeprowadzić kontrolę. Nie należy używać produktu, jeśli jakieś części są luźne lub uszkodzone.

Lista części

UWAGA: Niektóre elementy złączne mogą mieć części zamienne. Prosimy o zachowanie ostrożności podczas instalacji.

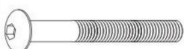
Parts No.	Picture	Qty	Parts No.	Picture	Qty
(A)		1PC	(J)	 transparent	1PC
(B)		1PC	(K)		1PC
(C)		4PCS	(L)		1PC
(D)		2PCS	(M)		1PC
(E)		2PCS	(N)		1PC
Uwaga: kółka D i E są dostępne tylko kompatybilny z modelami SS100-3 i SS1200-4.			(O)	 White	1PC
(G)		każdy styl 2PCS	(P)	 Dark blue	1PC
(H)		1PC	(Q)	 Black	1PC
(I)		1PC	(R)		1PC

Parts No.	Picture	Qty	Parts No.	Picture	Qty
Ⓢ		1PC	Ⓧ		1PC
Ⓣ		4PCS			
Ⓤ		4PCS			
Ⓥ		4PCS			
Ⓦ		4PCS			

Kroki montażu

1



(A) x1pc



(C) x4pcs

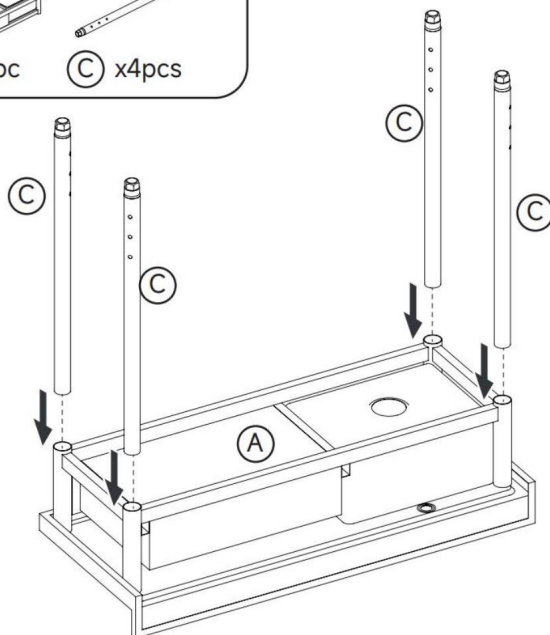

2



(B) x1pc



(T) x4pcs



(U) x4pcs



(V) x4pcs



(W) x4pcs

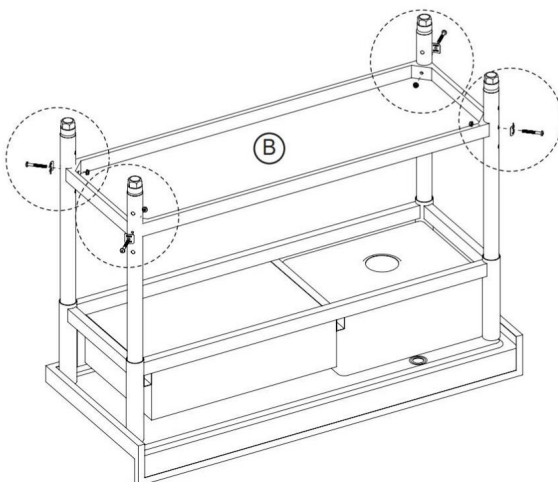
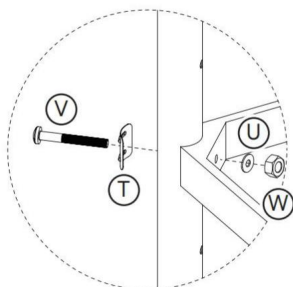

3



D x2pcs



E x2pcs

OR



F x4pcs

Rotate the wheels or adjust the feet as needed

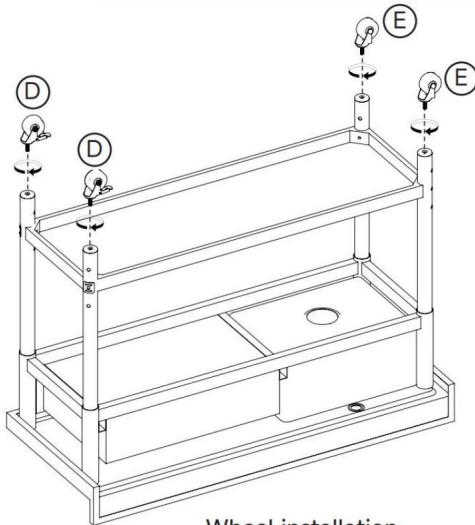

Wheel installation

OR

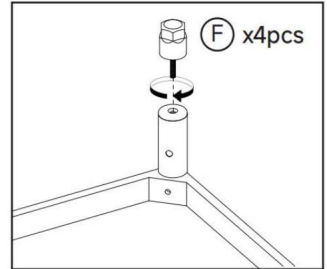

Adjustable foot installation

UWAGA: Ten krok instalacji dotyczy tylko modeli SS100-3 i SS1200-4. Pozostałe modele nie posiadają kółek.

4

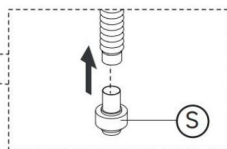
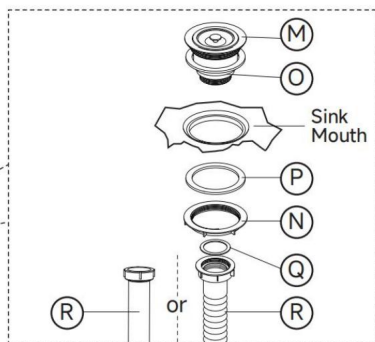
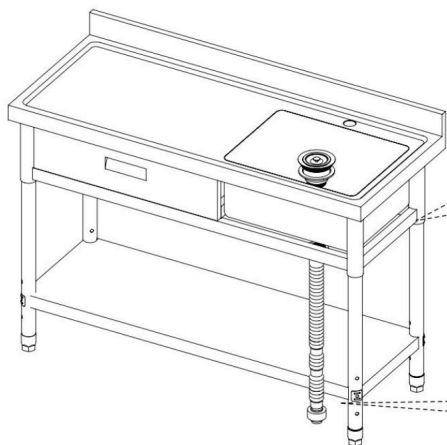
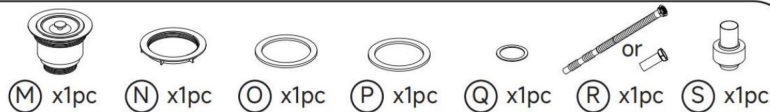

UWAGA: Elastyczny węz R i sztywną rurę R rury spustowej można selektywnie zainstalować zależnie od sposobu użytkowania przez użytkownika.

Ogólnie rzecz biorąc, podczas montażu węża elastycznego należy go podłączyć bezpośrednio do odpływu gruntowego w ogrodzie. (Rysunek A)



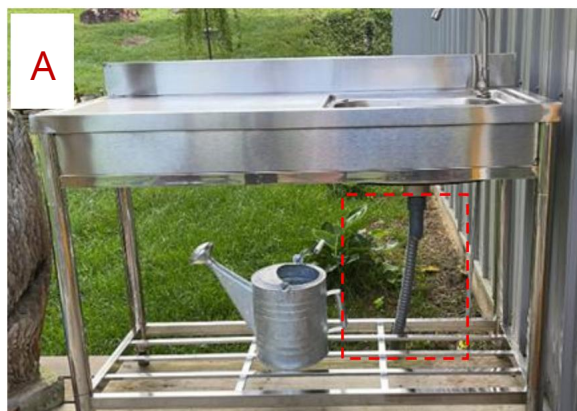

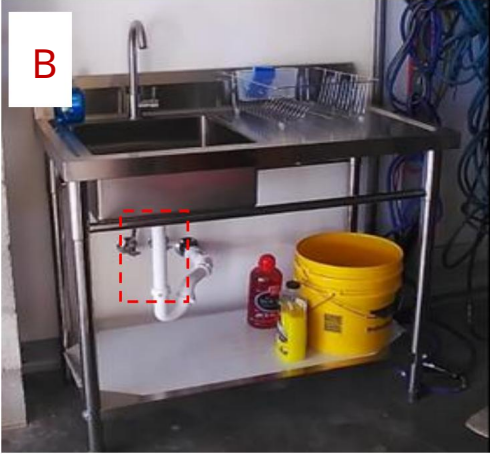

Montaż rur sztywnych jest na ogół odpowiedni do podłączania rur kanalizacyjnych wewnątrz gospodarstwa domowego. (Rysunek B)



B



5

-  (G) x2pcs
-  (H) x1pc
-  (I) x1pc
-  (J) x1pc
-  (K) x1pc
-  (L) x1pc

5-1

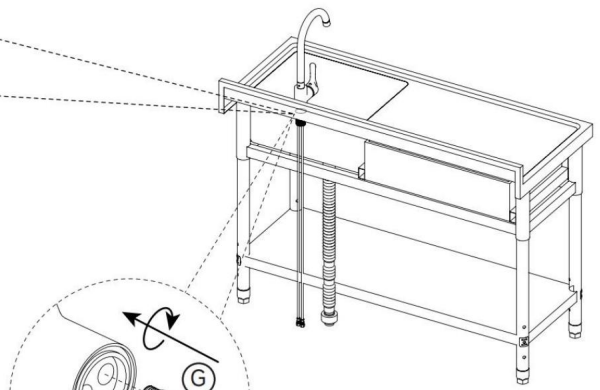
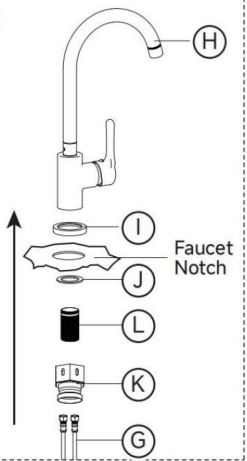

Align the red pattern tube (G) to the red port.
Align the blue pattern tube (G) to the blue port.

6

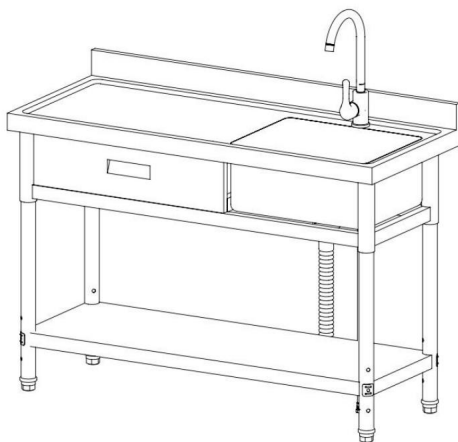

Completed

PIELĘGNACJA I KONSERWACJA

Czyszczenie:

Po użyciu należy dokładnie osuszyć wodę na platformie odpływowej i w zlewie za pomocą ściereczki. płótno.

Jednocześnie, jeśli na powierzchni znajdują się plamy rdzy lub trudne do usunięcia ślady, należy je przetrzeć dołączoną gąbką szorującą

Ogłoszenie:

Należy regularnie sprawdzać, czy śruby produktu nie są poluzowane i dokręcać je.

Producent: Shanghaimuxinmuyeyouxiangongsi Adres:

Shuangchenglu 803nong11hao1602A-1609shi, baoshanqu, szanghaj 200000 CN.

Importowane do Australii: SIHAO PTY LTD. 1 ROKEVA STREETEASTWOOD NSW 2122
Australia

Importowane do USA: Sanven Technology Ltd. Suite 250, 9166 Anaheim Place, Rancho
Cucamonga, CA 91730

REP WIELKIEJ BRYTANII	
-----------------------	--

YH CONSULTING LIMITED. C/O YH Consulting Limited Biuro
147, Centurion House, London Road, Staines-upon-
Thames, Surrey, TW18 4AX

Przedstawiciel WE	
-------------------	--

E-CrossStu GmbH
Mainzer Landstr.69,
60329 Frankfurt nad Menem.



VEVOR

Affordable. Reliable. Home Improvement.

Vrijstaande roestvrijstalen spoelbak

MODEL: SS100-1ÿSS1200-1ÿSS100-2ÿSS100-3ÿ
SS1200-3ÿSS1200-4;SS100-4ÿSS1200-5

VEVOR

Affordable. Reliable. Home Improvement.

Vrijstaande roestvrijstalen
Stalen
spoelbak y

MODEL: SS100-1; SS1200-1; SS100-2; SS1200-3;



MODEL: SS100-3; SS1200-4; MODEL: SS100-4; SS1200-5



Let op: De productfoto is ter referentie, de werkelijke details zijn bepalend.

Dit is de originele handleiding. Lees alle instructies zorgvuldig door voordat u het product gebruikt. VEVOR behoudt zich het recht voor om de gebruiksaanwijzing duidelijk te interpreteren. Het uiterlijk van het product is afhankelijk van het product dat u hebt ontvangen. Neemt u het ons niet kwalijk dat we u niet meer op de hoogte stellen van eventuele technologische of software-updates voor ons product.

Hartelijk dank voor het kiezen van dit product

Lees alle instructies aandachtig door voordat u het gebruikt. De informatie zal u helpen om de best mogelijke resultaten te behalen.

Bedrijfsveiligheid

Bewaar deze handleiding op een plaats waar u hem gemakkelijk kunt raadplegen en bewaar hem op de juiste manier.

In de gebruiksaanwijzing staat duidelijk aangegeven hoe u het apparaat veilig en correct gebruikt, zodat u en anderen geen schade of verlies van eigendommen oplopen.

VEILIGHEID

	Lees de gebruiksaanwijzing.		Let op / Waarschuwing.
	Opmerking.		draag handschoenen



WAARSCHUWING! Lees en begrijp alle instructies voordat u dit product gebruikt.

Vrijstaande roestvrijstalen spoelbak. De gebruiker moet de basisregels volgen.

voorzorgsmaatregelen om het risico op persoonlijk letsel en/of schade aan de

apparatuur. Bewaar deze handleiding voor veiligheidswaarschuwingen, voorzorgsmaatregelen, bedienings- of inspectie- en onderhoudsinstructies.

Maak uzelf vertrouwd met de waarschuwingen voor gevaren in deze handleiding. Een waarschuwing is een waarschuwing dat er een mogelijkheid is van materiële schade, letsel of overlijden als bepaalde Instructies worden niet opgevolgd.

WAARSCHUWING! LAAT GEEN comfort of vertrouwdheid met het product (verkregen door

(herhaaldelijk gebruik) vervangt strikte naleving van de veiligheidsvoorschriften voor gereedschap. Als u

Als u dit gereedschap onveilig of verkeerd gebruikt, kunt u ernstige persoonlijke schade oplopen

blessure.



Voorzorgsmaatregelen voor montage

1. Monteer het apparaat uitsluitend volgens deze instructies. Onjuiste montage kan gevaren creëren.
2. Draag tijdens de montage stevige ANSI-goedgekeurde werkhandschoenen.
3. Zorg ervoor dat de verzamelplaats schoon en goed verlicht is.
4. Houd omstanders uit de buurt tijdens de montage.
5. Niet monteren als u moe bent of onder invloed van alcohol,

drugs of medicijnen.

6. Het draagvermogen en andere productcapaciteiten zijn van toepassing op de juiste en Enkel volledig gemonteerd product.

7. Monteer op een vlak, egaal, hard en glad oppervlak dat bestand is tegen het veilig ondersteunen van een volledig geladen kist.













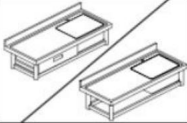





Gebruik voorzorgsmaatregelen







OM ERNSTIG LETSEL EN DE DOOD DOOR KANTELEN TE VOORKOMEN:

1. NIET OP DIT ITEM ZITTEN, STAAN OF KLIMMEN.
2. Dit product is geen speelgoed of speelgoedkist. Laat kinderen er niet mee spelen. met of in de buurt van dit item.
3. Controleer het product voor elk gebruik. Gebruik het niet als er onderdelen loszitten of beschadigd zijn.

Onderdelenlijst

LET OP: Sommige bevestigingsmiddelen kunnen reserveonderdelen bevatten. Let hier goed op tijdens het gebruik. installatie.

Parts No.	Picture	Qty	Parts No.	Picture	Qty
(A)		1PC	(J)	 transparent	1PC
(B)		1PC	(K)		1PC
(C)		4PCS	(L)		1PC
(D)		2PCS	(M)		1PC
(E)		2PCS	(N)		1PC
Let op: Wielen D en E zijn alleen compatibel met modellen SS100-3 en SS1200-4.			(O)	 White	1PC
(G)		elke stijl 2PCS	(P)	 Dark blue	1PC
(H)		1PC	(Q)	 Black	1PC
(I)		1PC	(R)		1PC

Parts No.	Picture	Qty	Parts No.	Picture	Qty
Ⓢ		1PC	Ⓧ		1PC
Ⓣ		4PCS			
Ⓤ		4PCS			
Ⓥ		4PCS			
Ⓦ		4PCS			

Montage­stap­pen

1



(A) x1pc



(C) x4pcs

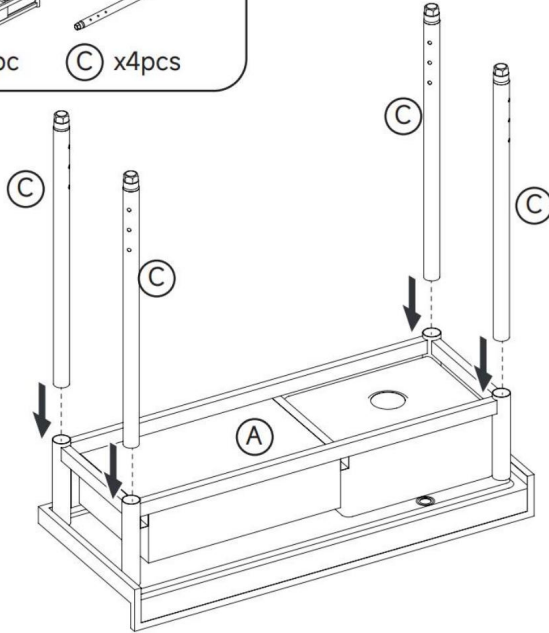

2



(B) x1pc



(T) x4pcs



(U) x4pcs



(V) x4pcs



(W) x4pcs

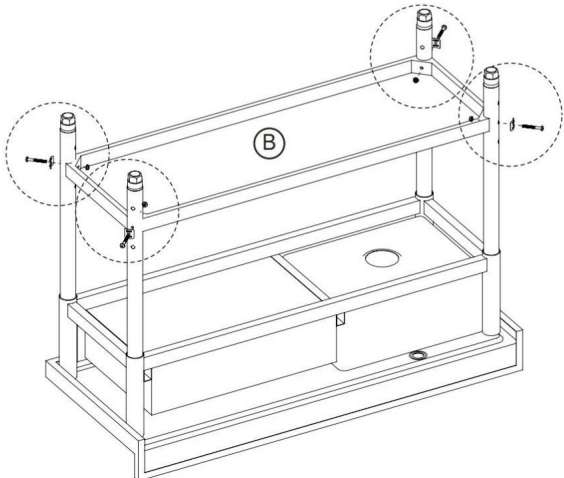
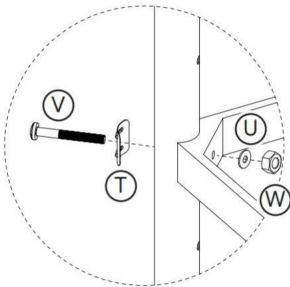

3



(D) x2pcs



(E) x2pcs

OR



(F) x4pcs

Rotate the wheels or adjust the feet as needed

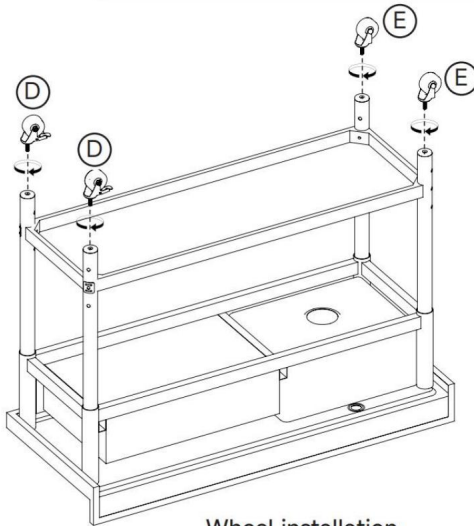

Wheel installation

OR

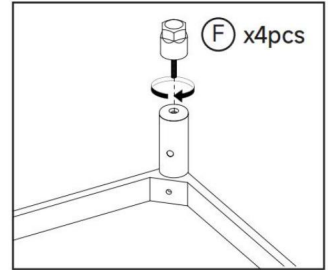

Adjustable foot installation

OPMERKING: Deze installatiestap is alleen van toepassing op de modellen SS100-3 en SS1200-4. Andere modellen hebben geen wielen.

4

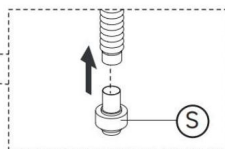
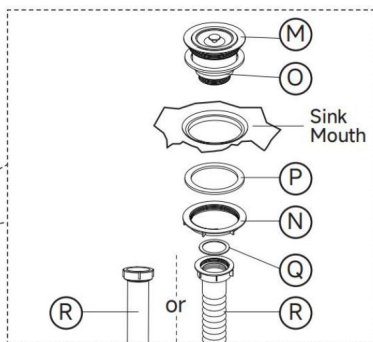
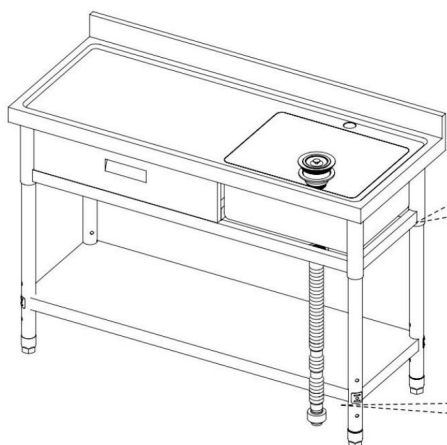
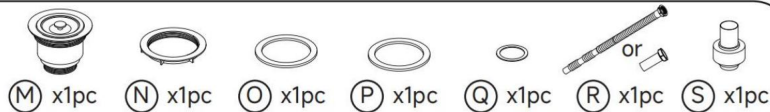

OPMERKING: De flexibele slang R en de starre buis R van de afvoerbuis kunnen selectief worden geïnstalleerd op basis van het gebruiksscenario van de gebruiker. Normaal gesproken wordt de flexibele slang bij het installeren rechtstreeks aangesloten op de grondafvoer van de tuin. (Figuur A) Het installeren van vaste leidingen is over het algemeen geschikt voor het aansluiten van de riolering in een huis. (Figuur B)

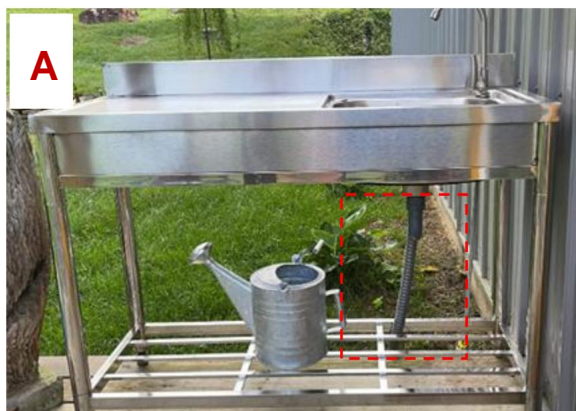

B



5



(G) x2pcs



(H) x1pc



(I) x1pc



(J) x1pc



(K) x1pc



(L) x1pc

5-1

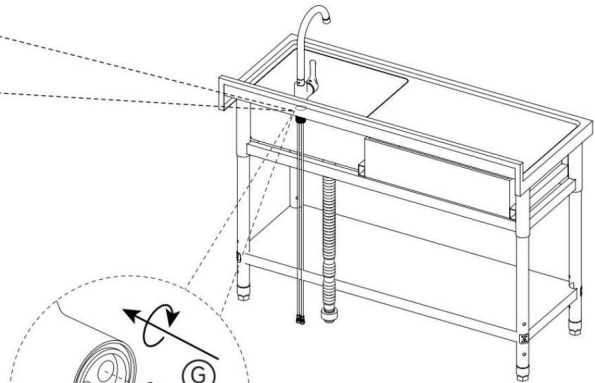
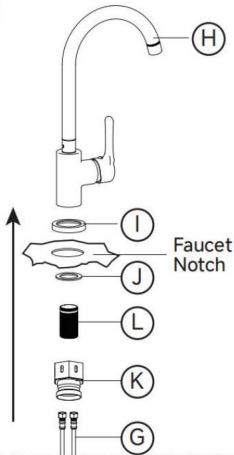

5-2

Align the red pattern tube (G) to the red port.
Align the blue pattern tube (G) to the blue port.

6

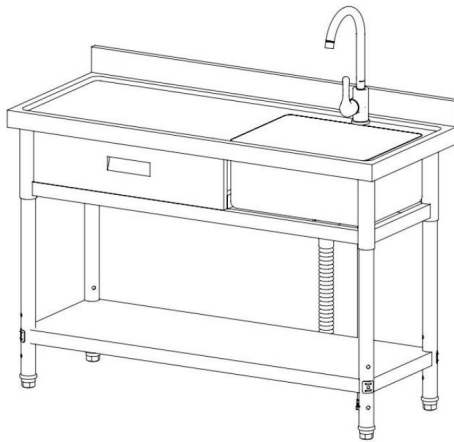

Completed

ZORG EN ONDERHOUD

Schoonmaak:

Zorg ervoor dat u na gebruik het water op het afdruiplateau en de gootsteen goed afdroogt met een lap.

Als er tegelijkertijd roestvlekken of moeilijk te behandelen vlekken op het oppervlak zitten, veeg deze dan af met het meegeleverde schuursponsje

Kennisgeving:

Controleer regelmatig of de schroeven van het product loszitten en draai ze regelmatig vast.

Fabrikant: Shanghaimuxinmuyeyouxiangongsi **Adres:**

Shuangchenglu 803nong11hao1602A-1609shi, baoshanqu, shanghai 200000 CN.

Geïmporteerd naar AUS: SIHAO PTY LTD. 1 ROKEVA STREETEASTWOOD NSW
2122 Australië

Geïmporteerd naar de VS: Sanven Technology Ltd. Suite 250, 9166 Anaheim Place,
Rancho Cucamonga, CA 91730



YH CONSULTING LIMITED. T.a.v. YH Consulting Limited
Kantoor 147, Centurion House, London Road, Staines-
upon-Thames, Surrey, TW18 4AX



E-CrossStu GmbH
Mainzer Landstr.69,
60329 Frankfurt am Main.



VEVOR

Affordable. Reliable. Home Improvement.

Fristående diskho i rostfritt stål

MODELL: SS100-1; SS1200-1; SS100-2; SS100-3;
SS1200-3; SS1200-4; SS100-4; SS1200-5

VEVOR

Affordable. Reliable. Home Improvement.

Fristående rostfritt stål Stålvask y

MODELL: SS100-1; SS1200-1; SS100-2; SS1200-3;



MODELL: SS100-3; SS1200-4; **MODELL:** SS100-4; SS1200-5



Obs: Produktbilden är endast för referens, de faktiska detaljerna ska gälla.

Detta är originalinstruktionerna, vänligen läs alla instruktioner noggrant innan du använder produkten. VEVOR förbehåller sig en tydlig tolkning av vår användarmanual. Produktens utseende ska vara beroende av den produkt du mottagit. Vi ber om ursäkt för att vi inte kommer att informera dig igen om det finns några teknik- eller programuppdateringar för vår produkt.

Tack så mycket för att du valde den här produkten

Läs alla instruktioner innan du använder den. Informationen kommer att hjälpa dig uppnå bästa möjliga resultat.

Driftsäkerhet

Förvara denna manual på en plats där den är lätt att kontrollera och förvara den ordentligt.

Bruksanvisningen anger tydligt hur utrustningen används säkert och korrekt, för att förhindra skada eller egendomsförlust för dig eller andra.

SÄKERHET

	Läs instruktionsboken.		Varning / Försiktighet.
	Anmärkning / Anmärkning.		bär handskar



WARNING! Läs och förstå alla instruktioner innan du använder detta Fristående diskho i rostfritt stål. Operatören måste följa grundläggande försiktighetsåtgärder för att minska risken för personskada och/eller skador på utrustning. Spara denna manual för säkerhetsvarningar, försiktighetsåtgärder, drift eller inspektions- och underhållsinstruktioner.

Bekanta dig med riskmeddelandena i den här handboken. Ett meddelande finns en varning om att det finns risk för egendomsskada, personskador eller dödsfall om vissa instruktionerna följs inte.

WARNING! Låt INTE den komfort eller förtrogenhet med produkten (från upprepad användning) ersätter strikt efterlevnad av verktygets säkerhetsregler. Om du Om du använder detta verktyg på ett osäkert eller felaktigt sätt kan du drabbas av allvarliga personskador. skada.



Monteringsförsiktighetsåtgärder

1. Montera endast enligt dessa instruktioner. Felaktig montering kan skapa faror.
2. Använd ANSI-godkända, kraftiga arbetshandskar under monteringen.
3. Håll samlingsområdet rent och väl upplyst.
4. Håll åskådare borta från området under monteringen.
5. Montera inte när du är trött eller påverkad av alkohol,

droger eller medicinering.

6. Viktkapacitet och annan produktkapacitet gäller korrekt och endast helt monterad produkt.

7. Montera på en plan, jämn, hård och slät yta som klarar säkert stöd för en fullt lastad kista.













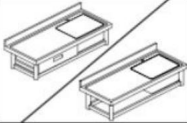





Använd försiktighetsåtgärder







FÖR ATT FÖRHINDRA ALLVARLIGA SKADOR OCH DÖDSFALL GENOM TIPPNING:

1. SITTA, STÅ ELLER KLÄTTRA INTE PÅ DENNA FÖRENING.
2. Denna produkt är inte en leksak eller en leksakslåda. Låt inte barn leka med eller nära detta föremål.
3. Kontrollera före varje användning; använd inte om delar är lösa eller skadade.

Dellista

OBS: Vissa fästelement kan ha reservdelar. Var uppmärksam under installation.

Parts No.	Picture	Qty	Parts No.	Picture	Qty
(A)		1PC	(J)	 transparent	1PC
(B)		1PC	(K)		1PC
(C)		4PCS	(L)		1PC
(D)		2PCS	(M)		1PC
(E)		2PCS	(N)		1PC
Obs: Hjulen D och E är endast kompatibel med modeller SS100-3 och SS1200-4.			(O)	 White	1PC
(G)		varje stil 2PCS	(P)	 Dark blue	1PC
(H)		1PC	(Q)	 Black	1PC
(I)		1PC	(R)		1PC

Parts No.	Picture	Qty	Parts No.	Picture	Qty
Ⓢ		1PC	Ⓧ		1PC
Ⓣ		4PCS			
Ⓤ		4PCS			
Ⓥ		4PCS			
Ⓦ		4PCS			

Monteringssteg

1



(A) x1pc



(C) x4pcs

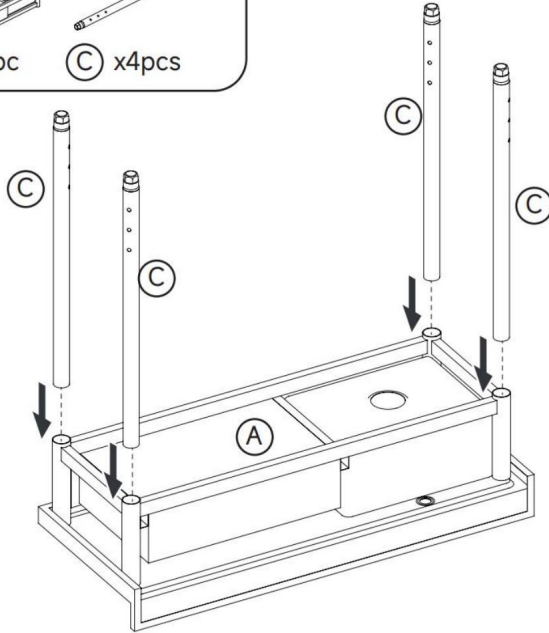

2

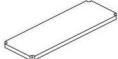

(B) x1pc



(T) x4pcs



(U) x4pcs



(V) x4pcs



(W) x4pcs

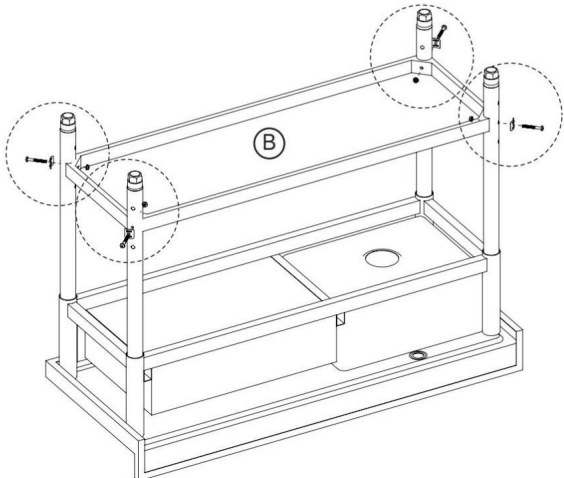
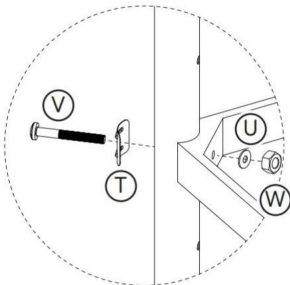

3



D x2pcs



E x2pcs

OR



F x4pcs

Rotate the wheels or adjust the feet as needed

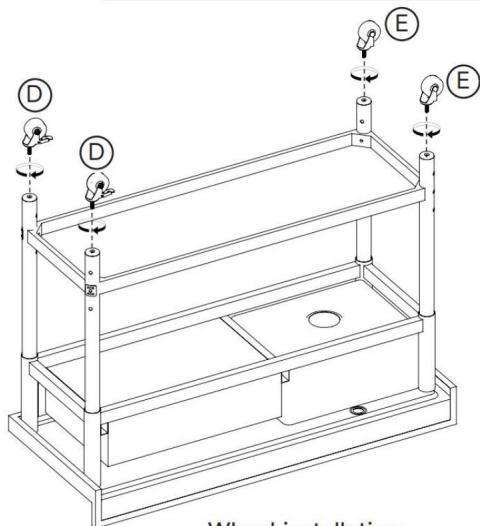

Wheel installation

OR

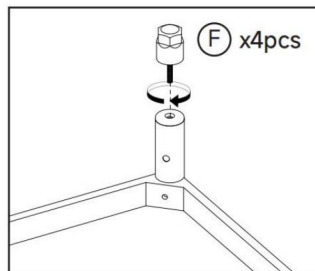

Adjustable foot installation

OBS! Detta installationssteg gäller endast modellerna SS100-3 och SS1200-4. Andra modeller har inte hjul.

4

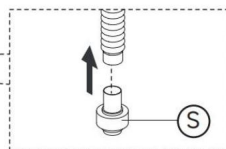
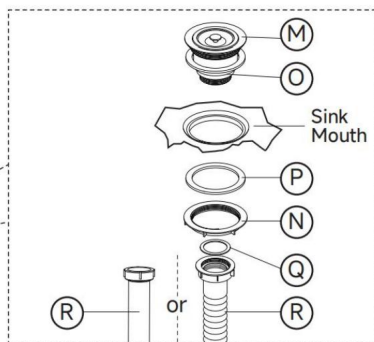
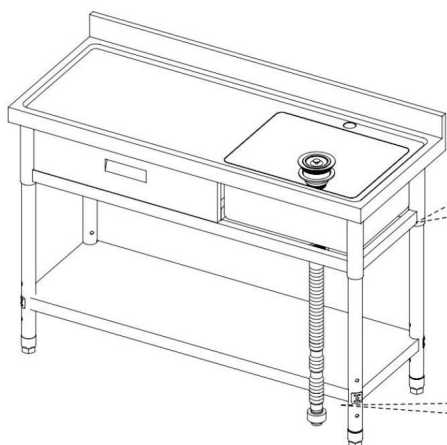
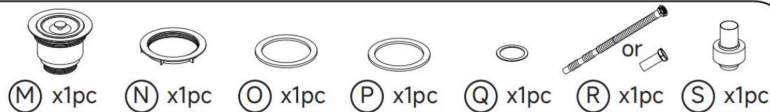

OBS: Den flexibla slangen R och det styva röret R i dräneringsröret kan installeras selektivt enligt användarens användningsscenario.

Generellt sett ansluts den flexibla slangen direkt till trädgårdens markavlopp när den installeras. (Figur A)

Installation av hårda rör är generellt lämpligt för anslutning av avloppsrör i ett hushåll. (Figur B)

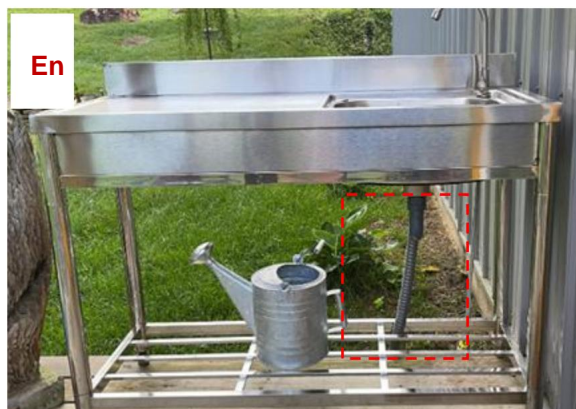

B



5



(G) x2pcs



(H) x1pc



(I) x1pc



(J) x1pc



(K) x1pc



(L) x1pc

5-1

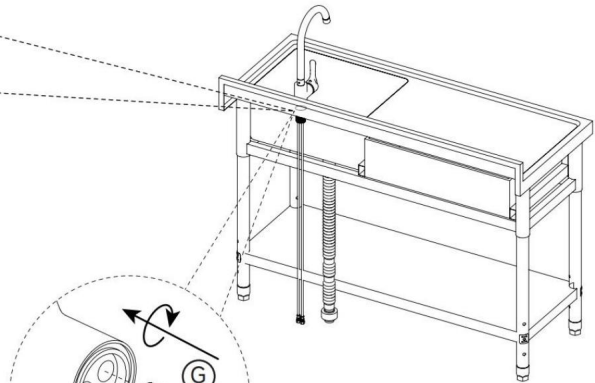
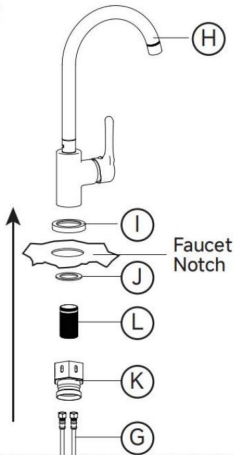

5-2

Align the red pattern tube (G) to the red port.
Align the blue pattern tube (G) to the blue port.

6

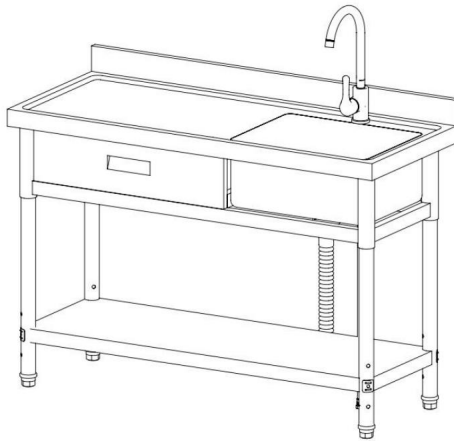

Completed

SKÖTSEL OCH UNDERHÅLL

Rengöring:

Efter användning, se till att torka vattnet på avrinningsplattan och diskhon med en trasa.

Samtidigt, om det finns rostfläckar eller svårbehandlade märken på ytan, torka av dem med den kostnadsfria skursvampen.

Varsel:

Kontrollera regelbundet om produktens skruvar är lösa och dra åt dem regelbundet.

Tillverkare: Shanghaimuxinmuyeyouxiangongsi **Adress:**

Shuangchenglu 803nong11hao1602A-1609shi, baoshanqu, shanghai 200000 CN.

Importerad till Australien: SIHAO PTY LTD. 1 ROKEVA STREETEASTWOOD NSW
2122 Australien

Importerad till USA: Sanven Technology Ltd. Suite 250, 9166 Anaheim Place,
Rancho Cucamonga, CA 91730

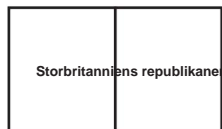

YH CONSULTING LIMITED. C/O YH Consulting Limited
Kontor 147, Centurion House, London Road, Staines-
upon-Thames, Surrey, TW18 4AX



E-CrossStu GmbH
Mainzer Landstr.69,
60329 Frankfurt am Main.

