

VEVOR[®]

TOUGH TOOLS, HALF PRICE

Technical Support and E-Warranty Certificate www.vevor.com/support

CORDLESS PRESSURE WASHER

MODEL:XS-003/XS-00B

We continue to be committed to provide you tools with competitive price.

"Save Half", "Half Price" or any other similar expressions used by us only represents an estimate of savings you might benefit from buying certain tools with us compared to the major top brands and does not necessarily mean to cover all categories of tools offered by us. You are kindly reminded to verify carefully when you are placing an order with us if you are actually saving half in comparison with the top major brands.

VEVOR®

TOUGH TOOLS, HALF PRICE

CORDLESS
WASHER

PRESSURE

MODEL:XS-003/XS-00B

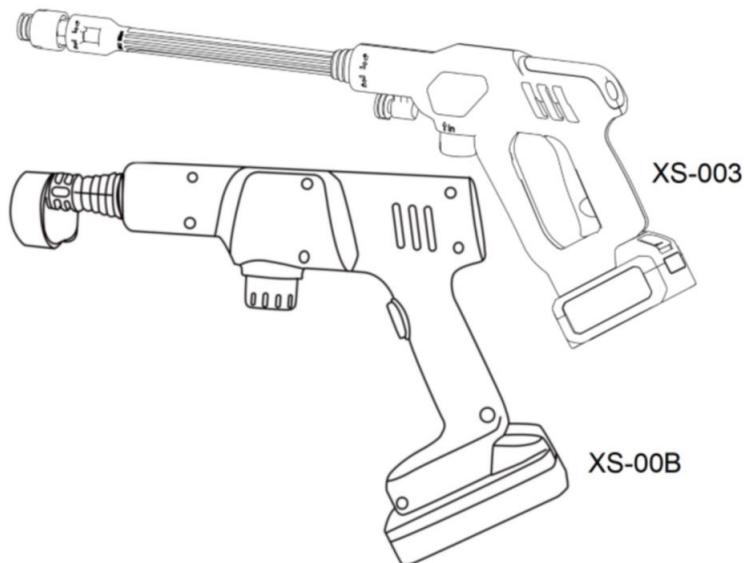

NEED HELP? CONTACT US!

Have product questions? Need technical support? Please feel free to contact us:

Technical Support and E-Warranty Certificate
www.vevor.com/support

This is the original instruction, please read all manual instructions carefully before operating. VEVOR reserves a clear interpretation of our user manual. The appearance of the product shall be subject to the product you received. Please forgive us that we won't inform you again if there are any technology or software updates on our product.

PRODUCT PAREMETERS

Model		XS-003	XS-00B
MAX Working Pressure		652PSI	652PSI
MAX Flow Rate		4L/min	3.5L/min
Rated Power		250W	200W
Usable Laundry Detergent		Neutral Detergent	
Battery	Battery Type	Lithium Battery	
	Voltage	DC21V	
	Capacity	4000mAh	
Charger	Input Voltage	AC 100-240V 50/60 Hz	
	Output Voltage	DC21V 0.75A	
	Charging Time	5 hours	
Min.Suction Height		3M	
FCC statement:			
<p>This device complies with Part 15 of the FCC Rules. Operation is subject to the following two conditions:(1)This device may not cause harmful interference, and (2)this device must accept any interference received, including interference that may cause undesired operation.</p>			

PRODUCT INTRODUCTION

Based on the principle of user experience first, quality first, the pursuit of convenience, fast, portable, energy-saving and other superior characteristics, for the majority of car-loving people and home cleaning and washing and customized development of a product, At the same time, the product is not limited by power supply, with strong and stable battery.Product can be carried with you, multi-scene application, anytime, anywhere for you to save time, save cleaning costs, high efficiency to bring DIY washing fun and quality experience.

PACKING LIST

XS-003



1. Fuselage Shell
2. Multi-Functional Six-In-One Sprinkler Head
3. Nylon Extension Rod
4. Water Inlet Connector
5. Filter Screen
6. Universal Sprinkler Head
7. Coke Bottle Connector

8. Foam Pot
9. Rotate The Gun Head
10. 6m Water Inlet Pipe
11. 4.0Ah Battery
12. Charger
13. 11 Liters Of Water Bucket
14. Carbon Fiber Storage Bag

XS-00B



- | | |
|---|------------------------------|
| 1. Fuselage Shell | 10. 6M Water Inlet Pipe |
| 2. Multi-Functional Six-In-One Sprinkler Head | 11. Foam Pot |
| 3. Charger | 12. Rotate The Gun Head |
| 4. 4.0Ah Battery | 13. Screen Filter |
| 5. Coke Bottle Connector | 14. Water Inlet Connector |
| 6. 0 Degree Sprinkler | 15. Universal Sprinkler Head |
| 7. 40 Degree Sprinkler Head | 16. Carbon Fiber Storage Bag |
| 8. Stainless Steel Extension Bar | 17. 11L Bucket |
| 9. Nylon Extension Rod | 18. Gloves |

SAFETY & WARNING

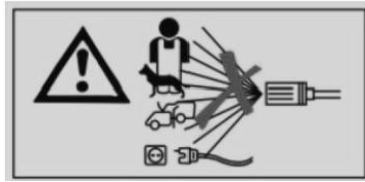

When using electrical appliances, base safety precautions should always be followed including the following:



READ ALL INSTRUCTIONS

1. Use shall not direct water flow to the crowd and live components.
2. Ensure that children are not exposed to the range area when the battery pack is charged.
3. Battery pack and charger are hit by drop collision or wet visible state should be stopped immediately!
4. Must charge the battery pack in the presence of someone!
5. Chargers must choose the original factory (without authorization or the original factory's proposal to prohibit the use of other charging accessories or charging methods.
6. Charging environment is prohibited in high temperature or unattended or accessible locations for children.
7. Unscheduled product inspection, charger, battery pack, car washing machine mainframe, if abnormal or damaged or malfunction do not modify or disassemble.
8. This appliance can be used by children aged from 8 years and above and persons with reduced physical, sensory or mental capabilities or lack of experience and knowledge if they have been given supervision or instruction concerning use of the appliance in a safe way and understand the hazards involved. Children shall not play with the appliance. Cleaning and user maintenance shall not be made by children without supervision.

Safety precautions for battery pack:

1. Do not disassemble, open or shred battery sets.
2. It is forbidden to expose battery pack to heat source or high temperature

sunlight.

3. Do not short circuit the battery pack (positive and negative connection), do not put the battery pack in the box drawer to avoid short circuit between them or by other metal items.
4. Do not remove the battery or battery pack from the original package before use
5. Prohibit battery packs from falling or mechanical impact.
6. Once the battery leaks, do not touch the leaking liquid directly into the eyes or skin. In case of accidental contact, rinse the contact area immediately with plenty of water and consult a doctor in time.
7. Shall not use non-original charger and battery pack. (Causes machine malfunction or accidental personal injury)
8. Pay attention to the positive and negative signs on the battery pack to ensure proper connection.
9. Keep the machine and battery pack group away from children.
10. Ensure clean and dry battery pack. (If dust or residual water should be immediately wiped with clean cloth or natural air drying, do not use hair dryer or hot air gun drying)
11. The battery pack must be charged before use, using the correct charger and referring to the manufacturer's operating instructions or the original equipment instructions
12. Not using the machine, do not charge the battery pack for a long time, pay attention to the green light is full of electricity, red light is in charge.
13. In case of long-term storage of unused machines, battery packs should be subjected to several charge/discharge cycles to achieve optimal performance.
14. The use of battery pack groups at room temperature (20°C +5°C) performs best.
15. This product is only suitable for home doors and windows, courtyard, vehicles, garden cleaning operations, not for commercial operations or main frequency flow operations, not higher than the battery group use time or high frequency forced use.
16. Remove the battery pack whenever possible when not using the machine, disconnect from the mainframe and place it in a dry place not accessible to children.

17. Battery pack group due to other human damage or collision, high temperature damage, reasonable treatment and recovery, do not discard the contaminated environment.

SAVE THESE INSTRUCTIONS

INSTALLATION GUIDELINE

Open the box to check whether the machine is in good condition and whether it is the corresponding model for purchase. Then take out the attachment one by one and place it in the plane. Install and use according to the operation procedure!

Note: If there is water in the machine, please don't get upset. The product is not second-hand. In order to ensure that you receive a product that is in perfect condition, each of our products undergoes a pumping test before leaving the factory.



1.Align the groove and clip the 6-inch nozzle into the washer



2.Press the locking nozzle into the groove and twist it to achieve self spraying



3. If angle adjustable nozzle or foam tank is to be used, the connection method is the same as step 01-02.

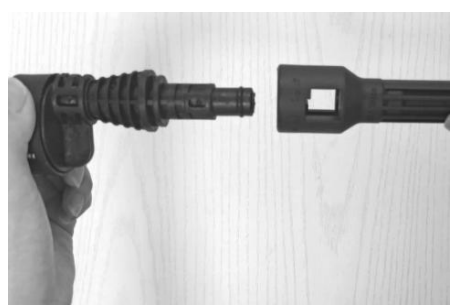

4. Press the nozzle into the groove and twist it to achieve self-locking

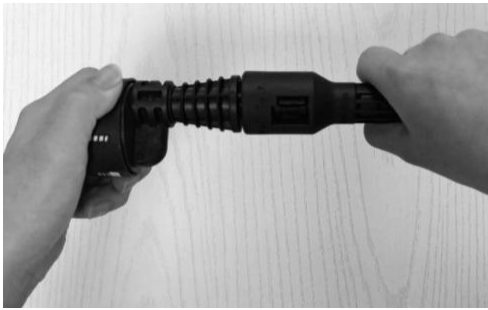

5. Press the nozzle into the groove and twist it to achieve self-locking.

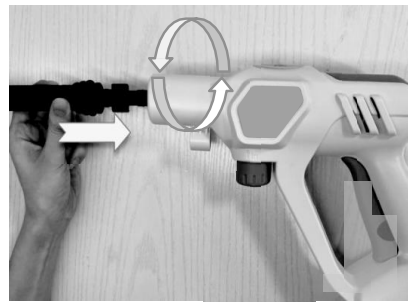

6. The extension rod is applicable to all nozzles, including foam tank joints, and the connection method is the same as that in step 04-05.



7. Align the groove and clip the foam can into the extension joint.



8. Press the foam tank connector into the groove in the hose and twist it for self-locking.



9. The foam volume can be adjusted by turning the button on the adapter.



10. Connect the quick connector to the pressure washer. (Loosen the lock nut and engage upwards to remove the pipeline)



11. Inject water into the bucket and immerse the filter holder in water.

12. If you choose a six-in-1 nozzle, you can twist the nozzle to change the spraying mode.

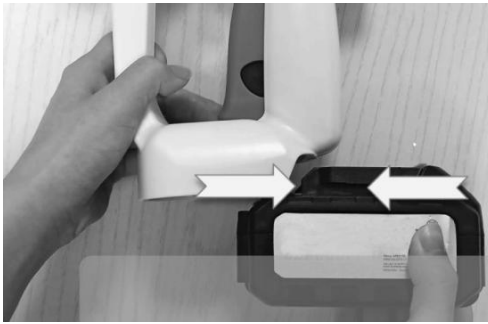

13. Connect the battery to the cleaning machine.



14. Press the black safety lock button to disconnect the cleaning machine.



15. Press and hold the start switch to operate.



16. Press this button to switch between three gear modes. (TIPS: XS-002 don't have this function.)



17. After completing the work, press the safety lock button back. (TIPS: XS-002



18. Press the button to remove the battery.

and XS-00B don't have this function.)



19. Press the red button to display the battery level.



20. Plug in the power to charge.

TROUBLE-SHOOTING

Frequently Asked Questions	Cause analysis	Solutions
Normal operation of machine without water suction	1. Machine is too high above water	Down to below 1.5 m ground
	2. Filter screen foreign body clogging	Remove filter and clean
	3. Failure of connection of Intake pipe to machine or rupture of intake pipe	Check and replace water pipes, please contact customer service
	4. Intake pipe bending clamp	Straighten out intake pipes and reconnect
	5. The pump froze because of the cold weather	Restart after thawing

Sudden increase in effluent pressure or abnormal water type	The head of the water gun was blocked by a foreign body	Use a needle to clear the nozzle or replace the new gun head
Machine does not start	1. Battery pack not Installed	reinstallation
	2. Battery pack is dead	Charge or replace new battery pack
	3. Battery pack is broken	Replacement of battery pack
Battery pack not charged	Charger mismatch or broken	Replacement of matching charger
Machine pressure discontinuity	Air in 1.pump	Check that joints and pipes are in good condition
	2. Machine in low voltage mode	Normal at low pressure, no treatment required
Machine automatic stop	1. Battery pack is dead	Charge or replace battery pack
	2. Gun head blocked, current protection	To clear or replace the head
Leakage Inside machine	Chemical acid source or assembly cause	Avoid using chemical sources

REPAIR AND MAINTENANCE

1. Each time before use, please check if the machine and parts are damaged, if

there is damage stop using the machine, contact the supplier or manufacturer to replace the parts.

2. Intake pipes and filters must be cleaned after each use and bags should be kept to avoid oxidation for easy use in the future.

3. After the use of the mainframe, the empty machine should run for a few seconds to drain the residual water from the machine, avoid oxidation dirt and weather ice, and store in a dry cool place.

4. Waste disposal: for damaged accessories and packaging materials must be classified and recovered, do a good job of marking.

5. Do not store in the trunk of the car high temperature weather to avoid fire caused by high temperature. Warning: do not use chemical acid and muddy water, must use clean, impurity-free clear water.

CORRECT DISPOSAL



This product is subject to the provision of European Directive 2012/19/EC. The symbol showing a wheeled bin crossed through indicates that the product requires separate refuse collection in the European Union. This applies to the product and all accessories marked with this symbol. Products marked as such may not be discarded with normal domestic waste, but must be taken to a collection point for recycling electrical and electronic devices

BATTERY DISPOSAL



Li-Ion battery This product has been marked with a symbol relating to 'separate collection' for all battery packs and battery pack. It will then be recycled or dismantled in order to reduce the impact on the environment. Battery packs can be hazardous for the environment and for human health since they contain hazardous substances

Manufacturer: Shanghaimuxinmuyeyouxiangongsi

Address: Shuangchenglu 803nong11hao1602A-1609shi, baoshanqu, shanghai 200000 CN.

Imported to USA: Sanven Technology Ltd., Suite 250, 9166 Anaheim Place, Rancho Cucamonga, CA 91730



E-CrossStu GmbH
Mainzer Landstr.69, 60329 Frankfurt am Main.



YH CONSULTING LIMITED.
C/O YH Consulting Limited Office 147, Centurion House, London Road, Staines-upon-Thames, Surrey, TW18 4AX

VEVOR[®]

TOUGH TOOLS, HALF PRICE

Technical Support and E-Warranty Certificate

www.vevor.com/support