

VEVOR

Affordable. Reliable. Home Improvement.

FLOOR JACK

MODEL:VL-80225

VEVOR Support Center



MODEL:VL-80225

VEVOR

Affordable. Reliable. Home Improvement.

FLOOR JACK

MODEL:VL-80225



This is the original instruction, please read all manual instructions carefully before operating. VEVOR reserves a clear interpretation of our user manual. The appearance of the product shall be subject to the product you received. Please forgive us that we won't inform you again if there are any technology or software updates on our product.



Warning-To reduce the risk of injury, user must read instructions manual carefully.

DESCRIPTION OF THE SYMBOLS



WARNING: The jack must be used only on hard level surfaces and be free to roll during lifting and lowering. Do not get under a vehicle that is supported only by a trolley jack-use support stands.



CAUTION: Carefully read instructions and procedures for safe operations.

INSPECTIONS

1. Before Each Use

Visual inspection should be made before each use of the garage jack for abnormal conditions such as cracked welds, leaks and damaged, loose, or missing parts.

2. After Each Use

The garage jack should be inspected immediately if the lift is believed to have been subjected to an abnormal load or shock. It is recommended that inspection be made by manufacturer's or supplier's authorised repair facility.

RECOMMENDATION FOR SAFE USAGE OF THE JACK

1. The jack should be used on a hard level surface and be free to roll during lifting and lowering.
2. The unlifted wheels of the vehicle should be chocked.
3. The load should be centrally located on the head cap.
4. No person should remain in a vehicle that is being lifted.
5. The jack should be used for lifting and lowering only. The raised vehicle should be supported on vehicle support stands.
6. No person should get their body under a vehicle that is supported only by a hydraulic trolley jack.
7. The vehicle manufacturer owner's manual should be consulted prior to lifting the vehicle.
8. Make sure that the lift point is stable and properly centered on the head cap.
9. Do not move or dolly the vehicle while on the jack.

CAUTION BEFORE USING

Due to shipment and/or handling air can be trapped in the hydraulic system, which can interfere with the jacks' lifting. To release air from the hydraulic system:

1. Open release valve by turning the jack handle counterclockwise.
2. Remove the oil filler plug from the cylinder.
3. Rapidly pump jack handle through several full strokes.
4. Replace the oil filler plug in the cylinder.



WARNING

1. The unlifted wheels of the vehicle should be chocked.
2. The load should be centrally located on the head cap.
3. No person should remain in a vehicle that is being lifted.
4. The vehicle manufacturer owner's manual should be consulted prior to lifting the vehicle.
5. The hydraulic trolley jack should be used for lifting and lowering only. And it can not be used as a support tool.

SET UP - BEFORE USE



WARNING: Read the ENTIRE IMPORTANT SAFETY INFORMATION section at the beginning of this manual including all text under subheadings therein before setting up or using this product.

Part List			
No.	Name	Picture	QTY.
1	Jack		1
2	Lower Handle		1
3	Upper Handle		1

ATTACHING THE HANDLE

1. Attach the Upper Handle to the Lower Handle.
2. Loosen the Set Screw and insert the assembled Handle into the Handle Socket.
3. Tighten the Set Screw.

FUNCTIONS (Take WD-B-03000-B00-0 as an example)

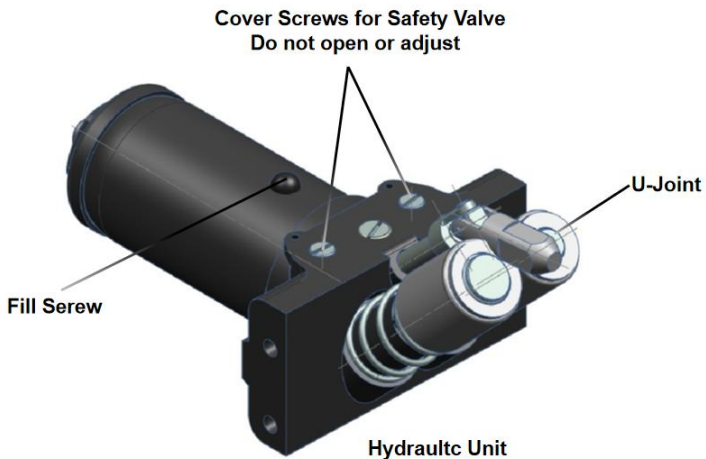

OPERATING INSTRUCTIONS



WARNING: Read the ENTIRE IMPORTANT SAFETY INFORMATION section at the beginning of this manual including all text under subheadings therein before setting up or using this product.

AIR REMOVAL

BEFORE EACH USE OR IF JACK'S PERFORMANCE DECREASES

Check for excessive air and proper hydraulic fluid level in Jack. If Jack appears not to be working properly, it may be necessary to purge its hydraulic system of excessive air as follows:

1. Loosen the Fill Screw.
2. Check fluid level and, if necessary, top off by adding Hydraulic Fluid.
3. Twist the Handle clockwise to the tightest position to close the Valve, then pump the Handle several times quickly.
4. **IMPORTANT:** After the air is removed, test the Jack for proper operation prior to its actual use.
5. If the air is removed and the Jack does not appear to be working properly, do not use it until it is repaired by a qualified service technician.
- 6.

ADDING HYDRAULIC FLUID

1. Remove the Fill Screw. Do not remove or loosen Safety Valve Cover Screws.
2. Add high grade hydraulic fluid (sold separately) slowly until the fluid reaches 1/4" below the top of the Fill Port.

Note: Do not touch the handle when adding hydraulic fluid.

3. Tighten the Fill Screw.

LIFTING



WARNING: Park vehicle on a flat, level, solid, surface safely away from oncoming traffic. Turn off the vehicle's engine. Place the vehicle's transmission in "PARK" (if automatic) or in its lowest gear (if manual). Set the vehicle's emergency brake. Then chock the wheels that are not being lifted.

1. Slowly twist the Handle counterclockwise to lower the Jack. Once the Jack is fully lowered, twist the Handle clockwise to the tightest position to close the Valve.

2. Carefully position the Jack's Saddle under the vehicle manufacturer's recommended lifting point.
(See the vehicle manufacturer's owner's manual for the location of the frame lifting point.)
3. Pump the Handle until the top of the Saddle has nearly reached the vehicle's lifting point. Position the Saddle directly under the vehicle's lifting point.
4. To lift the vehicle, pump the Handle. Use smooth, full strokes.
5. Select matching jack stands (sold separately) of appropriate capacity. Set the jack stands to the same height according to the manufacturer's instructions, making sure they lock securely into position.
6. Position the jack stands' saddles under the vehicle manufacturer's recommended support points.
WARNING! Ensure that the vehicle support points are fully seated in the saddles of both jack stands. Use a matched pair of jack stands per vehicle to support one end only.
7. Slowly twist the Handle counterclockwise to lower the vehicle onto the jack stands' saddles.
8. Once the vehicle is fully seated on the jack stands, continue slowly lowering the Jack until it is completely lowered.
9. Remove the Jack and store it safely out of the way.

LOWERING

1. Carefully remove all tools, parts, etc., from under the vehicle.
2. Position the Jack's Saddle under the lifting point. Turn the Handle firmly clockwise and raise the vehicle high enough to clear the jack stands.
3. Carefully remove the jack stands.
4. Slowly turn the Handle counterclockwise to lower the vehicle onto the ground.
5. Lower the Jack completely. Store the Jack indoors out of children's reach.

MAINTENANCE AND SERVICING



WARNING: Procedures not specifically explained in this manual must be performed only by a qualified technician.



WARNING: TO PREVENT SERIOUS INJURY FROM TOOL FAILURE: Do not use damaged equipment. If abnormal noise or vibration occurs, have the problem corrected before further use

CLEANING, MAINTENANCE AND LUBRICATION

1. **BEFORE EACH USE**, inspect the general condition of the Jack. Check for:
 - Loose hardware
 - Misalignment or binding of moving parts
 - Cracked or broken parts
 - Any condition that may affect its safe operation
2. **BEFORE EACH USE**, thoroughly test the Jack for proper operation prior to its actual use. If the Jack appears not to be working properly, follow **AIR REMOVAL** instructions.
3. **AT LEAST ONCE EVERY THREE YEARS**, change the hydraulic fluid:
 - With the Jack fully lowered, remove the Fill Screw.
 - Tip the Jack over to allow the old hydraulic fluid to drain out completely. Dispose of the old hydraulic fluid in accordance with local regulations.
 - With the Jack upright, completely fill the Hydraulic Unit with high grade hydraulic fluid until the fluid is 1/4" below the top of the Fill Port.
 - Turn the Handle counterclockwise to open the Release Valve.
 - Pump the Handle up and down quickly several times to purge air from the system.
 - Recheck fluid level and re-fill as needed.
 - Replace the Fill Screw.
4. **AFTER EACH USE**, wipe with a clean cloth. Store the Jack indoors out of children's reach.

TROUBLE SHOOTING



WARNING
TO PREVENT SERIOUS INJURY:

Use caution when troubleshooting a malfunctioning jack. Stay well clear of the supported load. Completely resolve all problems before use. If the solutions presented in the Troubleshooting guide do not solve the problem, have a qualified

technician inspect and repair the jack before use.

After the jack is repaired:

Test it carefully without a load by raising and lowering it fully, checking for proper operation, BEFORE RETURNING THE JACK TO OPERATION.

DO NOT USE A DAMAGED OR MALFUNCTIONING JACK

POSSIBLE SYMPTOMS						PROBABLE SOLUTION (Make certain that the Jack is not supporting a load while attempting a solution.)
Jack will not lift at its weight capacity	Saddle lowers under load	Pump stroke feels spongy	Saddle will not lift all the way	Handle moves up when jack is under load	Fluid leaking from the fill plug	
X	X					Check that the Release Valve is fully closed. The jack needs to expel air.
X	X			X		Valves may be blocked and may not close fully. To flush the valves: 1. Lower the saddle and securely close the release valve. 2. Manually lift the saddle several inches. 3. Open the release valve by turning the Handle counterclockwise. And force the saddle down as quickly as possible.
X		X	X			Jack may be low on hydraulic fluid. Check fluid level and refill if needed.

						The jack needs to expel air.
					X	The unit may have too much hydraulic fluid inside. Check fluid level and adjust if needed.

PLEASE READ THE FOLLOWING CAREFULLY

The manufacturer and/or distributor has provided the parts list and assembly diagram in this manual as a reference tool only. Neither the manufacturer nor distributor makes any representation or warranty of any kind to the buyer that he or she is qualified to make any repairs to the product or that he or she is qualified to replace any parts of the product. In fact, the manufacturer and/or distributor expressly states that all repairs and parts replacements should be undertaken by certified and licensed technicians and not by the buyer. The buyer assumes all risk and liability arising out of his or her repairs to the original product or replacement parts thereto or arising out of his or her installation of replacement parts thereto.

NOTE: Some parts are listed and shown for illustration purposes only, and are not available individually as replacement parts.

TECHNICAL SPECIFICATION

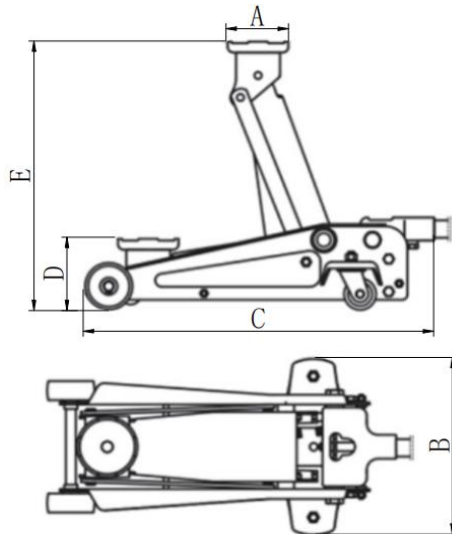

Model	VL-80225
Parameter	
Lift Weight Capacity	2.5 Tons
Load Bearing Method	Hydraulic Double Cylinder
Tray Diameter A (mm)	99mm
Width B (mm)	305mm
Length C (mm)	685mm
Min Height D (mm)	95mm
Max Height E (mm)	475mm
Material	Steel

Manufacturer: Shanghaimuxinmuyeyouxiangongsi

Address: Shuangchenglu 803nong11hao1602A-1609shi, baoshanqu, shanghai 200000 CN.

Imported to AUS: SIHAO PTY LTD. 1 ROKEVA STREETEASTWOOD NSW 2122 Australia

Imported to USA: Sanven Technology Ltd. Suite 250, 9166 Anaheim Place, Rancho Cucamonga, CA 91730

UK	REP
-----------	------------

YH CONSULTING LIMITED. C/O YH Consulting Limited Office 147, Centurion House, London Road, Staines-upon-Thames, Surrey, TW18 4AX

EC	REP
-----------	------------

E-CrossStu GmbH
Mainzer Landstr.69,
60329 Frankfurt am Main.

