

VEVOR[®]

TOUGH TOOLS, HALF PRICE

Technical Support and E-Warranty Certificate <https://www.vevor.com/support>

LIFTING FLAT TABLE USER MANUAL

We continue to be committed to provide you tools with competitive price.

"Save Half", "Half Price" or any other similar expressions used by us only represents an estimate of savings you might benefit from buying certain tools with us compared to the major top brands and does not necessarily mean to cover all categories of tools offered by us. You are kindly reminded to verify carefully when you are placing an order with us if you are actually saving half in comparison with the top major brands.

VEVOR[®]

TOUGH TOOLS, HALF PRICE

Lifting Flat Table

MODEL NO.: ZWE-DDJ-SS-01, ZWE-DDJ-SS-02, ZWE-DDJ-SS-03,
ZWE-DDJ-SS-04, ZWE-DDJ-SS-05, ZWE-DDJ-SS-06, ZWE-DDJ-SS-07
ZWE-DDJ-SS-08

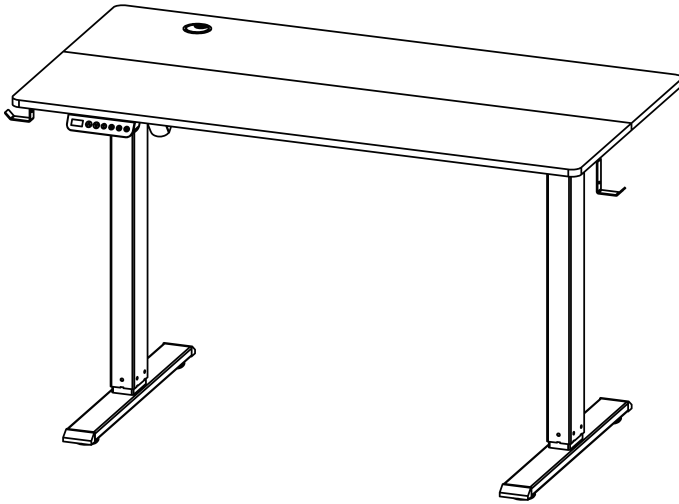

NEED HELP? CONTACT US!

Have product questions? Need technical support? Please feel free to contact us:

Technical Support and E-Warranty Certificate
www.vevor.com/support

This is the original instruction, please read all manual instructions carefully before operating. VEVOR reserves a clear interpretation of our user manual. The appearance of the product shall be subject to the product you received. Please forgive us that we won't inform you again if there are any technology or software updates on our product.

 **WARNING:**

Please read this manual carefully before using the product. Failure to do so may result in serious injury. SAVE THIS MANUAL

ASSEMBLY PRECAUTIONS

1. Assemble only according to these instructions. Improper assembly can create hazards.
2. Wear ANSI-approved safety goggles and heavy-duty work gloves during assembly.
3. Keep the assembly area clean and well-lit.
4. Keep bystanders out of the area during assembly.
5. Do not assemble when tired or when under the influence of alcohol, drugs, or medication.
6. The product capabilities apply to properly and completely assembled products only.
7. Assemble on a flat, level, hard, and smooth surface capable of safely supporting the Lifting Flat Table.
8. For additional information regarding the parts listed in the following pages, please refer to the Assembly Diagram of this manual. Unwrap and separate all parts on a clear work area.

USE PRECAUTIONS

TO PREVENT SERIOUS INJURY AND DEATH FROM TIPPING:









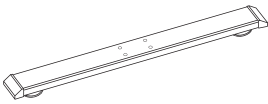
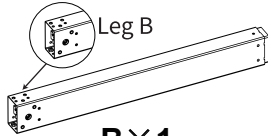
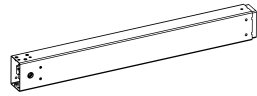

1. This product is not a toy. Do not allow children to play with or approach this item.
2. Use as intended only. Do not sit or stand on the table.
3. Inspect before every use. Do not use it if parts are loose or damaged. Use only on flat, level, and hard surfaces.

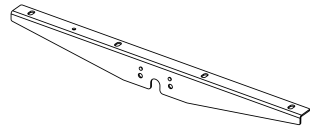

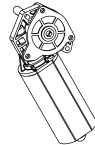
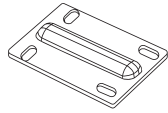

TECHNICAL SPECIFICATIONS

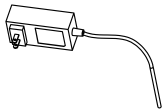
| | | |
|----------------------------|--------------------------------|--------------------------------|
| Model | ZWE-DDJ-SS-01 ZWE-DDJ-SS-02 | ZWE-DDJ-SS-03 ZWE-DDJ-SS-04 |
| Adapter Rating(s) | 100-240V~, 50/60Hz, 1.5A | |
| Main Material | Steel + Board | Steel + Board |
| Color | Brown + Black | Brown + Black |
| Product Dimensions (LxWxH) | 1200 x 600 x 1145 mm | 1200 x 800 x 1145 mm |
| Packing Size (LxWxH) | 1295 x 395 x 120 mm | 1295 x 495 x 120 mm |
| Net Weight (kg) | 21.8 | 25.2 |
| Gross Weight (kg) | 24.5 | 27.9 |

| | | |
|----------------------------|--------------------------------|--------------------------------|
| Model | ZWE-DDJ-SS-05 ZWE-DDJ-SS-06 | ZWE-DDJ-SS-07 ZWE-DDJ-SS-08 |
| Adapter Rating(s) | 100-240V~, 50/60Hz, 1.5A | |
| Main Material | Steel + Board | Steel + Board |
| Color | Brown + Black | Brown + Black |
| Product Dimensions (LxWxH) | 1400 x 600 x 1145 mm | 1400 x 700 x 1145 mm |
| Packing Size (LxWxH) | 1493 x 405 x 120 mm | 1490 x 455 x 120 mm |
| Net Weight (kg) | 23.2 | 24.9 |
| Gross Weight (kg) | 26.1 | 27.9 |

PACKAGE CONTENTS

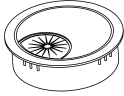
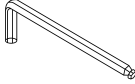
| | | |
|---|--|--|
|  <p>A×2</p> |  <p>B×1</p> |  <p>C×1</p> |
|  <p>D×2</p> | |  <p>E×2</p> |
|  <p>F×1</p> |  <p>G×1</p> | |
|  <p>H×1</p> | |  <p>I×1</p> |
|  <p>J×3</p> |  <p>K×4</p> |  <p>L×1</p> |
|  <p>M×1</p> |  <p>N×38 M6*13</p> |  <p>O×2 ST4*12</p> |

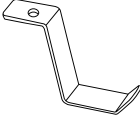
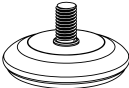
| | | |
|--|---|--|
|  <p>M4*40</p> <p>P×2</p> |  <p>M6*35</p> <p>Q×8</p> |  <p>R×1</p> |
|  <p>S×1</p> |  <p>T×4</p> |  <p>U×1</p> |
|  <p>V×2</p> |  <p>W×4</p> | |

ASSEMBLY STEPS

STEP1 Foot installation

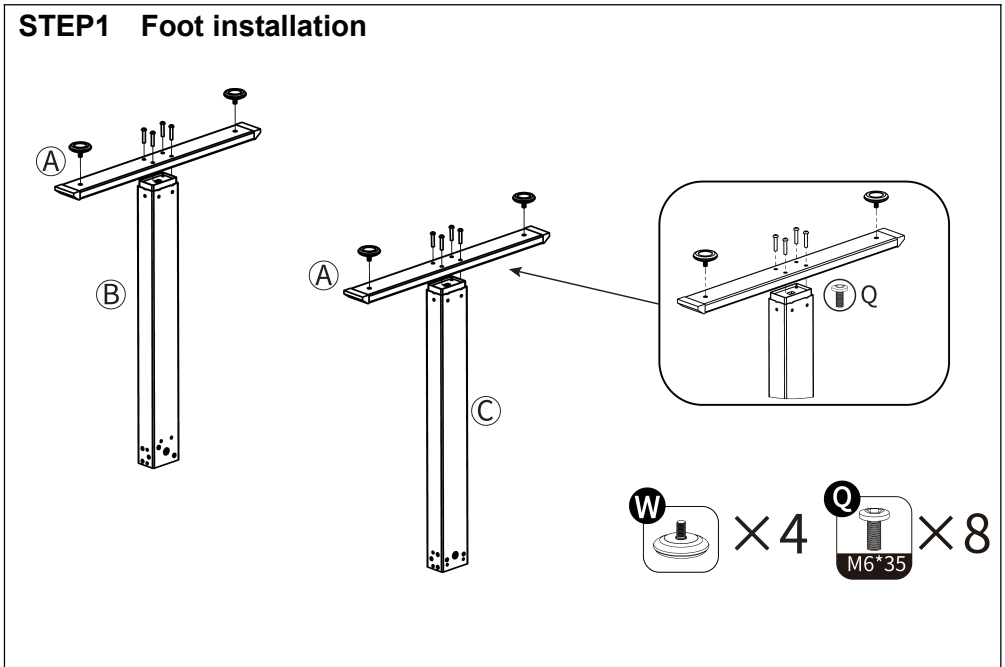

STEP2 Motor installation

①

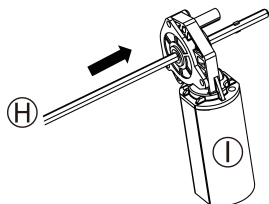

First, insert the motor from the end of the hexagonal rod without a bump to the other end with a bump.

②

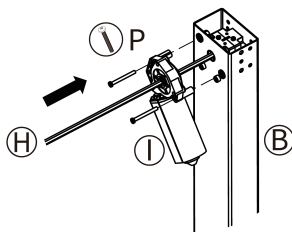

Then, insert the convex end of the motor into leg B together with the motor. Tighten the motor on leg B with the screws shown in the picture.



STEP3 Drive rod installation

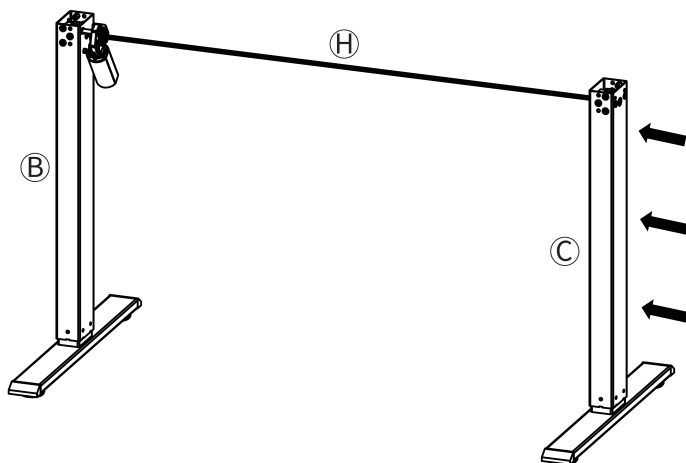

After completing the previous step, insert leg C into the hex stick.



If the holes are misaligned, hold the motor by hand and adjust the hex rod to rotate slightly so that the hex rod can be inserted into leg C.

STEP4 Beam installation

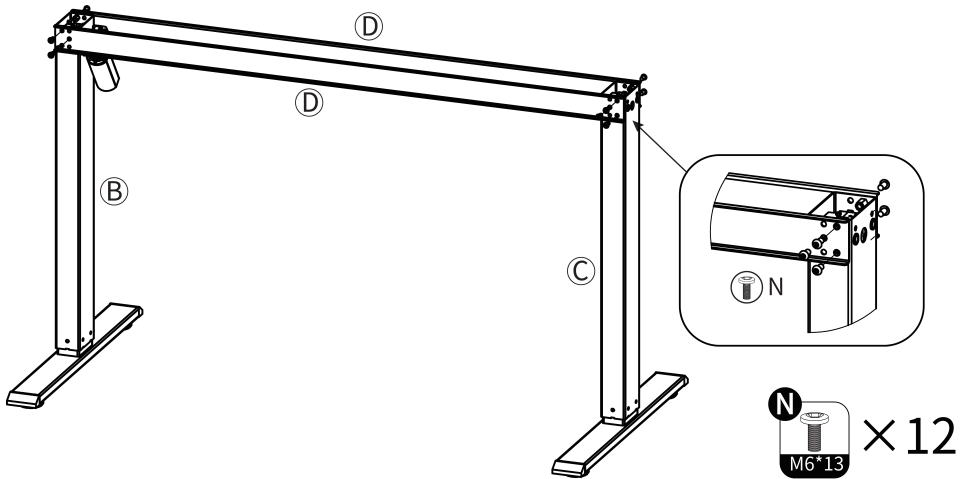

STEP5 Side wing installation

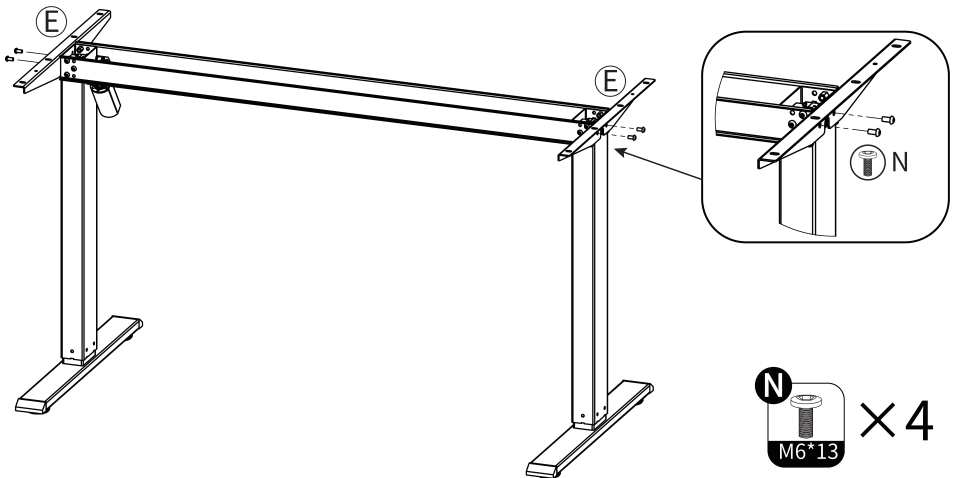

STEP6 Panel splicing (1)

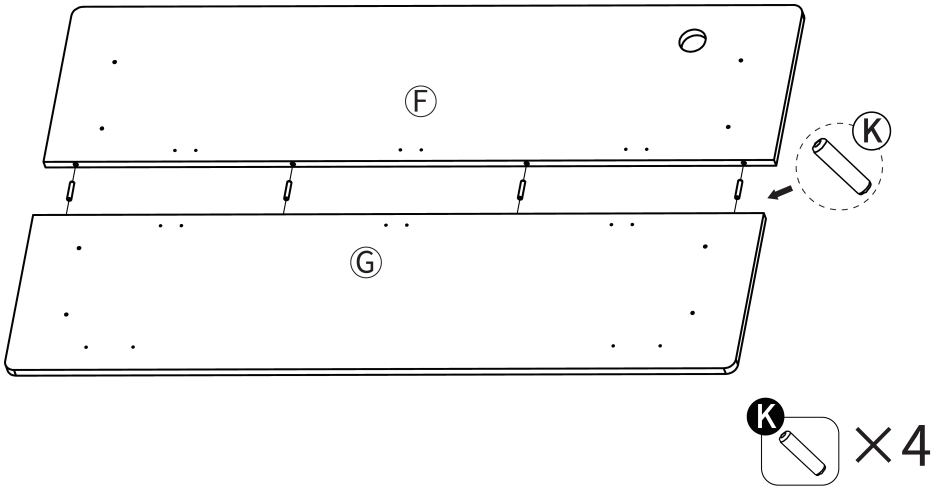

STEP6 Panel splicing (2)

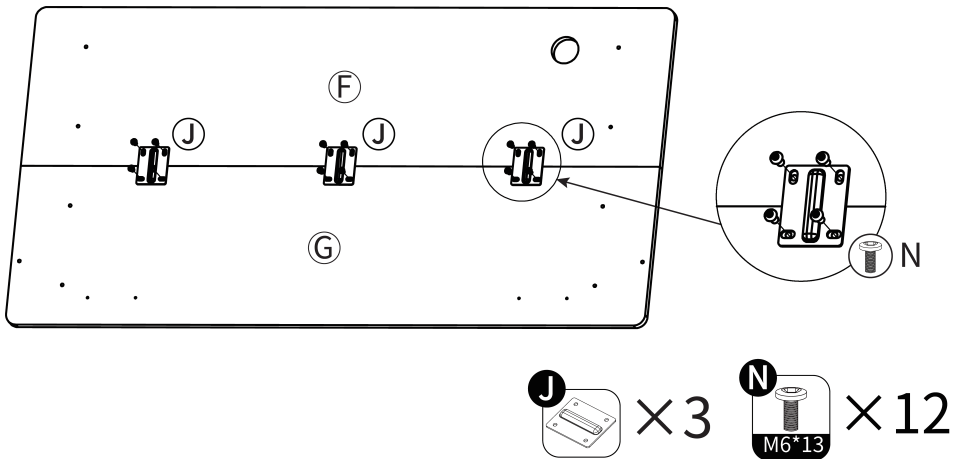

STEP7 Panel installation

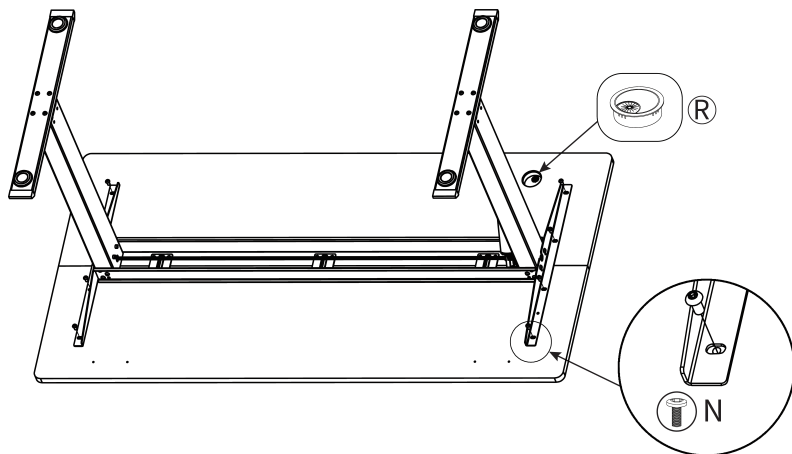

R × 1 **N** × 8
M6*13

STEP8 Accessories installation

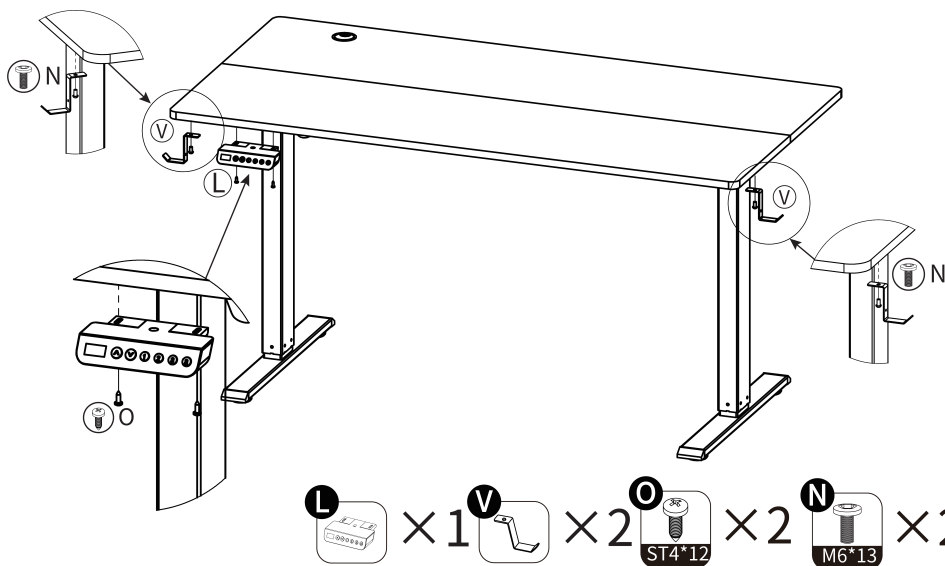

L × 1 **V** × 2 **O** × 2 **N** × 2
ST4*12 M6*13

STEP9 Line connection

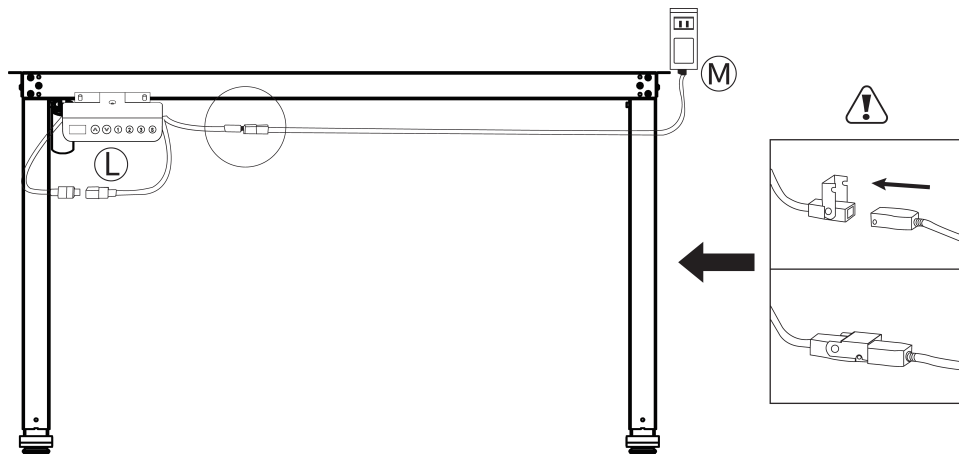

Height Adjustment Controller Operation

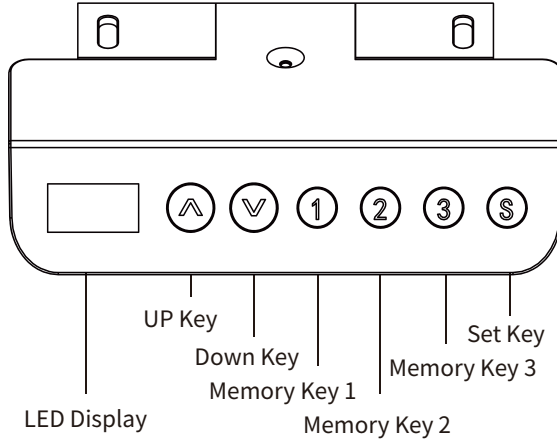

- LED Display:
Press any key once to wake up the LED display.
- UP Key:
Press and hold the UP key to raise the desk.
- Down Key:
Press and hold the DOWN key to lower the desk.
- Memory Key:



You must complete the Initialization Process to reset your desk before using it for the first time.

Detailed introduction of key functions

Reset

After running to the lowest height position, press and hold for 7 seconds. When the LED screen "rst" and "E-1" flash alternately, release the ↓ key, and press and hold the key again. After the desktop runs down to the lowest mechanical zero point, go back 5mm, the LED screen displays the lowest height value, and the reset is completed.

Set memory height + //

Press the S key once, and the height value will start flashing. At this time, press the 1, 2, and 3 keys to save the current height to the corresponding position.

Execute memory height

In normal state, press the number key to call up its corresponding height, and the lifting table will automatically run to the corresponding position.

Lock key (S)

Press and hold the S key for 3 seconds. When the LED screen displays "SET", learn to open the S key. Press the number key 3 to enter the lock screen state. At this time, the LED screen flashes and displays "OFF".

When the screen is locked, press and hold the S key for 3s, and the LED screen displays the height value. At this time, release the S key to complete the unlocking.

Restore factory settings (S)

Press and hold the S key for 9 seconds, release the S key when the LED screen displays "FAC", and operate the S key again to restore the factory settings.

Error Code Instructions

| Error Code | Reason | Solution |
|------------|--|---|
| Err | Err is displayed when the communication line sequence between the manual controller and the control box is wrong | / |
| E-1 | When the system does not save the current position, the LED screen flashes alternately to display "E-1" | Reset by pressing the long key until the LED screen displays the minimum height and the alarm is released |
| E-2 | When the motor is locked, the LED displays E-2 | / |
| E-5 | When the motor appears: the connecting line is disconnected/loosened, the LED screen flashes alternately to display "E-5" | 1. Check the connection lines between all motors and the controller to ensure that they are firm, and then reset by long pressing the down key until the LED screen displays the minimum height, and remove the alarm |
| ovr | When the load exceeds the set value, the LED screen flashes to display ovr. At this time, it is necessary to remove the weight of the desktop and power on the controller after powering off. This alarm can be relieved | 1. Normal load shall be controlled below 120KG 2. When the current exceeds 4A, the overload protection function will be triggered |
| hot | When the internal temperature of the controller exceeds 60 ± 5 degrees, the LED displays hot | / |

| | | |
|-----|--|--|
| voL | When the input voltage of the controller exceeds 34V, the LED displays voL | <ol style="list-style-type: none"> 1. When the voltage exceeds 32V, the controller is powered off and the LED screen is black; 2. When the voltage drops to 32V, the system will automatically reply and LDE will display the real-time height |
| hot | After the motor runs continuously for 5min, the LED screen displays hot, and it can work normally after waiting for 10min | <ol style="list-style-type: none"> 1. Uninterrupted operation means that the operation interval is within 3s 2. This alarm can also be removed when the control system is powered on again |
| E-3 | During the operation, when suddenly blocked, the LED screen flashes "E-3", stops the action and runs 30mm in the opposite direction, then the LED screen displays the real-time height | It shall be ensured that the table will not vibrate significantly, bump into obstacles or tilt during operation |

COMPLETION

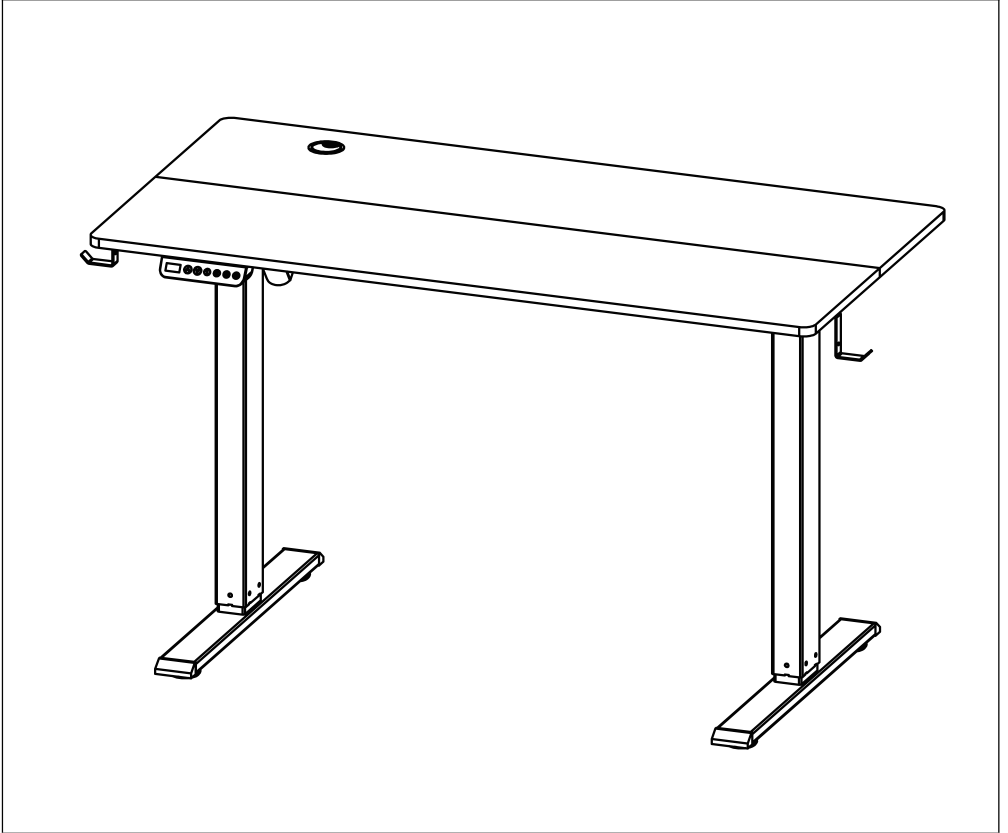

Address: Shuangchenglu 803nong11hao1602A-1609shi, baoshanqu,
shanghai 200000 CN.

Imported to USA: Sanven Technology Ltd., Suite 250, 9166 Anaheim Place,
Rancho Cucamonga, CA 91730

| | |
|-----------|------------|
| EC | REP |
|-----------|------------|

E-CrossStu GmbH.
Mainzer Landstr.69, 60329 Frankfurt am Main.

| | |
|-----------|------------|
| UK | REP |
|-----------|------------|

YH CONSULTING LIMITED.
C/O YH Consulting Limited Office 147, Centurion House,
London Road, Staines-upon-Thames, Surrey, TW18 4AX

VEVOR[®]

TOUGH TOOLS, HALF PRICE

Technical Support and E-Warranty Certificate

www.vevor.com/support

VEVOR[®]

TOUGH TOOLS, HALF PRICE

Techniczny Wsparcie i Certyfikat gwarancji elektronicznej

<https://www.vevor.com/support>

PODNOSENIE PŁASKIE TABELA UŻYTKOWNIK PODRĘCZNIK

Nadal jesteśmy zaangażowani w zapewniamy Ci również konkurencyjne cena.

"Ratować „Połowa”, „Połowa ceny” lub jakiegokolwiek inne podobne wyrażenia przez nas tylko reprezentuje

szacunkowe oszczędności, jakie możesz uzyskać kupując u nas określone narzędzia w porównaniu z większymi

najlepsze marki i niekoniecznie oznacza to okładka Wszystko kategorie oferowanych narzędzi przez nas. Ty

Czy uprzejmie przypominamy o dokładnym sprawdzeniu, kiedy jesteś składanie zamówienia nas jeśli jesteś

faktycznie oszczędzając o połowę w porównaniu z najlepszymi, największymi markami.

VEVOR®

TOUGH TOOLS, HALF PRICE

Podnoszenie Stół płaski

MODEL NR : ZWE - DDJ - SS -01, ZWE - DDJ - SS -02, ZWE - DDJ - SS -03,
ZWE - DDJ - SS -04, ZWE - DDJ - SS -05, ZWE - DDJ - SS -06, ZWE -
DDJ - SS -07 ZWE - DDJ - SS -08

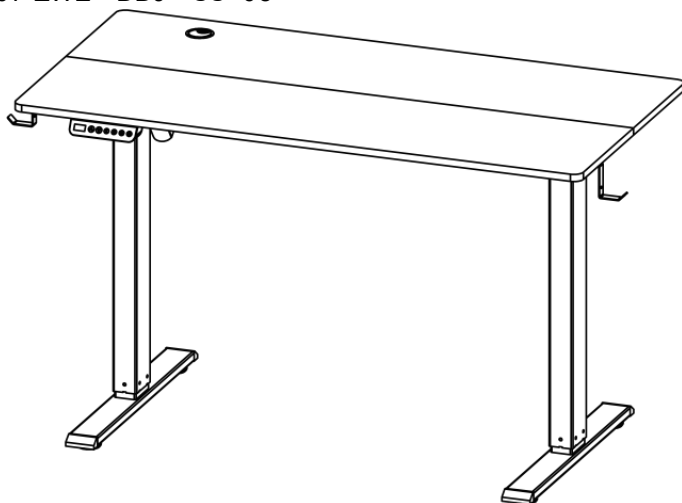

NEED HELP? CONTACT US!

Mieć produkt pytania? Potrzebować techniczny wsparcie? Proszę czuć bezpłatny Do

kontakt nas: **Techniczny Wsparcie I E-gwarancja Certyfikat**
www.vevor.com/support

To jest oryginał instrukcja, Proszę przeczytaj wszystko podręcznik instrukcje

ostrożnie przed uruchomieniem. VEVO R zastrzega sobie jednoznaczna interpretację naszej instrukcji obsługi. Wygląd produktu powinien Być temat do produkt ty otrzymane. Proszę wybaczyć nam, że nie będziemy

poinformuję cię ponownie czy istnieje jakaś technologia lub oprogramowanie Aktualizacje na naszym produkt.



OSTRZEŻENIE:

Proszę przeczytaj to instrukcja obsługi ostrożnie zanim korzystając z produktu . Niepowodzenie zrobić to może skutkować poważnie kontuzja. URATUJ TO PODRĘCZNIK

ŚRODKI OSTROŻNOŚCI PODCZAS MONTAŻU

1. Montaż należy wykonywać wyłącznie zgodnie z niniejszą instrukcją. Nieprawidłowy montaż Móc tworzyć zagrożenia.
2. Nosić Okulary ochronne i wytrzymałe rękawice robocze zatwierdzone przez ANSI w trakcie montażu.
3. Zachowaj miejsce montażu czysty i dobrze oświetlone.
4. Zachowaj osób postronnych poza terenem zgromadzenia.
5. Zrób nie należy się zbierać, gdy jest się zmęczonym lub pod wpływem alkoholu, narkotyki lub lek.
6. Ten możliwości produktu są stosowane prawidłowo i całkowicie zmontowany tylko produkty.
7. Złożyć na płaskiej, równej powierzchni, twarda i gładka powierzchnia zdolny bezpiecznie wspieranie Podnoszenie Stół płaski .
8. W celu uzyskania dodatkowych informacji informacja odnośnie wymienionych części w następnym skrzydle strony, proszę odnieść się do Montaż Schemat tej instrukcji. Odwijać się i oddziel wszystko części na praca przejrzysta obszar.

UŻYWAĆ ŚRODKI OSTROŻNOŚCI

ABY ZAPOBIEC POWAŻNYM OBRAŻENIA I ŚMIERĆ OD NAPIWKÓW:

1. Ten produkt Jest nie zabawka. Do nie pozwalając dzieci do grać z Lub zbliżyć się Ten przedmiot.

2. Używać wyłącznie zgodnie z przeznaczeniem. Do nie siedzieć Lub podstawka NA ten tabela.

3. Inspekcja przed każdym użyciem. Nie używać To Jeśli strony Czy luźny lub uszkodzony. Stosować wyłącznie na powierzchniach płaskich, równych, I twardej powierzchni .









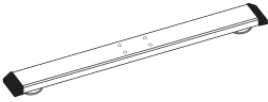
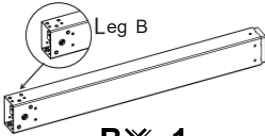
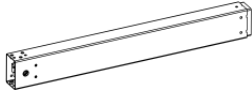

DANE TECHNICZNE

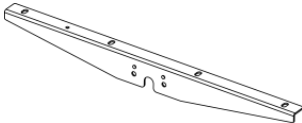



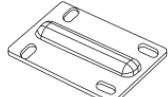

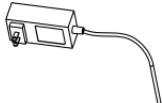

| Model | ZWE-DDJ-SS-01 ZWE-DDJ-SS-02 | ZWE-DDJ-SS-03 ZWE-DDJ-SS-04 |
|--|--------------------------------|--------------------------------|
| Moc(e) adaptera(ów) | 100-240 V~, 50/60 Hz, 1,5 A | |
| Główny Tworzywo | Stal + Tablica | Stal + Tablica |
| Kolor | Brązowy + Czarny | Brązowy + Czarny |
| Produkt Wymiary (Dł. x Szer. x Wys.) | 1200x600x 1145 mm | 1200x800 X 1145 mm |
| Uszczelka Rozmiar (Dł. x Szer. x Wys.) | 1295x395 X 120 mm | 1295x495x 120 mm |
| Masa netto (kg) | 21.8 | 25.2 |
| Masa brutto (kg) | 24,5 | 27.9 |

| Model | ZWE-DDJ-SS-05 ZWE-DDJ-SS-06 | ZWE-DDJ-SS-07 ZWE-DDJ-SS-08 |
|---|--------------------------------|--------------------------------|
| Moc(e) adaptera(ów) | 100-240 V~, 50/60 Hz, 1,5 A | |
| Główny Tworzywo | Stal + Tablica | Stal + Tablica |
| Kolor | Brązowy + Czarny | Brązowy + Czarny |
| Produkt Wymiary (Dł. x Szer. x Wys.) | 1400x600x 1145 mm | 1400x700x 1145 mm |
| Uszczelka Rozmiar (Dł. x | 1493x405x 120 mm | 1490x455x 120 mm |

| | | |
|------------------|------|------|
| Szer. x Wys.) | | |
| Masa netto (kg) | 23.2 | 24,9 |
| Masa brutto (kg) | 26.1 | 27.9 |

ZAWARTOŚĆ OPAKOWANIA

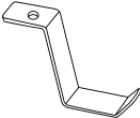
| | | |
|---|--|---|
|  <p>A × 2</p> |  <p>B × 1</p> |  <p>C × 1</p> |
|  <p>D × 2</p> | |  <p>mi × 2</p> |
|  <p>F × 1</p> |  <p>G × 1</p> | |
|  <p>H × 1</p> | |  <p>I × 1</p> |
|  <p>J × 3</p> |  <p>K × 4</p> |  <p>L × 1</p> |
|  <p>M × 1</p> |  <p>N × 38 M6*13</p> |  <p>O × 2 ST 4*12</p> |

| | | |
|--|---|---|
|  <p>M4*40</p> <p>P × 2</p> |  <p>M6*35</p> <p>Q × 8</p> |  <p>R × 1</p> |
|  <p>S × 1</p> |  <p>T × 4</p> |  <p>Ty × 1</p> |
|  <p>V × 2</p> |  <p>W × 4</p> | |

KROKI MONTAŻU

KROK 1 Stopa instalacja

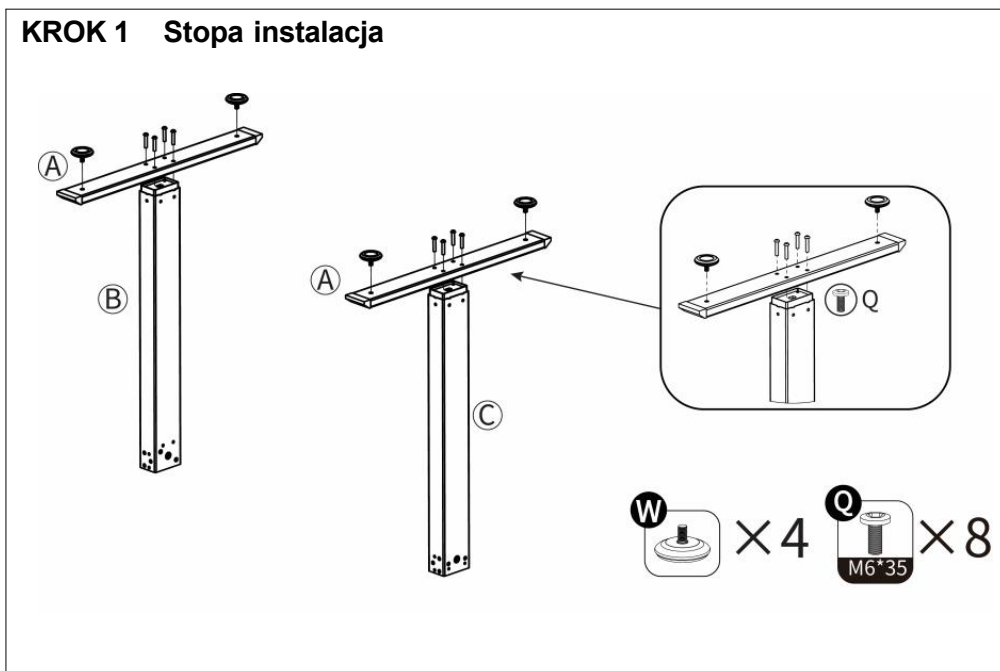

KROK 2 Montaż silnika

①

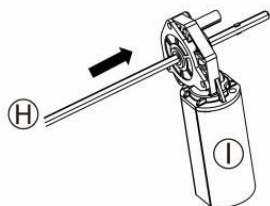

First, insert the motor from the end of the hexagonal rod without a bump to the other end with a bump.

②

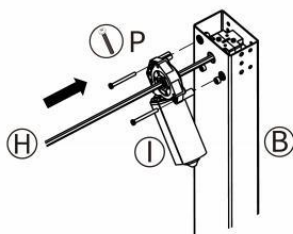

Then, insert the convex end of the motor into leg B together with the motor. Tighten the motor on leg B with the screws shown in the picture.



KROK 3 Prowadzić pręt instalacja

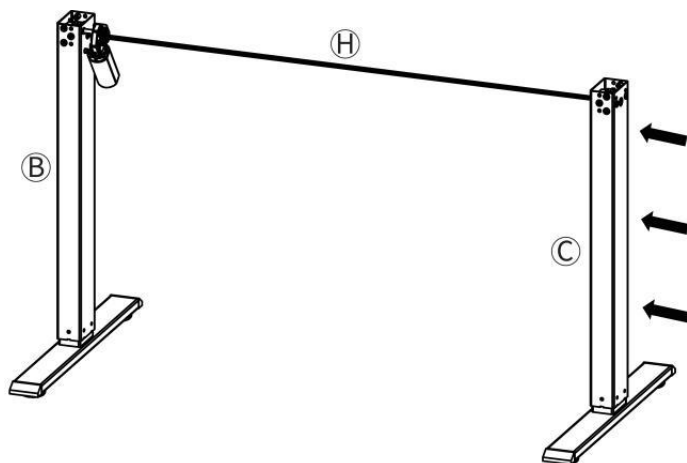

After completing the previous step, insert leg C into the hex stick.



If the holes are misaligned, hold the motor by hand and adjust the hex rod to rotate slightly so that the hex rod can be inserted into leg C.

KROK 4 Belka instalacja

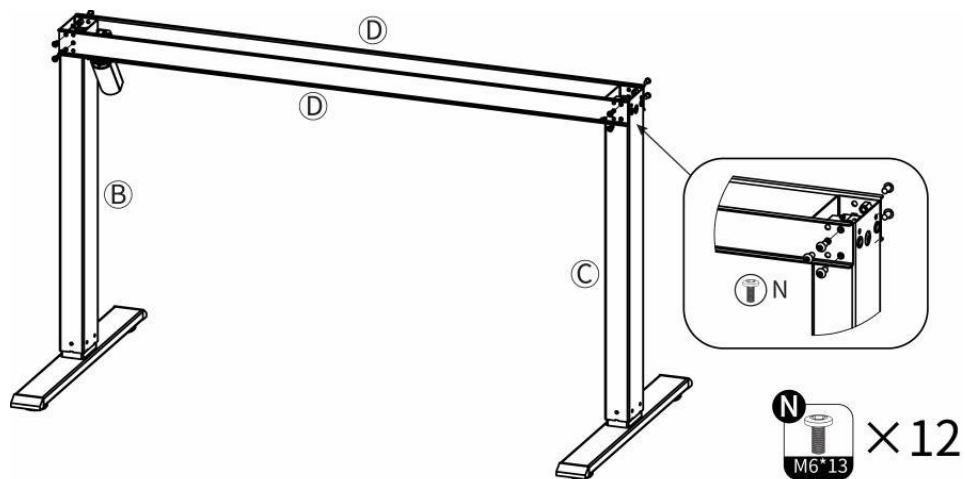

KROK 5 Montaż skrzydła bocznego

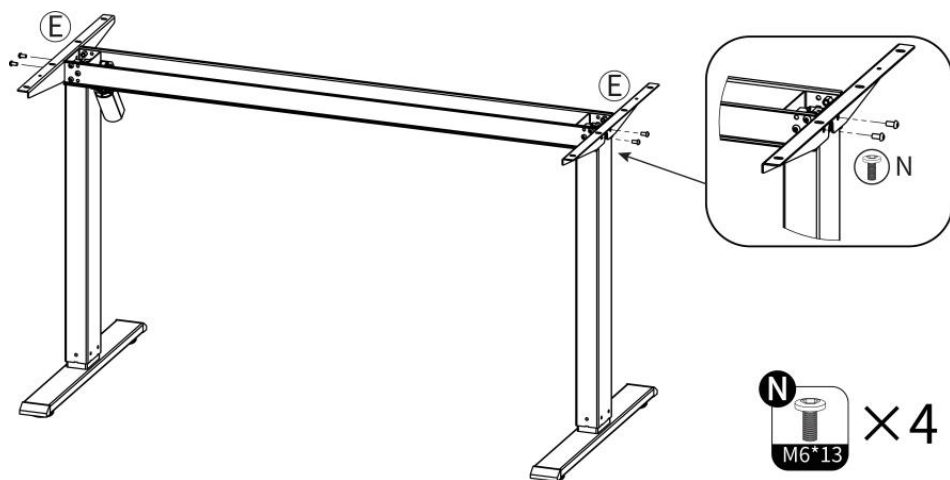

KROK 6 Łączenie paneli (1)

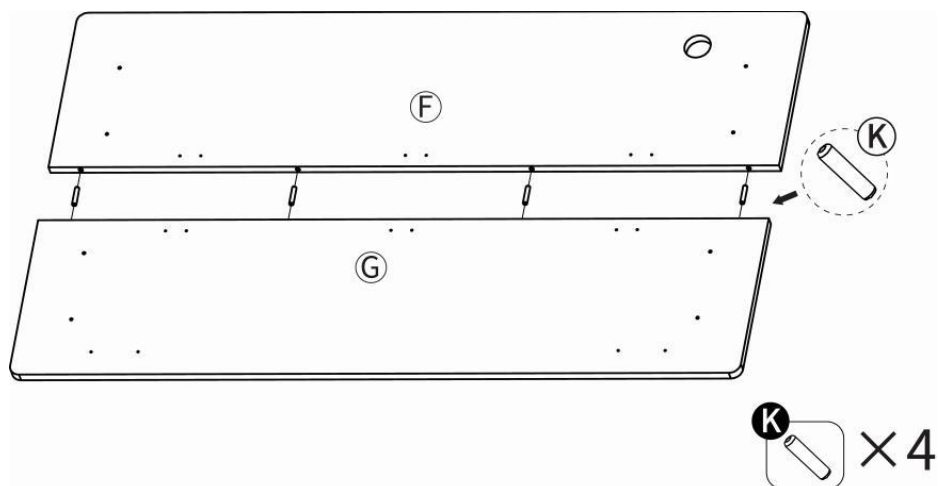

KROK 6 Łączenie paneli (2)

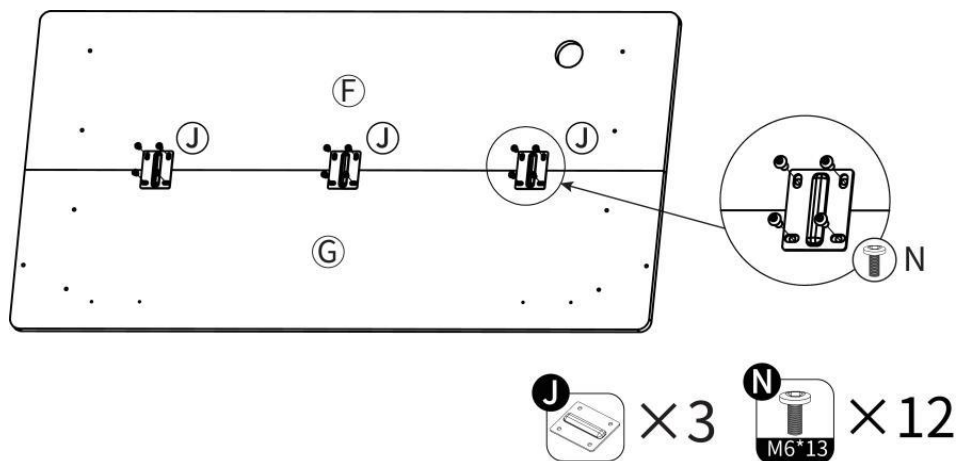

KROK 7 płyta instalacja

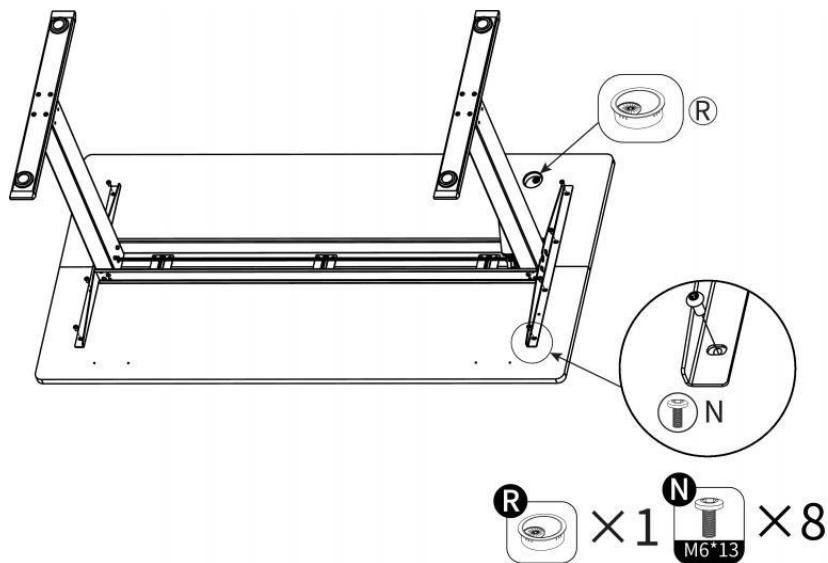

KROK 8 Accessories installation

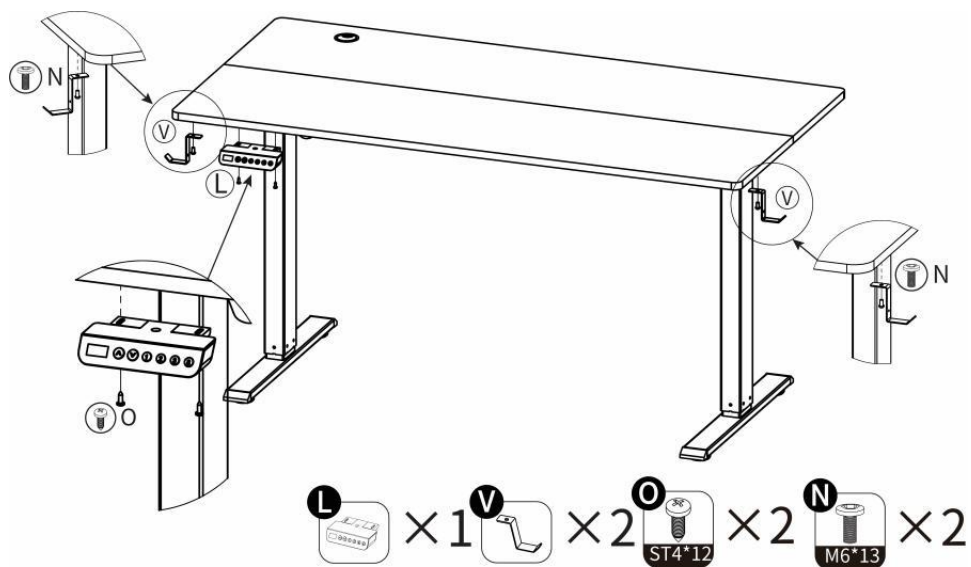

KROK 9 Połączenie liniowe

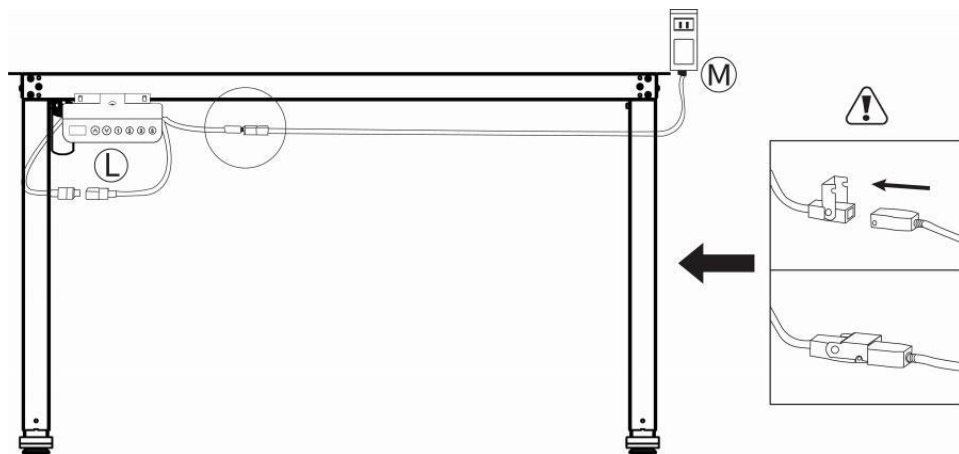

Height Adjustment Controller Operation

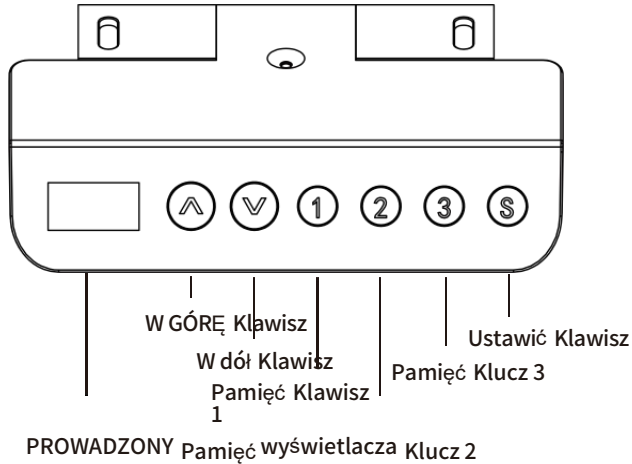

- LED Display:
Press any key once to wake up the LED display.
- UP Key: Press and hold the UP key to raise the desk.
- Down Key: Press and hold the DOWN key to lower the desk.
- Memory Key:



Ty musisz kompletny ten Inicjalizacja Proces Do zresetować twój biurko zanim używając To Do ten Pierwszy czas.

Szczegółowy Wprowadzenie kluczowe funkcje

Nastawić

Po bieganie do najniższy wysokość pozycja, naciskać I przytrzymaj przez 7 sekund. Kiedy ten PROWADZONY ekran "pierwszy" I Błysk „E-1” na przemian, uwolnić ↓ klawisz, I naciskać I trzymać klawisz ponownie. Po pulpitu biegnie w dół do najniższy zero mechaniczne punkt, idź z powrotem 5mm, ten PROWADZONY ekran wyświetlacze ten najniższy wartość wysokości, i nastawić zostało zakończone.

Ustawić pamięć wysokość + / /

Naciśnij S klucz raz, i wartość wysokości będzie start migający. W Ten czas, naciskać ten 1, 2, I 3 klawisze do zapisywania bieżącego wysokość do odpowiedni pozycja.

Wykonać pamięć wysokość

W stan normalny, naciśnij numer klucz do wywołania w górę jego odpowiednik wysokość, I ten podnoszenie tabela będzie automatycznie biegnij do odpowiedniego pozycja.

Zamek klawisz **(S)**

Naciskać I trzymaj S klawisz przez 3 sekundy. Kiedy ten PROWADZONY ekran wyświetlacze "USTAWIĆ", uczyć się Do Otwarte ten S klawisz. Naciśnij numer klawisz 3 aby wejść ekran blokady stan. W Ten czas, ten PROWADZONY ekran błyski i wyświetla "WYŁĄCZONY". Kiedy na ekranie Jest zamknięty, naciskać I trzymaj S klucz na 3s, I ten PROWADZONY ekran wyświetlacze ten wysokość wartość. W tym momencie, uwolnij S klucz do ukończyć odblokowywanie.

Przywróć ustawienia fabryczne **(S)**

Naciskać I trzymaj S klawisz przez 9 sekund, uwolnienie ten S klawisz Kiedy ten e PROWADZONY ekran wyświetlacze "FAC", i obsługiwać S klawisz znowu do przywrócić fabryka Ustawienia.

Błąd Kod Instrukcje

| Błąd Kod | Powód | Rozwiązanie |
|----------|--|---|
| Błądzić | Błądzić Jest wyświetlane, gdy komunikacja sekwencja linii pomiędzy podręcznik kontrola-ler i kontrola skrzynka Jest zło | / |
| E-1 | Kiedy system robi nie zapisz aktualny pozycja, Ekran LED miga na przemian Do wyświetlacz "E-1" | Nastawić przez naciśnięcie długi klawisz aż do Ekran LED wyświetla minimalny m wysokość i alarm Jest wydany |
| E-2 | Kiedy silnik Jest zablokowany, PROWADZONY wyświetlacze E-2 | / |
| E-5 | Kiedy silnik pojawia się: złączony linia Jest odłączyc-ed/poluzowano, Ekran LED błyski na przemian do wyświetlacz "E-5" | 1. Sprawdź połączenie kwestia między Wszystko silniki i kontroler do aby się upewnić, że Oni są twarde, i n nastawić przez długi naciśnięcie w dół klawisz aż do Ekran LED wyświetla minimum wysokość, I usunąć ten alarm |
| poza | Kiedy obciążenie przekracza zestaw wartość, Ekran LED miga Do wyświetlacz ovr. W tym czasie, To Jest konieczne do usuń wagę z pulpit I moc NA ten kontroler Po zasilanie wyłączony. To alarm Móc Być odciążony | 1. Normalna ładunek musi Być kontrolowany poniżej 120 KG 2. Kiedy aktualny przekracza 4A, przeciążać funkcja ochrony będzie Być wyzwolony |

| | | |
|--------|---|---|
| gorący | Kiedy temperatura wewnętrzna tura z kontroler przekracza 60 ± 5 stopnie, PROWADZONY wyświetlacze gorący | / |
|--------|---|---|

| | | |
|--------|--|---|
| tom | Kiedy napięcie wejściowe regulator przekracza 34V, ten PROWADZONY wyświetla vol | <ol style="list-style-type: none"> 1. Gdy napięcie przekracza 32V, ten kontroler Jest napędzany wyłącz i PROWADZONY ekran Jest czarny; 2. Gdy napięcie spada do 32V, ten system będzie automatycznie odpowiedź I LDE będzie wyświetlić w czasie rzeczywistym wysokość |
| gorący | Po silnik biegnie ciąg dalszy przez 5 minut, PROWADZONY ekran wyświetlacze gorący, I To może pracować normalnie po czekaniu na 10 minut | <ol style="list-style-type: none"> 1. Nieprzerwany działanie oznacza, że działanie interwał jest w ciągu 3 sekund 2. To alarm Móc Również Być usunięto kiedy ten układ sterowania Jest napędzany NA Ponownie |
| E-3 | Podczas operacji, Kiedy Nagle zablokowany, PROWADZONY ekran miga „E-3” zatrzymuje działanie I biegnie 30mm w naprzeciwko kierunku, a następnie Wyświetlacze LED ten w czasie rzeczywistym wysokość | To powinno Być zapewnić, że stół będzie nie wibrować znacząco, uderzenie do przeszkody lub przechylić podczas działanie |

UKOŃCZENIE



Adres: Shuangchenglu 803nong11hao1602A-1609shi, baoshanqu,
Szanghaj 200000 CN.

Importowany Do Stany Zjednoczone : sanwen Technologia Sp . z o.o. ,
apartament 250 , 9166 Anaheim miejsce, Ranczo cucamonga , Kalifornia
91730



Firma E-CrossStu GmbH.

Mainzer Landstr.69, 60329 Frankfurcie nad
Menem Główny.



KONSULTACJE YH OGRANICZONY.

Doradztwo C/OYH Limitowane Biuro 147, Centurion
Dom, Londyn Droga, Staines-upon-Thames, Surrey,
TW184AX

VEVOR[®]

TOUGH TOOLS, HALF PRICE

Wsparcie techniczne i Certyfikat E-Warranty
www.vevor.com/support

VEVOR[®]

TOUGH TOOLS, HALF PRICE

Technisch Support und E-Garantie-Zertifikat <https://www.vevor.com/support>

FLACH HEBEN TISCH BENUTZER HANDBUCH

Wir sind weiterhin bestrebt, bieten Ihnen Werkzeuge mit wettbewerbsfähigen Preis. "Speichern Halb", "Halber Preis" oder andere ähnliche Ausdrücke von uns nur stellt eine Schätzung der Einsparungen, die Sie durch den Kauf bestimmter Werkzeuge bei uns im Vergleich zu den großen Top-Marken und bedeutet nicht unbedingt Abdeckung alle Kategorien der angebotenen Werkzeuge von uns. Sie

Sind Bitte überprüfen Sie sorgfältig, wenn Sie eine Bestellung aufgeben mit uns wenn Sie tatsächlich sparen die Hälfte im Vergleich zu den Top-Großmarken.

VEVOR®

TOUGH TOOLS, HALF PRICE

Heben Flacher Tisch

MODELL NR. : ZWE - DDJ - SS -01, ZWE - DDJ - SS -02, ZWE - DDJ - SS -03,
ZWE - DDJ - SS -04, ZWE - DDJ - SS -05, ZWE - DDJ - SS -06, ZWE -
DDJ - SS -07 ZWE - DDJ - SS -08

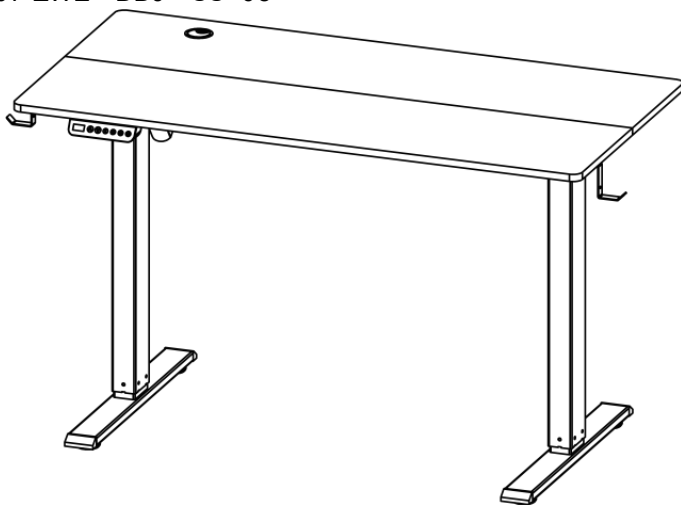

NEED HELP? CONTACT US!

Haben Produkt Fragen? Brauchen technisch Unterstützung? Bitte fühlen frei Zu

Kontakt uns: **Technische Unterstützung Und E-Garantie Zertifikat**
www.vevor.com/support

Dies ist das Original Anweisung, Bitte Anzeige alle lesen Handbuch Anweisungen

sorgfältig vor dem Betrieb. VEVO R behält sich eine klare Interpretation vor unserer Bedienungsanleitung. Das Aussehen des Produkts soll Sei Thema zur

Produkt Sie erhalten. Bitte verzeihen Sie uns, dass wir nicht informiere euch nochmal wenn es Technologien oder Software gibt Updates auf

unserer Produkt.

 **WARNUNG:**

**Bitte Lies das Handbuch sorgfältig vor Verwendung des Produkts.
Versäumnis, tu dies kann resultieren im Ernst Verletzung.
SPEICHERN SIE DIES HANDBUCH**

VORSICHTSMASSNAHMEN BEI DER MONTAGE

1. Die Montage darf nur nach dieser Anleitung erfolgen. Unsachgemäße Montage dürfen erstellen Gefahren.
2. Tragen ANSI-geprüfte Schutzbrille und strapazierfähige Arbeitshandschuhe bei der Montage.
3. Halten Sie den Versammlungsbereich sauber und gut beleuchtet.
4. Behalten Umstehende Personen während der Versammlung aus dem Bereich fernhalten.
5. Tun Sie nicht zusammenkommen, wenn man müde ist oder wenn unter dem Einfluss von Alkohol, Drogen oder Medikamente.
6. Der Produktfunktionen gelten für richtig und vollständig montiert Nur Produkte.
7. Auf einer flachen, ebenen Fläche montieren, harte und glatte Oberfläche fähig von sicher Unterstützung der Heben Flacher Tisch.
8. Für weitere Information bezüglich der aufgeführten Teile im folgenden Seiten, bitte siehe die Montage Diagramm dieses Handbuchs. Auspacken und trennen Sie alle Teile auf einem klare Arbeit Bereich.

VERWENDEN VORSICHTSMASSNAHMEN

UM SCHWERE VERLETZUNG UND TOD VOM TRINGELD:

1. Das Produkt Ist kein Spielzeug. Tun nicht erlauben Kinder zu spielen mit oder Ansatz Das Artikel.

2. Nur bestimmungsgemäß verwenden. Tun nicht sitzen oder Stand An Die Tisch.









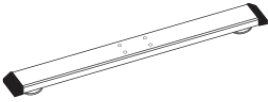
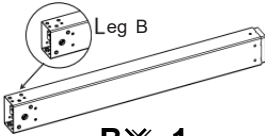
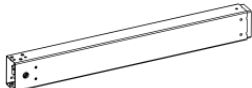

3. Prüfen vor jedem Gebrauch. Nicht verwenden Es Wenn Teile Sind lose oder beschädigt. Nur auf flachen, ebenen, Und hart Oberflächen .

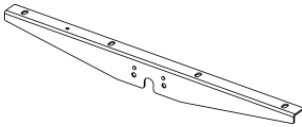



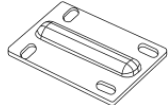

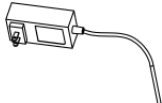

TECHNISCHE DATEN

| Modell | ZWE-DDJ-SS-01 ZWE-DDJ-SS-02 | ZWE-DDJ-SS-03 ZWE-DDJ-SS-04 |
|--------------------------|--------------------------------|--------------------------------|
| Adapterbewertung(en) | 100-240V~, 50/60Hz, 1,5 A | |
| Hauptsächlich Material | Stahl + Planke | Stahl + Planke |
| Farbe | Braun + Schwarz | Braun + Schwarz |
| Produkt Maße (LxBxH) | 1200 x 600 x 1145 mm | 1200 x 800 X 1145 mm |
| Verpackung Größe (LxBxH) | 1295 x 395 X 120 mm | 1295 x 495 x 120 mm |
| Nettogewicht (kg) | 21.8 | 25.2 |
| Bruttogewicht (kg) | 24,5 | 27,9 |

| Modell | ZWE-DDJ-SS-05 ZWE-DDJ-SS-06 | ZWE-DDJ-SS-07 ZWE-DDJ-SS-08 |
|--------------------------|--------------------------------|--------------------------------|
| Adapterbewertung(en) | 100-240V~, 50/60Hz, 1,5 A | |
| Hauptsächlich Material | Stahl + Planke | Stahl + Planke |
| Farbe | Braun + Schwarz | Braun + Schwarz |
| Produkt Maße (LxBxH) | 1400 x 600 x 1145 mm | 1400 x 700 x 1145 mm |
| Verpackung Größe (LxBxH) | 1493 x 405 x 120 mm | 1490 x 455 x 120 mm |
| Nettogewicht (kg) | 23.2 | 24.9 |
| Bruttogewicht (kg) | 26.1 | 27,9 |

PACKUNGSINHALT

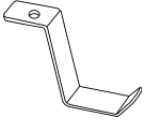
| | | |
|--|---|--|
|  <p>AX 2</p> |  <p>BX 1</p> |  <p>CX 1</p> |
|  <p>DX 2</p> | |  <p>EX 2</p> |
|  <p>FX 1</p> |  <p>GX 1</p> | |
|  <p>HX 1</p> |  <p>IXH 1</p> | |
|  <p>JX 3</p> |  <p>KX 4</p> |  <p>MX 1</p> |
|  <p>MX 1</p> |  <p>NX 38 M6*13</p> |  <p>OX 2 ST 4*12</p> |

| | | |
|--|---|--|
|  <p>M4*40</p> <p>P × 2</p> |  <p>M6*35</p> <p>Q × 8</p> |  <p>R × 1</p> |
|  <p>S × 1</p> |  <p>T × 4</p> |  <p>U × 1</p> |
|  <p>V × 2</p> |  <p>B × 4</p> | |

MONTAGEANLEITUNG

SCHRITT 1 Fuß Installation

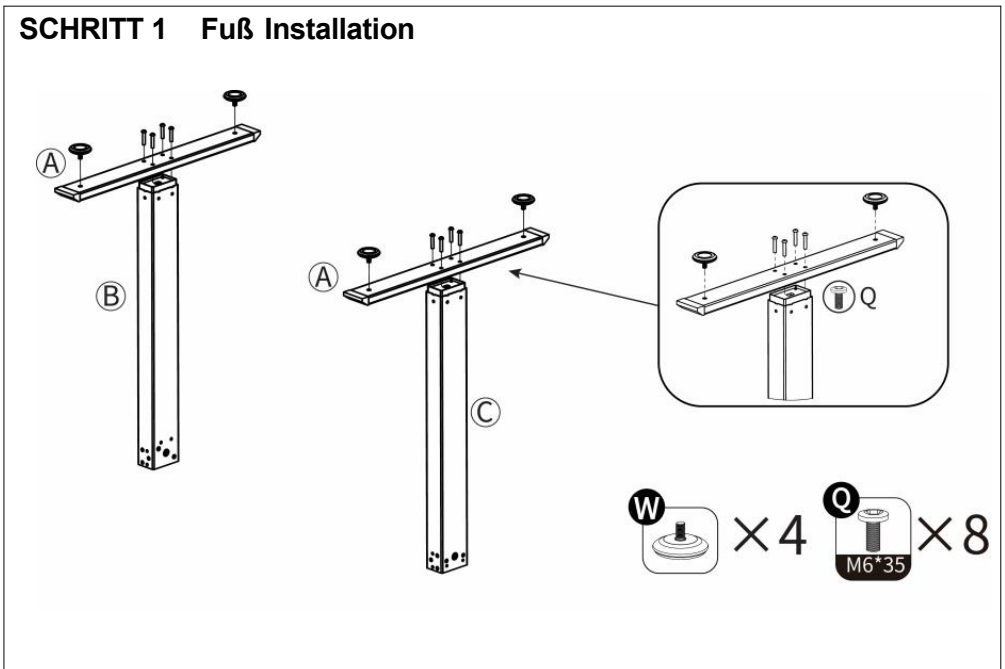

SCHRITT2 Einbau des Motors

①

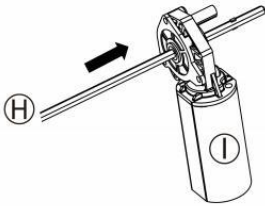

First, insert the motor from the end of the hexagonal rod without a bump to the other end with a bump.

②

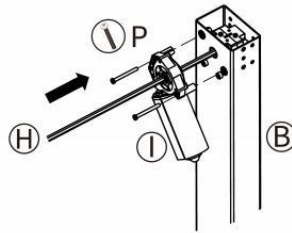

Then, insert the convex end of the motor into leg B together with the motor. Tighten the motor on leg B with the screws shown in the picture.



SCHRITT3 Fahren Stange Installation

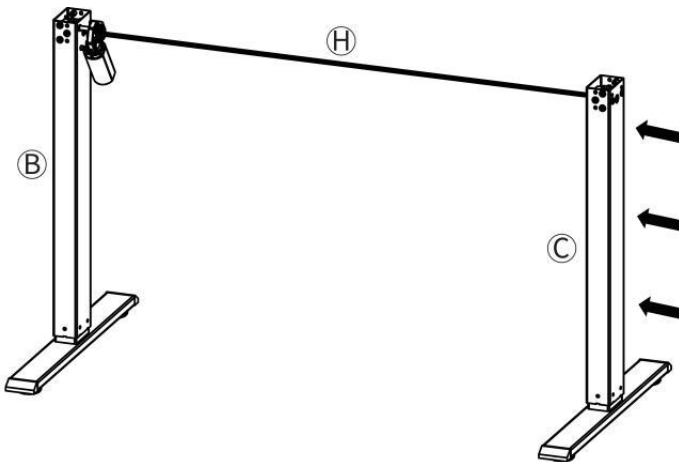

After completing the previous step, insert leg C into the hex stick.



If the holes are misaligned, hold the motor by hand and adjust the hex rod to rotate slightly so that the hex rod can be inserted into leg C.

SCHRITT4 Strahl Installation

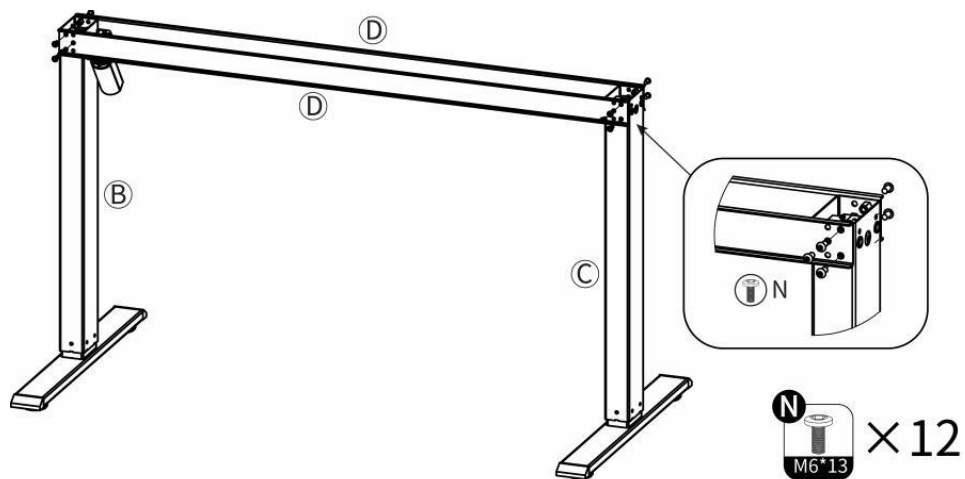

SCHRITT 5 Seitenflügelmontage

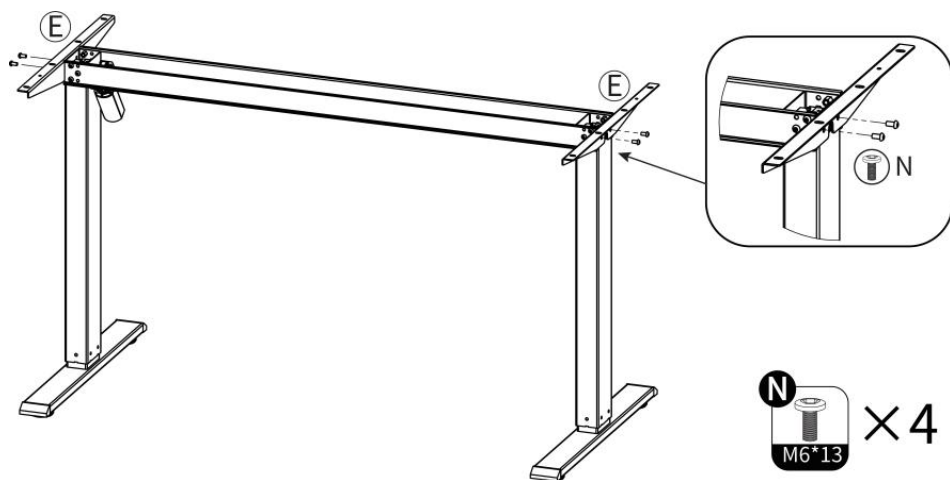

SCHRITT 6: Plattenspleißen (1)

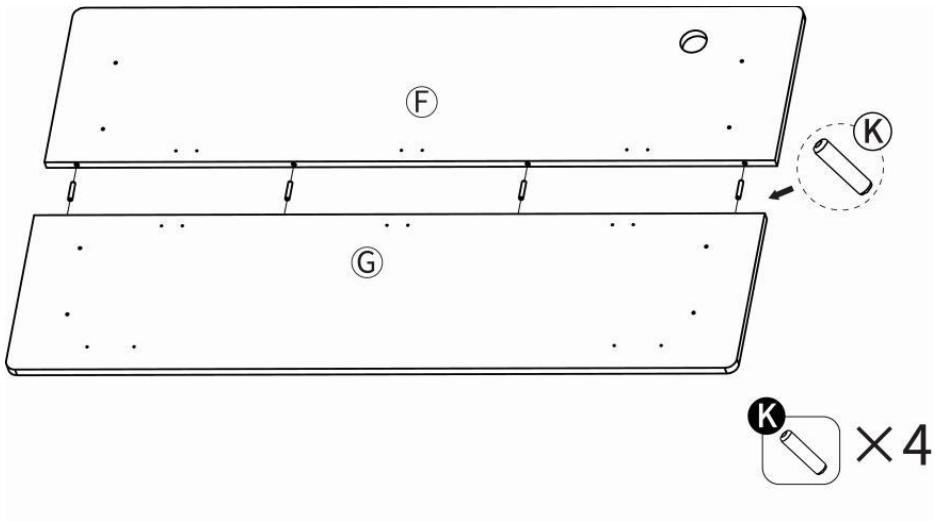

SCHRITT6 Plattenverbindung (2)

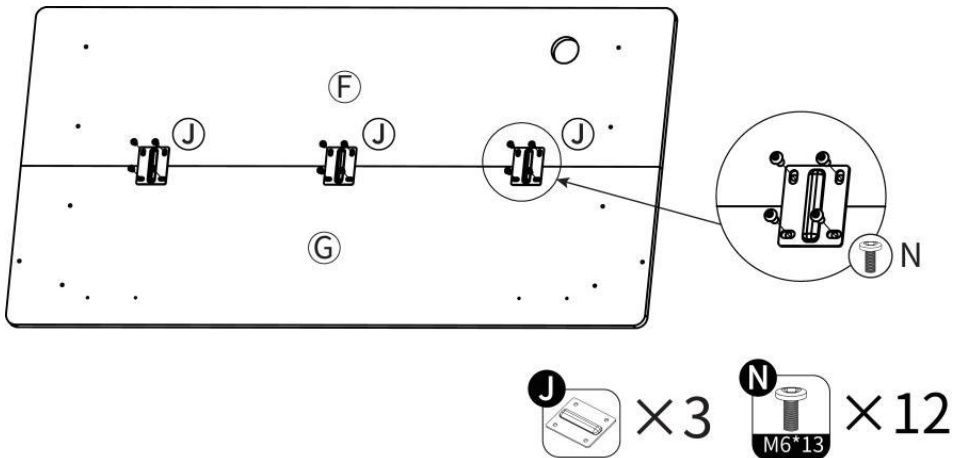

SCHRITT 7 Bedienfeld Installation

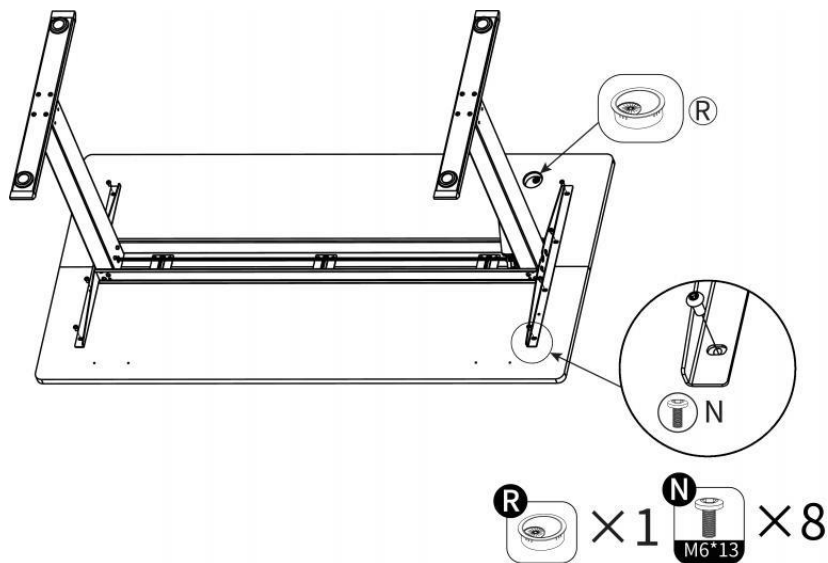

SCHRITT 8 Accessories installation

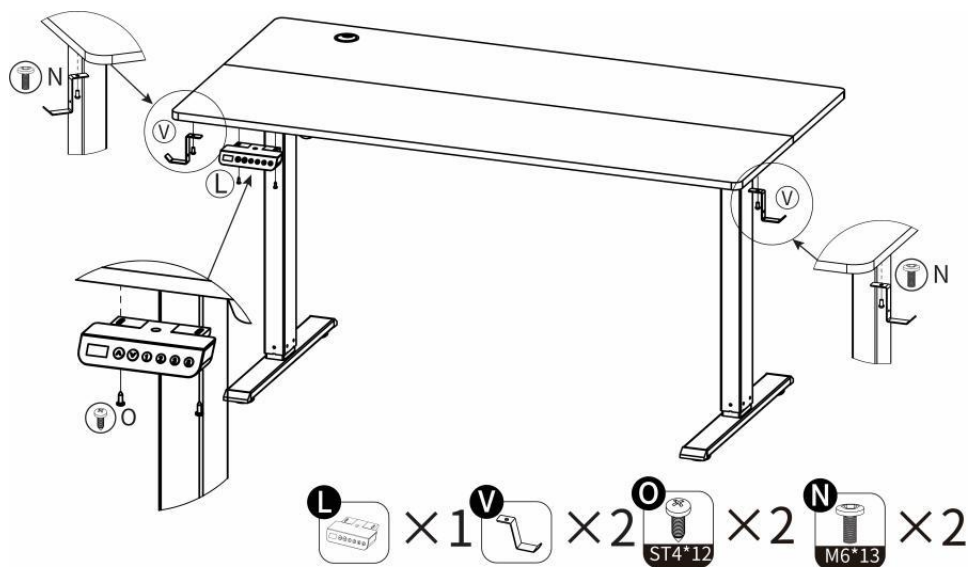

SCHRITT9 Leitungsanschluss

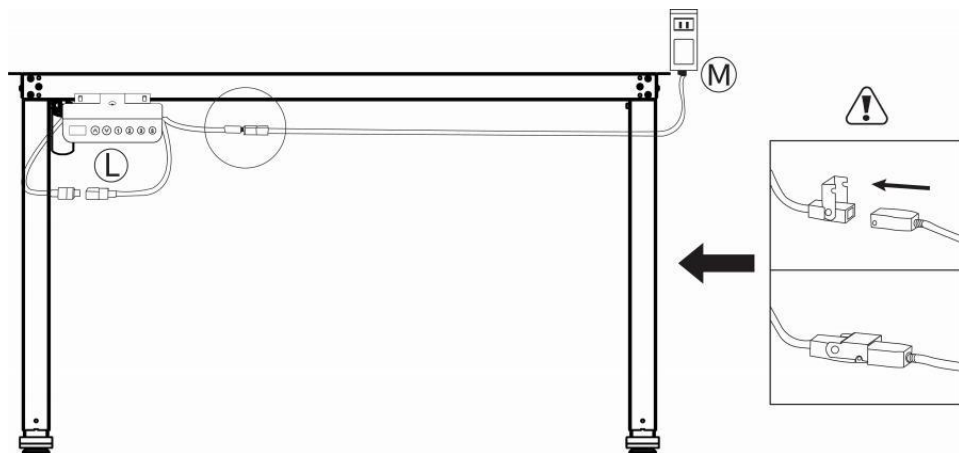

Height Adjustment Controller Operation

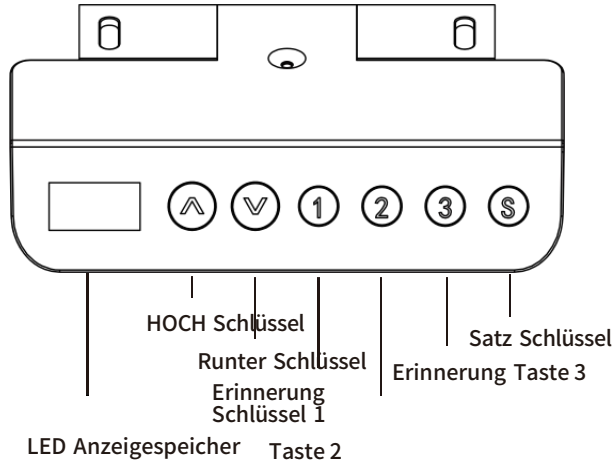

- LED Display: Press any key once to wake up the LED display.
- UP Key: Press and hold the UP key to raise the desk.
- Down Key: Press and hold the DOWN key to lower the desk.
- Memory Key:



Du muss vollständig Die Initialisierung Verfahren Zu zurücksetzen dein Schreibtisch vor mit Es für Die zuerst Zeit.

Detaillierte Einführung von Tastenfunktionen

Zurücksetzen

Nach läuft zum niedrigste Höhe Position, drücken Und 7 Sekunden lang gedrückt halten. Wenn Die LED Bildschirm "erste" Und "E-1" blinkt abwechselnd, lasse die ↓ los Schlüssel, Und drücken Und halten Sie die Schlüssel wieder. Nach dem Desktop-Computer läuft hinunter zum niedrigste mechanischer Nullpunkt Punkt, gehen zurück 5 mm, Die LED Bildschirm zeigt Die niedrigste Höhenwert, und die zurücksetzen ist abgeschlossen.

Satz Erinnerung Höhe + / /

Drücken Sie die S einmal drücken, und die Der Höhenwert wird Start blinkt. Bei Das Zeit, drücken Die 1, 2, Und 3 Tasten zum Speichern der aktuellen Höhe bis zum entsprechend Position.

Ausführen Erinnerung Höhe

In Normalzustand, Drücken Sie die Nummer Taste zum Anrufen hoch die entsprechend Höhe, Und Die Heben Tisch Wille automatisch laufe zum entsprechend Position.

Sperrern Schlüssel (S)

Drücken Und halte die S 3 Sekunden lang gedrückt. Die LED Bildschirm zeigt "SATZ", lernen Zu offen Die S Schlüssel. Drücken Sie die Nummer Taste 3 zur Eingabe der Sperrbildschirm Zustand. Bei Das Zeit, Die LED Bildschirm blinkt und Displays "AUS".

Wenn der Bildschirm Ist gesperrt, drücken Und halte die S Taste für 3s, Und Die LED Bildschirm zeigt Die Höhe Wert. Zu diesem Zeitpunkt Lassen Sie die S Schlüssel zu Vervollständigen Sie die Entriegelung.

Werkseinstellungen wiederherstellen (S)

Drücken Und halte die S -Taste 9 Sekunden gedrückt halten, freigeben Die S Schlüssel Wann Die LED Bildschirm zeigt "FAC", und betätigen Sie die S Schlüssel wieder zu Wiederherstellen der Fabrik Einstellungen.

Fehler Code Anweisungen

| Fehler Code | Grund | Lösung |
|-------------|--|---|
| Ähm | Ähm Ist angezeigt, wenn die Kommunikation Zeilenfolge zwischen den Handbuch Kontrolle- ler und die Kontrolle Kasten Ist falsch | / |
| E-1 | Wenn das System tut nicht Speichern Sie die aktuell Position , die LED-Bildschirm blinkt abwechselnd Zu Anzeige "E-1" | Zurücksetzen von Drücken der lang Schlüssel bis zum LED-Bildschirm zeigt die Minimum m Höhe und die Alarm Ist freigegeben |
| E-2 | Wenn das Motor Ist gesperrt, die LED zeigt E-2 | / |
| G-5 | Wenn das Motor erscheint: die Verbinden Linie Ist trennen- gelockert, die LED-Bildschirm blinkt abwechselnd zu Anzeige "E-5" | 1. Überprüfen Sie die Verbindung Linien zwischen alle Motoren und die Controller zu Stellen Sie sicher, dass Sie sind fest, und das n zurücksetzen von lang Drücken der runter Schlüssel bis zum LED-Bildschirm zeigt die Minimum Höhe, Und entfernen Die Alarm |
| über | Wenn das laden überschreitet den eingestellten Wert, der LED-Bildschirm blinkt Zu Anzeige ovr. Zu diesem Zeitpunkt Es Ist notwendig, um das Gewicht entfernen der Desktop-Computer Und Leistung An Die Regler nach Stromversorgung aus. Dies | 1. Normal Last soll Sei kontrolliert unten 120 kg 2. Wenn die aktuell 4A übersteigt, wird der Überlast Schutzfunktion wird Sei ausgelöst |

| | | |
|------|--|---|
| | Alarm dürfen Sei erleichtert | |
| heiß | Wenn das Innentemperatur der Regler übersteigt 60 ± 5 Grad, die LED zeigt heiß | / |

| | | |
|------|--|---|
| vol | Wenn das Eingangsspannung des Reglerspannung übersteigt 34V, Die LED zeigt voL an | <ol style="list-style-type: none"> 1. Wenn die Spannung übersteigt 32V, Die Regler Ist angetrieben aus und die LED Bildschirm Ist Schwarz; 2. Wenn die Spannung sinkt auf 32V, Die System wird automatisch Antwort Und LDE Wille zeigen Sie die Echtzeit Höhe |
| heiß | Nach dem Motor Läuft weiter- 5 Minuten lang, die LED Bildschirm zeigt heiß, Und Es kann arbeiten normalerweise nach dem Warten auf 10 Minuten | <ol style="list-style-type: none"> 1. Ununterbrochen Betrieb bedeutet, dass die Betrieb Intervall ist innerhalb von 3s 2. Dies Alarm dürfen Auch Sei entfernt, wenn Die Kontrollsystem Ist angetrieben An wieder |
| G-3 | Während der Operation Wann plötzlich blockiert, die LED Bildschirm blinkt "E-3", stoppt die Aktion Und läuft 30mm im Gegenteil Richtung, dann die LED-Bildschirmanzeigen Die Echtzeit Höhe | Es soll Sei sorgte dafür, dass der Tisch Wille nicht stark vibrieren, stoßen hinein Hindernisse oder kippen während Betrieb |

FERTIGSTELLUNG

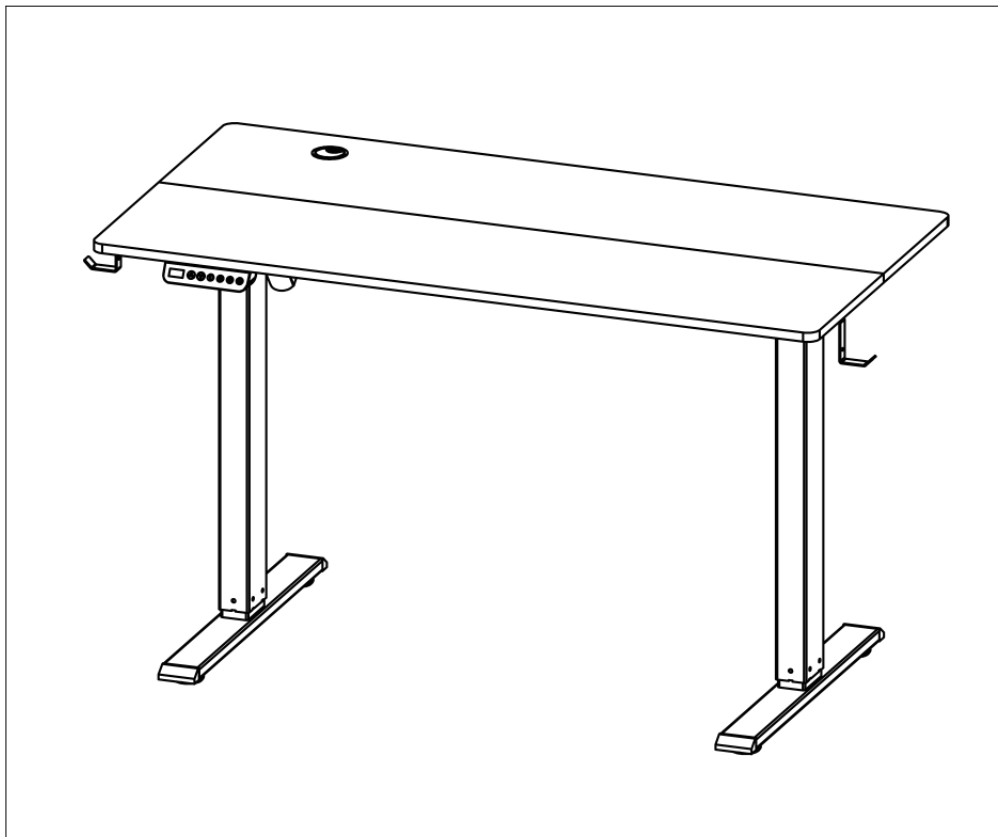

Adresse: Shuangchenglu 803nong11hao1602A-1609shi, baoshanqu,
Shanghai, 200.000 CN.

Importiert Zu Vereinigte Staaten : sanven Technologie GmbH . , Suite 250 ,
9166 Anaheim Ort, Rancho Cucamonga-Standorte, CA 91730

| | |
|-----------|------------|
| EC | REP |
|-----------|------------|

E-CrossStu GmbH.

Mainzer Landstr.69, 60329 Frankfurt am
Hauptsächlich.

| | |
|-----------|------------|
| UK | REP |
|-----------|------------|

YH-BERATUNG BESCHRÄNKT.

C/OYH-Beratung Büro mit beschränkter Haftung 147,
Zenturio Haus, London Straße, Staines-upon-Thames,
Surrey, TW184AX

VEVOR[®]

TOUGH TOOLS, HALF PRICE

Technischer Support und E- Garantie-
Zertifikat www.vevor.com/support

VEVOR[®]

TOUGH TOOLS, HALF PRICE

Technique Soutenir et Certificat de garantie électronique

<https://www.vevor.com/support>

LEVAGE À PLAT TABLEAU UTILISATEUR MANUEL

Nous continuons à nous engager à vous fournir des outils compétitifs prix.

"Sauvegarder Moitié", "Moitié Prix" ou toute autre expression similaire utilisée par nous
seulement représente un

estimation des économies que vous pourriez réaliser en achetant certains outils chez nous par
rapport aux principaux

grandes marques et ne signifie pas nécessairement couverture tous catégories des outils
proposés par nous. Toi

sont nous vous rappelons de bien vouloir vérifier attentivement lorsque vous êtes passer une
commande avec nous si tu es

en fait, je sauve la moitié par rapport aux plus grandes marques.

VEVOR®

TOUGH TOOLS, HALF PRICE

Levage Table plate

MODÈLE N ° : ZWE - DDJ - SS -01, ZWE - DDJ - SS -02, ZWE - DDJ - SS -03,
ZWE - DDJ - SS -04, ZWE - DDJ - SS -05, ZWE - DDJ - SS -06, ZWE -
DDJ - SS -07 ZWE - DDJ - SS -08

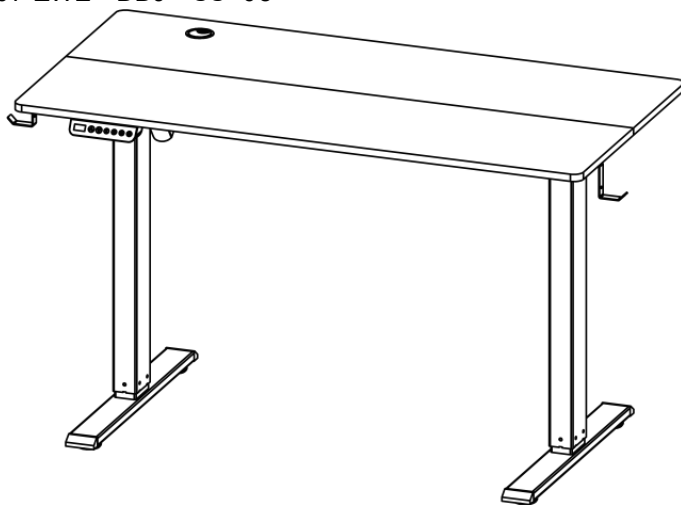

NEED HELP? CONTACT US!

Avoir produit Des questions ? Besoin technique soutien? S'il te plaît sentir gratuit à

contact nous: **Technique Soutien et Garantie électronique Certificat**
www.vevor.com/support

C'est l'original instruction, s'il te plaît lire l'annonce dans son intégralité manuel instructions soigneusement avant l'utilisation. VEVO R se réserve une interprétation claire de notre manuel d'utilisation. L'apparence du produit doit être sujet au produit vous reçu. S'il te plaît, pardonne nous que nous ne le ferons pas je vous informe à nouveau s'il existe une technologie ou un logiciel

mises à jour sur notre produit.



AVERTISSEMENT:

S'il te plaît lis ceci manuel avec soin avant en utilisant le produit. Échec de fais-le peut résulter sérieusement blessure. SAUVEZ CECI MANUEL

PRÉCAUTIONS D'ASSEMBLAGE

1. Assembler uniquement selon ces instructions. Montage incorrect peut créer dangers.
2. Porter Lunettes de sécurité et gants de travail robustes approuvés par l'ANSI pendant le montage.
3. Gardez la zone de montage faire le ménage et bien éclairé.
4. Gardez les spectateurs hors de la zone pendant le montage.
5. Faire ne pas se réunir quand on est fatigué ou quand sous l'influence d'alcool, drogues, ou médicament.
6. Le les capacités du produit s'appliquent correctement et complètement assemblé produits uniquement.
7. Assembler sur une surface plane et de niveau, surface dure et lisse capable de manière sûre soutenir la Levage Table plate .
8. Pour plus d'informations information concernant les pièces listées dans l' aile suivante pages, s'il vous plaît se référer à la Assemblée Schéma de ce manuel. Déballer et séparez tout pièces sur un travail clair zone.

UTILISER PRÉCAUTIONS

POUR PRÉVENIR LES MALADIES GRAVES BLESSURE ET LA MORT DU POURBOIRE :

1. Ce produit est pas un jouet. Faire ne pas permettre enfants à jouer avec ou approche ce article.
2. Utiliser uniquement comme prévu. Faire pas s'asseoir ou rester sur le tableau.









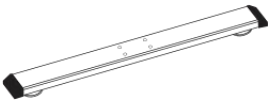
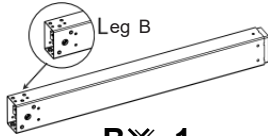
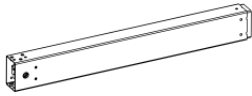

3. Inspect avant chaque utilisation. Ne pas utiliser il si parties sont lâche ou endommagé. Utiliser uniquement sur un sol plat et de niveau. et dur surfaces .

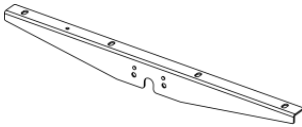



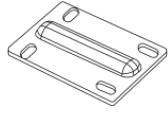

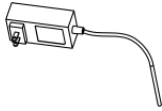

CARACTÉRISTIQUES TECHNIQUES

| Modèle | ZWE-DDJ-SS-01 ZWE-DDJ-SS-02 | ZWE-DDJ-SS-03 ZWE-DDJ-SS-04 |
|--|--------------------------------|--------------------------------|
| Caractéristiques nominales de l'adaptateur | 100-240 V~, 50/60 Hz, 1,5 A | |
| Principal Matériel | Acier + Conseil | Acier + Conseil |
| Couleur | Brun + Noir | Brun + Noir |
| Produit Dimensions (LxlxH) | 1200 x 600 x 1145 mm | 1200 x 800 x 1145 mm |
| Emballage Taille (LxlxH) | 1295 x 395 x 120 mm | 1295 x 495 x 120 mm |
| Poids net (kg) | 21,8 | 25.2 |
| Poids brut (kg) | 24,5 | 27,9 |

| Modèle | ZWE-DDJ-SS-05 ZWE-DDJ-SS-06 | ZWE-DDJ-SS-07 ZWE-DDJ-SS-08 |
|--|--------------------------------|--------------------------------|
| Caractéristiques nominales de l'adaptateur | 100-240 V~, 50/60 Hz, 1,5 A | |
| Principal Matériel | Acier + Conseil | Acier + Conseil |
| Couleur | Brun + Noir | Brun + Noir |
| Produit Dimensions (LxlxH) | 1400 x 600 x 1145 mm | 1400 x 700 x 1145 mm |
| Emballage Taille (LxlxH) | 1493 x 405 x 120 mm | 1490 x 455 x 120 mm |
| Poids net (kg) | 23.2 | 24,9 |
| Poids brut (kg) | 26.1 | 27,9 |

CONTENU DU COLIS

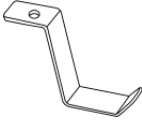
| | | |
|---|--|---|
|  <p>UN × 2</p> |  <p>B × 1</p> |  <p>C × 1</p> |
|  <p>D × 2</p> | |  <p>E × 2</p> |
|  <p>F × 1</p> |  <p>G × 1</p> | |
|  <p>H × 1</p> |  <p>je × 1</p> | |
|  <p>J × 3</p> |  <p>K × 4</p> |  <p>L × 1</p> |
|  <p>M × 1</p> |  <p>N × 38 M6*13</p> |  <p>O × 2 ST 4*12</p> |

| | | |
|--|---|---|
|  <p>M4*40</p> <p>P × 2</p> |  <p>M6*35</p> <p>Q × 8</p> |  <p>R × 1</p> |
|  <p>S × 1</p> |  <p>T × 4</p> |  <p>Tu × 1</p> |
|  <p>V × 2</p> |  <p>L × 4</p> | |

ÉTAPES D'ASSEMBLAGE

ÉTAPE 1 Pied installation

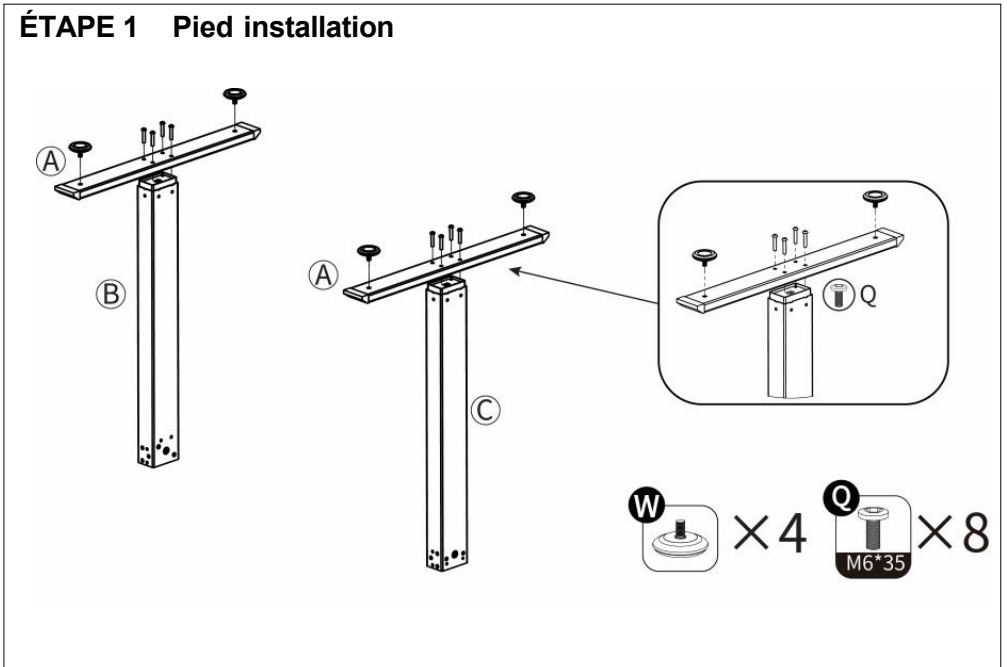

ÉTAPE 2 Installation du moteur

①

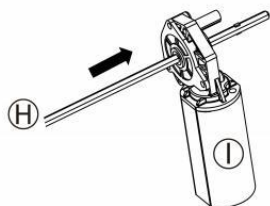

First, insert the motor from the end of the hexagonal rod without a bump to the other end with a bump.

②

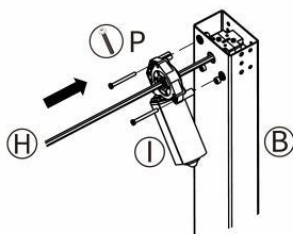

Then, insert the convex end of the motor into leg B together with the motor. Tighten the motor on leg B with the screws shown in the picture.



ÉTAPE 3 Conduire tige installation

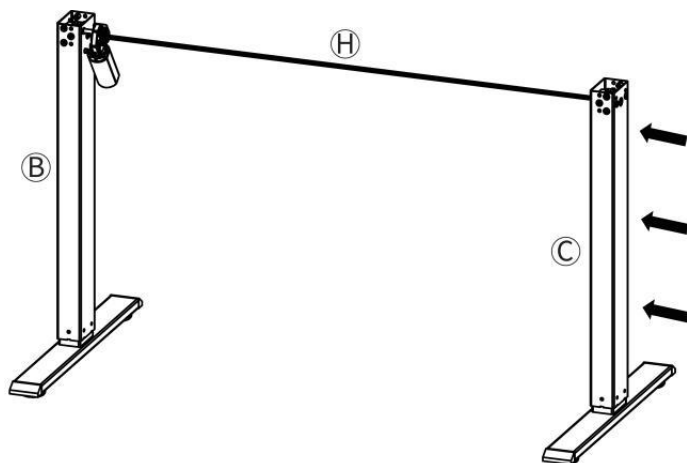

After completing the previous step, insert leg C into the hex stick.



If the holes are misaligned, hold the motor by hand and adjust the hex rod to rotate slightly so that the hex rod can be inserted into leg C.

ÉTAPE 4 Faisceau installation

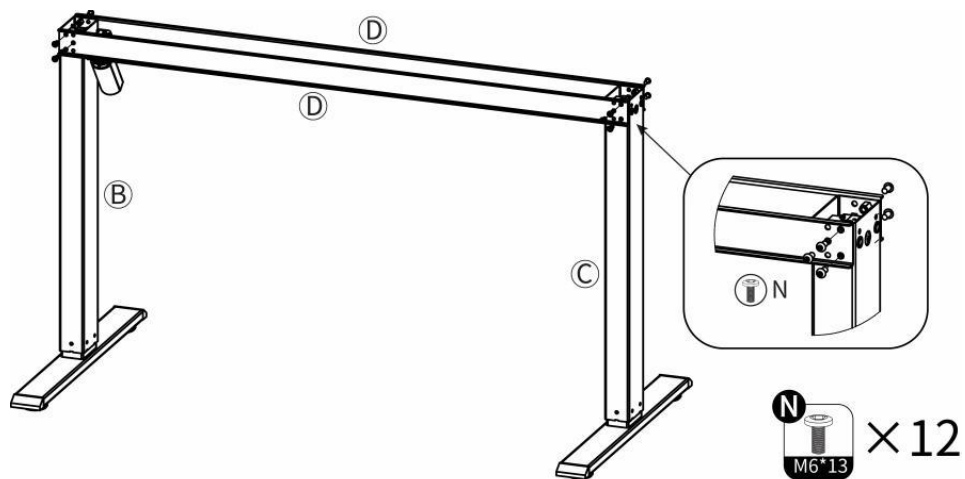

ÉTAPE 5 Installation d'ailes latérales

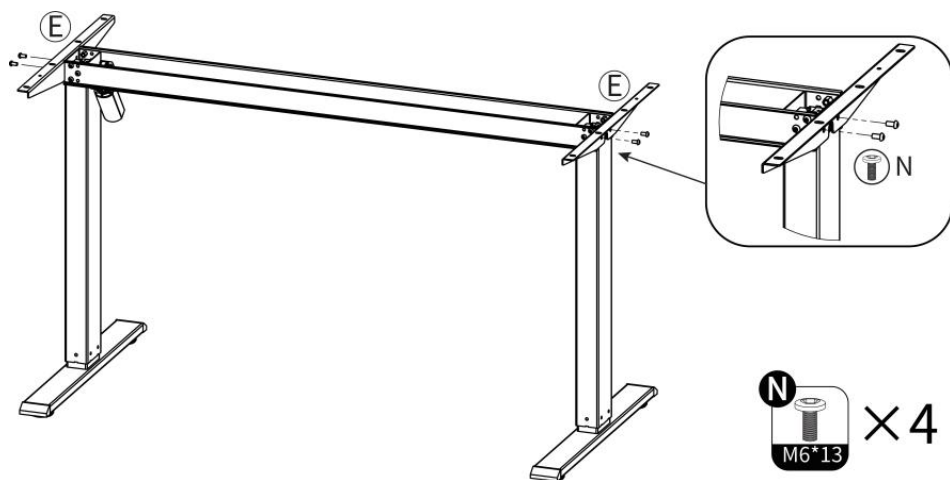

ÉTAPE 6 Raccordement du panneau (1)

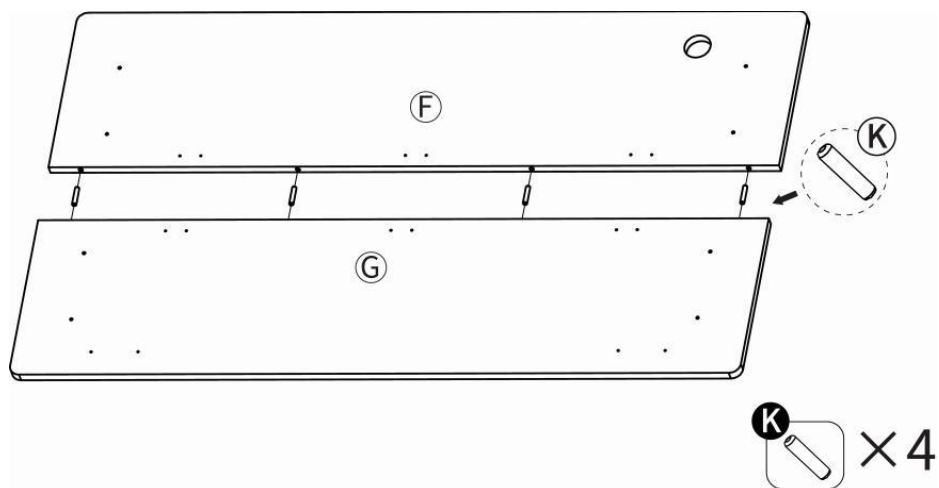

ÉTAPE 6 Raccordement de panneaux (2)

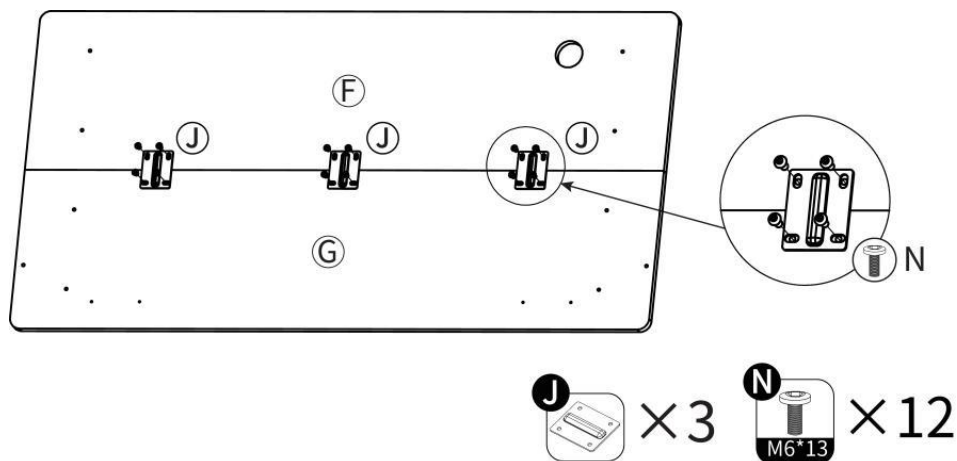

ÉTAPE 7 panneau installation

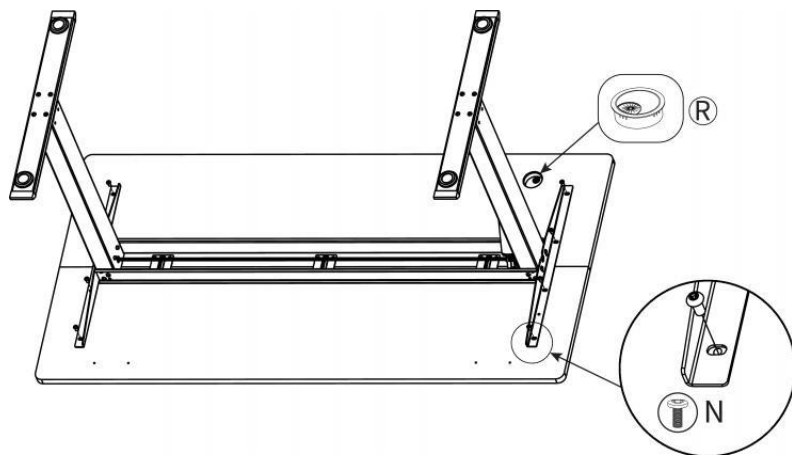

R × 1 **N** × 8
M6*13

ÉTAPE 8 Accessories installation

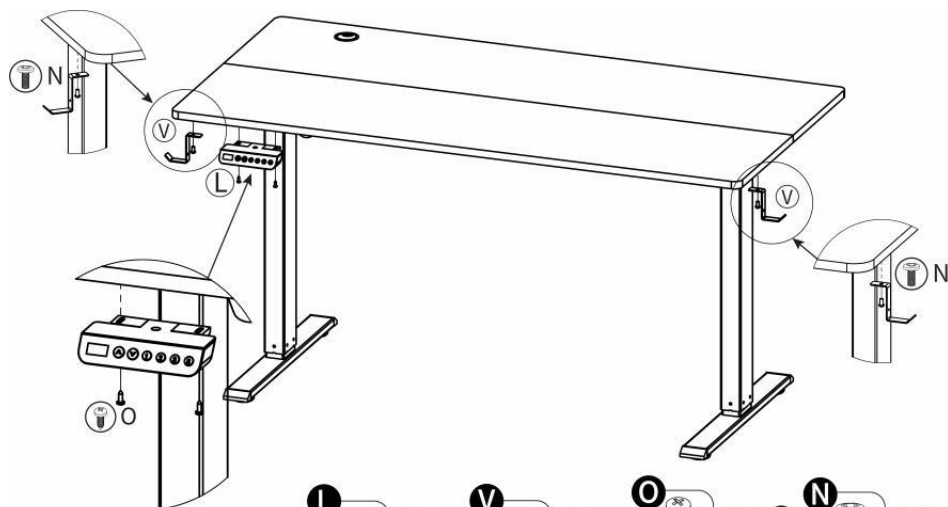

L × 1 **V** × 2 **O** × 2 **N** × 2
ST4*12 M6*13

ÉTAPE 9 Connexion de ligne

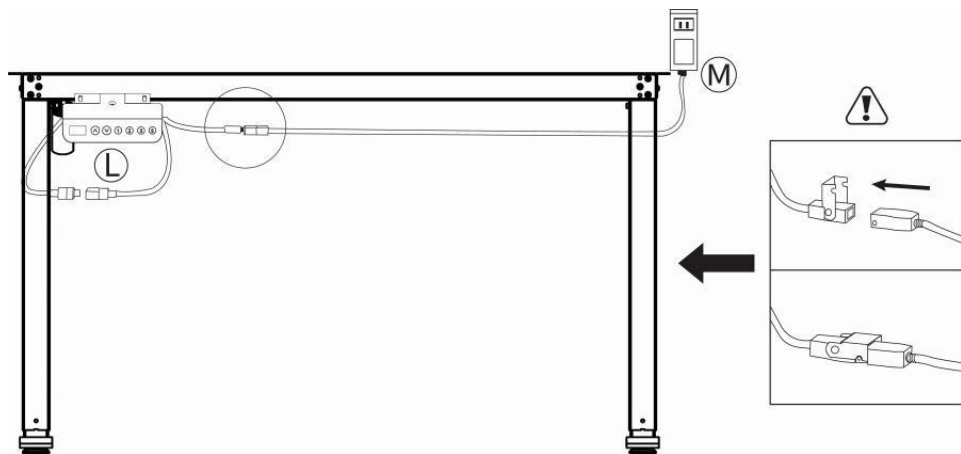

Height Adjustment Controller Operation

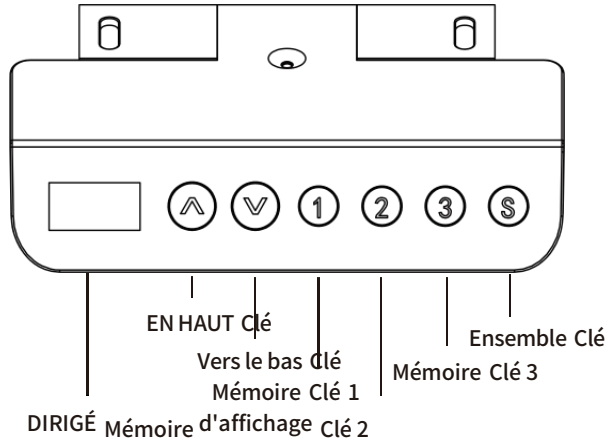

- LED Display:
Press any key once to wake up the LED display.
- UP Key: Press and hold the UP key to raise the desk.
- Down Key: Press and hold the DOWN key to lower the desk.
- Memory Key:

Toi doit complet le Initialisation Processus à réinitialiser ton bureau avant en utilisant il pour le premier temps.

Détaillé introduction de fonctions clés

Réinitialiser

Après courir vers le le plus bas hauteur position, presse et maintenez pendant 7 secondes. Lorsque le DIRIGÉ écran "premier" et Flash « E-1 » alternativement, relâchez le ↓ clé, et presse et tenir le clé encore. Après le bureau court jusqu'à la le plus bas zéro mécanique pointer, aller dos 5 mm, le DIRIGÉ écran affiche le le plus bas valeur de hauteur , et le réinitialiser est terminé.

Ensemble mémoire hauteur +

Appuyez sur le S appuyez une fois sur la touche, et le la valeur de la hauteur sera commencer clignotant. À ce temps, presse le 1, 2, et 3 touches pour sauvegarder le courant hauteur à la correspondant position.

Exécuter mémoire hauteur

Dans état normal, appuyez sur le nombre touche pour appeler en haut son correspondant hauteur, et le levage tableau volonté automatiquement courir vers le correspondant position.

Verrouillage clé (S)

Presse et maintenez le S pendant 3 secondes. Lorsque le DIRIGÉ écran affiche "ENSEMBLE", apprendre à ouvrir le S clé. Appuyez sur le nombre touche 3 pour entrer dans le écran de verrouillage État. À ce temps, le DIRIGÉ écran clignote et affiche "DÉSACTIVÉ".

Lorsque l'écran est fermé, presse et maintenez le S touche pour 3s, et le DIRIGÉ écran affiche le hauteur valeur. À ce moment-là, relâchez le S clé de compléter le déverrouillage.

Restaurer les paramètres d' usine (S)

Presse et maintenez le S touche pendant 9 secondes, libérer le S clé quand le DIRIGÉ écran affiche "FAC", et exploiter le S clé encore une fois à restaurer le usine paramètres.

Erreur Code Instructions

| Erreur Code | Raison | Solution |
|-------------|--|--|
| Se tromper | Se tromper est affiché lorsque le communication séquence de lignes entre les manuel contrôler et le contrôle boîte est faux | / |
| E-1 | Lorsque le système fait pas sauver le actuel position , le L'écran LED clignote alternativement à afficher "E-1" | Réinitialiser par en appuyant sur la long clé jusqu'à ce que le Écran LED affiche le minimum hauteur et le alarme est libéré |
| E-2 | Lorsque le moteur est verrouillé, le DIRIGÉ affiche E-2 | / |
| E-5 | Lorsque le moteur apparaît : le de liaison doubler est déconnecter-ed/desserré, le Écran LED clignote en alternance à afficher "E-5" | 1. Vérifiez le connexion lignes entre tous moteurs et le contrôleur à assurez - vous que ils sont fermes, et puis réinitialiser par long en appuyant sur la vers le bas clé jusqu'à ce que le Écran LED affiche le minimum hauteur, et retirer le alarme |
| au revoir | Lorsque le charger dépasse le s et valeur, la L'écran LED clignote à afficher ovr. À ce moment-là, il est nécessaire à enlever le poids de la bureau et pouvoir sur le contrôleur après alimenter off. Ceci alarme peut être soulagé | 1. Normale la charge doit être contrôlé ci-dessous 120 kg 2. Lorsque le actuel dépasse 4A, le surcharge la fonction de protection sera être déclenché |

| | | |
|-------|---|---|
| chaud | Lorsque le température interne ture de la contrôleur dépasse 60 ± 5 degrés, le DIRIGÉ affiche chaud | / |
|-------|---|---|

| | | |
|-------|---|---|
| voL | Lorsque la tension d'entrée de la le contrôleur dépasse 34 V, le DIRIGÉ affiche voL | <ol style="list-style-type: none"> 1. Lorsque la tension dépasse 32 V, le contrôleur est alimenté et le DIRIGÉ écran est noir; 2. Lorsque la tension tombe à 32V, le le système va automatiquement répondre et LDE volonté afficher le temps réel hauteur |
| chaud | Après le moteur s'exécute continue- pendant 5 minutes, le DIRIGÉ écran affiche chaud, et il peut fonctionner normalement après avoir attendu 10 minutes | <ol style="list-style-type: none"> 1. Ininterrompu opération signifie que le opération intervalle est dans les 3 secondes 2. Ceci alarme peut aussi être supprimé lorsque le Système de contrôle est alimenté sur encore |
| E-3 | Pendant l'opération, quand soudainement bloqué, le DIRIGÉ l'écran clignote "E-3", arrête le action et 30 mm de longueur dans le opposé direction, puis le Écrans LED le en temps réel hauteur | Il doit être assuré que la table volonté pas vibrer de manière significative, bosse dans obstacles ou incliner pendant opération |

ACHÈVEMENT

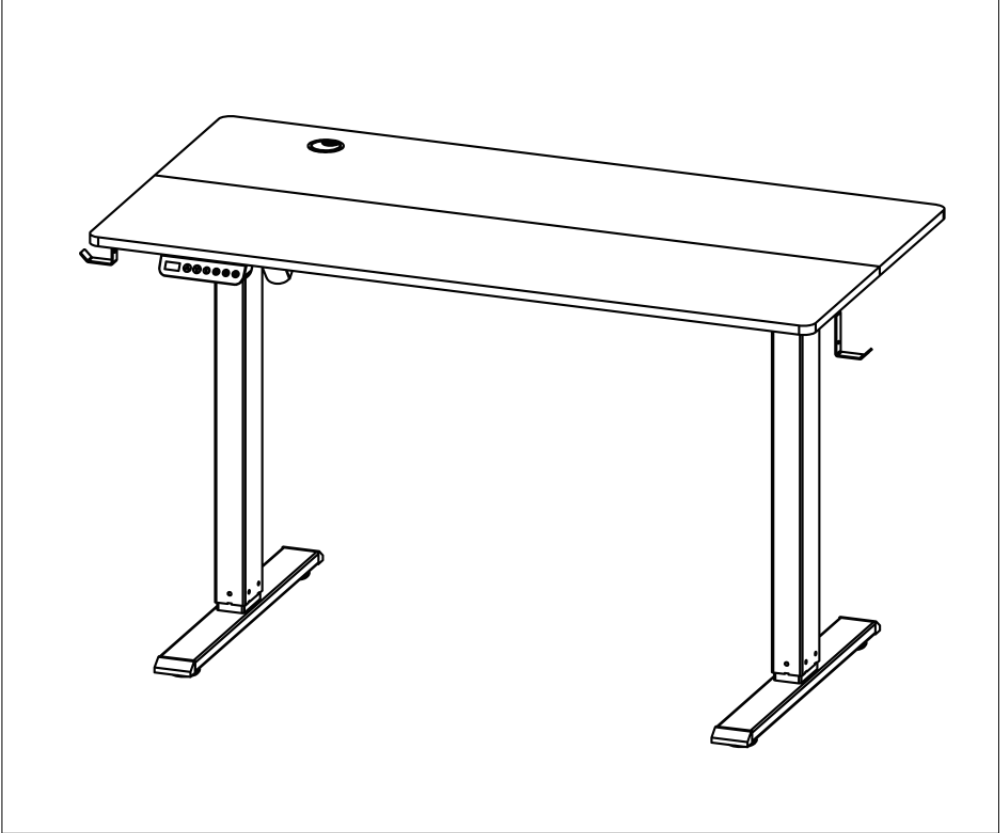

Adresse : Shuangchenglu 803nong11hao1602A-1609shi, baoshanqu,
Shanghai 200 000 CN.

Importé à États-Unis : Sanven Technologie Ltée . , suite 250 , 9166 Anaheim
lieu, Rancho cucamonga, CA 91730

| | |
|-----------|------------|
| EC | REP |
|-----------|------------|

E-CrossStu GmbH.

Rue Mainzer Landstr.69, 60329 Francfort am
Principal.

| | |
|-----------|------------|
| UK | REP |
|-----------|------------|

YH CONSULTING LIMITÉ.

C/OYH Consulting Bureau à responsabilité limitée 147,
Centurion Maison, Londres Route, Staines-upon-
Thames, Surrey, TW184AX

VEVOR[®]

TOUGH TOOLS, HALF PRICE

Support technique et Certificat de garantie
électronique www.vevor.com/support

VEVOR[®]

TOUGH TOOLS, HALF PRICE

Technisch Ondersteuning en E-garantie certificaat

<https://www.vevor.com/support>

OPHEFFEN VLAK TAFEL GEBRUIKER HANDMATIG

Wij blijven ons inzetten voor u ook voorzien van concurrerende prijs.

"Redden Half", "halve prijs" of andere soortgelijke uitdrukkingen die worden gebruikt door ons alleen vertegenwoordigt een schatting van de besparingen die u kunt behalen door bepaalde gereedschappen bij ons te kopen in vergelijking met de grote

topmerken en betekent niet per se dat omslag alle categorieën van de aangeboden hulpmiddelen door wij. Jij

Zijn vriendelijk herinnerd om zorgvuldig te controleren wanneer u een bestelling plaatsent bij ons als je bent

Eigenlijk besparen de helft vergeleken met de grote topmerken.

VEVOR®

TOUGH TOOLS, HALF PRICE

Tillen Platte tafel

MODEL NR .: ZWE - DDJ - SS -01, ZWE - DDJ - SS -02, ZWE - DDJ - SS -03,
ZWE - DDJ - SS -04, ZWE - DDJ - SS -05, ZWE - DDJ - SS -06, ZWE -
DDJ - SS -07 ZWE - DDJ - SS -08

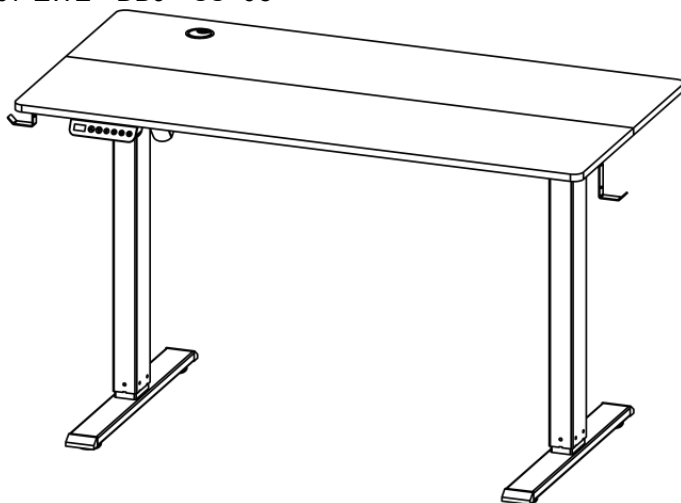

NEED HELP? CONTACT US!

Hebben product vragen? Behoeft technische steun? Alsjeblieft gevoel vrij naar

contact wij: **Technisch Steun En E-Garantie Certificaat**
www.vevor.com/support

Dit is het origineel instructie, Alsjeblieft lees alles handmatig instructies voorzichtig voor gebruik. VEVO R behoudt zich een duidelijke interpretatie voor van onze gebruikershandleiding. Het uiterlijk van het product zal zijn onderwerp naar de product jij ontvangen. Vergeef me alsjeblieft ons dat we niet zullen u opnieuw informeren als er technologie of software is updates over onze product.



WAARSCHUWING:

Alsjeblieft lees dit handleiding zorgvuldig voor het gebruik van het product. Het niet slagen van doe dat kan resulteren in ernst letsel. BEWAAR DIT IS HANDMATIG

MONTAGEVOORZORGSMATREGELEN

1. Monteer het geheel uitsluitend volgens deze instructies. Onjuiste montage kan creëren gevaren.
2. Dragen ANSI-goedgekeurde veiligheidsbrillen en robuuste werkhandschoenen tijdens de montage.
3. Houd het montagegebied schoon schoon en goed verlicht.
4. Houd omstanders uit de buurt houden tijdens de bijeenkomst.
5. Do niet monteren als je moe bent of als onder invloed van alcohol, medicijnen, of medicatie.
6. De productmogelijkheden zijn van toepassing op de juiste en volledig geassembleerd alleen producten.
7. Monteer op een vlakke, waterpas, hard en glad oppervlak geschikt van veilig ondersteunen van de Tillen Platte tafel .
8. Voor extra informatie betreffende de vermelde onderdelen in de volgende vleugel pagina's, alstublieft verwijzen naar de Montage Schema van deze handleiding. Uitpakken en scheid alles onderdelen op een duidelijk werk gebied.

GEBRUIK VOORZORGSMATREGELEN

OM ERNSTIGE BLESSURE EN DOOD VAN FOOIEN:

1. Dit product is geen speelgoed. Doen niet toestaan kinderen naar toneelstuk met of benadering dit item.
2. Alleen gebruiken zoals bedoeld. Doen niet zitten of stelling op de tafel.









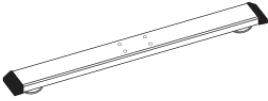
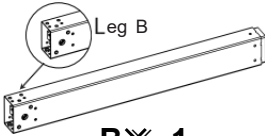
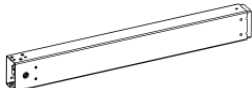

3. Inspect voor elk gebruik. Niet doen gebruik Het als onderdelen Zijn los of beschadigd. Alleen gebruiken op vlakke, vlakke, En moeilijk oppervlakken .

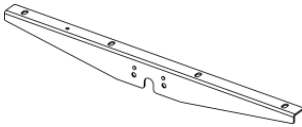



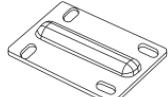

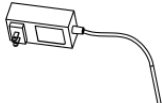

TECHNISCHE SPECIFICATIES

| Model | ZWE-DDJ-SS-01 ZWE-DDJ-SS-02 | ZWE-DDJ-SS-03 ZWE-DDJ-SS-04 |
|----------------------------|--------------------------------|--------------------------------|
| Adapterclassificatie (s) | 100-240V~, 50/60Hz, 1.5A | |
| Voornaamst Materiaal | Staal + Bord | Staal + Bord |
| Kleur | Bruin + Zwart | Bruin + Zwart |
| Product Afmetingen (LxBxH) | 1200x600x 1145 mm | 1200x800 X 1145 mm |
| Verpakking Maat (LxBxH) | 1295x395 X 120 mm | 1295x495x 120 mm |
| Netto gewicht (kg) | 21.8 | 25.2 |
| Brutogewicht (kg) | 24.5 | 27.9 |

| Model | ZWE-DDJ-SS-05 ZWE-DDJ-SS-06 | ZWE-DDJ-SS-07 ZWE-DDJ-SS-08 |
|----------------------------|--------------------------------|--------------------------------|
| Adapterclassificatie (s) | 100-240V~, 50/60Hz, 1.5A | |
| Voornaamst Materiaal | Staal + Bord | Staal + Bord |
| Kleur | Bruin + Zwart | Bruin + Zwart |
| Product Afmetingen (LxBxH) | 1400x600x 1145 mm | 1400x700x 1145 mm |
| Verpakking Maat (LxBxH) | 1493x405x 120 mm | 1490x455x 120 mm |
| Netto gewicht (kg) | 23.2 | 24.9 |
| Brutogewicht (kg) | 26.1 | 27.9 |

INHOUD VAN HET PAKKET

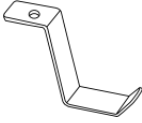
| | | |
|---|--|---|
|  <p>A × 2</p> |  <p>B × 1</p> |  <p>C × 1</p> |
|  <p>D × 2</p> | |  <p>Ik × 2</p> |
|  <p>F × 1</p> |  <p>G × 1</p> | |
|  <p>H × 1</p> | |  <p>Ix × 1</p> |
|  <p>J × 3</p> |  <p>Ik × 4</p> |  <p>Ikk × 1</p> |
|  <p>M × 1</p> |  <p>N × 38 M6*13</p> |  <p>O × 2 ST 4*12</p> |

| | | |
|--|---|---|
|  <p>M4*40</p> <p>P × 2</p> |  <p>M6*35</p> <p>Q × 8</p> |  <p>R × 1</p> |
|  <p>S × 1</p> |  <p>T × 4</p> |  <p>Ik × 1</p> |
|  <p>V × 2</p> |  <p>W × 4</p> | |

MONTAGESTAPPEN

STAP 1 Voet installatie

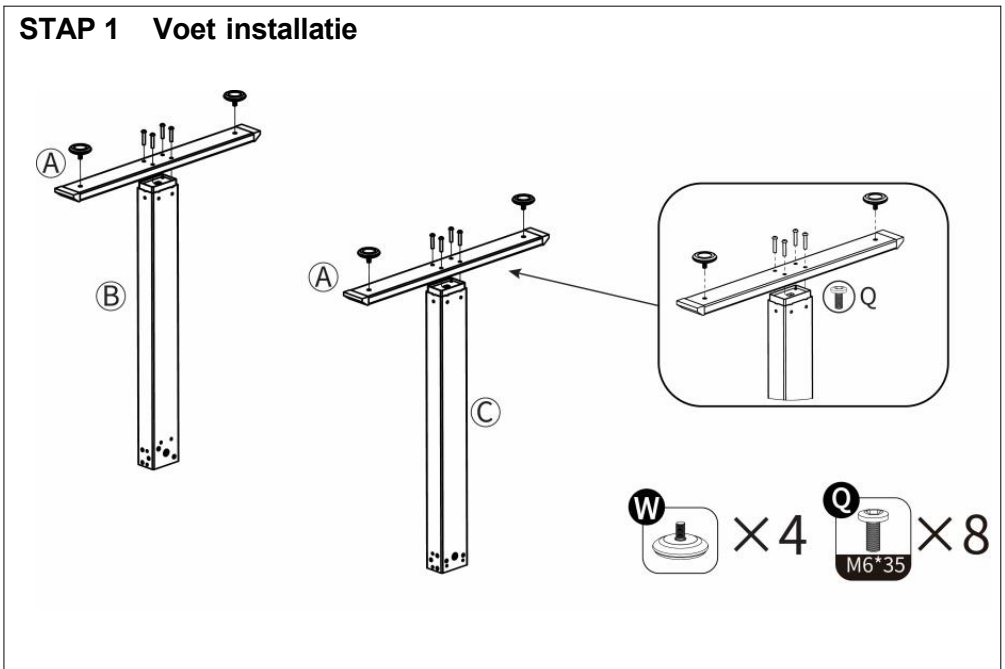

STAP 2 Motorinstallatie

①

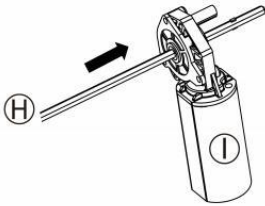

First, insert the motor from the end of the hexagonal rod without a bump to the other end with a bump.

②

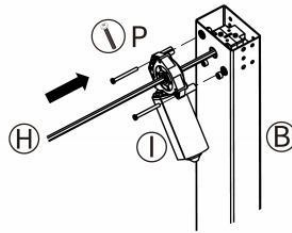

Then, insert the convex end of the motor into leg B together with the motor. Tighten the motor on leg B with the screws shown in the picture.



STAP 3 Drijfveer hengel installatie

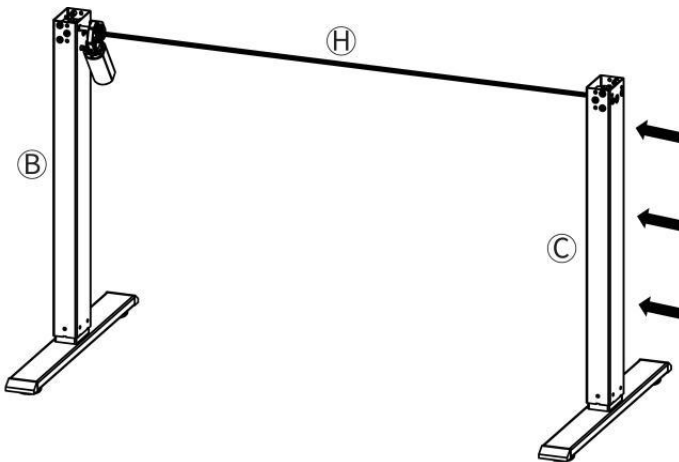

After completing the previous step, insert leg C into the hex stick.



If the holes are misaligned, hold the motor by hand and adjust the hex rod to rotate slightly so that the hex rod can be inserted into leg C.

STAP 4 Straal installatie

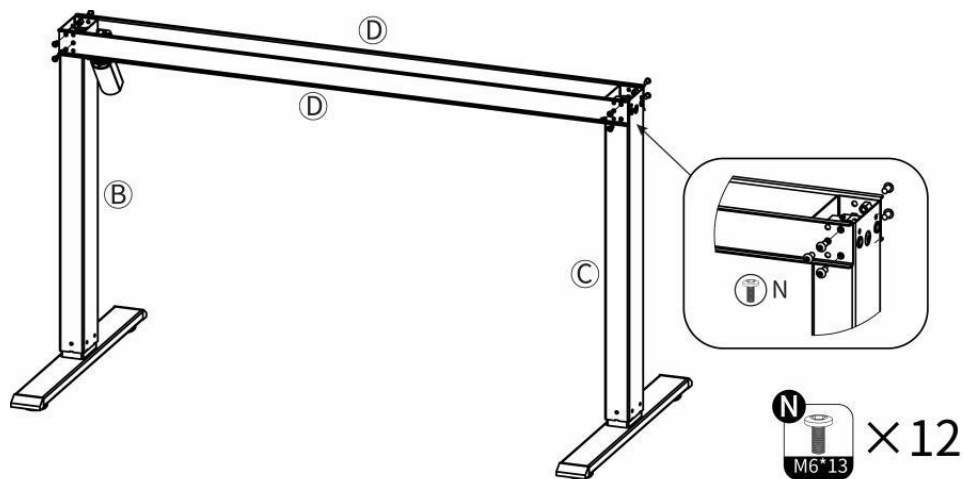

STAP 5 Installatie van zijvleugels

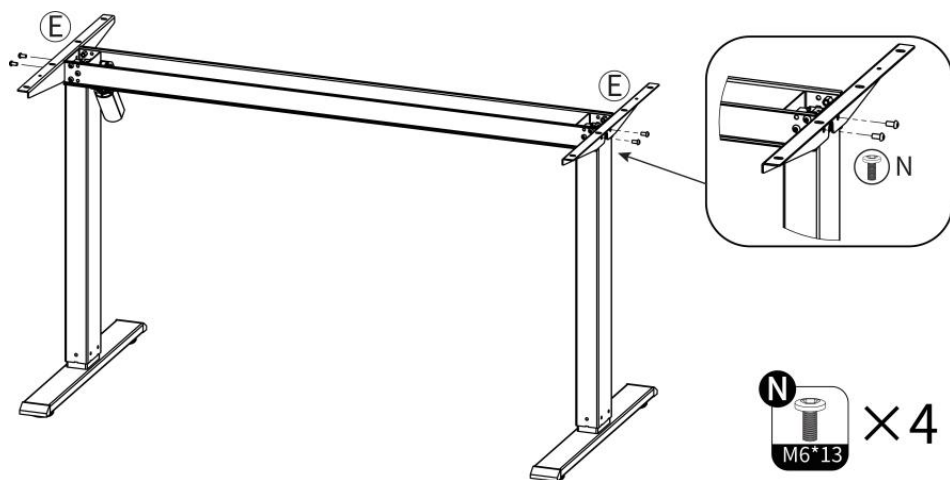

STAP 6 Paneelverbindingen (1)

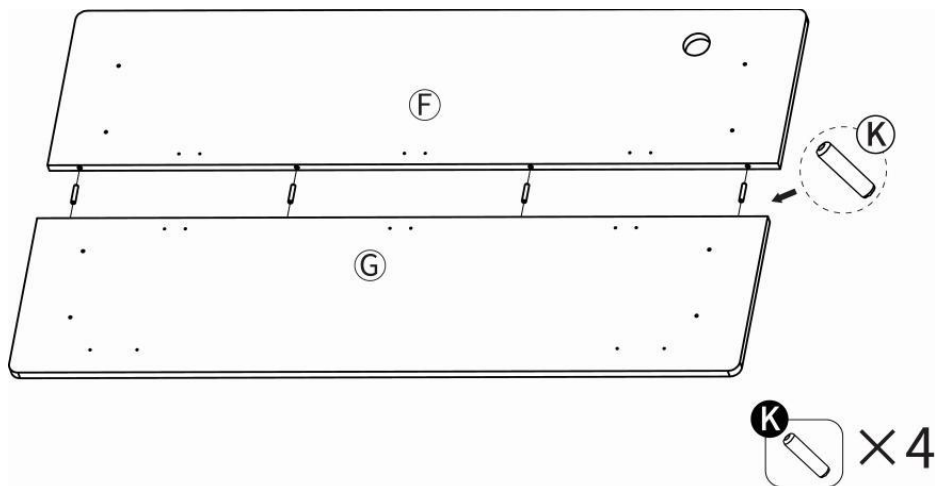

STAP 6 Paneelverbinding (2)

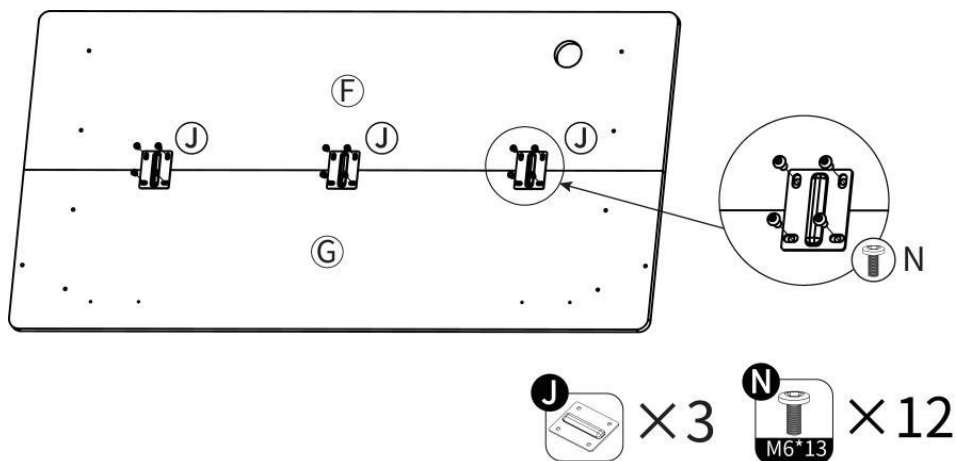

STAP 7 paneel installatie

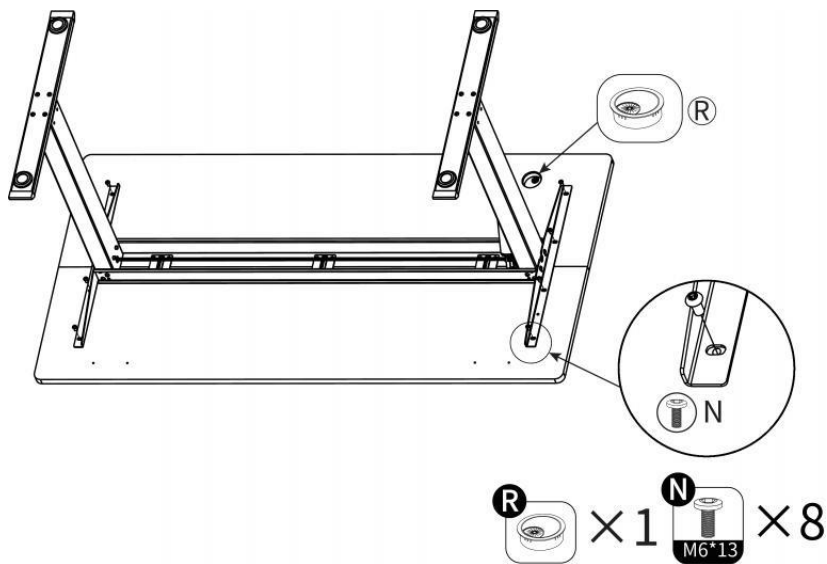

STAP 8 Accessories installation

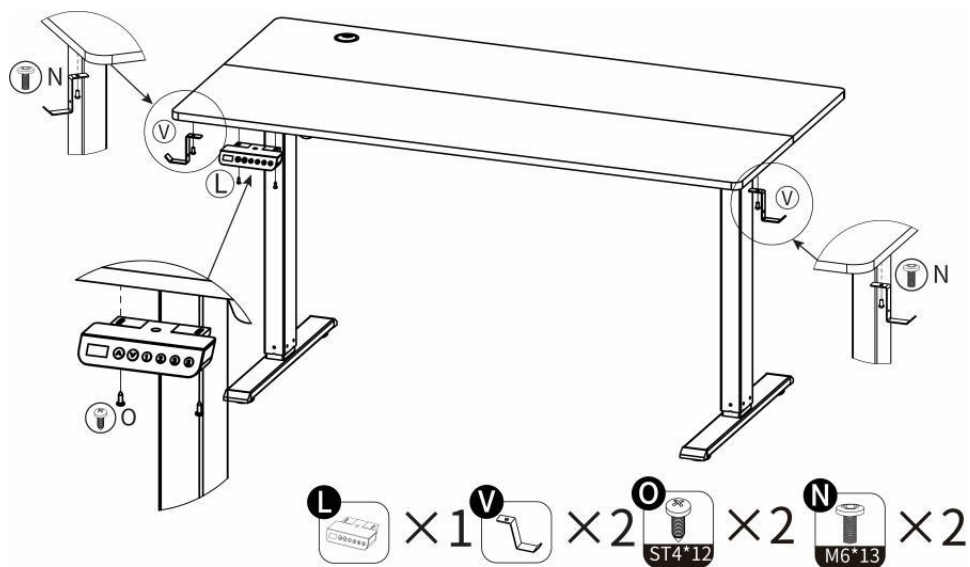

STAP 9 Lijnverbinding

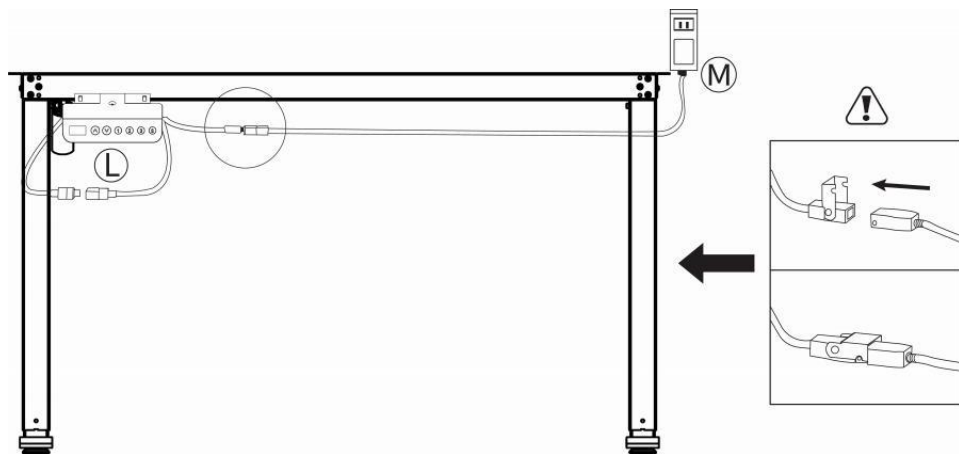

Height Adjustment Controller Operation

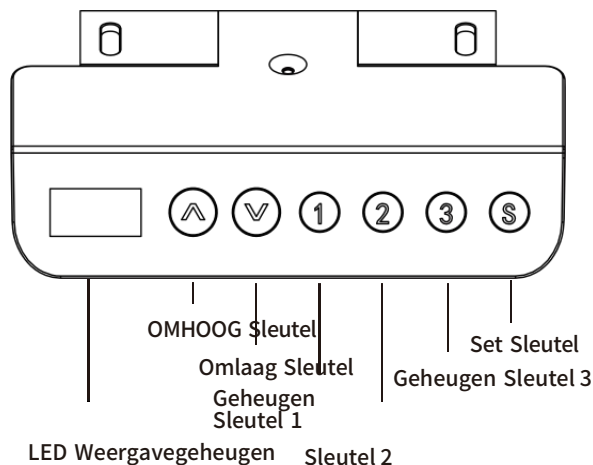

- LED Display:
Press any key once to wake up the LED display.
- UP Key: Press and hold the UP key to raise the desk.
- Down Key: Press and hold the DOWN key to lower the desk.
- Memory Key:



Jij moeten compleet de Initialisatie Proces naar opnieuw instellen jouw bureau voor gebruik makend van Het voor de eerste tijd.

Gedetailleerd introductie van belangrijkste functies

Opnieuw instellen

Na rennen naar de laagste hoogte positie, pers En 7 seconden vasthouden . Wanneer de LED scherm "eerste" En "E-1" flitser afwisselend, laat de ↓ los sleutel, En pers En houd de sleutel opnieuw. Na de bureaublad loopt naar beneden naar de laagste mechanische nul punt, ga rug 5 mm, de LED scherm beeldschermen de laagste hoogtewaarde , en de opnieuw instellen is voltooid.

Set geheugen hoogte +

Druk op de S sleutel eenmaal, en de hoogtewaarde zal begin knipperend. Bij dit tijd, pers de 1, 2, En 3 toetsen om de huidige op te slaan hoogte tot de overeenkomstig positie.

Uitvoeren geheugen hoogte

In normale toestand, druk op de nummer sleutel om te bellen omhoog de bijbehorende hoogte, En de opheffen tafel zullen automatisch ren naar de overeenkomstige positie.

Slot sleutel (S)

Pers En houd de S vast toets 3 seconden ingedrukt. Wanneer de LED scherm beeldschermen "SET", leren naar open de S sleutel. Druk op de nummer toets 3 om de vergrendelscherm staat. Bij dit tijd, de LED scherm flitsen en toont "UIT".

Wanneer het scherm is vergrendeld, pers En houd de S vast sleutel voor 3s, En de LED scherm beeldschermen de hoogte waarde. Op dit moment, laat de S los sleutel tot voltooi de ontgrendelen.

Fabrieksinstellingen herstellen (S)

Pers En houd de S vast toets 9 seconden ingedrukt houden, uitgave de S sleutel wanneer de LED scherm beeldschermen "VOORKEUR", en bedien de S sleutel opnieuw naar herstellen de fabriek instellingen.

Fout Code Instructies

| Fout Code | Reden | Oplossing |
|-----------|---|---|
| Eh | Eh is weergegeven wanneer de mededeling lijnvolgorde tussen de handmatig controle - leer en de controle doos is fout | / |
| E-1 | Wanneer het systeem doet niet bewaar de huidig positie , de LED-scherm knippert afwisselend naar weergave "E-1" | Opnieuw instellen door door op de lang sleutel tot de LED-scherm toont de minimaal m hoogte en de alarm is uitgegeven |
| E-2 | Wanneer de motor is vergrendeld, de LED beeldschermen E-2 | / |
| E-5 | Wanneer de motor verschijnt: de verbinden lijn is loskoppelen- losgemaakt/verlost, de LED-scherm flitsen afwisselend naar weergave "E-5" | 1. Controleer de verbinding lijnen tussen alle motoren en de controller naar en ervoor zorgen dat zij zijn stevig, en de n opnieuw instellen door lang door op de omlaag sleutel tot de LED-scherm toont de minimum hoogte, En verwijderen de alarm |
| over | Wanneer de laden overschrijdt de set waarde, de LED-scherm knippert naar weergave ovr. Op dit moment, Het is noodzakelijk om verwijder de w acht van de bureaublad En stroom op de regelaar na aandrijven uit. Dit alarm kan zijn opgelucht | 1. Normaal laden zal zijn gecontroleerd onderstaand 120KG 2. Wanneer de huidig overschrijdt 4A, de overbelasting beschermingsfunctie zal zijn geactiveerd |

| | | |
|------|---|---|
| heet | Wanneer de interne temperatuur tuur van de regelaar overschrijdt 60 ± 5 graden, de LED beeldschermen heet | / |
|------|---|---|

| | | |
|------|---|---|
| vol | Wanneer de ingangsspanning van de controller overschrijdt 34V, de LED geeft vol weer | <ol style="list-style-type: none"> 1. Wanneer de spanning overschrijdt 32V, de regelaar is aangedreven uit en de LED scherm is zwart; 2. Wanneer de spanning daalt naar 32V, de systeem zal automatisch antwoord En LDE zullen de echte tijd hoogte |
| heet | Na de motor loopt doorgaangedurende 5 minuten, de LED scherm beeldschermen heet, En Het kan werken normaal gesproken na het wachten op 10 minuten | <ol style="list-style-type: none"> 1. Ononderbroken operatie betekent dat de operatie interval is binnen 3s 2. Dit alarm kan Ook zijn verwijderd wanneer de controlesysteem is aangedreven op opnieuw |
| E-3 | Tijdens de operatie, wanneer plotseling geblokkeerd, de LEID scherm flitst "E-3", stopt de actie En loopt 30mm in de tegenovergestelde richting, dan de LED-schermen weergeven de realtime hoogte | Het zal zijn ervoor gezorgd dat de tafel zullen niet trillen aanzienlijk, buil naar binnen obstakels of kantelen tijdens operatie |

VOLTOOIING

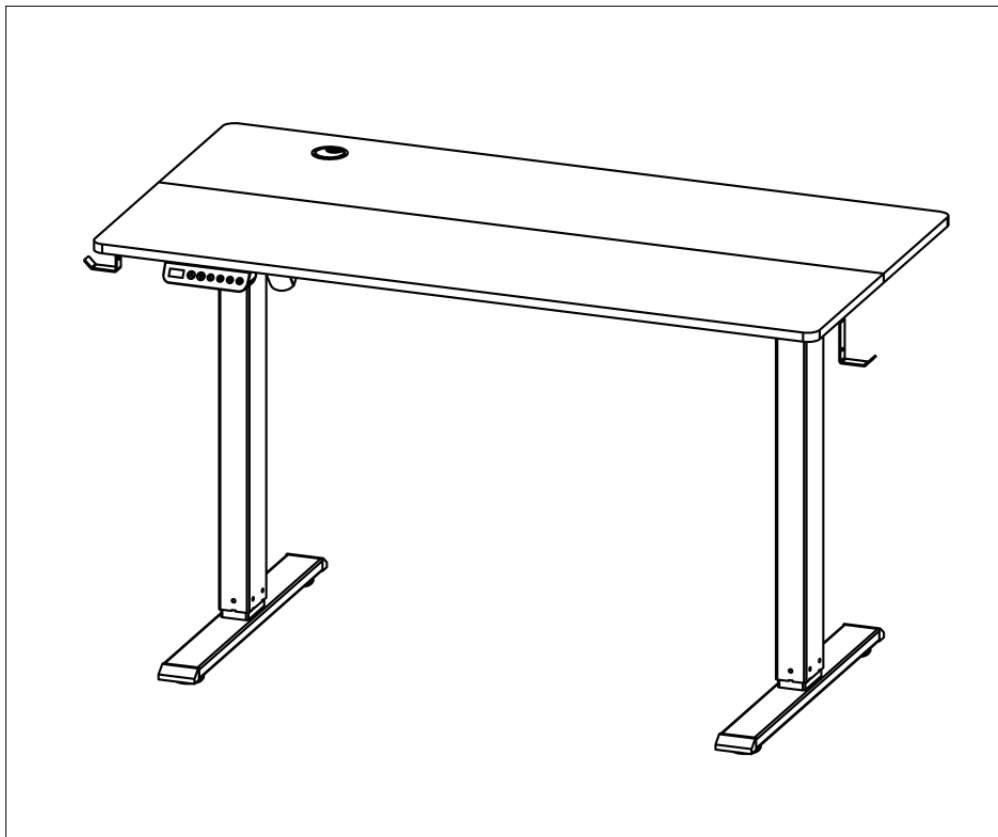

Adres: Shuangchenglu 803nong11hao1602A-1609shi, baoshanqu,
Sjanghai 200000 CN.

Geïmporteerd naar Verenigde Staten : sanven Technologie BV ., suite 250 ,
9166 Anaheim plaats, Rancho komkommer, CA -91730

| | |
|-----------|------------|
| EC | REP |
|-----------|------------|

E-CrossStu GmbH.

Mainzer Landstr.69, 60329 Frankfurt am
Voornaamst.

| | |
|-----------|------------|
| UK | REP |
|-----------|------------|

YH-CONSULTING BEPERKT.

C/OYH-advies Beperkt kantoor 147, Centurio Huis,
Londen Weg, Staines-upon-Thames, Surrey, TW184AX

VEVOR[®]

TOUGH TOOLS, HALF PRICE

Technische ondersteuning en E- Garantie
Certificaat www.vevor.com/support

VEVOR®

TOUGH TOOLS, HALF PRICE

Teknisk Support och E-garanticertifikat <https://www.vevor.com/support>

LYFTPLATTA TABELL ANVÄNDARE MANUELL

Vi fortsätter att vara engagerade i ge dig också konkurrenskraftiga pris.

"Spara Halva, "Halva priset" eller andra liknande uttryck som används av oss endast representerar en

uppskattning av besparingar du kan dra nytta av att köpa vissa verktyg hos oss jämfört med de större

toppmärken och betyder inte nödvändigtvis att täcka alla kategorier verktyg som erbjuds av oss. Du

är vänligen påmind om att kontrollera noggrant när du är lägga en beställning med oss om du är det

faktiskt sparar hälften i jämförelse med de främsta stora varumärkena.

VEVOR®

TOUGH TOOLS, HALF PRICE

Lyft Platt bord

MODELL NR .: ZWE - DDJ - SS -01, ZWE - DDJ - SS -02, ZWE - DDJ - SS -03,
ZWE - DDJ - SS -04, ZWE - DDJ - SS -05, ZWE - DDJ - SS -06, ZWE -
DDJ - SS -07 ZWE - DDJ - SS -08

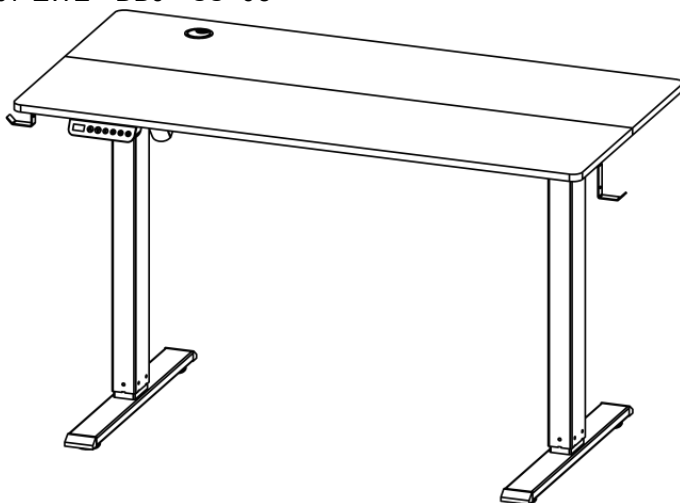

NEED HELP? CONTACT US!

Ha produkt frågor? Behov teknisk stöd? Behaga känsla gratis till
kontakta oss: **Tekniskt Stöd och E-garanti Certifikat**
www.vevor.com/support

Detta är originalet instruktion, behaga re annons alla manuell
instruktioner

försiktigt före drift. VEVO R reserverar sig för en tydlig tolkning i vår
bruksanvisning. Produktens utseende ska vara ämne till
produkt dig mottagen. Snälla förlåt oss att vi inte kommer informera dig
igen om det finns någon teknik eller programvara uppdateringar på vår
produkt.



VARNING:

**Behaga läs detta handbok noggrant före med hjälp av produkten .
Underlåtenhet att gör så kan bli resultatet på allvar skada. SPARA
DET HÄR MANUELL**

FÖRSIKTIGHETSÅTGÄRDER FÖR MONTERING

1. Montera endast enligt dessa instruktioner. Felaktig montering burk skapa faror.
2. Bära ANSI-godkända skyddsglasögon och kraftiga arbetshandskar under monteringen.
3. Behåll monteringsområdet rena och väl upplyst.
4. Behåll åskådare utanför området under monteringen.
5. Gör inte montera när du är trött eller när under påverkan av alkohol, droger, eller medicin.
6. De produktkapacitet gäller för korrekt och helt monterade endast produkter.
7. Montera på en plan, jämn, hård och slät yta kapabel av säkert stödja Lyft Platt bord.
8. För ytterligare information angående delarna som anges i följande flygel sidor, tack hänvisa till Montering Diagram över denna manual. Packa upp och separera alla delar på en tydligt arbete område.

ANVÄNDA FÖRSIKTIGHETSÅTGÄRDER

**FÖR ATT FÖRHINDRA ALLVARLIGA SKADA OCH DÖD FRÅN
TIPPNING:**

1. Detta produkt är inte en leksak. Do inte tillåta barn till spela med eller närma sig detta punkt.
2. Använd endast på avsett sätt. Do inte sitta eller stå på de tabell.









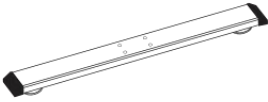
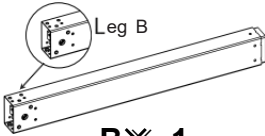
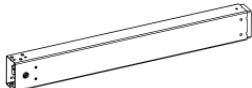

3. Inspektera före varje användning. Gör inte det använda det om delar är lös eller skadad. Använd endast på plana, plana, och hård ytor .

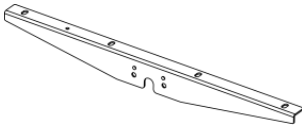



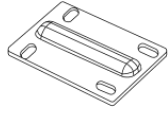

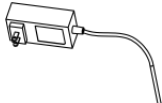

TEKNISKA SPECIFIKATIONER

| Modell | ZWE-DDJ-SS-01 ZWE-DDJ-SS-02 | ZWE-DDJ-SS-03 ZWE-DDJ-SS-04 |
|-----------------------------------|--------------------------------|--------------------------------|
| Adapterbetyg | 100-240V~, 50/60Hz, 1,5A | |
| Main Material | Stål + Styrelse | Stål + Styrelse |
| Färg | Brun + Svart | Brun + Svart |
| Produkt Mått (LxBxH) | 1200 x 600 x 1145 mm | 1200 x 800 x 1145 mm |
| Förpackning Storlek (LxBxH) | 1295 x 395 x 120 mm | 1295 x 495 x 120 mm |
| Nettovikt (kg) | 21.8 | 25.2 |
| Bruttovikt (kg) | 24.5 | 27,9 |

| Modell | ZWE-DDJ-SS-05 ZWE-DDJ-SS-06 | ZWE-DDJ-SS-07 ZWE-DDJ-SS-08 |
|-----------------------------------|--------------------------------|--------------------------------|
| Adapterbetyg | 100-240V~, 50/60Hz, 1,5A | |
| Main Material | Stål + Styrelse | Stål + Styrelse |
| Färg | Brun + Svart | Brun + Svart |
| Produkt Mått (LxBxH) | 1400 x 600 x 1145 mm | 1400 x 700 x 1145 mm |
| Förpackning Storlek (LxBxH) | 1493 x 405 x 120 mm | 1490 x 455 x 120 mm |
| Nettovikt (kg) | 23.2 | 24.9 |
| Bruttovikt (kg) | 26.1 | 27,9 |

PAKETETS INNEHÅLL

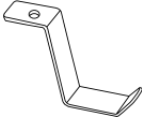
| | | |
|---|--|---|
|  <p>AX 2</p> |  <p>B 1</p> |  <p>C 1</p> |
|  <p>D 2</p> | |  <p>E 2</p> |
|  <p>F 1</p> |  <p>G 1</p> | |
|  <p>H 1</p> | |  <p>jag 1</p> |
|  <p>J 3</p> |  <p>K 4</p> |  <p>L 1</p> |
|  <p>M 1</p> |  <p>N 38 M6*13</p> |  <p>O 2 ST 4*12</p> |

| | | |
|--|---|--|
|  <p>M4*40</p> <p>P × 2</p> |  <p>M6*35</p> <p>F × 8</p> |  <p>R × 1</p> |
|  <p>S × 1</p> |  <p>T × 4</p> |  <p>U × 1</p> |
|  <p>V × 2</p> |  <p>W × 4</p> | |

MONTERINGSSEG

STEG1 Fot installation

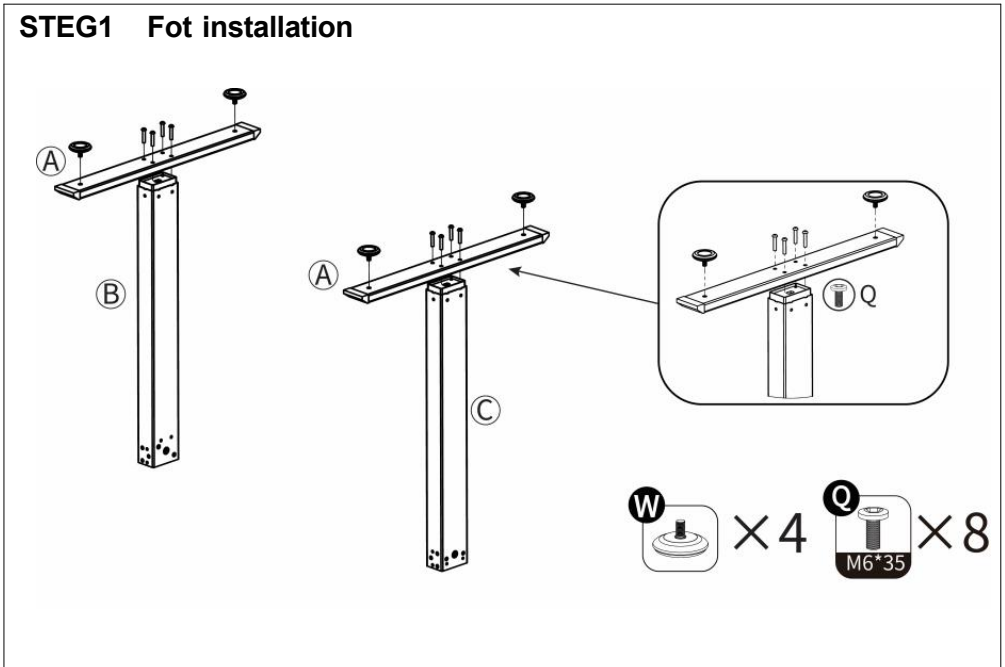

STEP 2 Motorinstallation

①

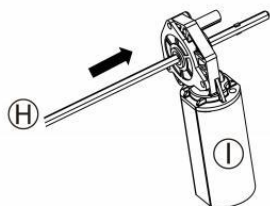

First, insert the motor from the end of the hexagonal rod without a bump to the other end with a bump.

②

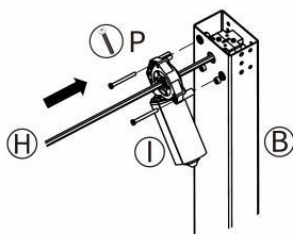

Then, insert the convex end of the motor into leg B together with the motor. Tighten the motor on leg B with the screws shown in the picture.



STEP 3 Köra stång installation

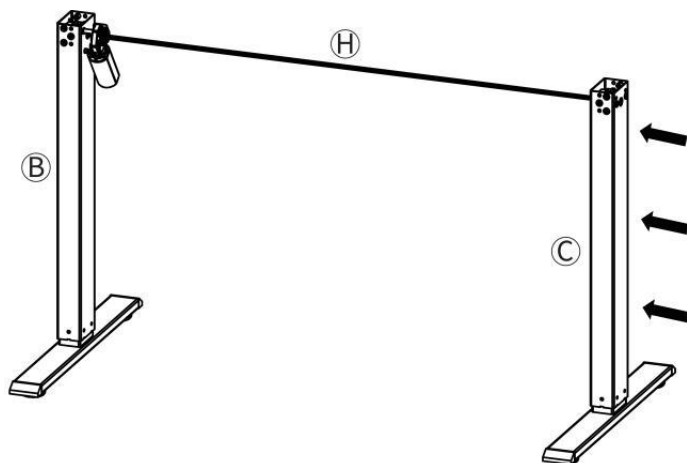

After completing the previous step, insert leg C into the hex stick.



If the holes are misaligned, hold the motor by hand and adjust the hex rod to rotate slightly so that the hex rod can be inserted into leg C.

STEG 4 Balk installation

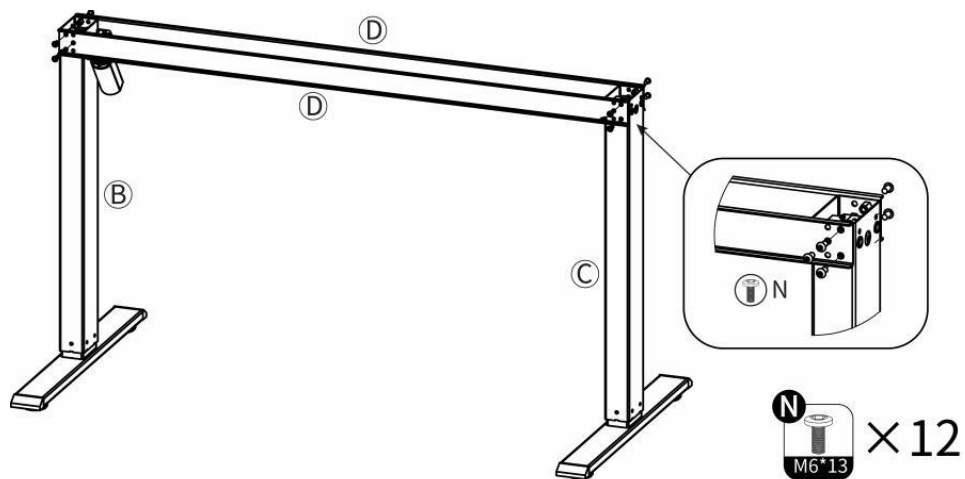

STEG 5 Installation av sidovingar

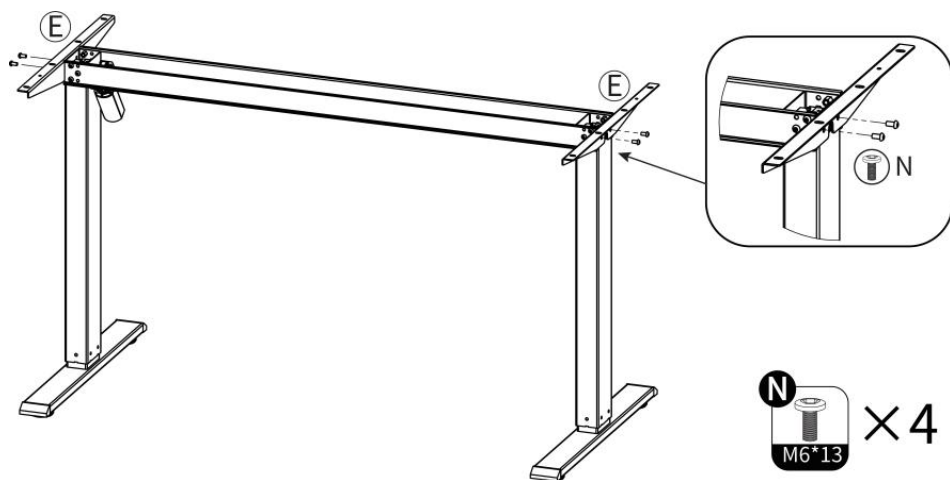

STEG6 Panelskarvning (1)

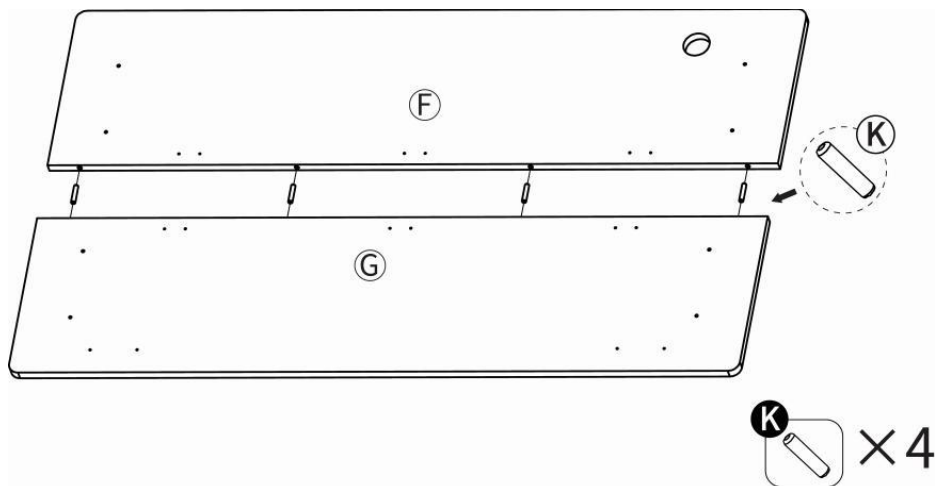

STEG 6 Panelskarvning (2)

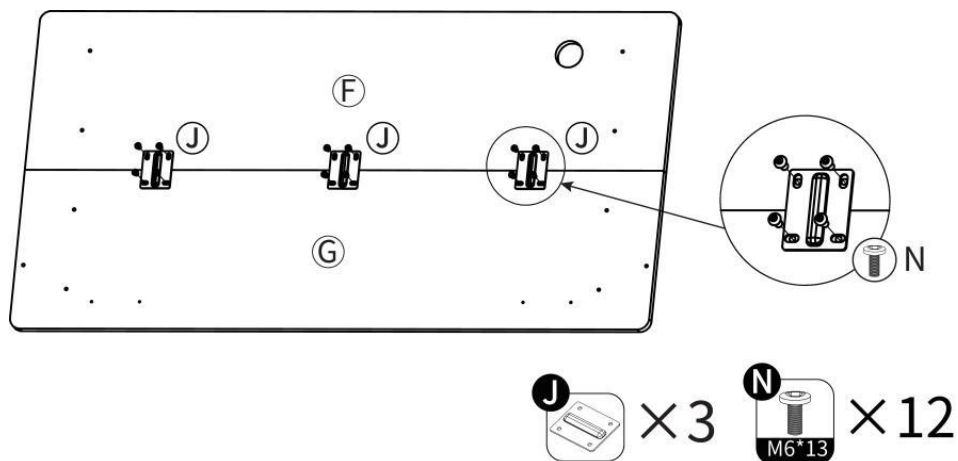

STEP 7 panel installation

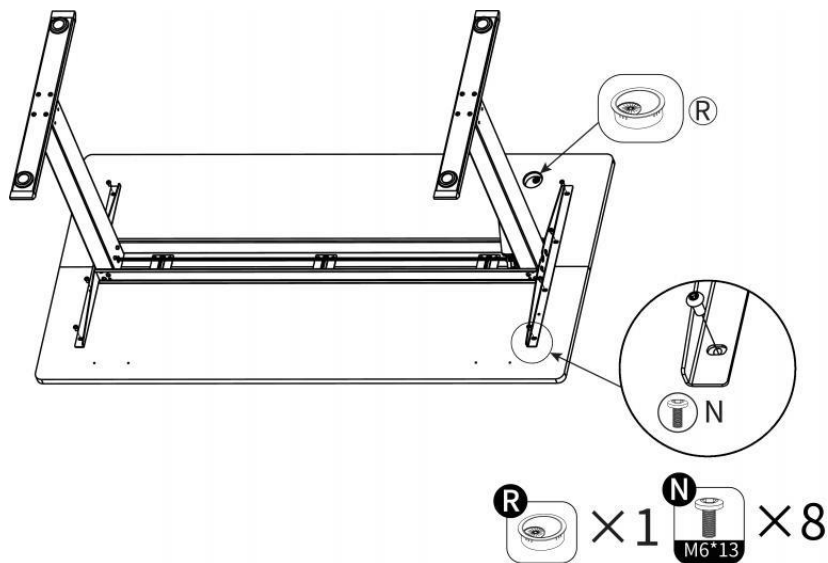

STEP 8 Accessories installation

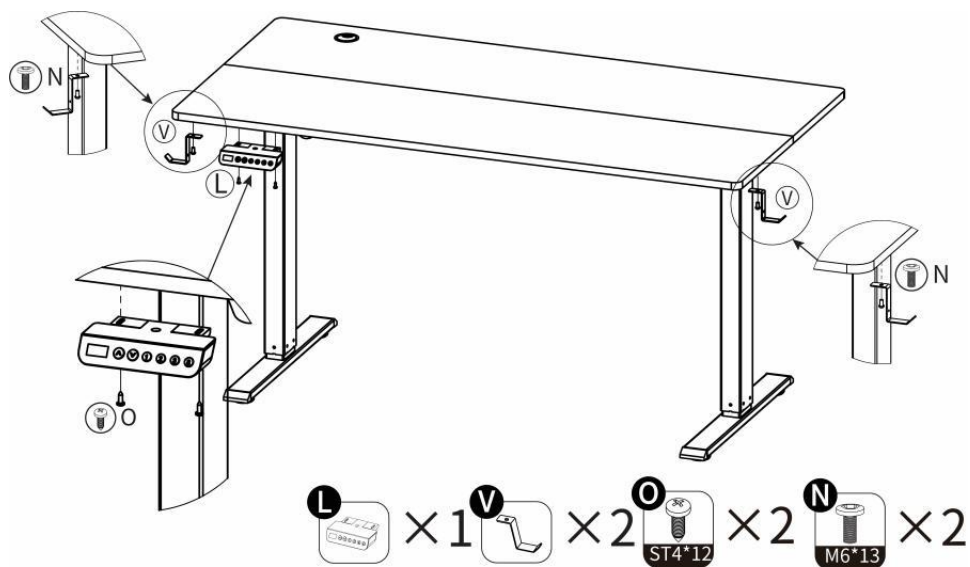



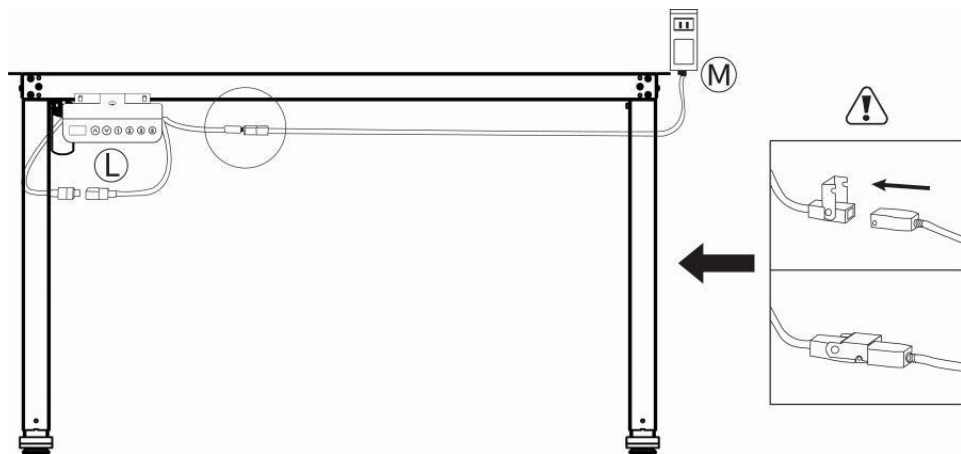

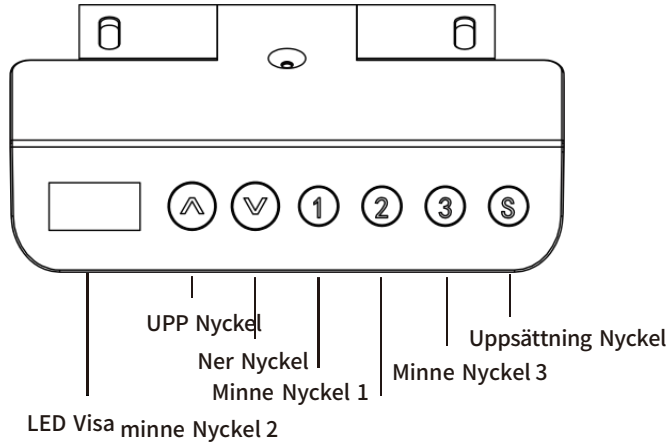

STEG 9 Linjeanslutning



Height Adjustment Controller Operation



- LED Display:
Press any key once to wake up the LED display.
- UP Key: 
Press and hold the UP key to raise the desk.
- Down Key:
Press and hold the DOWN key to lower the desk.
- Memory Key:
   

 Du måste komplett de Initialisering Behandla till r eset din skrivbord före använder det för de först tid.

Detaljerad införande av viktiga funktioner

Återställa

Efter springer till lägst höjd placera, trycka och håll i 7 sekunder. När de LED skärm "först" och "E-1"-blix t växelvis, släpp ↓ nyckel, och trycka och håll nyckel igen. Efter den skrivbordet springer ner till lägst mekanisk noll peka, gå tillbaka 5 mm, de LED skärm visas de lägst höjd värde, och den återställa är klar.

Uppsättning minne höjd + / /

Tryck på S nyckel en gång, och den höjdvärdet kommer start blinkande. På detta tid, trycka de 1, 2, och 3 för att spara strömmen höjd till motsvarande placera.

Utföra minne höjd

I normalt tillstånd, tryck på antal nyckel för att ringa upp dess motsvarande höjd, och de lyft tabell vilja automatiskt kör till motsvarande placera.

Låsa nyckel (S)

Trycka och håll S knapp i 3 sekunder. När de LED skärm visas "UPPSÄTTNING", lära sig till öppna de S nyckel. Tryck på antal knapp 3 för att ange låsskärmen. På detta tid, de LED skärm blinkar och visar "AV".

När på skärmen är låst, trycka och håll S nyckel för 3s, och de LED skärm visas de höjd t värde. Vid den här tiden, släpp S nyckel till slutföra upplåsning.

Återställ fabriksinställningar (S)

Trycka och håll S knapp i 9 sekunder, släpp de S nyckel när den e LED skärm visas "FAC", och kör S nyckel igen till återställa fabrik inställningar.

Fel Koda Instruktioner

| Fel Koda | Resonera | Lösning |
|----------|--|--|
| Fela | Fela är visas när kommunikation linjeföljd mellan manuell kontrollera-ler och den kontrollera låda är fel | / |
| E-1 | När systemet gör inte spara nuvarande position, den LED-skärmen blinkar växelvis till visa "E-1" | Återställa av trycka på lång nyckel tills LED-skärm visar minimum m höjd och den larm är släppa sed |
| E-2 | När motor är låst, den LED visas E-2 | / |
| E-5 | När motor visas: den ansluta linje är koppla ur- ed/lossas, den LED-skärm blinkar växelvis till visa "E-5" | 1. Kontrollera förbindelse rader mellan a ll motorer och den styrenhet till se till att de är fasta, och n återställa av lång trycka på ner nyckel tills LED-skärm visar minimum höjd, och ta bort de larm |
| ovr | När ladda överstiger s et värde, den LED-skärmen blinkar till visa ovr. Vid den här tiden, det är nödvändigt att ta bort w åtta av skrivbordet och driva på de kontroller efter strömförsörjning av. Detta larm burk vara lättad | 1. Normal belastning ska be kontrollerade nedan 120 kg 2. När nuvarande överstiger 4A, den överbelastning skyddsfunktion kommer vara utlöstes |

| | | |
|------|---|---|
| varm | När inre tempera- tur av kontroller överstiger 60 ± 5 grader, den LED visas varm | / |
|------|---|---|

| | | |
|------|---|--|
| voL | När ingångsspänningen för styrenhet överstiger 34V, de LED visar voL | <ol style="list-style-type: none"> 1. När spänningen överstiger 32V, de kontroller är drivs av och den LED skärm är svart; 2. När spänningen sjunker till 32V, de systemet kommer automatiskt svar och LDE vilja visa realtid höjd |
| varm | Efter den motor springer fortsätta i 5 minuter, den LED skärm visas varm, och det kan fungera normalt efter att ha väntat på 10 min | <ol style="list-style-type: none"> 1. Oavbruten drift betyder att drift intervall är inom 3s 2. Detta larm burk också vara borttagen när de kontrollsystem är drivs på igen |
| E-3 | Under operationen, när plötsligt blockerad, den LED skärmen blinkar "E-3", stoppar handling och går 30 mm i motsatt riktning, sedan LED-skärmar de i realtid höjd | Det ska vara såg till att bordet vilja inte vibrera kraftigt, stöta till hinder eller luta under drift |

KOMPLETTERING

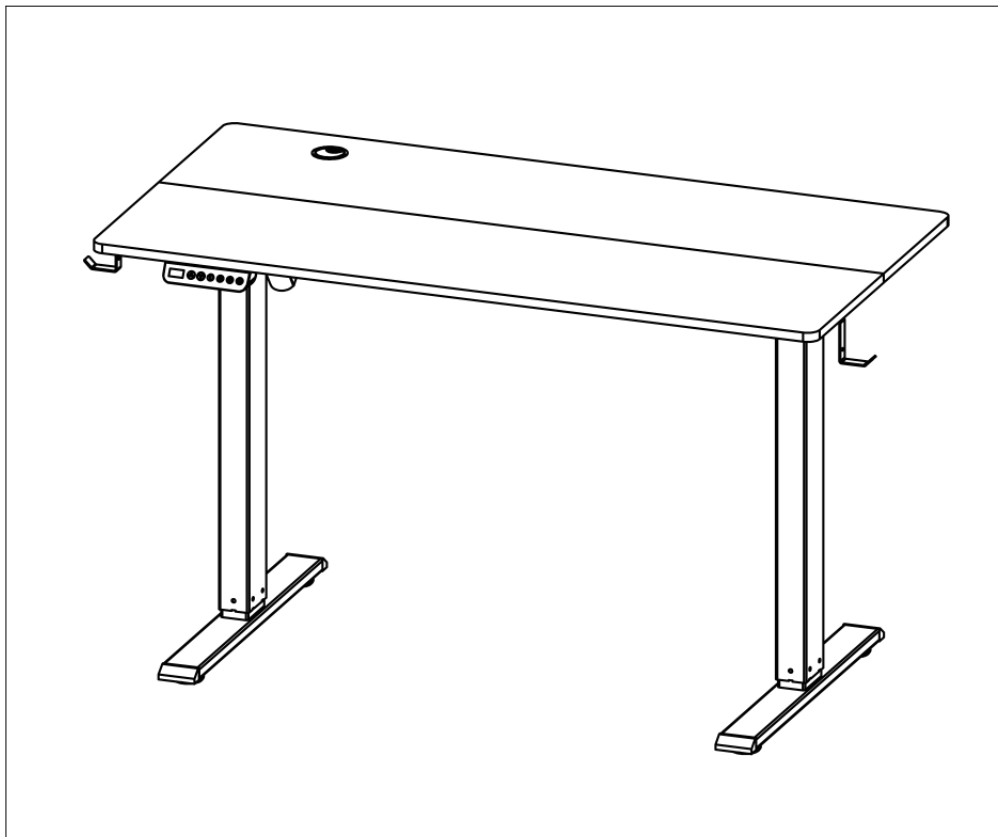

Adress: Shuangchenglu 803nong11hao1602A-1609shi, baoshanqu,
shanghai 200 000 CN.

Importerad till USA : sanven Teknologi Ltd . , svit 250 , 9166 Anaheim plats ,
Rancho cucamonga , CA 91730

| | |
|-----------|------------|
| EC | REP |
|-----------|------------|

E-CrossStu GmbH.
Mainzer Landstr.69, 60329 Frankfurt am Main.

| | |
|-----------|------------|
| UK | REP |
|-----------|------------|

YH KONSULTAT BEGRÄNSAD.
C/OYH Consulting Limited Office 147, Centurion House,
London Road, Staines-upon-Thames, Surrey, TW18 4AX

VEVOR[®]

TOUGH TOOLS, HALF PRICE

Teknisk support och E- garanticertifikat
www.vevor.com/support

VEVOR®

TOUGH TOOLS, HALF PRICE

Técnico Apoyo y Certificado de garantía electrónica

<https://www.vevor.com/support>

ELEVACIÓN PLANA MESA USUARIO MANUAL

Seguimos comprometidos con También le ofrecemos ls competitivos. precio.

"Ahorrar Mitad", "mitad de precio" o cualquier otra expresión similar utilizada por a nosotros solo representa un

Estimación de los ahorros que podría obtener al comprar ciertas herramientas con nosotros en comparación con las principales

Las mejores marcas y no necesariamente significa cubrir todo Categorías de herramientas ofrecidas por Nosotros. Tú

son Le recordamos que debe verificar cuidadosamente cuando esté Realizar un pedido con a nosotros Si tu estas

realmente ahorrando la mitad en comparación con las principales marcas principales.

VEVOR®

TOUGH TOOLS, HALF PRICE

Levantamiento Mesa plana

MODELO NO .: ZWE - DDJ - SS -01, ZWE - DDJ - SS -02, ZWE - DDJ - SS -03,
ZWE - DDJ - SS -04, ZWE - DDJ - SS -05, ZWE - DDJ - SS -06, ZWE -
DDJ - SS -07 ZWE - DDJ - SS -08

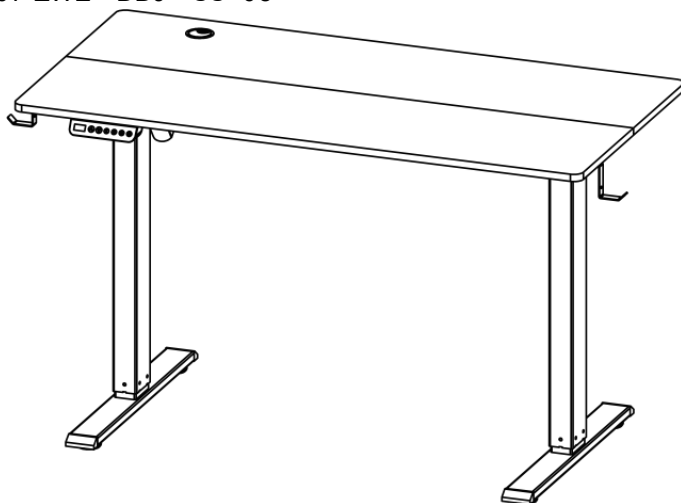

NEED HELP? CONTACT US!

Tener producto ¿preguntas? Necesidad técnico ¿apoyo? Por favor sentir gratis a

contacto nosotros: **Técnico Apoyo y Garantía electrónica Certificado**
www.vevor.com/support

Este es el original instrucción, por favor leer todo manual instrucciones con cuidado antes de operar. VEVO R se reserva una interpretación clara de nuestro manual de usuario. La apariencia del producto debe ser sujeto hacia producto tu recibió. Por favor perdona nosotros que no lo haremos

informarle nuevamente Si hay alguna tecnología o software actualizaciones sobre nuestro producto.



ADVERTENCIA:

Por favor Lee este manual con cuidado antes utilizando el producto. Incumplimiento de hazlo Puede resultar En serio lesión. GUARDE ESTO MANUAL

PRECAUCIONES DE MONTAJE

1. Realizar el montaje únicamente de acuerdo con estas instrucciones. Montaje inadecuado poder crear peligros
2. Tener puesto Gafas de seguridad aprobadas por ANSI y guantes de trabajo resistentes Durante el montaje.
3. Mantener el área de reunión limpio y bien iluminado.
4. Mantener transeúntes fuera del área durante la reunión.
5. Hacer No se reúnen cuando están cansados o cuando bajo la influencia de alcohol, drogas, o medicamento.
6. El Las capacidades del producto se aplican de manera adecuada y completamente ensamblado Sólo productos.
7. Montar sobre una superficie plana y nivelada. superficie dura y lisa capaz de forma segura apoyando el Levantamiento Mesa plana .
8. Para obtener más información información Respecto a las piezas enumeradas En lo siguiente páginas, por favor referirse a la Asamblea Diagrama de este manual. Desarrollar y separar todo partes de un trabajo claro área.

USAR PRECAUCIONES

PARA PREVENIR GRAVES LESIÓN Y MUERTE DE PROPINA:

1. Este producto es No es un juguete. Hacer No permitir Niños a jugar con o acercarse este artículo.
2. Utilícelo únicamente según lo previsto. Hacer no sentarse o pararse en el mesa.

3. Inspeccionar Antes de cada uso. No usar él si regiones son suelto o dañado. Úselo únicamente en superficies planas y niveladas. y duro superficies .









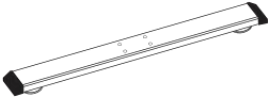
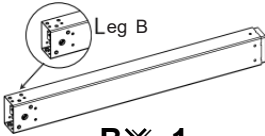
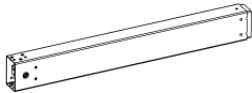

ESPECIFICACIONES TÉCNICAS

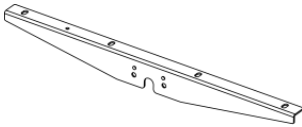



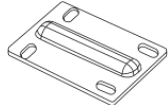

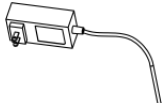

| | | |
|---|--------------------------------|--------------------------------|
| Modelo | ZWE-DDJ-SS-01 ZWE-DDJ-SS-02 | ZWE-DDJ-SS-03 ZWE-DDJ-SS-04 |
| Clasificación(es) del adaptador | 100-240 V~, 50/60 Hz, 1,5 A | |
| Principal Material | Acero + Junta | Acero + Junta |
| Color | Marrón + Negro | Marrón + Negro |
| Producto Dimensiones (Largo x Ancho x Alto) | 1200 x 600 x 1145 mm | 1200 x 800 incógnita 1145 mm |
| Embalaje Tamaño (Largo x Ancho x Alto) | 1295 x 395 incógnita 120 mm | 1295 x 495 x 120 mm |
| Peso neto (kilogramo) | 21.8 | 25.2 |
| Peso bruto (kg) | 24.5 | 27.9 |

| | | |
|---|--------------------------------|--------------------------------|
| Modelo | ZWE-DDJ-SS-05 ZWE-DDJ-SS-06 | ZWE-DDJ-SS-07 ZWE-DDJ-SS-08 |
| Clasificación(es) del adaptador | 100-240 V~, 50/60 Hz, 1,5 A | |
| Principal Material | Acero + Junta | Acero + Junta |
| Color | Marrón + Negro | Marrón + Negro |
| Producto Dimensiones (Largo x Ancho x Alto) | 1400 x 600 x 1145 mm | 1400 x 700 x 1145 mm |
| Embalaje Tamaño (Largo x | 1493 x 405 x 120 mm | 1490 x 455 x 120 mm |

| | | |
|--------------------------|------|------|
| Ancho x Alto) | | |
| Peso neto (kilogramo) | 23.2 | 24.9 |
| Peso bruto (kg) | 26.1 | 27.9 |

CONTENIDO DEL PAQUETE

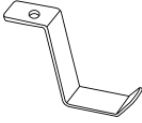
| | | |
|---|---|--|
|  <p>AX × 2</p> |  <p>B × 1</p> |  <p>d0 × 1</p> |
|  <p>D × 2</p> | |  <p>mi × 2</p> |
|  <p>F × 1</p> |  <p>GRAMO × 1</p> | |
|  <p>y0 × 1</p> | |  <p>I × 1</p> |
|  <p>Y0 × 3</p> |  <p>K × 4</p> |  <p>y0 × 1</p> |
|  <p>METRO × 1</p> |  <p>M6*13 n0 × 38</p> |  <p>ESTANCI A 4*12 O × 2</p> |

| | | |
|--|---|---|
|  <p>M4*40</p> <p>PAG × 2</p> |  <p>M6*35</p> <p>Q × 8</p> |  <p>R × 1</p> |
|  <p>S × 1</p> |  <p>yo × 4</p> |  <p>tú × 1</p> |
|  <p>V × 2</p> |  <p>Y × 4</p> | |

PASOS DE MONTAJE

PASO 1 Pie instalación

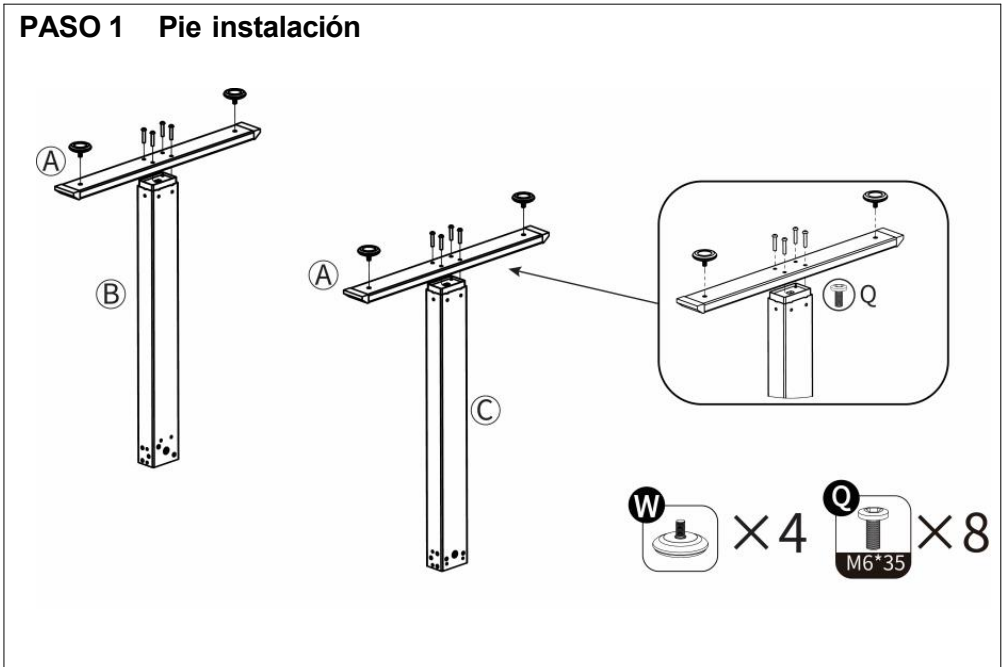

PASO 2 Instalación del motor

①

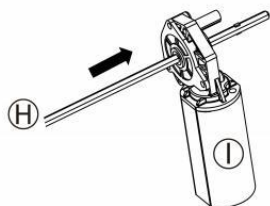

First, insert the motor from the end of the hexagonal rod without a bump to the other end with a bump.

②

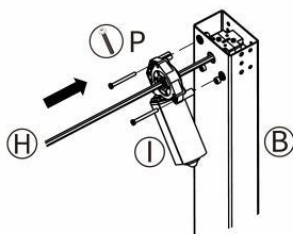

Then, insert the convex end of the motor into leg B together with the motor. Tighten the motor on leg B with the screws shown in the picture.



PASO 3 Conducir vara instalación

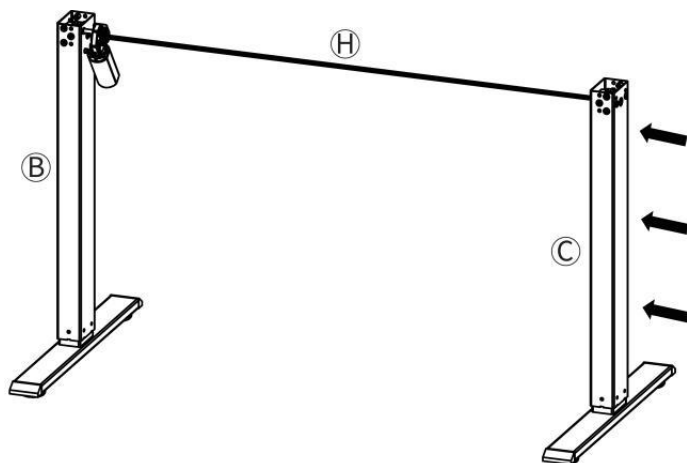

After completing the previous step, insert leg C into the hex stick.



If the holes are misaligned, hold the motor by hand and adjust the hex rod to rotate slightly so that the hex rod can be inserted into leg C.

PASO 4 Haz instalación

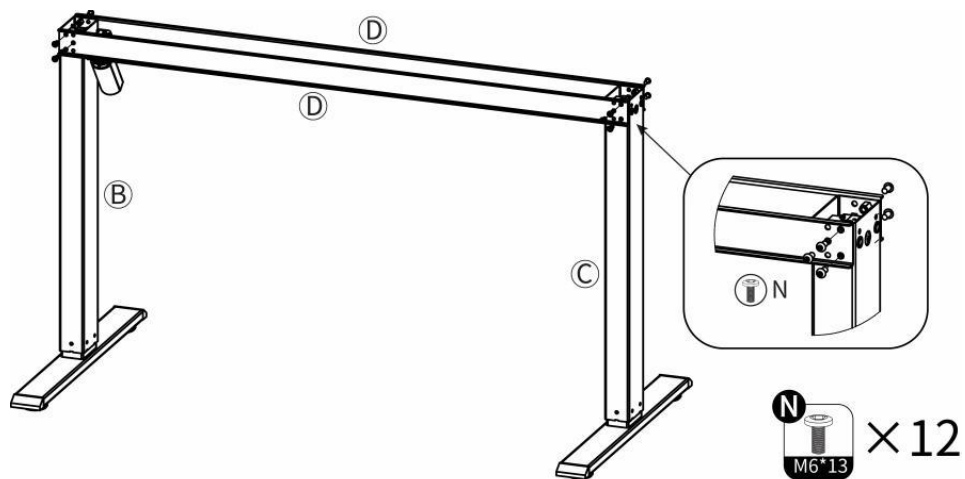

PASO 5 Instalación de ala lateral

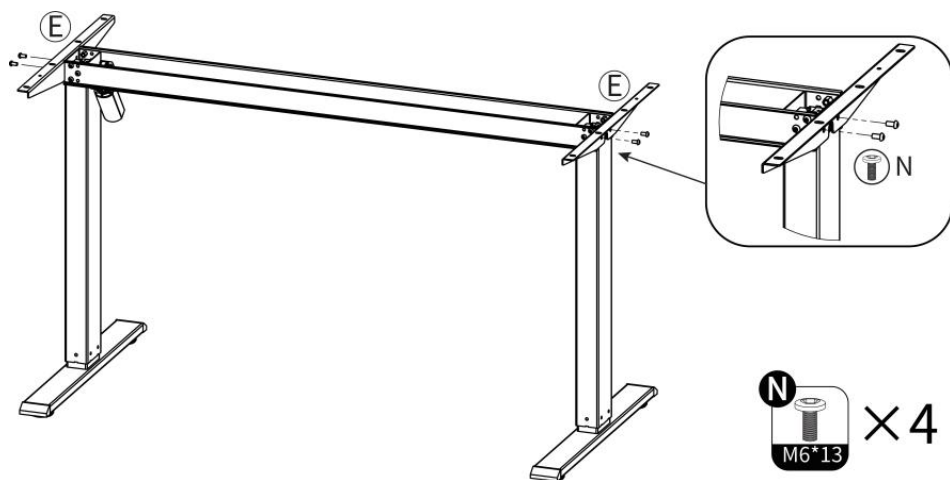

PASO 6 Empalme de paneles (1)

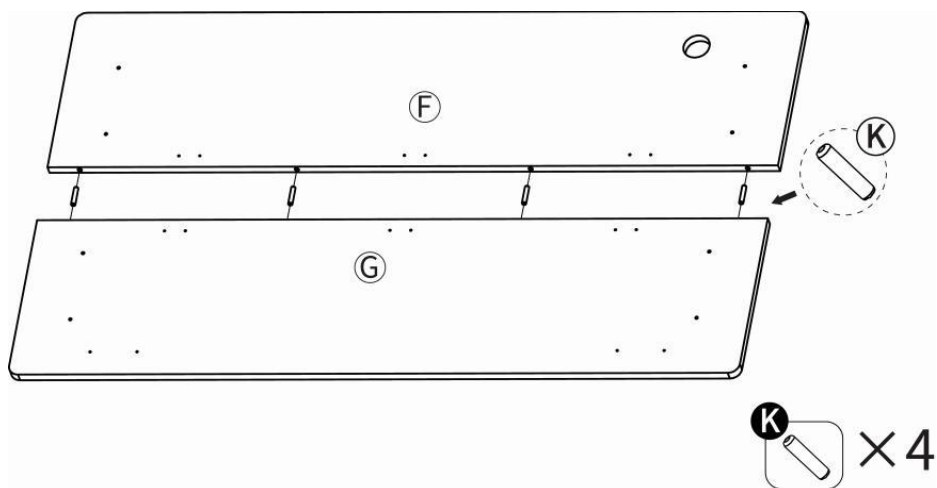

PASO 6 Unión de paneles (2)

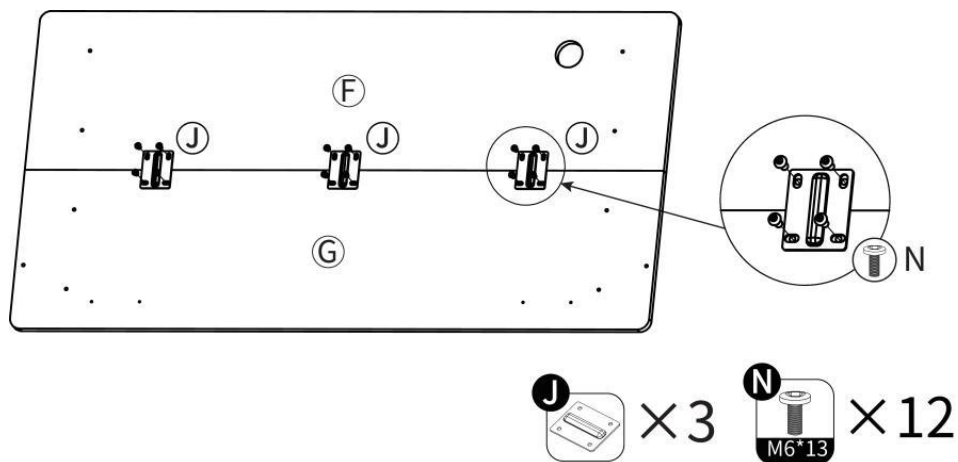

PASO 7 panel instalación

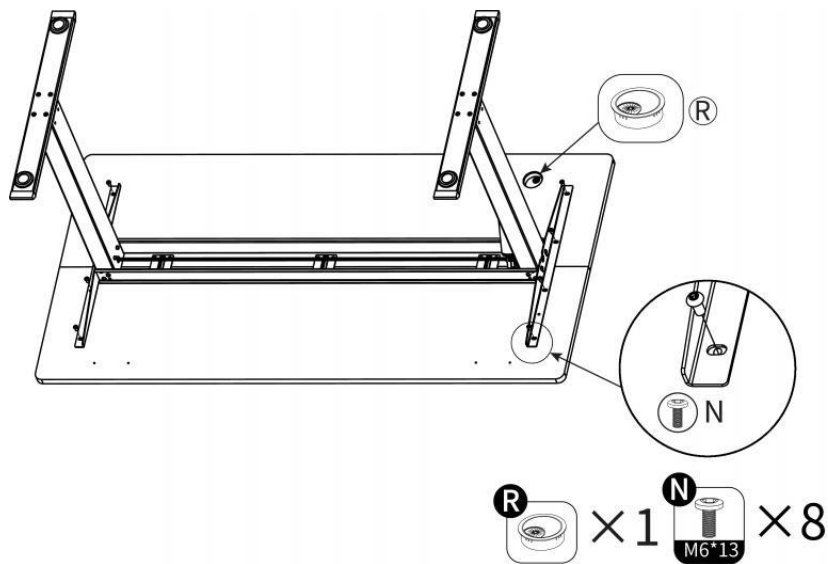

PASO 8 Accessories installation

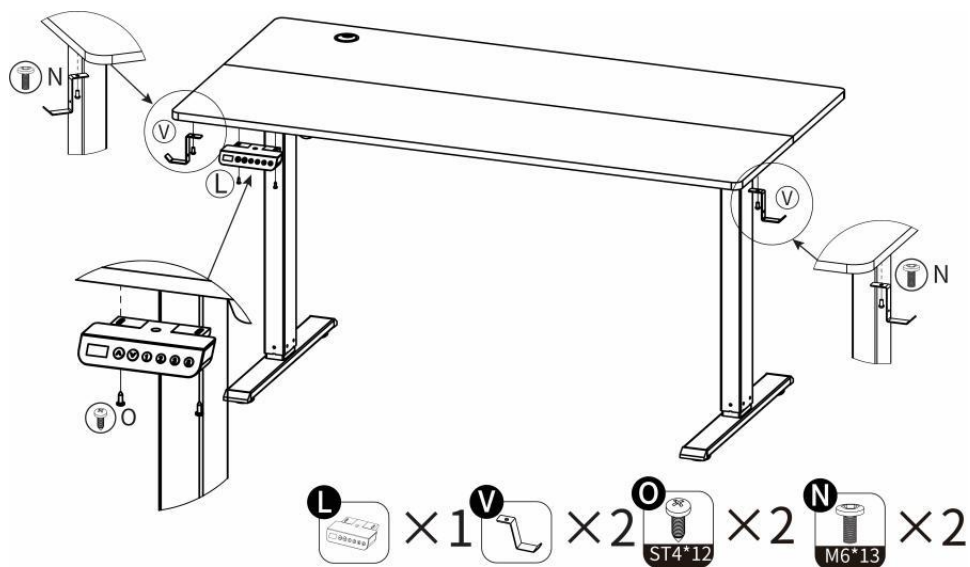



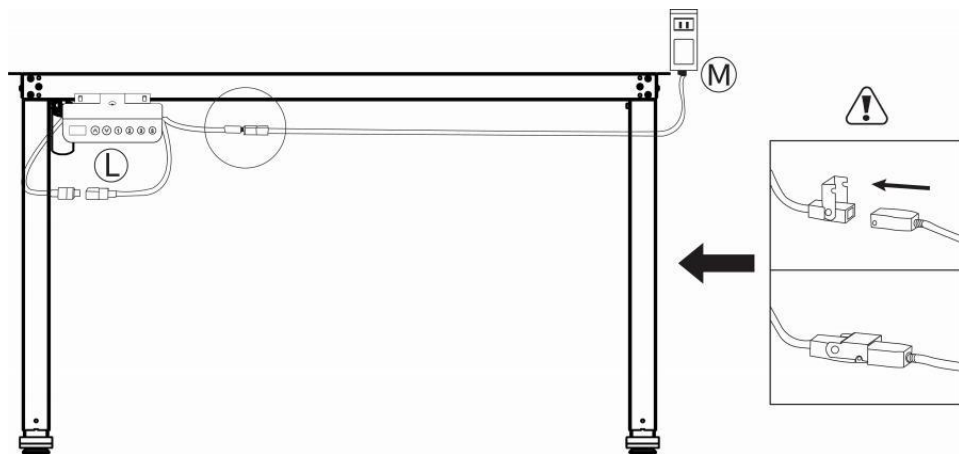

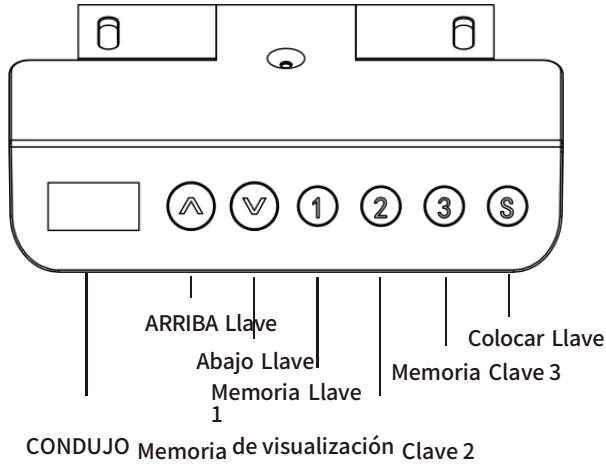

PASO 9 Conexión de línea



Height Adjustment Controller Operation



- LED Display:
Press any key once to wake up the LED display.
- UP Key: 
Press and hold the UP key to raise the desk.
- Down Key: 
Press and hold the DOWN key to lower the desk.
- Memory Key:
   



Tú debe completo el Inicialización Proceso a reiniciar su escritorio antes usando él para el primero tiempo.

Detallado Introducción de funciones clave

Reiniciar

Después corriendo hacia el más bajo altura posición, prensa y Mantenga pulsado durante 7 segundos. Cuando el CONDUJO pantalla "primero" y Flash "E-1" alternativamente, liberar el ↓ llave, y prensa y Sostener el llave De nuevo. Después de la de oficina corre hacia el más bajo cero mecánico apuntar, ir atrás 5 mm, el CONDUJO pantalla muestra el más bajo valor de altura , y el reiniciar esta completado

Colocar memoria altura + / /

Presiona la S tecla una vez, y el El valor de la altura será comenzar parpadeando. este tiempo, prensa el 1, 2, y 3 Teclas para guardar la corriente altura a la correspondiente posición.

Ejecutar memoria altura

En estado normal, presione el número tecla para llamar arriba su correspondiente altura, y el levantamiento mesa voluntad automáticamente corre al correspondiente posición.

Cerrar llave (S)

Prensa y Mantenga la S tecla durante 3 segundos. Cuando el CONDUJO pantalla muestra "COLOCAR", aprender a abierto el S llave. Presione el número tecla 3 para entrar en el pantalla de bloqueo Estado. En este tiempo, el CONDUJO pantalla Destellos y muestra "APAGADO". Cuando en la pantalla es bloqueado, prensa y Mantenga la S tecla para 3s, y el CONDUJO pantalla muestra el altura valor. En este momento, Suelte la S clave para Completar el desbloqueo.

Restaurar configuración de fábrica (S)

Prensa y Mantenga la S tecla durante 9 segundos, liberar el S llave cuando el CONDUJO pantalla muestra "FAC", y operar el S llave De nuevo a restaurar el fábrica ajustes.

Error Código Instrucciones

| Error Código | Razón | Solución |
|--------------|---|---|
| Error | Errar es se muestra cuando el comunicación secuencia de línea Entre el manual control- más y el control caja es equivocado | / |
| E-1 | Cuando el sistema hace no Guardar el actual posición , la La pantalla LED parpadea alternativamente a mostrar "E-1" | Reiniciar por presionando el largo llave hasta el Pantalla LED muestra el mínimo m altura y el alarma es liberado |
| E-2 | Cuando el motor es bloqueado, el CONDUJO muestra E-2 | / |
| E-5 | Cuando el motor aparece: el Conectando línea es desconectar- ed/aflojado, el Pantalla LED Destellos alternativamente a mostrar "E-5" | 1. Comprueba el conexión pauta entre todo motores y el controlador a Asegúrese de que ellos son firmes, y luego reiniciar por largo presionando el abajo llave hasta el Pantalla LED muestra el mínimo altura, y eliminar el alarma |
| sobre | Cuando el carga excede el s et valor, el La pantalla LED parpadea a mostrar ovr. En este momento, él es necesario para Quitar el peso del de oficina y fuerza en el controlador después Alimentando Apagado. Esto alarma poder ser aliviado | 1. Normal La carga deberá ser revisado abajo 120 kg 2. Cuando el actual excede los 4A, el sobrecarga La función de protección será ser motivado |

| | | |
|----------|---|---|
| caliente | Cuando el temperatura interna tura del controlador excede 60 ± 5 grados, los CONDUJO muestra caliente | / |
|----------|---|---|

| | | |
|----------|--|--|
| vol. | <p>Cuando el voltaje de entrada del controlador supera los 34 V, el CONDUJO muestra vol</p> | <ol style="list-style-type: none"> 1. Cuando el voltaje supera los 32 V, el controlador es motorizado Apagado y el CONDUJO pantalla es negro; 2. Cuando el voltaje baja a 32 V, el El sistema lo hará automáticamente responder y LDE voluntad mostrar el tiempo real altura |
| caliente | <p>Después de la motor corre Continuo- durante 5 minutos, el CONDUJO pantalla muestra caliente, y él puede trabajar normalmente Después de esperar 10 minutos</p> | <ol style="list-style-type: none"> 1. Ininterrumpido operación significa que el operación intervalo está dentro de 3s 2. Esto alarma poder también ser eliminado cuando el sistema de control es motorizado en de nuevo |
| E-3 | <p>Durante la operación, cuando de repente bloqueado, el CONDUJO La pantalla parpadea "E-3", detiene el acción y corre 30mm en el opuesto dirección, entonces el Pantallas LED el tiempo real altura</p> | <p>Deberá ser aseguró que la mesa voluntad no vibrar significativamente, bulto en obstáculos o inclinarse durante operación</p> |

TERMINACIÓN

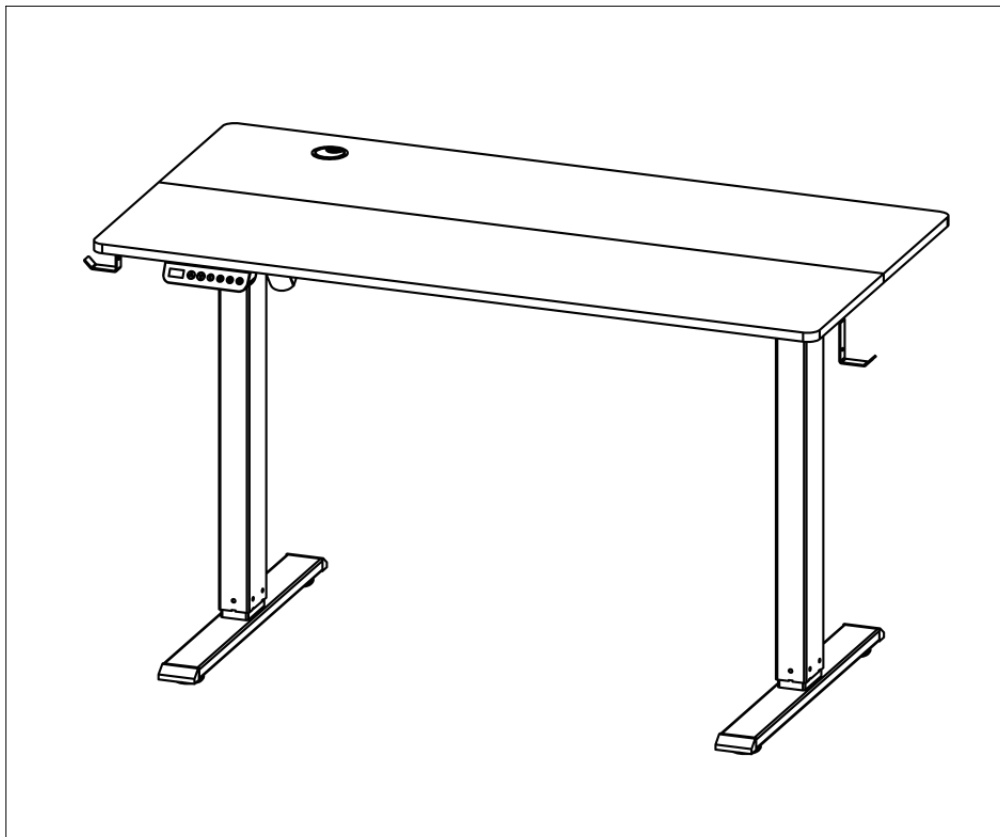

Dirección: Shuangchenglu 803nong11hao1602A-1609shi, baoshanqu,
Shangai 200000 CN.

Importado a EE.UU : sanar Tecnología Limitada . , suite 250 , 9166 Anaheim
lugar , rancho cucamonga , CA 91730

| | |
|-----------|------------|
| EC | REP |
|-----------|------------|

Empresa E-CrossStu GmbH.

Calle Mainz Landstr.69, 60329 Frankfurt am Main
Principal.

| | |
|-----------|------------|
| UK | REP |
|-----------|------------|

CONSULTORÍA YH LIMITADO.

Consultoría C/OYH Oficina limitada 147, Centurión
Casa, Londres Carretera, Staines-upon-Thames, Surrey,
TW184AX

VEVOR[®]

TOUGH TOOLS, HALF PRICE

Soporte técnico y Certificado de garantía
electrónica www.vevor.com/support

VEVOR[®]

TOUGH TOOLS, HALF PRICE

Tecnico Supporto e Certificato di garanzia elettronica

<https://www.vevor.com/support>

SOLLEVAMENTO PIATTO TAVOLO UTENTE MANUALE

Continuiamo ad impegnarci per fornirti anche Is con competitivo prezzo.

"Salva Metà", "Metà prezzo" o altre espressioni simili utilizzate di noi soltanto rappresenta un stima del risparmio che potresti ottenere acquistando determinati utensili con noi rispetto ai principali i migliori marchi e non significa necessariamente copertina Tutto categorie di strumenti offerti di noi. Tu

Sono si ricorda gentilmente di verificare attentamente quando si è effettuare un ordine con noi se tu sei effettivamente risparmiando la metà rispetto ai marchi più importanti.

VEVOR®

TOUGH TOOLS, HALF PRICE

Sollevamento Tavolo piatto

MODELLO N. : ZWE - DDJ - SS -01, ZWE - DDJ - SS -02, ZWE - DDJ - SS -03,
ZWE - DDJ - SS -04, ZWE - DDJ - SS -05, ZWE - DDJ - SS -06, ZWE -
DDJ - SS -07 ZWE - DDJ - SS -08

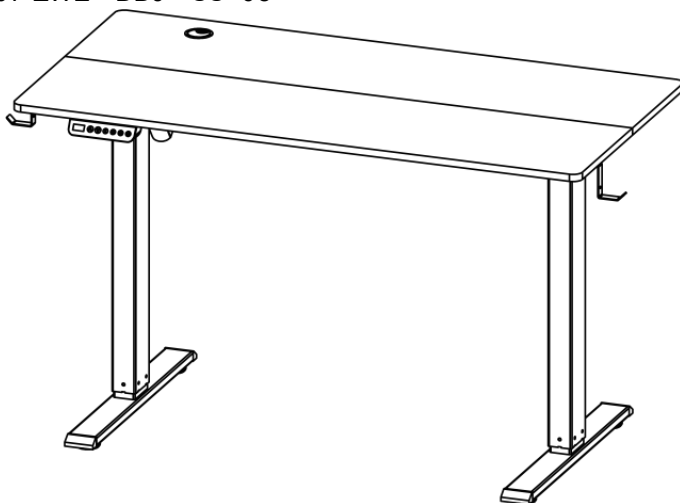

NEED HELP? CONTACT US!

Avete prodotto domande? Bisogno tecnico supporto? Per favore Tasto gratuito A

contatto noi: **Tecnico Supporto E Garanzia elettronica Certificato**
www.vevor.com/support

Questo è l'originale istruzione, Per favore rileggere tutto manuale istruzioni

accuratamente prima di operare. VEVO R si riserva una chiara interpretazione del nostro manuale utente. L'aspetto del prodotto deve Essere soggetto al prodotto tu ricevuto. Per favore perdonami noi che non lo faremo

informarti di nuovo se ci sono tecnologie o software aggiornamenti sul nostro prodotto.



AVVERTIMENTO:

Per favore leggi questo manuale con attenzione Prima utilizzando il prodotto. Mancato rispetto farlo può risultare in modo serio infortunio. SALVA QUESTO MANUALE

PRECAUZIONI DI MONTAGGIO

1. Montare solo seguendo queste istruzioni. Montaggio non corretto Potere creare pericoli.
2. Indossare Occhiali di sicurezza approvati ANSI e guanti da lavoro resistenti durante l'assemblaggio.
3. Mantenere l'area di assemblaggio pulito e ben illuminato.
4. Mantenere gli astanti fuori dall'area durante l'assemblea.
5. Fare non riunirsi quando si è stanchi o quando sotto l'influenza di alcol, droga, o farmaco.
6. IL le capacità del prodotto si applicano correttamente e completamente assemblato solo prodotti.
7. Montare su una superficie piana e livellata, superficie dura e liscia capace di sicuro sostenere il Sollevamento Tavolo piatto .
8. Per ulteriori informazioni informazioni per quanto riguarda le parti elencate nell'ala seguente pagine, per favore fare riferimento al Assemblea Schema di questo manuale. Scartare e separare tutti parti su un lavoro chiaro zona.

UTILIZZO PRECAUZIONI

PER PREVENIRE GRAVI INFORTUNIO E MORTE DALLA MANCIA:

1. Questo prodotto È non è un giocattolo. Fare non permettere bambini a giocare con O approccio Questo articolo.
2. Utilizzare solo come previsto. Fare non sedersi O in piedi SU IL tavolo.

3. Ispezionare prima di ogni utilizzo. Non fare utilizzo Esso Se parti Sono sciolto o danneggiato. Utilizzare solo su superfici piane e livellate, E difficile superfici .









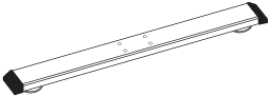
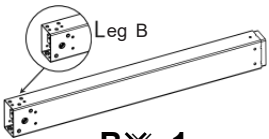
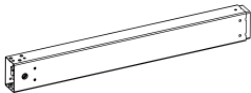

SPECIFICHE TECNICHE

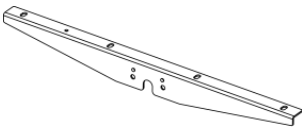



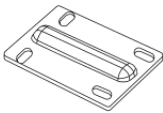

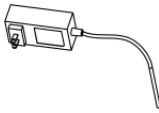

| | | |
|--|--|--|
| Modello | Modello ZWE- DDJ-SS-01 Modello ZWE- DDJ-SS-02 | Modello ZWE- DDJ-SS-03 Modello ZWE- DDJ-SS-04 |
| Valutazione dell'adattatore | 100-240 V~, 50/60 Hz, 1,5A | |
| Principale Materiale | Acciaio + Asse | Acciaio + Asse |
| Colore | Marrone + Nero | Marrone + Nero |
| Prodotto Dimensioni (Lunghezza x Larghezza x Altezza) | Dimensioni: 1200x600x 1145 mm | 1200x800 X 1145 mm |
| Imballaggio Misurare (Lunghezz a x Larghezza x Altezza) | Dimensioni: 1295 x 395 X 120 mm | Dimensioni: 1295 x 495 x 120 mm |
| Peso netto (kg) | 21.8 | 25.2 |
| Peso lordo (kg) | 24.5 | 27.9 |

| | | |
|-----------------------------|--|--|
| Modello | Modello ZWE- DDJ-SS-05 Modello ZWE- DDJ-SS-06 | Modello ZWE- DDJ-SS-07 Modello ZWE- DDJ-SS-08 |
| Valutazione dell'adattatore | 100-240 V~, 50/60 Hz, 1,5A | |
| Principale Materiale | Acciaio + Asse | Acciaio + Asse |
| Colore | Marrone + Nero | Marrone + Nero |

| | | |
|---|------------------------------------|------------------------------------|
| Prodotto Dimensioni (Lunghezza x Larghezza x Altezza) | Dimensioni: 1400x600x 1145 mm | Dimensioni: 1400x700x 1145 mm |
| Imballaggio Misurare (Lunghezza x Larghezza x Altezza) | Dimensioni: 1493 x 405 x 120 mm | Dimensioni: 1490 x 455 x 120 mm |
| Peso netto (kg) | 23.2 | 24.9 |
| Peso lordo (kg) | 26.1 | 27.9 |

CONTENUTO DELLA CONFEZIONE

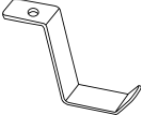
| | | |
|---|--|---|
|  <p>U × 2</p> |  <p>B × 1</p> |  <p>C × 1</p> |
|  <p>D × 2</p> | |  <p>E × 2</p> |
|  <p>F × 1</p> |  <p>G × 1</p> | |
|  <p>H × 1</p> |  <p>I × 1</p> | |
|  <p>J × 3</p> |  <p>E × 4</p> |  <p>L × 1</p> |
|  <p>M × 1</p> |  <p>N × 38 M6*13</p> |  <p>L × 2 4*12 di serie</p> |

| | | |
|--|---|---|
|  <p>M4*40</p> <p>P × 2</p> |  <p>M6*35</p> <p>Q × 8</p> |  <p>R × 1</p> |
|  <p>S × 1</p> |  <p>T × 4</p> |  <p>Io × 1</p> |
|  <p>E × 2</p> |  <p>L × 4</p> | |

FASI DI MONTAGGIO

PASSO 1 Piede installazione

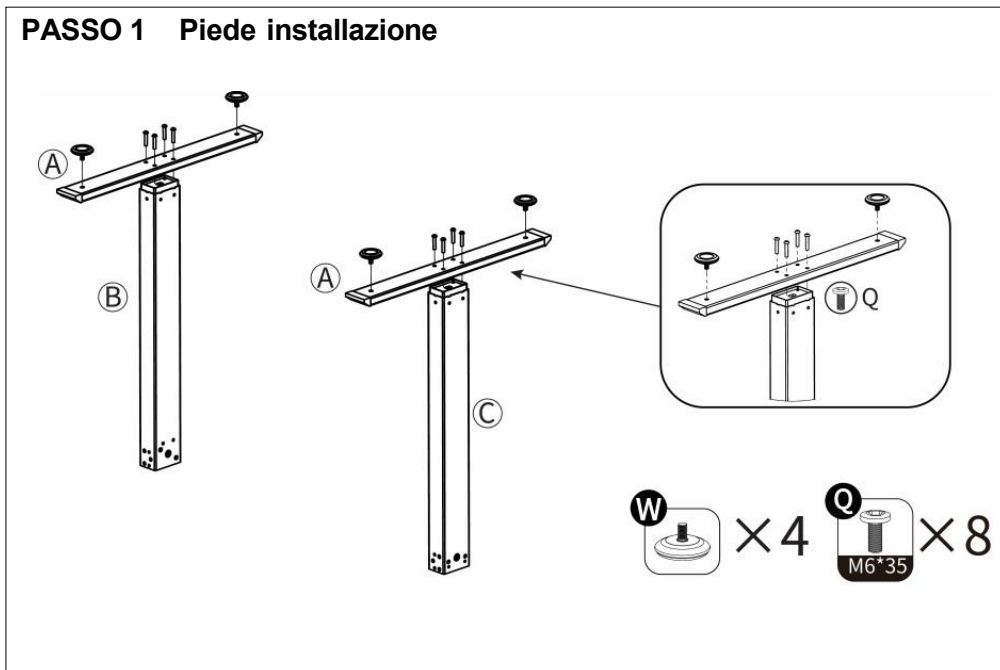

PASSO 2 Installazione del motore

①

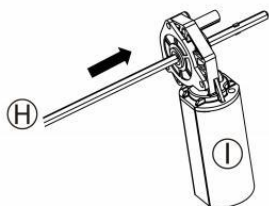

First, insert the motor from the end of the hexagonal rod without a bump to the other end with a bump.

②

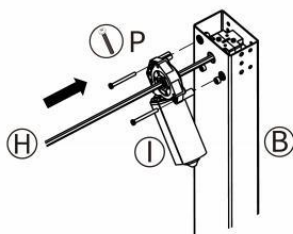

Then, insert the convex end of the motor into leg B together with the motor. Tighten the motor on leg B with the screws shown in the picture.



PASSO 3 Guidare asta installazione

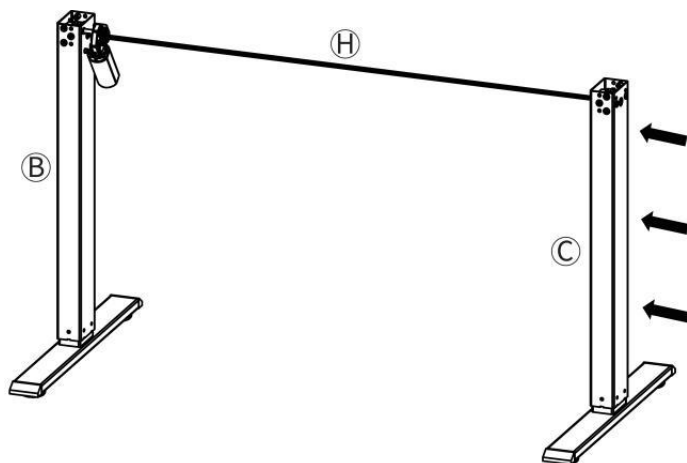

After completing the previous step, insert leg C into the hex stick.



If the holes are misaligned, hold the motor by hand and adjust the hex rod to rotate slightly so that the hex rod can be inserted into leg C.

PASSO4 Trave installazione

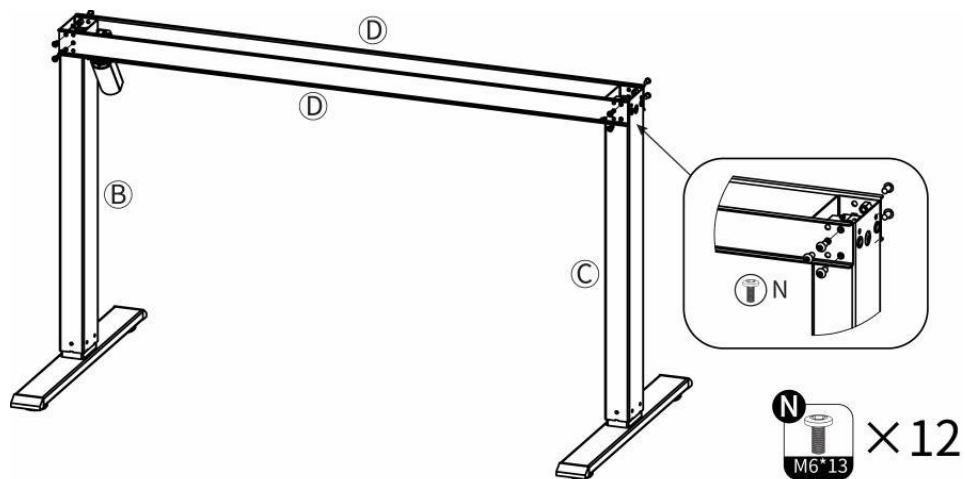

PASSO 5 Installazione ala laterale

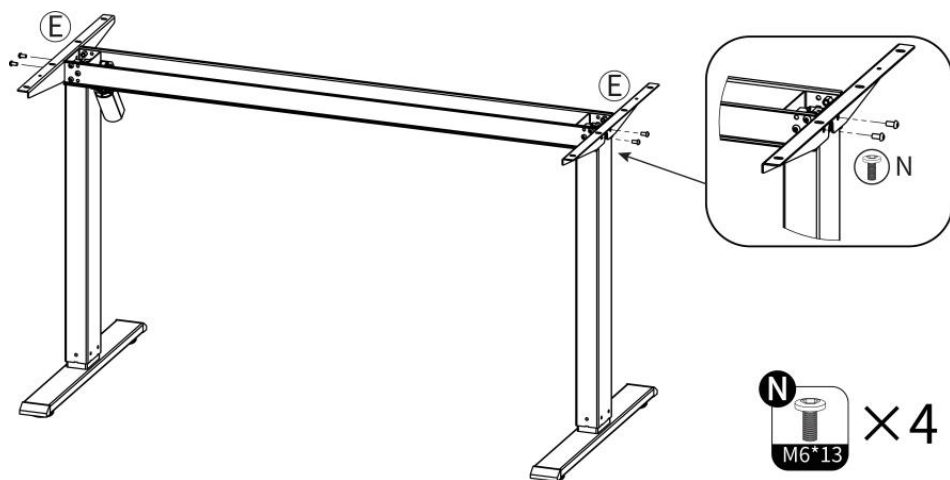

STEP6 Giunzione del pannello (1)

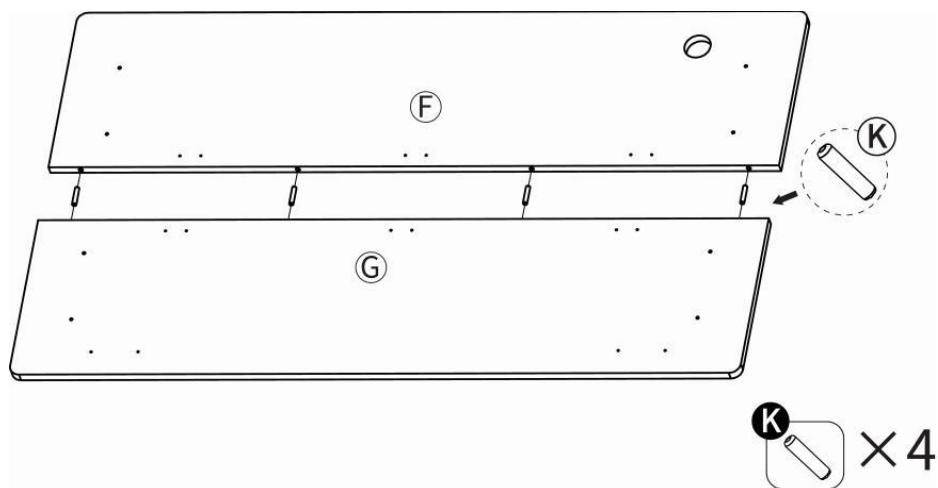

PASSO6 Giunzione del pannello (2)

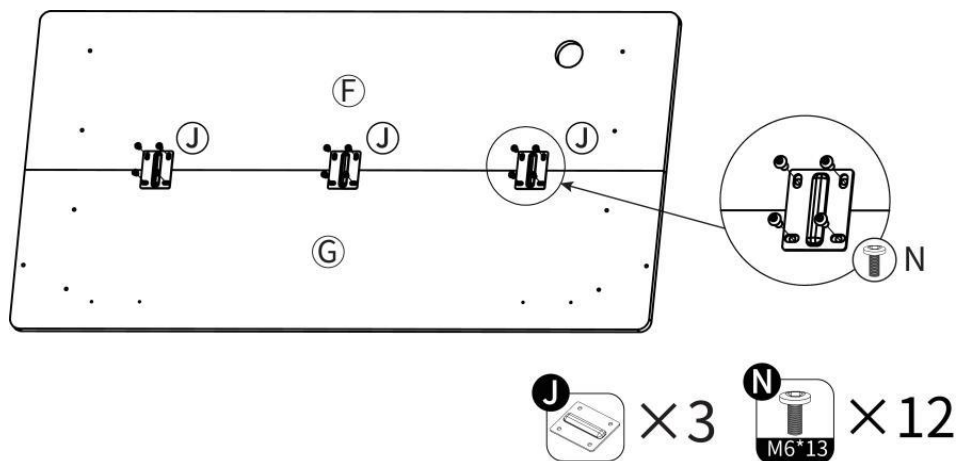

PASSO 7 pannello installazione

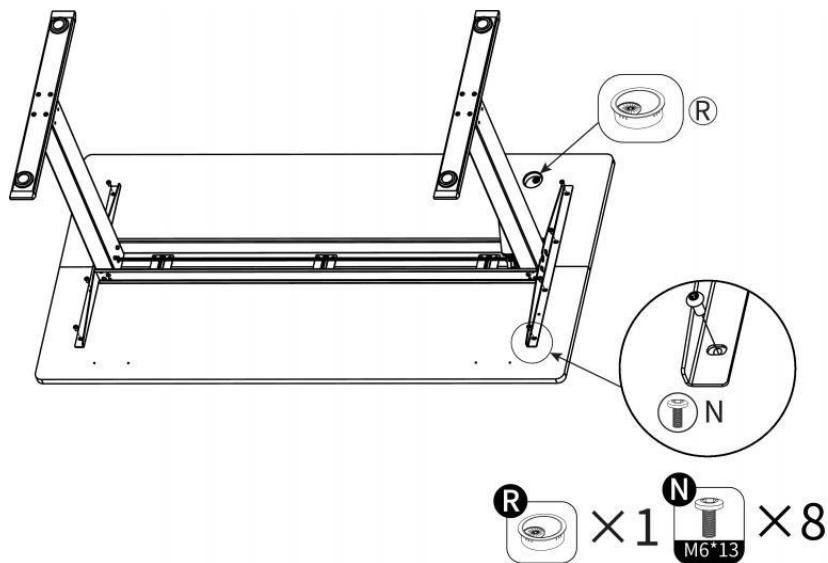

PASSO 8 Accessories installation

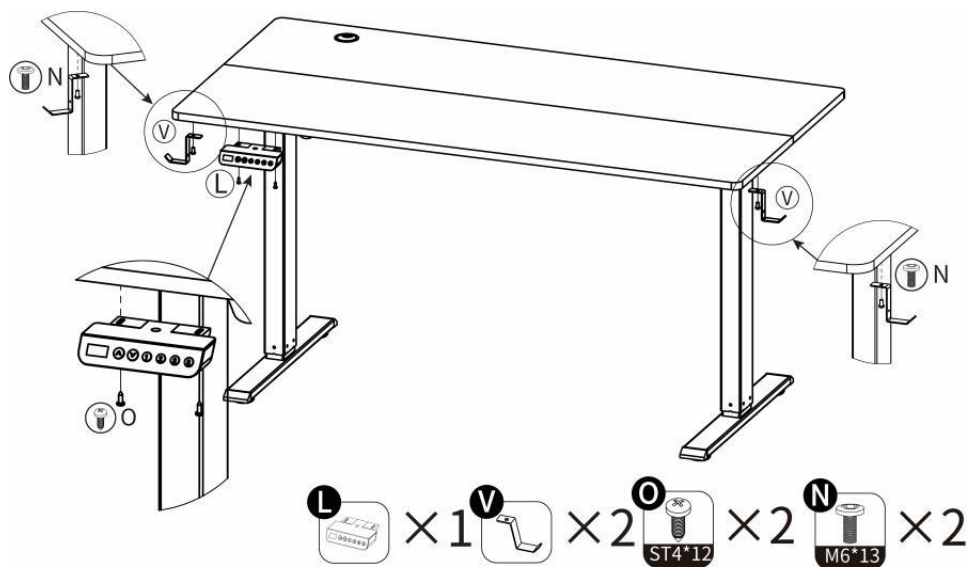



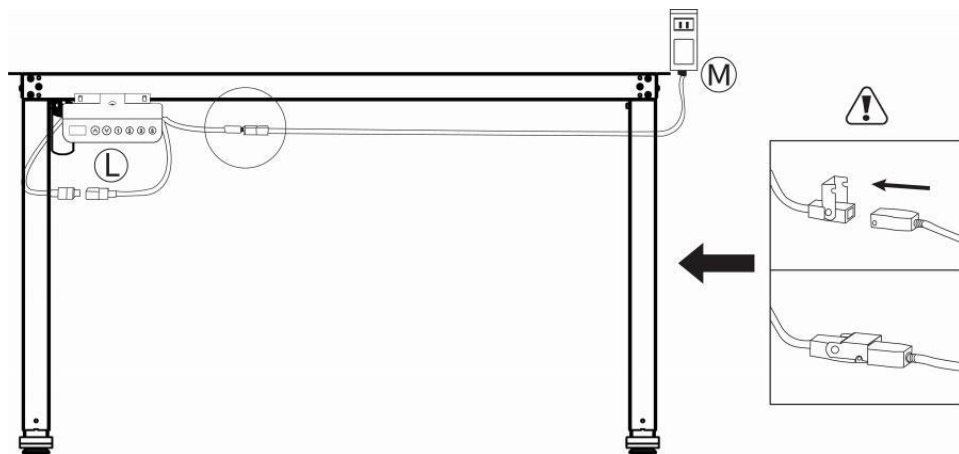

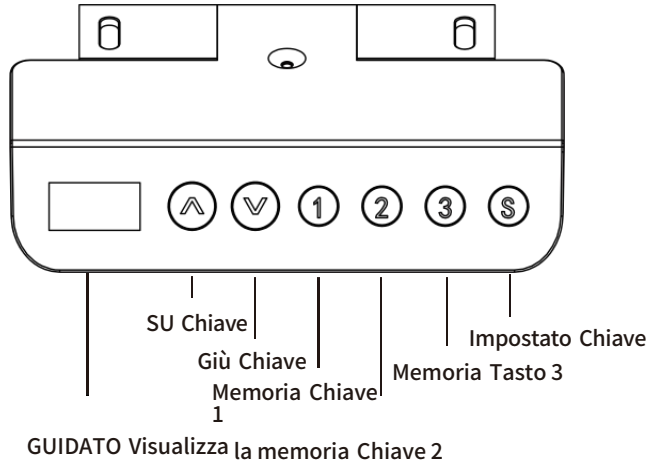

PASSO 9 Collegamento di linea



Height Adjustment Controller Operation



- LED Display:
Press any key once to wake up the LED display.
- UP Key: 
Press and hold the UP key to raise the desk.
- Down Key: 
Press and hold the DOWN key to lower the desk.
- Memory Key:
   



Voi dovere completare IL Inizializzazione Processo A ripristinare tuo scrivania Prima usando Esso per IL primo tempo.

Dettagliato introduzione di funzioni chiave

Reset

Dopo correre verso il più basso altezza posizione, premere E tenere premuto per 7 secondi. Quando IL GUIDATO schermo "primo" E "E-1" flash in alternativa, rilasciare il ↓ chiave, E premere E tenere il chiave di nuovo. Dopo il tavolozza corre fino al il più basso zero meccanico punto, andare Indietro 5mm, IL GUIDATO schermo mostra IL il più basso valore altezza , e il reset è completato.

Impostato memoria altezza + / /

Premere il tasto S chiave una volta, e il il valore dell'altezza sarà inizio lampeggiante. A Questo tempo, premere IL 1, 2, E 3 tasti per salvare la corrente altezza al corrispondente posizione.

Eeguire memoria altezza

In stato normale, premere il numero chiave per chiamare su il suo corrispondente altezza, E IL sollevamento tavolo Volere automaticamente correre al corrispondente posizione.

Serratura chiave (S)

Premere E tieni premuto il tasto S tasto per 3 secondi. Quando IL GUIDATO schermo mostra "IMPOSTATO", Imparare A aprire IL S chiave. Premere il numero tasto 3 per entrare nel schermata di blocco stato. A Questo tempo, IL GUIDATO schermo lampi e visualizza "SPENTO".

Quando lo schermo È bloccato, premere E tieni premuto il tasto S tasto per 3s, E IL GUIDATO schermo mostra IL altezza valore. In questo momento, rilasciare la S chiave per completare il sbloccaggio.

Ripristinare le impostazioni di fabbrica (S)

Premere E tieni premuto il tasto S tasto per 9 secondi, pubblicazione IL S chiave Quando IL GUIDATO schermo mostra "FACCIA", e azionare la S chiave di nuovo a ripristinare il fabbrica impostazioni.

Errore Codice Istruzioni

| Errore Codice | Motivo | Soluzione |
|---------------|---|---|
| Sbagliare | Sbagliare È visualizzato quando il comunicazione sequenza di linee tra il manuale controllare- più e il controllare scatola È sbagliato | / |
| E-1 | Quando il sistema fa non salvare il attuale posizione , il Lo schermo LED lampeggia alternativamente A display "E-1" | Reset di premendo il lungo chiave fino a quando il Schermo LED visualizza il minimo m altezza e il allarme È rilasciato |
| E-2 | Quando il motore È bloccato, il GUIDATO mostra E-2 | / |
| E-5 | Quando il motore appare: il collegamento linea È disconnettere- ed/allentato, il Schermo LED lampi alternativamente a display "E-5" | 1. Controllare il connessione linee fra Tutto motori e il controllore a e assicurati che Essi sono fermi, poi reset di lungo premendo il giù chiave fino a quando il Schermo LED visualizza il minimo altezza, E rimuovere IL allarme |
| sopra | Quando il carico supera il set valore, il Lo schermo LED lampeggia A display ovr. In questo momento, Esso È necessario per rimuovere il peso del tavolozza E energia SU IL controllore Dopo | 1. Normale il carico deve Essere controllato sotto 120KG 2. Quando il attuale supera 4A, il sovraccarico funzione di protezione Essere innescato |

| | | |
|-------|---|---|
| | <p>alimentazione spento. Questo allarme Potere Essere sollevato</p> | |
| caldo | <p>Quando il temperatura interna tura del controllore supera 60 ± 5 gradi, il GUIDATO mostra caldo</p> | / |

| | | |
|--------|--|---|
| volume | Quando il tensione di ingresso del il controller supera i 34 V, IL GUIDATO visualizza vol | <ol style="list-style-type: none"> 1. Quando la tensione supera i 32V, IL controllore È alimentato spento e il GUIDATO schermo È nero; 2. Quando la tensione scende a 32V, IL il sistema sarà automaticamente rispondere E LDE Volere mostrare il tempo reale altezza |
| caldo | Dopo il motore corre continuare- costantemente per 5 minuti, il GUIDATO schermo mostra caldo, E Esso può funzionare normalmente dopo aver aspettato 10 minuti | <ol style="list-style-type: none"> 1. Ininterrotto operazione significa che il operazione intervallo è entro 3s 2. Questo allarme Potere Anche Essere rimosso quando IL sistema di controllo È alimentato SU Ancora |
| E-3 | Durante l'operazione, Quando All'improvviso bloccato, il GUIDATO lo schermo lampeggia "E-3", ferma il azione È corre 30mm nel opposto direzione, quindi il Display a LED IL in tempo reale altezza | Esso dovrà Essere assicurato che il tavolo Volere non vibrare in modo significativo, colpo in ostacoli o inclinarsi durante operazione |

COMPLETAMENTO

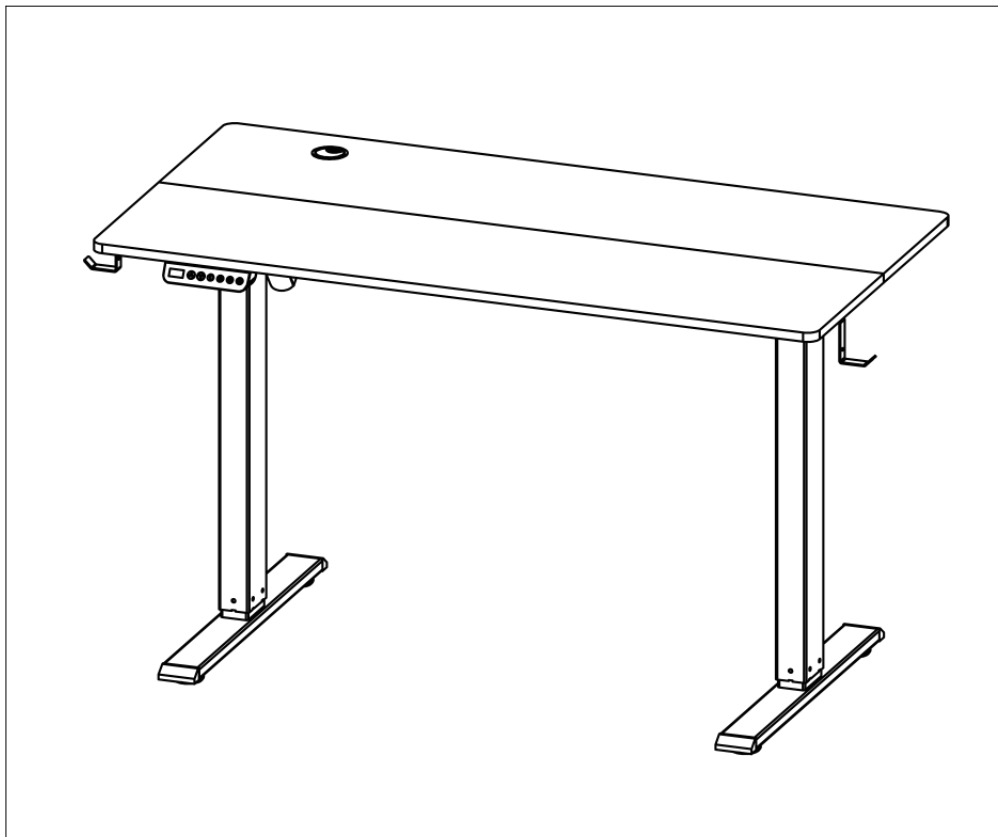

Indirizzo: Shuangchenglu 803nong11hao1602A-1609shi, baoshanqu,
shanghai 200000 CN.

Importato A Stati Uniti d'America : Sangue Tecnologia Società a
responsabilità limitata . , stanza 250 , 9166 Roma posto , ranch cucamonga , CA
91730

| | |
|-----------|------------|
| EC | REP |
|-----------|------------|

Azienda: E-CrossStu GmbH.

Via del paese di Magonza 69, 60329 Francoforte
sul Meno Principale.

| | |
|-----------|------------|
| UK | REP |
|-----------|------------|

CONSULENZA YH LIMITATO.

Consulenza C/OYH Ufficio limitato 147, Centurione
Casa, Londra Strada, Staines-upon-Thames, Surrey,
TW184AX

VEVOR®

TOUGH TOOLS, HALF PRICE

Supporto tecnico e Certificato di garanzia
elettronica www.vevor.com/support