

VEVOR[®]

TOUGH TOOLS, HALF PRICE

Technical Support and E-Warranty Certificate www.vevor.com/support

KITCHEN ISLAND USER MANUAL

MODEL:SR221264

We continue to be committed to provide you tools with competitive price.

"Save Half", "Half Price" or any other similar expressions used by us only represents an estimate of savings you might benefit from buying certain tools with us compared to the major top brands and does not necessarily mean to cover all categories of tools offered by us. You are kindly reminded to verify carefully when you are placing an order with us if you are actually saving half in comparison with the top major brands.

VEVOR®

TOUGH TOOLS, HALF PRICE

**KITCHEN ISLAND
(MODEL:SR221264)**

Thanks for purchasing one of our products, please read carefully the assembly instructions before the installation.

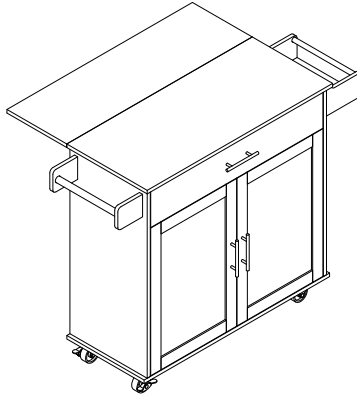

Model: SR221264

NEED HELP? CONTACT US!

Have product questions? Need technical support? Please feel free to contact us:

Technical Support and E-Warranty Certificate

www.vevor.com/support

This is the original instruction, please read all manual instructions carefully before operating. VEVOR reserves a clear interpretation of our user manual. The appearance of the product shall be subject to the product you received. Please forgive us that we won't inform you again if there are any technology or software updates on our product.

PRODUCT PARAMETERS

Model	ProductSize/mm (When the folding board is opened)	Loading Capacity	Top panel size(mm)
SR221264	1190x695x905	200 lb (Max)	900x390 900x290 (Folding board)

ASSEMBLY PRECAUTIONS

1. Assemble needs to follow these instructions. Incorrect assembly can be a hazard.
2. Wear safety goggles and heavy-duty work gloves during assembly.
3. Do not assemble when tired or under the influence of alcohol, drugs or medication.
4. Weight capacity and other product capabilities only apply to a wholly and correctly assembled product.
5. Keep the assembly area clean and well-lit.
6. Keep bystanders out of the area during assembly.
7. The weight of plate is heavy; pay attention to the installation to avoid hurting it, and if necessary, find someone to assist with the installation.

Assembling this cart will take approximately 2 hours, it is recommended that 2 people operate it.

USE PRECAUTIONS





WARNING: TO PREVENT SERIOUS INJURY AND DEATH FROM TIPPING:

1. This product is not a toy. Do not allow children to play with or approach this item.
2. Use as intended only. Do not sit or stand on the product.
3. Inspect before every use. Do not use it if parts are loose or damaged.
4. Use on flat, level, and hard surfaces only.
5. Do not exceed the listed weight capacity. Tighten all knobs securely before applying load. Be aware of dynamic loading! The sudden load movement may briefly create an excess load, causing product failure.

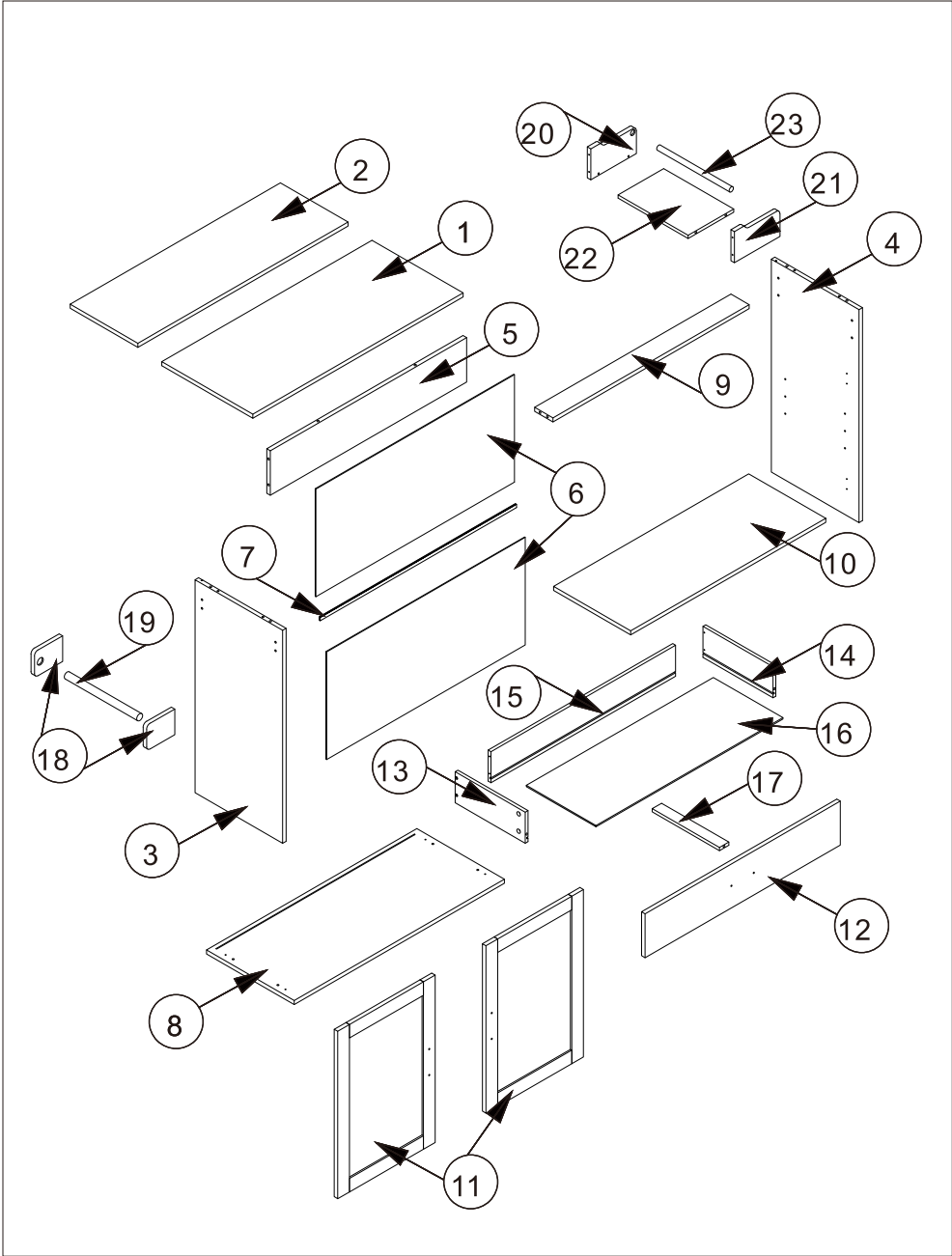



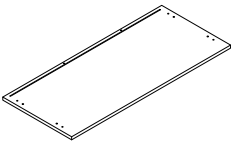
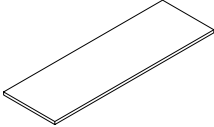
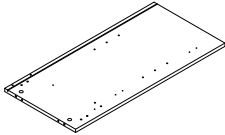
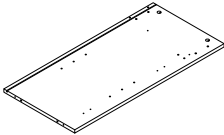
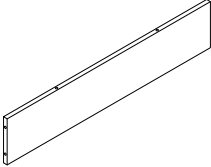
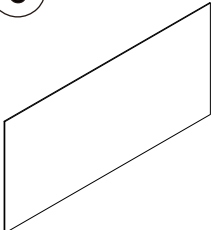
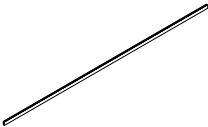
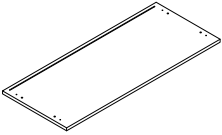
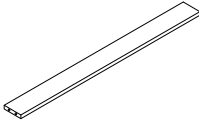
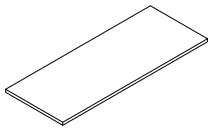
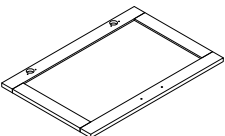
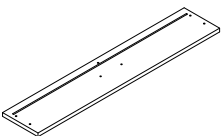

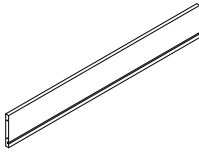
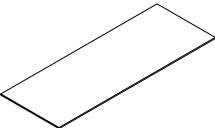

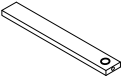
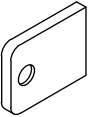
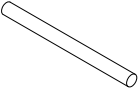
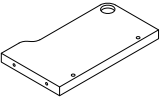
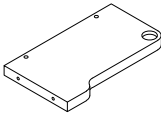
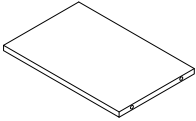
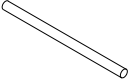











Exploded Drawing

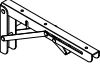

PARTS LIST

<p>1</p>  <p>1 PC</p>	<p>2</p>  <p>1 PC</p>	<p>3</p>  <p>1 PC</p>	<p>4</p>  <p>1 PC</p>
<p>5</p>  <p>1 PC</p>	<p>6</p>  <p>2 PCS</p>	<p>7</p>  <p>1 PC</p>	<p>8</p>  <p>1 PC</p>
<p>9</p>  <p>1 PC</p>	<p>10</p>  <p>1 PC</p>	<p>11</p>  <p>2 PCS</p>	<p>12</p>  <p>1 PC</p>
<p>13</p>  <p>1 PC</p>	<p>14</p>  <p>1 PC</p>	<p>15</p>  <p>1 PC</p>	<p>16</p>  <p>1 PC</p>

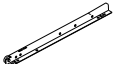
<p>17</p>  <p>1 PC</p>	<p>18</p>  <p>2 PCS</p>	<p>19</p>  <p>1 PC</p>	<p>20</p>  <p>1 PC</p>
<p>21</p>  <p>1 PC</p>	<p>22</p>  <p>1 PC</p>	<p>23</p>  <p>1 PC</p>	

A M6*35  23 PCS +1spare	B Ø15*10  23 PCS +1spare	C Ø6*30  8 PCS	D M4*35  4 PCS	E M4*20  6 PCS	F  3 PCS	G M3*12  8 PCS	H M7*40  8 PCS
I M5*14  26 PCS +1spare	J  2 PCS	K  2 PCS	L M4*30  5 PCS	M M4*14  24 PCS +1spare	N  4 PCS	O  4 PCS	P  2 PCS
Q  1 PC	CL  1 PC	CR  1 PC	DL  1 PC	DR  1 PC			

Cam Lock Fastening System

This Cam Lock Fastening System will be used throughout the assembly process

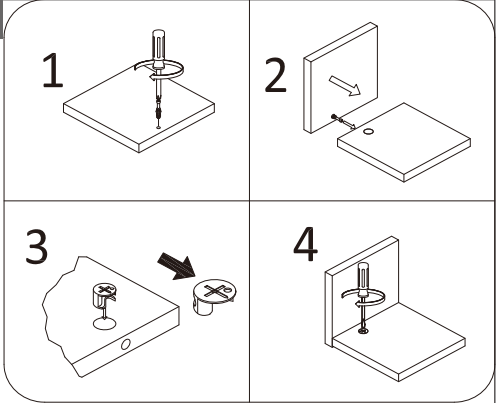
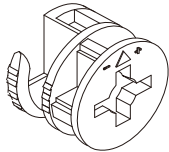

ASSEMBLY STEPS



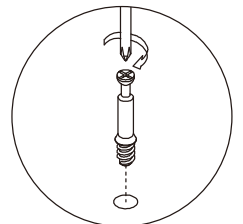
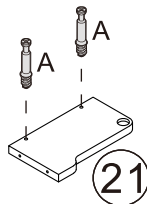
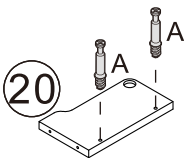
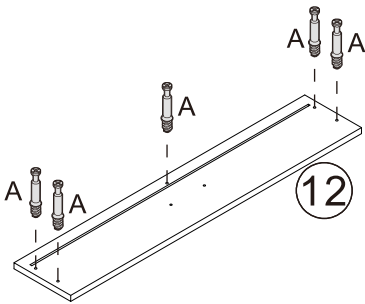
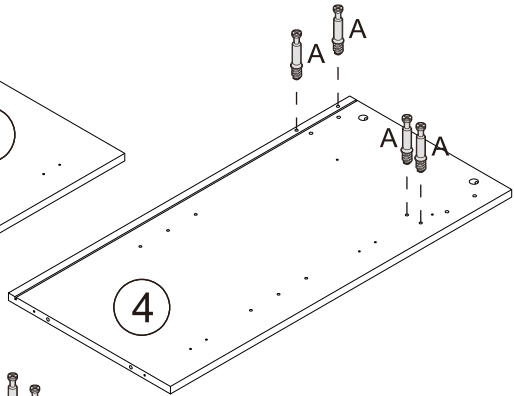
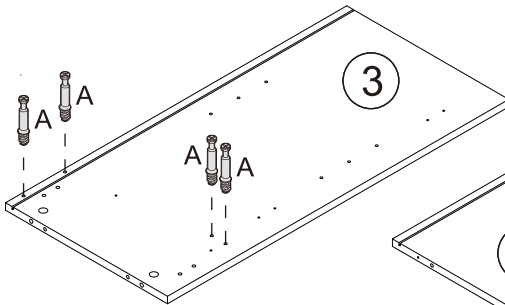
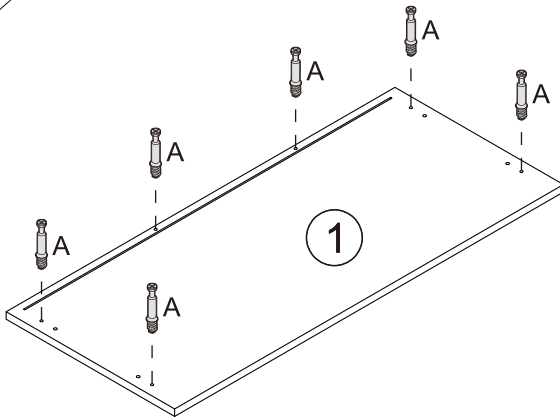

Ax23

1



2

	CL x1
	CR x1
 M3*12	G x4

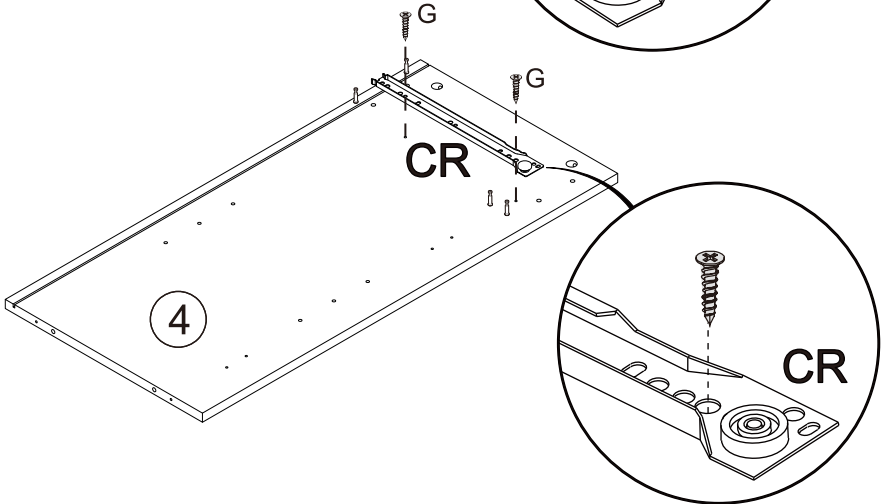
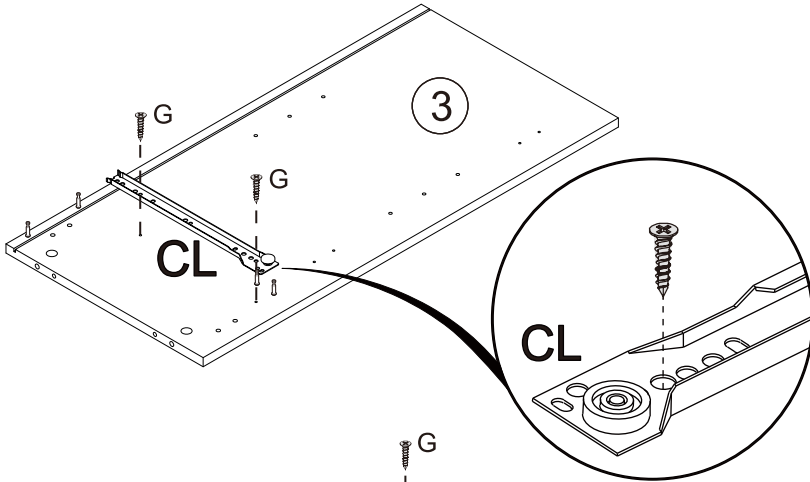

3

 $\varnothing 15 \times 10$ **Bx4**

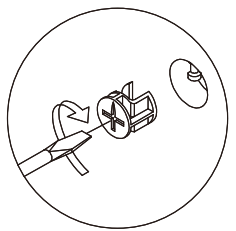
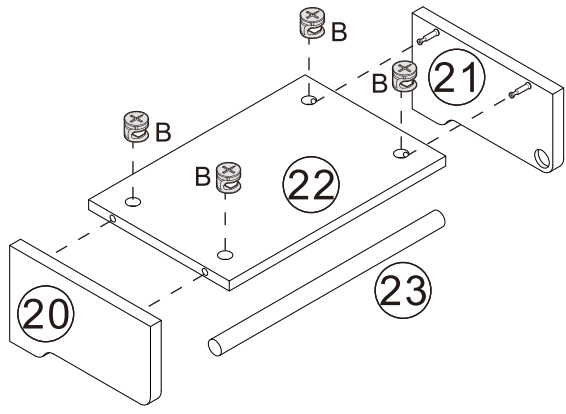

4

 M7x40 **Hx4**

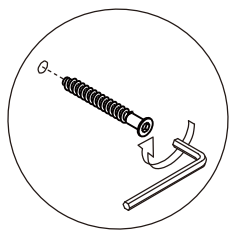
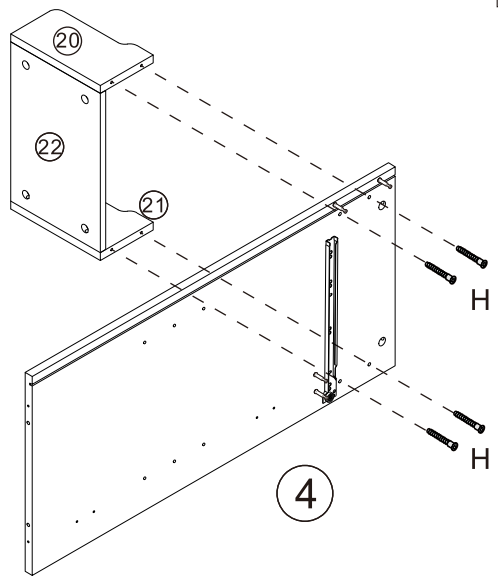

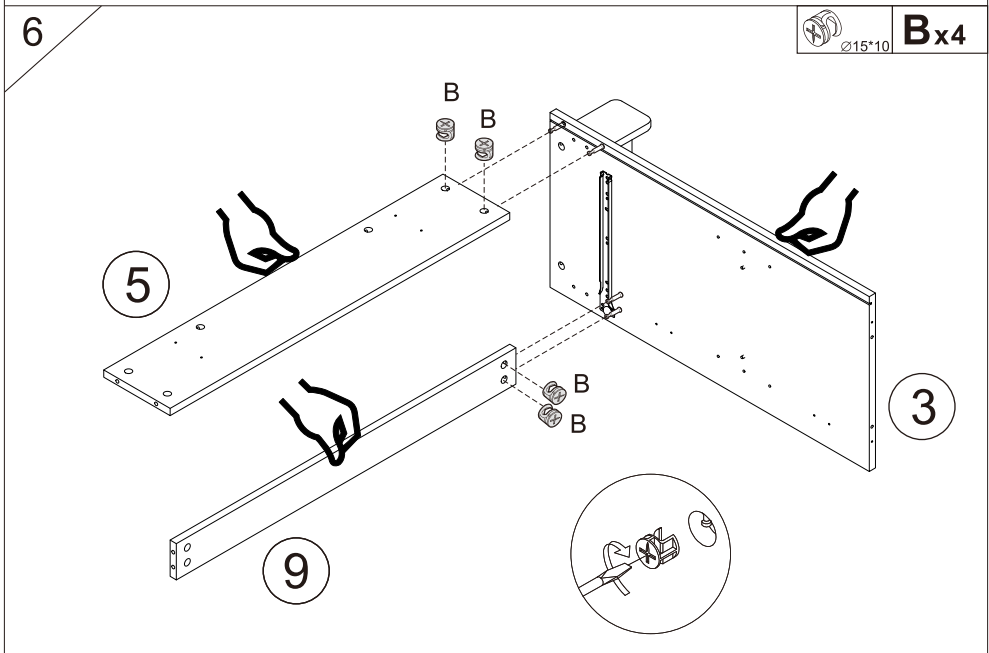
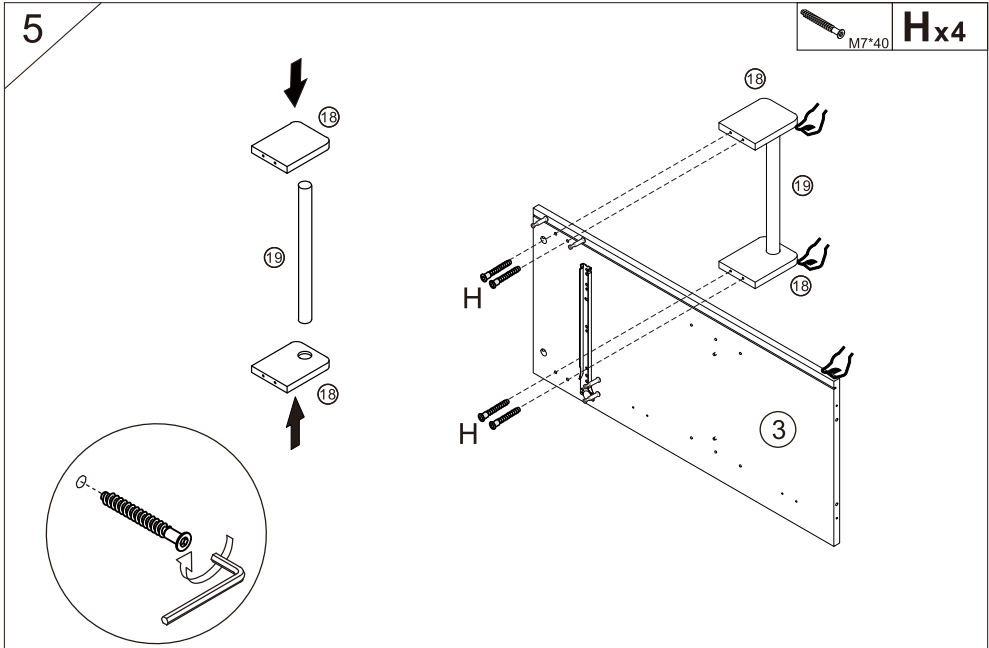

7



Bx4

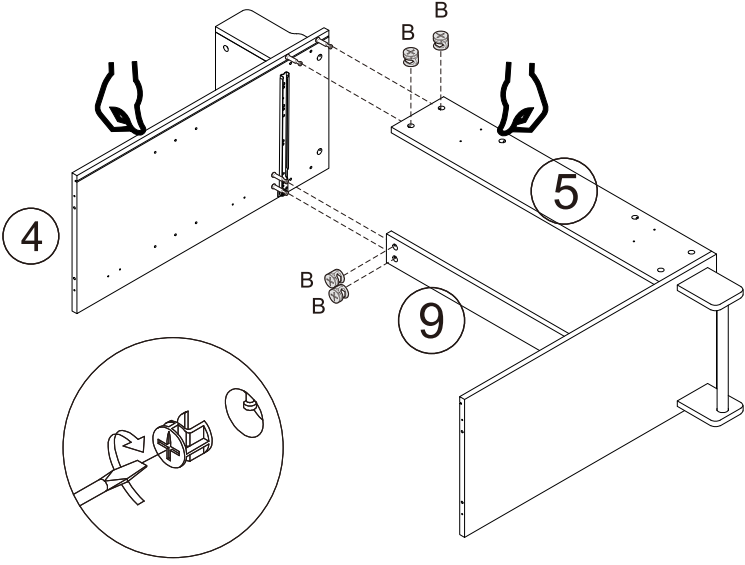

8

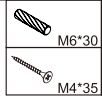

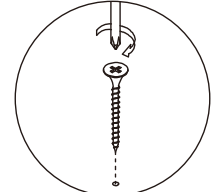
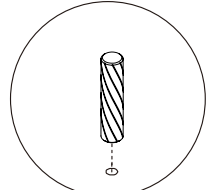
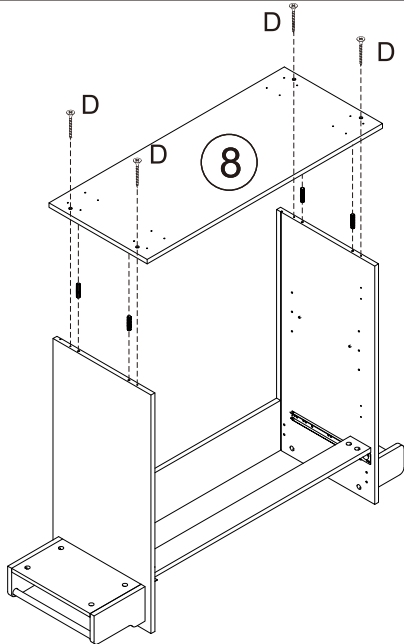

Cx4
Dx4

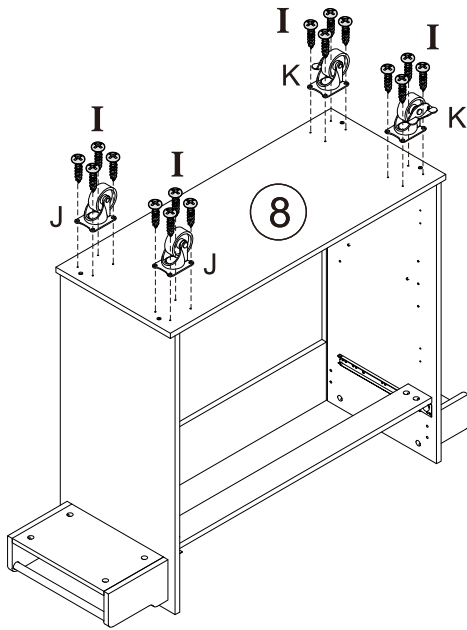

9



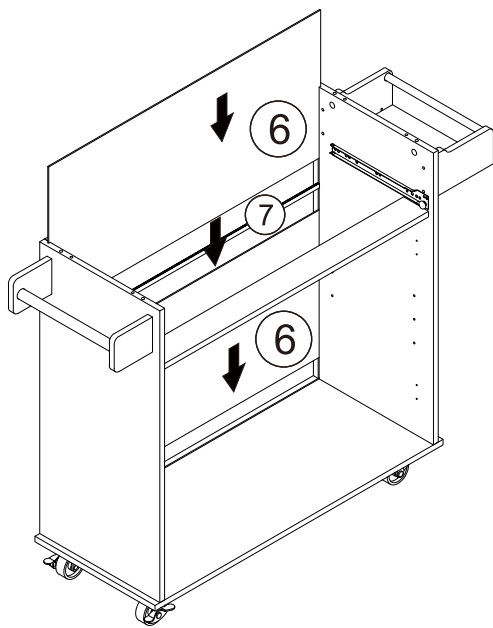

 M5*14	I x16
	J x2
	K x2

10

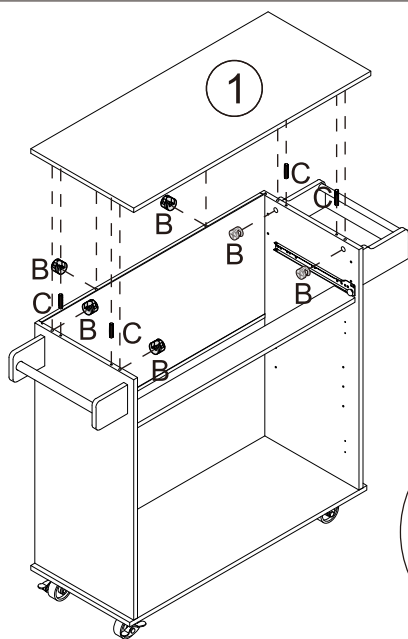

11



 $\varnothing 15 \times 10$	B x6
 M6 x 30	C x4

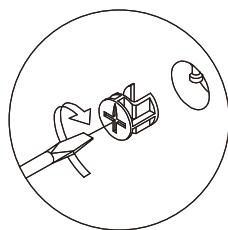
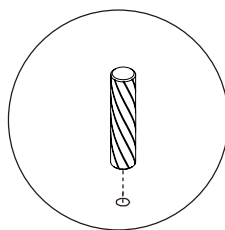

12

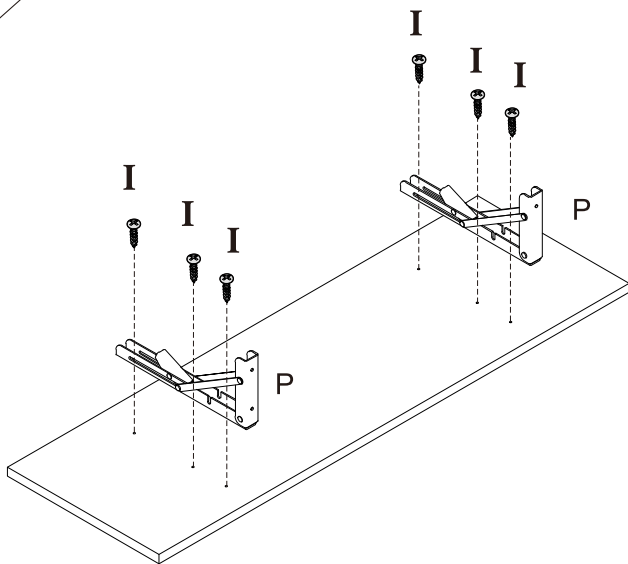

 M5 x 14	I x6
	P x2

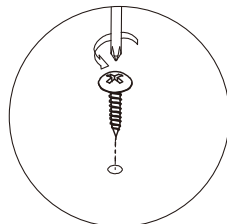
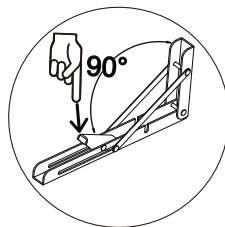

13

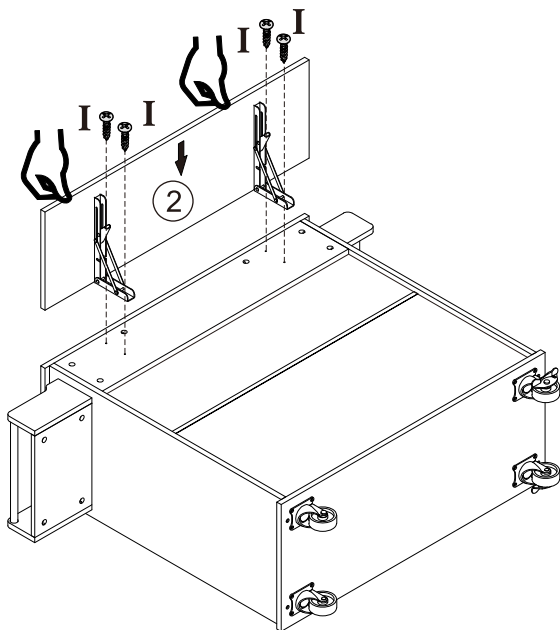

I x4

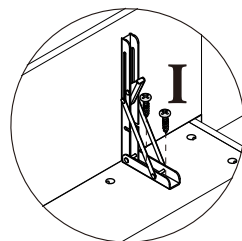
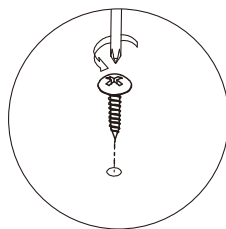

14

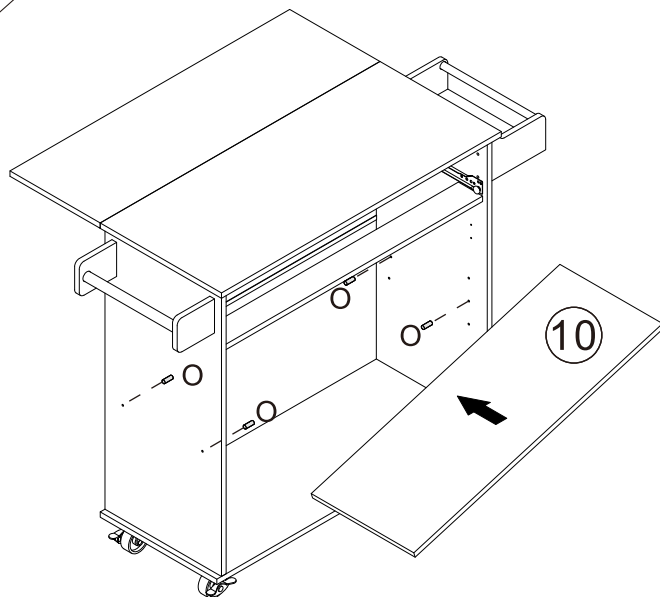

O x4

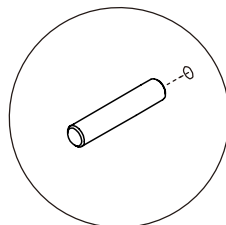



15

x2

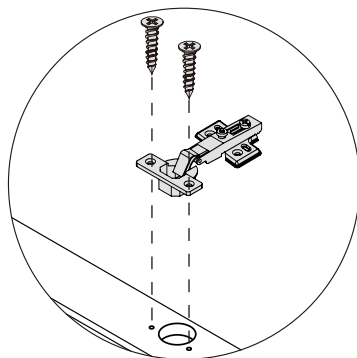
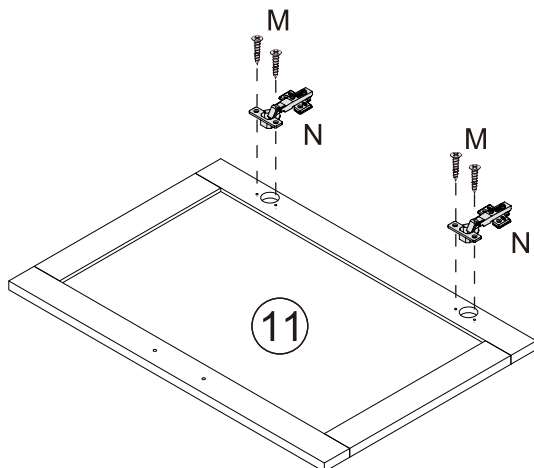
 M4*14	M x8
	N x4



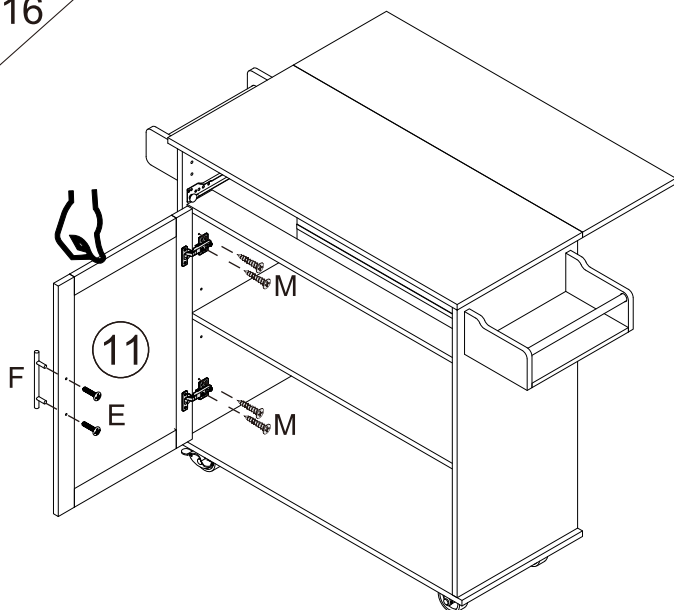

16

 M4*20	E x2
	F x1
 M4*14	M x4



17

 M4*20	E x2
	F x1
 M4*14	M x4

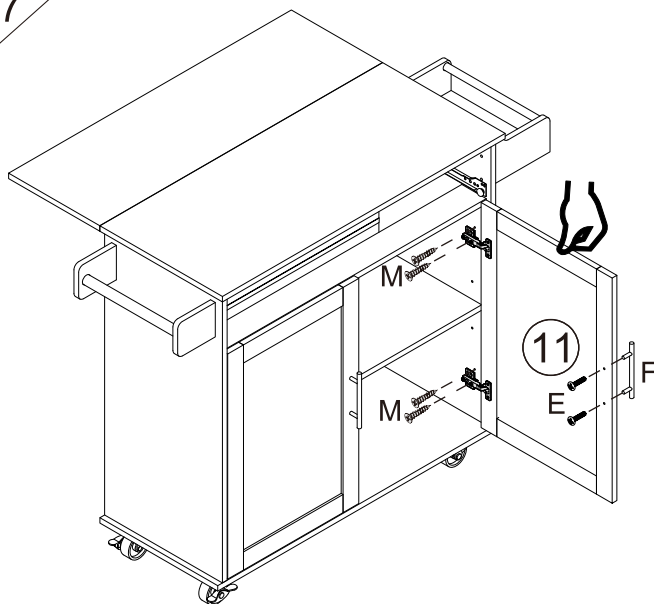

18

 M4*14	M x8
---	-------------

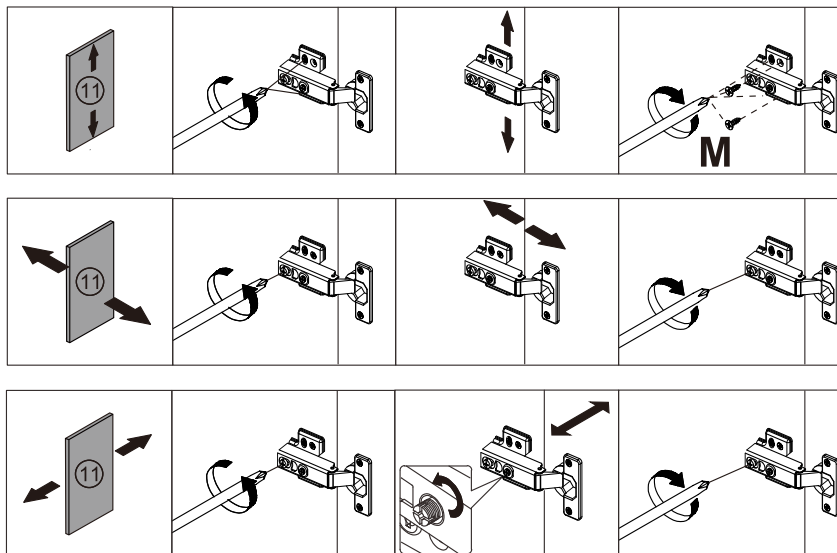





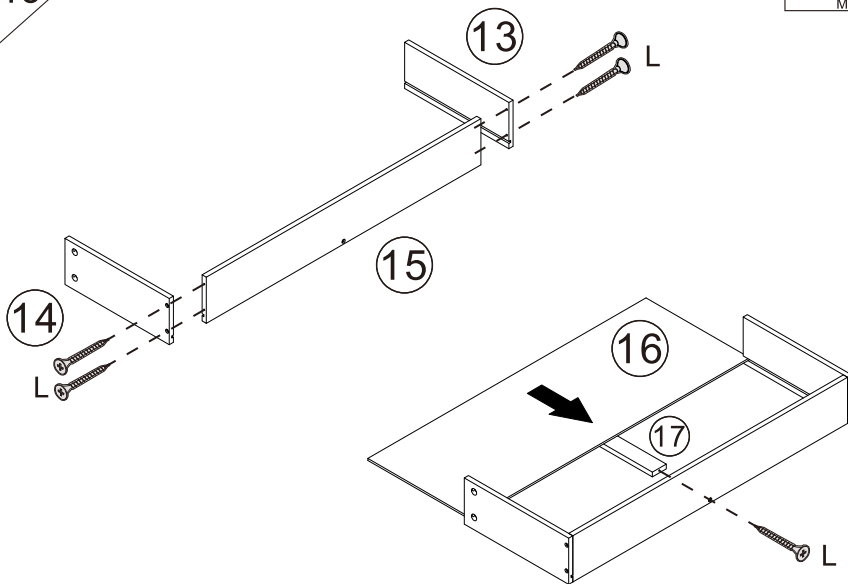

19

M4*30 **Lx5**



20

 $\varnothing 15 \times 10$	Bx5
 M4*20	Ex2
	Fx1
	DLx1
	DRx1
 M3*12	Gx4

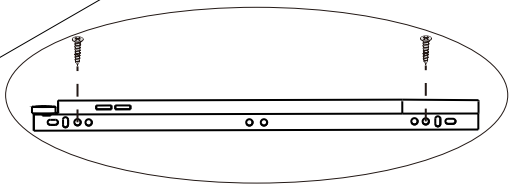
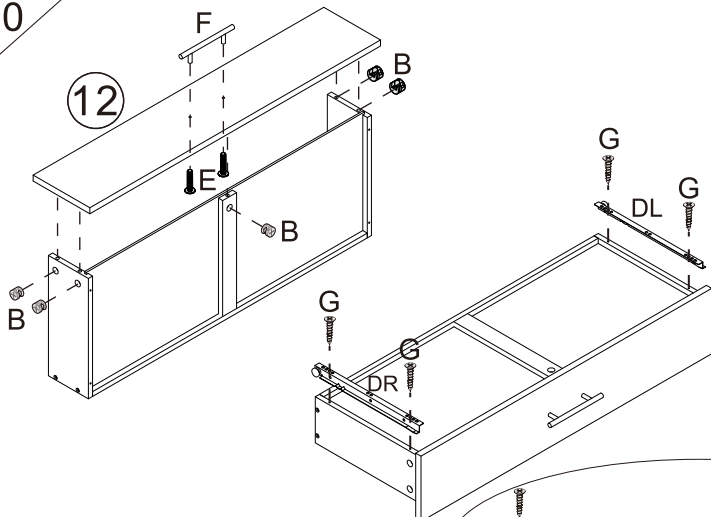

21

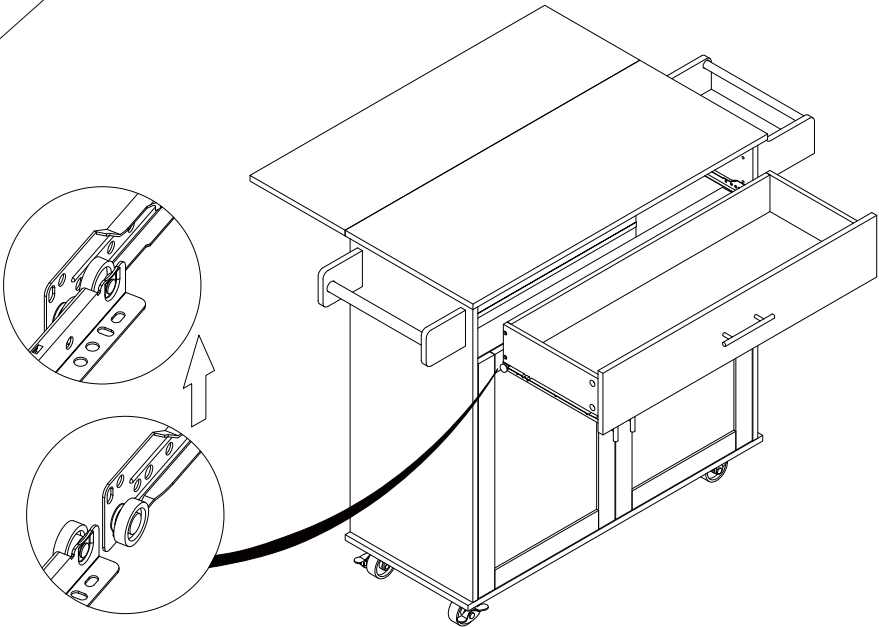

22

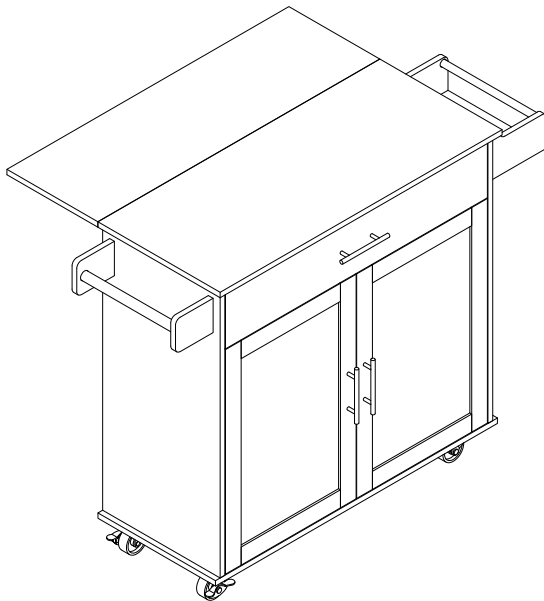

General Care

- 1. Make sure each layer should not exceed 40lb loading weight.
- 2. Make sure Folding board should not exceed 37lb loading weight.

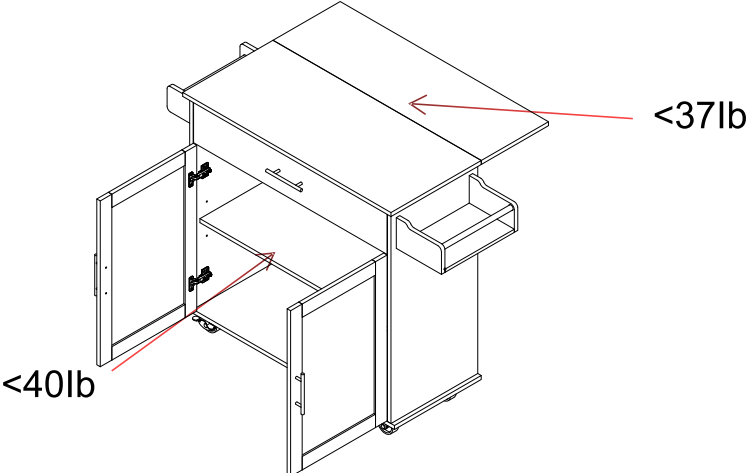

- 3. Make sure each drawer should not exceed 28lb loading weight.

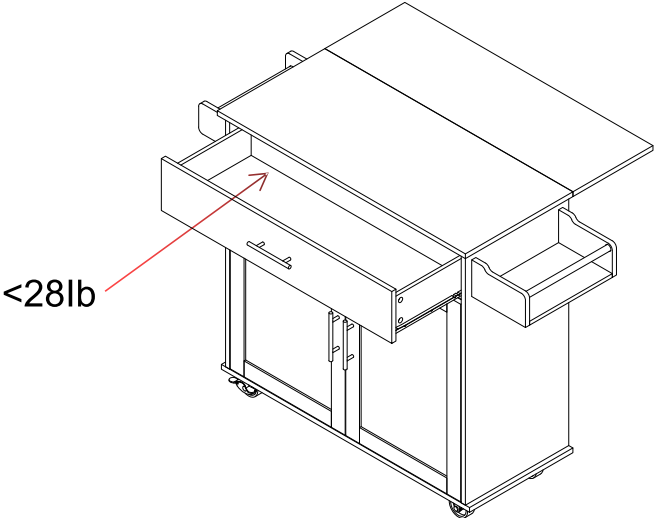

Cleaning

-For cleaning, wipe the surface with a damp (not wet) cloth or wipe dry with a clean lint free cotton cloth.

Manufacturer: Shanghaimuxinmuyeyouxiangongsi

Address: Shuangchenglu 803nong11hao1602A-1609shi, baoshanqu, shanghai 200000 CN.

Imported to AUS: SIHAO PTY LTD. 1 ROKEVA STREETEASTWOOD NSW 2122 Australia

Imported to USA: Sanven Technology Ltd. Suite 250, 9166 Anaheim Place, Rancho Cucamonga, CA 91730



E-CrossStu GmbH
Mainzer Landstr.69, 60329 Frankfurt am Main.



YH CONSULTING LIMITED.
C/O YH Consulting Limited Office 147, Centurion House,
London Road, Staines-upon-Thames, Surrey, TW18 4AX

VEVOR[®]

TOUGH TOOLS, HALF PRICE

Support and E-Warranty Certificate <https://www.vevor.com/support>

VEVOR[®]

TOUGH TOOLS, HALF PRICE

Technical Support and E-Warranty Certificate www.vevor.com/support

KITCHEN ISLAND USER MANUAL

MODEL:SR221264

We continue to be committed to provide you tools with competitive price.

"Save Half", "Half Price" or any other similar expressions used by us only represents an estimate of savings you might benefit from buying certain tools with us compared to the major top brands and it does not necessarily mean to cover all categories of tools offered by us. You are kindly reminded to verify carefully when you are placing an order with us if you are actually saving half in comparison with the top major brands.

VEVOR®

TOUGH TOOLS, HALF PRICE

**KITCHEN ISLAND
(MODEL:SR221264)**

Thanks for purchasing one of our products, please read carefully the assembly instructions before the installation.

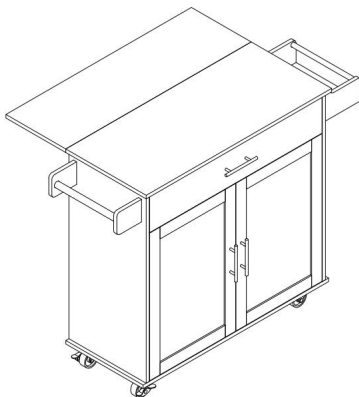

Model: SR221264

NEED HELP? CONTACT US!

Have product questions? Need technical support? Please feel free to contact us:

Assistance technique et certificat de garantie
électronique www.vevor.com/support

This is the original instruction, please read all manual instructions carefully before operating. VEVOR reserves a clear interpretation of our user manual. The appearance of the product shall be subject to the product you received. Please forgive us that we won't inform you again if there are any technology or software updates on our product.

PRODUCT PARAMETERS

Model	ProductSize/mm (When the folding board is opened)	Loading Capacity	Top panel size(mm)
SR221264	1190x695x905	200 lb (Max)	900x390 900x290 (Folding board)

ASSEMBLY PRECAUTIONS

1. Assemble needs to follow these instructions. Incorrect assembly can be a hazard.
2. Wear safety goggles and heavy-duty work gloves during assembly.
3. Do not assemble when tired or under the influence of alcohol, drugs or medication.
4. Weight capacity and other product capabilities only apply to a wholly and correctly assembled product.
5. Keep the assembly area clean and well-lit.
6. Keep bystanders out of the area during assembly.
7. The weight of plate is heavy; pay attention to the installation to avoid hurting it, and if necessary, find someone to assist with the installation.

L'assemblage de ce chariot prendra environ 2 heures, il est recommandé que 2 personnes l'utilisent.

USE PRECAUTIONS





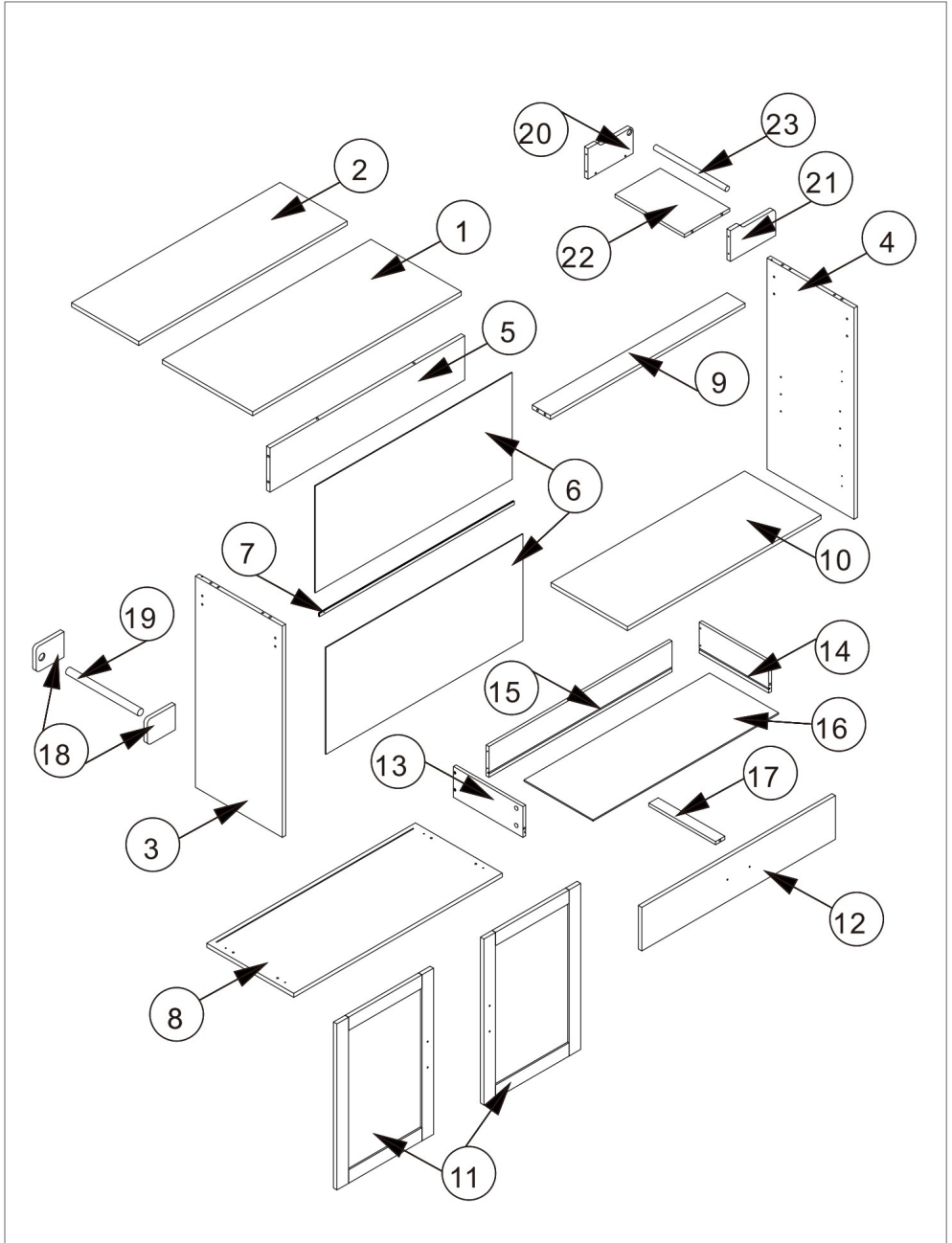

WARNING: TO PREVENT SERIOUS INJURY AND DEATH FROM TIPPING:

1. This product is not a toy. Do not allow children to play with or approach this item.
2. Use as intended only. Do not sit or stand on the product.
3. Inspect before every use. Do not use it if parts are loose or damaged.
4. Use on flat, level, and hard surfaces only.
5. Do not exceed the listed weight capacity. Tighten all knobs securely before applying load. Be aware of dynamic loading! The sudden load movement may briefly create an excess load, causing product failure.



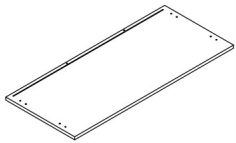
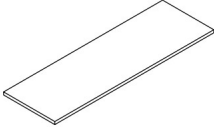
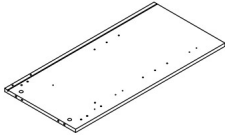
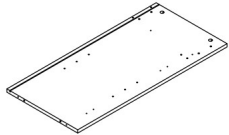
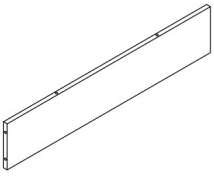
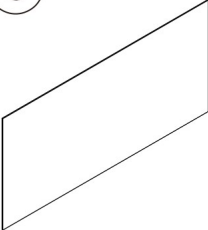

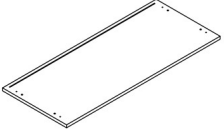
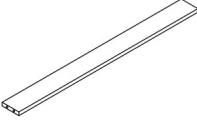
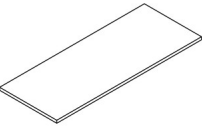
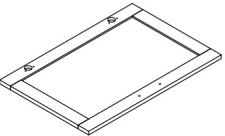
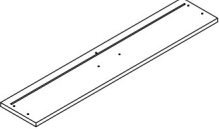

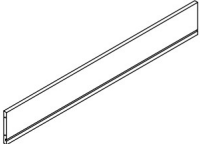
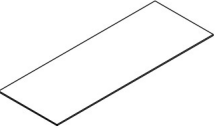

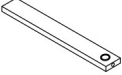
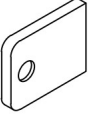
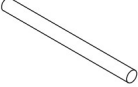
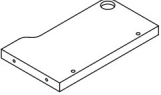
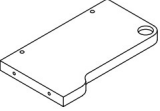
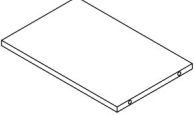
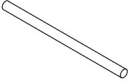











Exploded Drawing



PARTS LIST

<p>1</p>  <p>1 PC</p>	<p>2</p>  <p>1 PC</p>	<p>3</p>  <p>1 PC</p>	<p>4</p>  <p>1 PC</p>
<p>5</p>  <p>1 PC</p>	<p>6</p>  <p>2 PCS</p>	<p>7</p>  <p>1 PC</p>	<p>8</p>  <p>1 PC</p>
<p>9</p>  <p>1 PC</p>	<p>10</p>  <p>1 PC</p>	<p>11</p>  <p>2 PCS</p>	<p>12</p>  <p>1 PC</p>
<p>13</p>  <p>1 PC</p>	<p>14</p>  <p>1 PC</p>	<p>15</p>  <p>1 PC</p>	<p>16</p>  <p>1 PC</p>

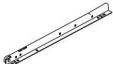
<p>17</p>  <p>1 PC</p>	<p>18</p>  <p>2 PCS</p>	<p>19</p>  <p>1 PC</p>	<p>20</p>  <p>1 PC</p>
<p>21</p>  <p>1 PC</p>	<p>22</p>  <p>1 PC</p>	<p>23</p>  <p>1 PC</p>	

A M6*35  23 PCS <small>*1 de rechange</small>	B Ø15*10  23 PCS <small>*1 de rechange</small>	C Ø6*30  8 PCS	D M4*35  4 PCS	E M4*20  6 PCS	F  3 PCS	G M3*12  8 PCS	H M7*40  8 PCS
I M5*14  26 PCS <small>*1 de rechange</small>	J  2 PCS	K  2 PCS	L M4*30  5 PCS	M M4*14  24 PCS <small>*1 de rechange</small>	N  4 PCS	O  4 PCS	P  2 PCS
Q  1 PC	CL  1 PC	CR  1 PC	DL  1 PC	DR  1 PC			

Cam Lock Fastening System

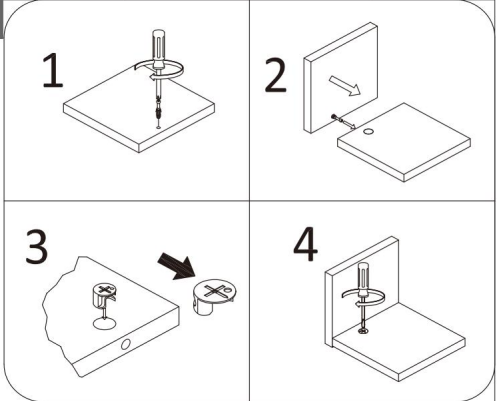
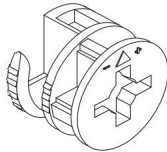

This Cam Lock Fastening System will be used throughout the assembly process

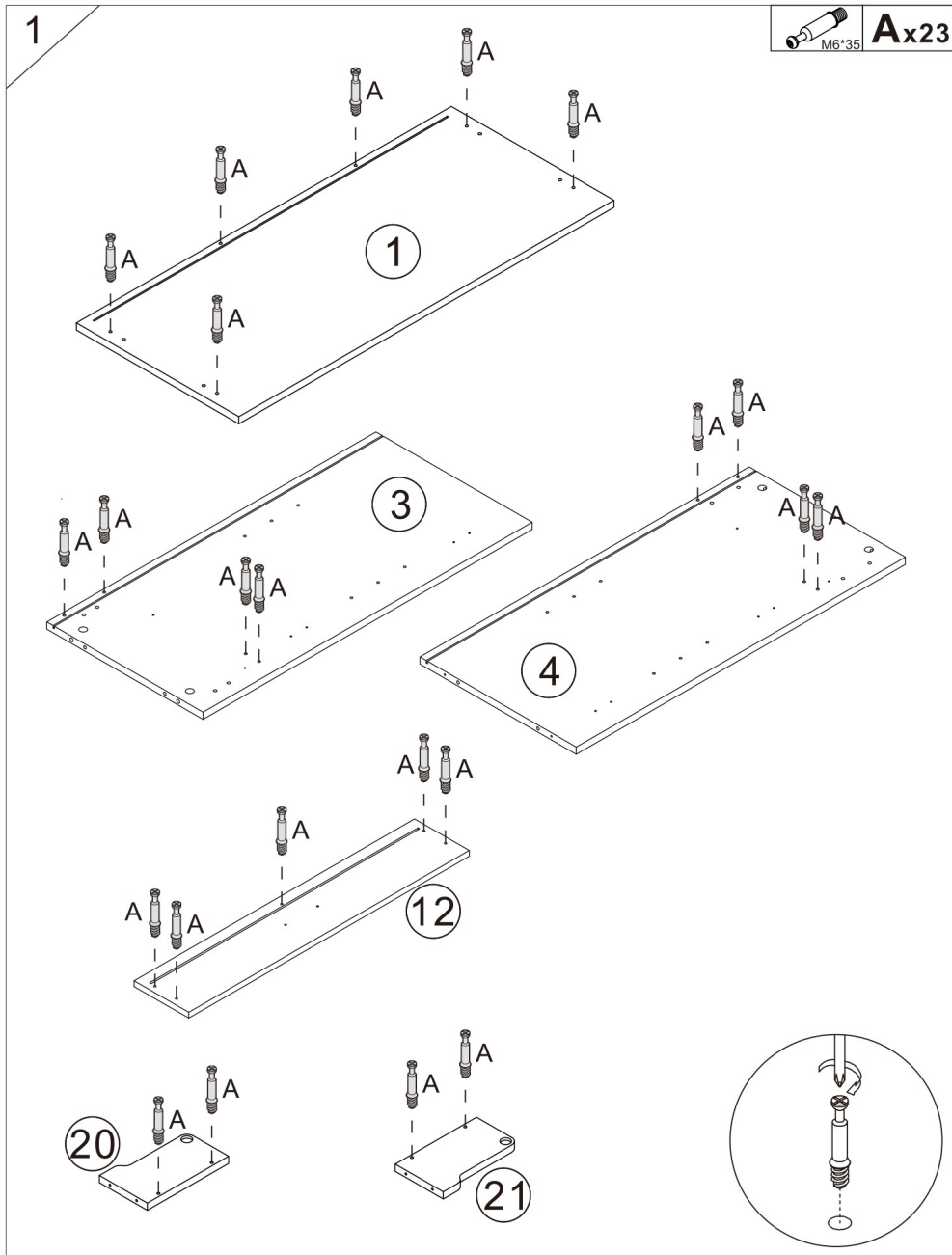

ASSEMBLY STEPS



2

	CLx1
	CRx1
 M3*12	Gx4

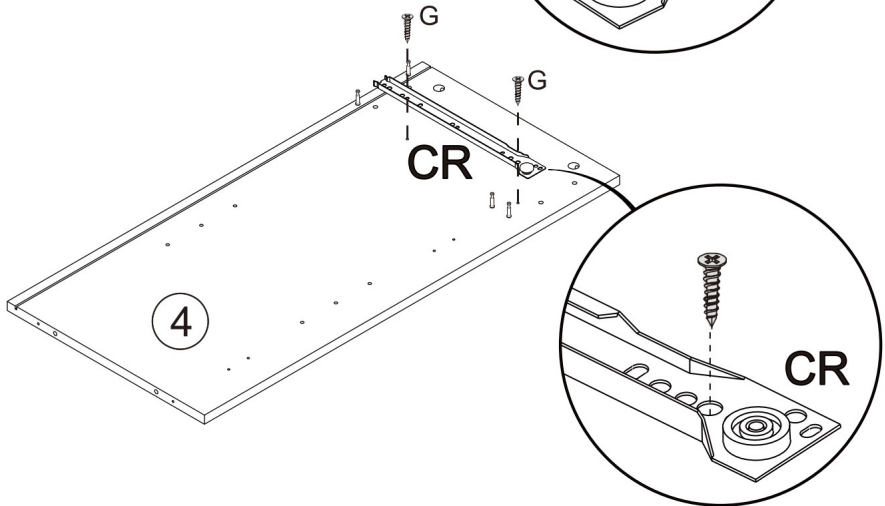
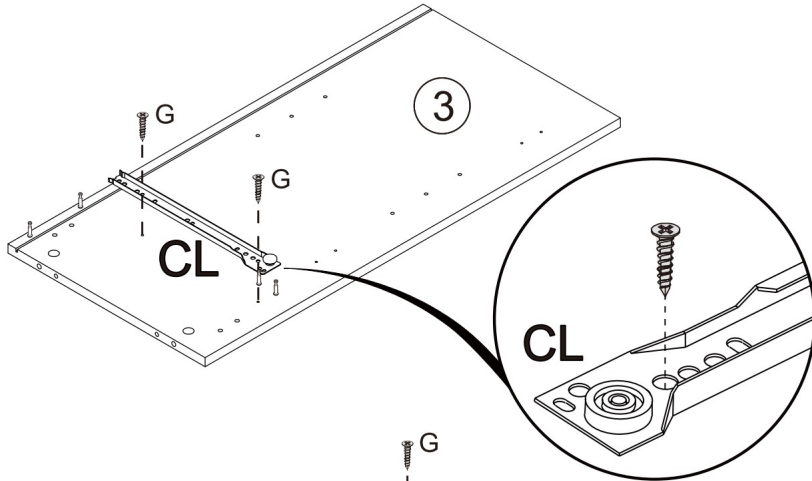

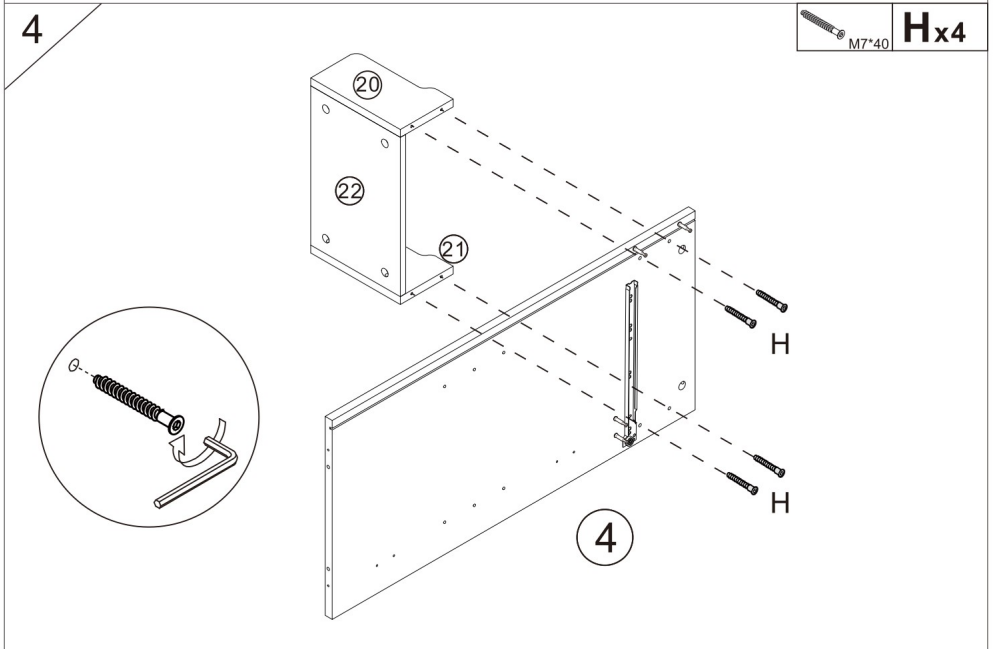
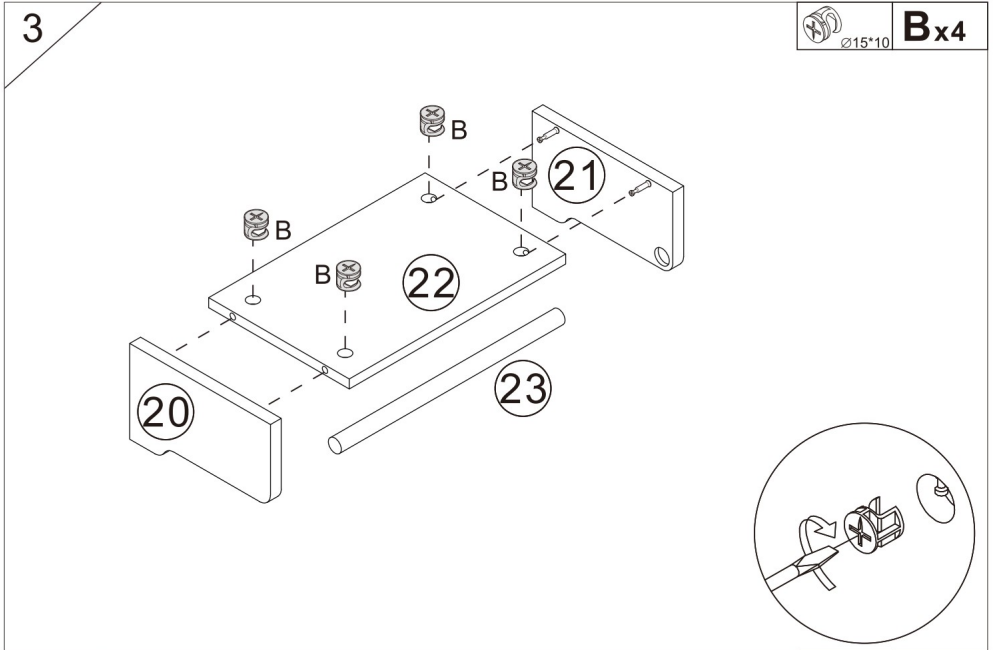

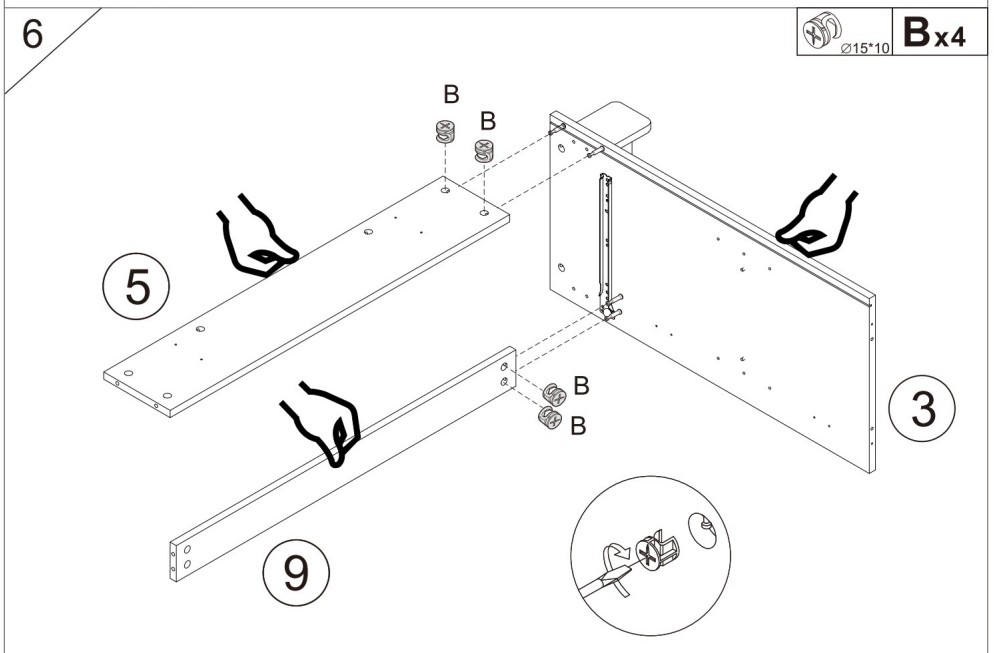
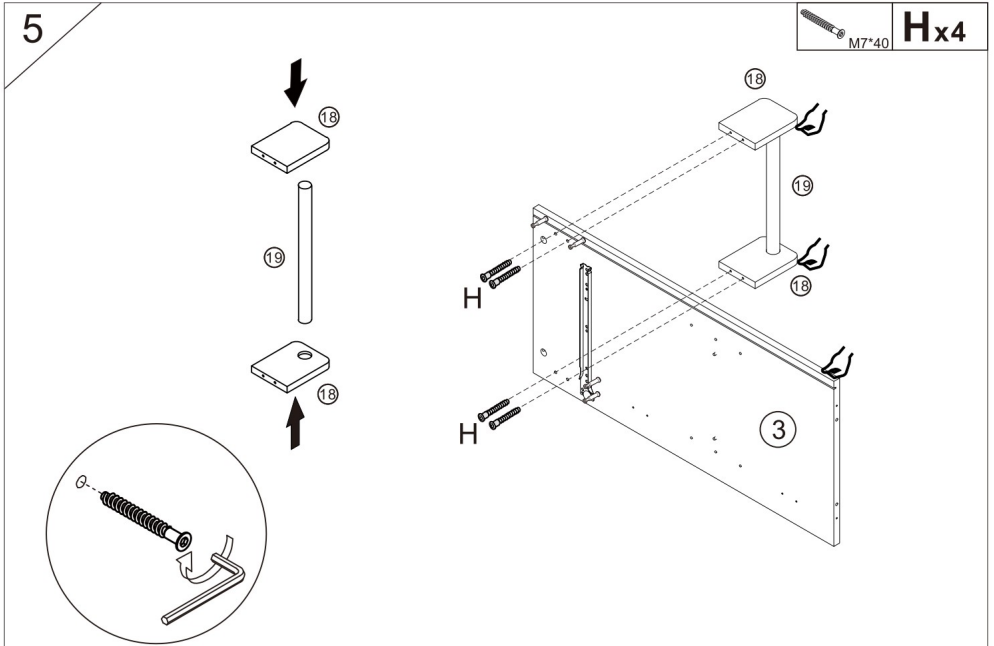

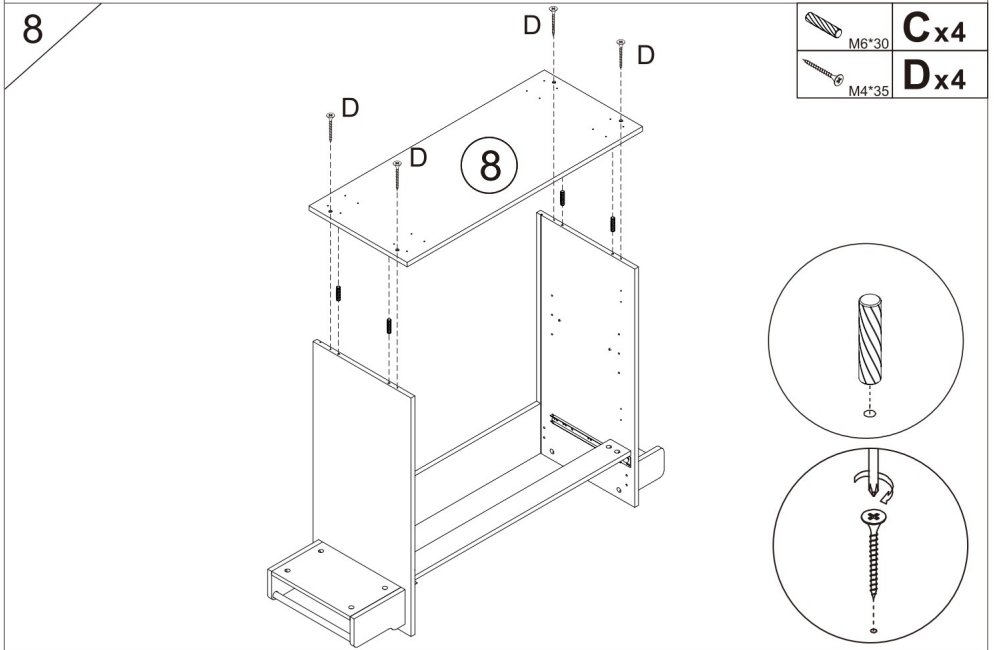
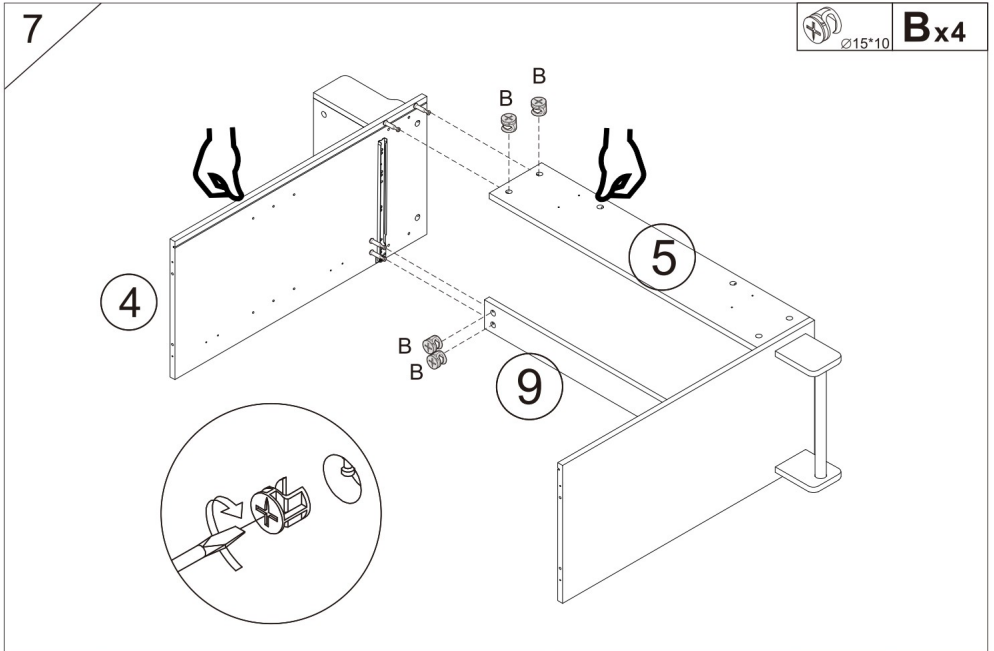

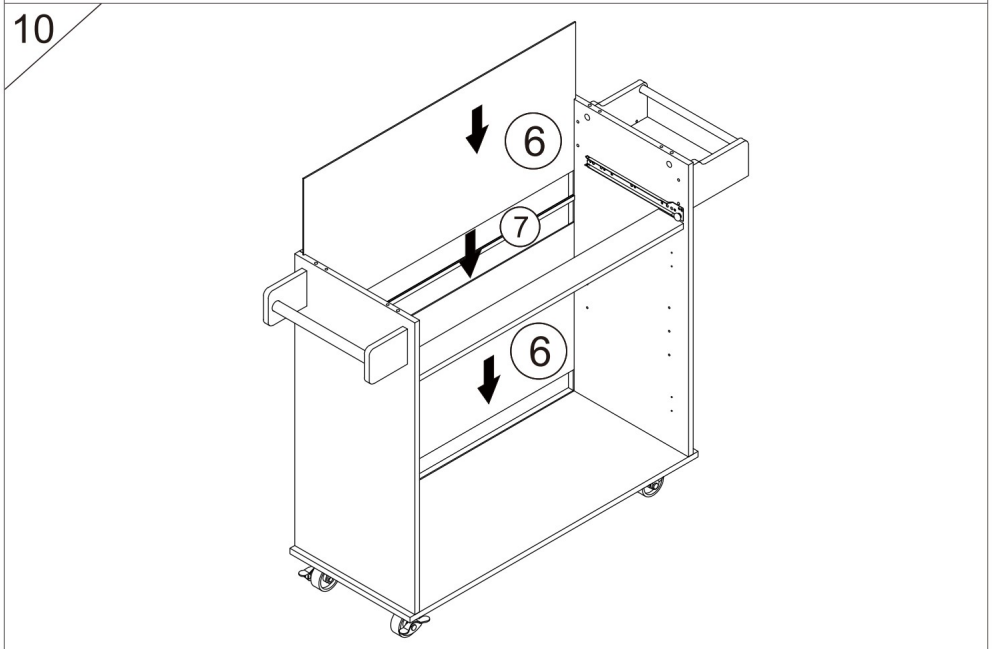
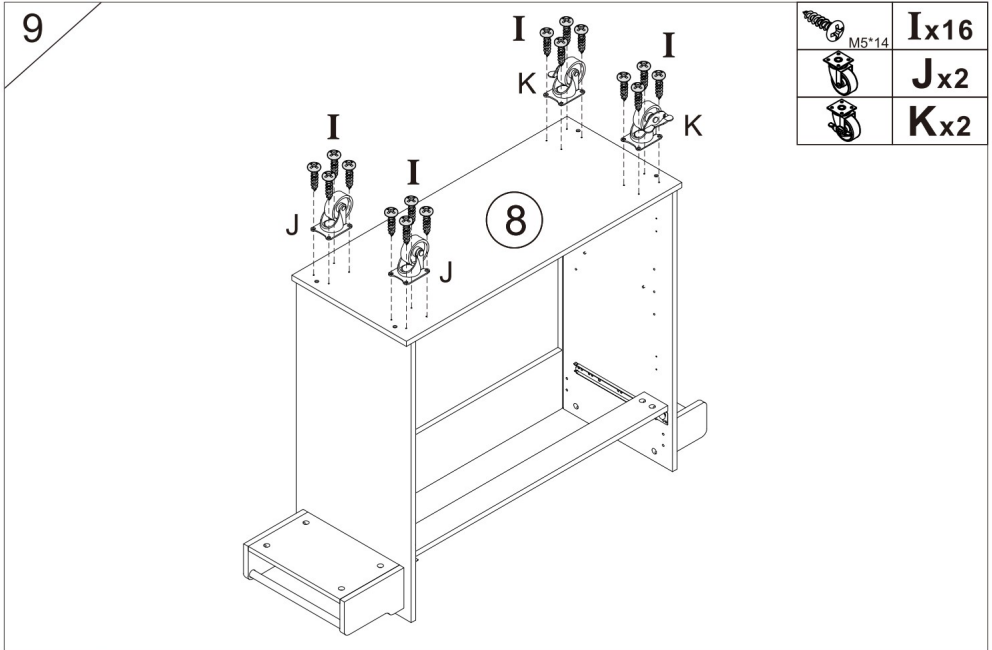

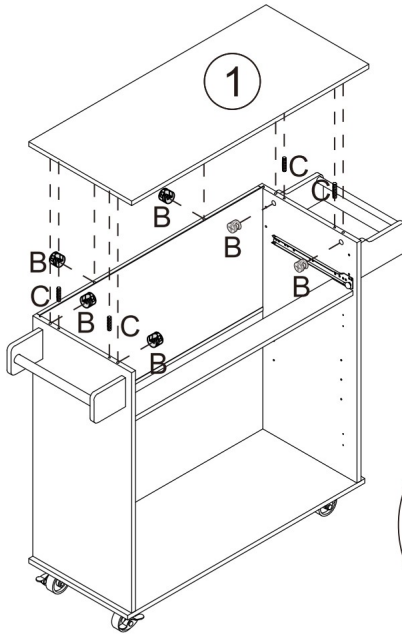

11



 Ø15*10	Bx6
 M6*30	Cx4

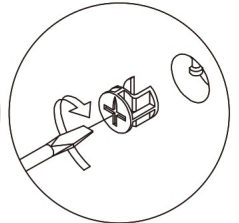
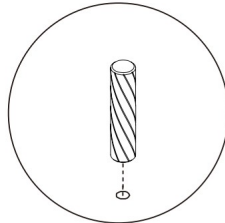

12

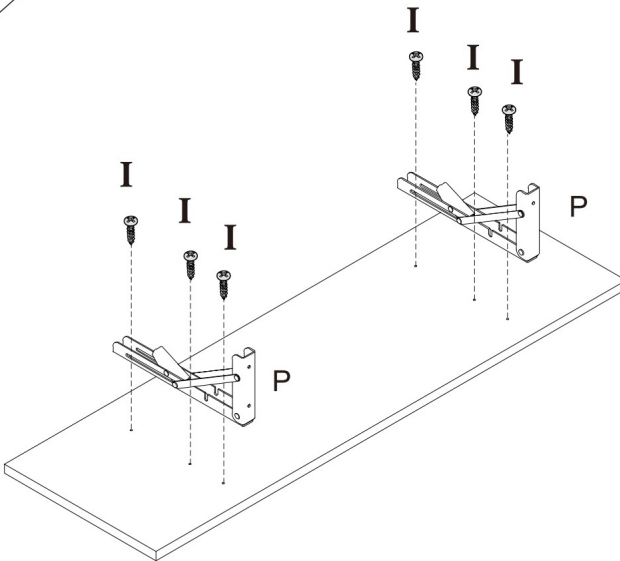

 M5*14	Ix6
	Px2

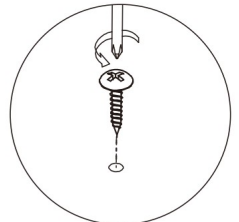
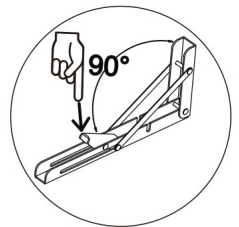

13

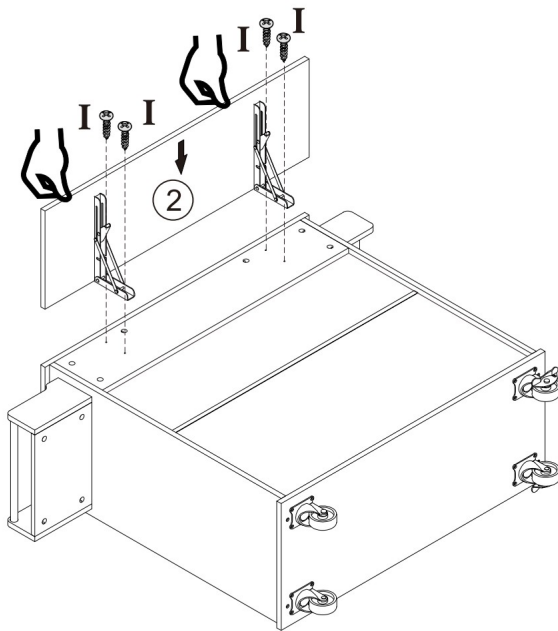

M5*14 I x4

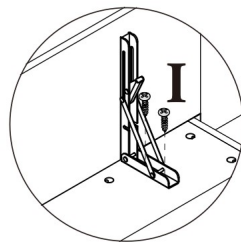
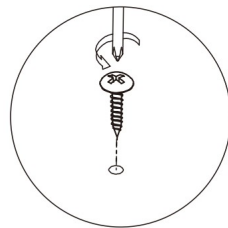

14

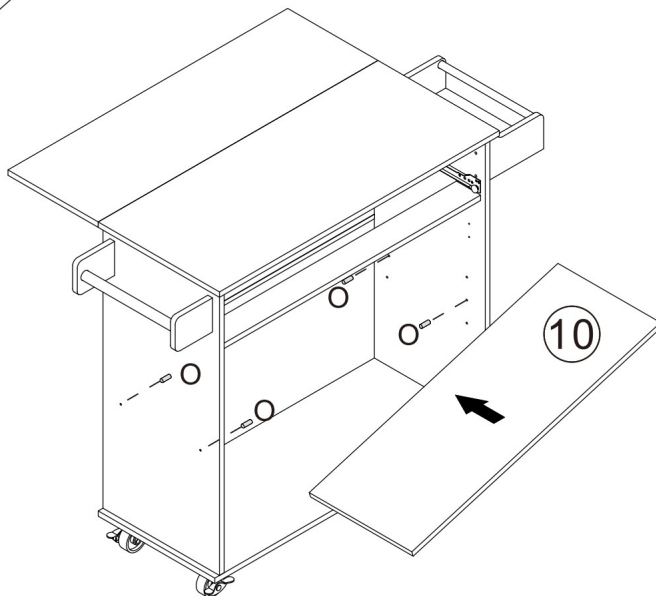

O x4

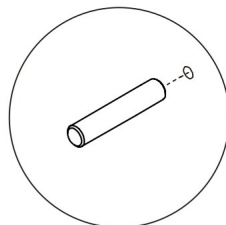



15

x2

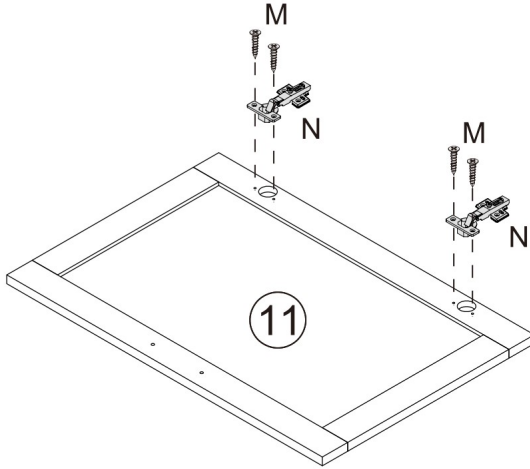
 M4*14	Mx8
	Nx4



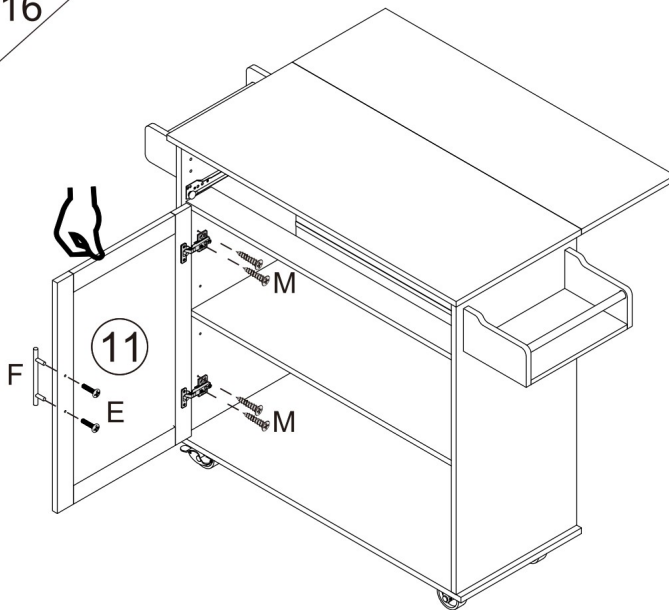

16

 M4*20	Ex2
	Fx1
 M4*14	Mx4



17

 M4*20	E x2
	F x1
 M4*14	M x4

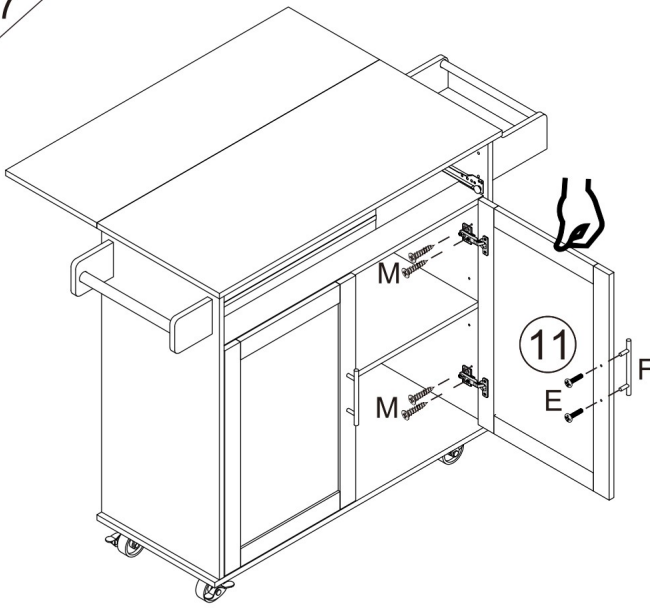

18

 M4*14	M x8
---	-------------

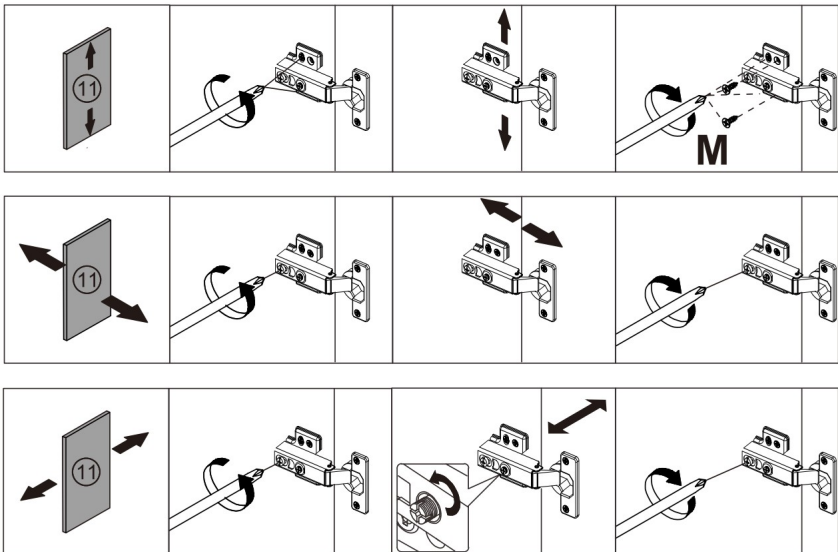

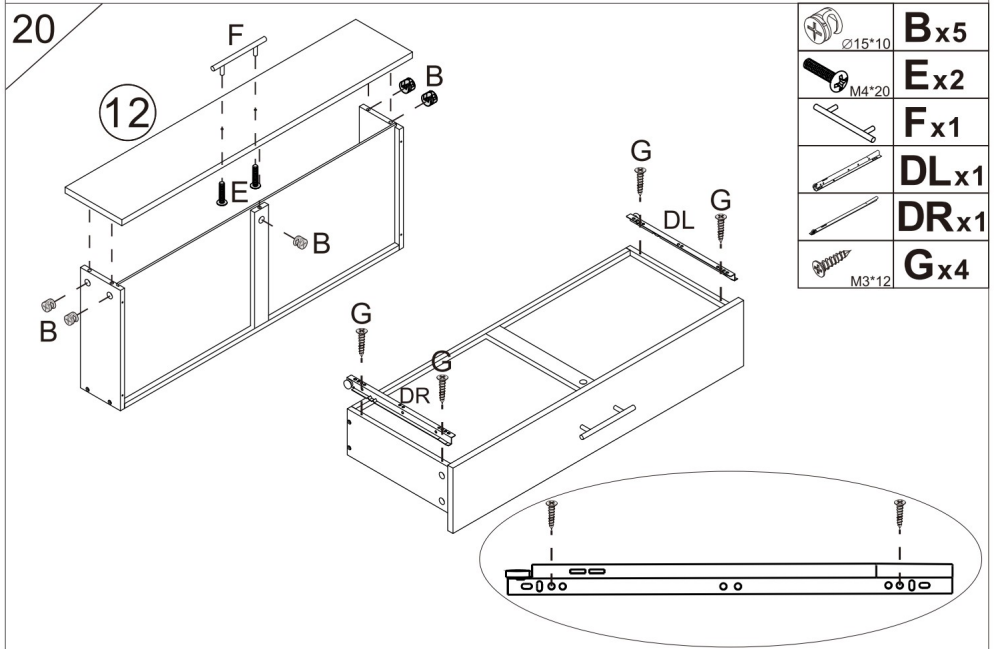
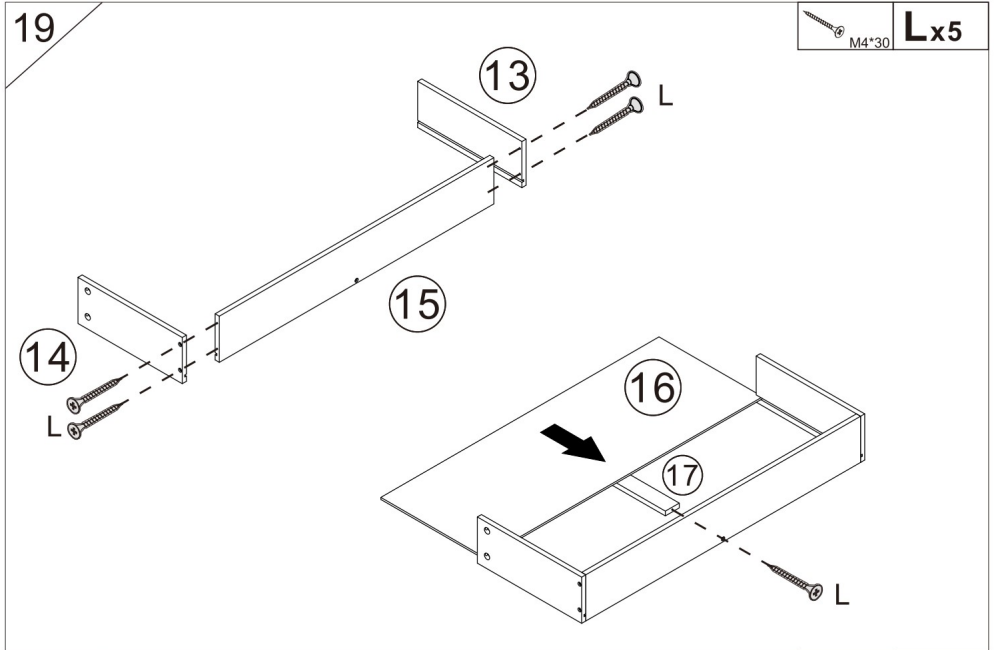

21

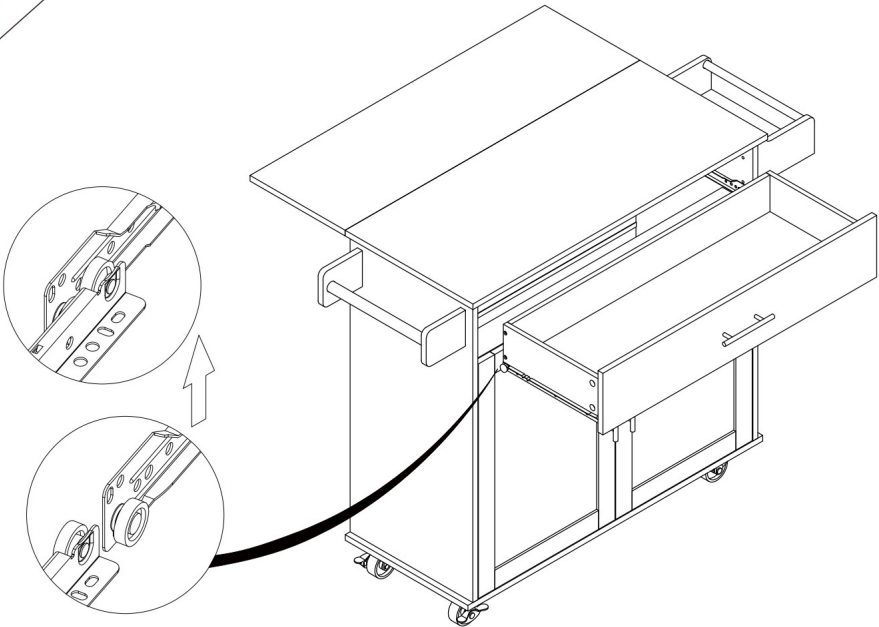

22

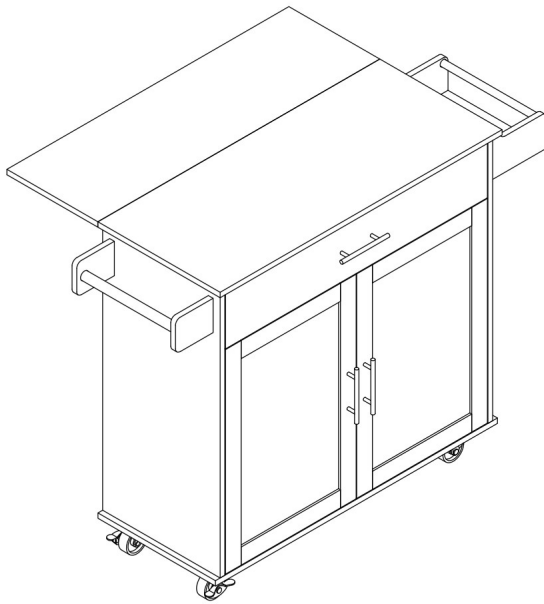

General Care

1. Make sure each layer should not exceed 40lb loading weight.
2. Make sure Folding board should not exceed 37lb loading weight.

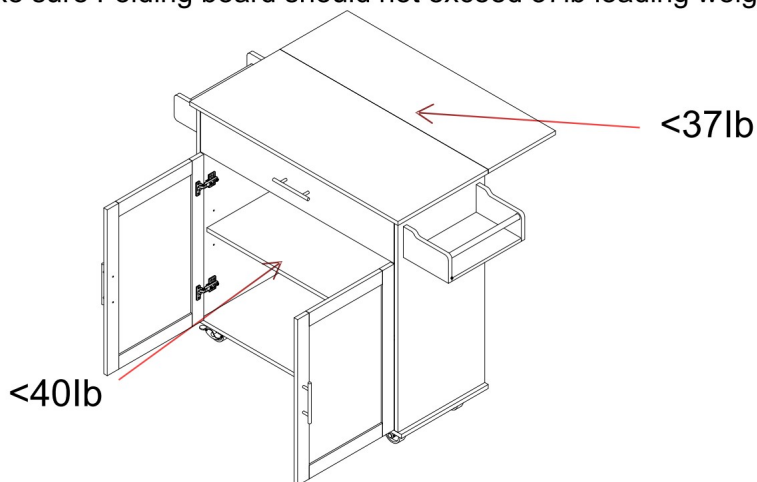

3. Make sure each drawer should not exceed 28lb loading weight.

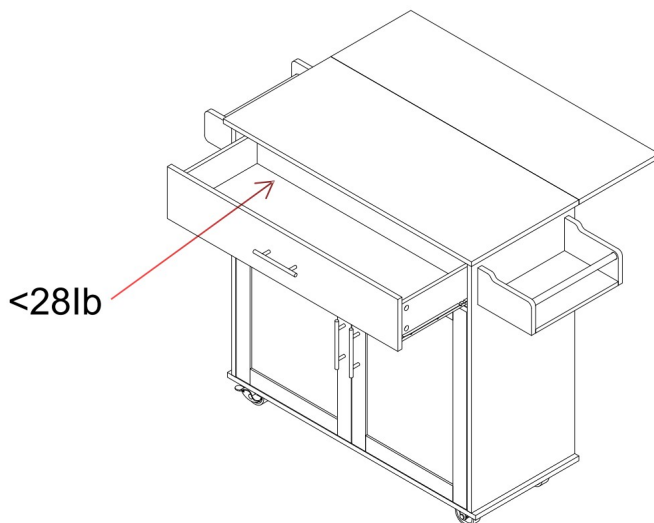

Cleaning

-For cleaning, wipe the surface with a damp (not wet) cloth or wipe dry with a clean lint free cotton cloth.

Fabricant : Shanghaimuxinmuyeyouxiangongsi

Adresse : Shuangchenglu 803nong11hao1602A-1609shi, baoshanqu,
Shanghai 200000 CN.

Importé en Australie : SIHAO PTY LTD. 1 ROKEVA STREETEASTWOOD
NSW 2122 Australie

Importé aux États-Unis : Sanven Technology Ltd. Suite 250, 9166 Anaheim
Place, Rancho Cucamonga, CA 91730



E-CrossStu GmbH
Mainzer Landstr.69, 60329 Francfort-sur-le-Main.



YH CONSULTING LIMITÉE.
A/S YH Consulting Limited Bureau 147, Centurion House,
London Road, Staines-upon-Thames, Surrey, TW18 4AX

VEVOR[®]

TOUGH TOOLS, HALF PRICE

Support and E-Warranty Certificate <https://www.vevor.com/support>

VEVOR[®]

TOUGH TOOLS, HALF PRICE

Technical Support and E-Warranty Certificate www.vevor.com/support

KITCHEN ISLAND USER MANUAL

MODEL:SR221264

We continue to be committed to provide you tools with competitive price.

"Save Half", "Half Price" or any other similar expressions used by us only represents an estimate of savings you might benefit from buying certain tools with us compared to the major top brands and but not necessarily mean to cover all categories of tools offered by us. You are kindly reminded to verify carefully when you are placing an order with us if you are actually saving half in comparison with the top major brands.

VEVOR®

TOUGH TOOLS, HALF PRICE

**KITCHEN ISLAND
(MODEL:SR221264)**

Thanks for purchasing one of our products, please read carefully the assembly instructions before the installation.

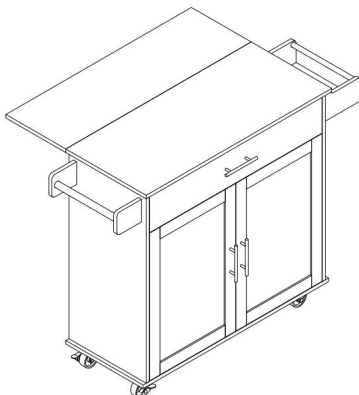

Model: SR221264

NEED HELP? CONTACT US!

Have product questions? Need technical support? Please feel free to contact us:

Technischer Support und E-Garantie-Zertifikat
www.vevor.com/support

This is the original instruction, please read all manual instructions carefully before operating. VEVOR reserves a clear interpretation of our user manual. The appearance of the product shall be subject to the product you received. Please forgive us that we won't inform you again if there are any technology or software updates on our product.

PRODUCT PARAMETERS

Model	ProductSize/mm (When the folding board is opened)	Loading Capacity	Top panel size(mm)
SR221264	1190x695x905	200 lb (Max)	900x390 900x290 (Folding board)

ASSEMBLY PRECAUTIONS

1. Assemble needs to follow these instructions. Incorrect assembly can be a hazard.
2. Wear safety goggles and heavy-duty work gloves during assembly.
3. Do not assemble when tired or under the influence of alcohol, drugs or medication.
4. Weight capacity and other product capabilities only apply to a wholly and correctly assembled product.
5. Keep the assembly area clean and well-lit.
6. Keep bystanders out of the area during assembly.
7. The weight of plate is heavy; pay attention to the installation to avoid hurting it, and if necessary, find someone to assist with the installation.

Der Zusammenbau dieses Wagens dauert etwa 2 Stunden.
Es wird empfohlen, dass ihn 2 Personen bedienen.

USE PRECAUTIONS





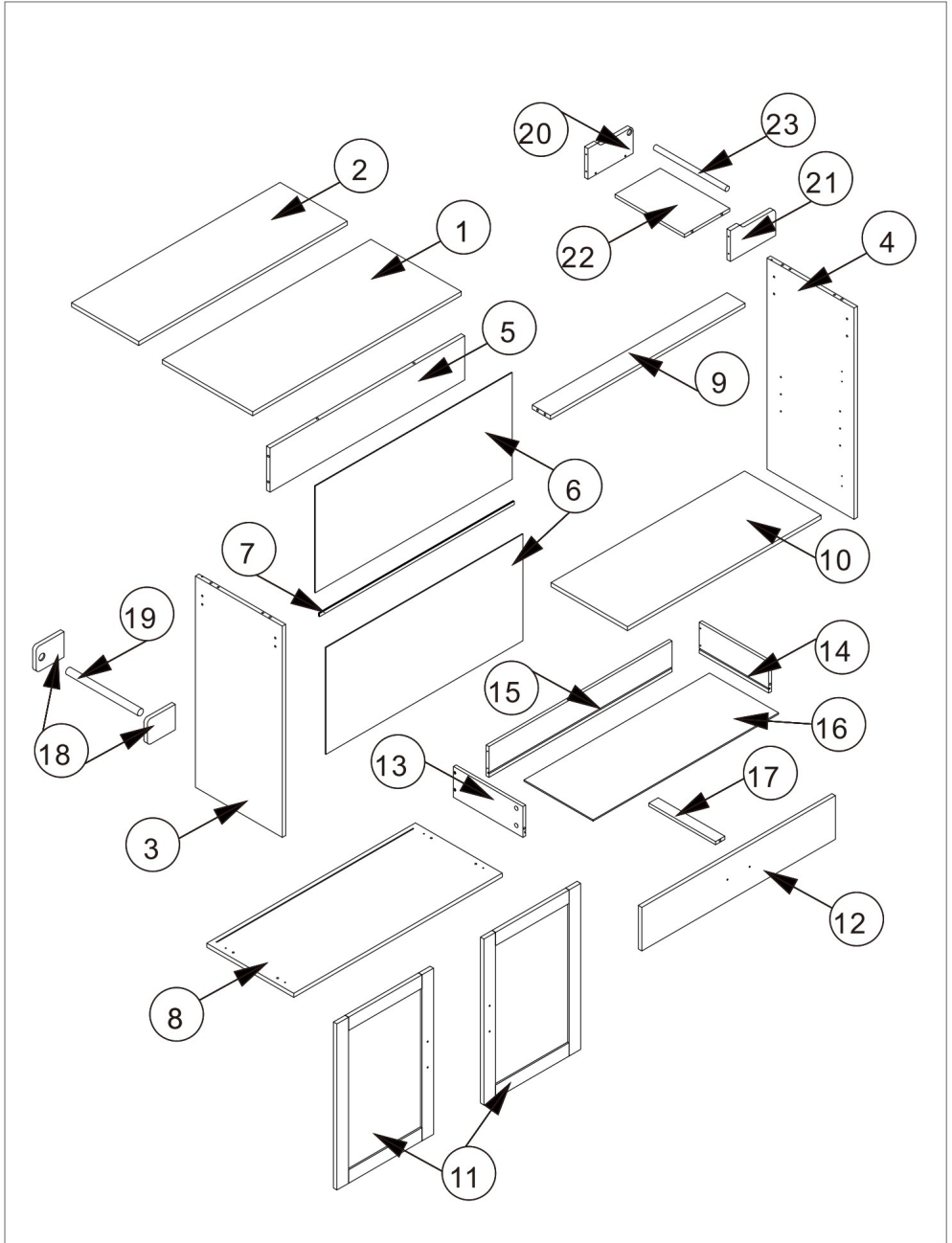

WARNING: TO PREVENT SERIOUS INJURY AND DEATH FROM TIPPING:

1. This product is not a toy. Do not allow children to play with or approach this item.
2. Use as intended only. Do not sit or stand on the product.
3. Inspect before every use. Do not use it if parts are loose or damaged.
4. Use on flat, level, and hard surfaces only.
5. Do not exceed the listed weight capacity. Tighten all knobs securely before applying load. Be aware of dynamic loading! The sudden load movement may briefly create an excess load, causing product failure.



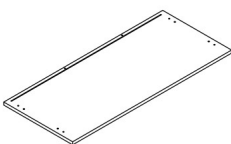
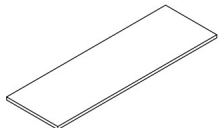
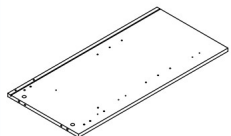
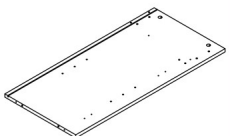
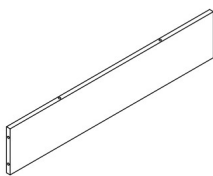
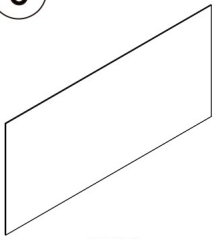

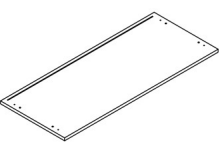
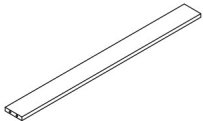
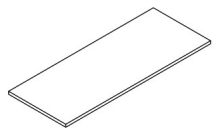
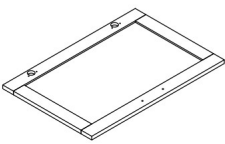
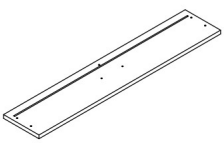

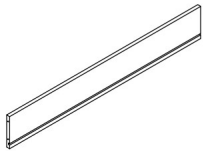
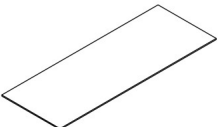

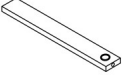
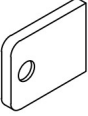
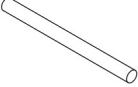
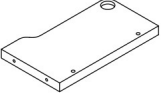
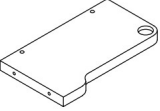
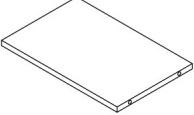
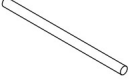











Exploded Drawing



PARTS LIST

<p>1</p>  <p>1 PC</p>	<p>2</p>  <p>1 PC</p>	<p>3</p>  <p>1 PC</p>	<p>4</p>  <p>1 PC</p>
<p>5</p>  <p>1 PC</p>	<p>6</p>  <p>2 PCS</p>	<p>7</p>  <p>1 PC</p>	<p>8</p>  <p>1 PC</p>
<p>9</p>  <p>1 PC</p>	<p>10</p>  <p>1 PC</p>	<p>11</p>  <p>2 PCS</p>	<p>12</p>  <p>1 PC</p>
<p>13</p>  <p>1 PC</p>	<p>14</p>  <p>1 PC</p>	<p>15</p>  <p>1 PC</p>	<p>16</p>  <p>1 PC</p>

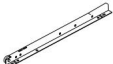
<p>17</p>  <p>1 PC</p>	<p>18</p>  <p>2 PCS</p>	<p>19</p>  <p>1 PC</p>	<p>20</p>  <p>1 PC</p>
<p>21</p>  <p>1 PC</p>	<p>22</p>  <p>1 PC</p>	<p>23</p>  <p>1 PC</p>	

A M6*35  23 PCS +1Ersatz	B Ø15*10  23 PCS +1Ersatz	C Ø6*30  8 PCS	D M4*35  4 PCS	E M4*20  6 PCS	F  3 PCS	G M3*12  8 PCS	H M7*40  8 PCS
I M5*14  26 PCS +1Ersatz	J  2 PCS	K  2 PCS	L M4*30  5 PCS	M M4*14  24 PCS +1Ersatz	N  4 PCS	O  4 PCS	P  2 PCS
Q  1 PC	CL  1 PC	CR  1 PC	DL  1 PC	DR  1 PC			

Cam Lock Fastening System

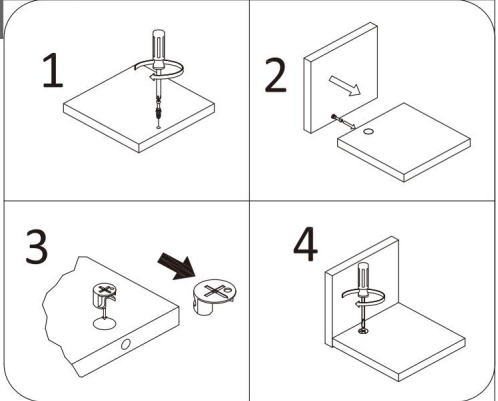
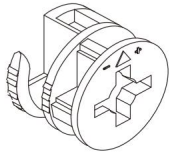

This Cam Lock Fastening System will be used throughout the assembly process

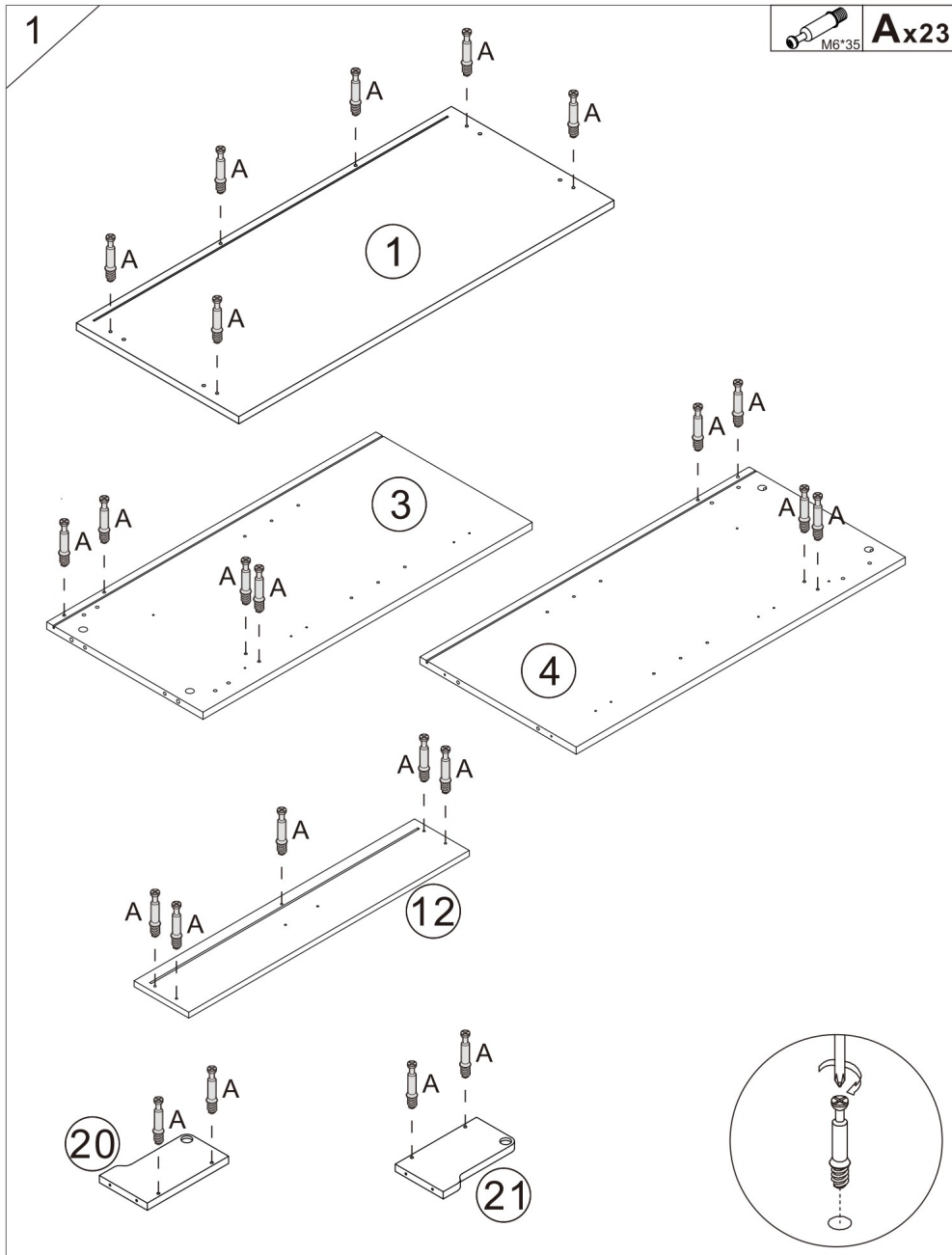

ASSEMBLY STEPS



2

	CLx1
	CRx1
 M3*12	Gx4

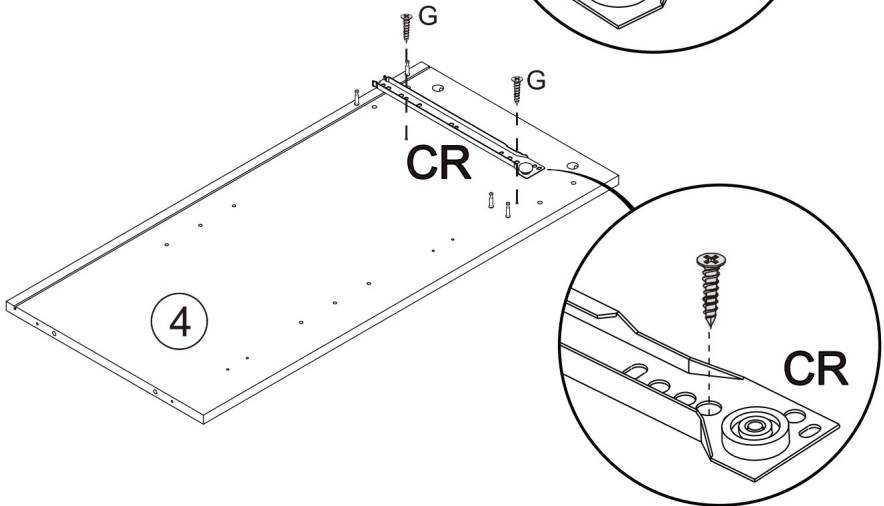
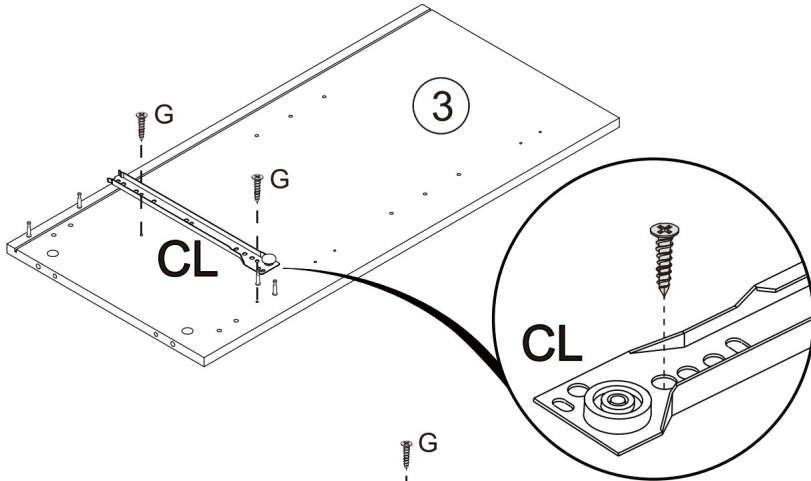

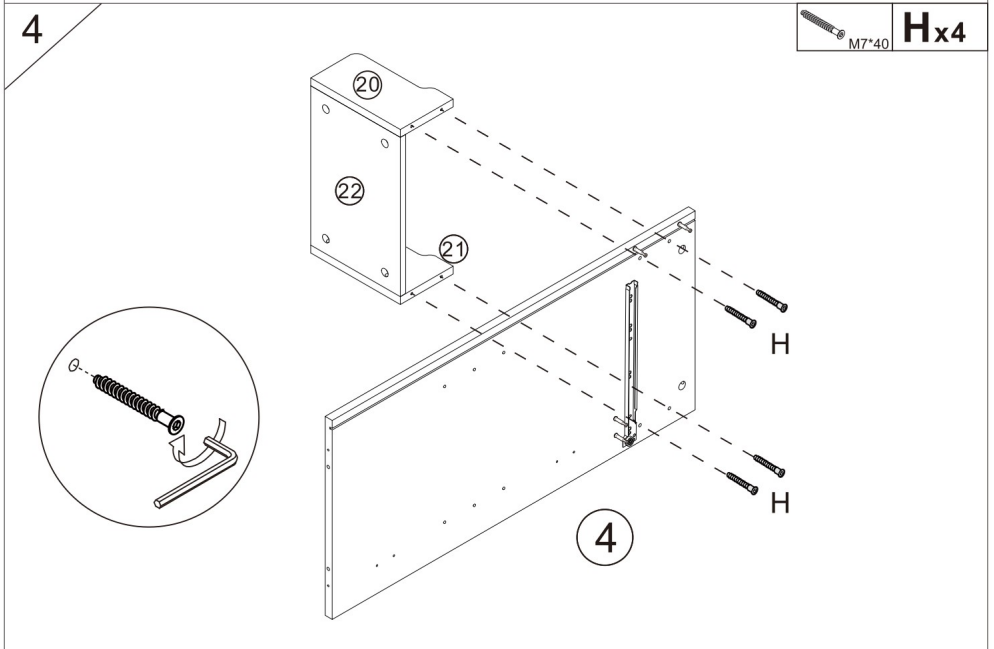
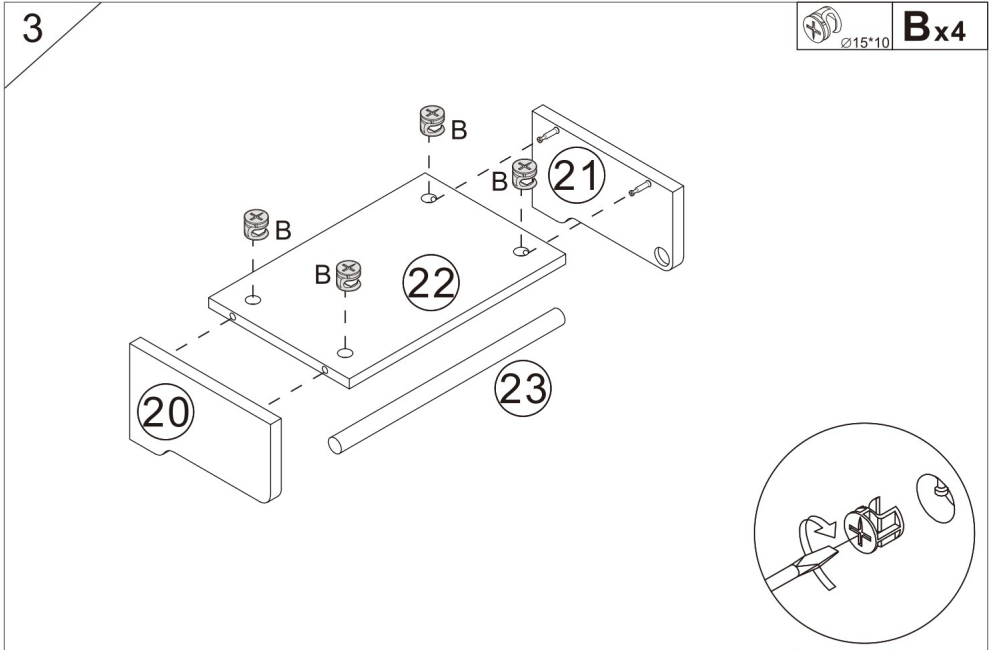

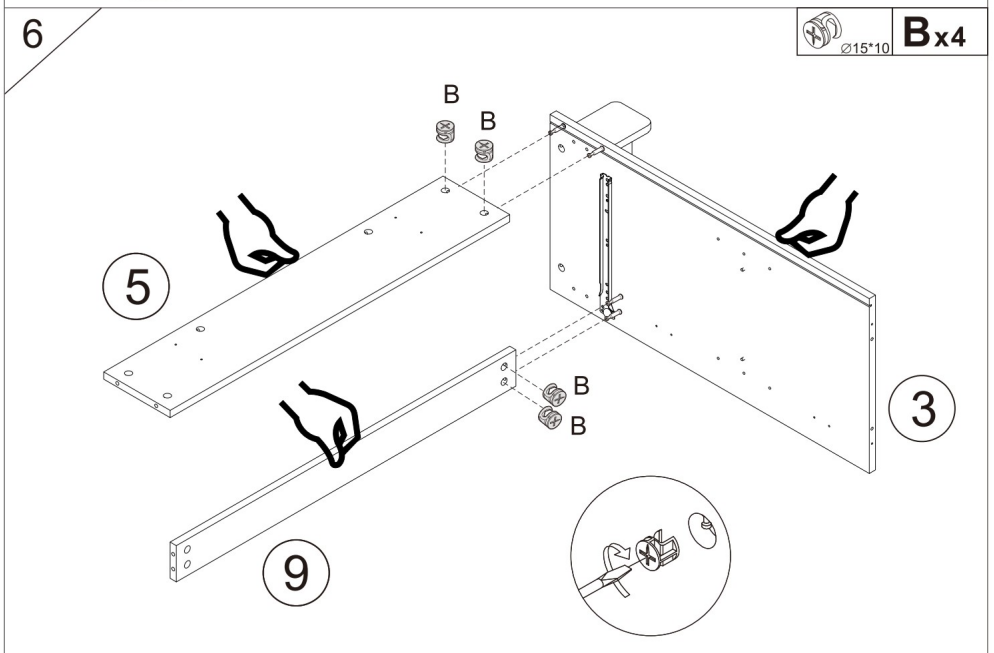
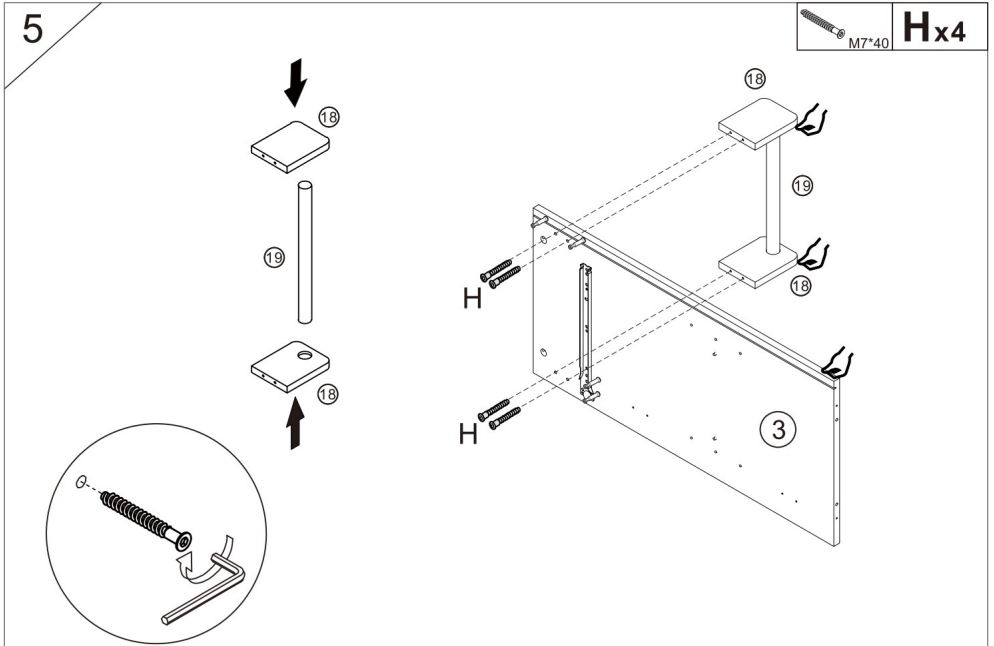

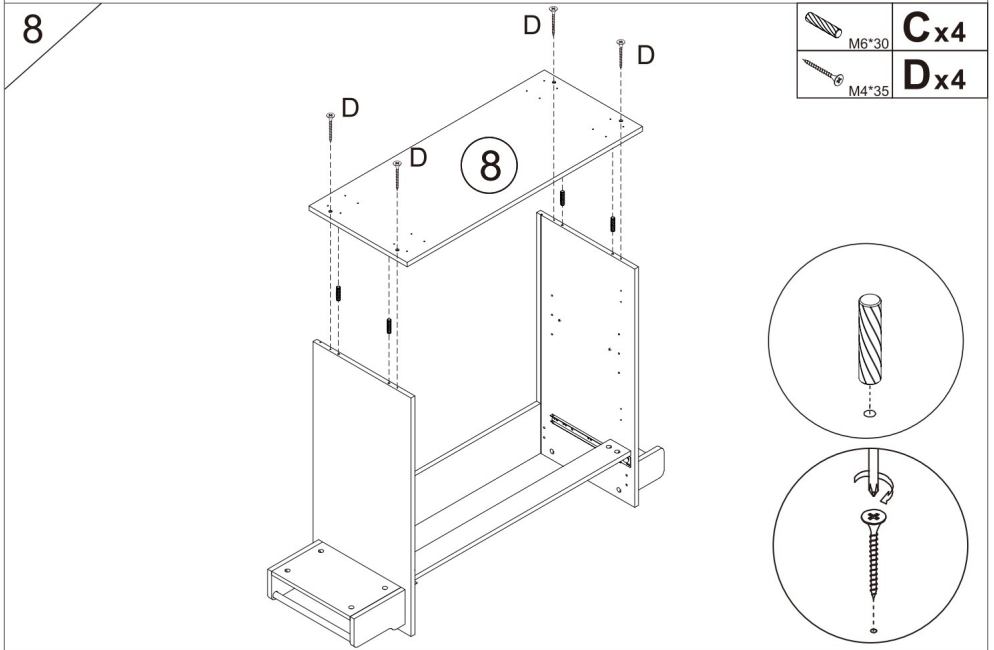
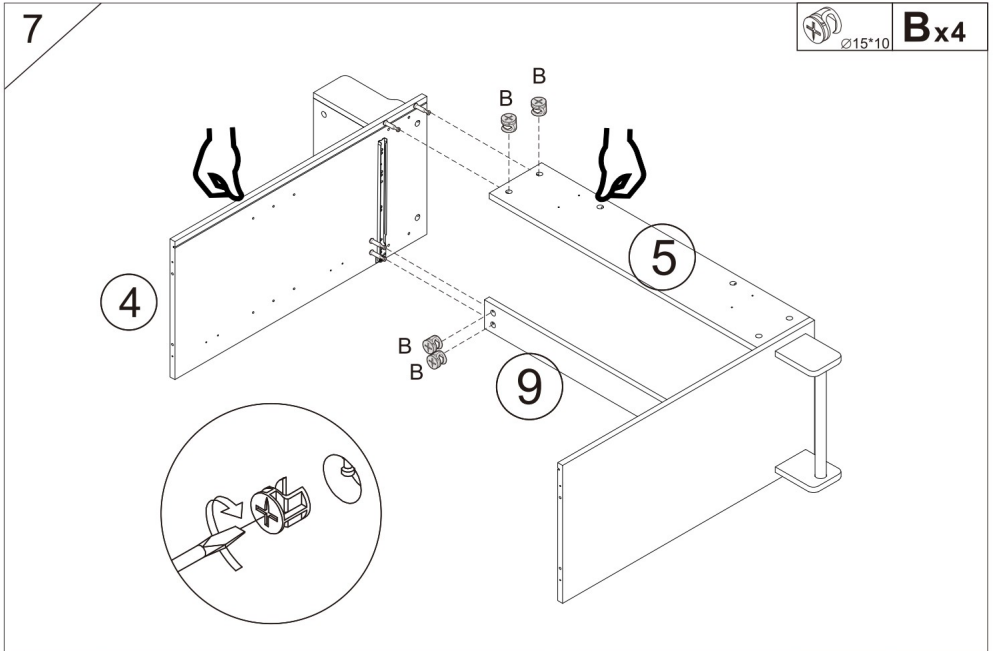

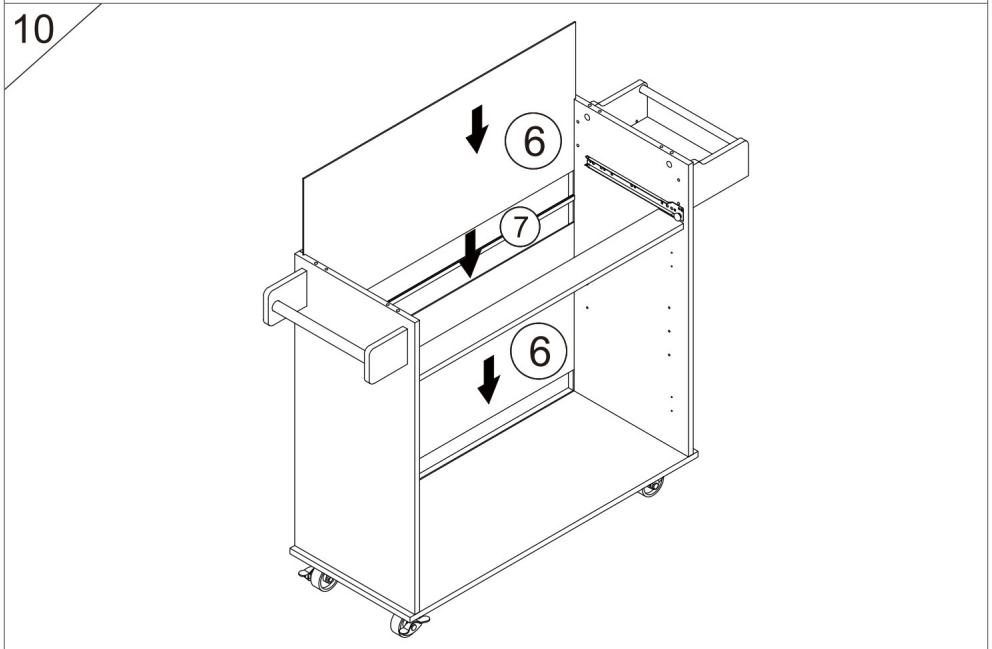
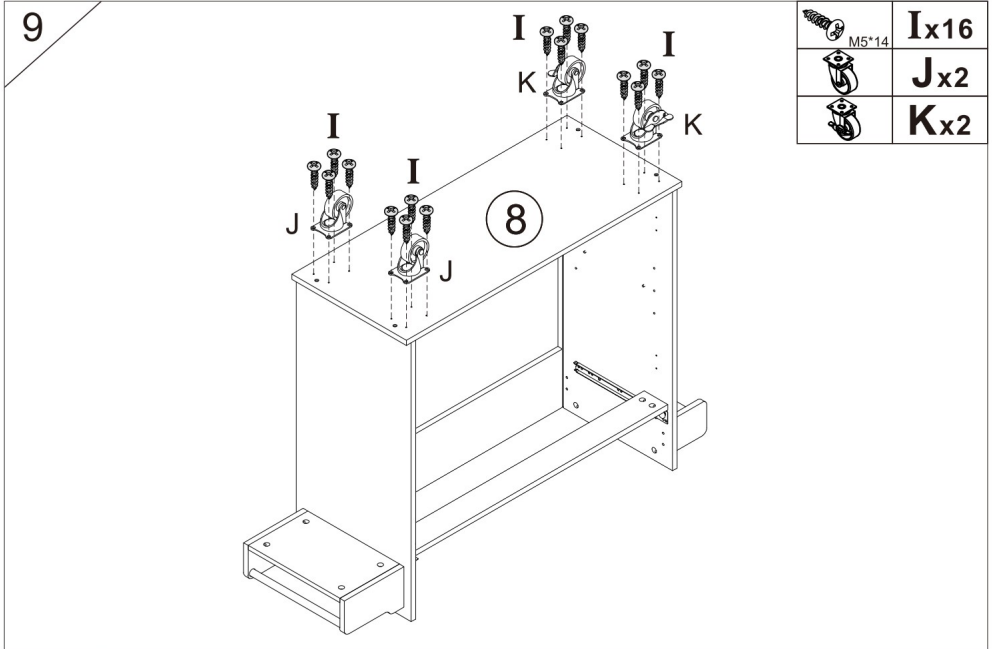

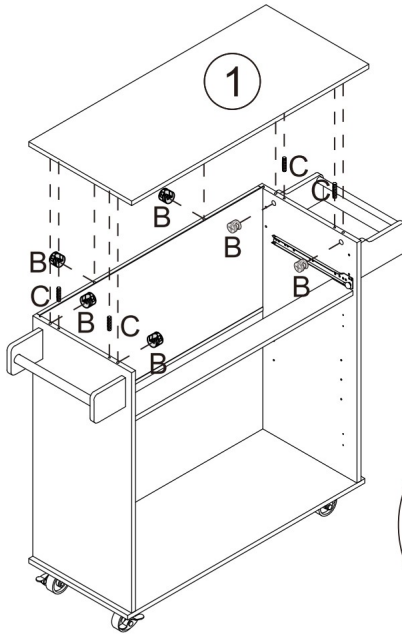

11



 Ø15*10	Bx6
 M6*30	Cx4

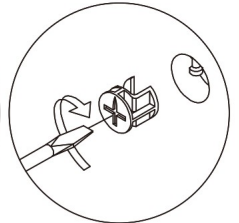
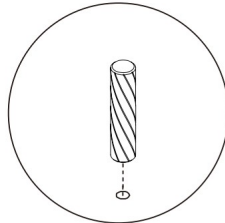

12

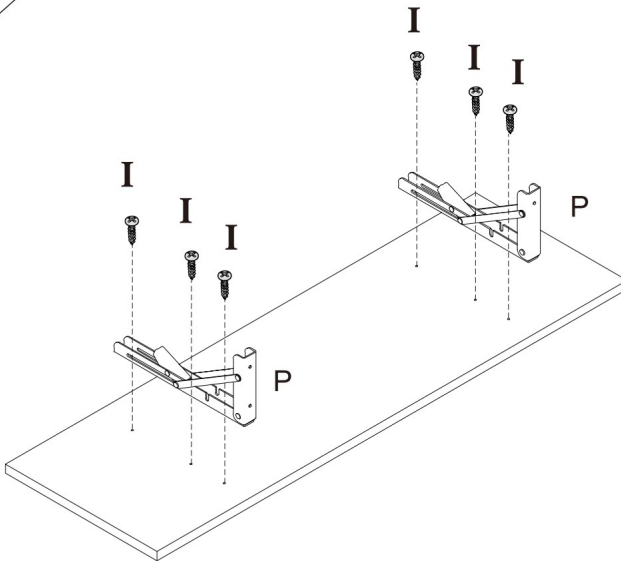

 M5*14	Ix6
	Px2

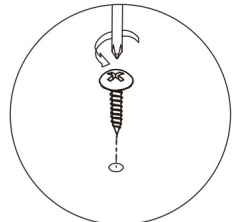
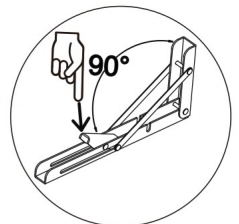

13

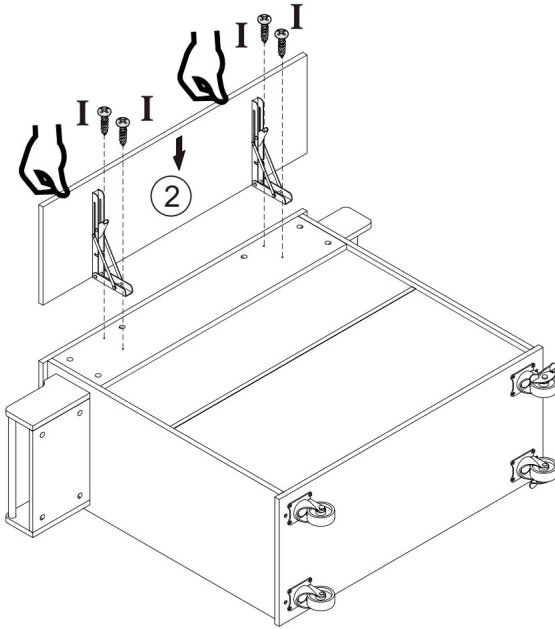

M5*14 **I**x4

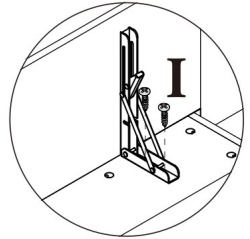
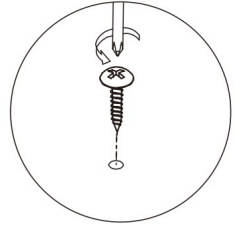

14

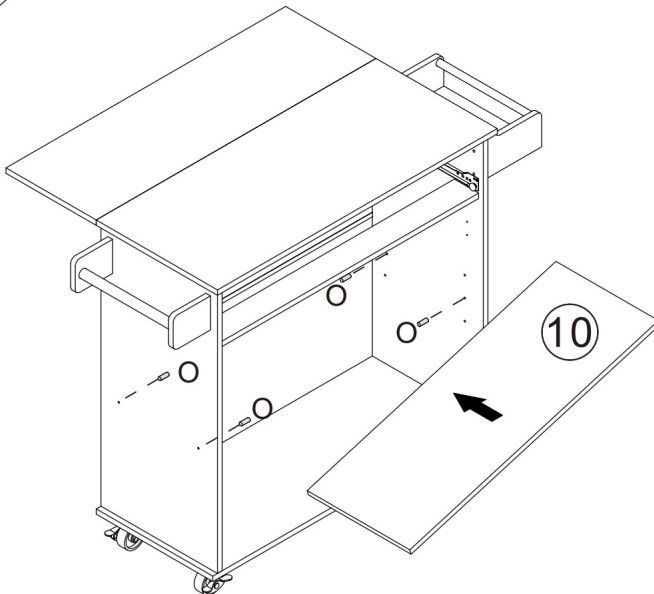

Ox4

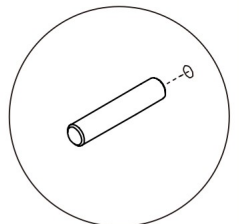



15

x2

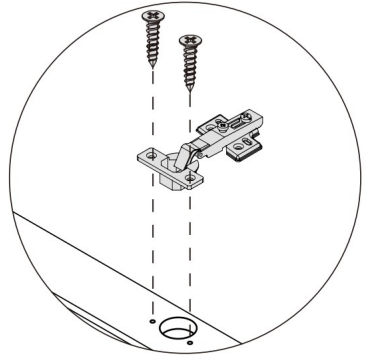
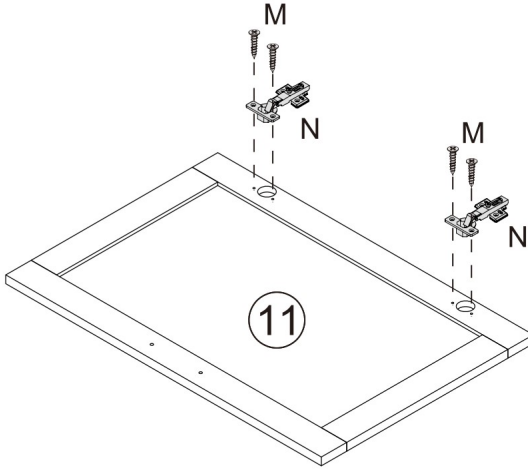
	M_{x8}
	N_{x4}



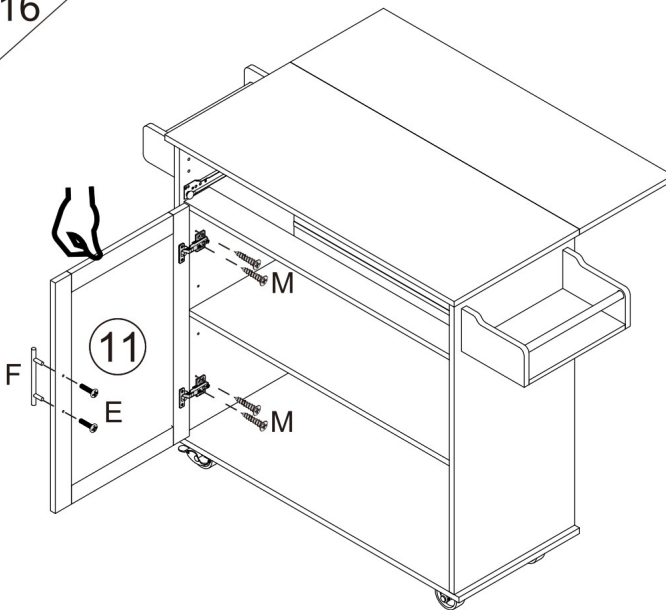

16

	E_{x2}
	F_{x1}
	M_{x4}



17

 M4*20	E x2
	F x1
 M4*14	M x4

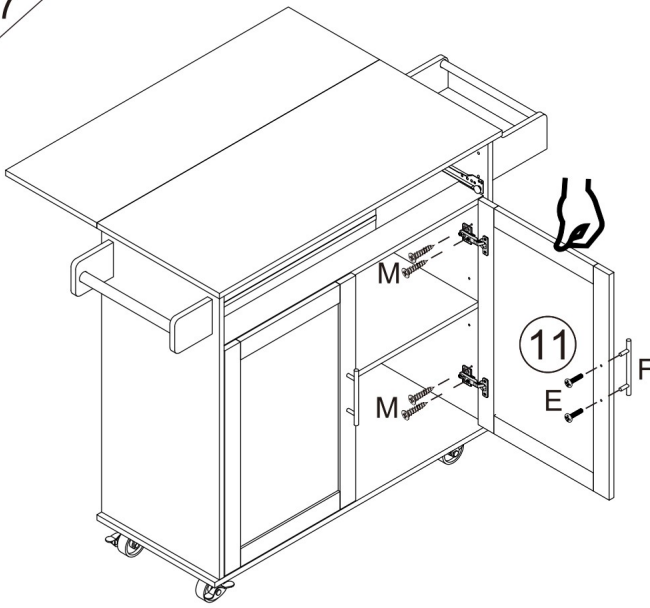

18

 M4*14	M x8
---	-------------

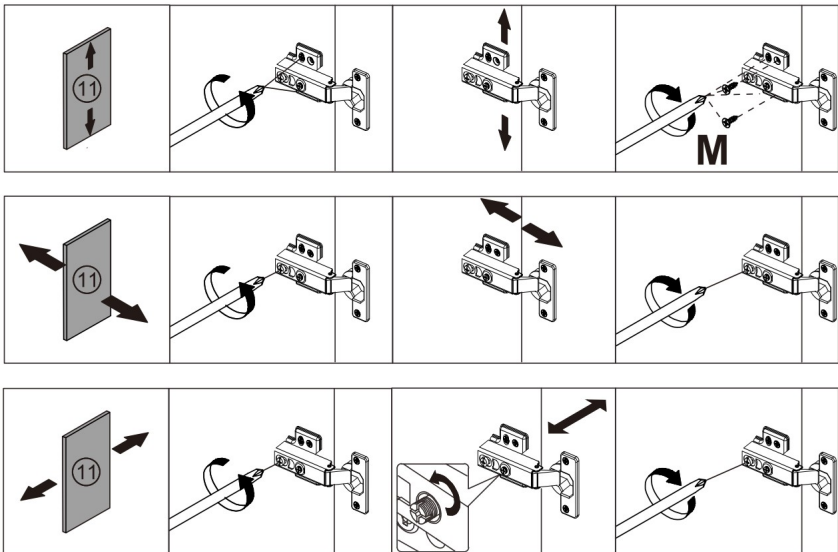





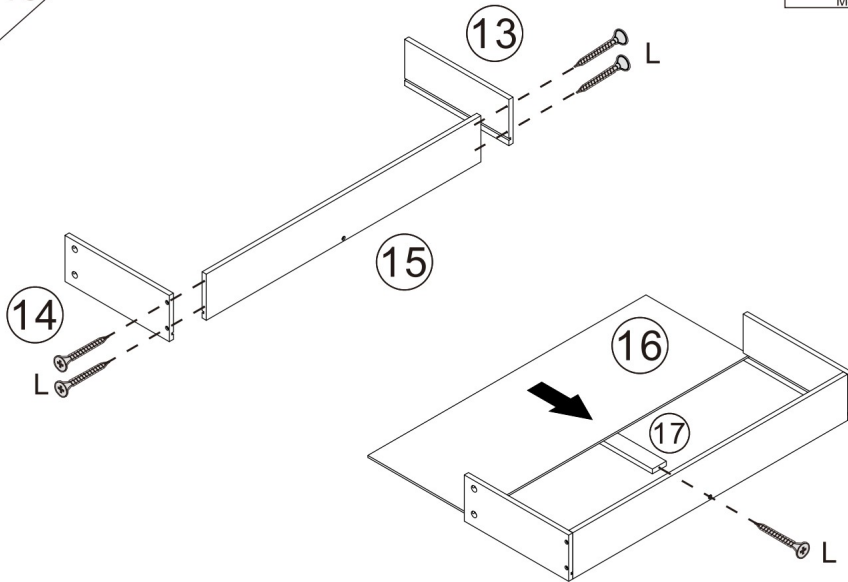

19

M4*30 **Lx5**



20

 $\varnothing 15 \times 10$	Bx5
 M4*20	Ex2
	Fx1
	DLx1
	DRx1
 M3*12	Gx4

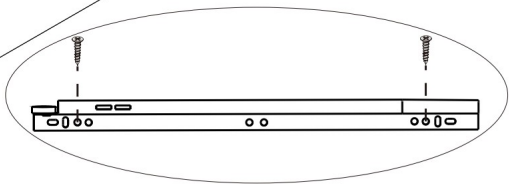
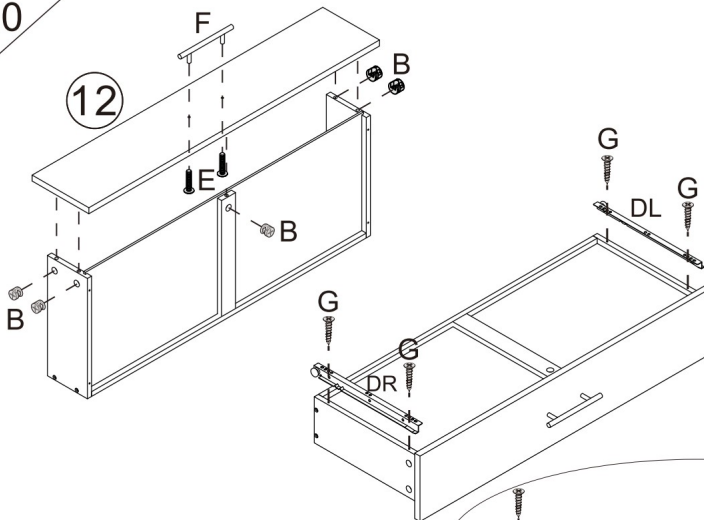

21

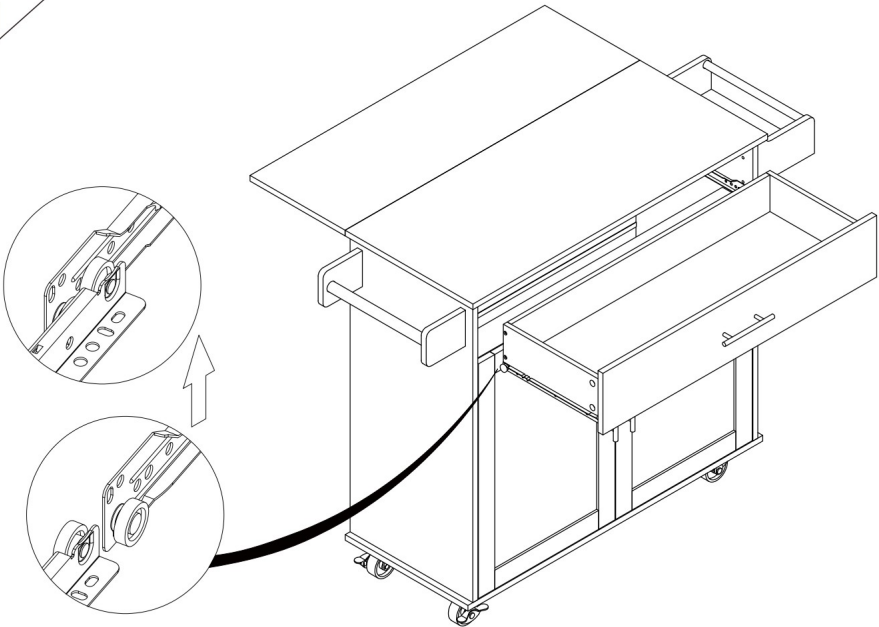

22

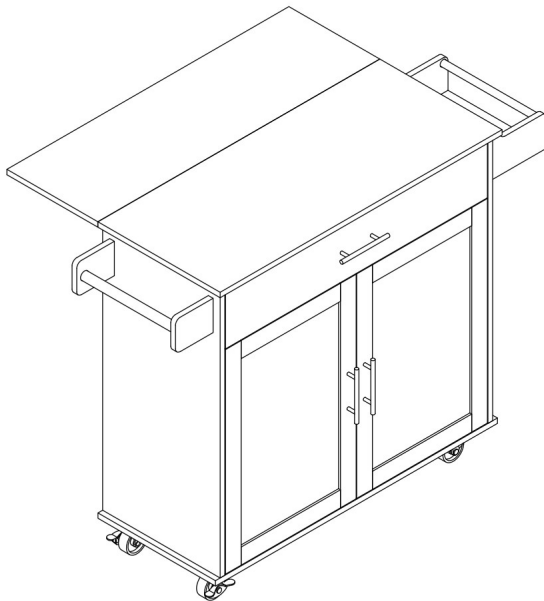

General Care

1. Make sure each layer should not exceed 40lb loading weight.
2. Make sure Folding board should not exceed 37lb loading weight.

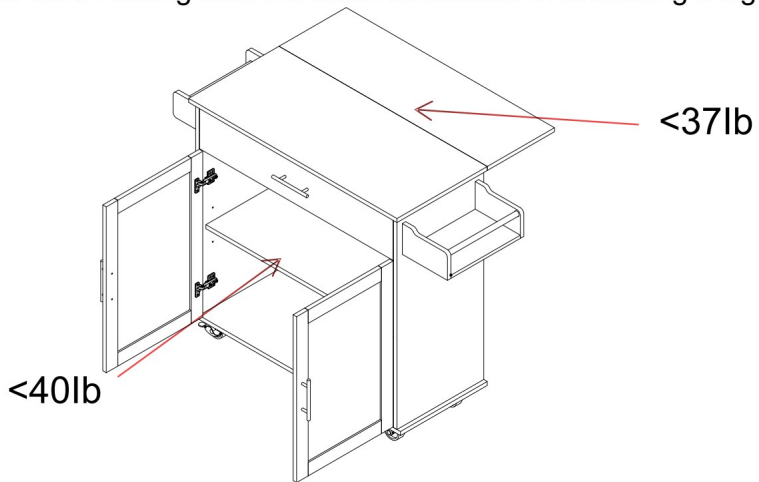

3. Make sure each drawer should not exceed 28lb loading weight.

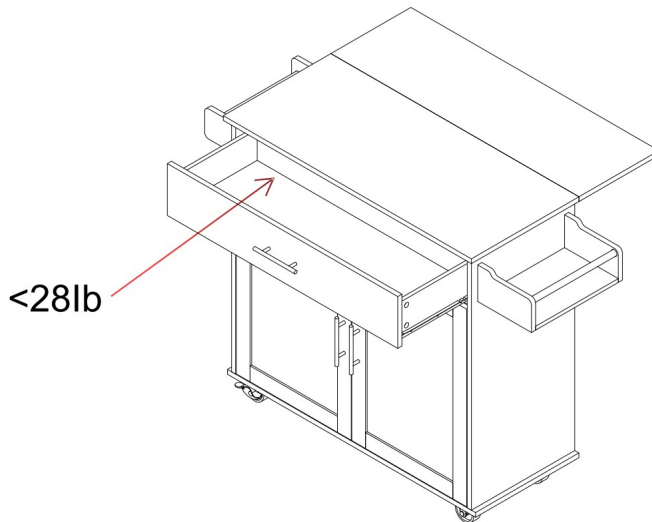

Cleaning

-For cleaning, wipe the surface with a damp (not wet) cloth or wipe dry with a clean lint free cotton cloth.

Hersteller: Shanghai muxinmuyeyouxiangongsi

Adresse: Shuangchenglu 803nong11hao1602A-1609shi, baoshanqu, Shanghai 200000 CN.

Nach AUS importiert: SIHAO PTY LTD. 1 ROKEVA STREET EASTWOOD NSW 2122 Australien

Importiert in die USA: Sanven Technology Ltd. Suite 250, 9166 Anaheim Place, Rancho Cucamonga, CA 91730



E-CrossStu GmbH
Mainzer Landstr.69, 60329 Frankfurt am Main.



YH CONSULTING LIMITED.
C/O YH Consulting Limited Office 147, Centurion House,
London Road, Staines-upon-Thames, Surrey, TW18 4AX

VEVOR[®]

TOUGH TOOLS, HALF PRICE

Support and E-Warranty Certificate <https://www.vevor.com/support>

VEVOR[®]

TOUGH TOOLS, HALF PRICE

Technical Support and E-Warranty Certificate www.vevor.com/support

KITCHEN ISLAND USER MANUAL

MODEL:SR221264

We continue to be committed to provide you tools with competitive price.

"Save Half", "Half Price" or any other similar expressions used by us only represents an estimate of savings you might benefit from buying certain tools with us compared to the major top brands and do not necessarily mean to cover all categories of tools offered by us. You are kindly reminded to verify carefully when you are placing an order with us if you are actually saving half in comparison with the top major brands.

VEVOR®

TOUGH TOOLS, HALF PRICE

**KITCHEN ISLAND
(MODEL:SR221264)**

Thanks for purchasing one of our products, please read carefully the assembly instructions before the installation.

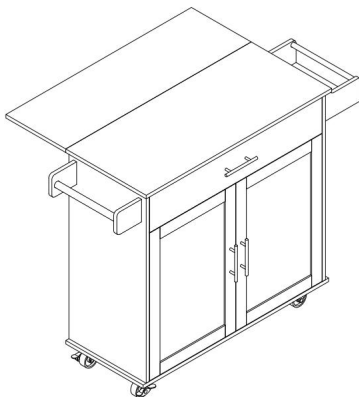

Model: SR221264

NEED HELP? CONTACT US!

Have product questions? Need technical support? Please feel free to contact us:

**Supporto tecnico e certificato di garanzia
elettronica www.vevor.com/support**

This is the original instruction, please read all manual instructions carefully before operating. VEVOR reserves a clear interpretation of our user manual. The appearance of the product shall be subject to the product you received. Please forgive us that we won't inform you again if there are any technology or software updates on our product.

PRODUCT PARAMETERS

Model	ProductSize/mm (When the folding board is opened)	Loading Capacity	Top panel size(mm)
SR221264	1190x695x905	200 lb (Max)	900x390 900x290 (Folding board)

ASSEMBLY PRECAUTIONS

1. Assemble needs to follow these instructions. Incorrect assembly can be a hazard.
2. Wear safety goggles and heavy-duty work gloves during assembly.
3. Do not assemble when tired or under the influence of alcohol, drugs or medication.
4. Weight capacity and other product capabilities only apply to a wholly and correctly assembled product.
5. Keep the assembly area clean and well-lit.
6. Keep bystanders out of the area during assembly.
7. The weight of plate is heavy; pay attention to the installation to avoid hurting it, and if necessary, find someone to assist with the installation.

Il montaggio di questo carrello richiederà circa 2 ore; si consiglia di farlo utilizzare da due persone.

USE PRECAUTIONS





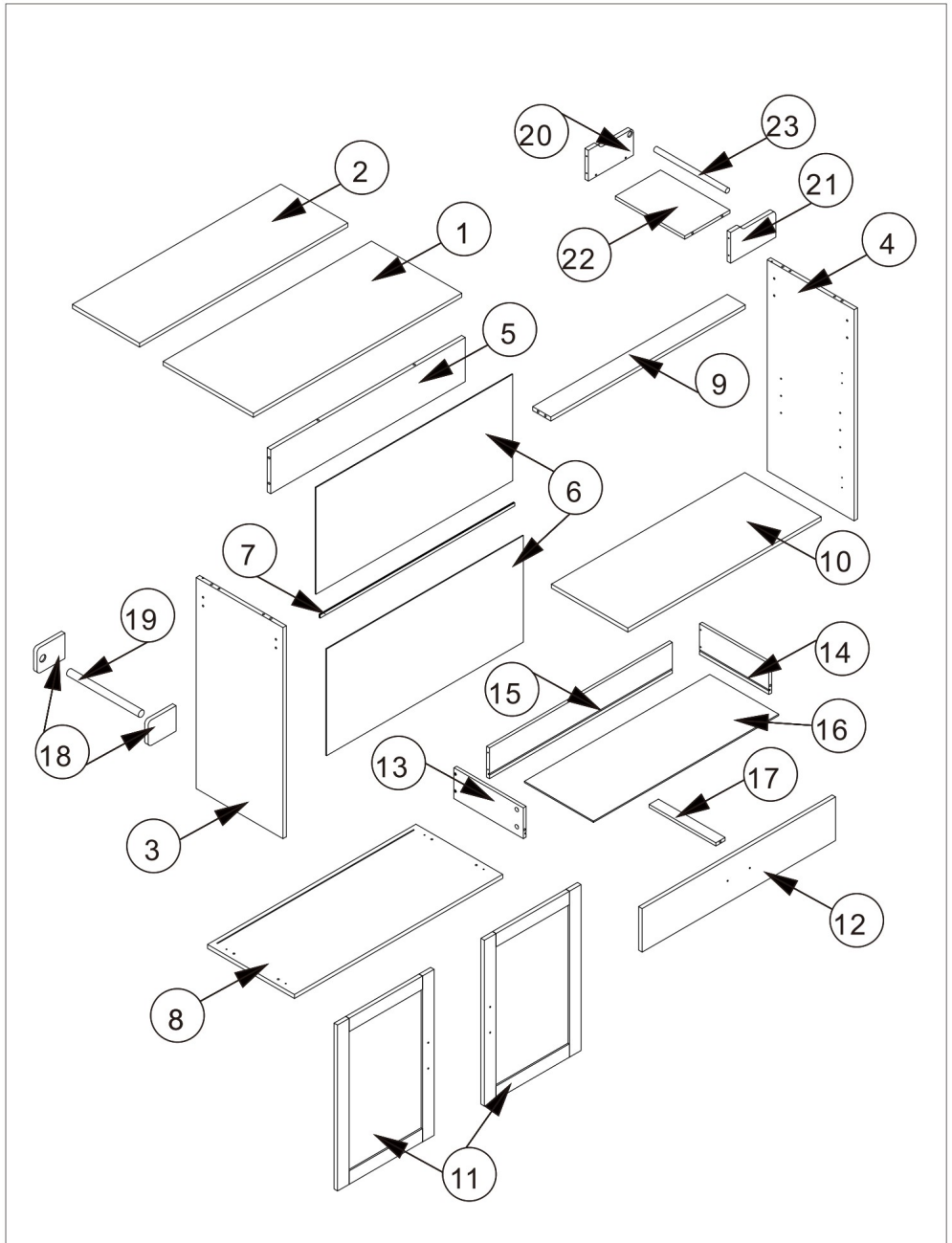

WARNING: TO PREVENT SERIOUS INJURY AND DEATH FROM TIPPING:

1. This product is not a toy. Do not allow children to play with or approach this item.
2. Use as intended only. Do not sit or stand on the product.
3. Inspect before every use. Do not use it if parts are loose or damaged.
4. Use on flat, level, and hard surfaces only.
5. Do not exceed the listed weight capacity. Tighten all knobs securely before applying load. Be aware of dynamic loading! The sudden load movement may briefly create an excess load, causing product failure.



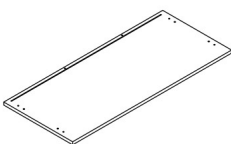
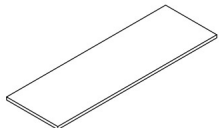
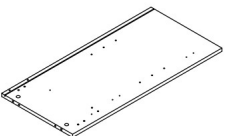
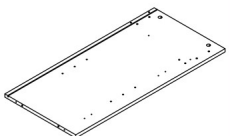
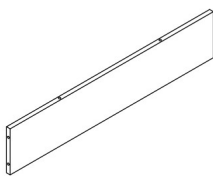
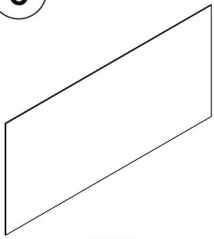

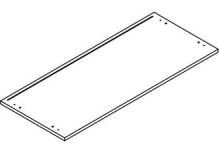
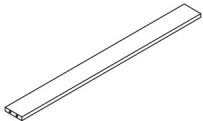
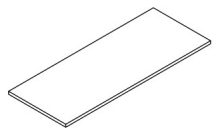
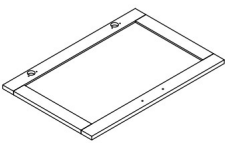
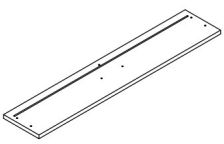

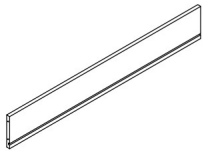
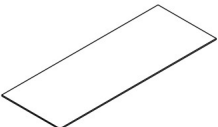

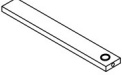
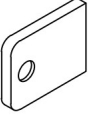
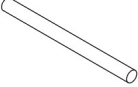
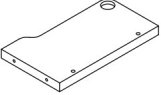
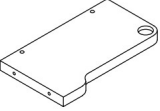
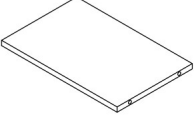
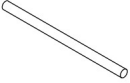











Exploded Drawing



PARTS LIST

<p>1</p>  <p>1 PC</p>	<p>2</p>  <p>1 PC</p>	<p>3</p>  <p>1 PC</p>	<p>4</p>  <p>1 PC</p>
<p>5</p>  <p>1 PC</p>	<p>6</p>  <p>2 PCS</p>	<p>7</p>  <p>1 PC</p>	<p>8</p>  <p>1 PC</p>
<p>9</p>  <p>1 PC</p>	<p>10</p>  <p>1 PC</p>	<p>11</p>  <p>2 PCS</p>	<p>12</p>  <p>1 PC</p>
<p>13</p>  <p>1 PC</p>	<p>14</p>  <p>1 PC</p>	<p>15</p>  <p>1 PC</p>	<p>16</p>  <p>1 PC</p>

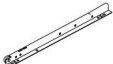
<p>17</p>  <p>1 PC</p>	<p>18</p>  <p>2 PCS</p>	<p>19</p>  <p>1 PC</p>	<p>20</p>  <p>1 PC</p>
<p>21</p>  <p>1 PC</p>	<p>22</p>  <p>1 PC</p>	<p>23</p>  <p>1 PC</p>	

A M6*35  23 PCS +1spare	B Ø15*10  23 PCS +1spare	C Ø6*30  8 PCS	D M4*35  4 PCS	E M4*20  6 PCS	F  3 PCS	G M3*12  8 PCS	H M7*40  8 PCS
I M5*14  26 PCS +1spare	J  2 PCS	K  2 PCS	L M4*30  5 PCS	M M4*14  24 PCS +1spare	N  4 PCS	O  4 PCS	P  2 PCS
Q  1 PC	CL  1 PC	CR  1 PC	DL  1 PC	DR  1 PC			

Cam Lock Fastening System

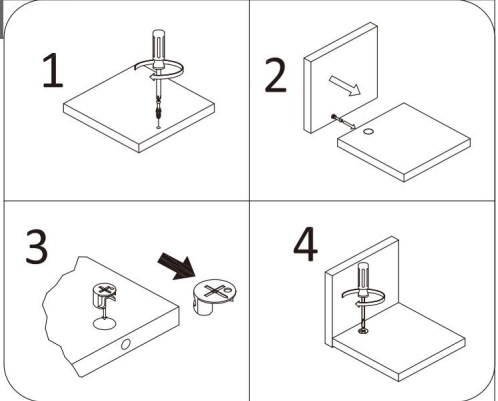
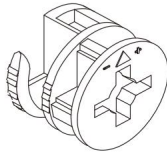

This Cam Lock Fastening System will be used throughout the assembly process

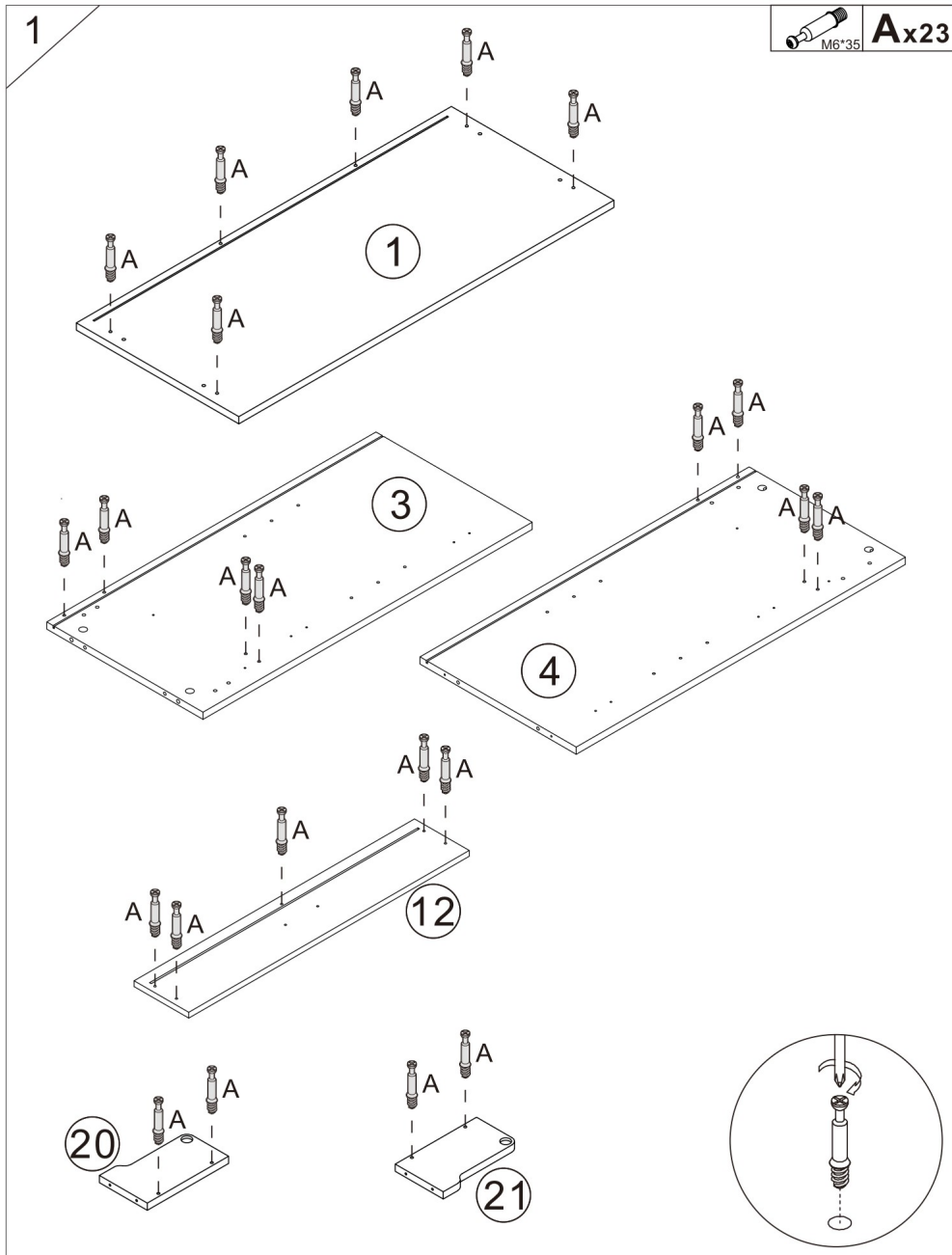

ASSEMBLY STEPS



2

	CLx1
	CRx1
 M3*12	Gx4

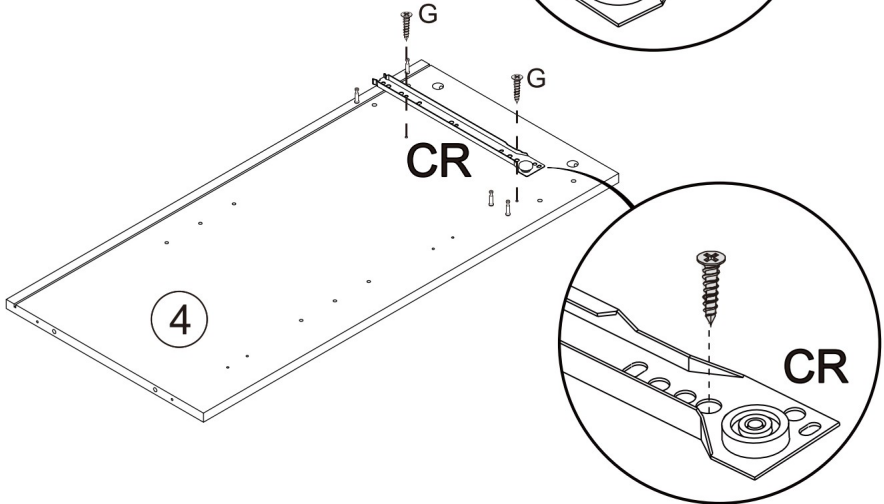
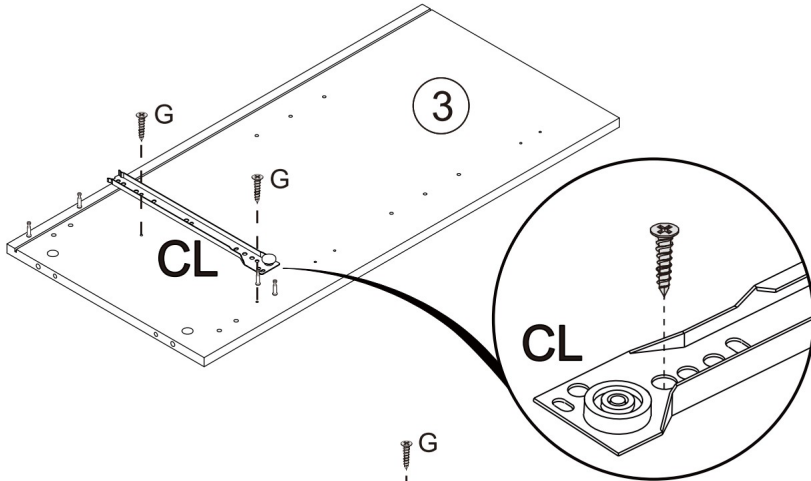

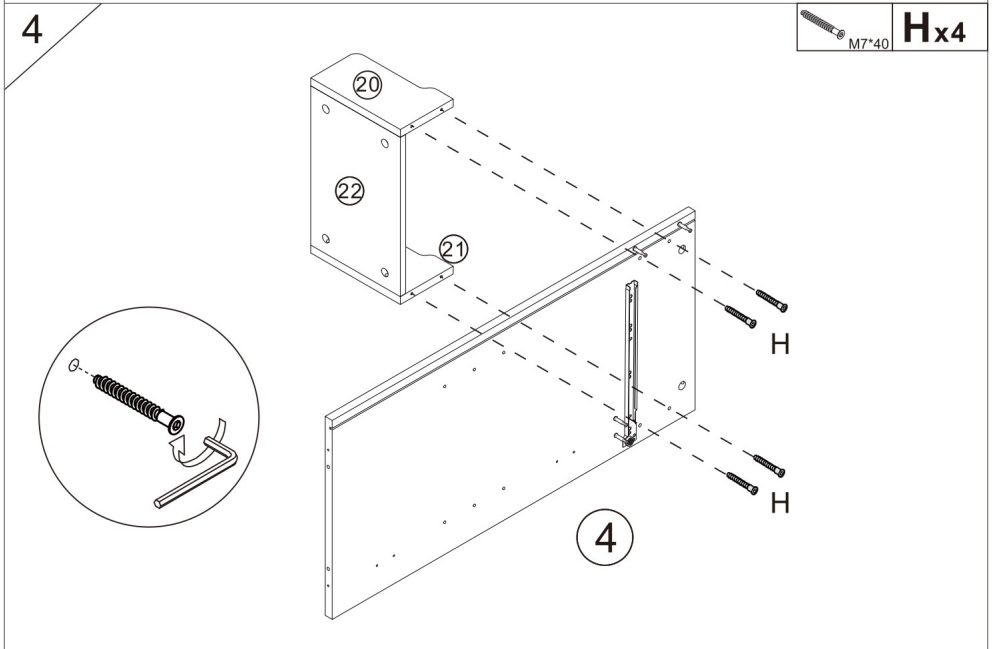
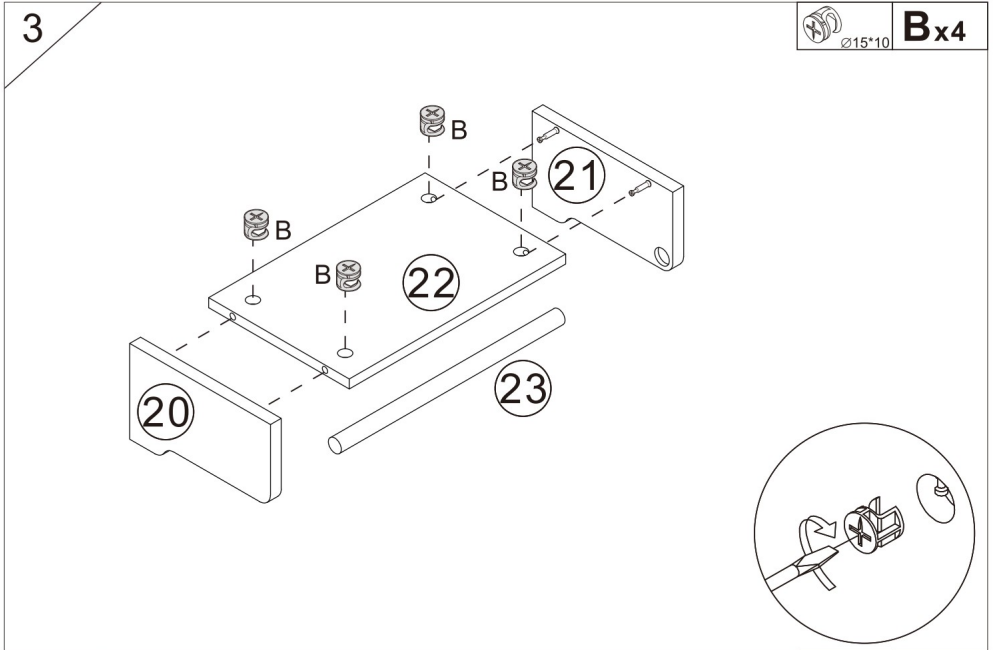

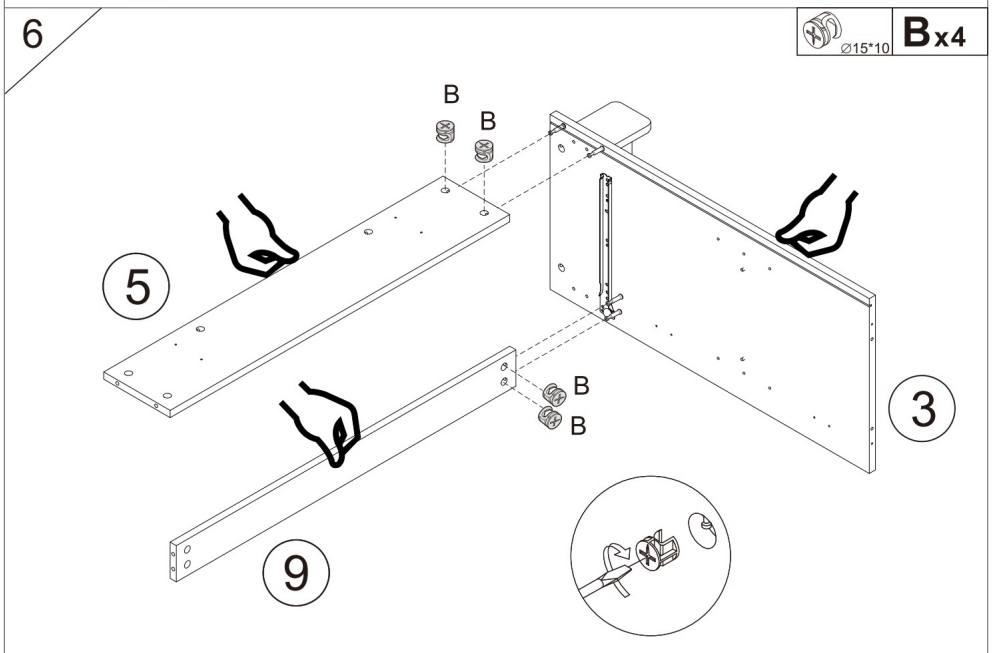
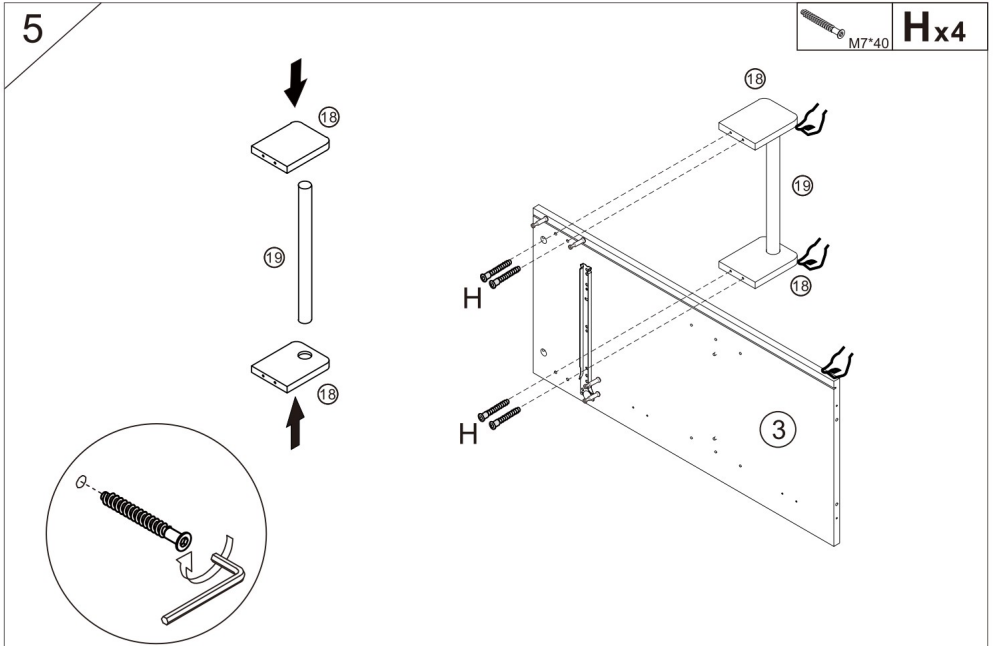

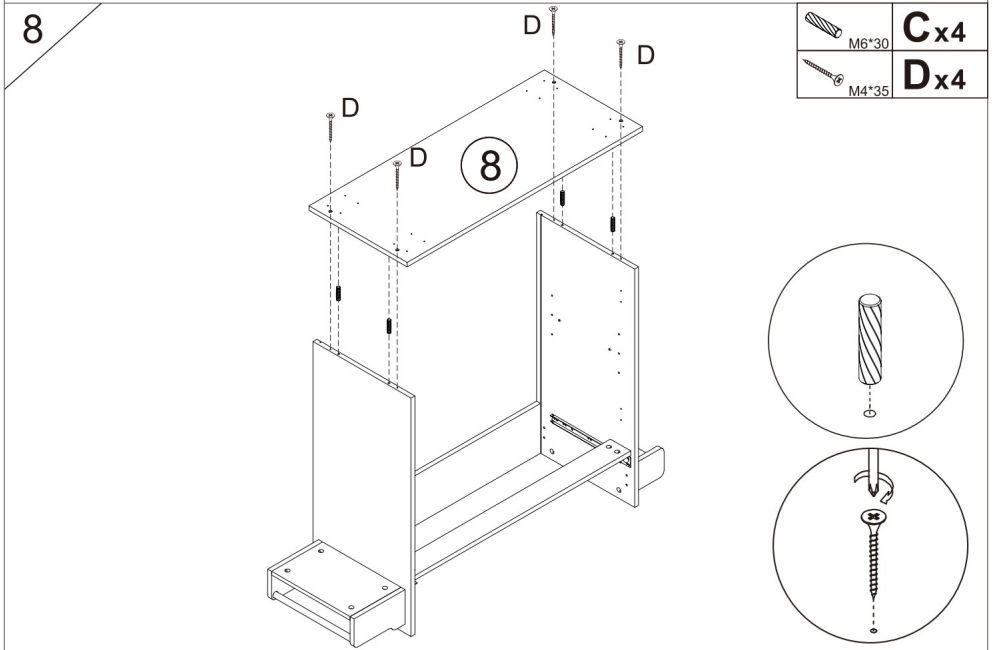
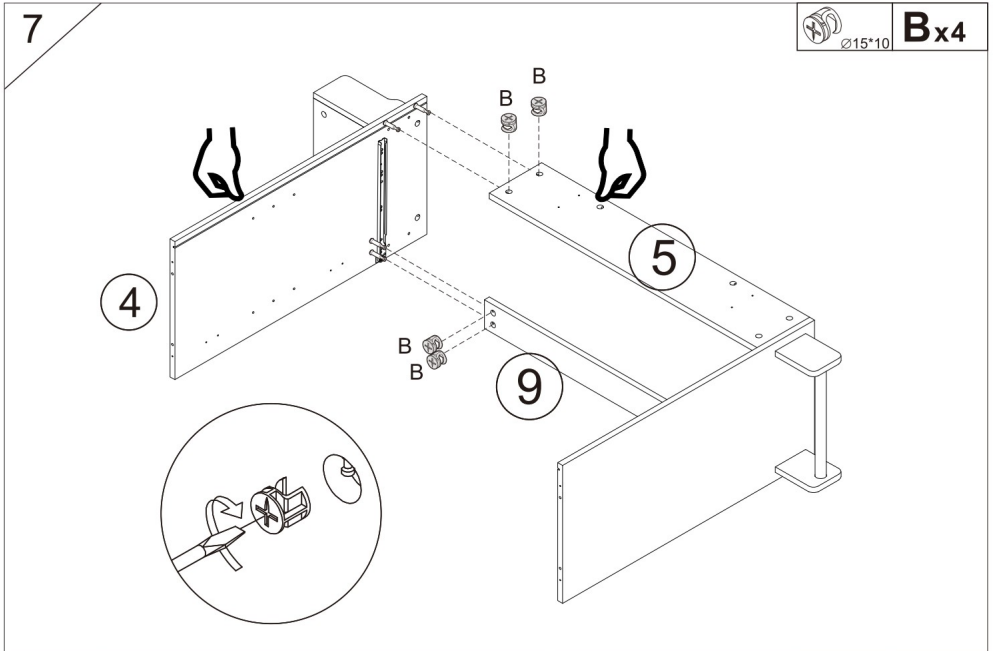

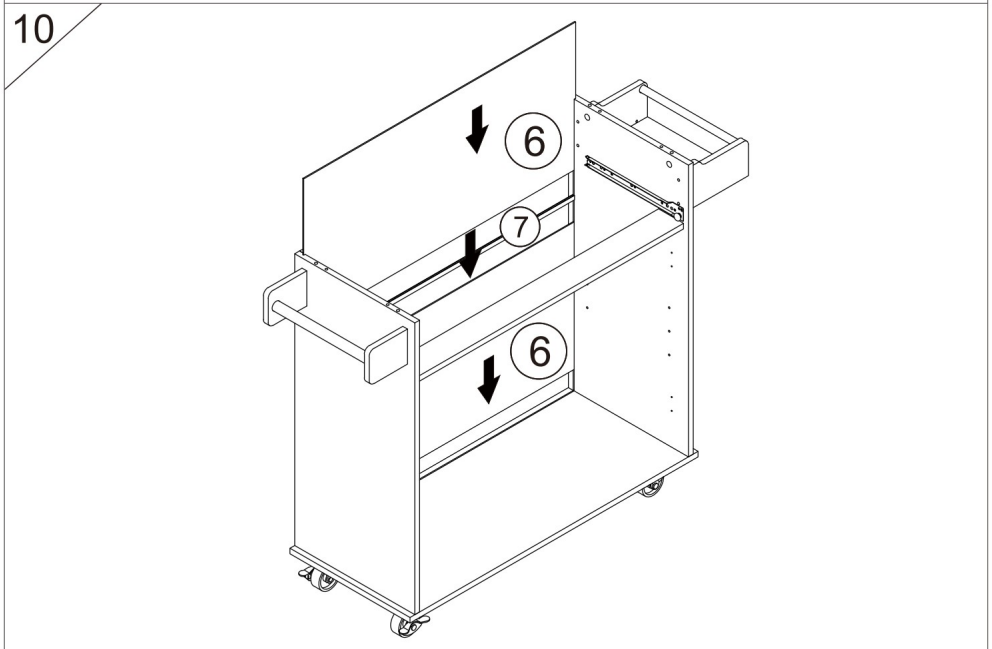
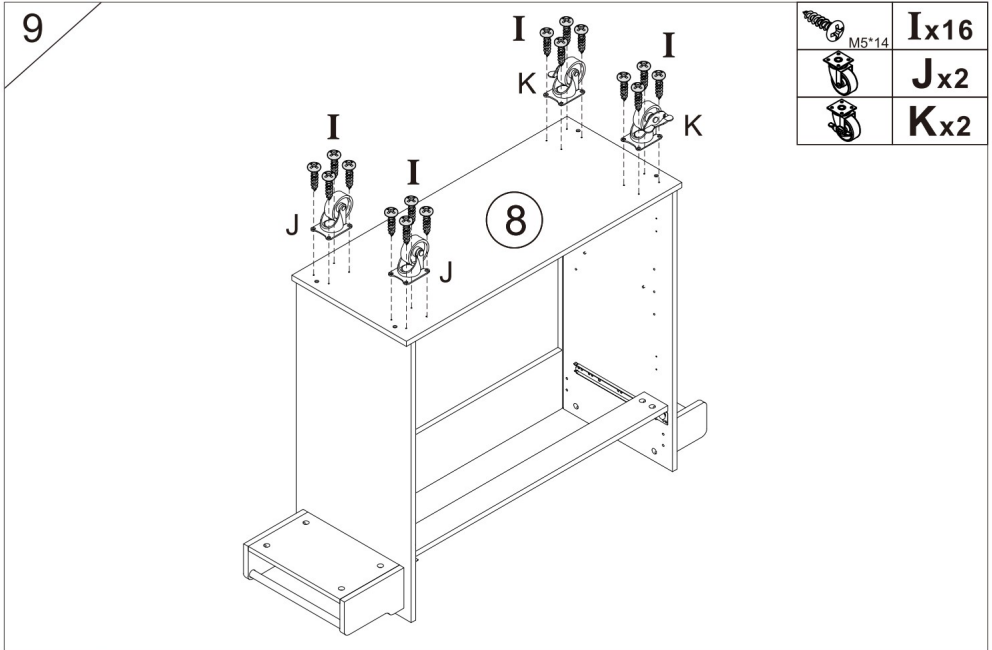

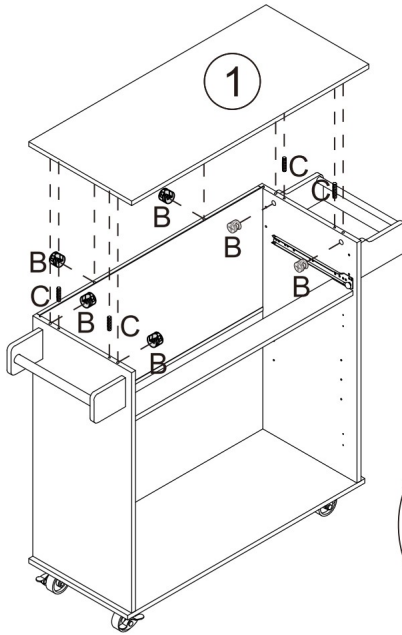

11



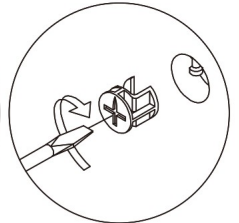
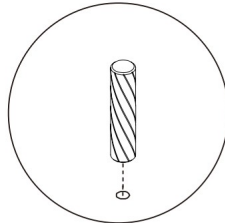

 Ø15*10	Bx6
 M6*30	Cx4

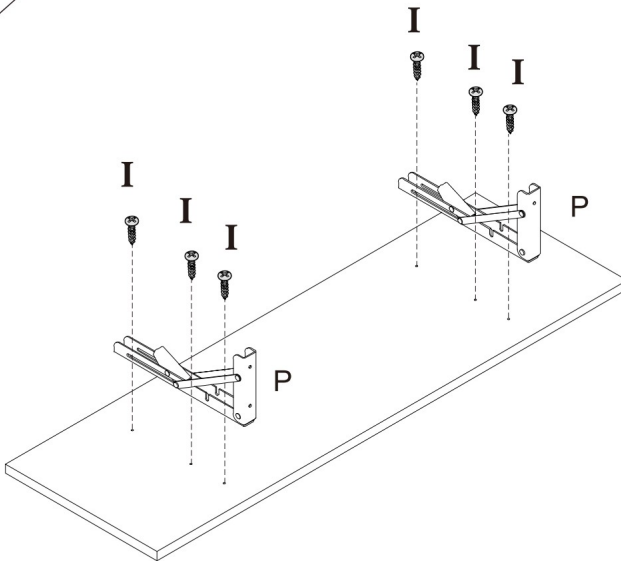

12



 M5*14	Ix6
	Px2

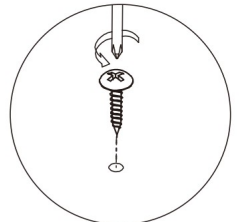
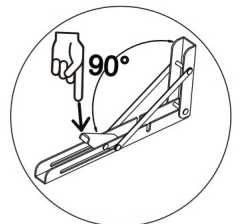

13

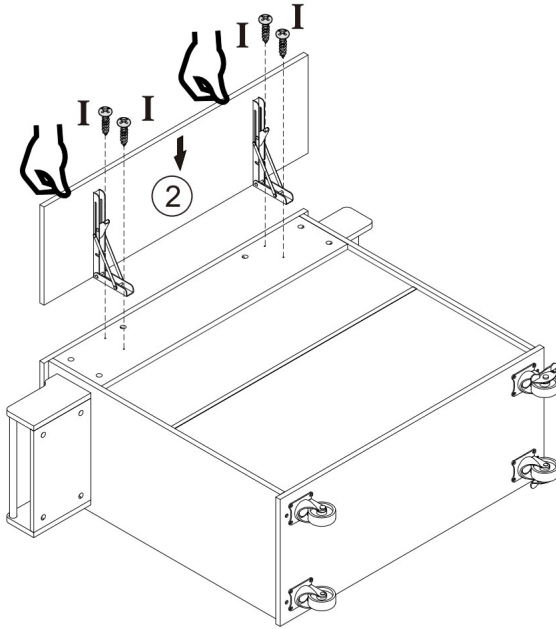

M5*14 **I**x4

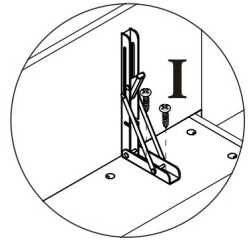
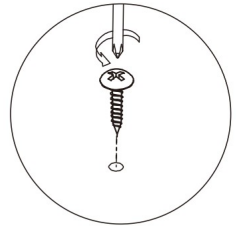

14

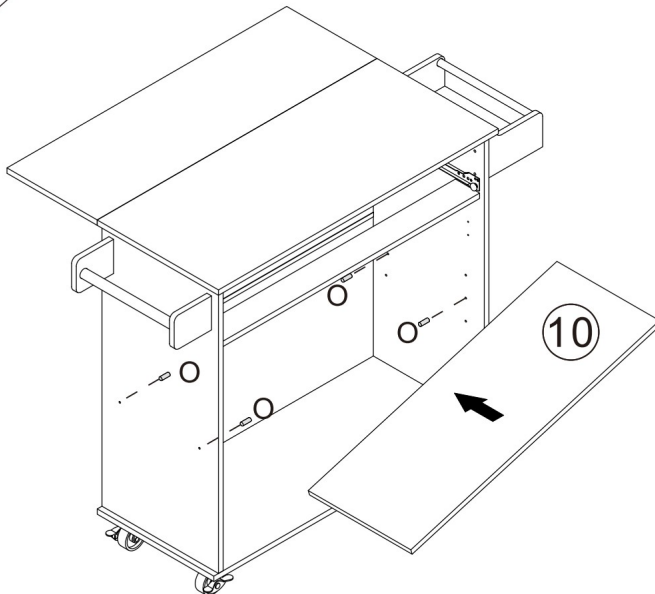

Ox4

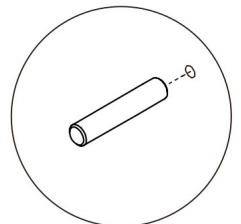



15

x2

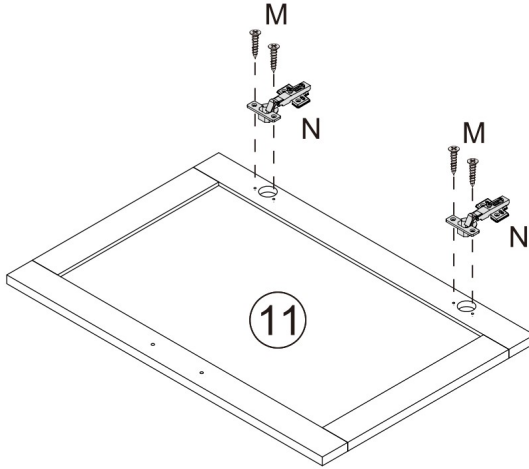
 M4*14	Mx8
	Nx4



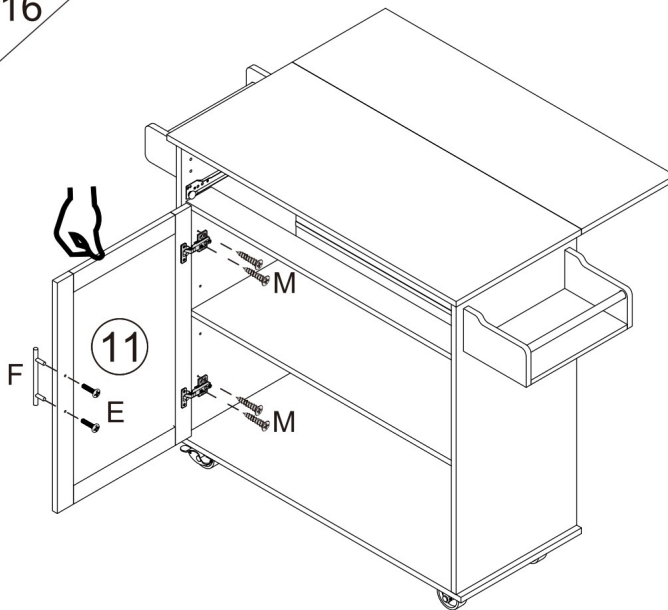

16

 M4*20	Ex2
	Fx1
 M4*14	Mx4



17

 M4*20	E x2
	F x1
 M4*14	M x4

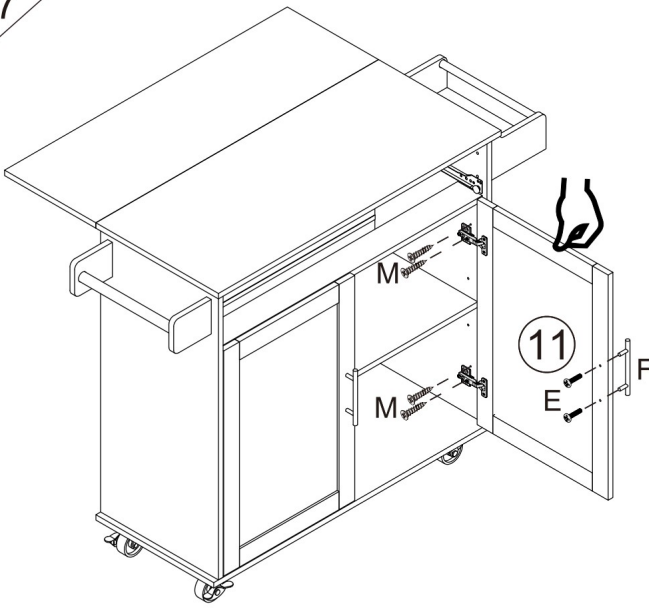

18

 M4*14	M x8
---	-------------

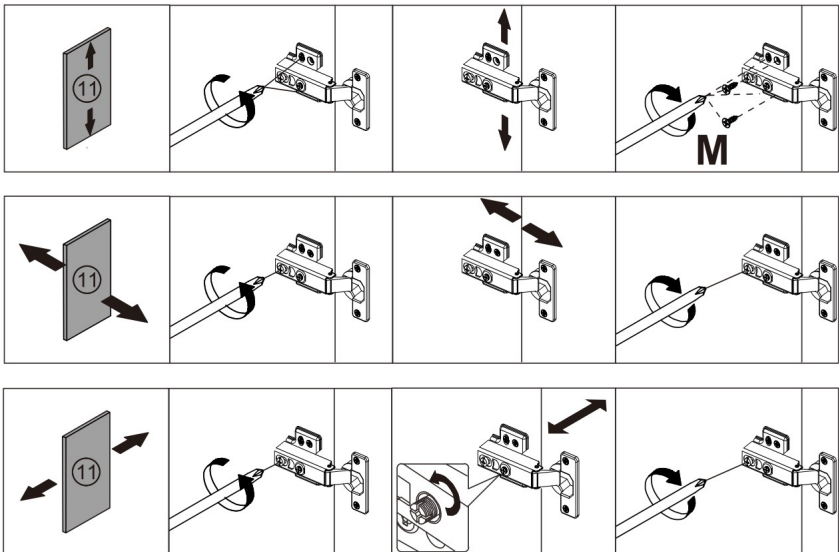

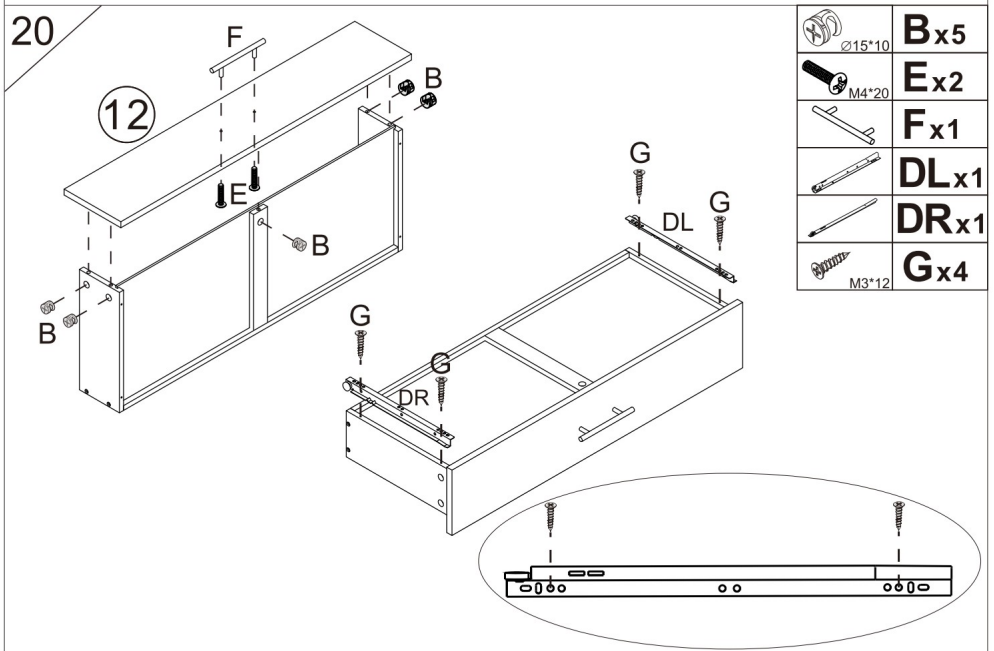
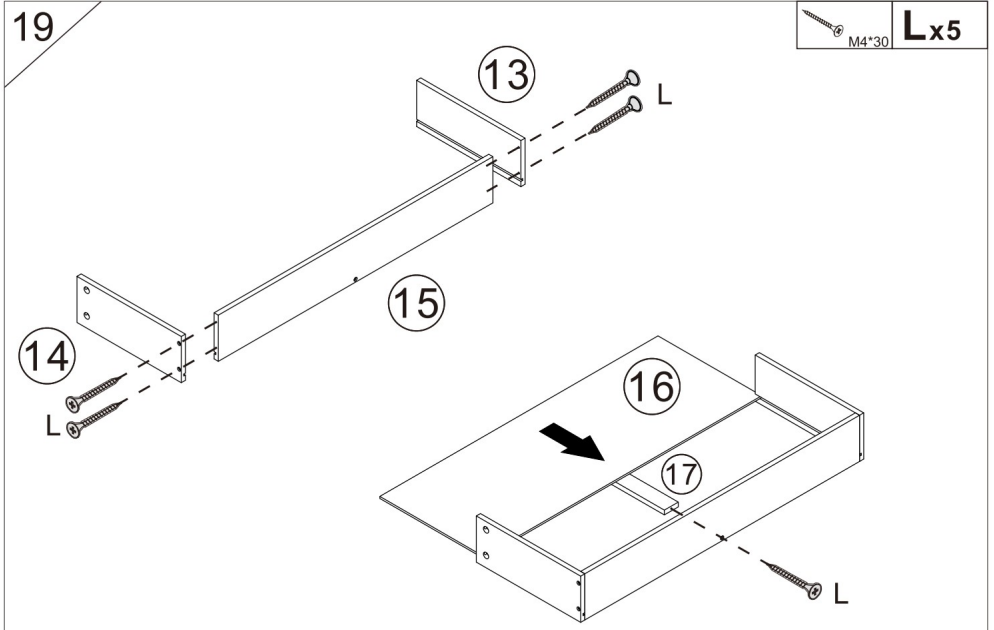

21

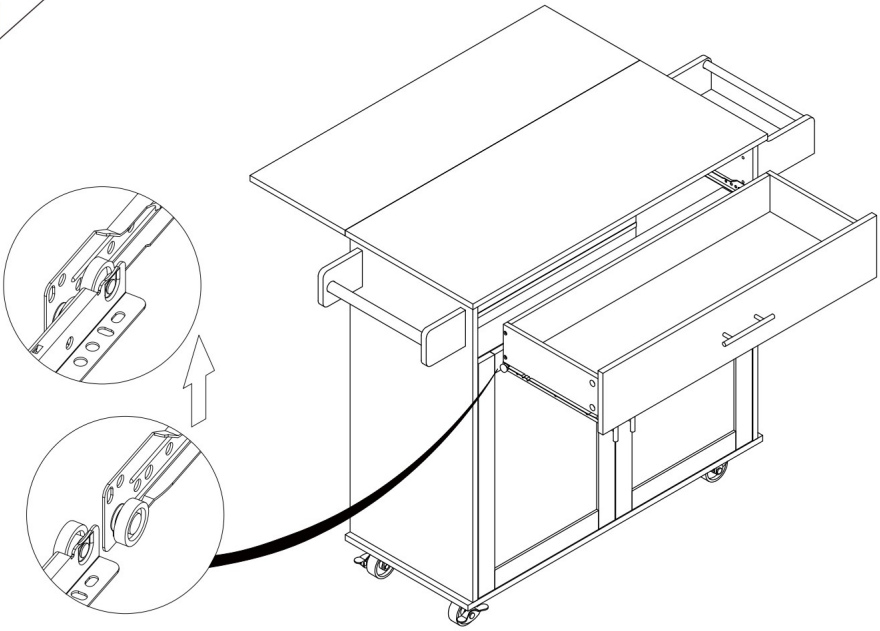

22

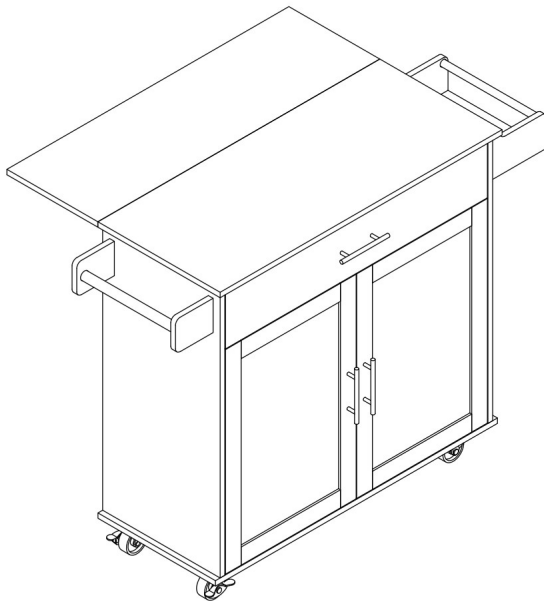

General Care

1. Make sure each layer should not exceed 40lb loading weight.
2. Make sure Folding board should not exceed 37lb loading weight.

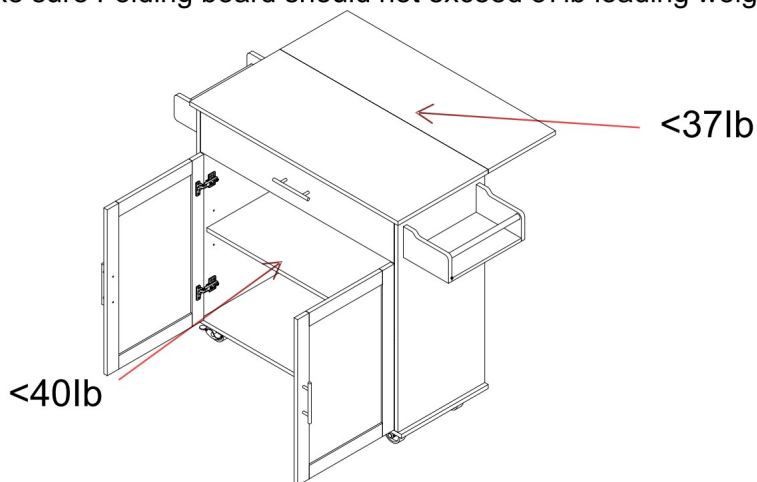

3. Make sure each drawer should not exceed 28lb loading weight.

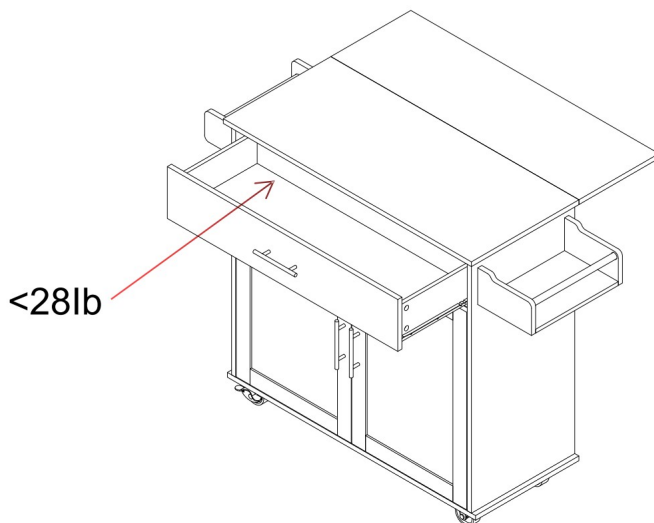

Cleaning

-For cleaning, wipe the surface with a damp (not wet) cloth or wipe dry with a clean lint free cotton cloth.

Produttore: Shanghaimuxinmuyeyouxiangongsi

Indirizzo: Shuangchenglu 803nong11hao1602A-1609shi, baoshanqu, shanghai 200000 CN.

Importato in AUS: SIHAO PTY LTD. 1 ROKEVA STREETEASTWOOD NSW 2122 Australia

Importato negli USA: Sanven Technology Ltd. Suite 250, 9166 Anaheim Place, Rancho Cucamonga, CA 91730



E-CrossStu GmbH
Mainzer Landstr.69, 60329 Francoforte sul Meno.



CONSULENZA YH LIMITATA.
C/O YH Consulting Limited Ufficio 147, Centurion House, London
Road, Staines-upon-Thames, Surrey, TW18 4AX

VEVOR[®]

TOUGH TOOLS, HALF PRICE

Support and E-Warranty Certificate <https://www.vevor.com/support>

VEVOR[®]

TOUGH TOOLS, HALF PRICE

Technical Support and E-Warranty Certificate www.vevor.com/support

KITCHEN ISLAND USER MANUAL

MODEL:SR221264

We continue to be committed to provide you tools with competitive price.

"Save Half", "Half Price" or any other similar expressions used by us only represents an estimate of savings you might benefit from buying certain tools with us compared to the major top brands and hence not necessarily mean to cover all categories of tools offered by us. You are kindly reminded to verify carefully when you are placing an order with us if you are actually saving half in comparison with the top major brands.

VEVOR®

TOUGH TOOLS, HALF PRICE

**KITCHEN ISLAND
(MODEL:SR221264)**

Thanks for purchasing one of our products, please read carefully the assembly instructions before the installation.

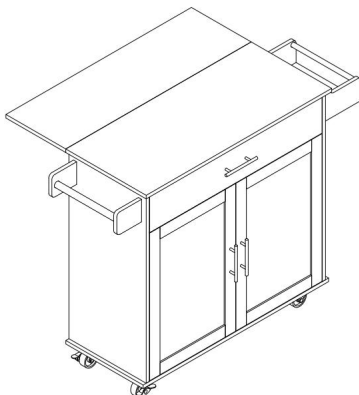

Model: SR221264

NEED HELP? CONTACT US!

Have product questions? Need technical support? Please feel free to contact us:

Soporte técnico y certificado de garantía
electrónica www.vevor.com/support

This is the original instruction, please read all manual instructions carefully before operating. VEVOR reserves a clear interpretation of our user manual. The appearance of the product shall be subject to the product you received. Please forgive us that we won't inform you again if there are any technology or software updates on our product.

PRODUCT PARAMETERS

Model	ProductSize/mm (When the folding board is opened)	Loading Capacity	Top panel size(mm)
SR221264	1190x695x905	200 lb (Max)	900x390 900x290 (Folding board)

ASSEMBLY PRECAUTIONS

1. Assemble needs to follow these instructions. Incorrect assembly can be a hazard.
2. Wear safety goggles and heavy-duty work gloves during assembly.
3. Do not assemble when tired or under the influence of alcohol, drugs or medication.
4. Weight capacity and other product capabilities only apply to a wholly and correctly assembled product.
5. Keep the assembly area clean and well-lit.
6. Keep bystanders out of the area during assembly.
7. The weight of plate is heavy; pay attention to the installation to avoid hurting it, and if necessary, find someone to assist with the installation.

El montaje de este carrito tardará aproximadamente 2 horas, se recomienda que lo operen 2 personas.

USE PRECAUTIONS





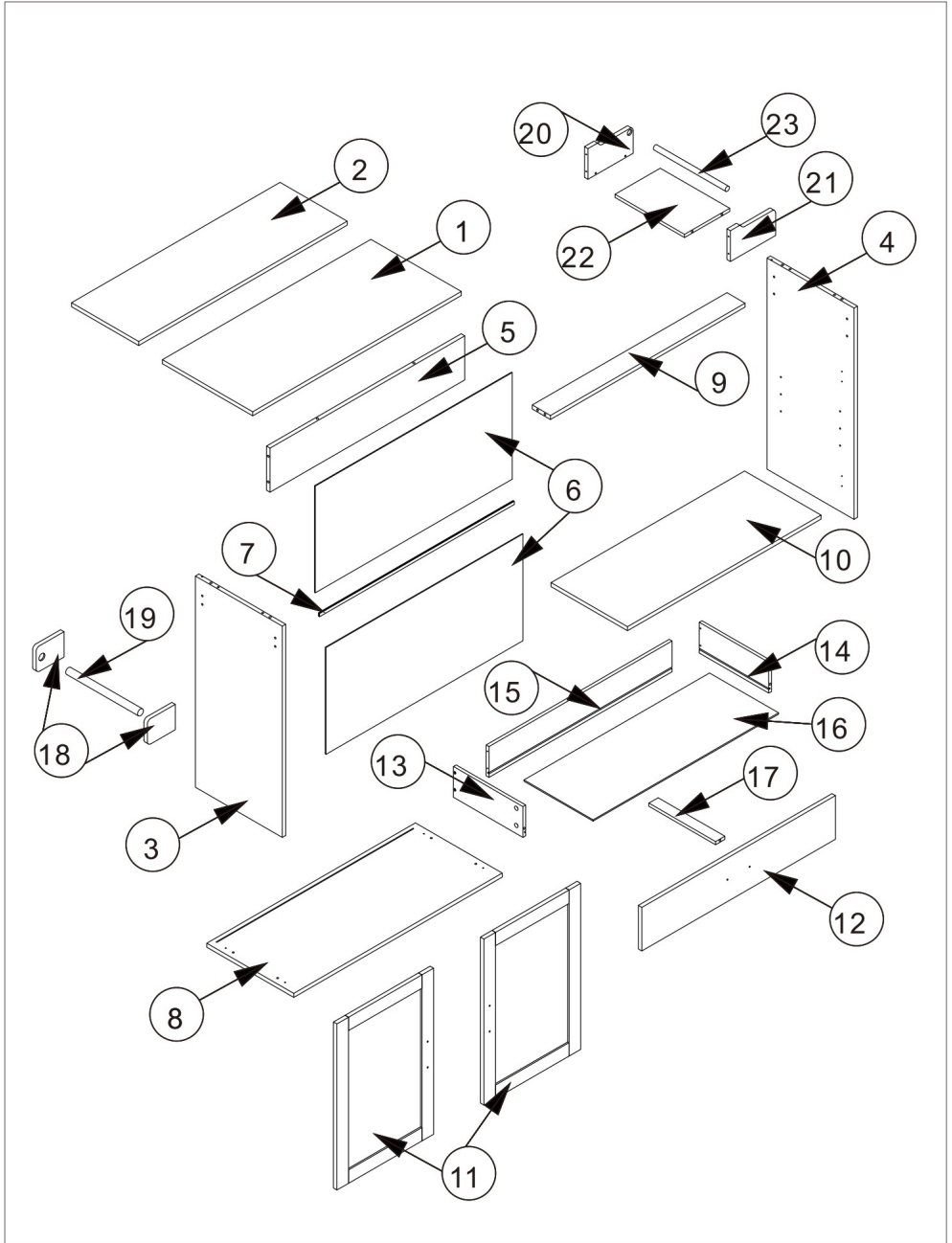

WARNING: TO PREVENT SERIOUS INJURY AND DEATH FROM TIPPING:

1. This product is not a toy. Do not allow children to play with or approach this item.
2. Use as intended only. Do not sit or stand on the product.
3. Inspect before every use. Do not use it if parts are loose or damaged.
4. Use on flat, level, and hard surfaces only.
5. Do not exceed the listed weight capacity. Tighten all knobs securely before applying load. Be aware of dynamic loading! The sudden load movement may briefly create an excess load, causing product failure.



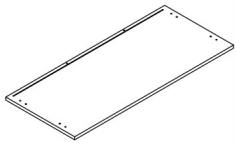
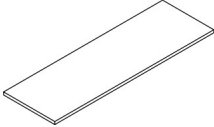
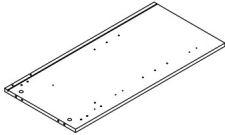
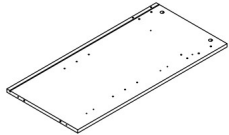
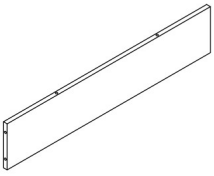
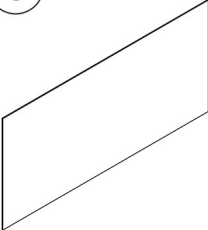

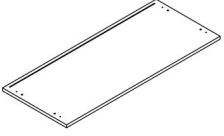
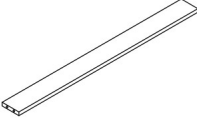
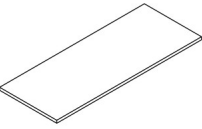
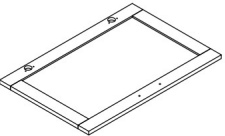
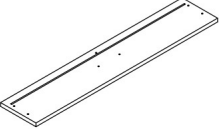

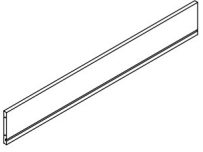
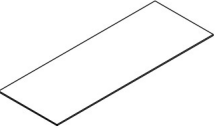

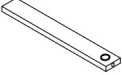
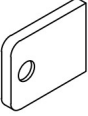
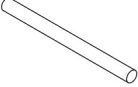
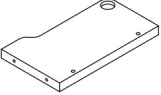
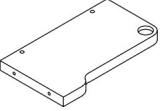
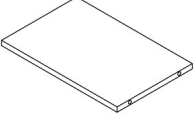
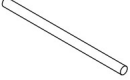











Exploded Drawing



PARTS LIST

<p>1</p>  <p>1 PC</p>	<p>2</p>  <p>1 PC</p>	<p>3</p>  <p>1 PC</p>	<p>4</p>  <p>1 PC</p>
<p>5</p>  <p>1 PC</p>	<p>6</p>  <p>2 PCS</p>	<p>7</p>  <p>1 PC</p>	<p>8</p>  <p>1 PC</p>
<p>9</p>  <p>1 PC</p>	<p>10</p>  <p>1 PC</p>	<p>11</p>  <p>2 PCS</p>	<p>12</p>  <p>1 PC</p>
<p>13</p>  <p>1 PC</p>	<p>14</p>  <p>1 PC</p>	<p>15</p>  <p>1 PC</p>	<p>16</p>  <p>1 PC</p>

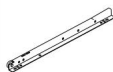
<p>17</p>  <p>1 PC</p>	<p>18</p>  <p>2 PCS</p>	<p>19</p>  <p>1 PC</p>	<p>20</p>  <p>1 PC</p>
<p>21</p>  <p>1 PC</p>	<p>22</p>  <p>1 PC</p>	<p>23</p>  <p>1 PC</p>	

A M6*35  23 PCS +1repuesto	B Ø15*10  23 PCS +1repuesto	C Ø6*30  8 PCS	D M4*35  4 PCS	E M4*20  6 PCS	F  3 PCS	G M3*12  8 PCS	H M7*40  8 PCS
I M5*14  26 PCS +1repuesto	J  2 PCS	K  2 PCS	L M4*30  5 PCS	M M4*14  24 PCS +1repuesto	N  4 PCS	O  4 PCS	P  2 PCS
Q  1 PC	CL  1 PC	CR  1 PC	DL  1 PC	DR  1 PC			

Cam Lock Fastening System

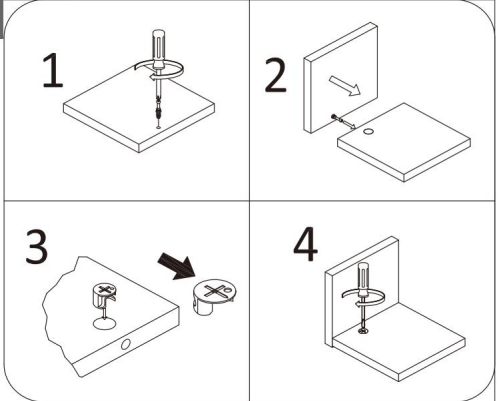
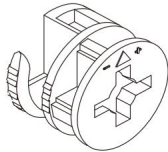

This Cam Lock Fastening System will be used throughout the assembly process

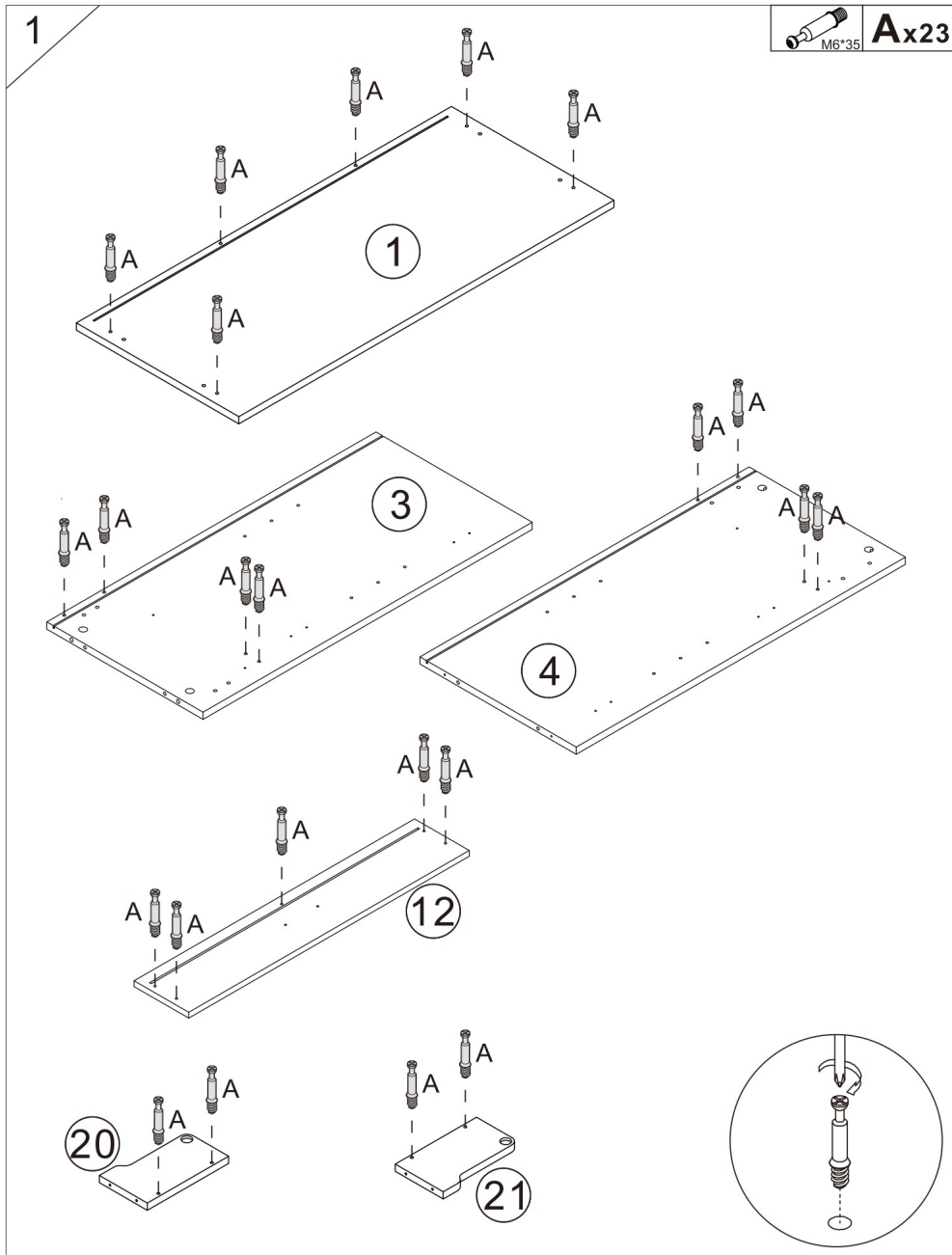

ASSEMBLY STEPS



2

	CLx1
	CRx1
 M3*12	Gx4

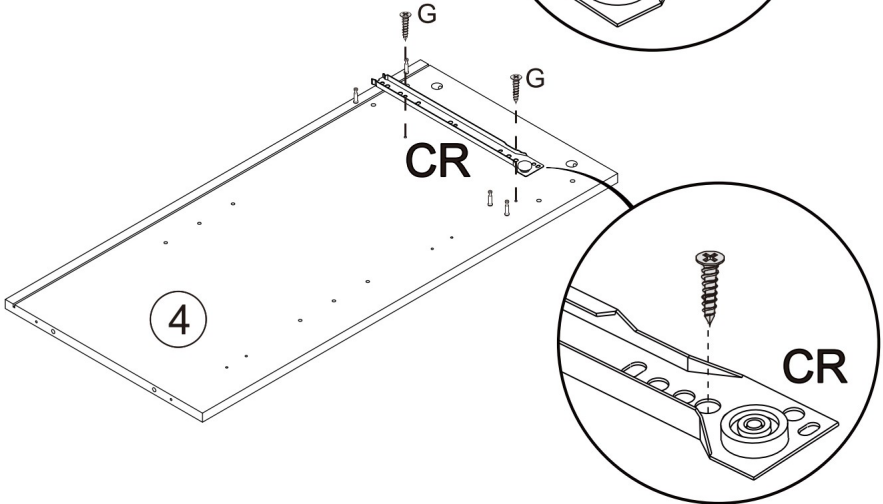
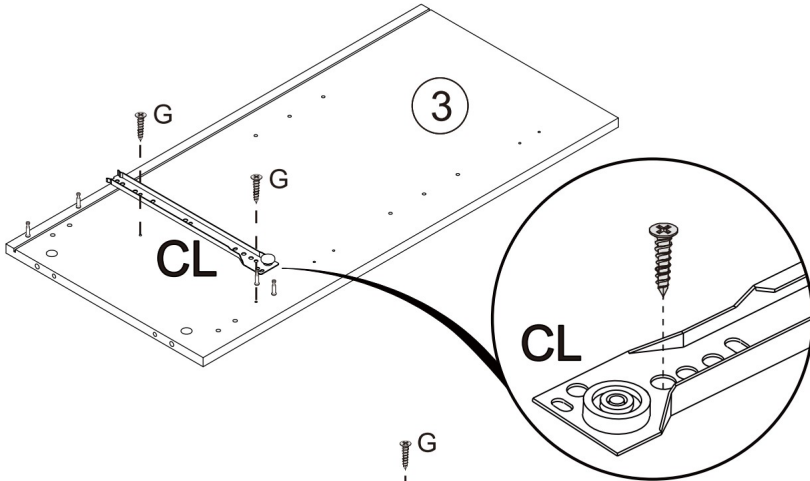

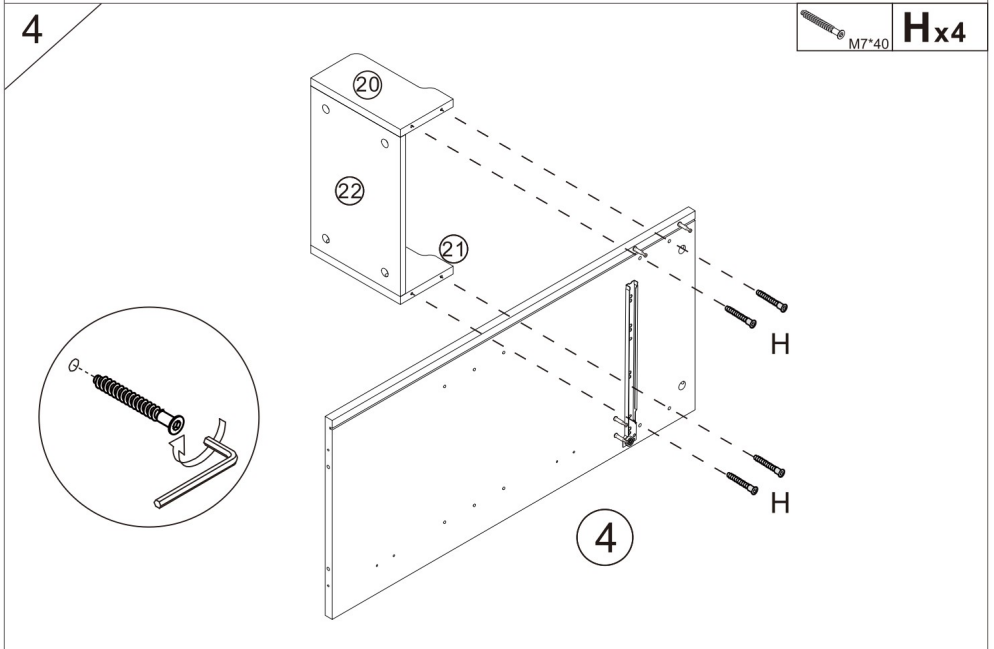
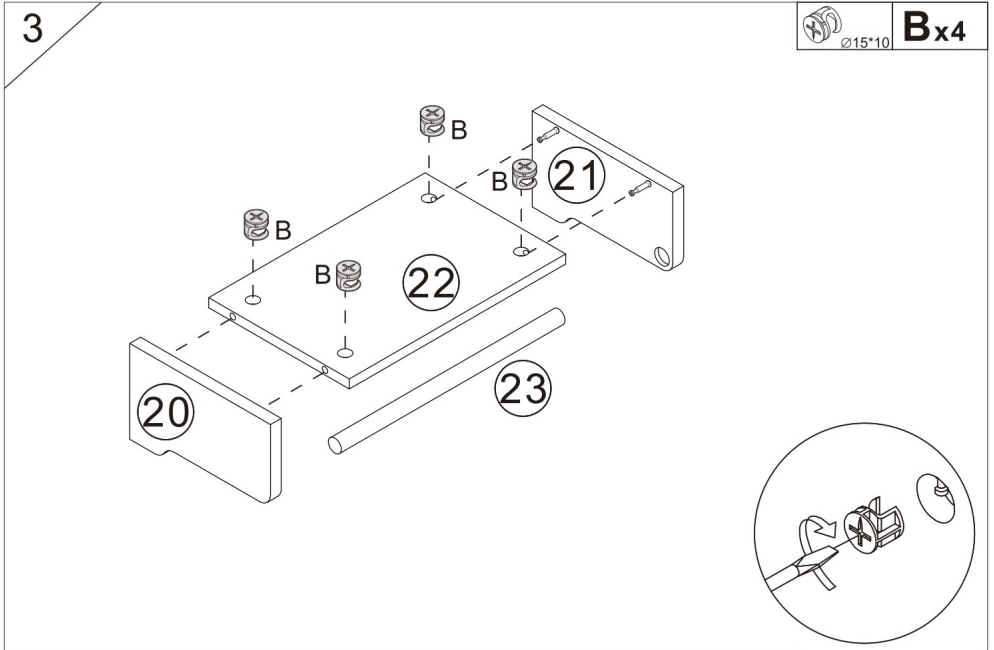

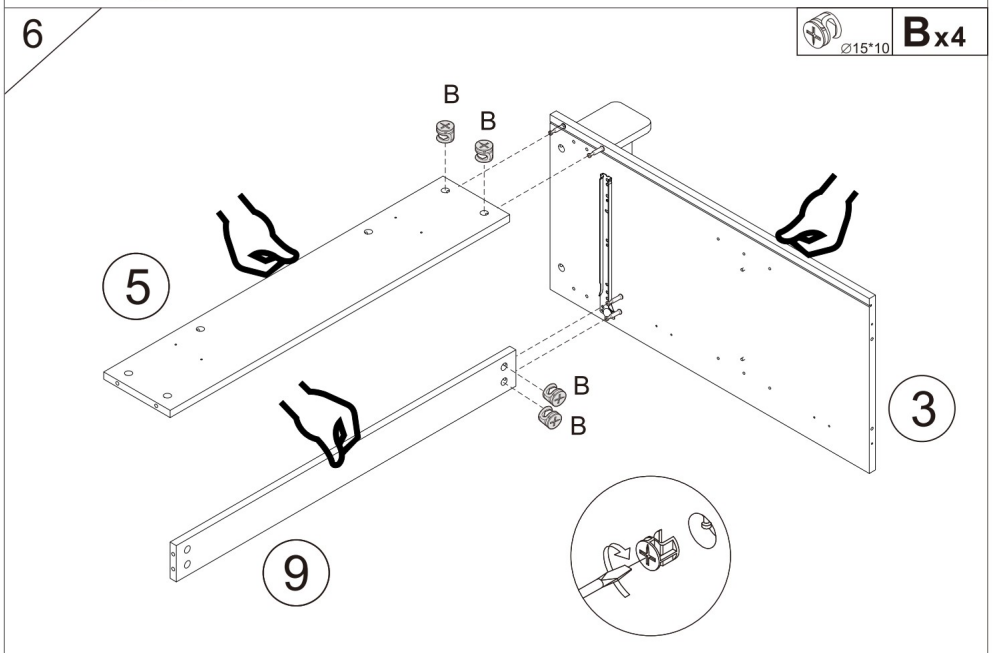
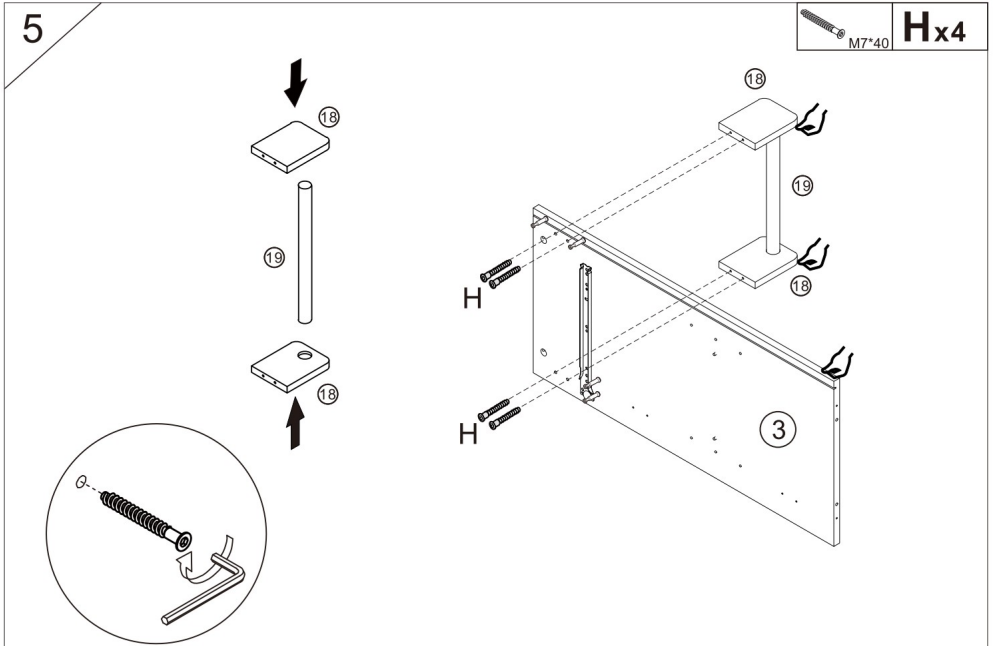

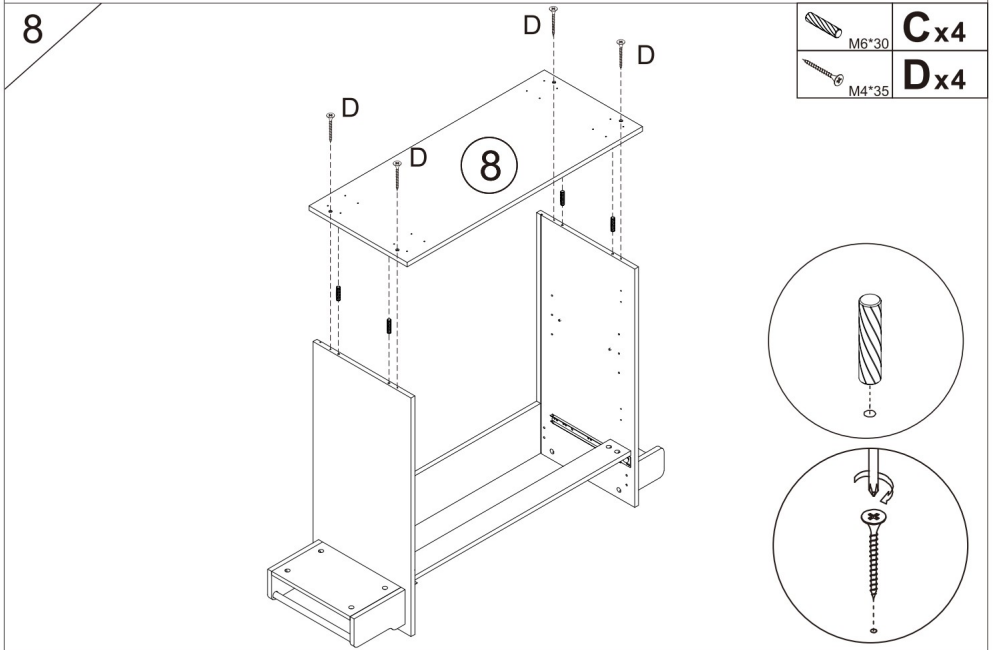
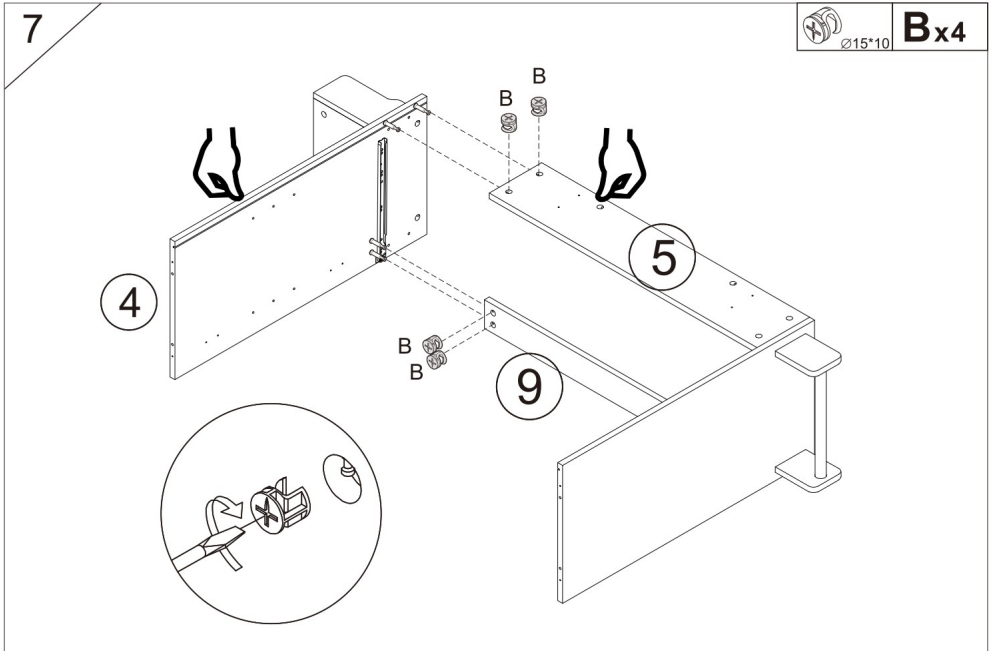

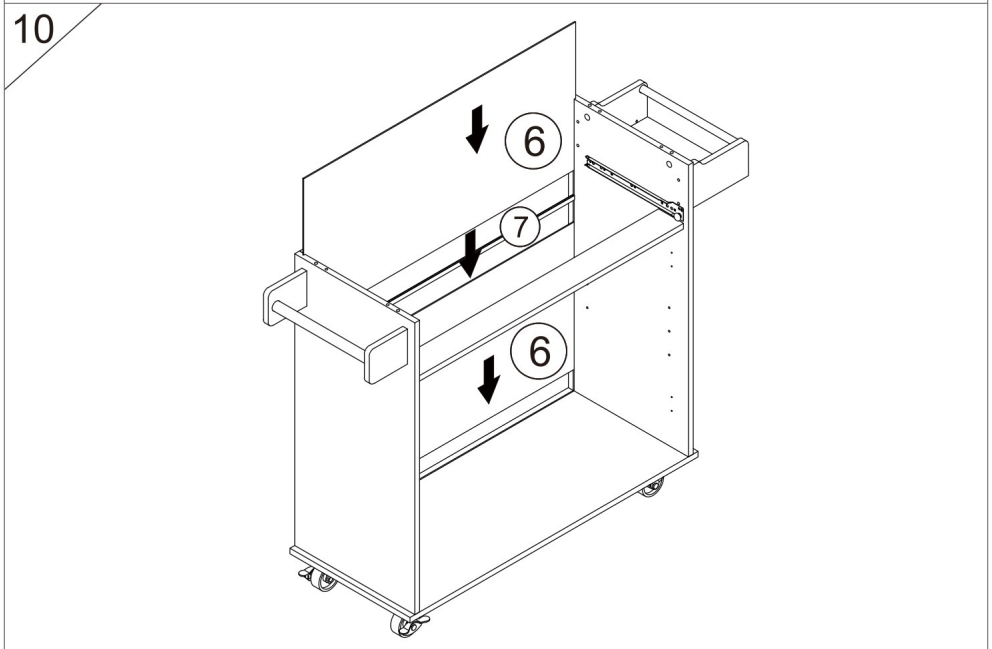
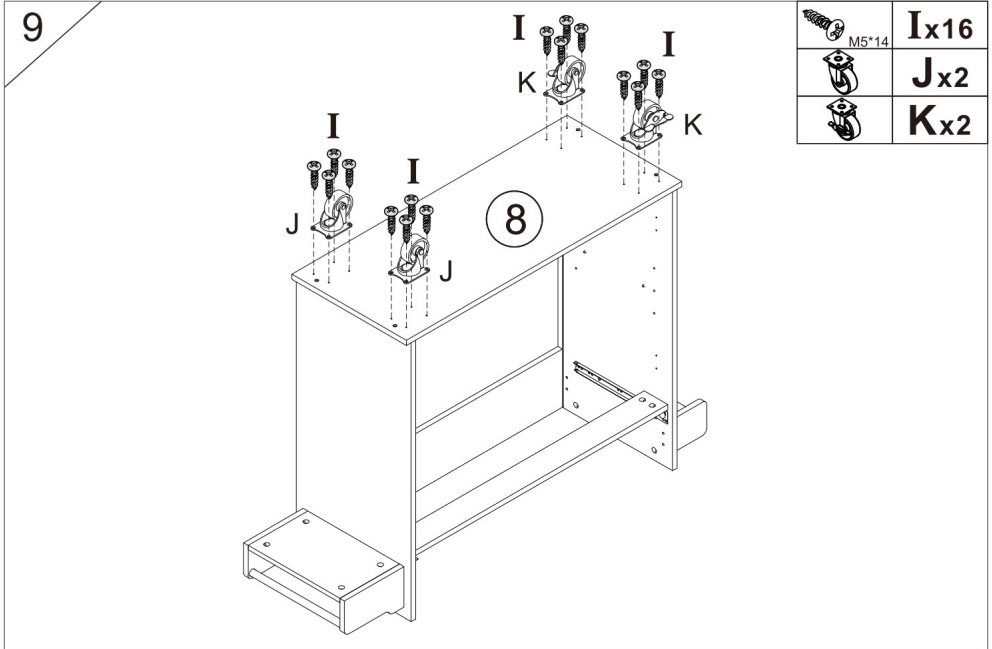

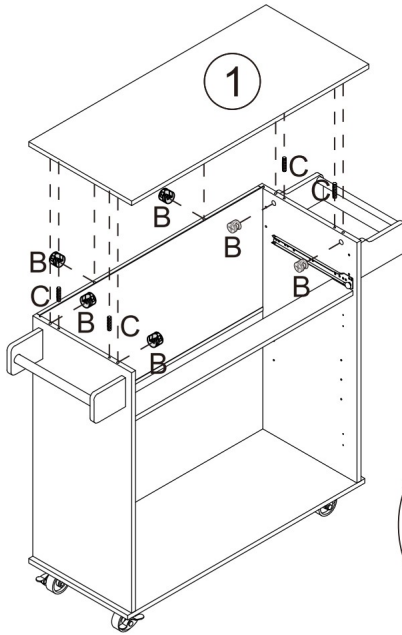

11



 $\varnothing 15 \times 10$	B x6
 M6 x 30	C x4

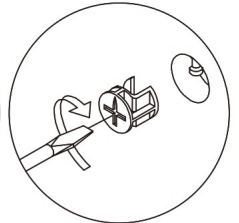
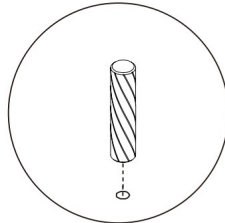

12

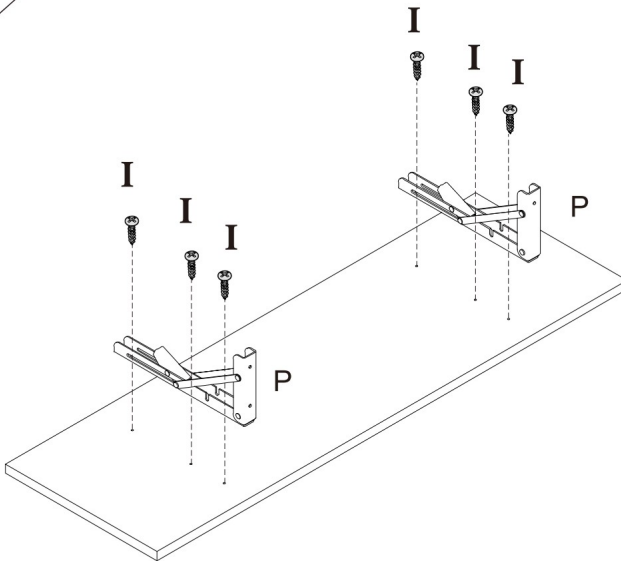

 M5 x 14	I x6
	P x2

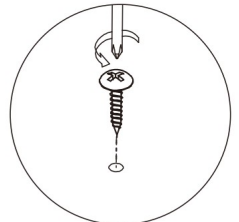
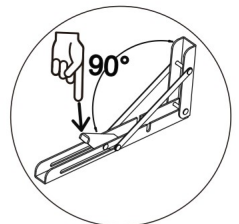

13

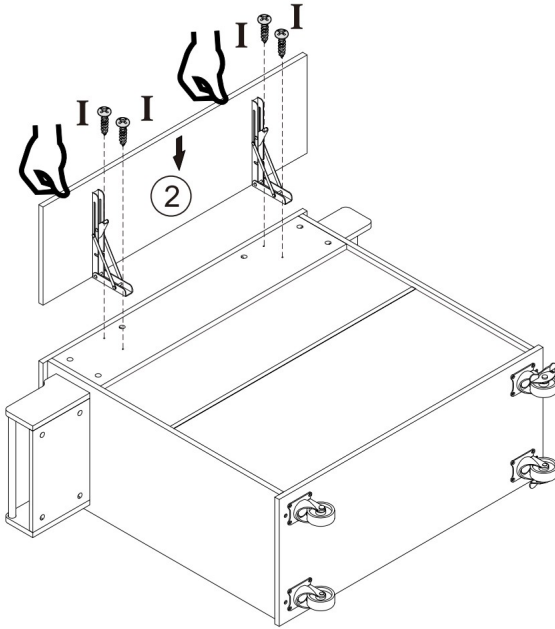

M5*14 **I**x4

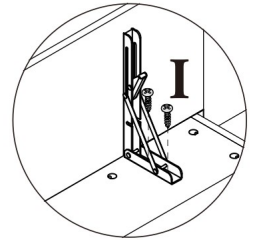
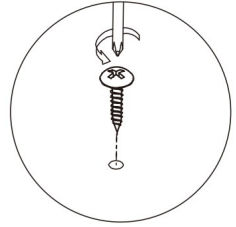

14

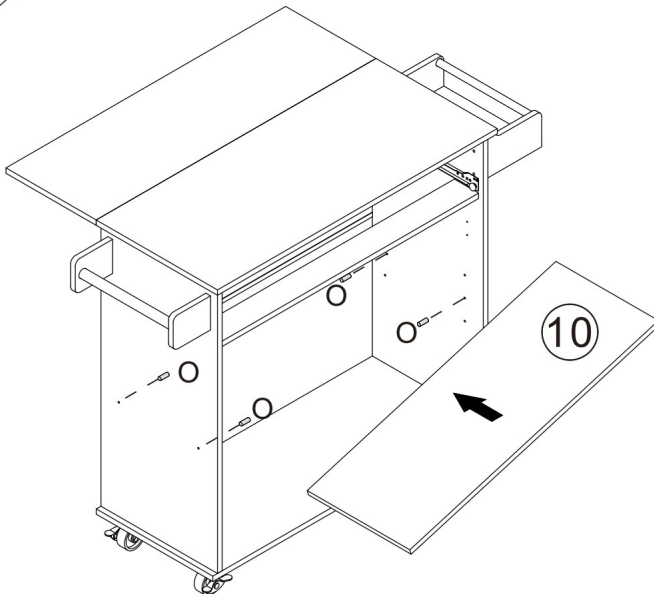

Ox4

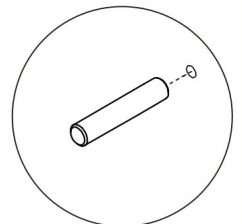



15

x2

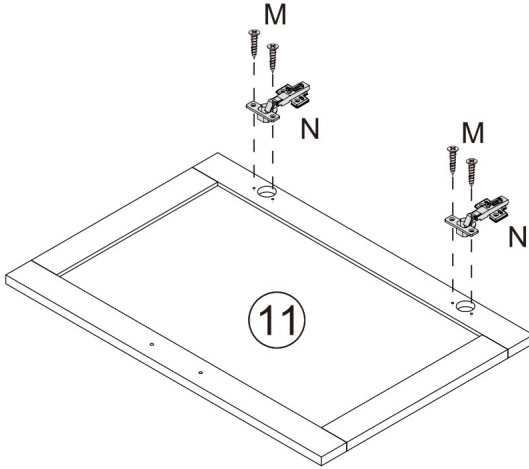
 M4*14	M_{x8}
	N_{x4}



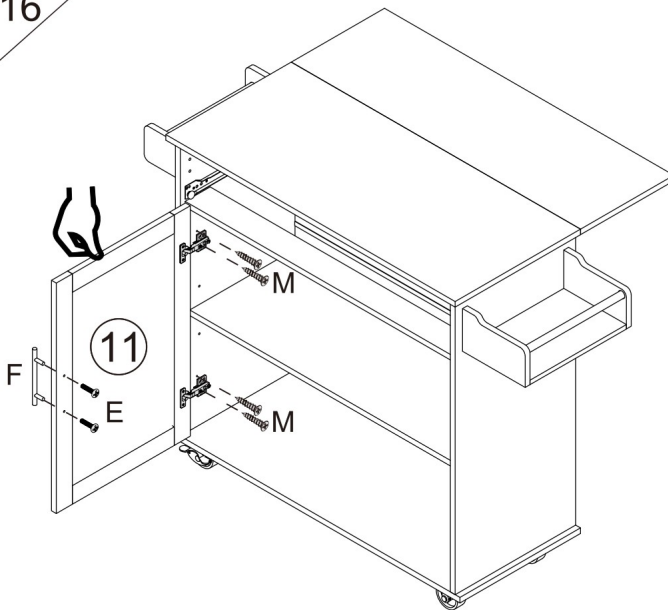

16

 M4*20	E_{x2}
	F_{x1}
 M4*14	M_{x4}



17

 M4*20	E x2
	F x1
 M4*14	M x4

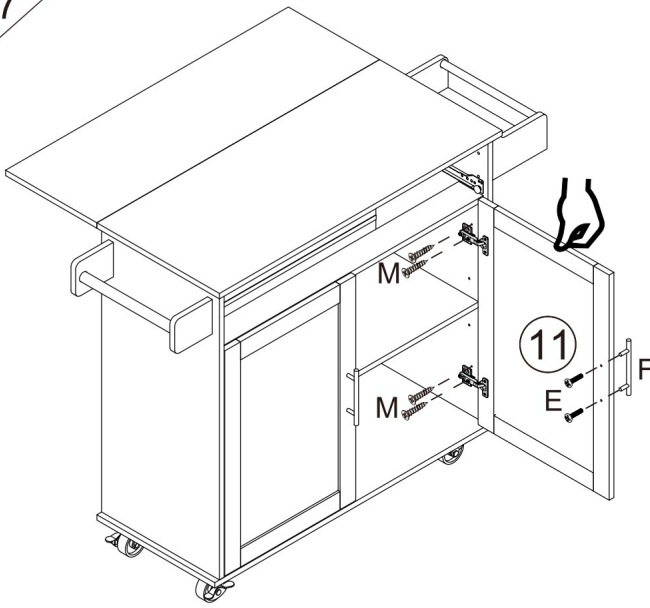

18

 M4*14	M x8
---	-------------

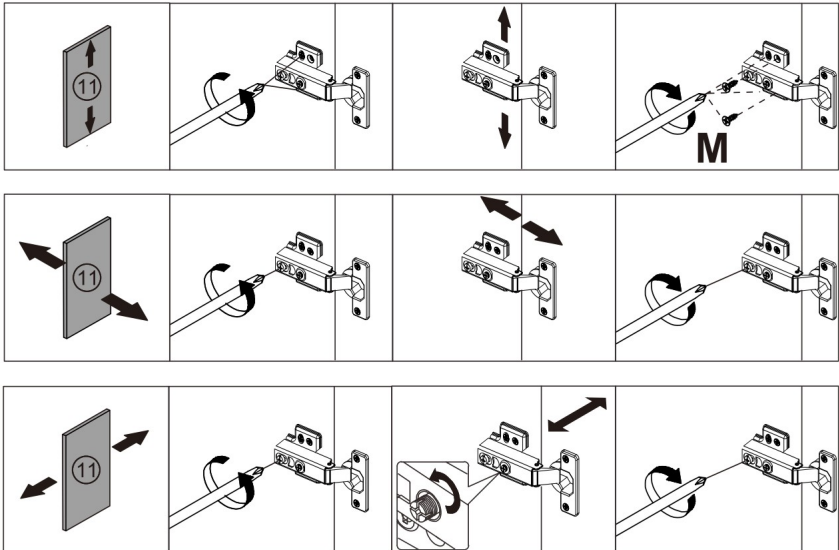

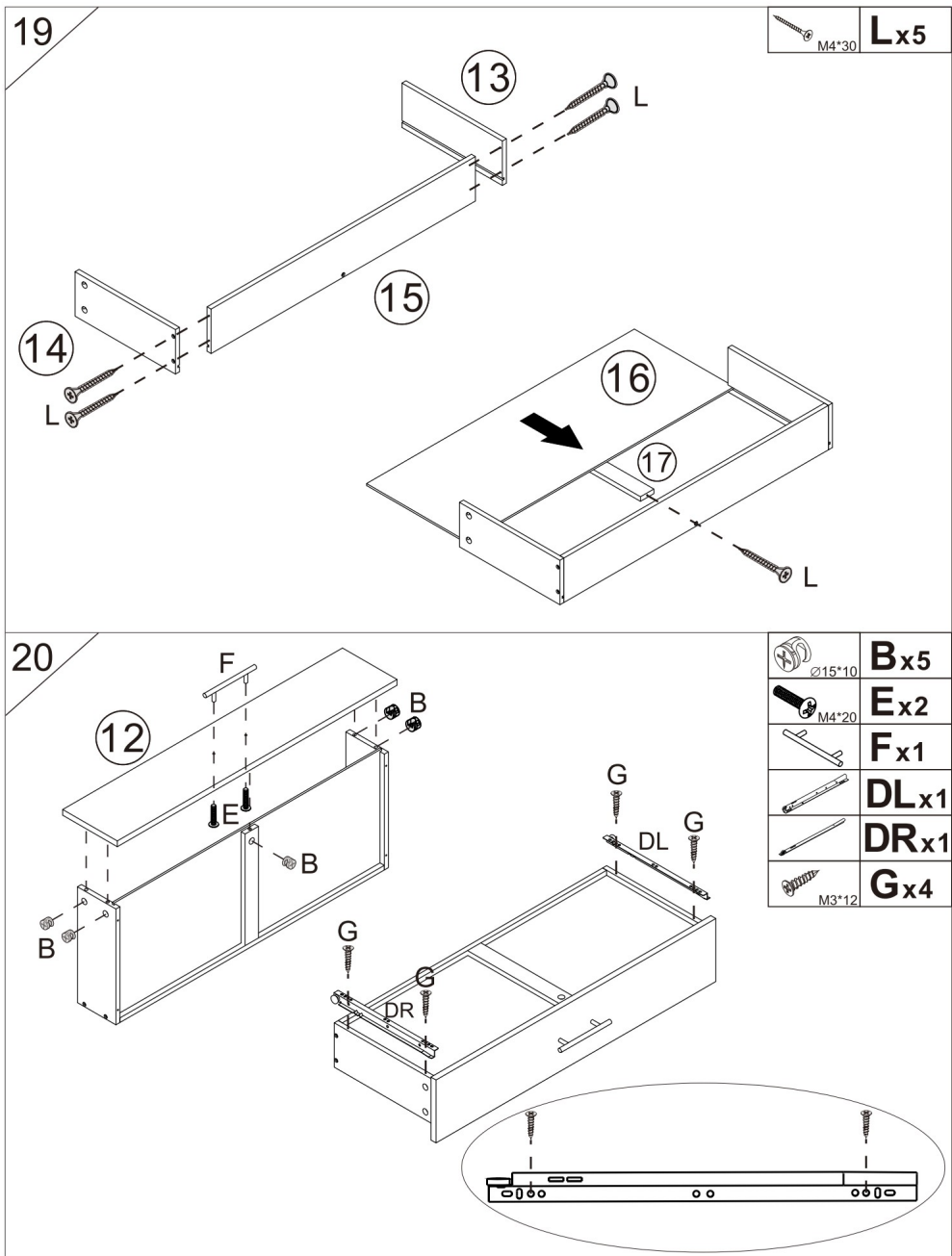

21

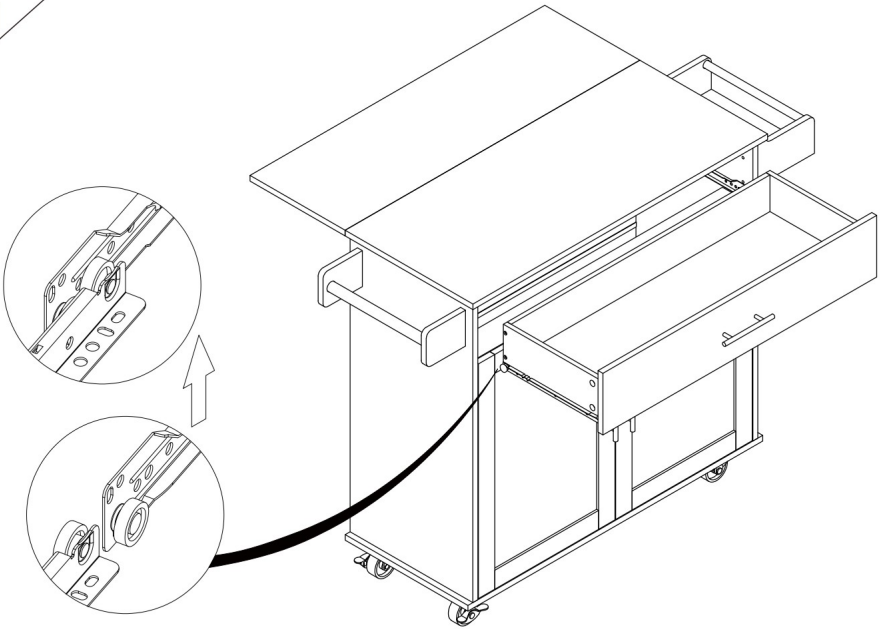

22

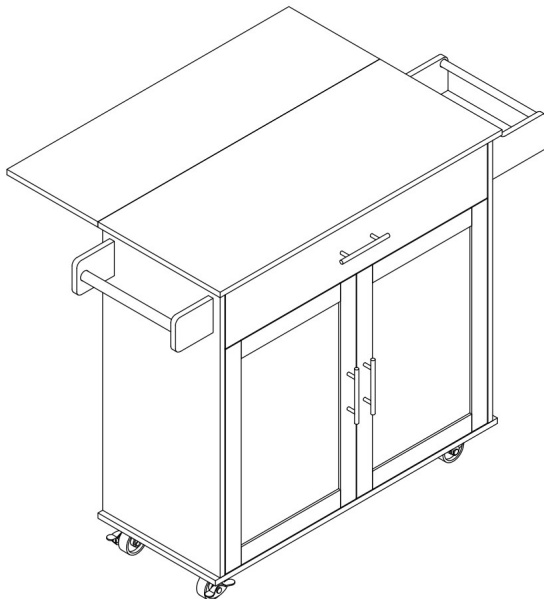

General Care

1. Make sure each layer should not exceed 40lb loading weight.
2. Make sure Folding board should not exceed 37lb loading weight.

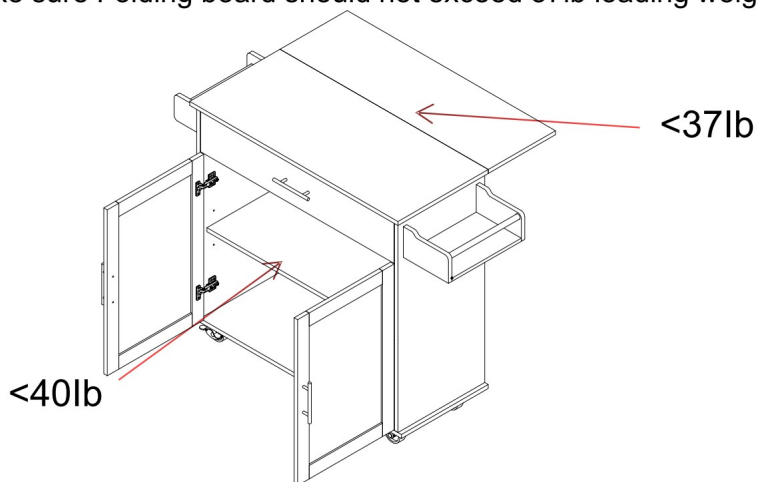

3. Make sure each drawer should not exceed 28lb loading weight.

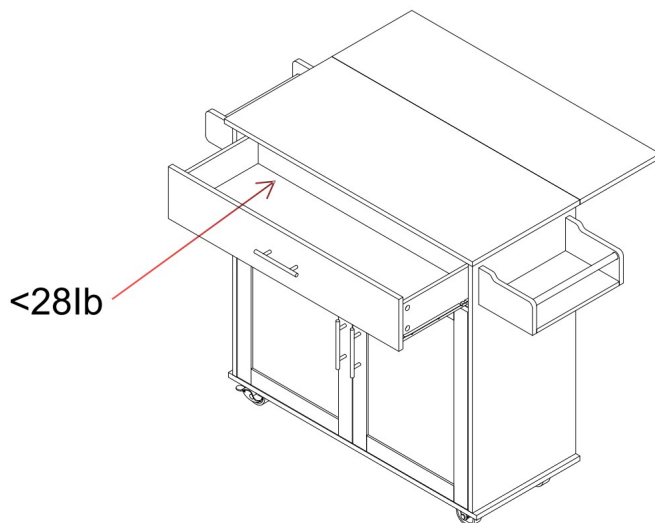

Cleaning

-For cleaning, wipe the surface with a damp (not wet) cloth or wipe dry with a clean lint free cotton cloth.

Fabricante: Shanghaimuxinmuyeyouxiangongsi

Dirección: Shuangchenglu 803nong11hao1602A-1609shi, baoshanqu, shanghai 200000 CN.

Importado a AUS: SIHAO PTY LTD. 1 ROKEVA STREETEASTWOOD NSW 2122 Australia

Importado a EE. UU.: Sanven Technology Ltd. Suite 250, 9166 Anaheim Place, Rancho Cucamonga, CA 91730



E-CrossStu GmbH
Mainzer Landstr.69, 60329 Fráncfort del Meno.



YH CONSULTING LIMITADA.
C/O YH Consulting Limited Oficina 147, Centurion House,
London Road, Staines-upon-Thames, Surrey, TW18 4AX

VEVOR[®]

TOUGH TOOLS, HALF PRICE

Support and E-Warranty Certificate <https://www.vevor.com/support>

VEVOR[®]

TOUGH TOOLS, HALF PRICE

Technical Support and E-Warranty Certificate www.vevor.com/support

KITCHEN ISLAND USER MANUAL

MODEL:SR221264

We continue to be committed to provide you tools with competitive price.

"Save Half", "Half Price" or any other similar expressions used by us only represents an estimate of savings you might benefit from buying certain tools with us compared to the major top brands and do not necessarily mean to cover all categories of tools offered by us. You are kindly reminded to verify carefully when you are placing an order with us if you are actually saving half in comparison with the top major brands.

VEVOR[®]

TOUGH TOOLS, HALF PRICE

**KITCHEN ISLAND
(MODEL:SR221264)**

Thanks for purchasing one of our products, please read carefully the assembly instructions before the installation.

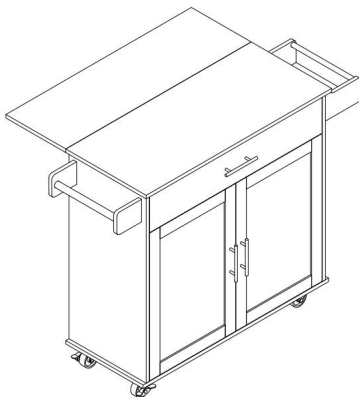

Model: SR221264

NEED HELP? CONTACT US!

Have product questions? Need technical support? Please feel free to contact us:

Wsparcie techniczne i certyfikat gwarancji
elektronicznej www.vevor.com/support

This is the original instruction, please read all manual instructions carefully before operating. VEVOR reserves a clear interpretation of our user manual. The appearance of the product shall be subject to the product you received. Please forgive us that we won't inform you again if there are any technology or software updates on our product.

PRODUCT PARAMETERS

Model	ProductSize/mm (When the folding board is opened)	Loading Capacity	Top panel size(mm)
SR221264	1190x695x905	200 lb (Max)	900x390 900x290 (Folding board)

ASSEMBLY PRECAUTIONS

1. Assemble needs to follow these instructions. Incorrect assembly can be a hazard.
2. Wear safety goggles and heavy-duty work gloves during assembly.
3. Do not assemble when tired or under the influence of alcohol, drugs or medication.
4. Weight capacity and other product capabilities only apply to a wholly and correctly assembled product.
5. Keep the assembly area clean and well-lit.
6. Keep bystanders out of the area during assembly.
7. The weight of plate is heavy; pay attention to the installation to avoid hurting it, and if necessary, find someone to assist with the installation.

Złożenie wózka zajmie około 2 godzin, zaleca się, aby obsługiwały go 2 osoby.

USE PRECAUTIONS





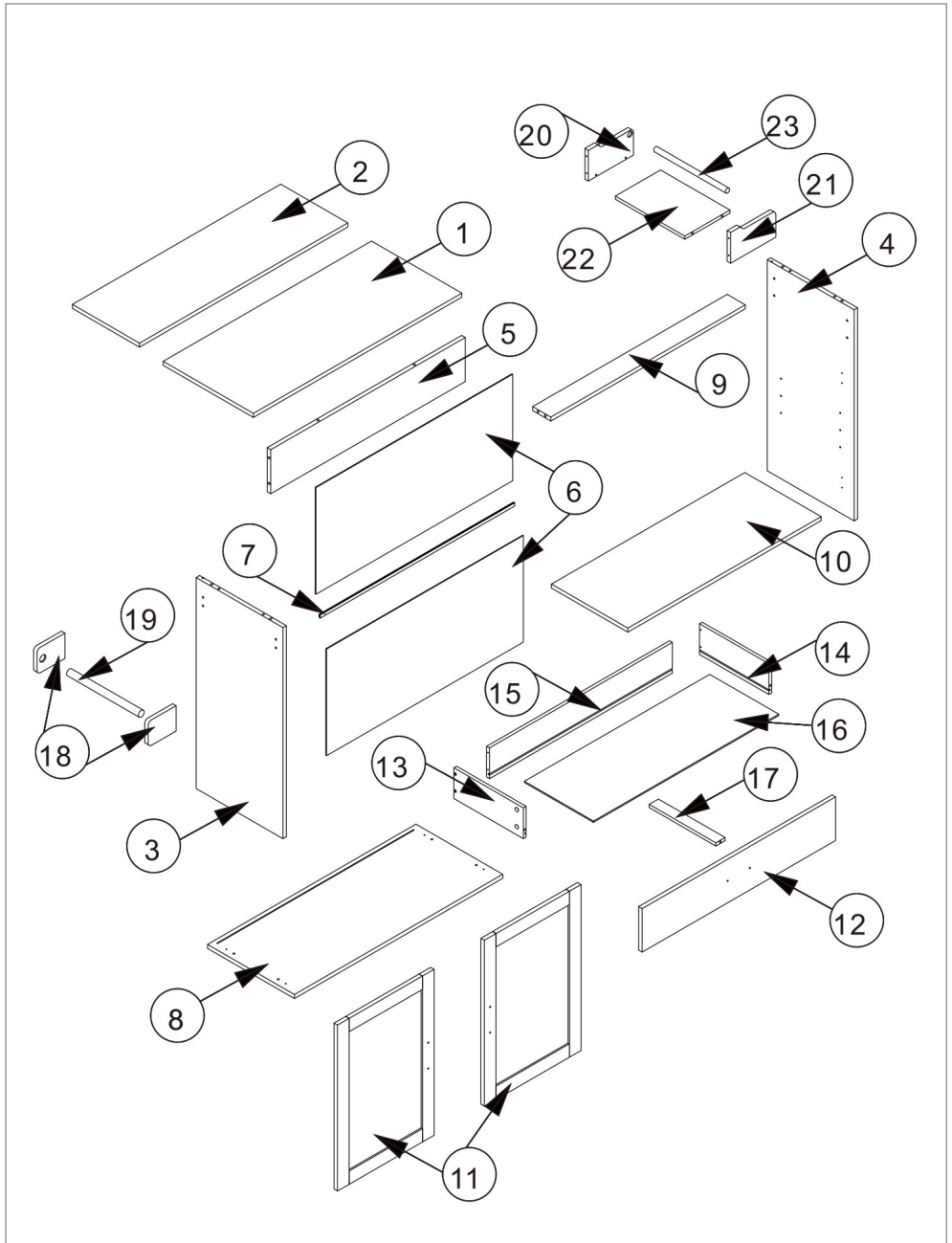

WARNING: TO PREVENT SERIOUS INJURY AND DEATH FROM TIPPING:

1. This product is not a toy. Do not allow children to play with or approach this item.
2. Use as intended only. Do not sit or stand on the product.
3. Inspect before every use. Do not use it if parts are loose or damaged.
4. Use on flat, level, and hard surfaces only.
5. Do not exceed the listed weight capacity. Tighten all knobs securely before applying load. Be aware of dynamic loading! The sudden load movement may briefly create an excess load, causing product failure.



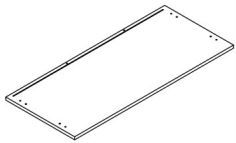
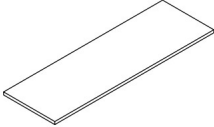
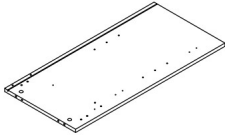
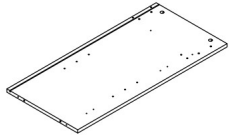
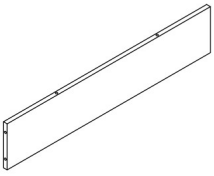
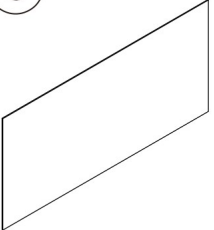

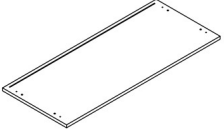
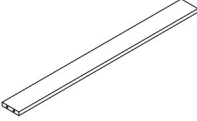
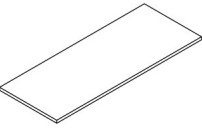
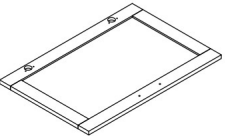
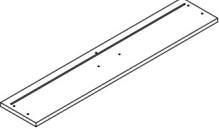

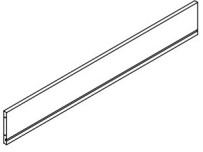
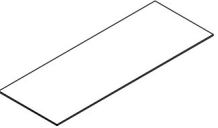

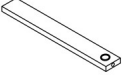
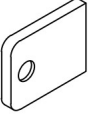
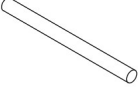
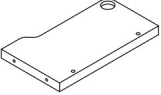
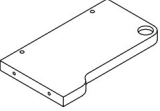
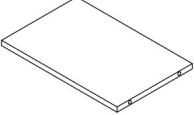
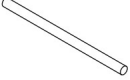











Exploded Drawing



PARTS LIST

<p>1</p>  <p>1 PC</p>	<p>2</p>  <p>1 PC</p>	<p>3</p>  <p>1 PC</p>	<p>4</p>  <p>1 PC</p>
<p>5</p>  <p>1 PC</p>	<p>6</p>  <p>2 PCS</p>	<p>7</p>  <p>1 PC</p>	<p>8</p>  <p>1 PC</p>
<p>9</p>  <p>1 PC</p>	<p>10</p>  <p>1 PC</p>	<p>11</p>  <p>2 PCS</p>	<p>12</p>  <p>1 PC</p>
<p>13</p>  <p>1 PC</p>	<p>14</p>  <p>1 PC</p>	<p>15</p>  <p>1 PC</p>	<p>16</p>  <p>1 PC</p>

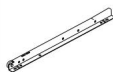
<p>17</p>  <p>1 PC</p>	<p>18</p>  <p>2 PCS</p>	<p>19</p>  <p>1 PC</p>	<p>20</p>  <p>1 PC</p>
<p>21</p>  <p>1 PC</p>	<p>22</p>  <p>1 PC</p>	<p>23</p>  <p>1 PC</p>	

A M6*35  23 PCS *1zapasowy	B Ø15*10  23 PCS *1zapasowy	C Ø6*30  8 PCS	D M4*35  4 PCS	E M4*20  6 PCS	F  3 PCS	G M3*12  8 PCS	H M7*40  8 PCS
I M5*14  26 PCS *1zapasowy	J  2 PCS	K  2 PCS	L M4*30  5 PCS	M M4*14  24 PCS *1zapasowy	N  4 PCS	O  4 PCS	P  2 PCS
Q  1 PC	CL  1 PC	CR  1 PC	DL  1 PC	DR  1 PC			

Cam Lock Fastening System

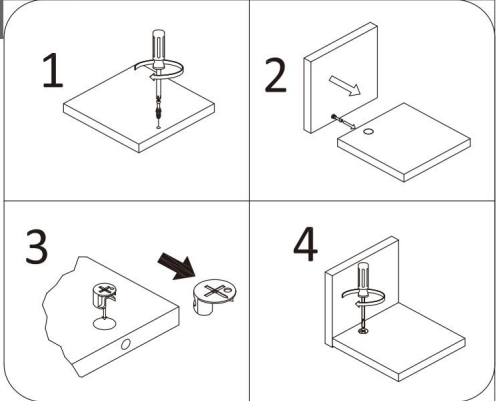
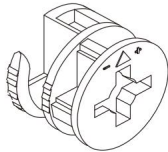

This Cam Lock Fastening System will be used throughout the assembly process

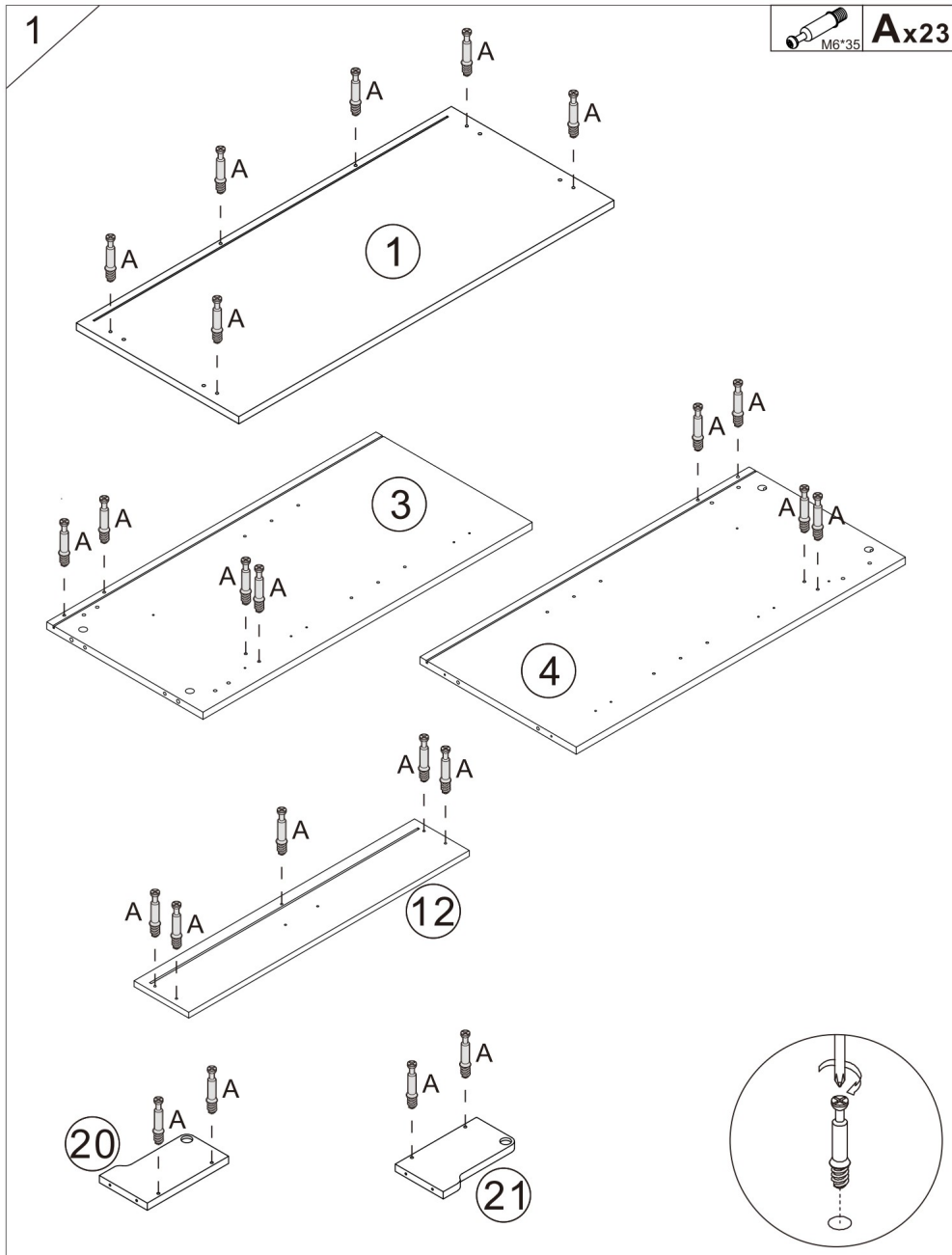

ASSEMBLY STEPS



2

	CLx1
	CRx1
 M3*12	Gx4

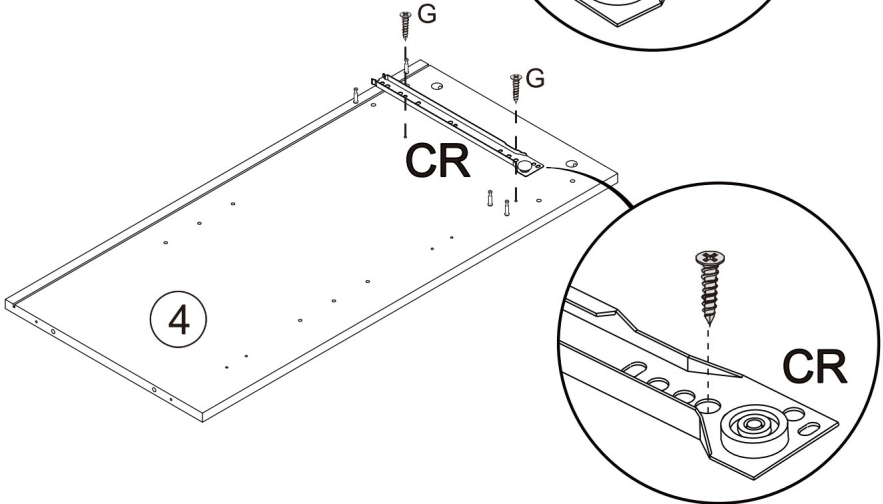
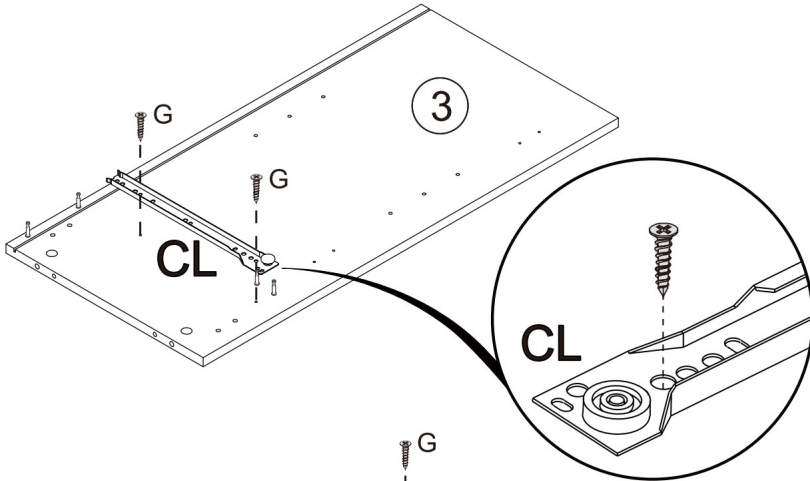

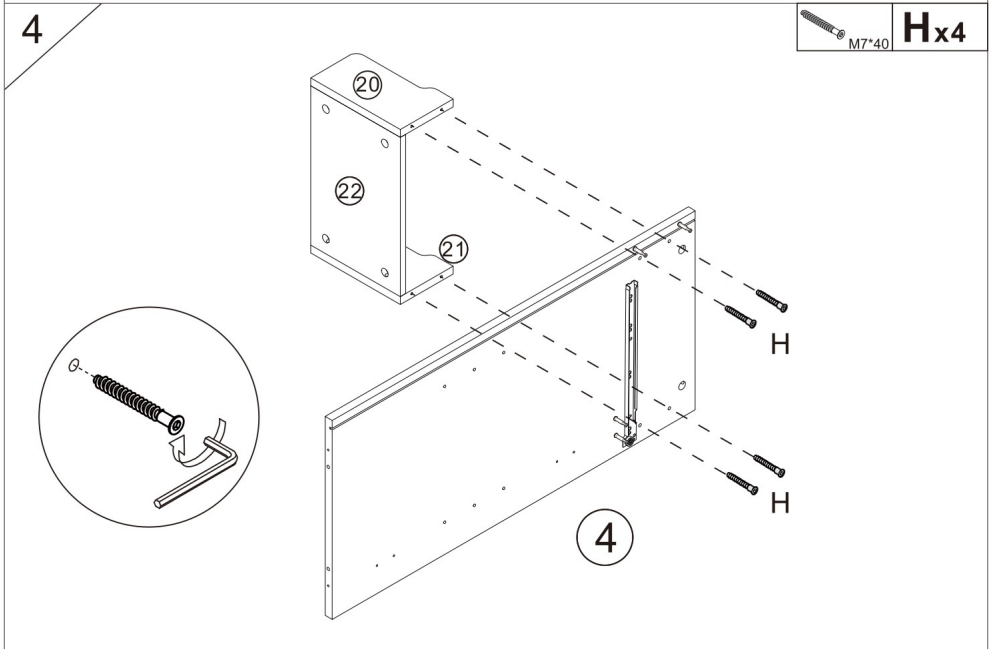
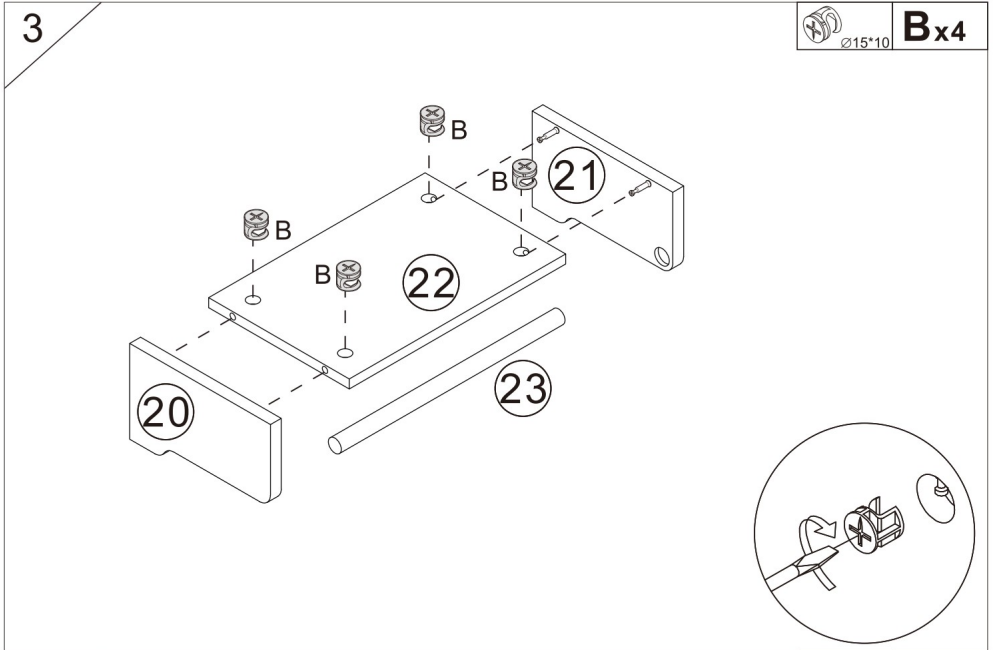

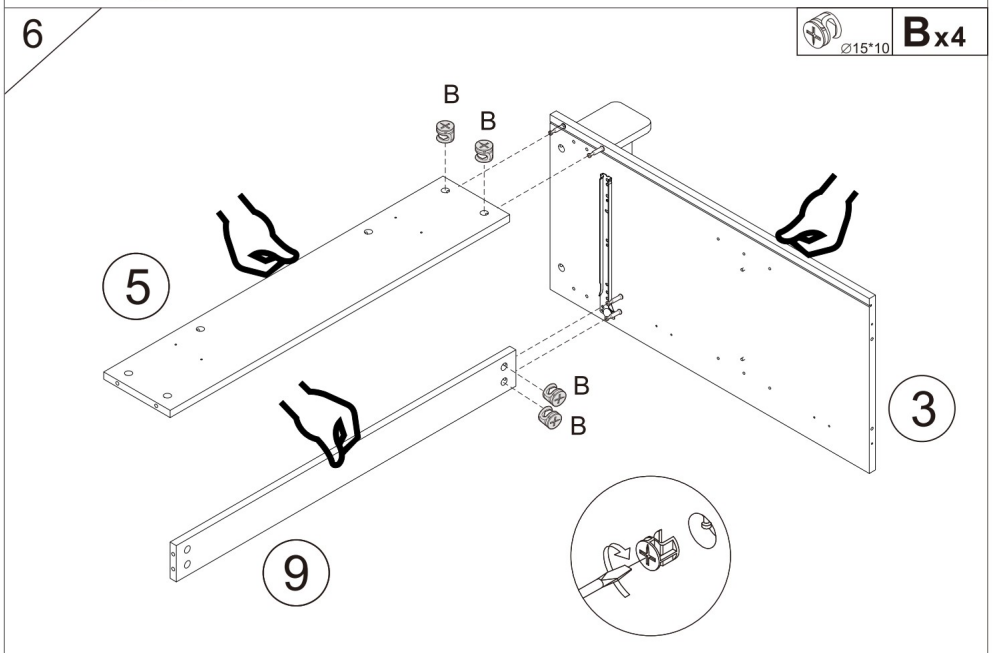
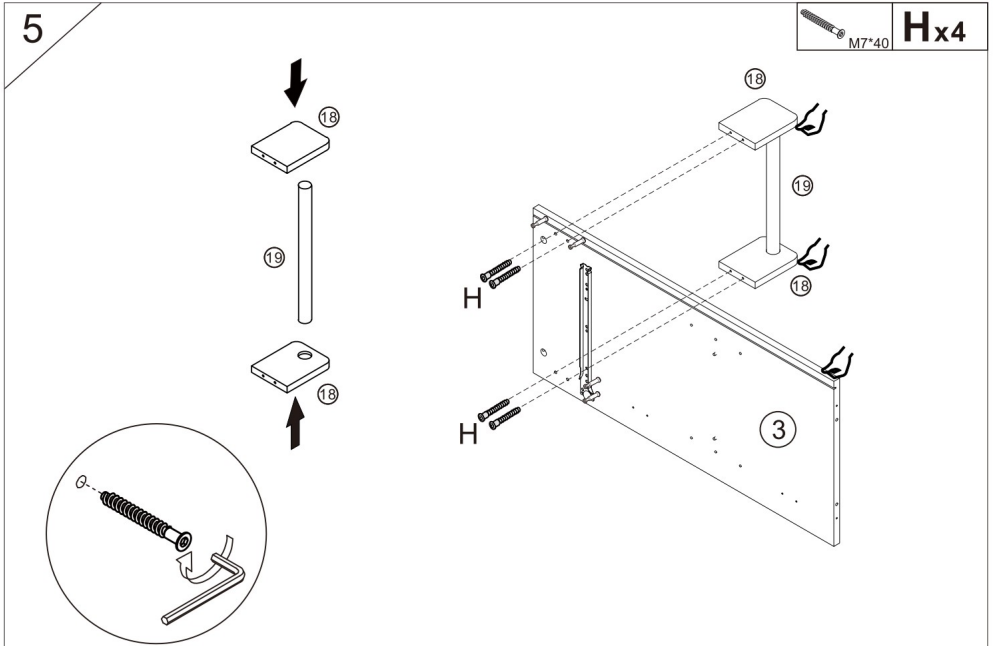

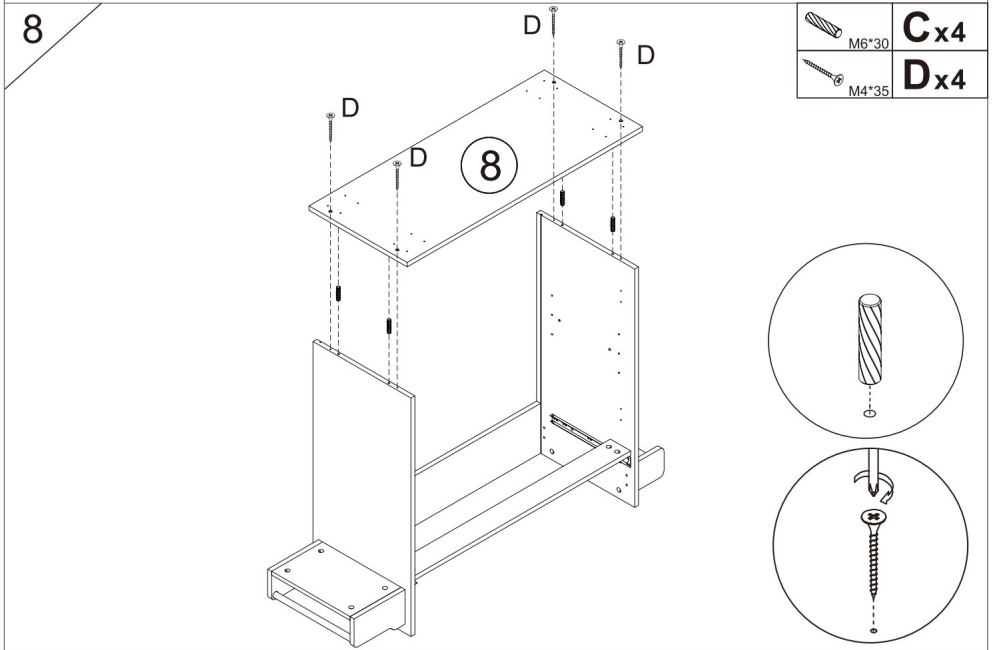
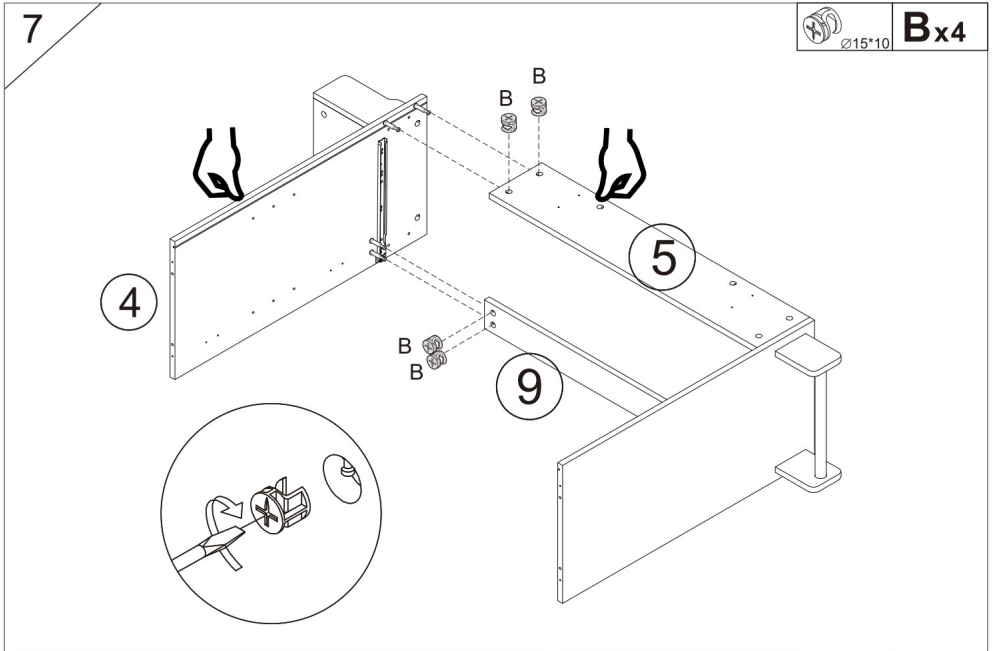

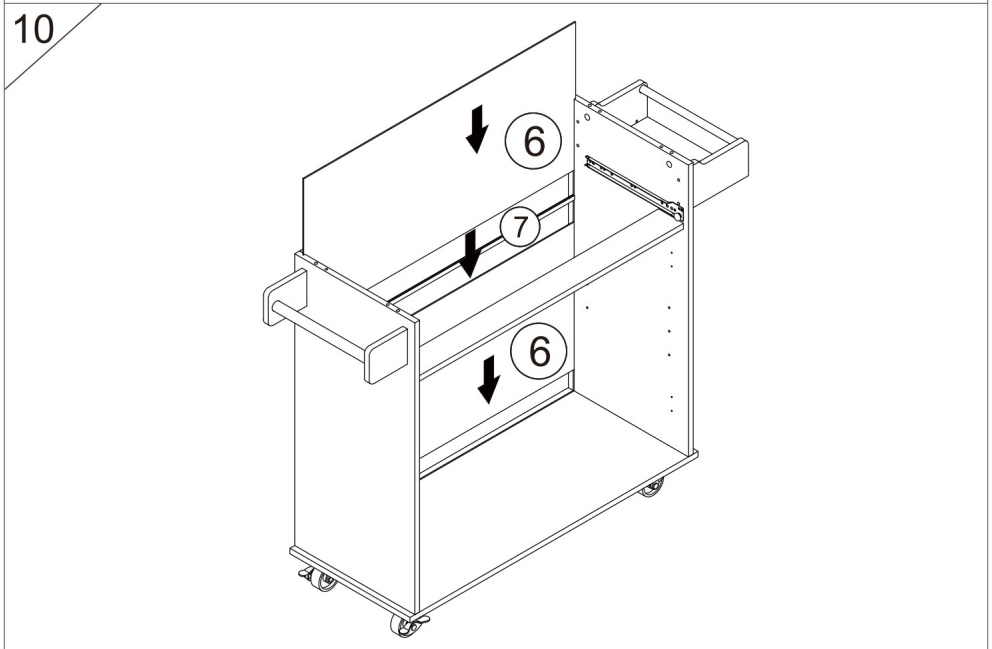
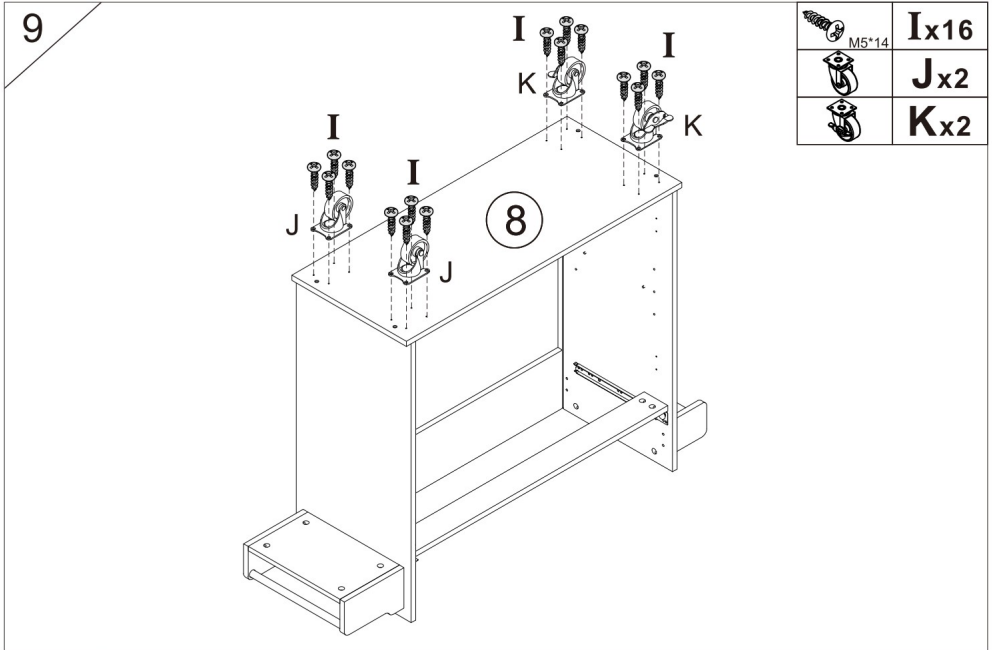

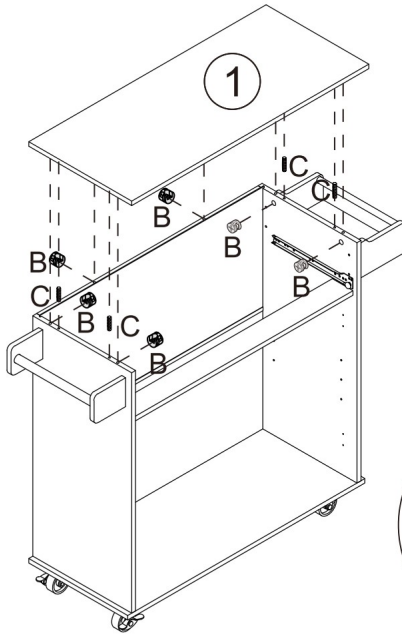

11



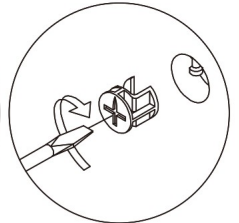
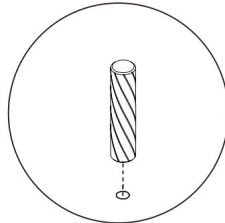

 Ø15*10	Bx6
 M6*30	Cx4

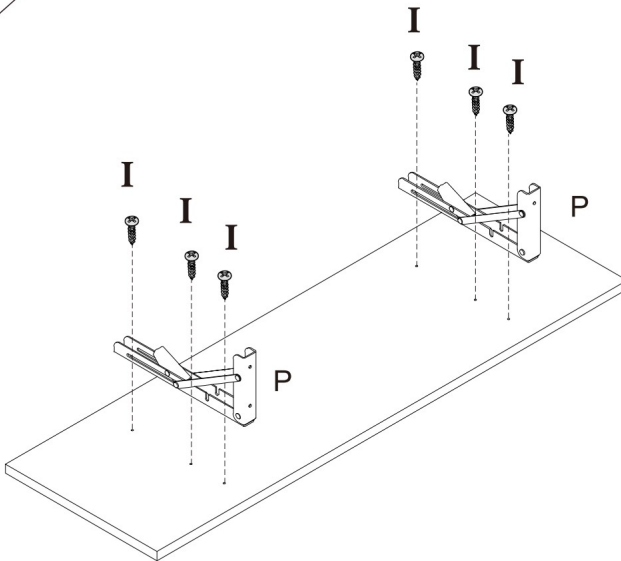

12



 M5*14	Ix6
	Px2

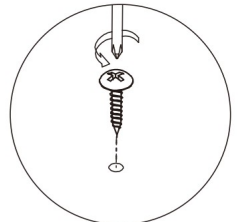
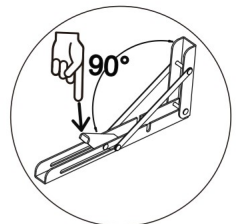

13

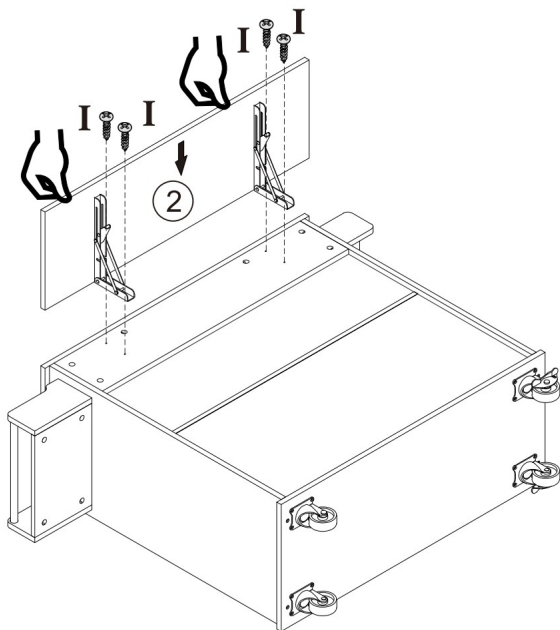

M5*14 I x4

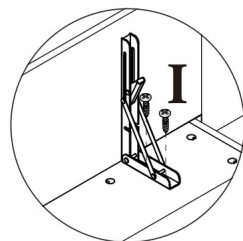
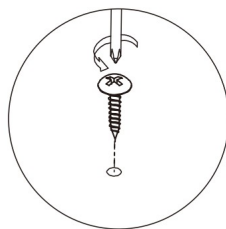

14

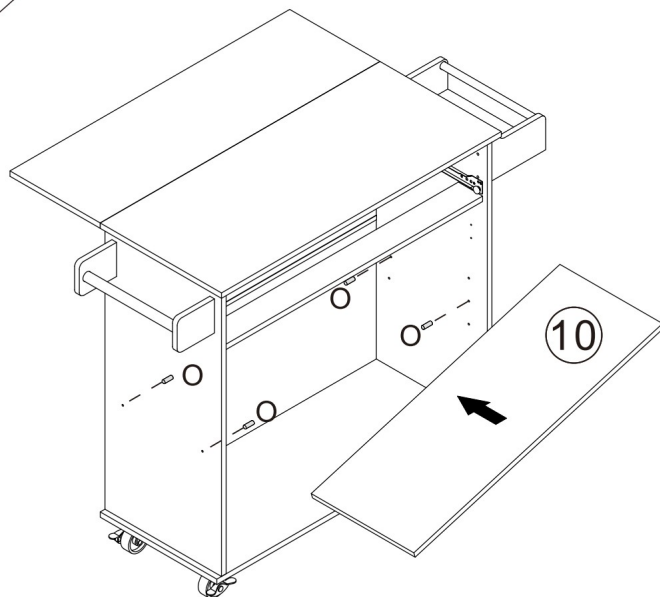

O x4

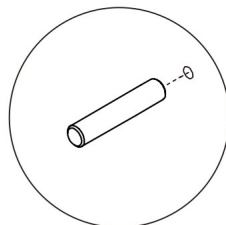



15

x2

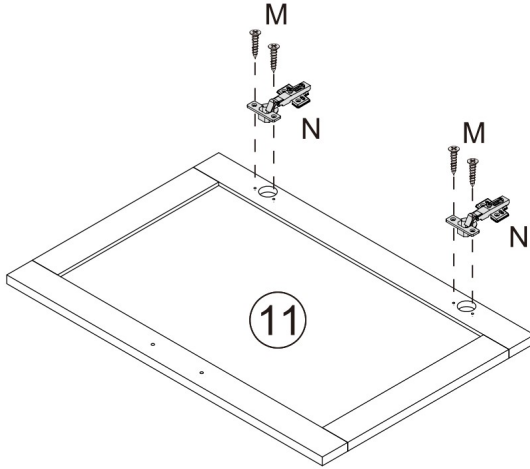
 M4*14	Mx8
	Nx4



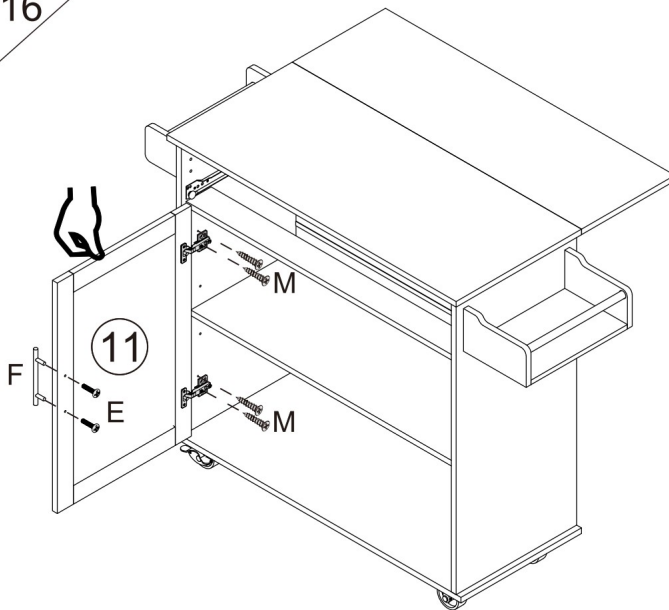

16

 M4*20	Ex2
	Fx1
 M4*14	Mx4



17

 M4*20	E x2
	F x1
 M4*14	M x4

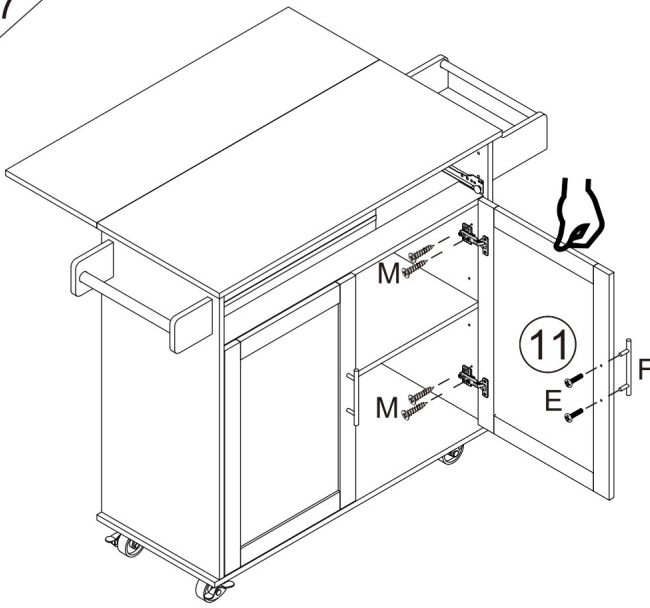

18

 M4*14	M x8
---	-------------

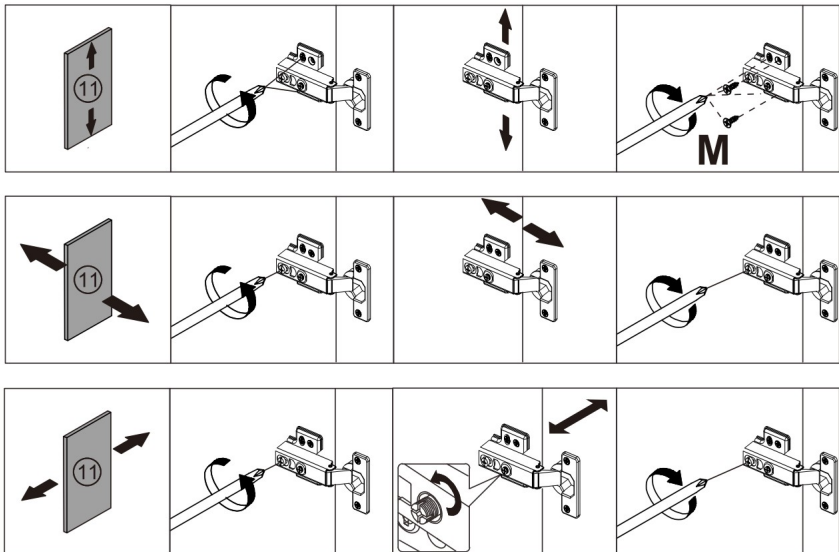





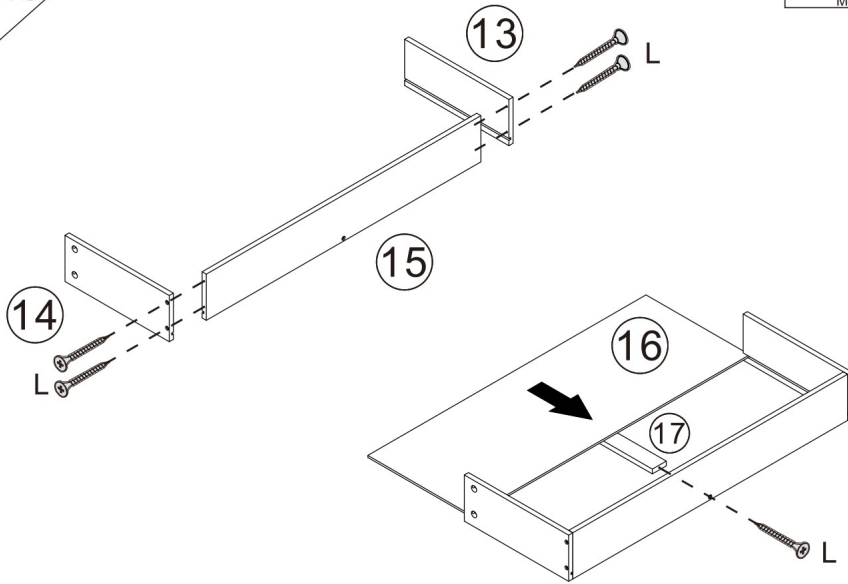

19

M4*30 **Lx5**



20

 $\varnothing 15 \times 10$	Bx5
 M4*20	Ex2
	Fx1
	DLx1
	DRx1
 M3*12	Gx4

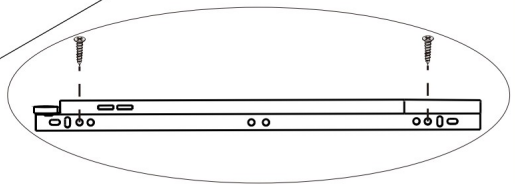
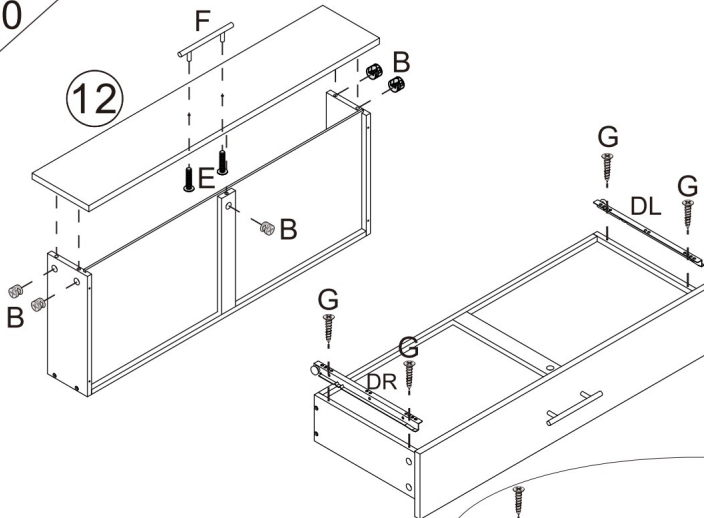

21

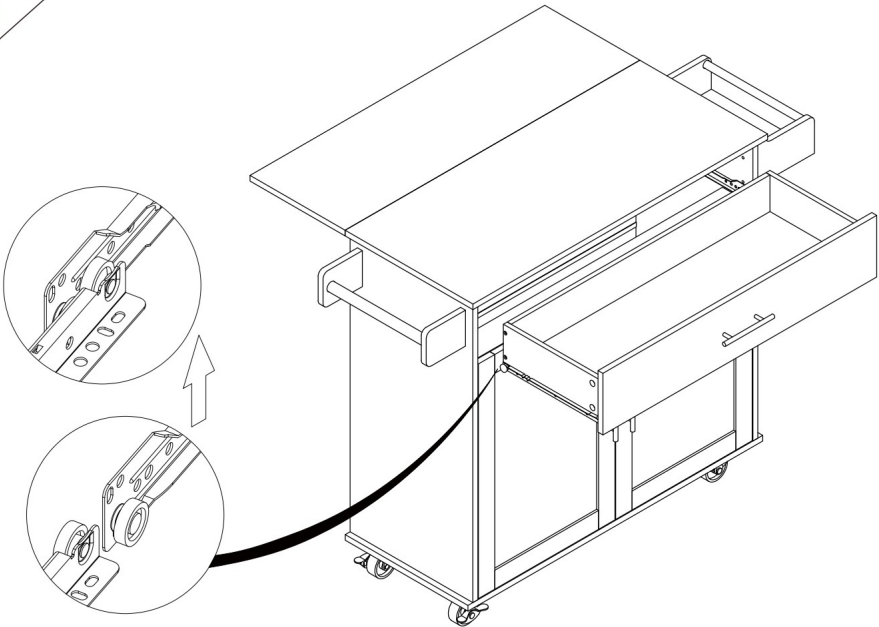

22

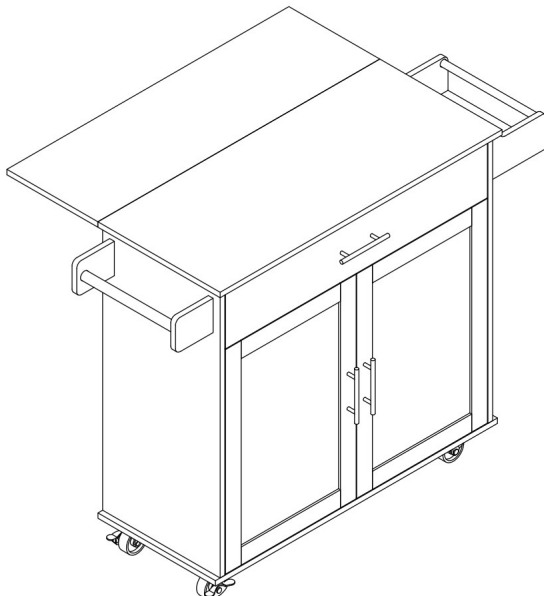

General Care

1. Make sure each layer should not exceed 40lb loading weight.
2. Make sure Folding board should not exceed 37lb loading weight.

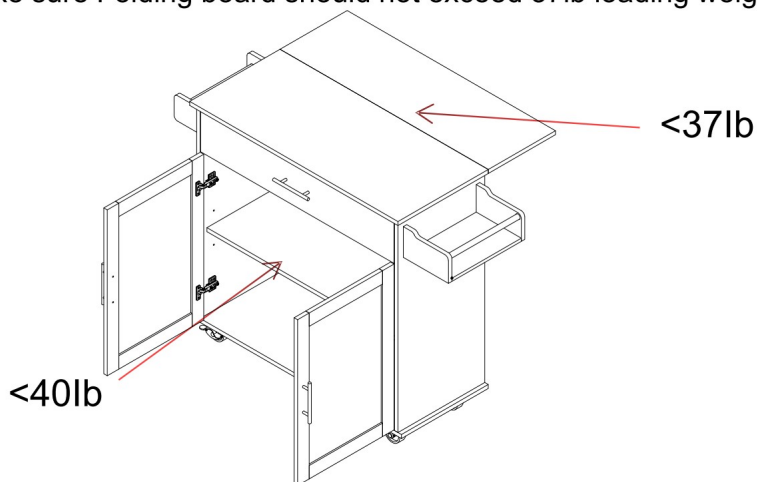

3. Make sure each drawer should not exceed 28lb loading weight.

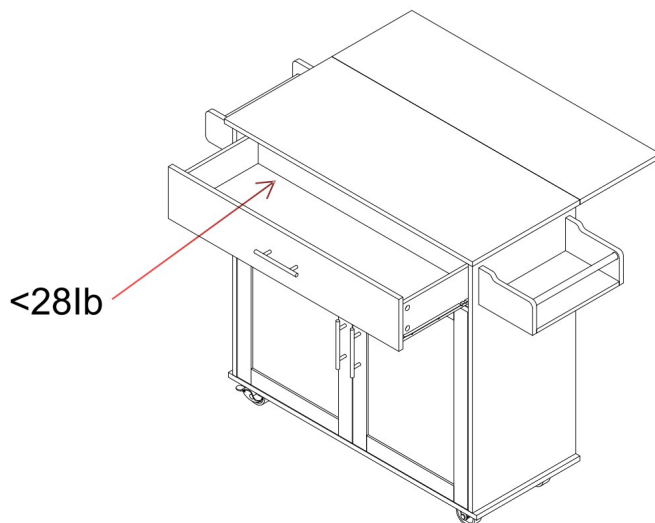

Cleaning

-For cleaning, wipe the surface with a damp (not wet) cloth or wipe dry with a clean lint free cotton cloth.

Producent: Shanghaimuxinmuyeyouxiangongsi

Adres: Shuangchenglu 803nong11hao1602A-1609shi, baoshanqu, szanghaj 200000 CN.

Importowane do AUS: SIHAO PTY LTD. 1 ROKEVA STREETEASTWOOD NSW 2122 Australia

Importowane do USA: Sanven Technology Ltd. Suite 250, 9166 Anaheim Place, Rancho Cucamonga, CA 91730



E-CrossStu GmbH
Mainzer Landstr.69, 60329 Frankfurt nad Menem.



YH CONSULTING LIMITED.
C/O YH Consulting Limited Biuro 147, Centurion House,
London Road, Staines-upon-Thames, Surrey, TW18 4AX

VEVOR[®]

TOUGH TOOLS, HALF PRICE

Support and E-Warranty Certificate <https://www.vevor.com/support>

VEVOR[®]

TOUGH TOOLS, HALF PRICE

Technical Support and E-Warranty Certificate www.vevor.com/support

KITCHEN ISLAND USER MANUAL

MODEL:SR221264

We continue to be committed to provide you tools with competitive price.

"Save Half", "Half Price" or any other similar expressions used by us only represents an estimate of savings you might benefit from buying certain tools with us compared to the major top brands and do not necessarily mean to cover all categories of tools offered by us. You are kindly reminded to verify carefully when you are placing an order with us if you are actually saving half in comparison with the top major brands.

VEVOR®

TOUGH TOOLS, HALF PRICE

**KITCHEN ISLAND
(MODEL:SR221264)**

Thanks for purchasing one of our products, please read carefully the assembly instructions before the installation.

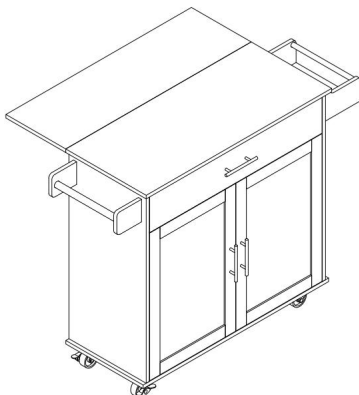

Model: SR221264

NEED HELP? CONTACT US!

Have product questions? Need technical support? Please feel free to contact us:

Technische ondersteuning en e-garantiecertificaat www.vevor.com/support

This is the original instruction, please read all manual instructions carefully before operating. VEVOR reserves a clear interpretation of our user manual. The appearance of the product shall be subject to the product you received. Please forgive us that we won't inform you again if there are any technology or software updates on our product.

PRODUCT PARAMETERS

Model	ProductSize/mm (When the folding board is opened)	Loading Capacity	Top panel size(mm)
SR221264	1190x695x905	200 lb (Max)	900x390 900x290 (Folding board)

ASSEMBLY PRECAUTIONS

1. Assemble needs to follow these instructions. Incorrect assembly can be a hazard.
2. Wear safety goggles and heavy-duty work gloves during assembly.
3. Do not assemble when tired or under the influence of alcohol, drugs or medication.
4. Weight capacity and other product capabilities only apply to a wholly and correctly assembled product.
5. Keep the assembly area clean and well-lit.
6. Keep bystanders out of the area during assembly.
7. The weight of plate is heavy; pay attention to the installation to avoid hurting it, and if necessary, find someone to assist with the installation.

Het monteren van deze kar duurt ongeveer 2 uur. Het wordt aanbevolen dat 2 personen de kar bedienen.

USE PRECAUTIONS





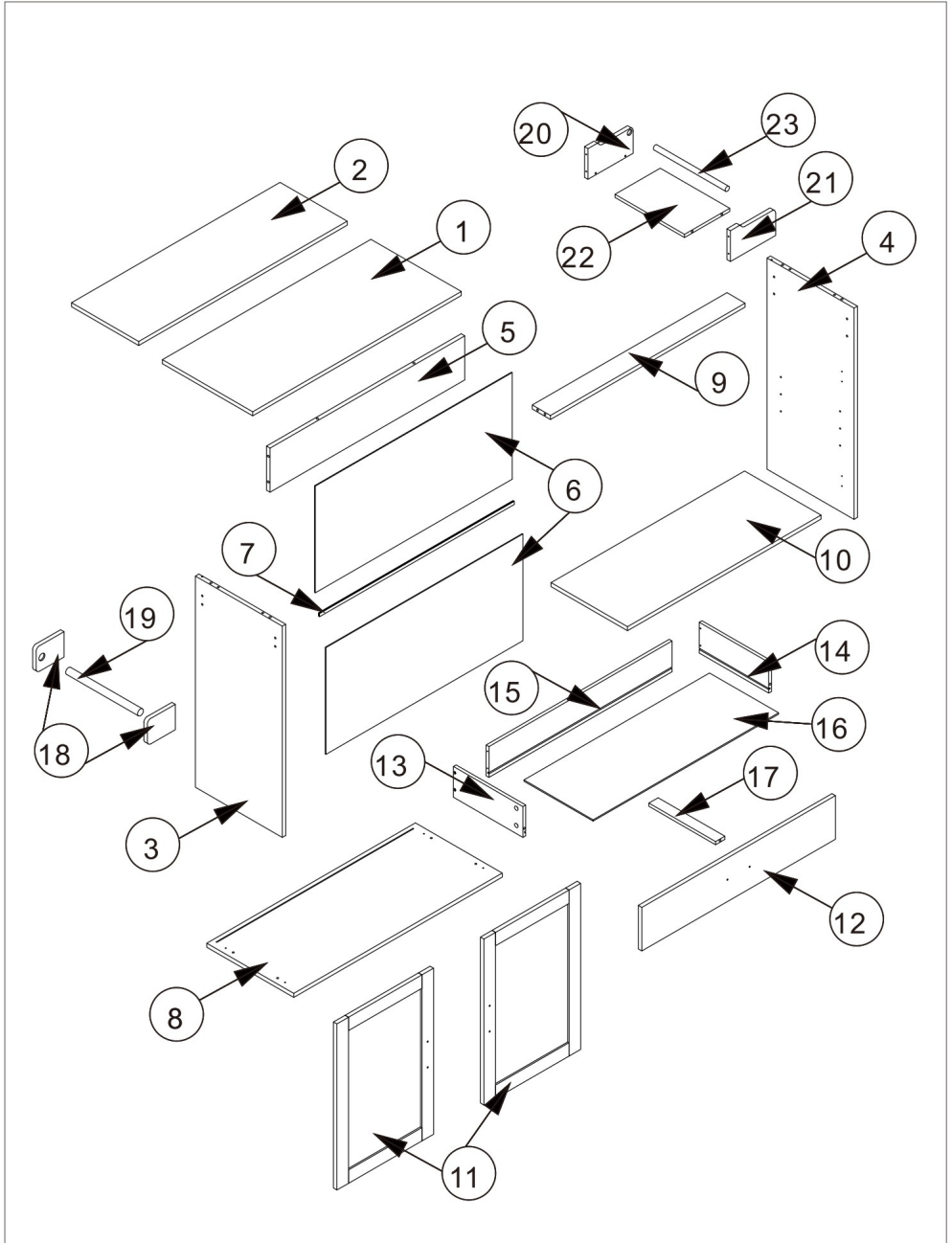

WARNING: TO PREVENT SERIOUS INJURY AND DEATH FROM TIPPING:

1. This product is not a toy. Do not allow children to play with or approach this item.
2. Use as intended only. Do not sit or stand on the product.
3. Inspect before every use. Do not use it if parts are loose or damaged.
4. Use on flat, level, and hard surfaces only.
5. Do not exceed the listed weight capacity. Tighten all knobs securely before applying load. Be aware of dynamic loading! The sudden load movement may briefly create an excess load, causing product failure.



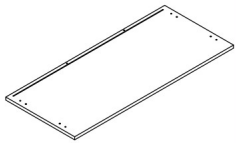
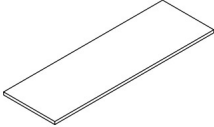
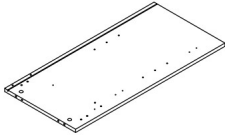
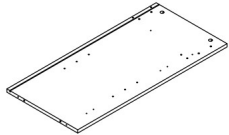
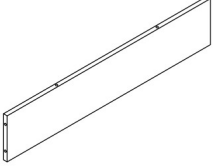
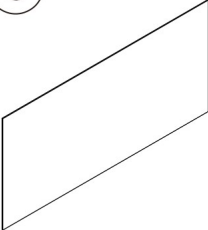

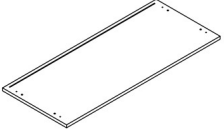
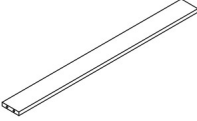
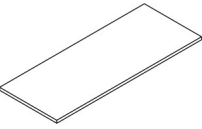
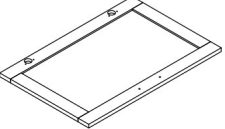
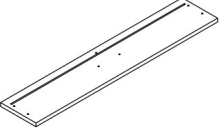

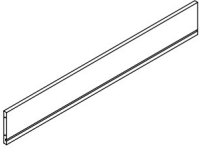
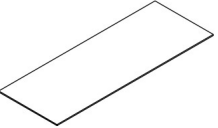

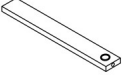
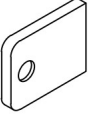
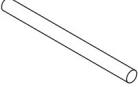
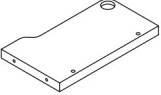
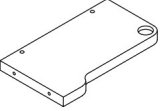
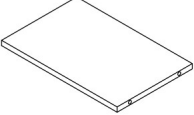
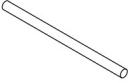











Exploded Drawing



PARTS LIST

<p>1</p>  <p>1 PC</p>	<p>2</p>  <p>1 PC</p>	<p>3</p>  <p>1 PC</p>	<p>4</p>  <p>1 PC</p>
<p>5</p>  <p>1 PC</p>	<p>6</p>  <p>2 PCS</p>	<p>7</p>  <p>1 PC</p>	<p>8</p>  <p>1 PC</p>
<p>9</p>  <p>1 PC</p>	<p>10</p>  <p>1 PC</p>	<p>11</p>  <p>2 PCS</p>	<p>12</p>  <p>1 PC</p>
<p>13</p>  <p>1 PC</p>	<p>14</p>  <p>1 PC</p>	<p>15</p>  <p>1 PC</p>	<p>16</p>  <p>1 PC</p>

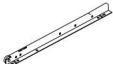
<p>17</p>  <p>1 PC</p>	<p>18</p>  <p>2 PCS</p>	<p>19</p>  <p>1 PC</p>	<p>20</p>  <p>1 PC</p>
<p>21</p>  <p>1 PC</p>	<p>22</p>  <p>1 PC</p>	<p>23</p>  <p>1 PC</p>	

A M6*35  23 PCS +1reserve	B Ø15*10  23 PCS +1reserve	C Ø6*30  8 PCS	D M4*35  4 PCS	E M4*20  6 PCS	F  3 PCS	G M3*12  8 PCS	H M7*40  8 PCS
I M5*14  26 PCS +1reserve	J  2 PCS	K  2 PCS	L M4*30  5 PCS	M M4*14  24 PCS +1reserve	N  4 PCS	O  4 PCS	P  2 PCS
Q  1 PC	CL  1 PC	CR  1 PC	DL  1 PC	DR  1 PC			

Cam Lock Fastening System

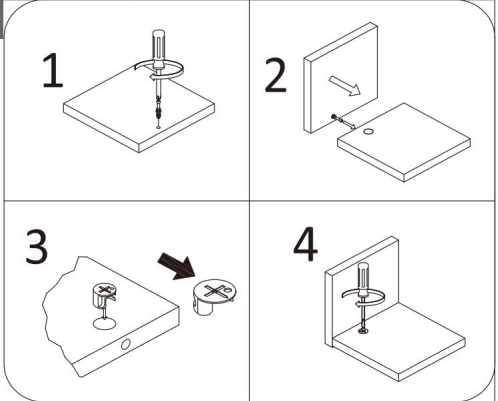
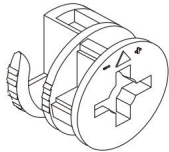

This Cam Lock Fastening System will be used throughout the assembly process

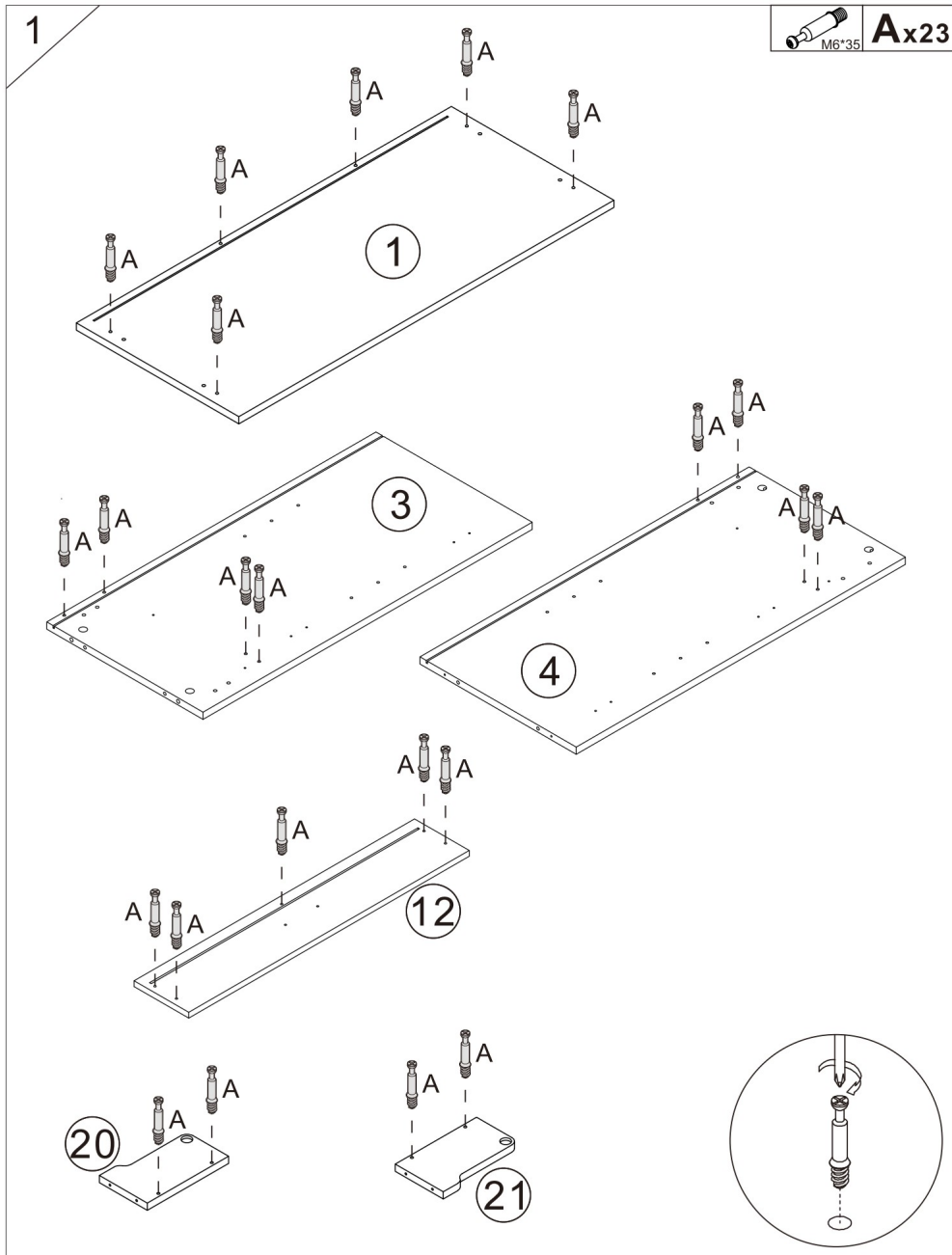

ASSEMBLY STEPS



2

	CLx1
	CRx1
	Gx4

M3*12

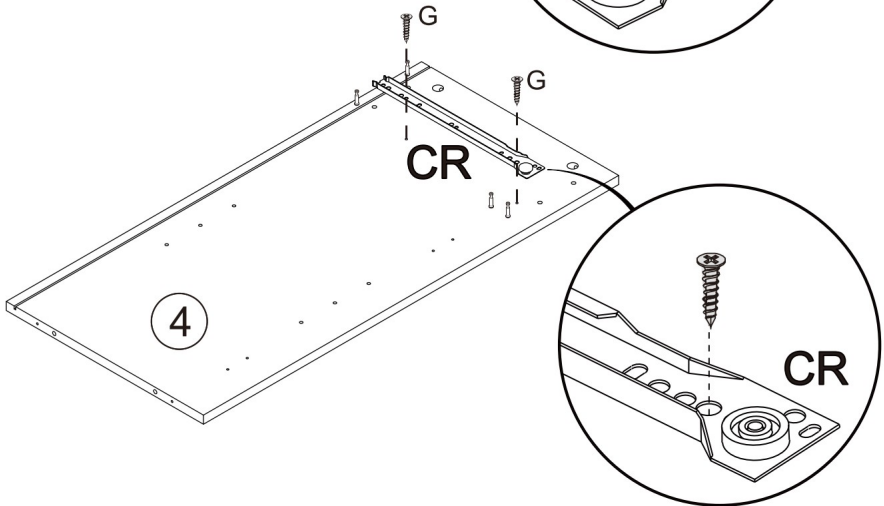
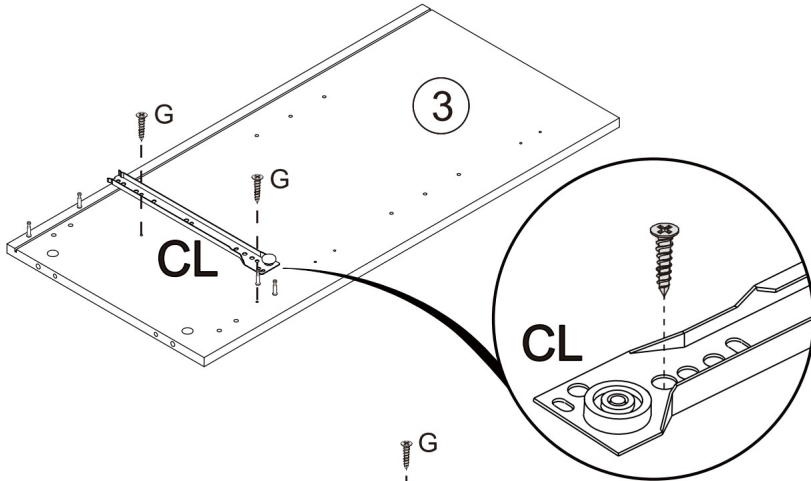

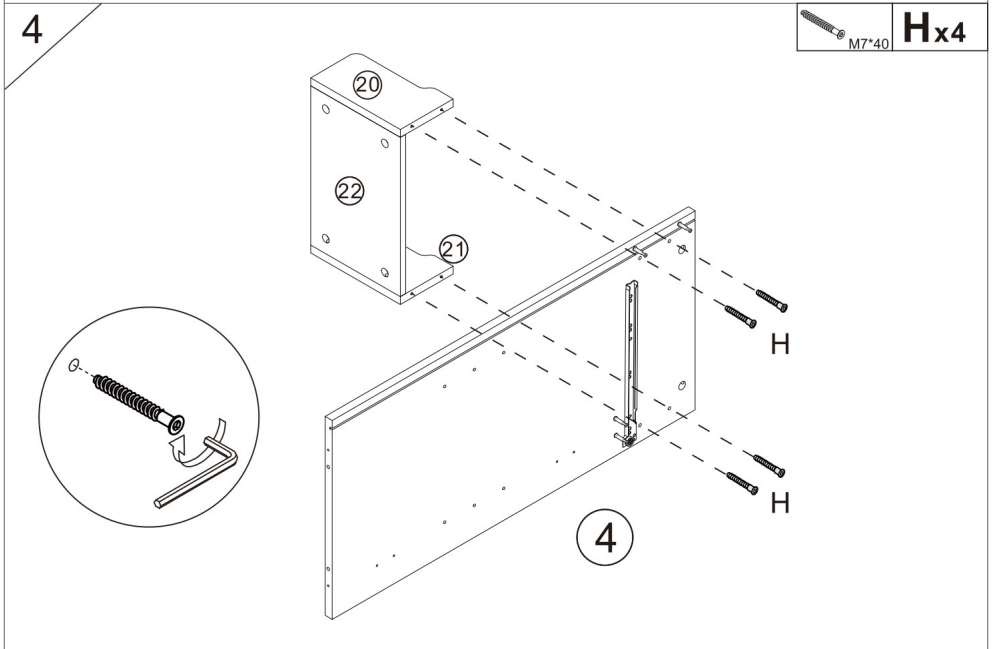
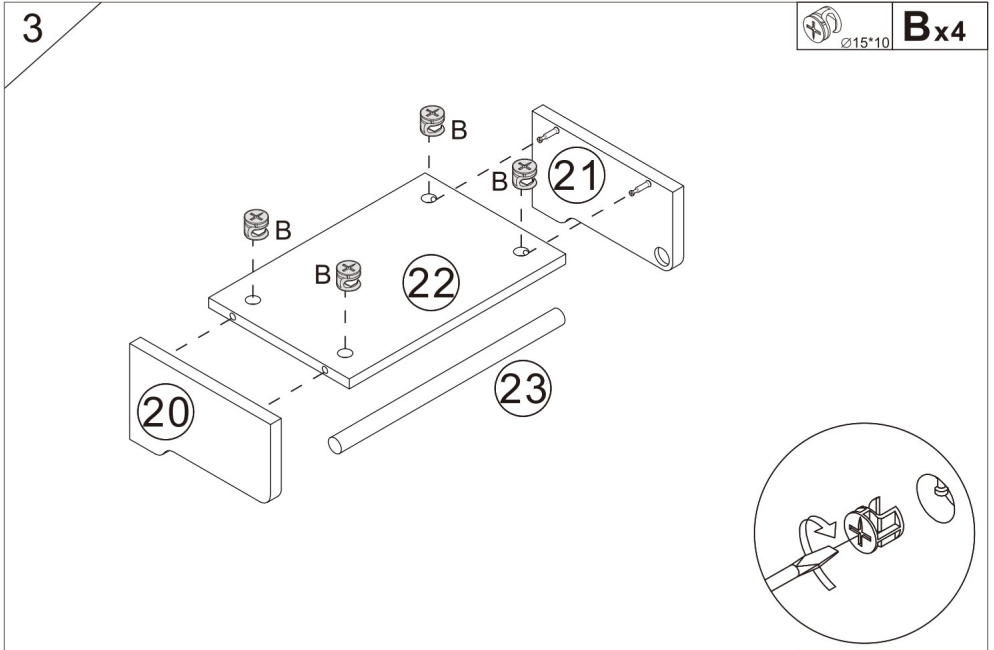

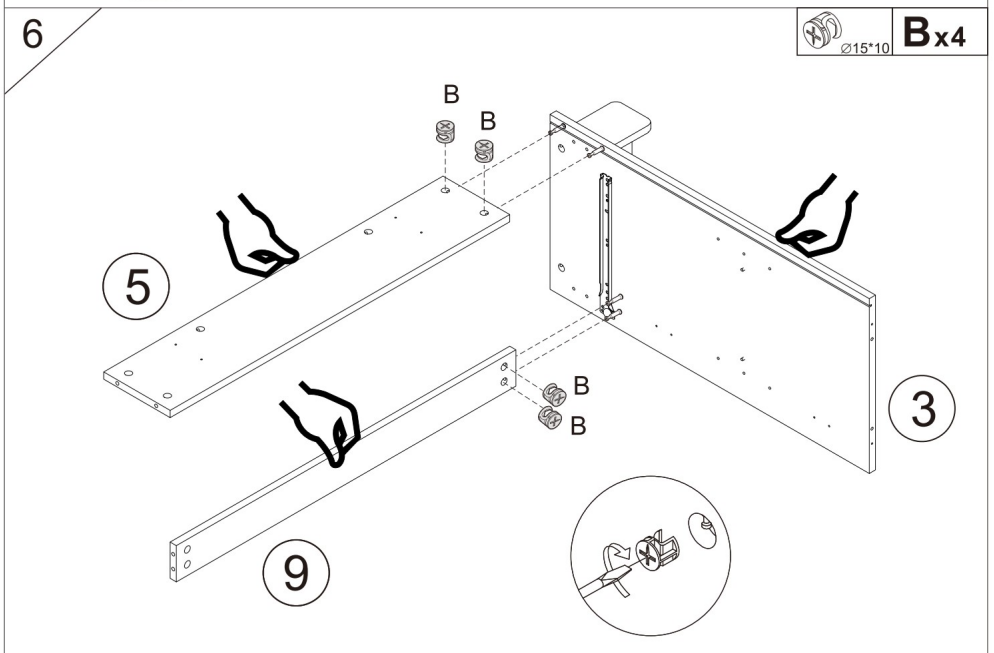
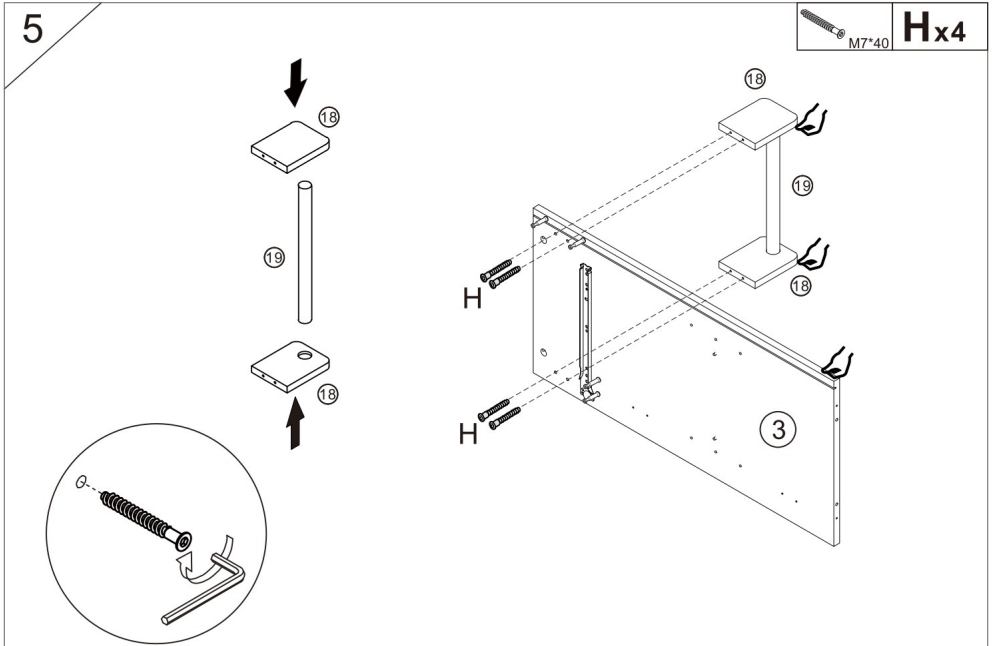

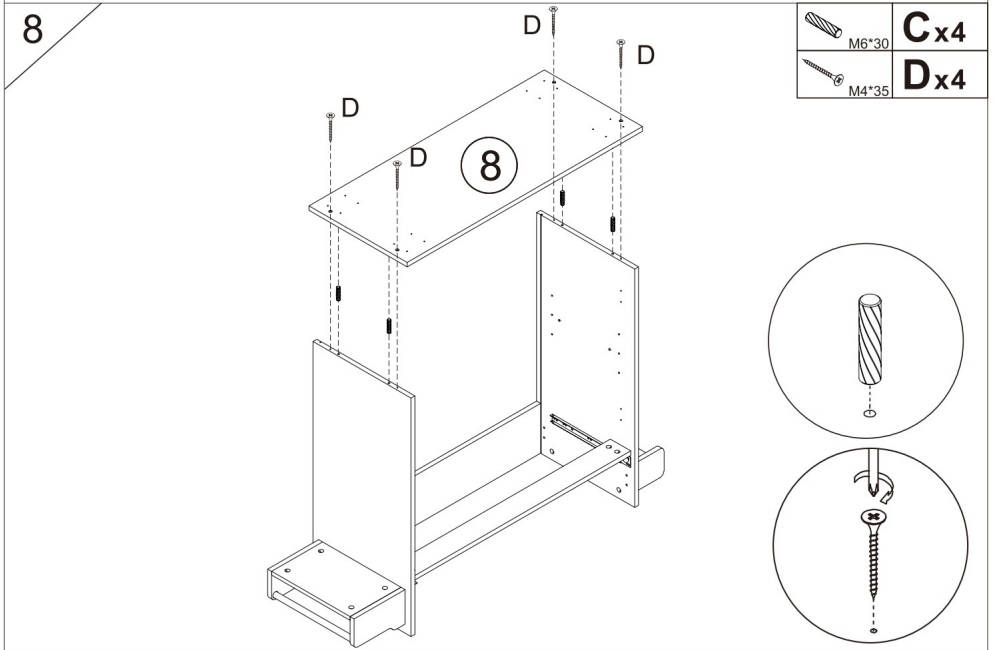
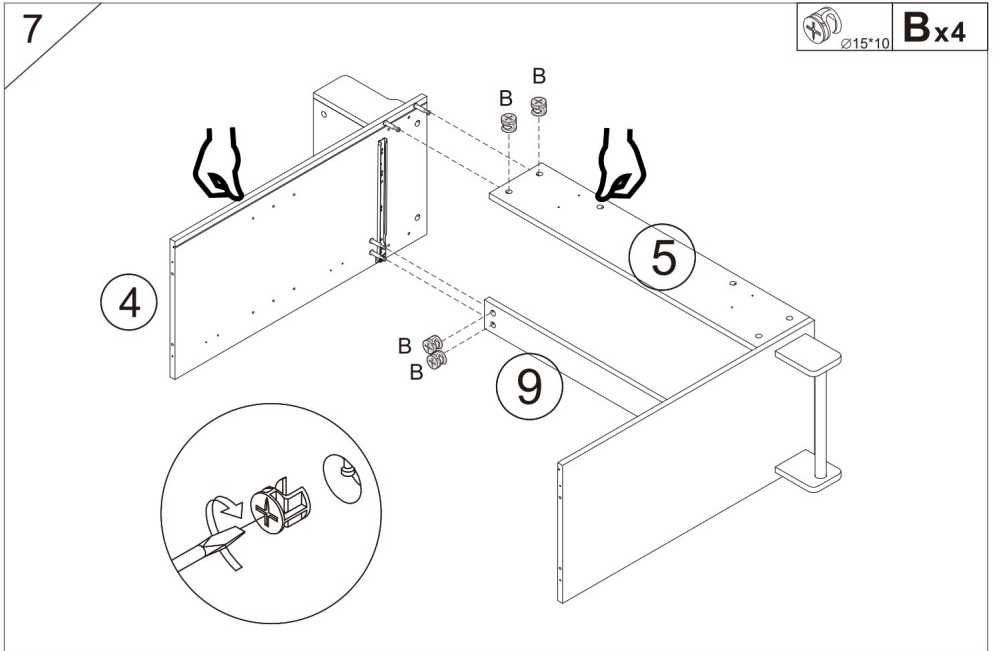

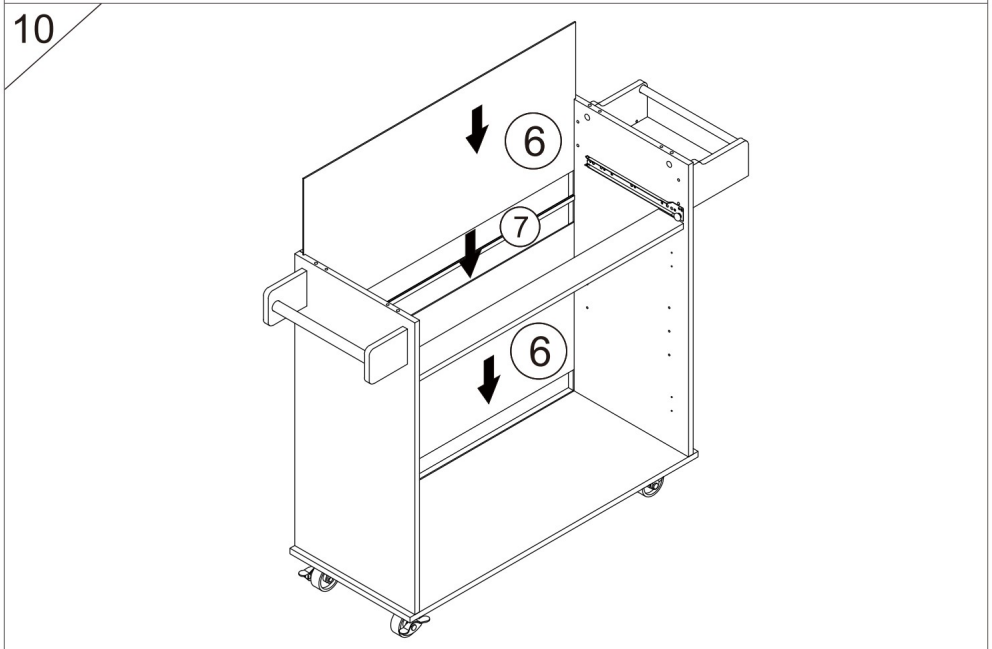
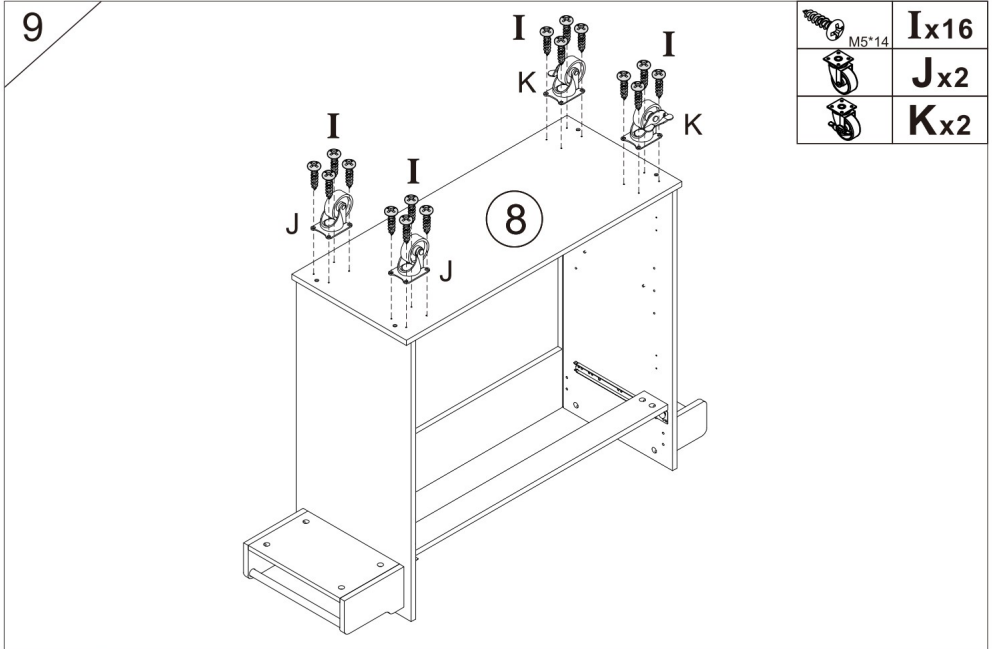

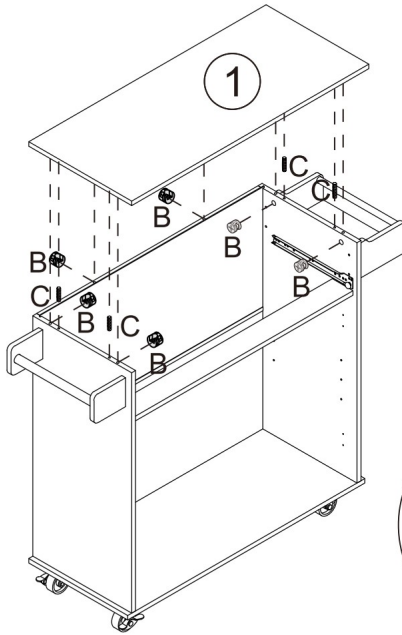

11



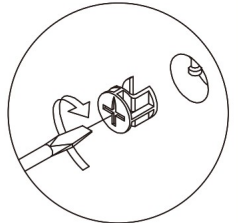
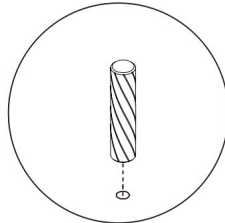

 $\varnothing 15 \times 10$	B x6
 M6 x 30	C x4

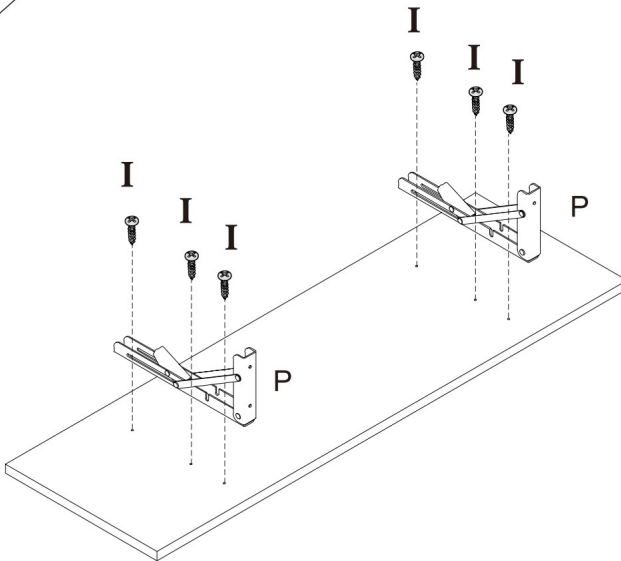

12



 M5 x 14	I x6
	P x2

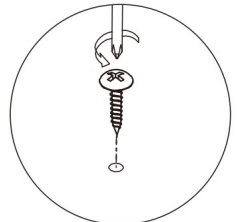
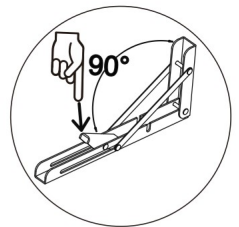

13

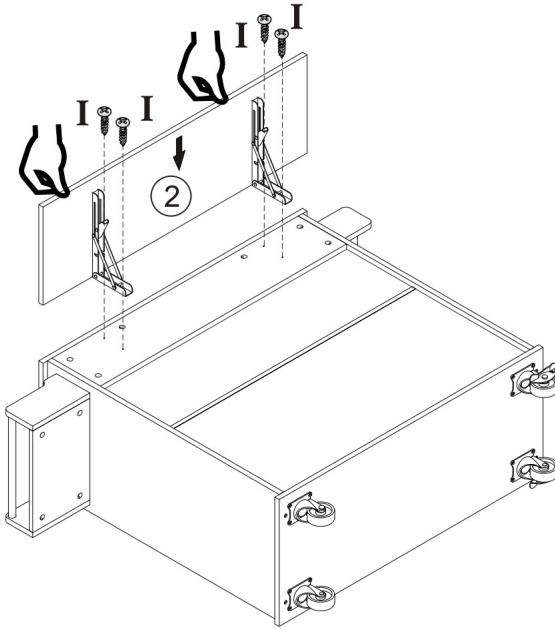

M5*14 **I**x4

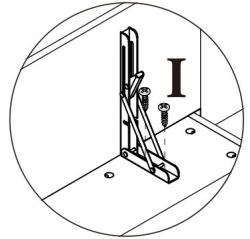
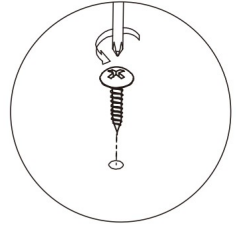

14

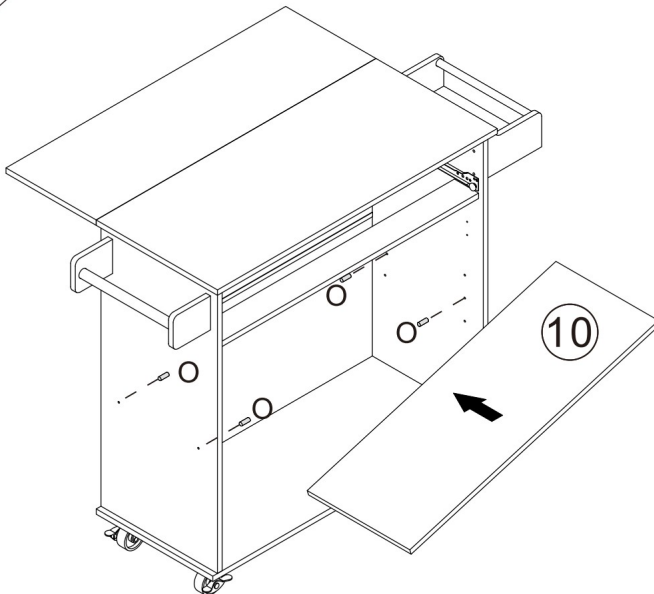

Ox4

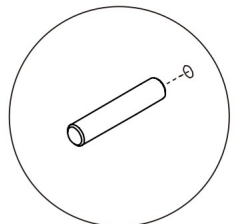



15

x2

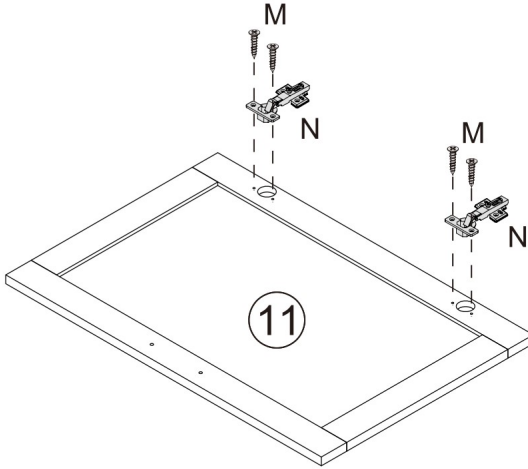
 M4*14	Mx8
	Nx4



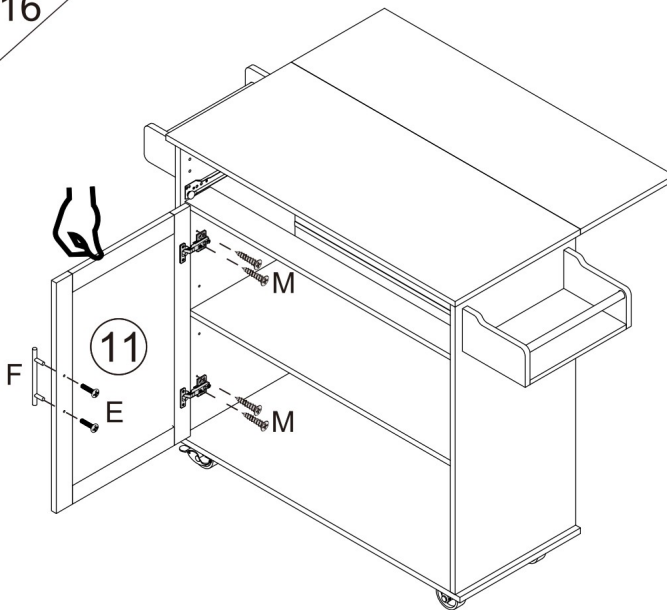

16

 M4*20	Ex2
	Fx1
 M4*14	Mx4



17

 M4*20	E x2
	F x1
 M4*14	M x4

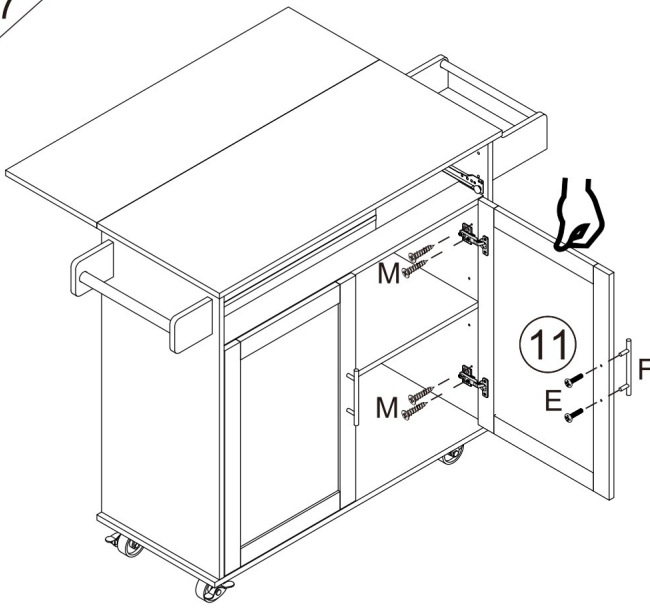

18

 M4*14	M x8
---	-------------

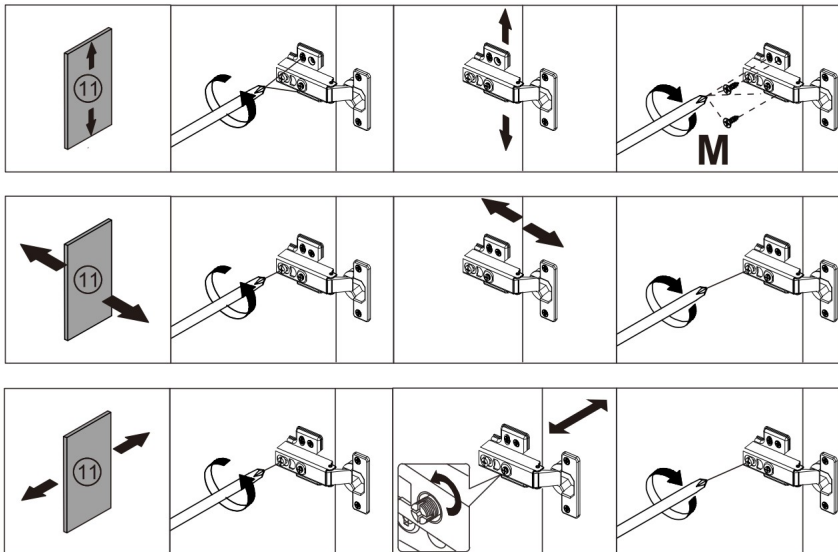

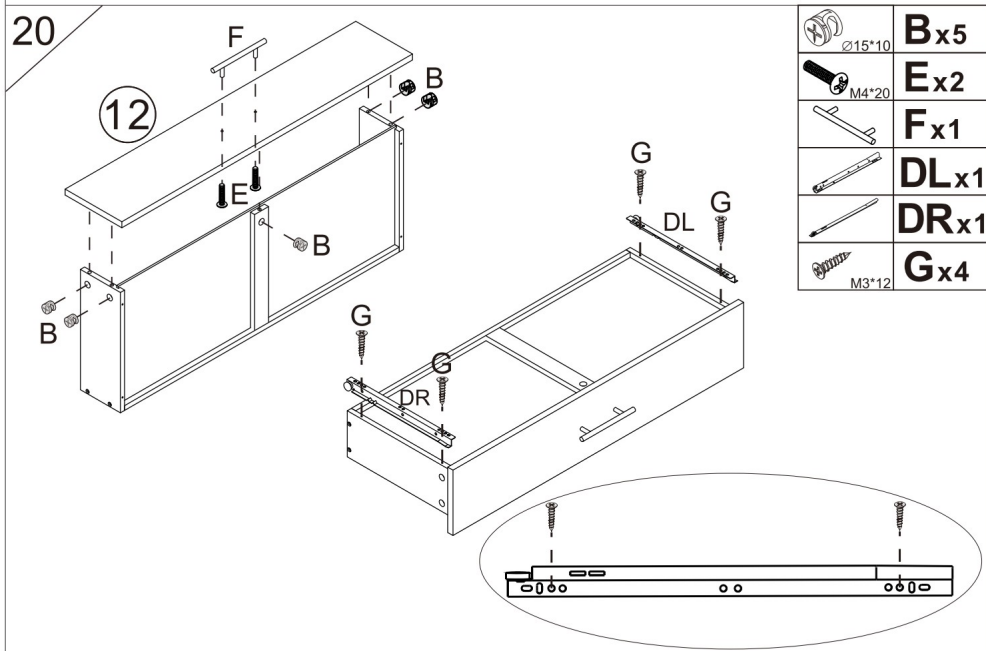
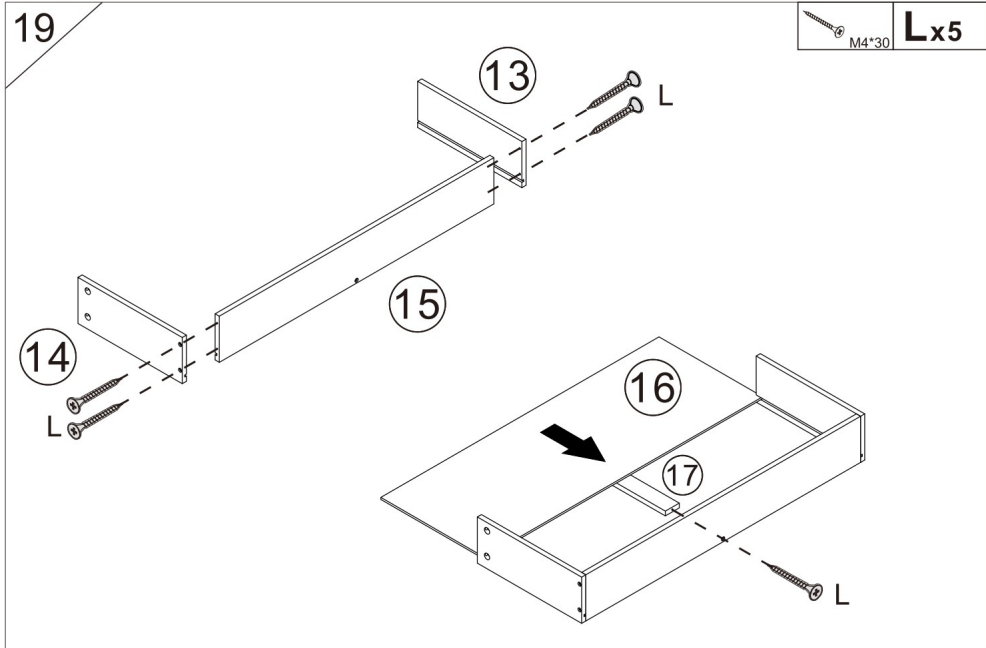

21

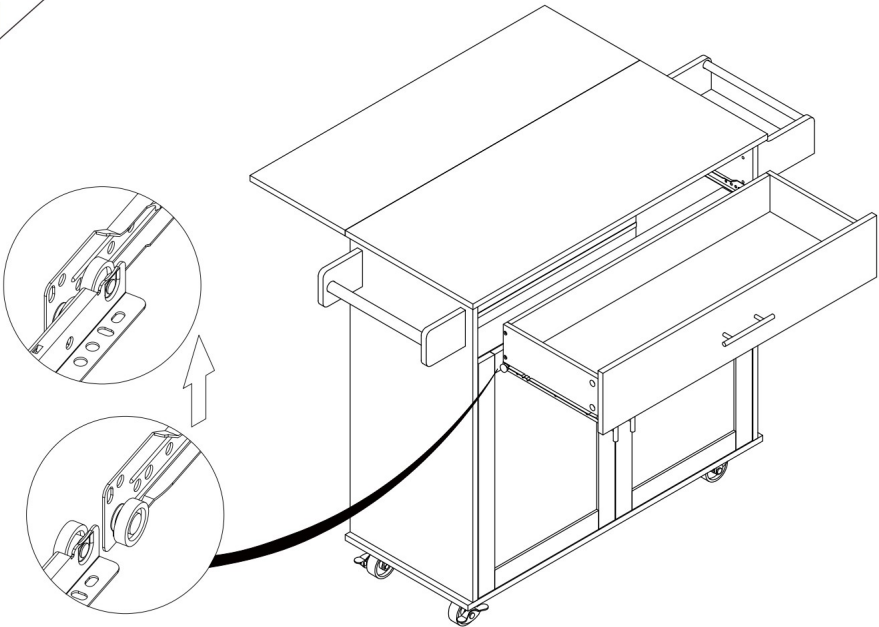

22

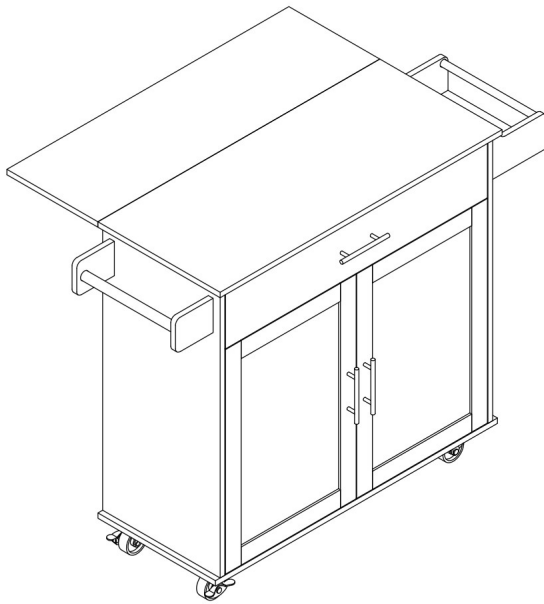

General Care

1. Make sure each layer should not exceed 40lb loading weight.
2. Make sure Folding board should not exceed 37lb loading weight.

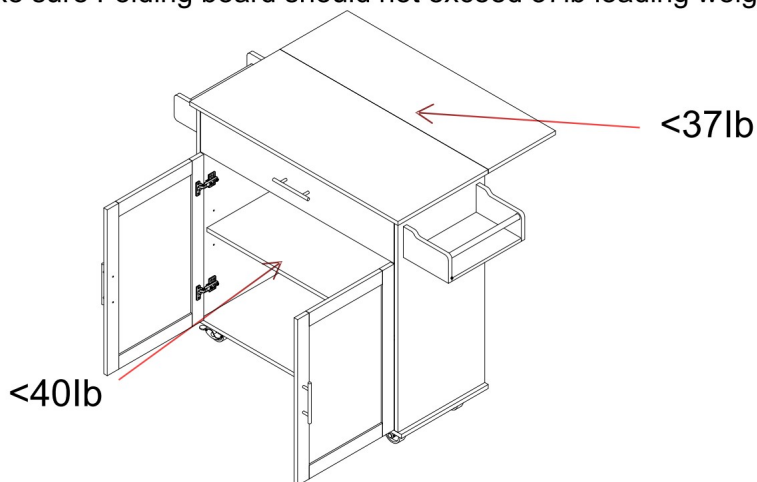

3. Make sure each drawer should not exceed 28lb loading weight.

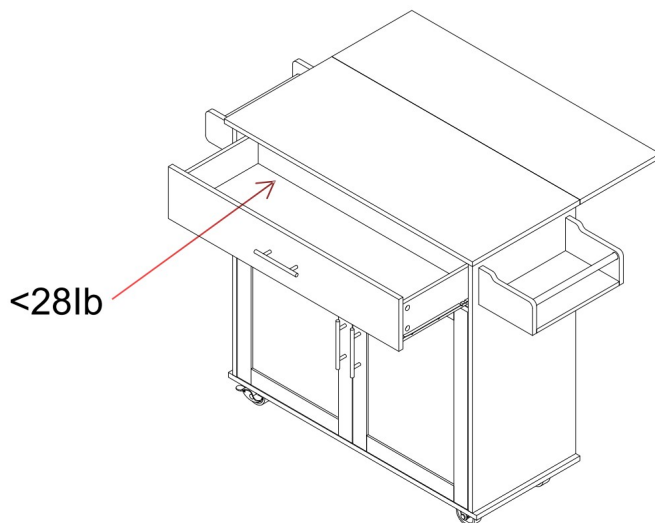

Cleaning

-For cleaning, wipe the surface with a damp (not wet) cloth or wipe dry with a clean lint free cotton cloth.

Fabrikant: Shanghaimuxinmuyeyouxiangongsi

Adres: Shuangchenglu 803nong11hao1602A-1609shi, baoshanqu, shanghai
200000 CN.

Geïmporteerd naar AUS: SIHAO PTY LTD. 1 ROKEVA STREETEASTWOOD
NSW 2122 Australië

Geïmporteerd naar de VS: Sanven Technology Ltd. Suite 250, 9166 Anaheim
Place, Rancho Cucamonga, CA 91730



E-CrossStu GmbH
Mainzer Landstr.69, 60329 Frankfurt am Main.



YH CONSULTING LIMITED.
C/O YH Consulting Limited Kantoor 147, Centurion House,
London Road, Staines-upon-Thames, Surrey, TW18 4AX

VEVOR[®]

TOUGH TOOLS, HALF PRICE

Support and E-Warranty Certificate <https://www.vevor.com/support>

VEVOR[®]

TOUGH TOOLS, HALF PRICE

Technical Support and E-Warranty Certificate www.vevor.com/support

KITCHEN ISLAND USER MANUAL

MODEL:SR221264

We continue to be committed to provide you tools with competitive price.

"Save Half", "Half Price" or any other similar expressions used by us only represents an estimate of savings you might benefit from buying certain tools with us compared to the major top brands and ^{90r} not necessarily mean to cover all categories of tools offered by us. You are kindly reminded to verify carefully when you are placing an order with us if you are actually saving half in comparison with the top major brands.

VEVOR®

TOUGH TOOLS, HALF PRICE

**KITCHEN ISLAND
(MODEL:SR221264)**

Thanks for purchasing one of our products, please read carefully the assembly instructions before the installation.

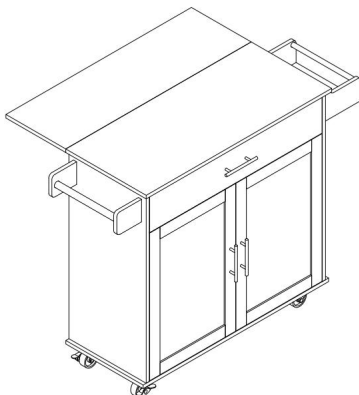

Model: SR221264

NEED HELP? CONTACT US!

Have product questions? Need technical support? Please feel free to contact us:

Teknisk support och e-garanticertifikat
www.vevor.com/support

This is the original instruction, please read all manual instructions carefully before operating. VEVOR reserves a clear interpretation of our user manual. The appearance of the product shall be subject to the product you received. Please forgive us that we won't inform you again if there are any technology or software updates on our product.

PRODUCT PARAMETERS

Model	ProductSize/mm (When the folding board is opened)	Loading Capacity	Top panel size(mm)
SR221264	1190x695x905	200 lb (Max)	900x390 900x290 (Folding board)

ASSEMBLY PRECAUTIONS

1. Assemble needs to follow these instructions. Incorrect assembly can be a hazard.
2. Wear safety goggles and heavy-duty work gloves during assembly.
3. Do not assemble when tired or under the influence of alcohol, drugs or medication.
4. Weight capacity and other product capabilities only apply to a wholly and correctly assembled product.
5. Keep the assembly area clean and well-lit.
6. Keep bystanders out of the area during assembly.
7. The weight of plate is heavy; pay attention to the installation to avoid hurting it, and if necessary, find someone to assist with the installation.

Att montera denna vagn tar cirka 2 timmar, det rekommenderas att 2 personer använder den.

USE PRECAUTIONS





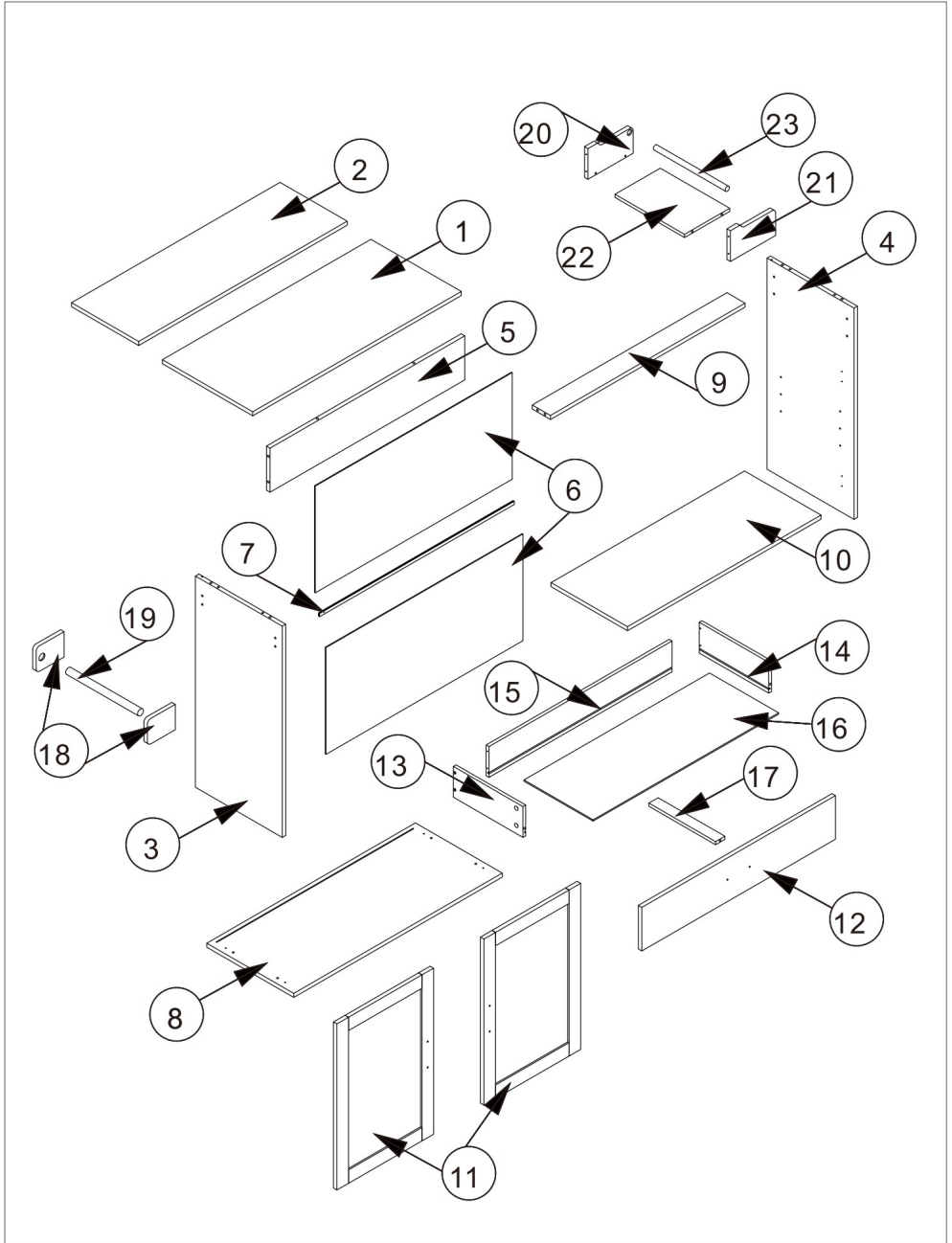

WARNING: TO PREVENT SERIOUS INJURY AND DEATH FROM TIPPING:

1. This product is not a toy. Do not allow children to play with or approach this item.
2. Use as intended only. Do not sit or stand on the product.
3. Inspect before every use. Do not use it if parts are loose or damaged.
4. Use on flat, level, and hard surfaces only.
5. Do not exceed the listed weight capacity. Tighten all knobs securely before applying load. Be aware of dynamic loading! The sudden load movement may briefly create an excess load, causing product failure.



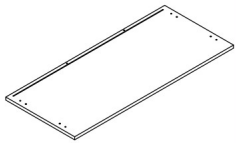
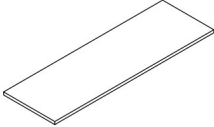
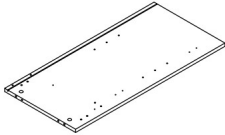
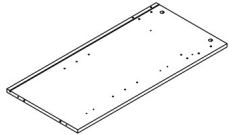
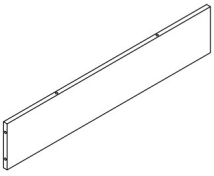
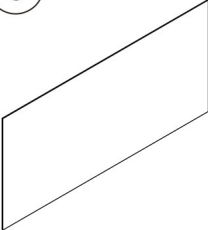

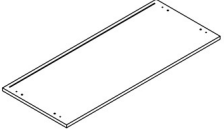
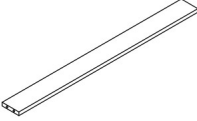
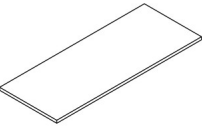
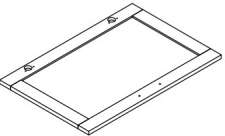
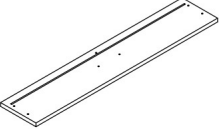

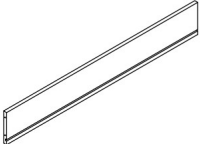
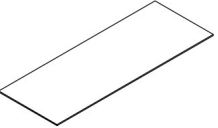

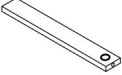
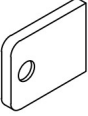
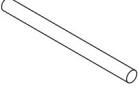
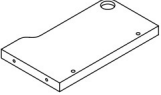
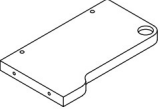
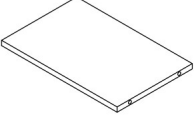
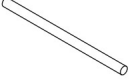











Exploded Drawing



PARTS LIST

<p>1</p>  <p>1 PC</p>	<p>2</p>  <p>1 PC</p>	<p>3</p>  <p>1 PC</p>	<p>4</p>  <p>1 PC</p>
<p>5</p>  <p>1 PC</p>	<p>6</p>  <p>2 PCS</p>	<p>7</p>  <p>1 PC</p>	<p>8</p>  <p>1 PC</p>
<p>9</p>  <p>1 PC</p>	<p>10</p>  <p>1 PC</p>	<p>11</p>  <p>2 PCS</p>	<p>12</p>  <p>1 PC</p>
<p>13</p>  <p>1 PC</p>	<p>14</p>  <p>1 PC</p>	<p>15</p>  <p>1 PC</p>	<p>16</p>  <p>1 PC</p>

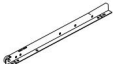
<p>17</p>  <p>1 PC</p>	<p>18</p>  <p>2 PCS</p>	<p>19</p>  <p>1 PC</p>	<p>20</p>  <p>1 PC</p>
<p>21</p>  <p>1 PC</p>	<p>22</p>  <p>1 PC</p>	<p>23</p>  <p>1 PC</p>	

A M6*35  23 PCS +1 reserv	B Ø15*10  23 PCS +1 reserv	C Ø6*30  8 PCS	D M4*35  4 PCS	E M4*20  6 PCS	F  3 PCS	G M3*12  8 PCS	H M7*40  8 PCS
I M5*14  26 PCS +1 reserv	J  2 PCS	K  2 PCS	L M4*30  5 PCS	M M4*14  24 PCS +1 reserv	N  4 PCS	O  4 PCS	P  2 PCS
Q  1 PC	CL  1 PC	CR  1 PC	DL  1 PC	DR  1 PC			

Cam Lock Fastening System

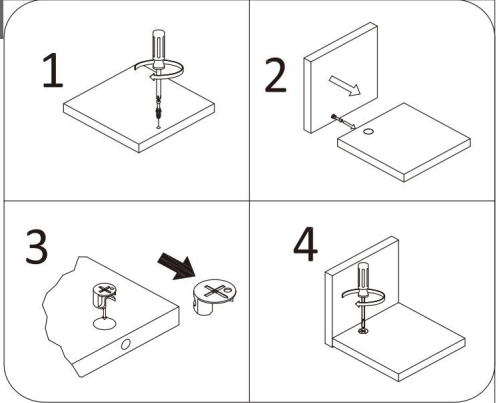
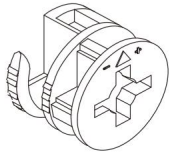

This Cam Lock Fastening System will be used throughout the assembly process

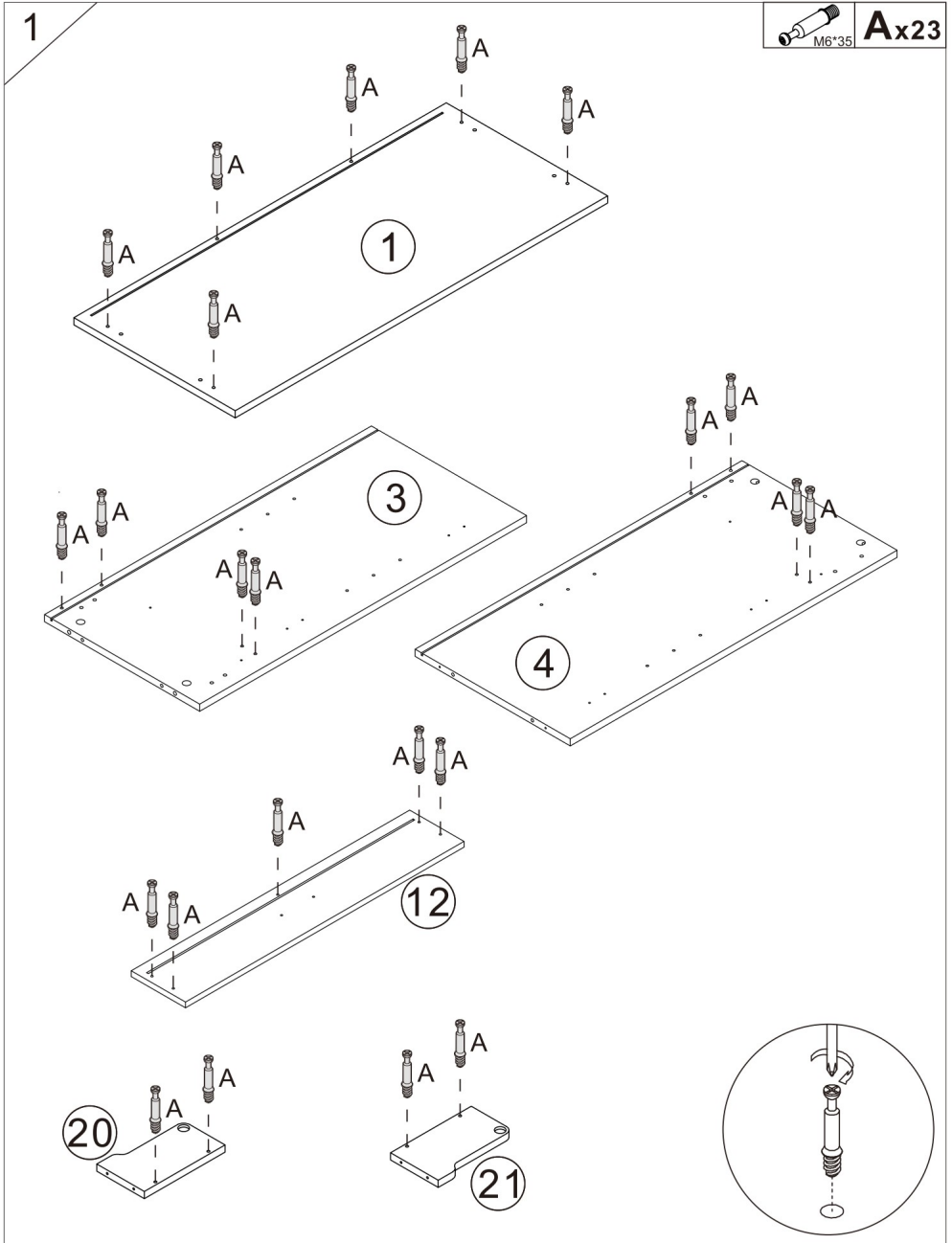

ASSEMBLY STEPS



2

	CLx1
	CRx1
 M3*12	Gx4

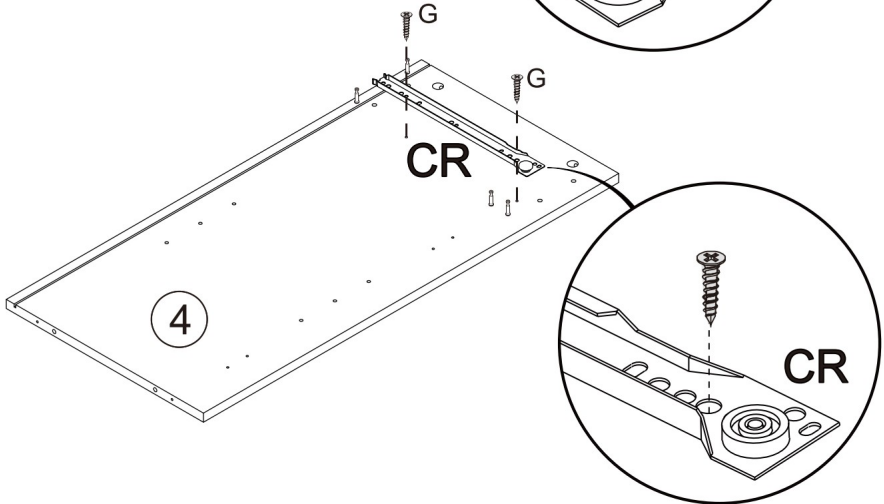
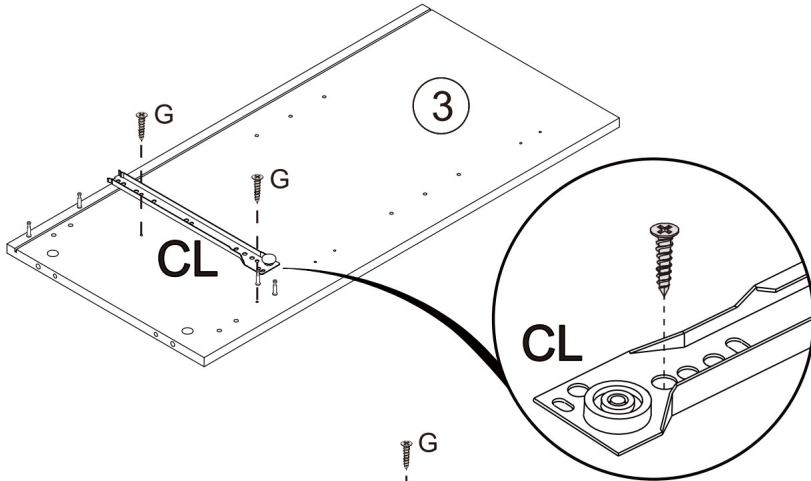

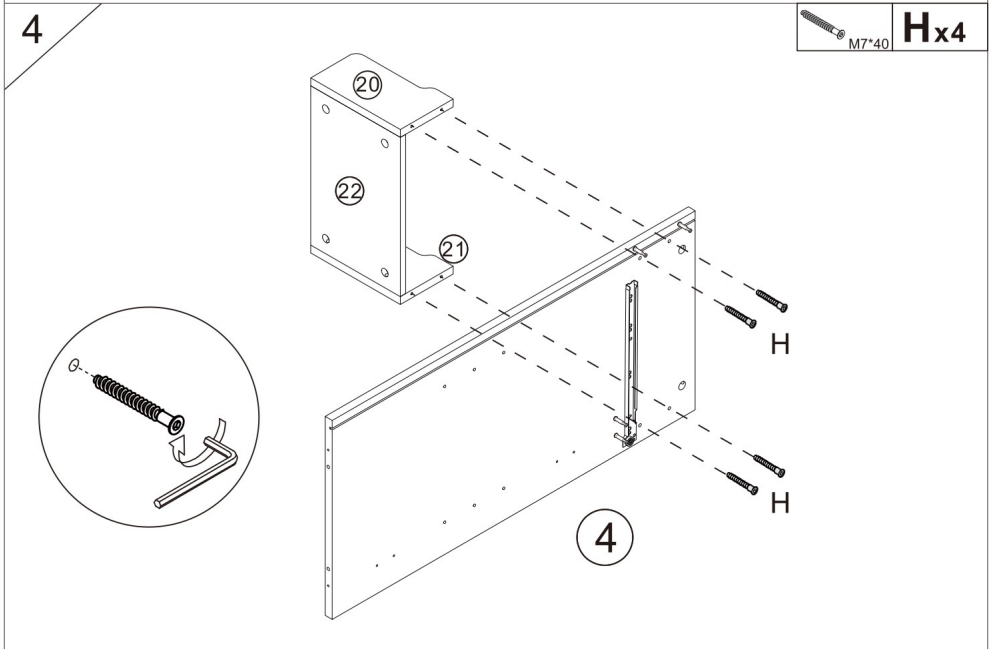
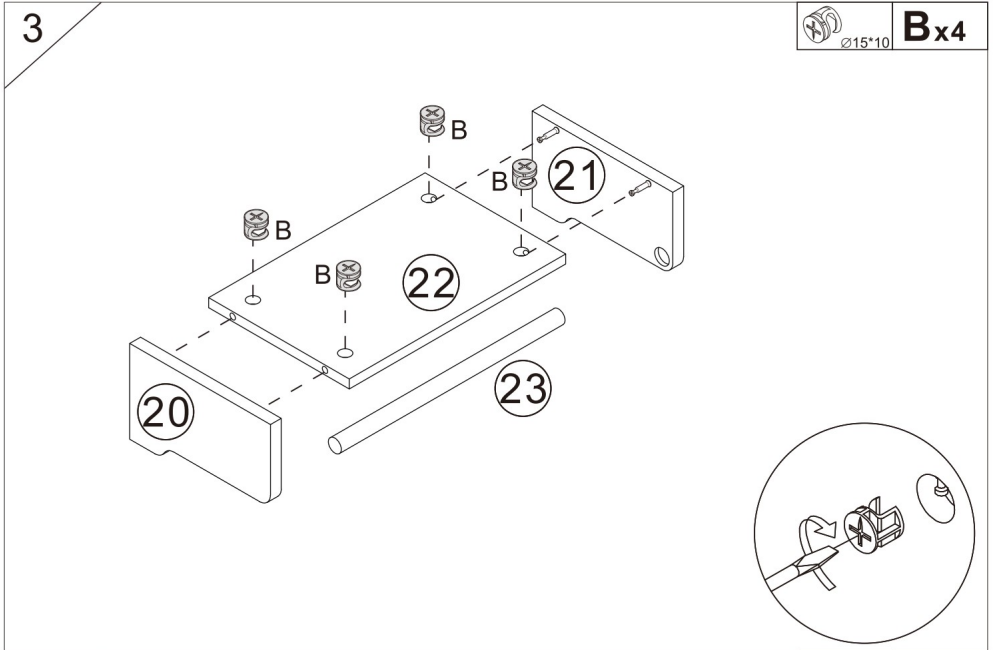

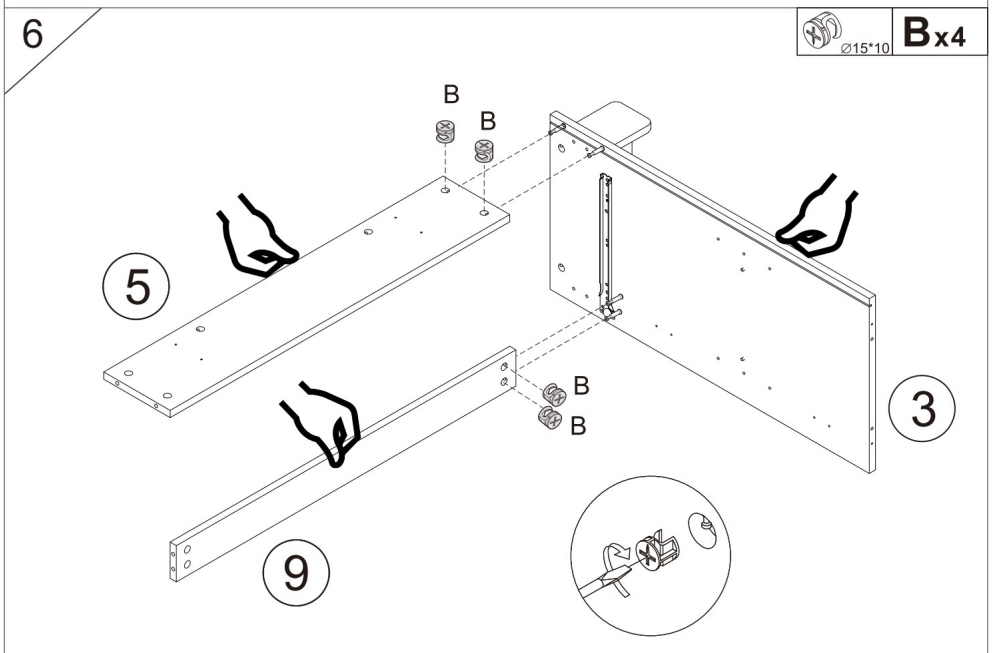
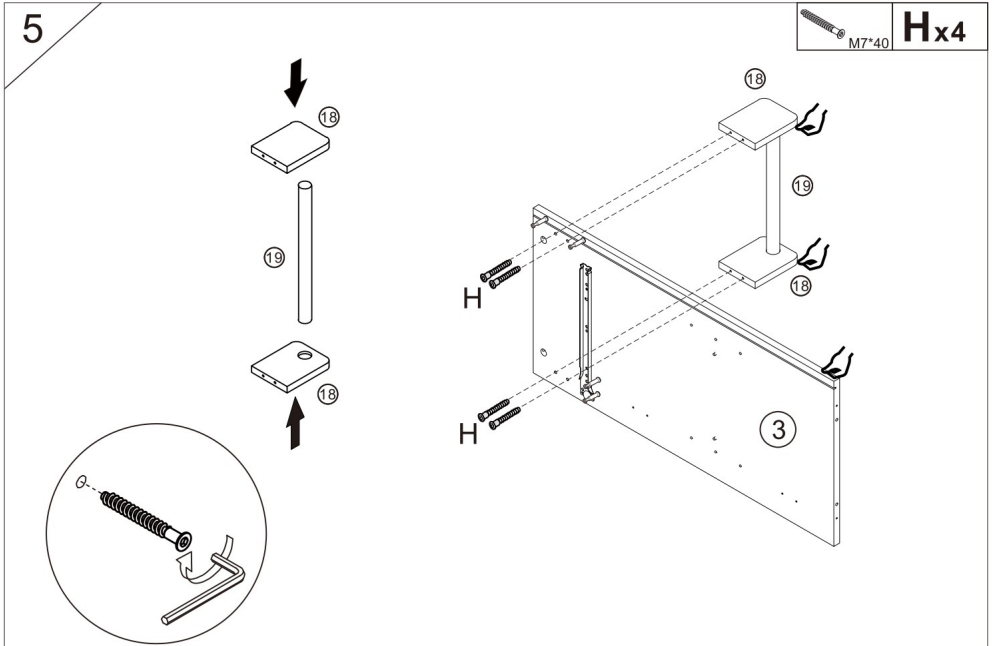

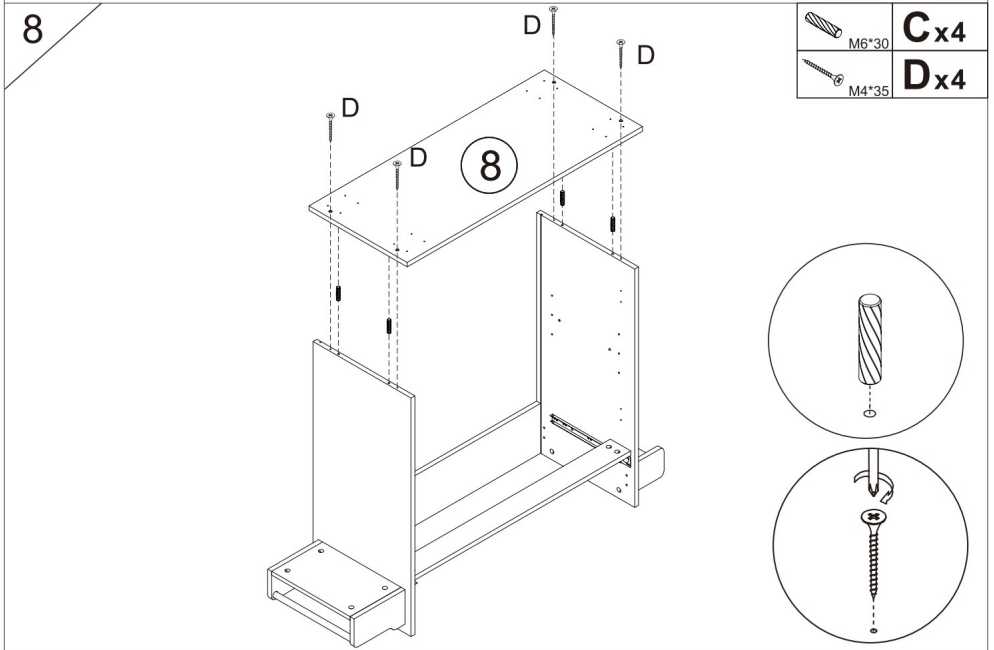
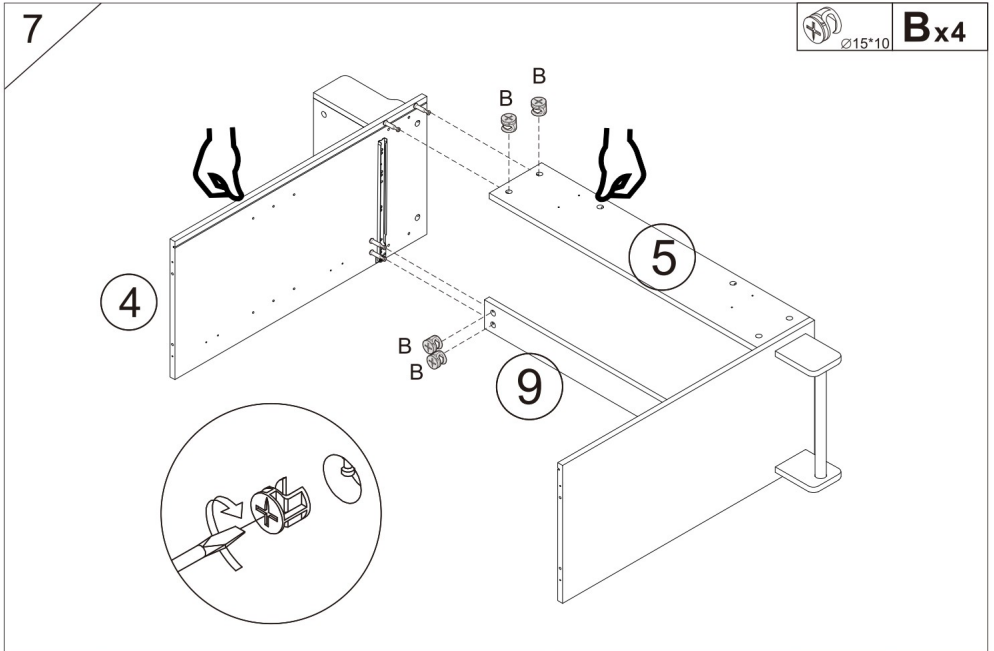

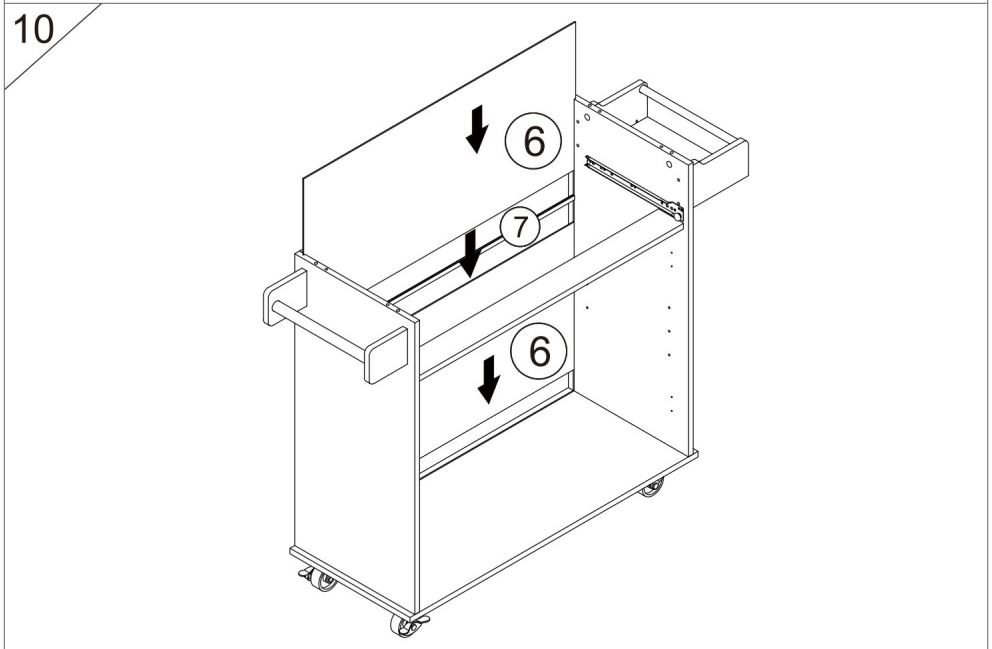
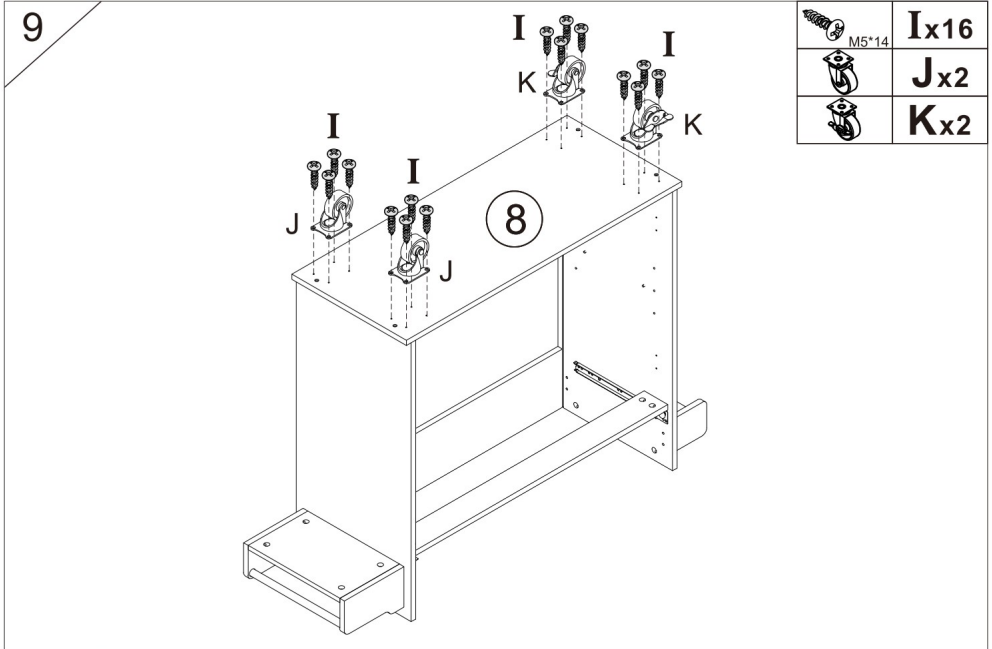

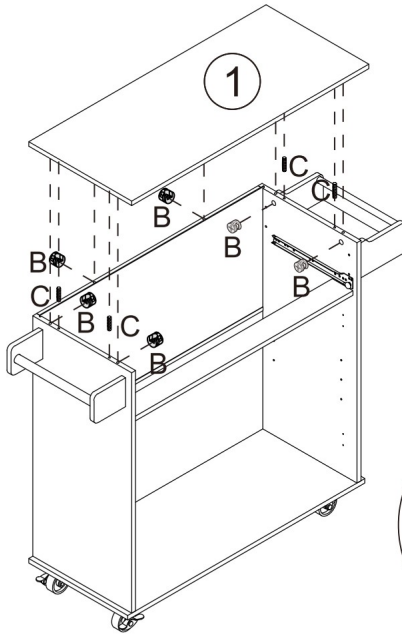

11



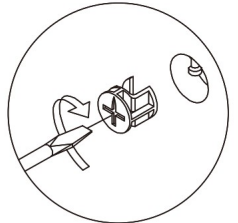
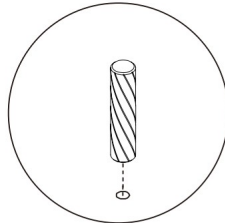

 $\varnothing 15 \times 10$	B x6
 M6 x 30	C x4

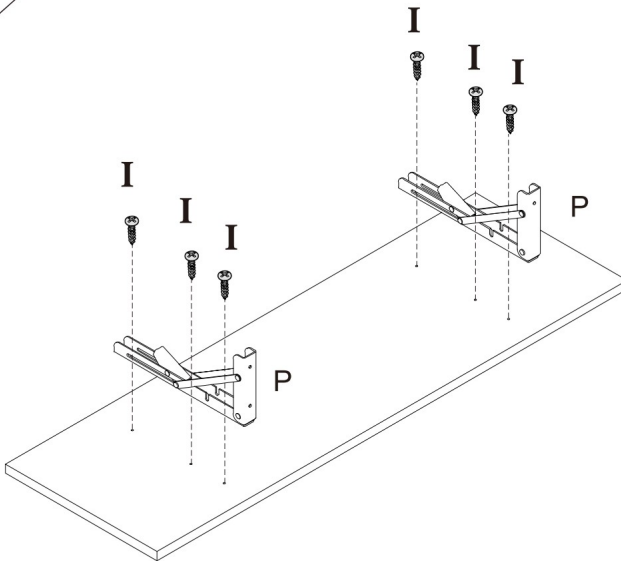

12



 M5 x 14	I x6
	P x2

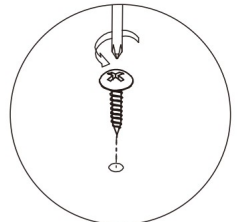
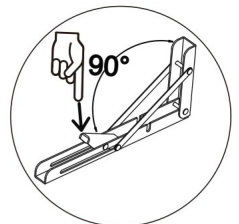

13

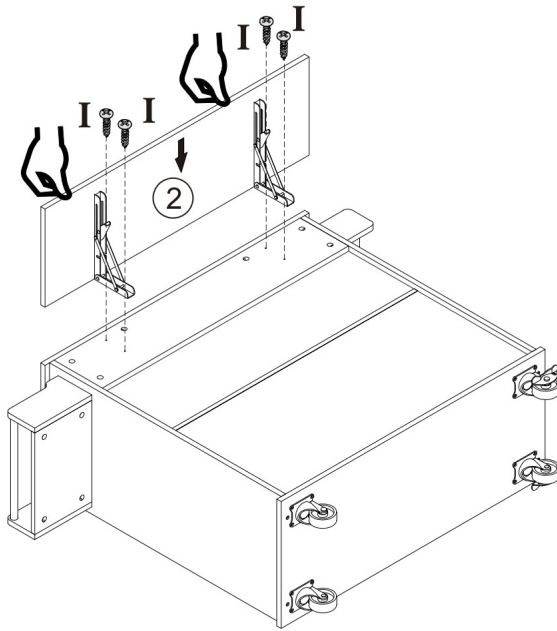

M5*14 **I**x4

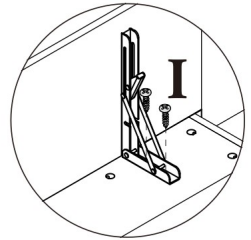
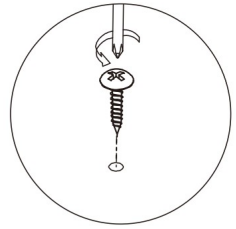

14

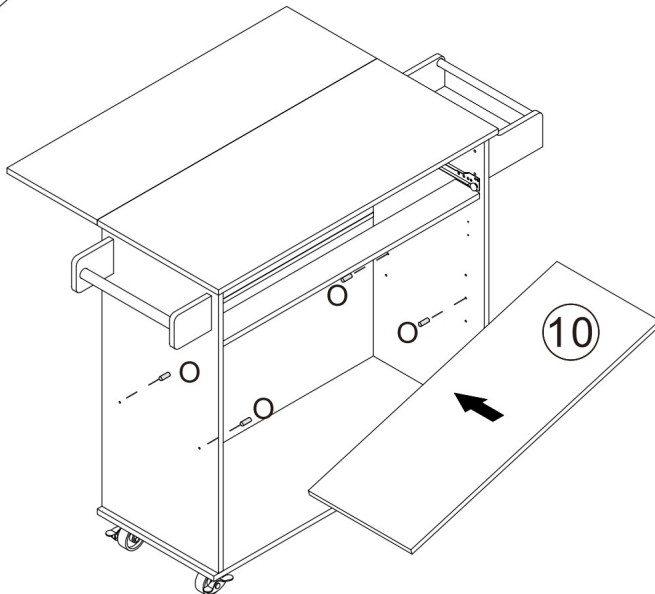

Ox4

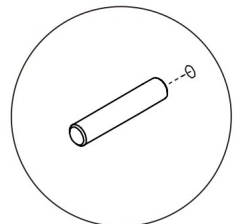



15

x2

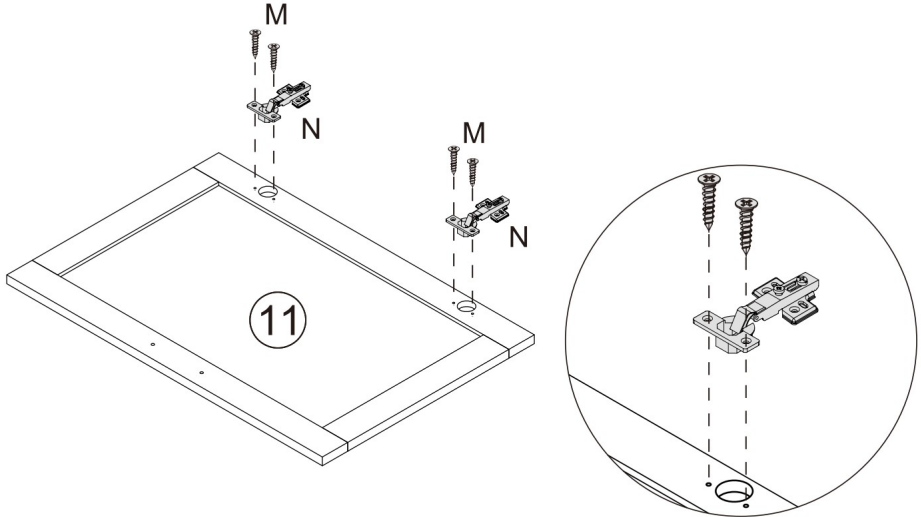
 M4*14	Mx8
	Nx4



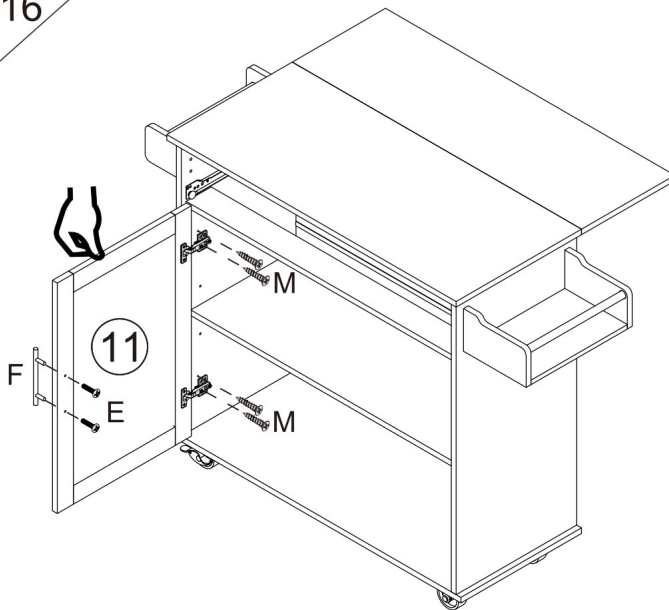

16

 M4*20	Ex2
	Fx1
 M4*14	Mx4



17

 M4*20	E x2
	F x1
 M4*14	M x4

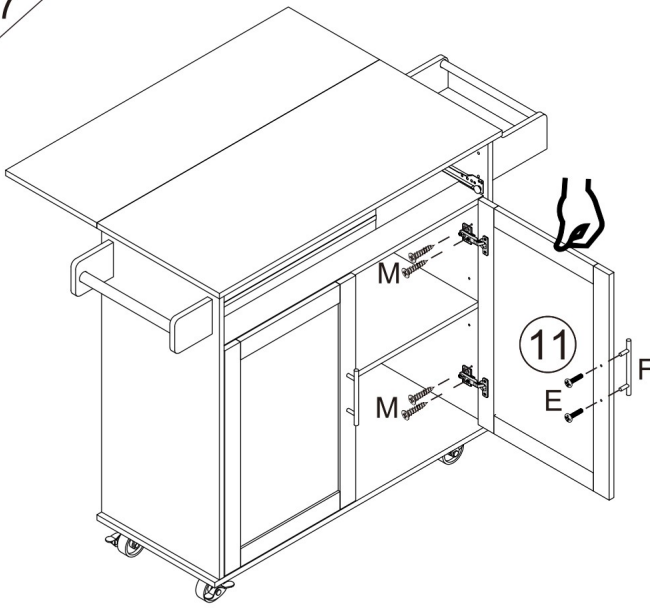

18

 M4*14	M x8
---	-------------

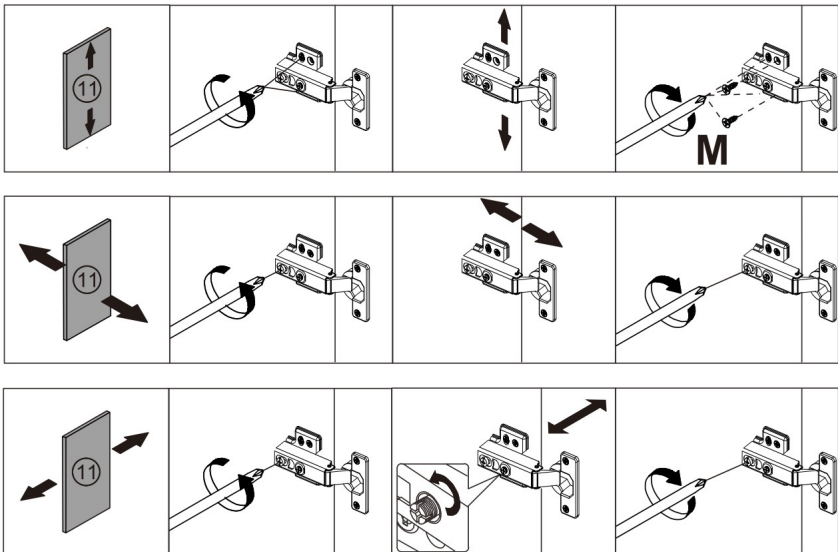

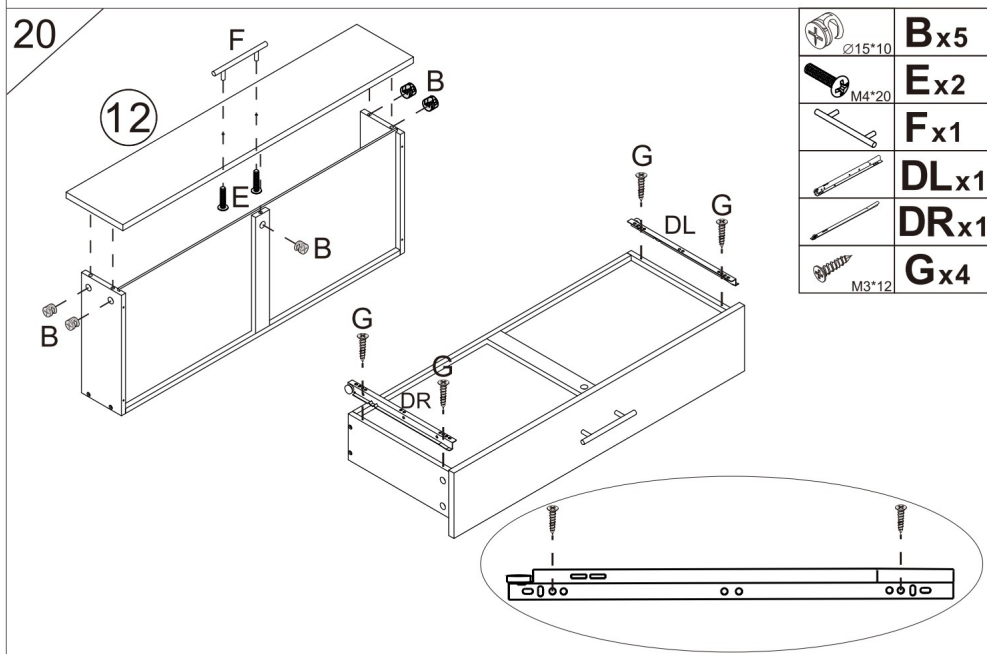
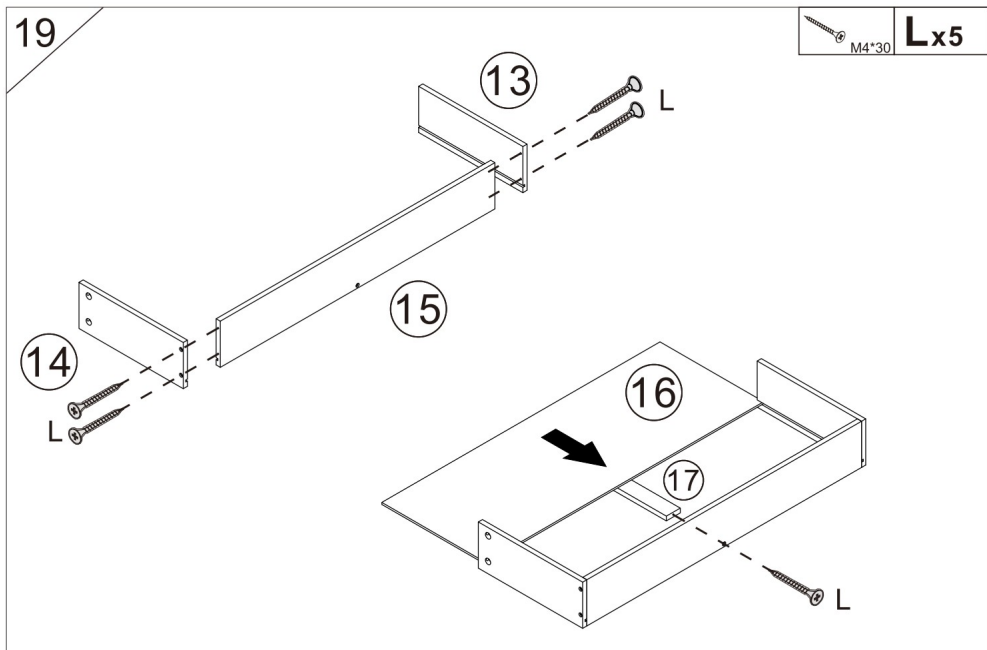

21

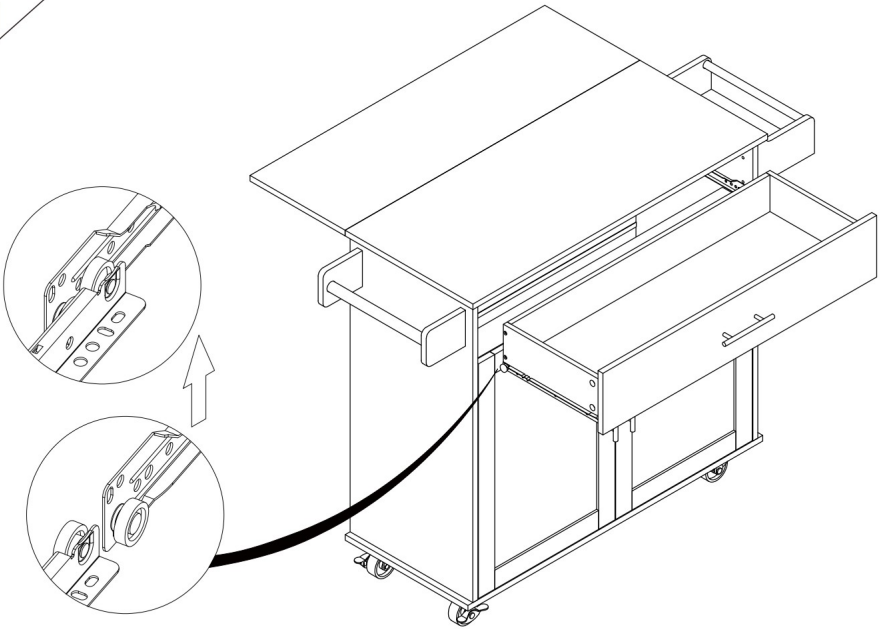

22

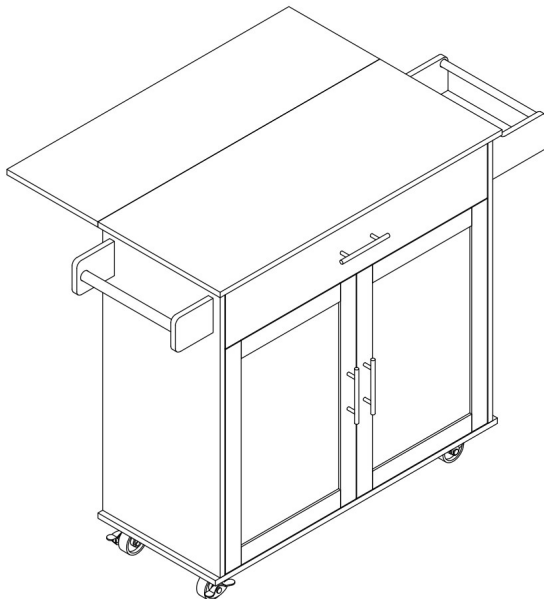

General Care

1. Make sure each layer should not exceed 40lb loading weight.
2. Make sure Folding board should not exceed 37lb loading weight.

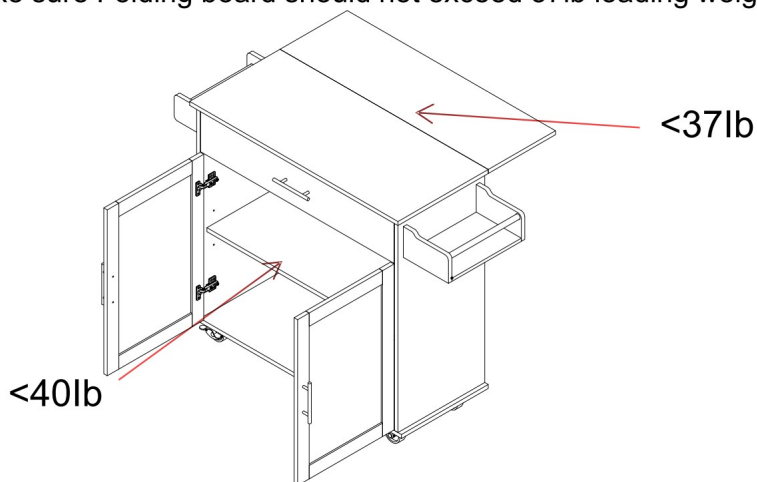

3. Make sure each drawer should not exceed 28lb loading weight.

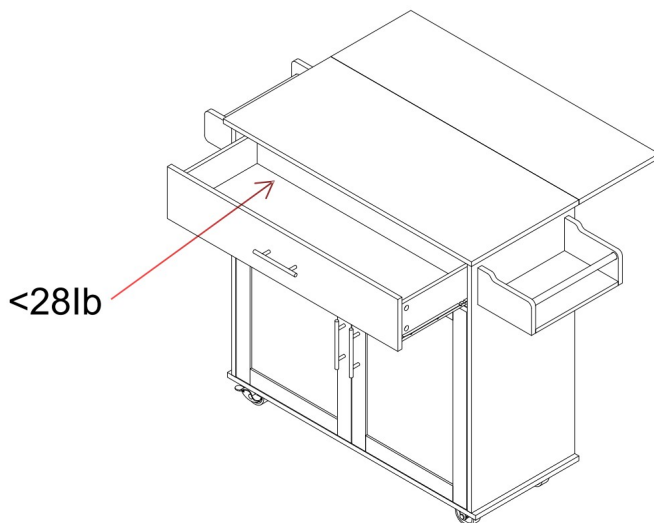

Cleaning

-For cleaning, wipe the surface with a damp (not wet) cloth or wipe dry with a clean lint free cotton cloth.

Tillverkare: Shanghaimuxinmuyeyouxiangongsi

Adress: Shuangchenglu 803nong11hao1602A-1609shi, baoshanqu, shanghai 200000 CN.

Importerad till AUS: SIHAO PTY LTD. 1 ROKEVA STREETEASTWOOD NSW 2122 Australien

Importerad till USA: Sanven Technology Ltd. Suite 250, 9166 Anaheim Place, Rancho Cucamonga, CA 91730



E-CrossStu GmbH
Mainzer Landstr.69, 60329 Frankfurt am Main.



YH CONSULTING LIMITED.
C/O YH Consulting Limited Office 147, Centurion House,
London Road, Staines-upon-Thames, Surrey, TW18 4AX

VEVOR[®]

TOUGH TOOLS, HALF PRICE

Support and E-Warranty Certificate <https://www.vevor.com/support>