

VEVOR

Affordable. Reliable. Home Improvement.

METAL CHICKEN COOP

MODEL:CRCFG0103

VEVOR

Affordable. Reliable. Home Improvement.

METAL CHICKEN COOP

MODEL: CRCFG0103

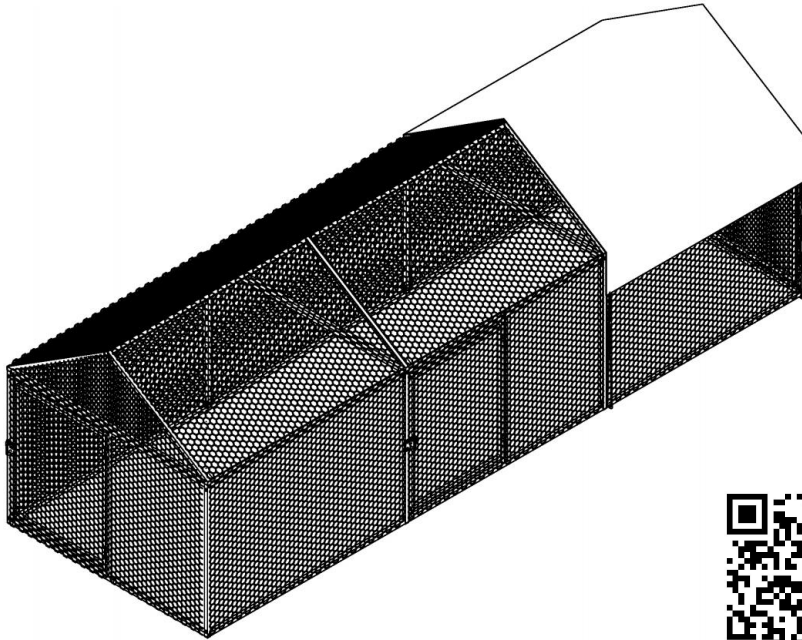

**Video
installation QR**

This is the original instruction, please read all manual instructions carefully before operating. VEVOR reserves a clear interpretation of our user manual. The appearance of the product shall be subject to the product you received. Please forgive us that we won't inform you again if there are any technology or software updates on our product.

SAFETY INSTRUCTIONS

WARNING:

Read this material before using this product. Failure to do so can result in serious injury.

Assembly precautions

1. Assemble only according to these instructions. Improper assembly can create hazards.
2. Wear ANSI-approved safety goggles and heavy-duty work gloves during assembly.
3. Keep the assembly area clean and well-lit.
4. Keep bystanders out of the area during assembly.
5. Do not assemble if tired or when under the influence of alcohol, drugs or medication.
6. The product capabilities apply to properly and completely assembled products only.
7. For additional information regarding the parts listed in the following pages, please refer to the Assembly Diagram of this manual. Unwrap and separate all parts in a clean work area.
8. There are many product components. It is recommended that two people carry out the installation, which can shorten the installation time.

Use precautions

1. DO NOT SIT OR STAND ON THIS ITEM.
2. This product is not a toy. Do not allow children to play with or near this item.
3. Do not exceed specified weight capacities.
4. Use as intended only.
5. Inspect before every use; do not use if parts are loose or damaged.

SAVE THIS MANUAL

TOOLS





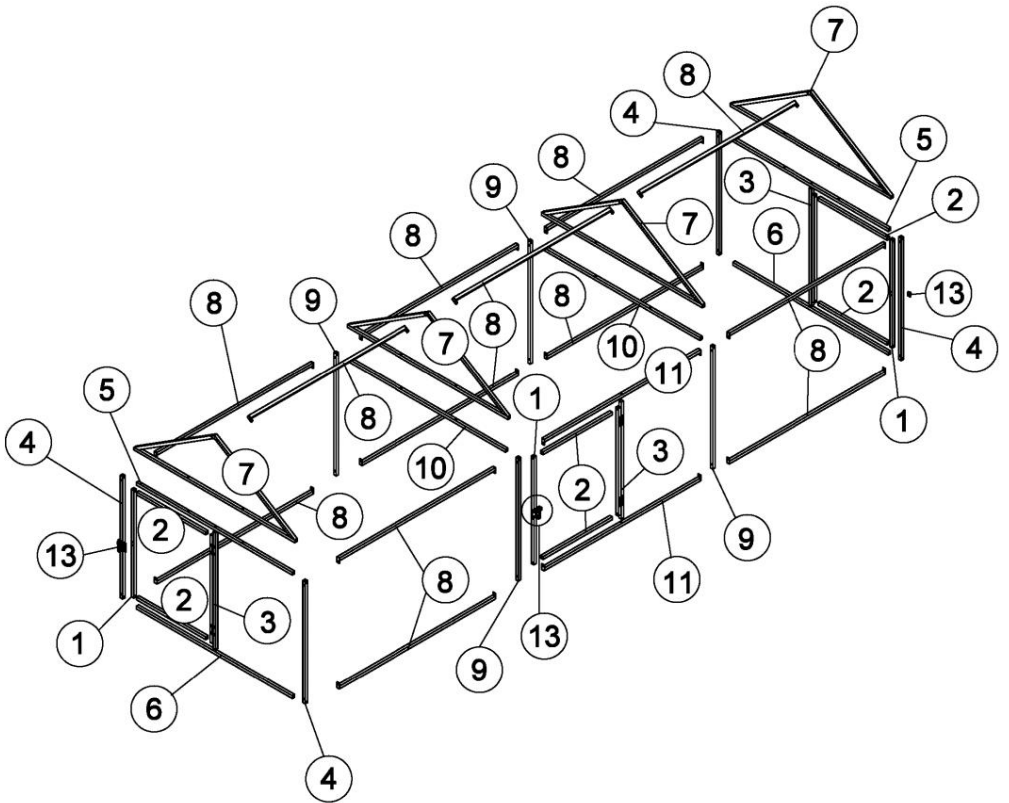

PARTS LIST

Item no.	Reference Image	Qty.	Item no.	Reference Image	Qty.
1		x3	2		x6
3		x3	4		x4
5		x2	6		x2
7		x4	8		x13
9		x4	10		x2
11		x2	13		x3
14		x58	15		x28
16		x1	17		x28
18	 1*12M	x1	19		x12
wire		x1	20		x8
21		x100			

EXPLODED VIEW



ASSEMBLY





STEP1										
	1	X3	2	X6	3	X3	17	X12	14	X12

x3

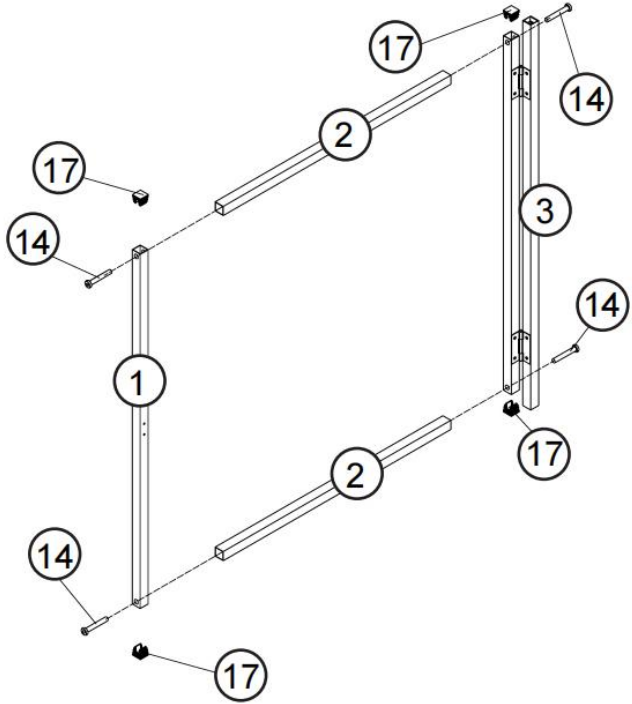
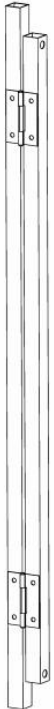
Before



After



STEP2										
	4	X4	5	X2	6	X2	17	X4	14	X12

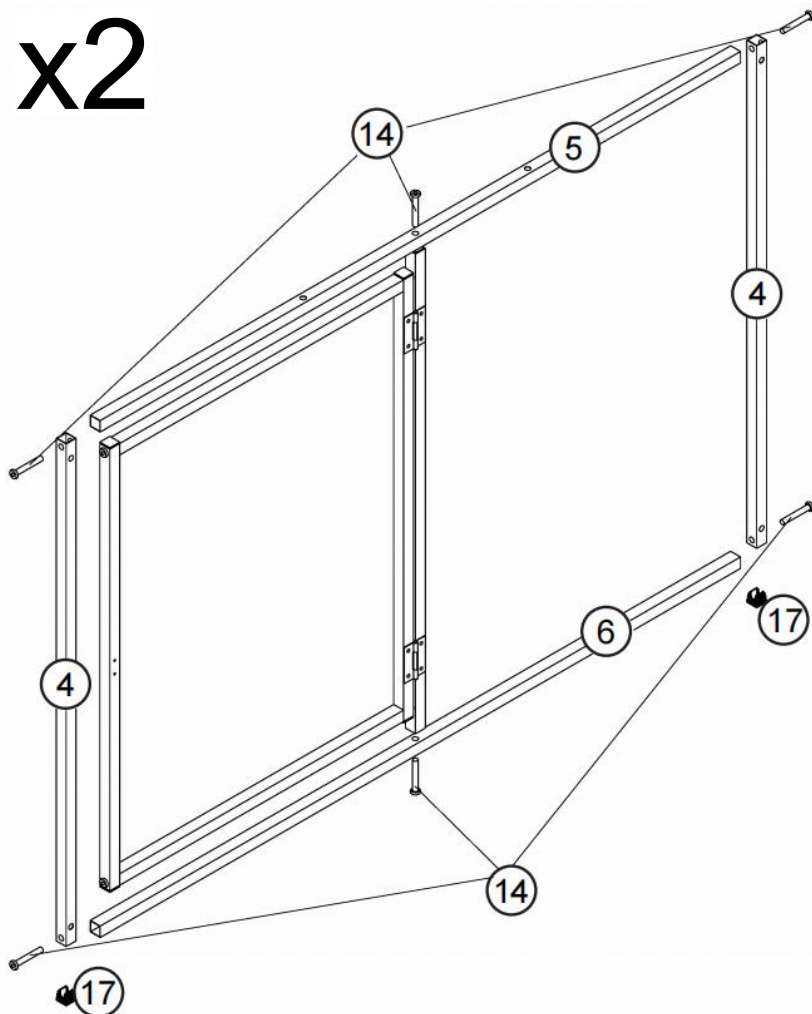

x2



STEP3				
	7	X4	17	X8

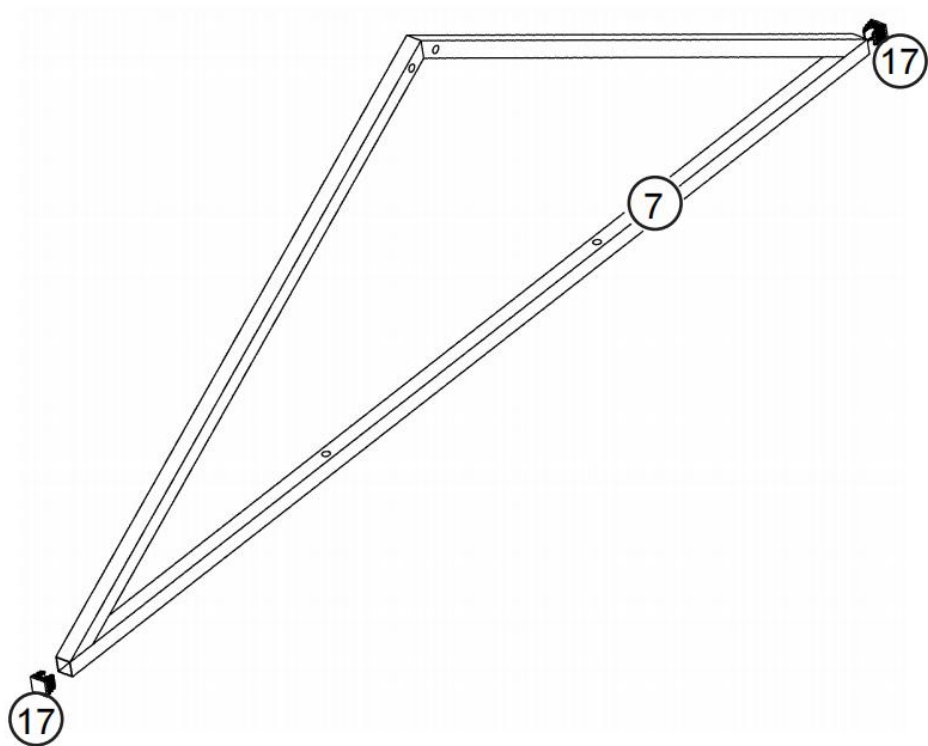

x4





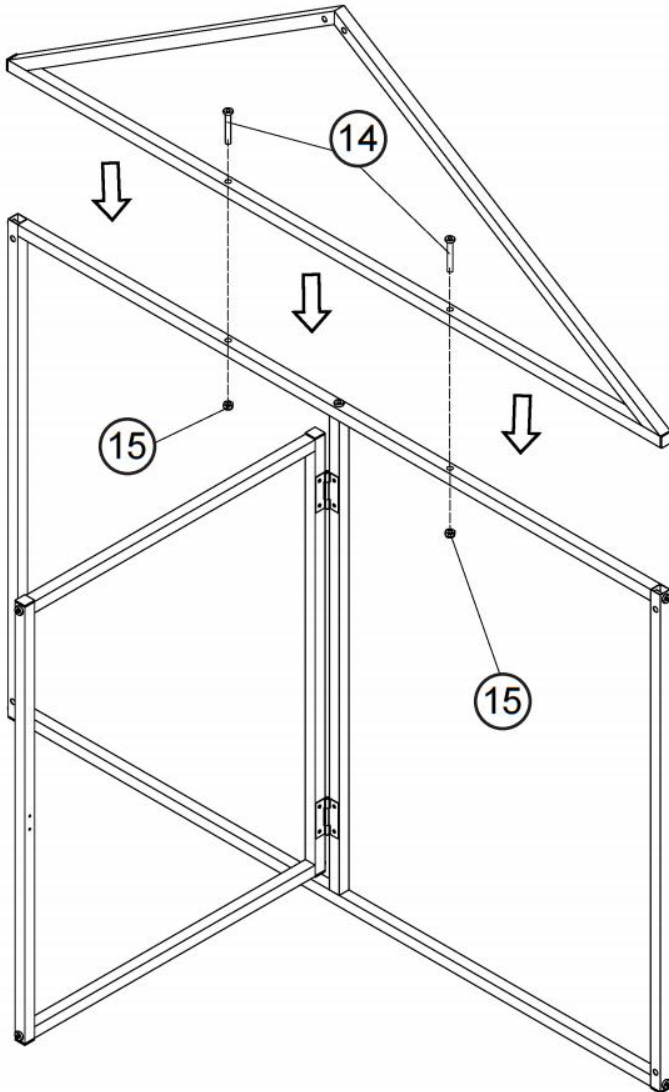

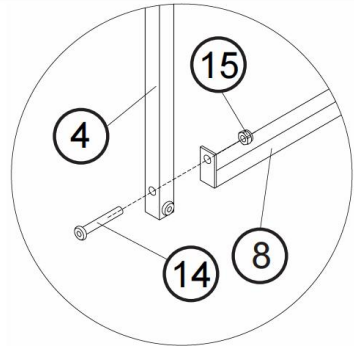
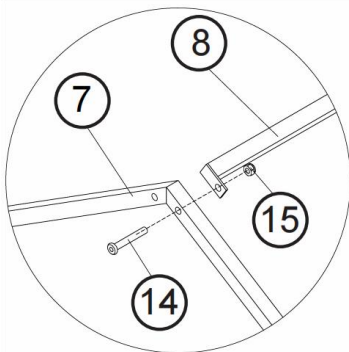
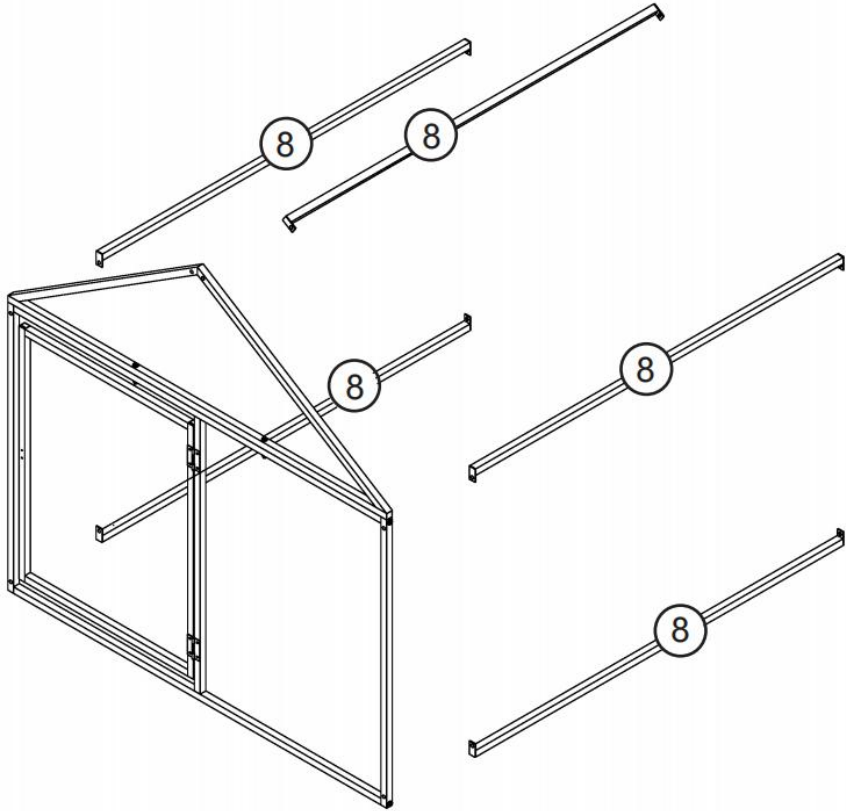

STEP4				
	14	X4	15	X4

x2





STEP5						
	8	X5	14	X5	15	X5





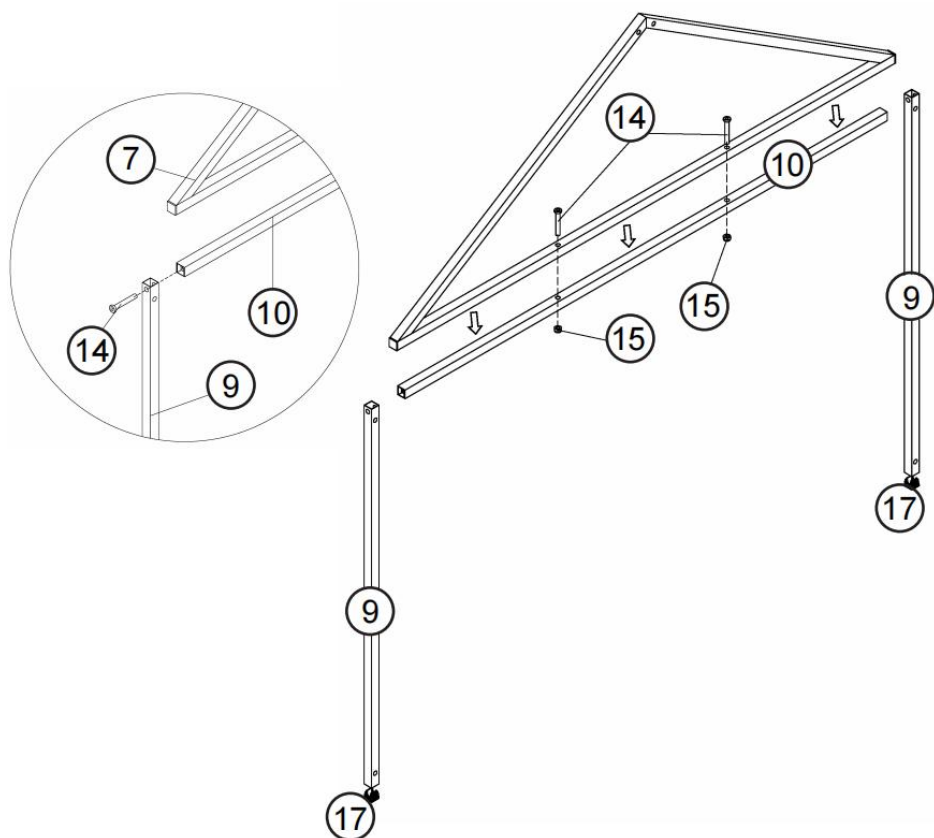

STEP6										
	9	X4	10	X2	14	X8	15	X4	14	X4

x2

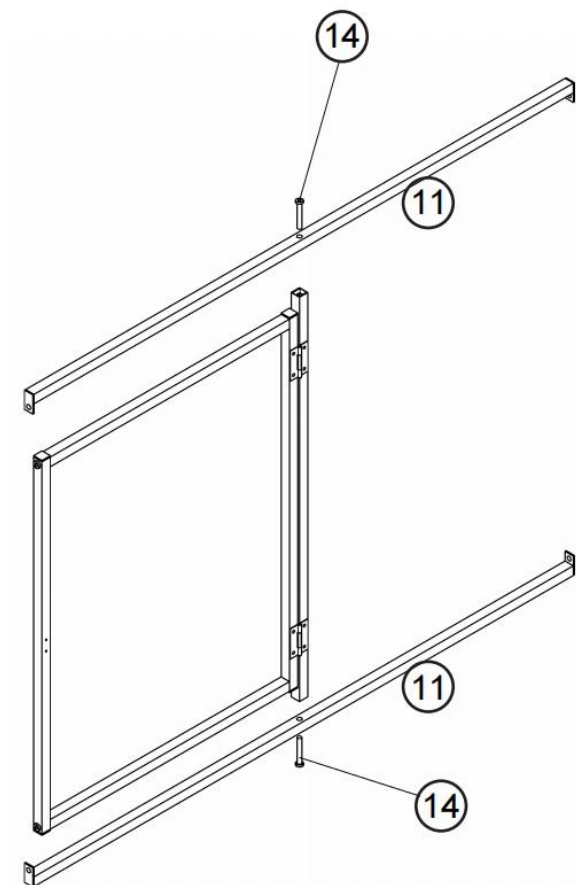
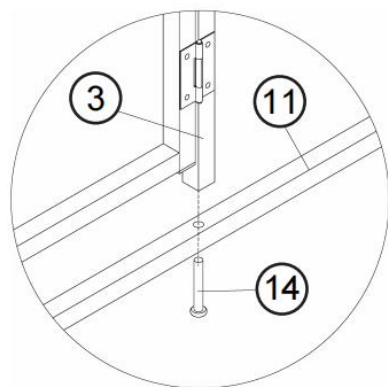



STEP7				
	11	X2	14	X2



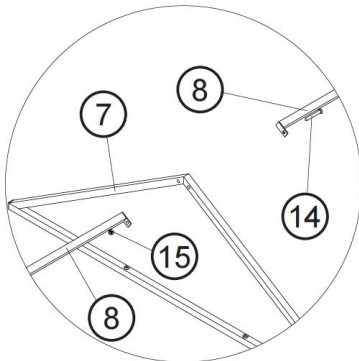
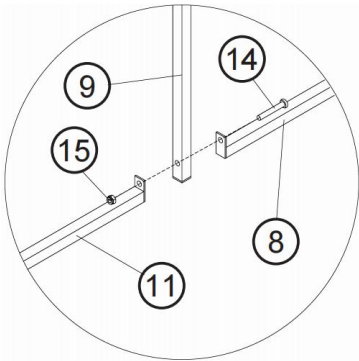
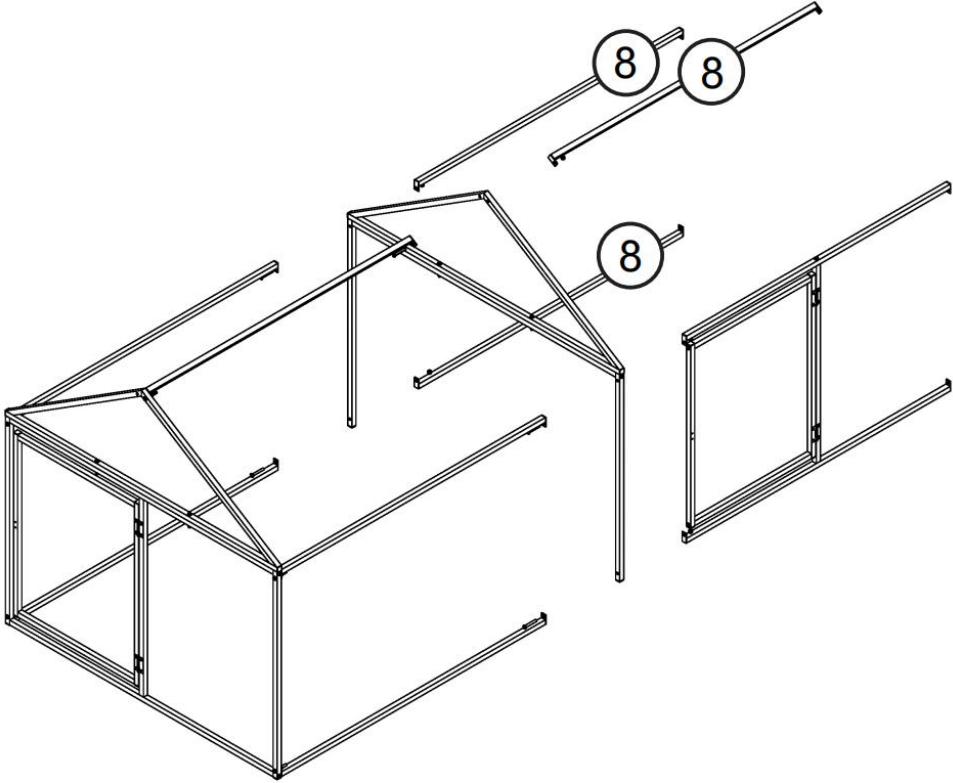

STEP8						
	8	X3	14	X5	15	X5

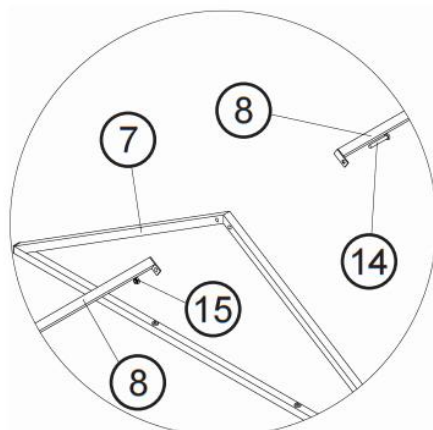
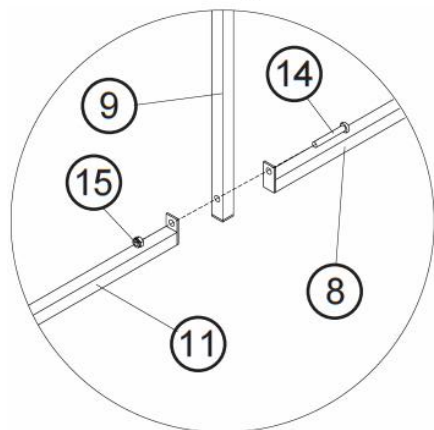
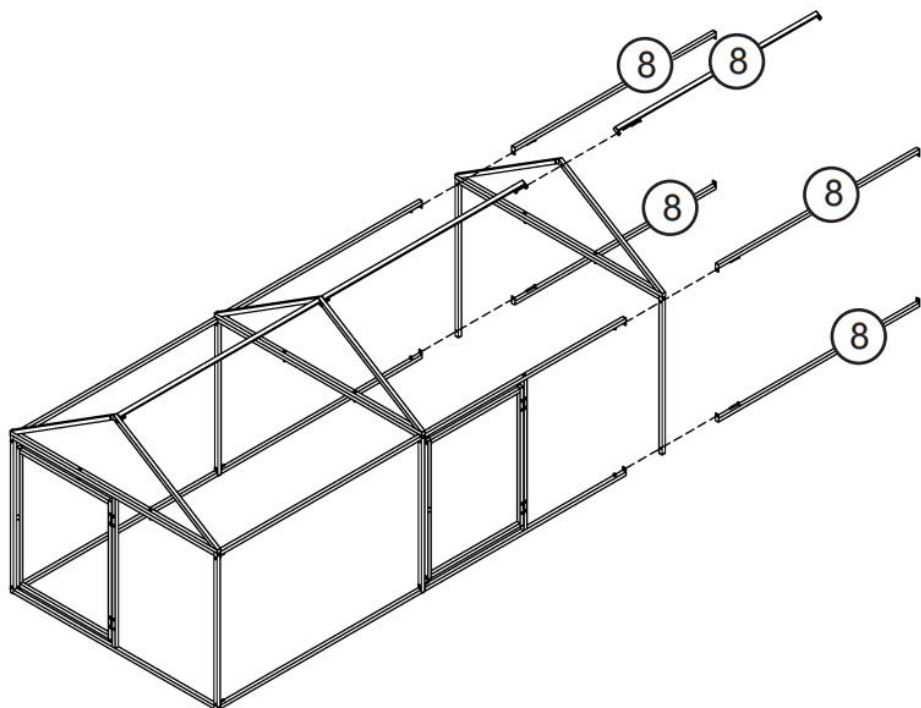

STEP9						
	8	X5	14	X5	15	X5



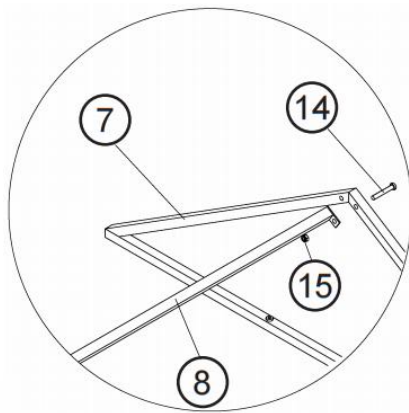
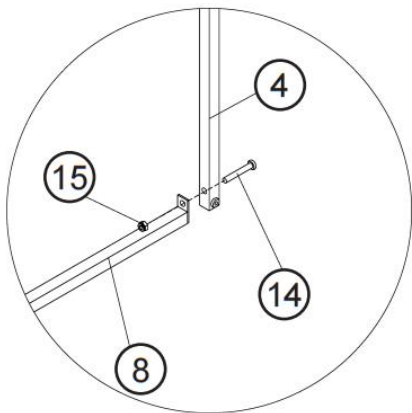
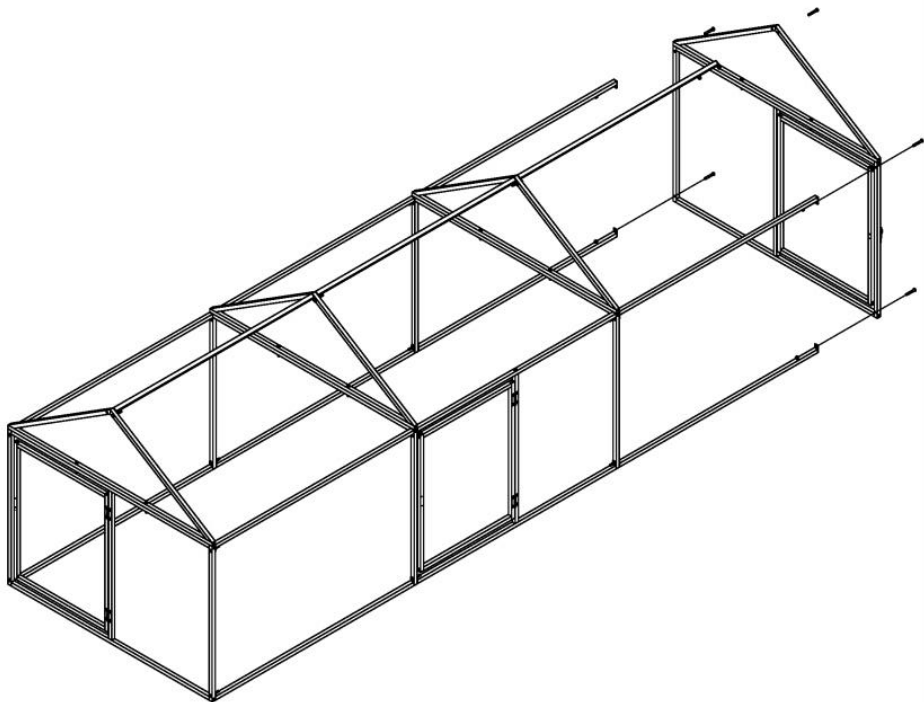

STEP10				
	14	X5	15	X5

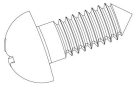

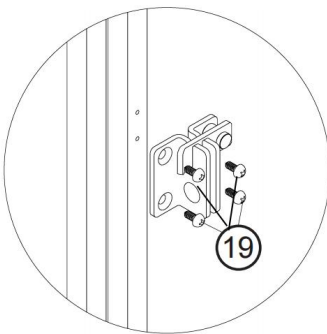
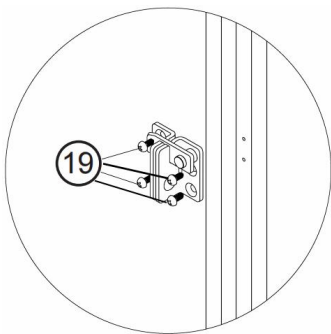
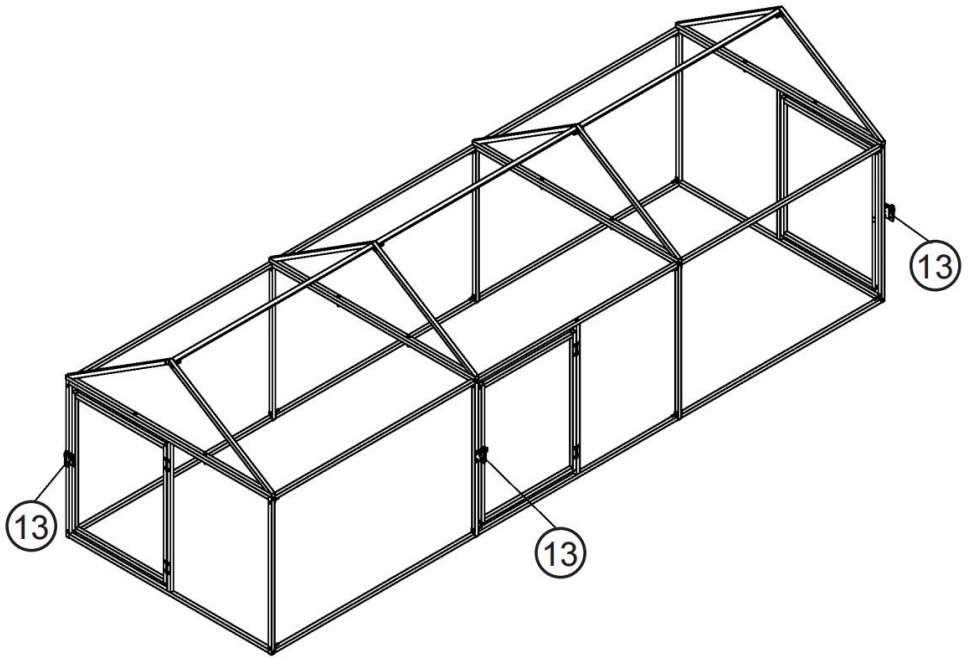
STEP11				
	13	X3	19	X12



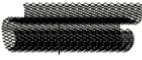

The holes for the left section needs to be drilled by yourself because the door maybe tilt after assembling due to gravity,so adjust the left section's position to make door close properly

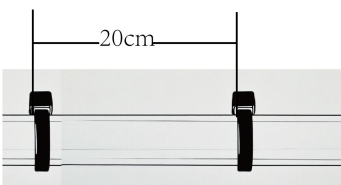
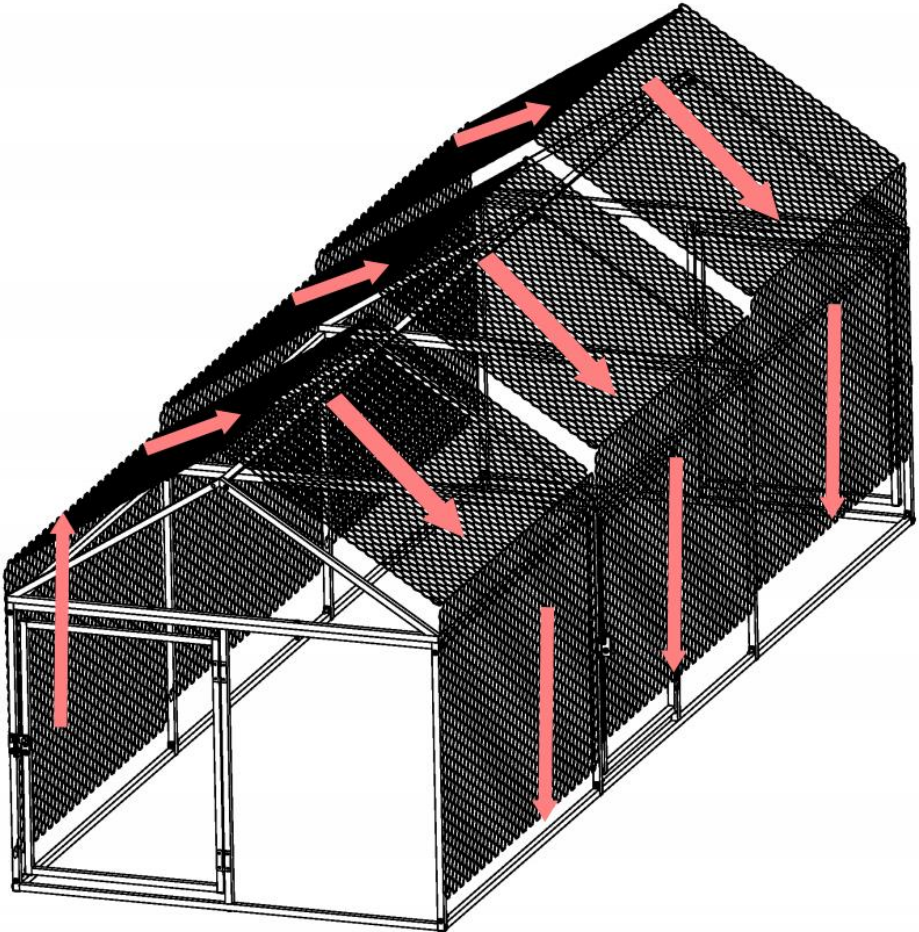
STEP12				
	F	X1	N	X60



Use zip ties to tie the wire mesh and steel pipes together, with an interval of 20cm between each tie. Tighten the wire mesh by lowering the zip ties

STEP13				
	F		N	X40

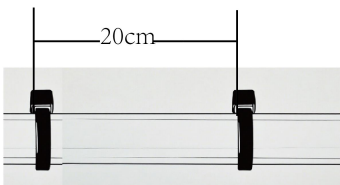
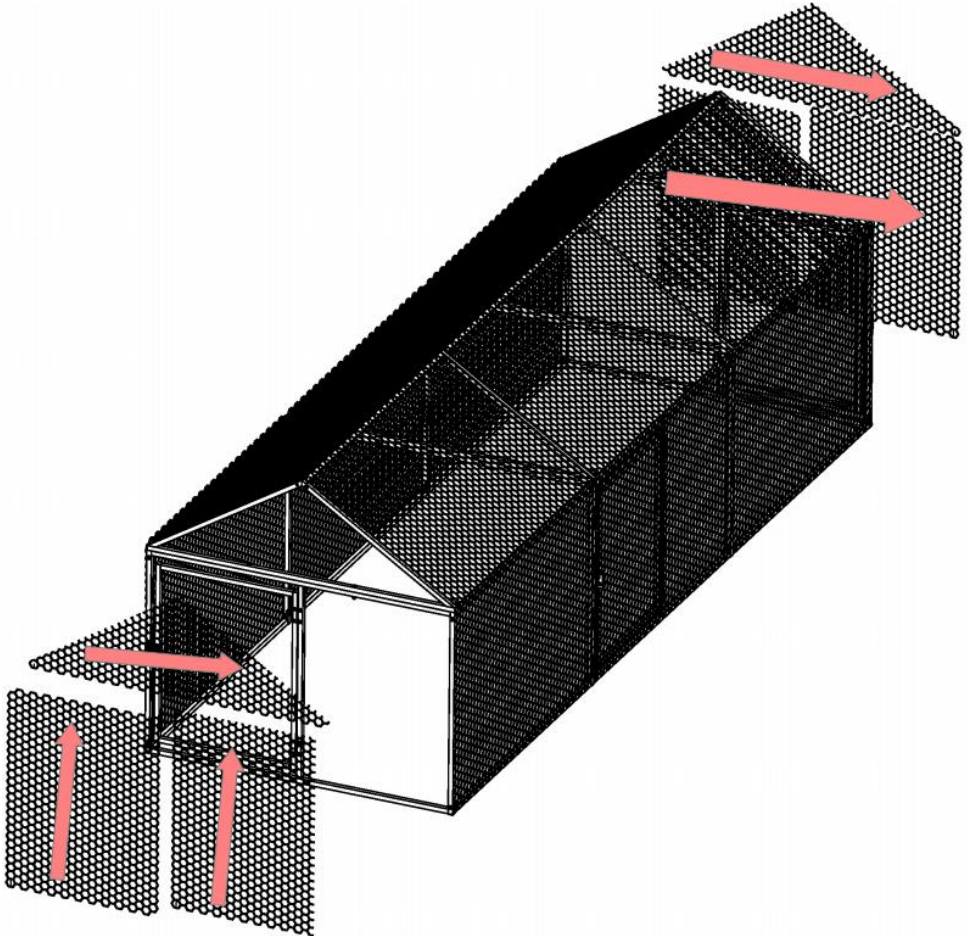

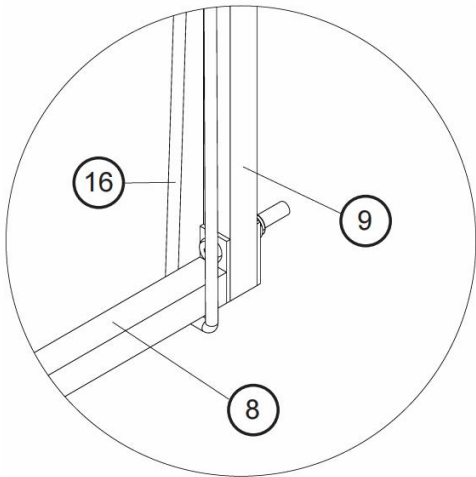
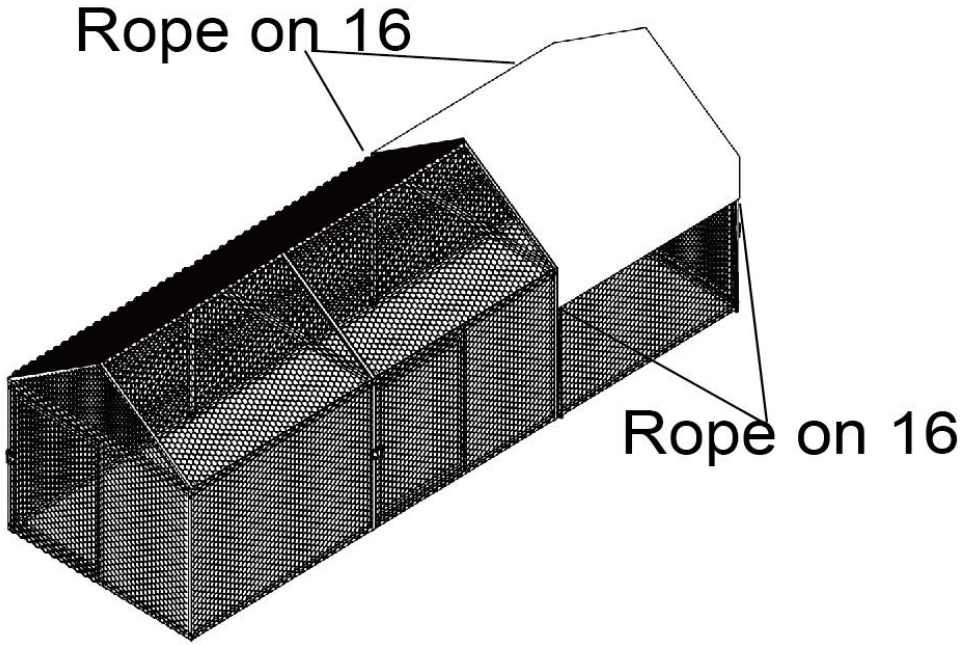

Use zip ties to tie the wire mesh and steel pipes together, with an interval of 20cm between each tie. Tighten the wire mesh by lowering the zip ties

STEP14		
	16	X1

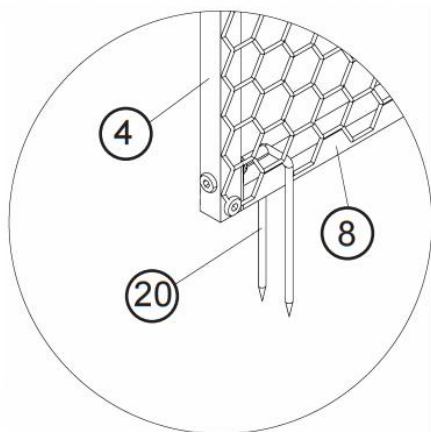
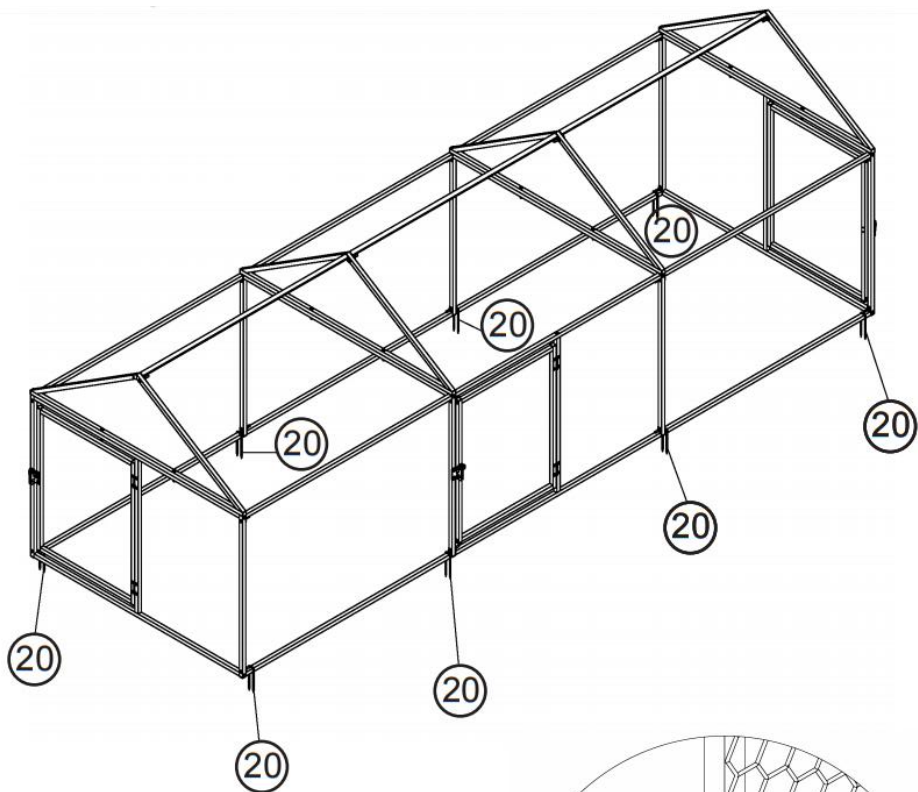

STEP15		
	20	X8



STEP16		
	Wire	X1

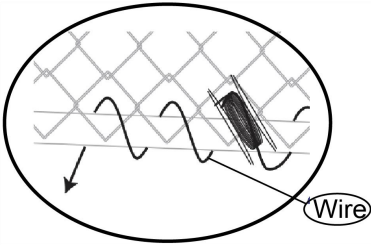
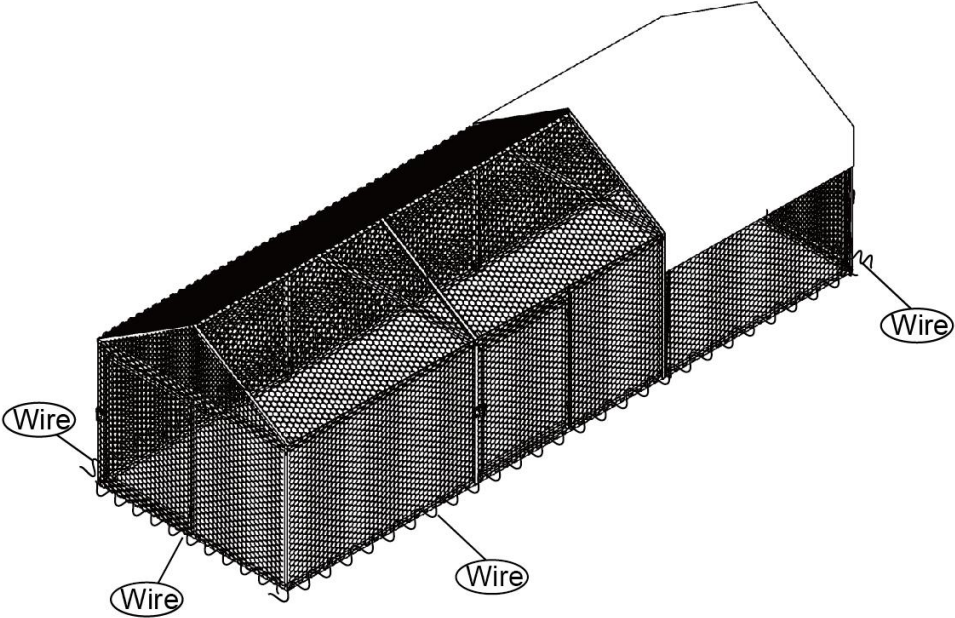

Note

Spiral wrap the wire at the bottom to reinforce the wire mesh and steel pipe, with a distance of 15cm between each circle. The single wire should not be wrapped more than 2 meters, and it needs to be tightened during wrapping. The knot should be firm and not loosened

PRODUCT PARAMETER

Model	CRCFG0103
Colour	Black + White
Product Size	3000×1000×1000mm
Material	Q235+PE Cloth

NOTICE

Site planning and selection

Choose areas with high terrain and good drainage to avoid metal parts rusting due to water accumulation during the rainy season; Level the site in advance, remove stones, weeds, and other debris, and if necessary, lay concrete foundations (especially for large metal chicken coops) to enhance stability.

Material inspection and tool preparation

Check whether the metal sheet, frame, screws and other accessories are intact, whether there is deformation, rust or damage, and prepare professional tools such as electric drills, wrenches, tape measures, cutting tools (if necessary to adjust the size of the sheet), etc.

Comprehensive inspection after installation

Check whether the overall structure is stable, whether the boards are loose or deformed, whether the door and window switches are smooth, and whether the ventilation openings are working properly. Regularly clean the feces and debris in the chicken coop to prevent the accumulation of dirt from corroding metal parts. Check the tightening of screws and the integrity of anti rust coatings once a quarter, inspect the binding of nets for looseness, and promptly deal with any problems found to extend the service life of the chicken coop.

Manufacturer: Shanghaimuxinmuyeyouxiangongsi

Address: Shuangchenglu 803nong11hao1602A-1609shi, baoshanqu, shanghai 200000 CN.

Imported to AUS: SIHAO PTY LTD. 1 ROKEVA STREETEASTWOOD NSW 2122 Australia

Imported to USA: Sanven Technology Ltd. Suite 250, 9166 Anaheim Place, Rancho Cucamonga, CA 91730

UK	REP
-----------	------------

YH CONSULTING LIMITED. C/O YH Consulting Limited Office 147, Centurion House, London Road, Staines-upon-Thames, Surrey, TW18 4AX

EC	REP
-----------	------------

E-CrossStu GmbH
Mainzer Landstr.69,
60329 Frankfurt am Main.



VEVOR

Affordable. Reliable. Home Improvement.

POULAILLER EN MÉTAL

MODÈLE : CRCFG0103

VEVOR

Affordable. Reliable. Home Improvement.

METAL CHICKEN COOP

MODÈLE: CRCFG0103

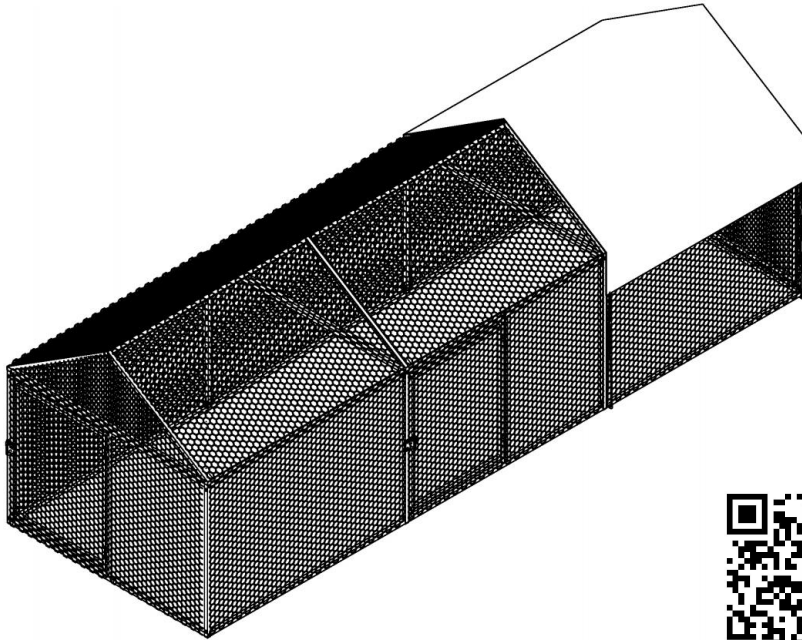

Video
installation QR

Ceci est le mode d'emploi d'origine. Veuillez lire attentivement l'intégralité du manuel avant utilisation. VEVOR se réserve le droit d'interpréter clairement ce manuel d'utilisation. L'apparence du produit dépend du produit que vous avez reçu. Veuillez nous excuser pour les éventuelles mises à jour technologiques ou logicielles.

SAFETY INSTRUCTIONS

AVERTISSEMENT:

Veillez lire attentivement ce document avant d'utiliser ce produit. Le non-respect de ces instructions peut entraîner des blessures graves.

Précautions de montage

1. Assemblez uniquement conformément à ces instructions. Un assemblage incorrect peut créer des dangers.
2. Portez des lunettes de sécurité approuvées ANSI et des gants de travail robustes pendant l'assemblage.
3. Gardez la zone de montage propre et bien éclairée.
4. Gardez les spectateurs hors de la zone pendant le montage.
5. Ne pas monter si vous êtes fatigué ou sous l'influence de l'alcool, de drogues ou de médicaments.
6. Les capacités du produit s'appliquent uniquement aux produits correctement et entièrement assemblés.
7. Pour plus d'informations sur les pièces listées dans les pages suivantes, veuillez vous référer au schéma d'assemblage de ce manuel. Déballer et séparer toutes les pièces dans un espace de travail propre.
8. Le produit comporte de nombreux composants. Il est recommandé de faire appel à deux personnes pour l'installation, ce qui peut réduire le temps d'installation.

Précautions d'emploi

1. NE PAS S'ASSEOIR NI SE TENIR DEBOUT SUR CET ARTICLE.
2. Ce produit n'est pas un jouet. Ne laissez pas les enfants jouer avec ou à proximité de cet article.
3. Ne pas dépasser la dose spécifiée capacités de poids.
4. Utiliser uniquement comme prévu.
5. Inspectez avant chaque utilisation ; ne pas utiliser si des pièces sont desserrées ou endommagées.

CONSERVEZ CE MANUEL

TOOLS





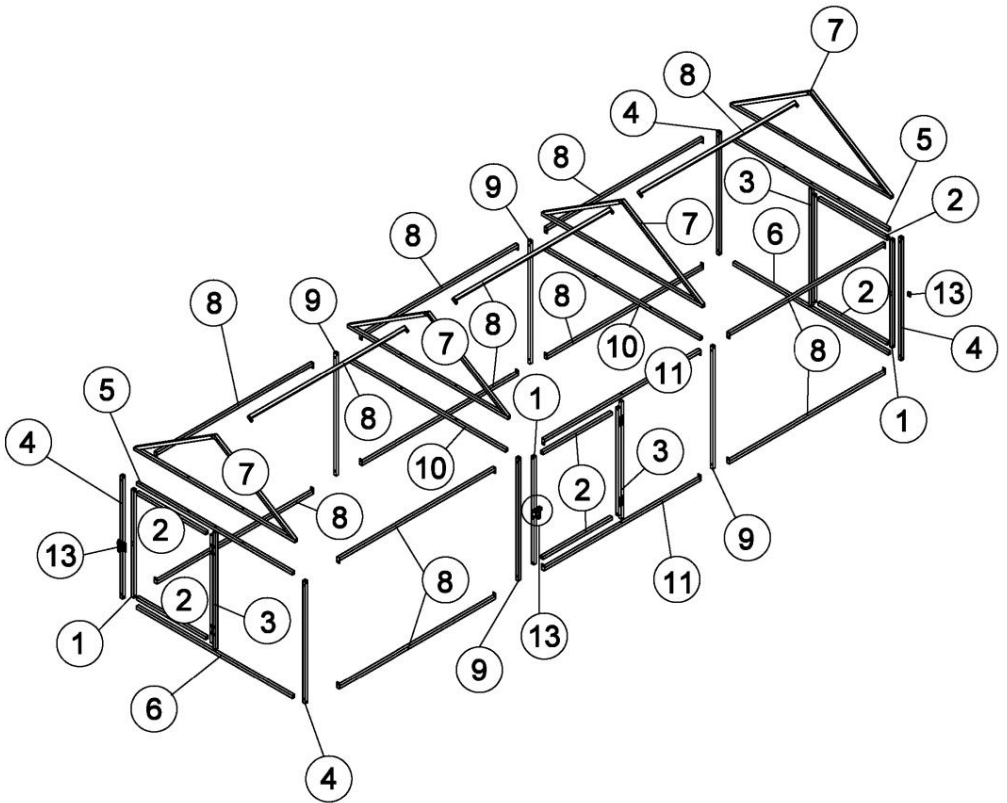

PARTS LIST

Item no.	Reference Image	Qty.	Item no.	Reference Image	Qty.
1		x3	2		x6
3		x3	4		x4
5		x2	6		x2
7		x4	8		x13
9		x4	10		x2
11		x2	13		x3
14		x58	15		x28
16		x1	17		x28
18	 1*12M	x1	19		x12
wire		x1	20		x8
21		x100			

EXPLODED VIEW



ASSEMBLY





ÉTAPE 1										
	1	X3	2	X6	3	X3	17	X12	14	X12

x3

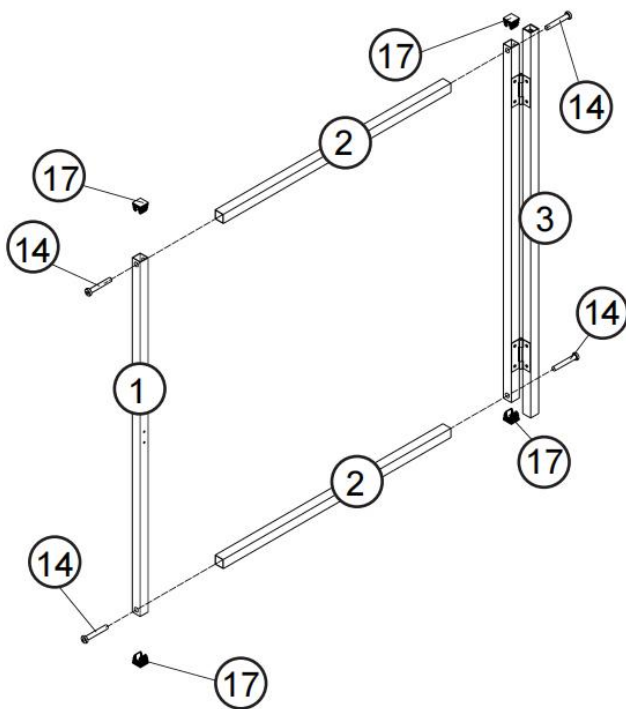
Before



After



ÉTAPE 2										
	4	X4	5	X2	6	X2	17	X4	14	X12

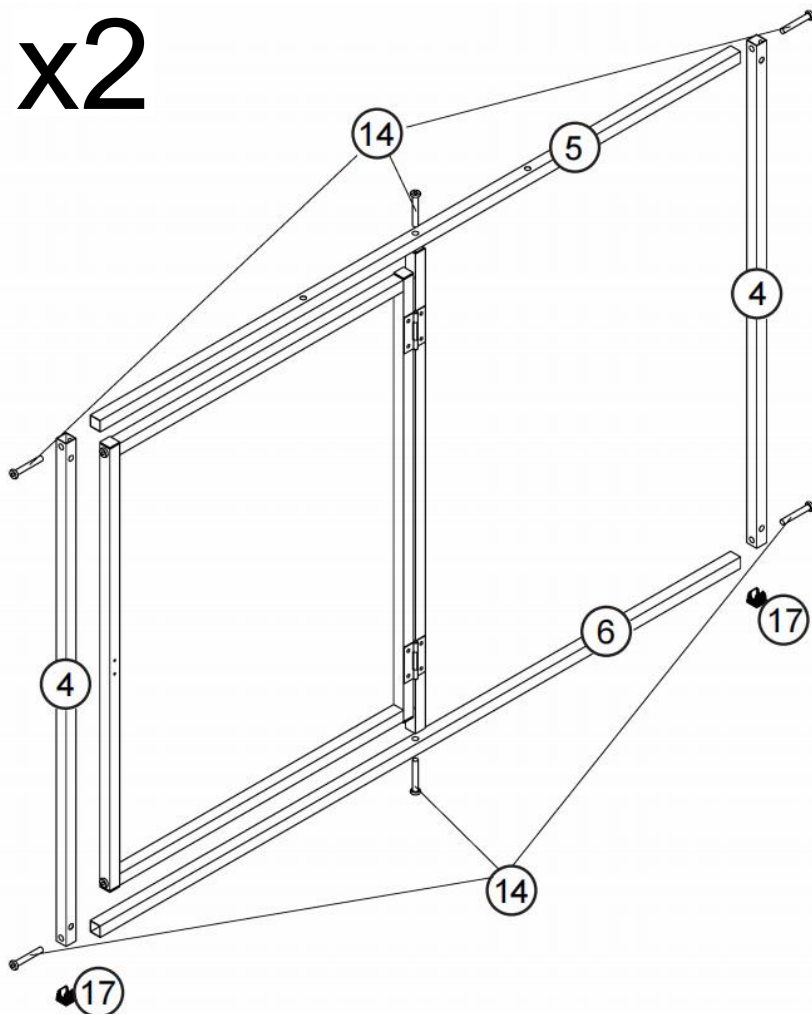

x2



ÉTAPE 3				
	7	X4	17	X8

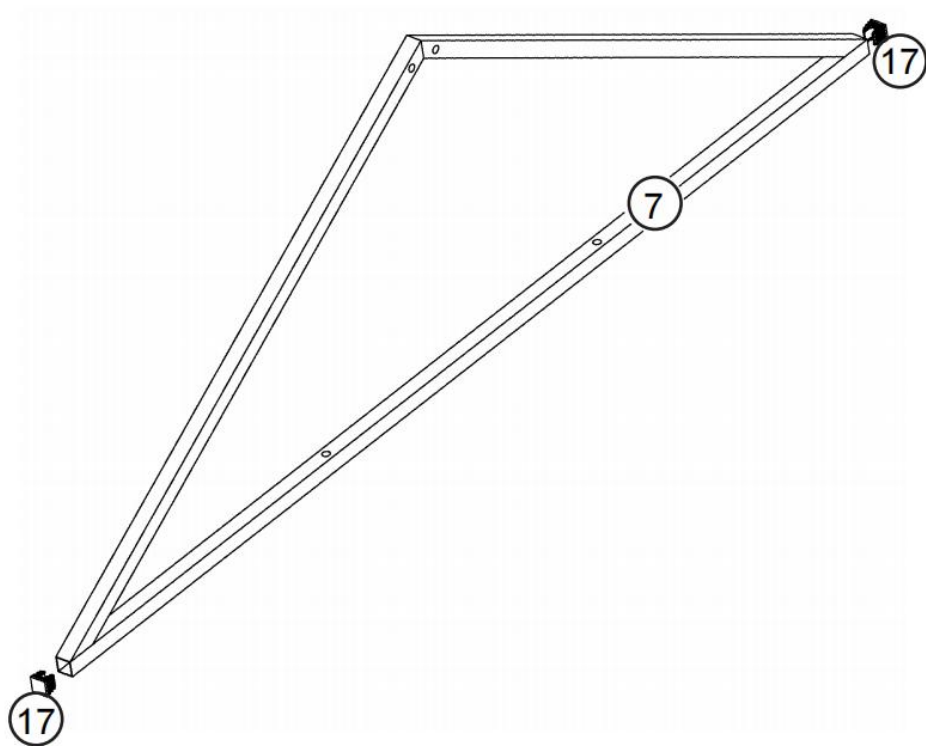

x4





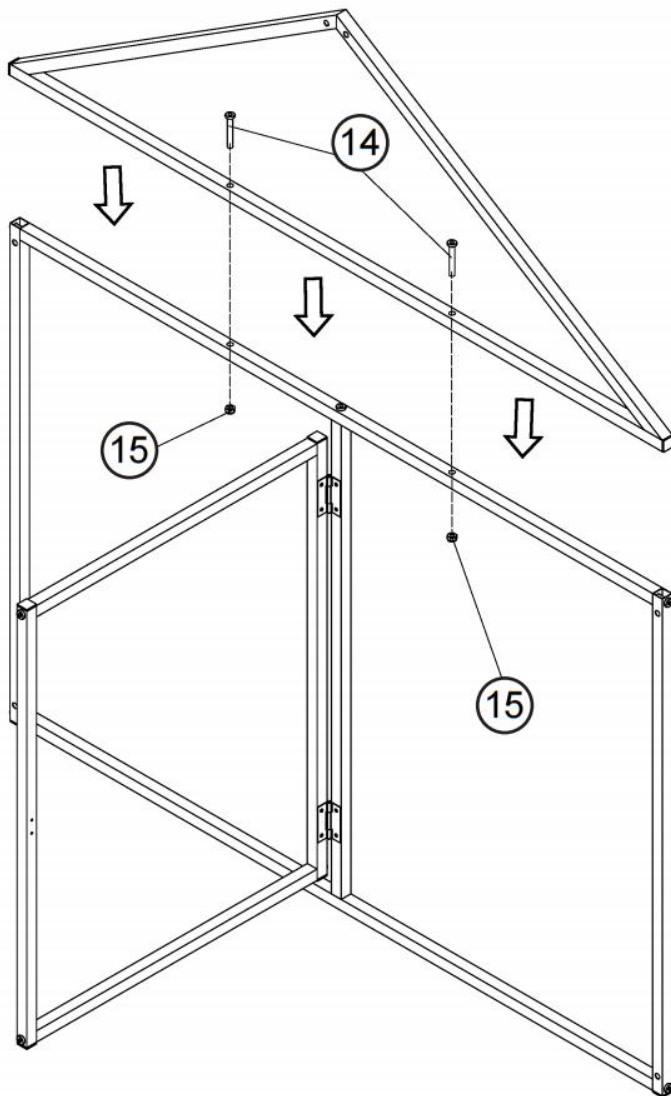

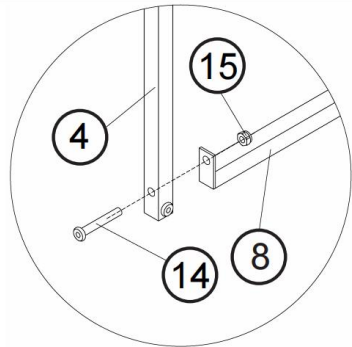
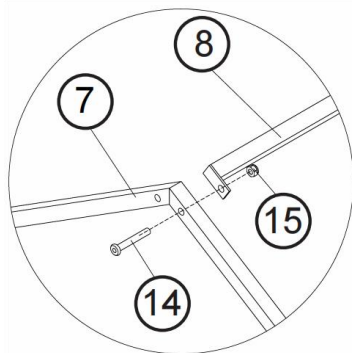
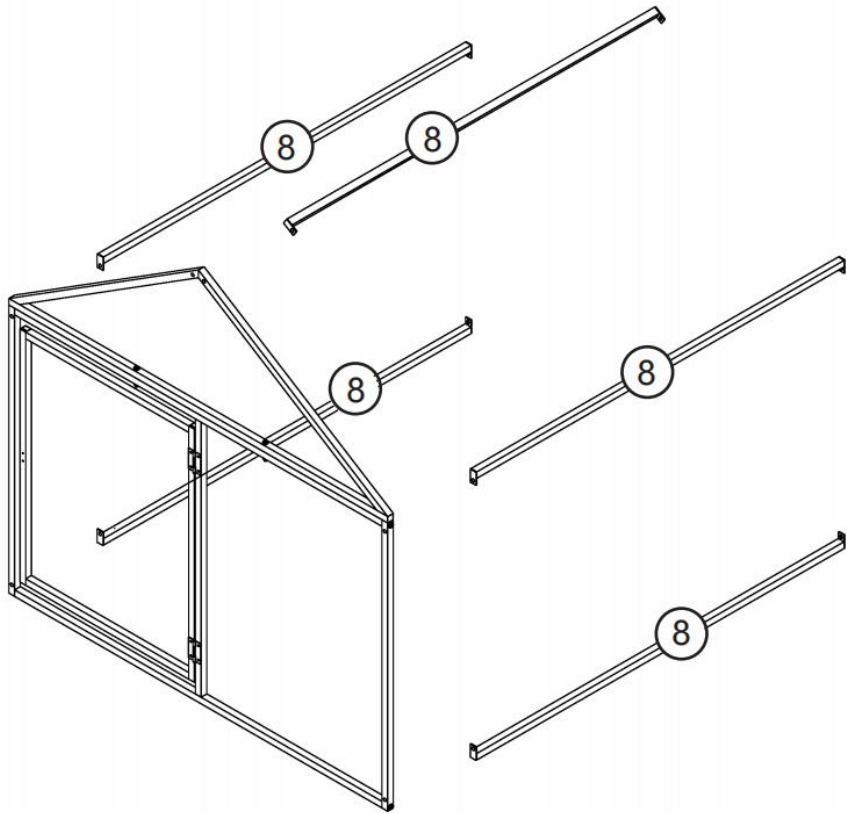

ÉTAPE 4				
	14	X4	15	X4

x2





ÉTAPE 5						
	8	X5	14	X5	15	X5





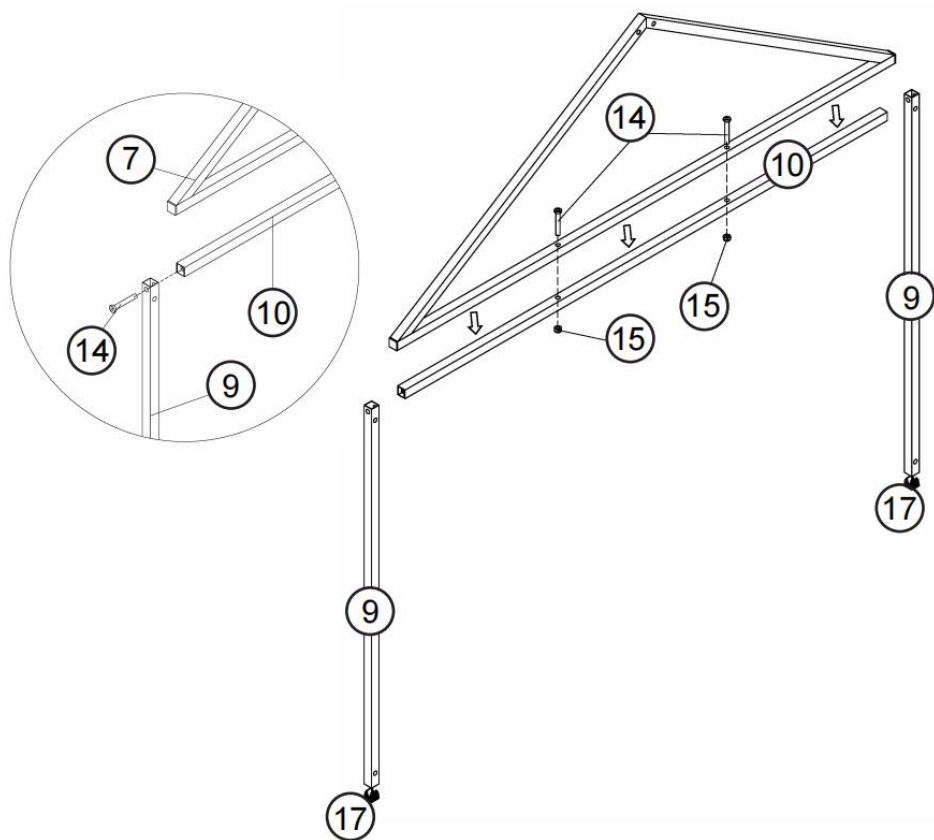

ÉTAPE 6										
	9	X4	10	X2	14	X8	15	X4	14	X4

x2

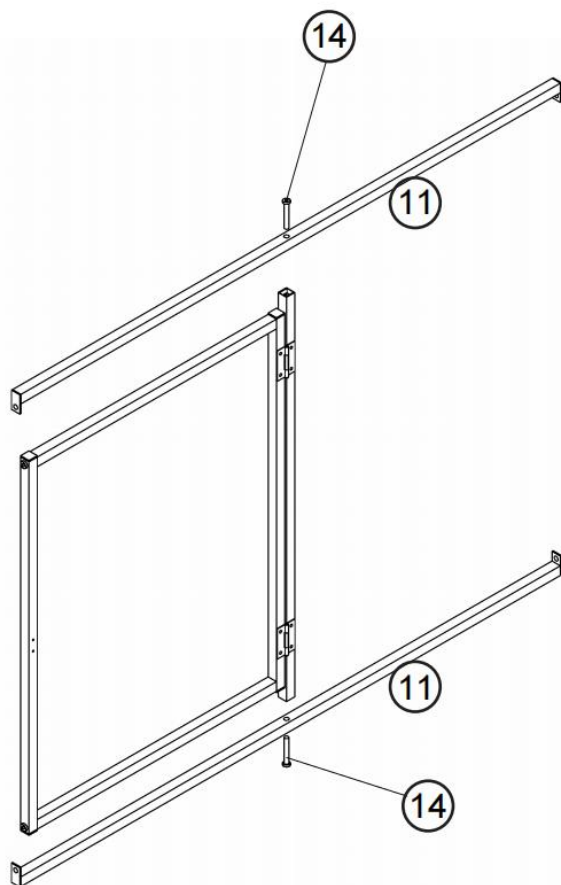
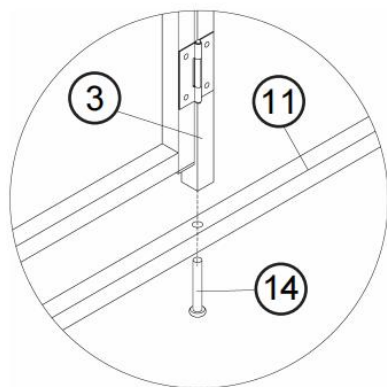



ÉTAPE 7				
	11	X2	14	X2



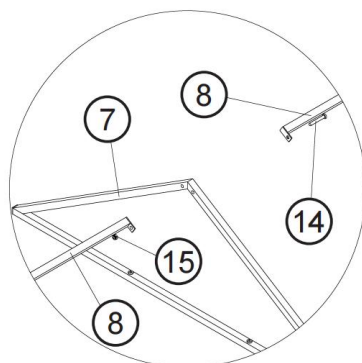
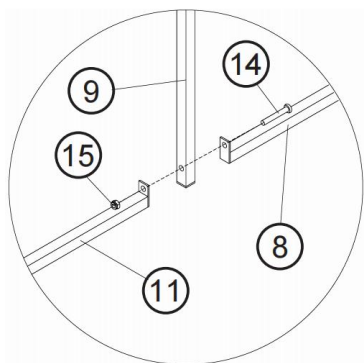
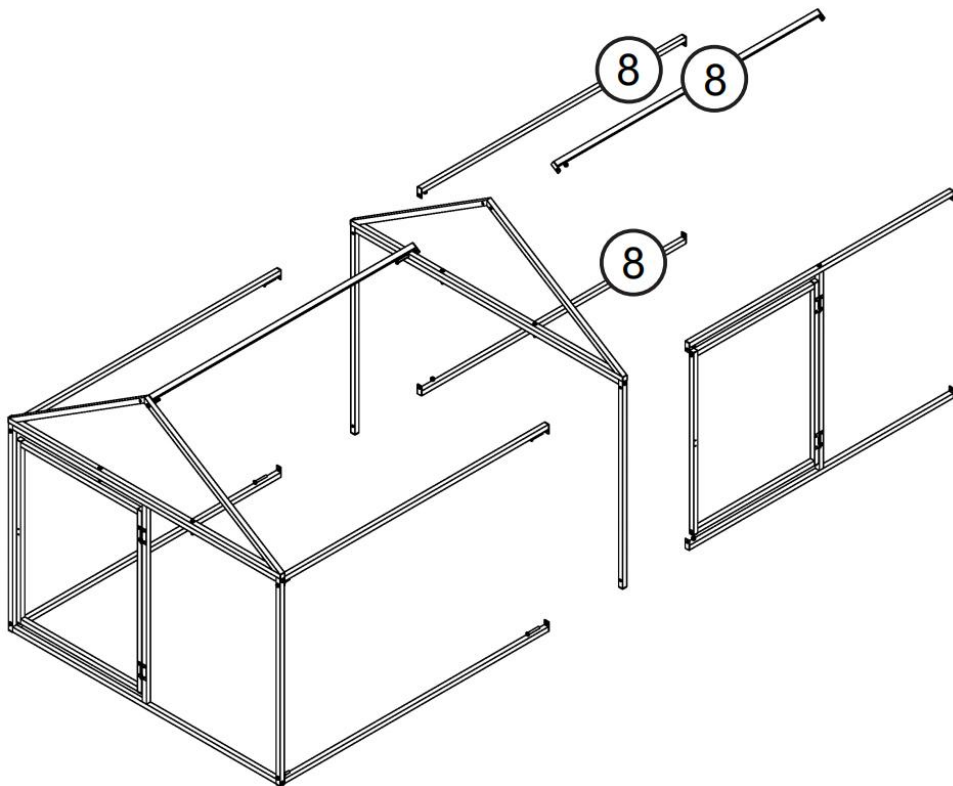

ÉTAPE 8						
	8	X3	14	X5	15	X5

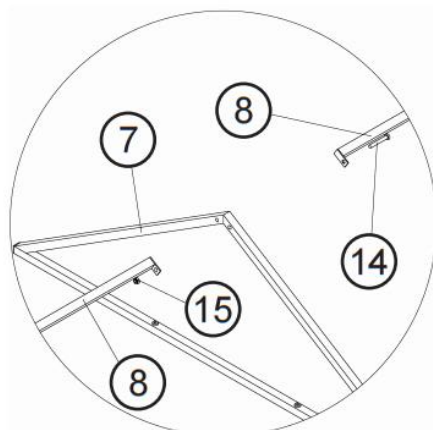
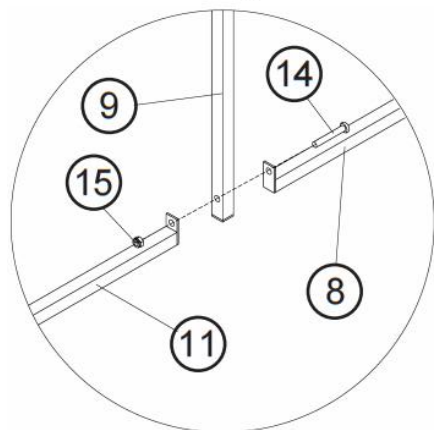
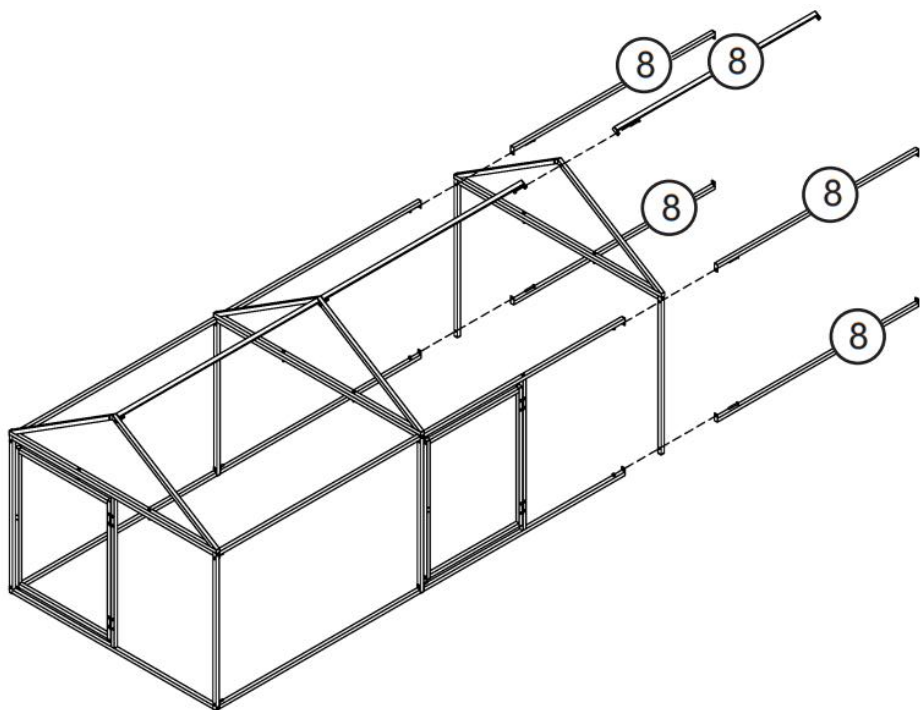

ÉTAPE 9						
	8	X5	14	X5	15	X5



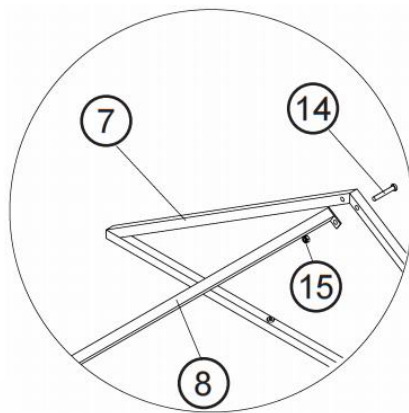
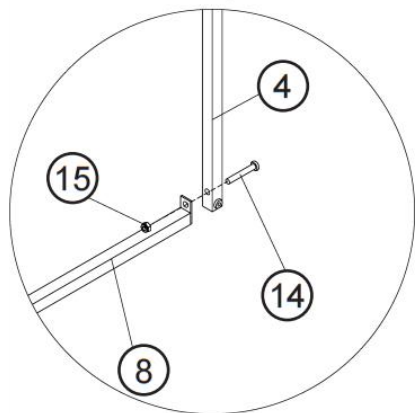
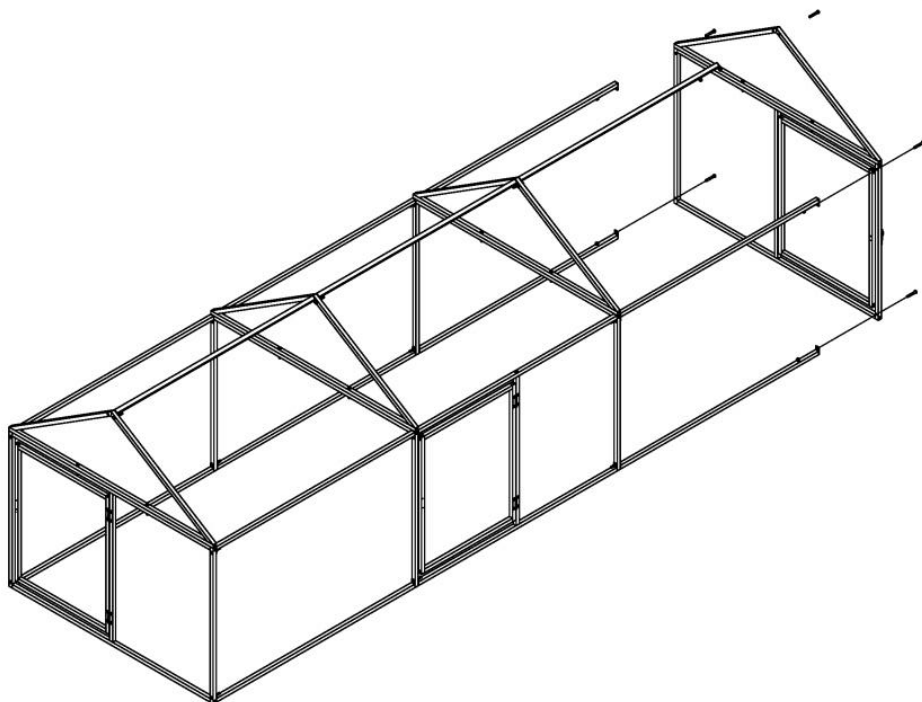

ÉTAPE 10				
	14	X5	15	X5

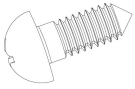

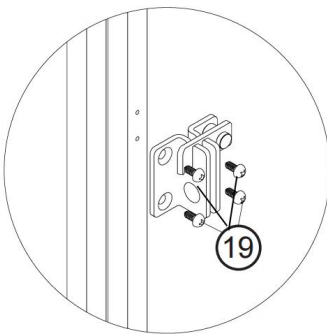
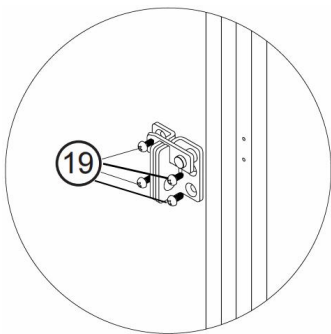
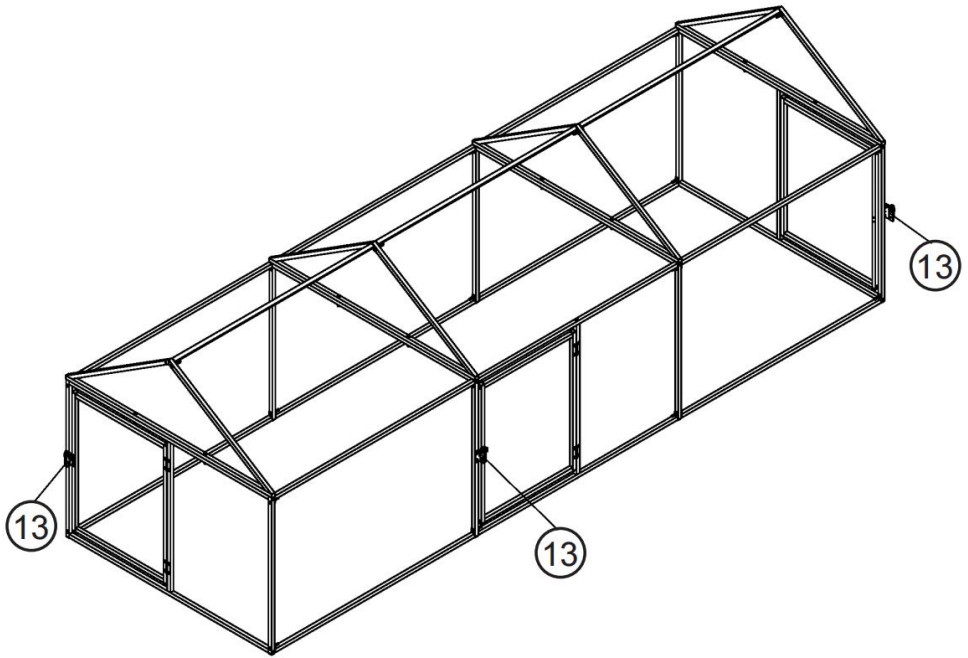
ÉTAPE 11				
	13	X3	19	X12



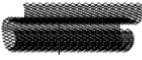

The holes for the left section needs to be drilled by yourself because the door maybe tilt after assembling due to gravity,so adjust the left section's position to make door close properly

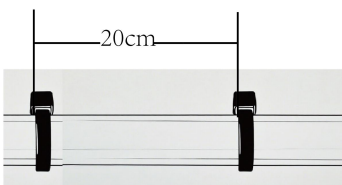
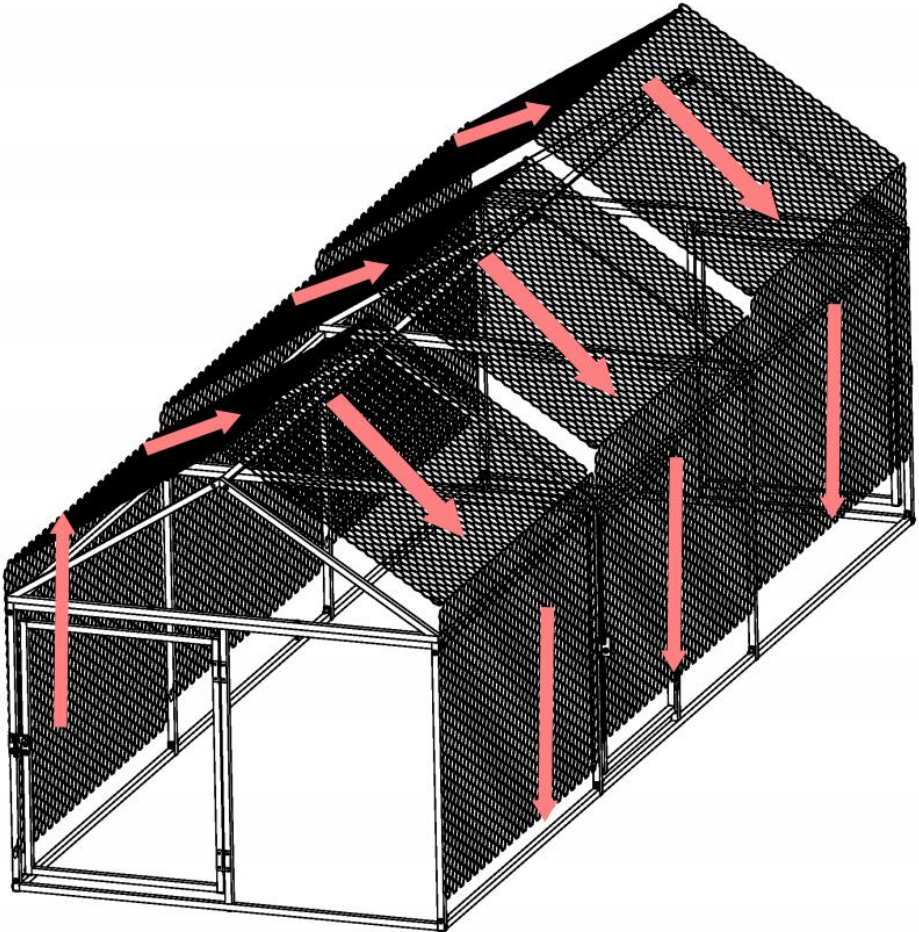
ÉTAPE 12				
	F	X1	N	X60



Use zip ties to tie the wire mesh and steel pipes together, with an interval of 20cm between each tie. Tighten the wire mesh by lowering the zip ties

ÉTAPE 13				
	F		N	X40

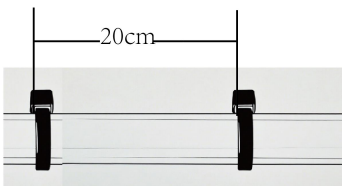
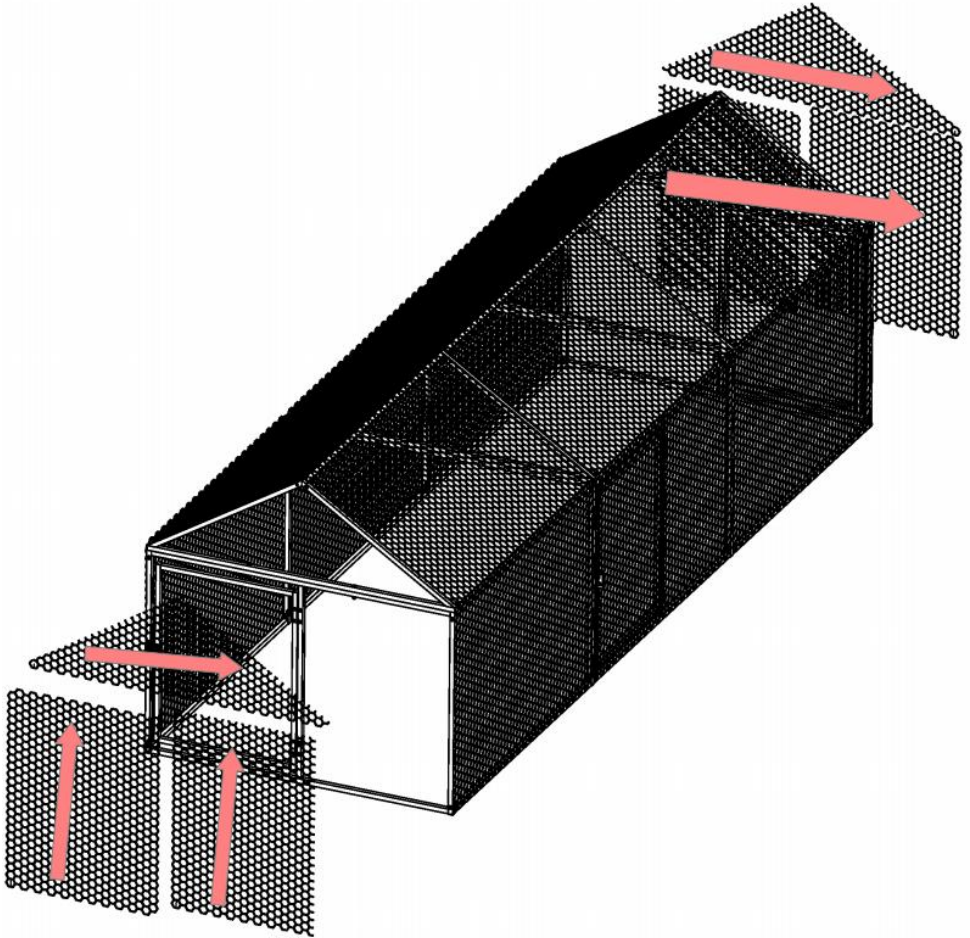

Use zip ties to tie the wire mesh and steel pipes together, with an interval of 20cm between each tie. Tighten the wire mesh by lowering the zip ties

ÉTAPE 14





16

X1

Rope on 16

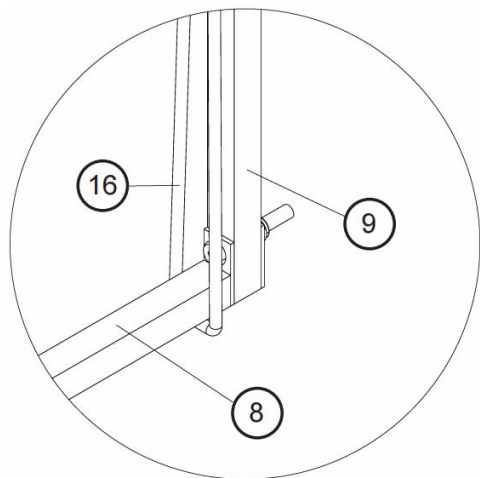
Rope on 16



ÉTAPE 15		
	20	X8

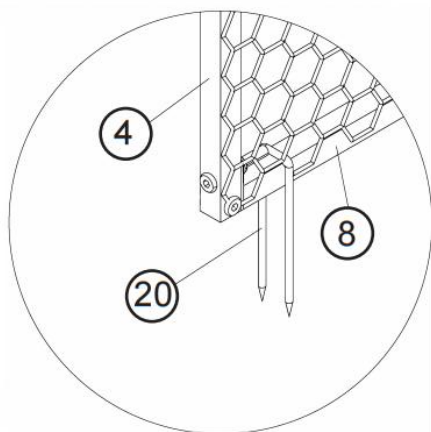
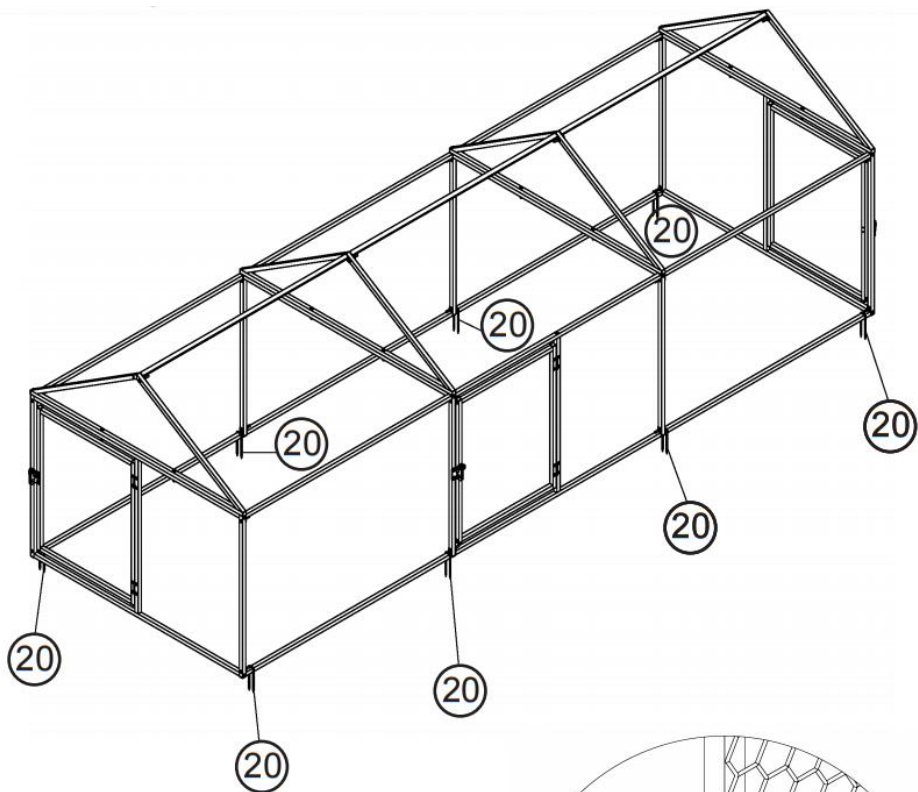

ÉTAPE 16		
	Fi l	X1

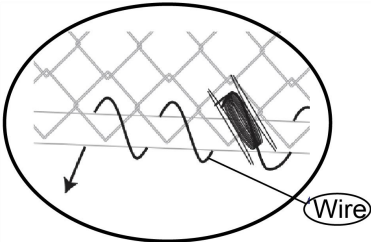
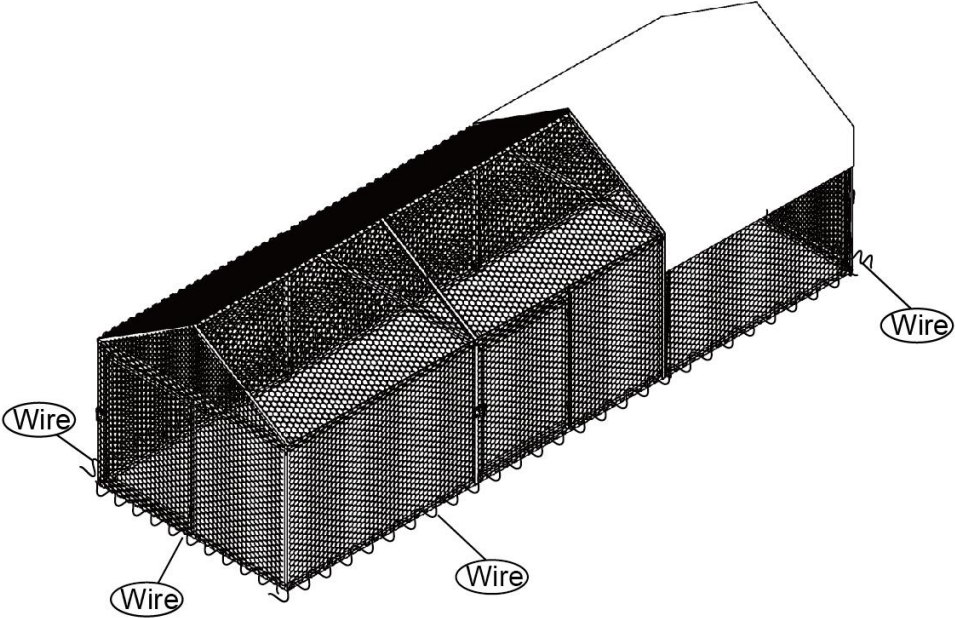

■ Note

Spiral wrap the wire at the bottom to reinforce the wire mesh and steel pipe, with a distance of 15cm between each circle. The single wire should not be wrapped more than 2 meters, and it needs to be tightened during wrapping. The knot should be firm and not loosened

PARAMÈTRE DU PRODUIT

Modèle	CRCFG0103
Couleur	Noir + Blanc
Taille du produit	3 000 × 1 000 × 1 000 mm
Matériel	Tissu Q235+PE

AVIS

Planification et sélection du site

Choisissez des zones avec un terrain élevé et un bon drainage pour éviter la rouille des pièces métalliques due à l'accumulation d'eau pendant la saison des pluies ; nivelez le site à l'avance, retirez les pierres, les mauvaises herbes et autres débris et, si nécessaire, posez des fondations en béton (en particulier pour les grands poulaillers en métal) pour améliorer la stabilité.

Contrôle des matériaux et préparation des outils

Vérifiez si la tôle, le cadre, les vis et autres accessoires sont intacts, s'il y a des déformations, de la rouille ou des dommages, et préparez des outils professionnels tels que des perceuses électriques, des clés, des rubans à mesurer, des outils de coupe (si nécessaire pour ajuster la taille de la tôle), etc.

Inspection complète après l'installation

Vérifiez la stabilité de la structure générale, l'absence de desserrage ou de déformation des planches, le bon fonctionnement des interrupteurs des portes et fenêtres et le bon fonctionnement des ouvertures de ventilation. Nettoyez régulièrement le poulailler pour éviter l'accumulation de saletés et la corrosion des pièces métalliques. Vérifiez le serrage des vis et l'intégrité des revêtements antirouille une fois par trimestre, vérifiez le serrage des filets et résolvez rapidement tout problème afin de prolonger la durée de

vie du poulailler.

Fabricant : Shanghaimuxinmuyeyouxiangongsi

Adresse : Shuangchenglu 803nong11hao1602A-1609shi, baoshanqu, Shanghai 200 000 CN.

Importé en Australie : SIHAO PTY LTD. 1 ROKEVA STREET, ASTWOOD NSW 2122 Australie

Importé aux États-Unis : Sanven Technology Ltd. Suite 250, 9166 Anaheim

Lieu, Rancho Cucamonga, CA 91730

UK	REP
-----------	------------

YH CONSULTING LIMITED. C/O YH Consulting Limited Office 147, Centurion House, London Road, Staines-upon-Thames, Surrey, TW18 4AX

EC	REP
-----------	------------

E-CrossStu GmbH
Mainzer Landstr.69,
60329 Frankfurt am Main.



VEVOR

Affordable. Reliable. Home Improvement.

HÜHNERSTALL AUS METALL

MODELL: CRCFG0103

VEVOR

Affordable. Reliable. Home Improvement.

METAL CHICKEN COOP

MODELL: CRCFG0103

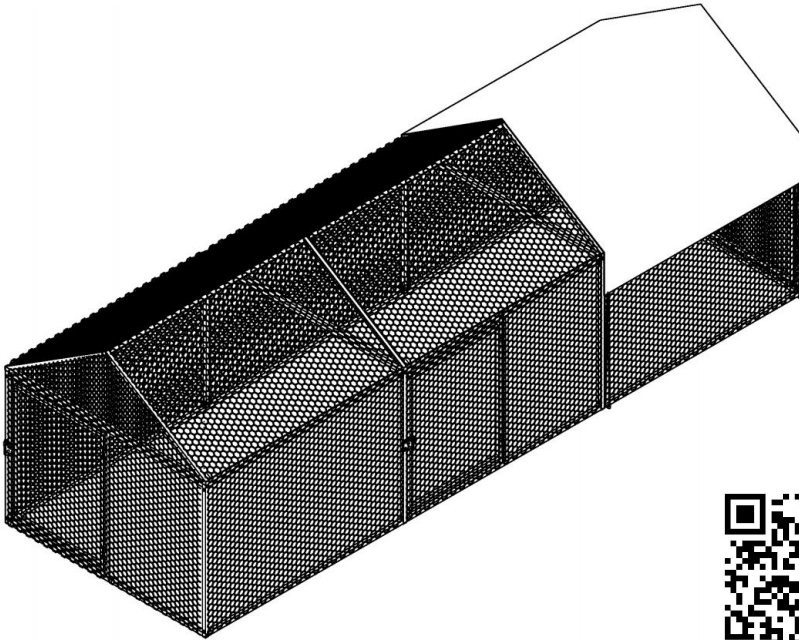

Video
installation QR

Dies ist die Originalanleitung. Bitte lesen Sie alle Anweisungen sorgfältig durch, bevor Sie das Gerät in Betrieb nehmen. VEVOR behält sich eine klare Auslegung unserer Bedienungsanleitung vor. Das Aussehen des Produkts hängt vom gelieferten Produkt ab. Bitte haben Sie Verständnis dafür, dass wir Sie nicht erneut über Technologie- oder Software-Updates informieren.

SAFETY INSTRUCTIONS

WARNUNG:

Lesen Sie dieses Material, bevor Sie dieses Produkt verwenden. Andernfalls kann es zu schweren Verletzungen kommen.

Vorsichtsmaßnahmen bei der Montage

1. Führen Sie die Montage ausschließlich gemäß dieser Anleitung durch. Eine unsachgemäße Montage kann zu Gefahren führen.
2. Tragen Sie während der Montage eine ANSI-zugelassene Schutzbrille und strapazierfähige Arbeitshandschuhe.
3. Halten Sie den Versammlungsbereich sauber und gut beleuchtet.
4. Halten Sie während der Montage unbeteiligte Personen vom Bereich fern.
5. Nicht zusammenbauen, wenn Sie müde sind oder unter dem Einfluss von Alkohol, Drogen oder Medikamenten stehen.
6. Die Produkteigenschaften gelten nur für ordnungsgemäß und vollständig montierte Produkte.
7. Weitere Informationen zu den auf den folgenden Seiten aufgeführten Teilen finden Sie im Montagediagramm dieses Handbuchs. Packen Sie alle Teile an einem sauberen Arbeitsbereich aus und trennen Sie sie.
8. Es gibt viele Produktkomponenten. Es wird empfohlen, dass zwei Personen die Installation durchführen, was die Installationszeit verkürzen kann.

Vorsichtsmaßnahmen treffen

1. SITZEN ODER STEHEN SIE NICHT AUF DIESEM ARTIKEL.
2. Dieses Produkt ist kein Spielzeug. Erlauben Sie Kindern nicht, mit diesem Artikel oder in dessen Nähe zu spielen.
3. Überschreiten Sie nicht die angegebene Gewichtskapazitäten.
4. Nur bestimmungsgemäß verwenden.
5. Vor jedem Gebrauch prüfen; nicht verwenden, wenn Teile lose oder





















beschädigt sind.

BEWAHREN SIE DIESES HANDBUCH AUF

TOOLS





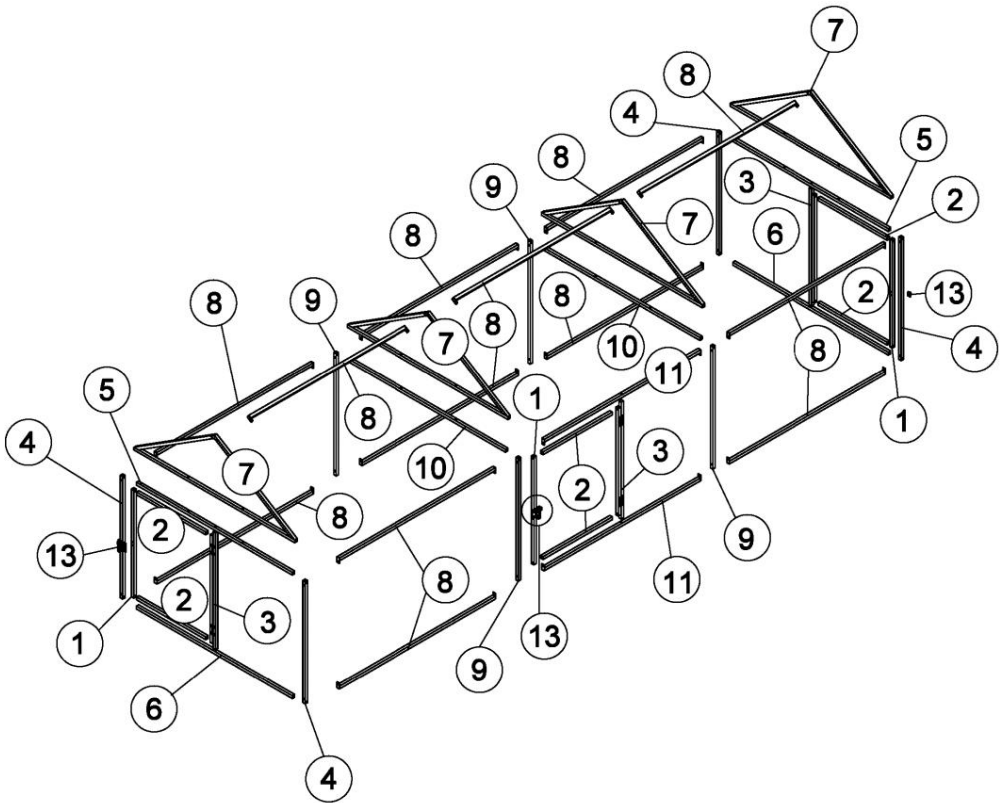

PARTS LIST

Item no.	Reference Image	Qty.	Item no.	Reference Image	Qty.
1		x3	2		x6
3		x3	4		x4
5		x2	6		x2
7		x4	8		x13
9		x4	10		x2
11		x2	13		x3
14		x58	15		x28
16		x1	17		x28
18	 1*12M	x1	19		x12
wire		x1	20		x8
21		x100			

EXPLODED VIEW



ASSEMBLY





SCHRIT T 1										
	1	X3	2	X6	3	X3	17	X12	14	X12

x3

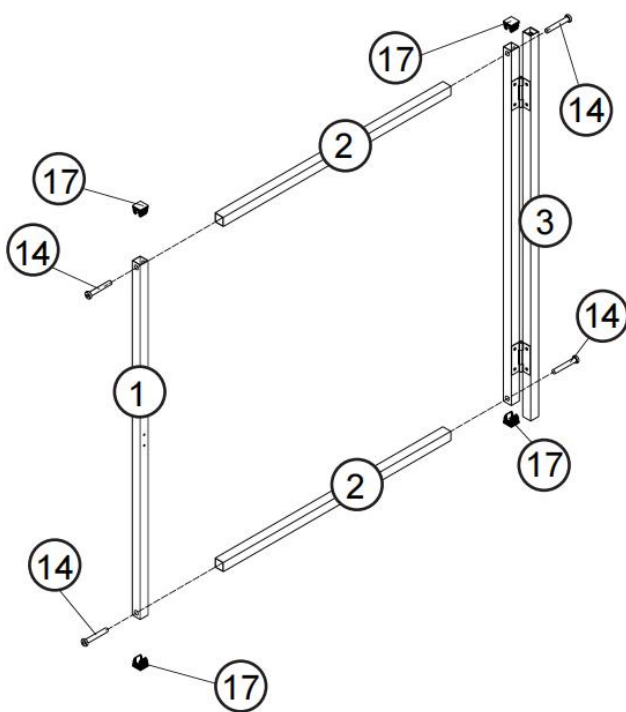
Before



After



SCHRIT T 2										
	4	X4	5	X2	6	X2	17	X4	14	X12

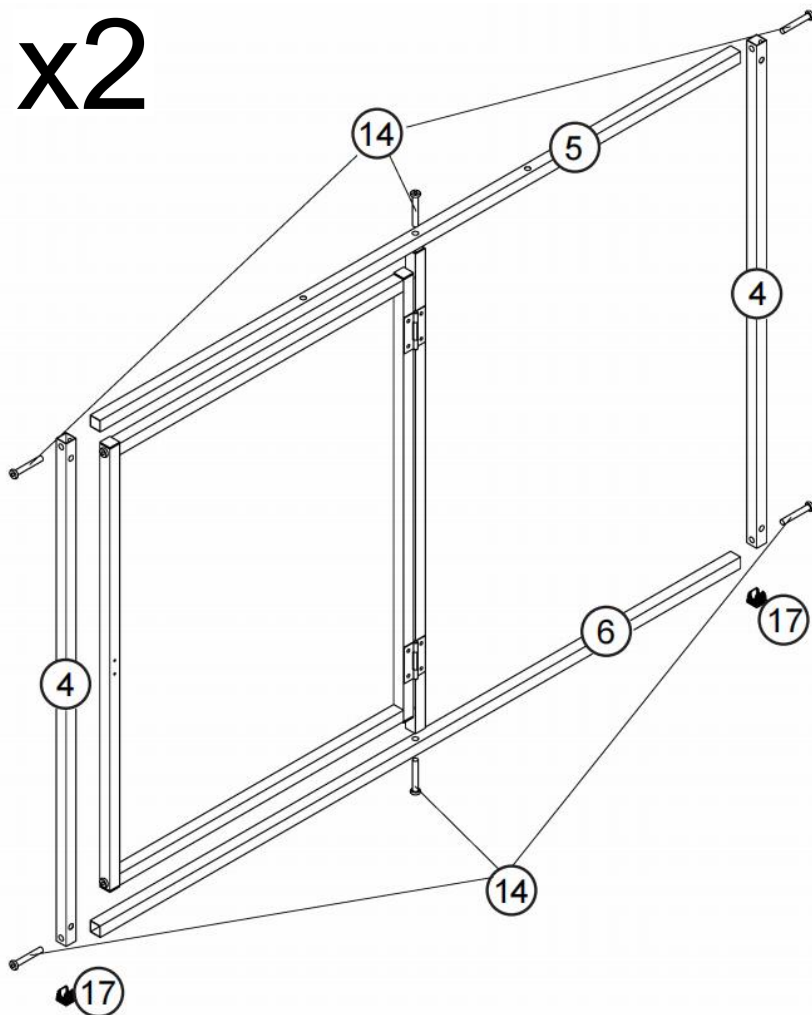

x2



SCHRITT 3				
	7	X4	17	X8

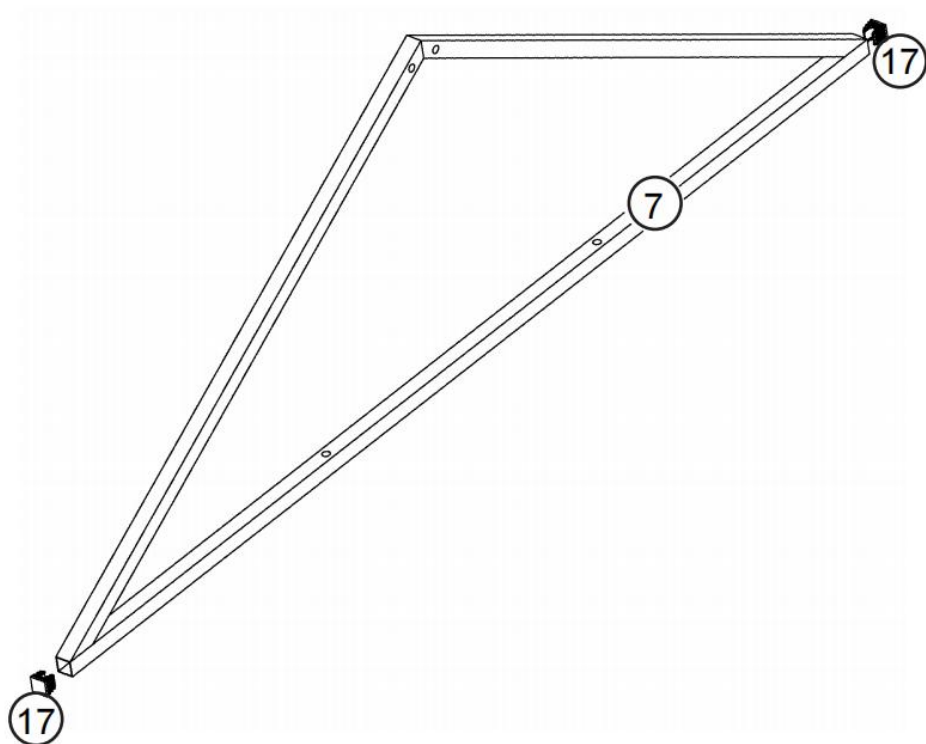

x4



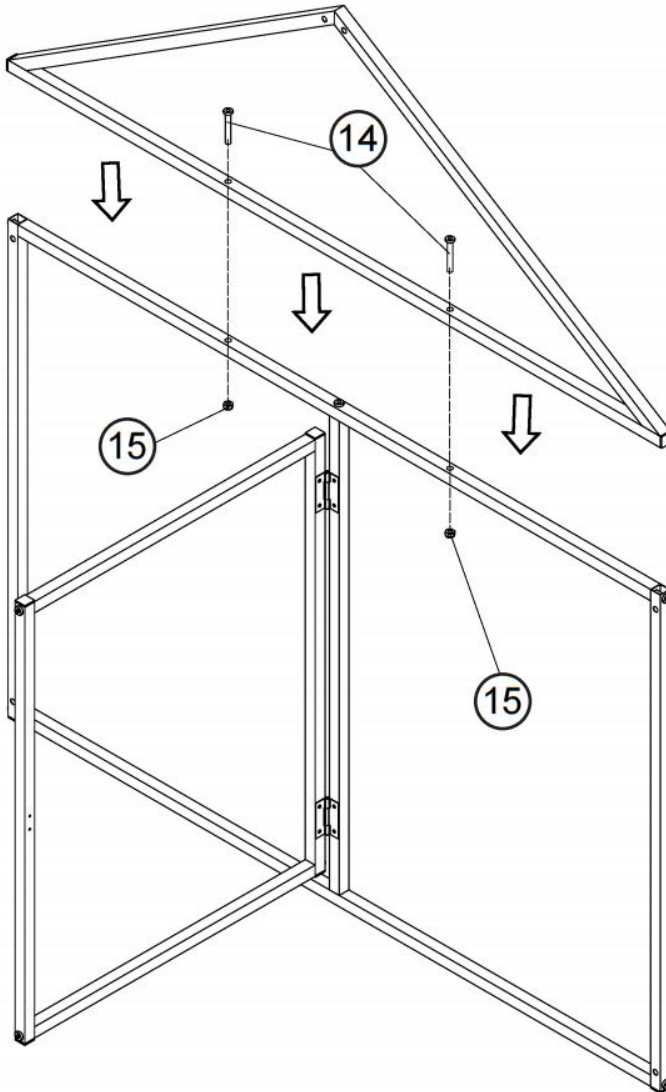

SCHRITT 4				
	14	X4	15	X4

x2



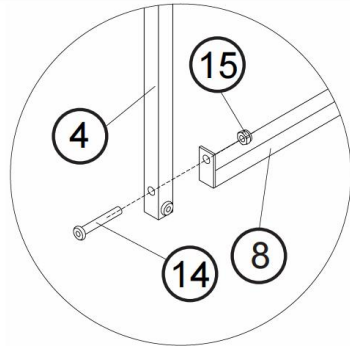
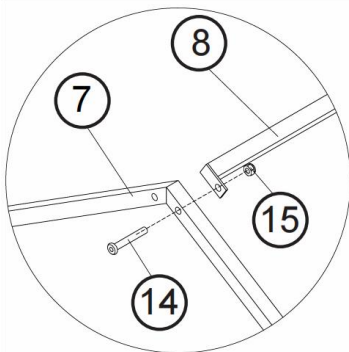
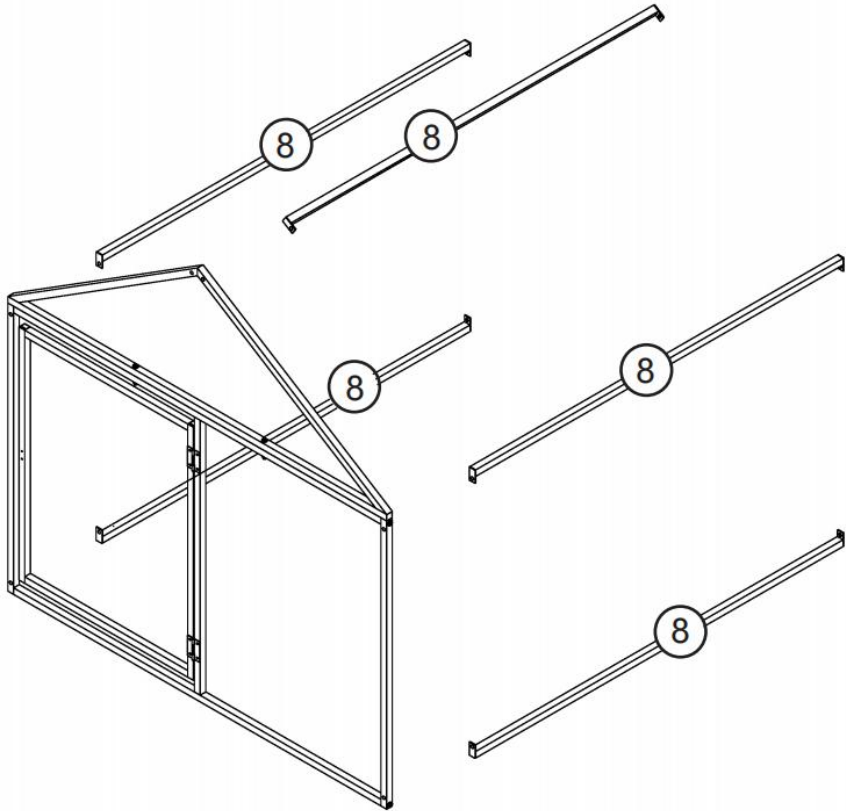

SCHRITT 5						
	8	X5	14	X5	15	X5



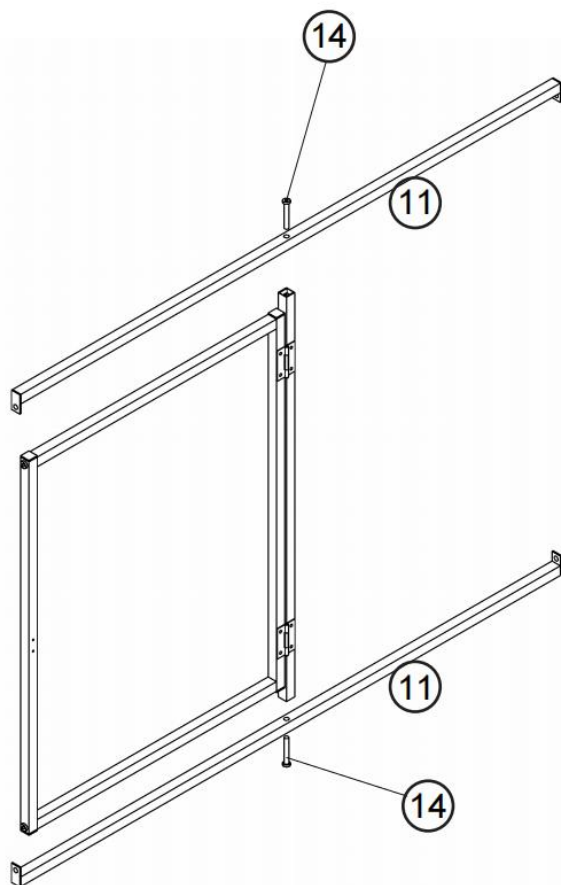
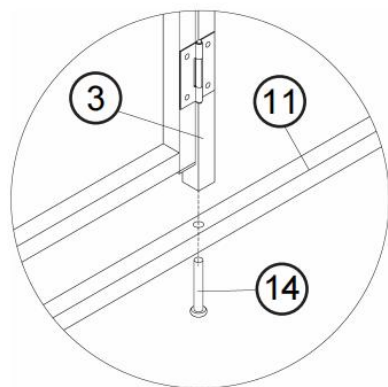

STEP 7				
	11	X2	14	X2



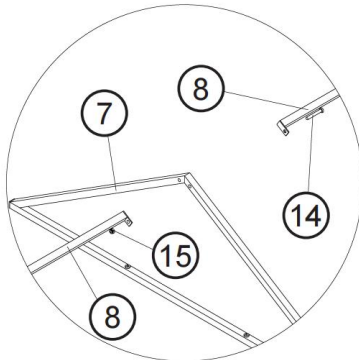
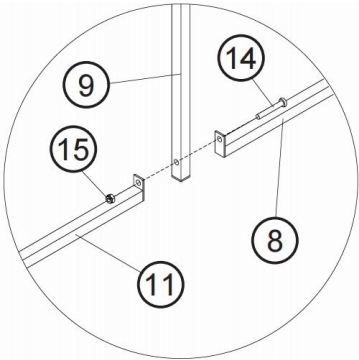
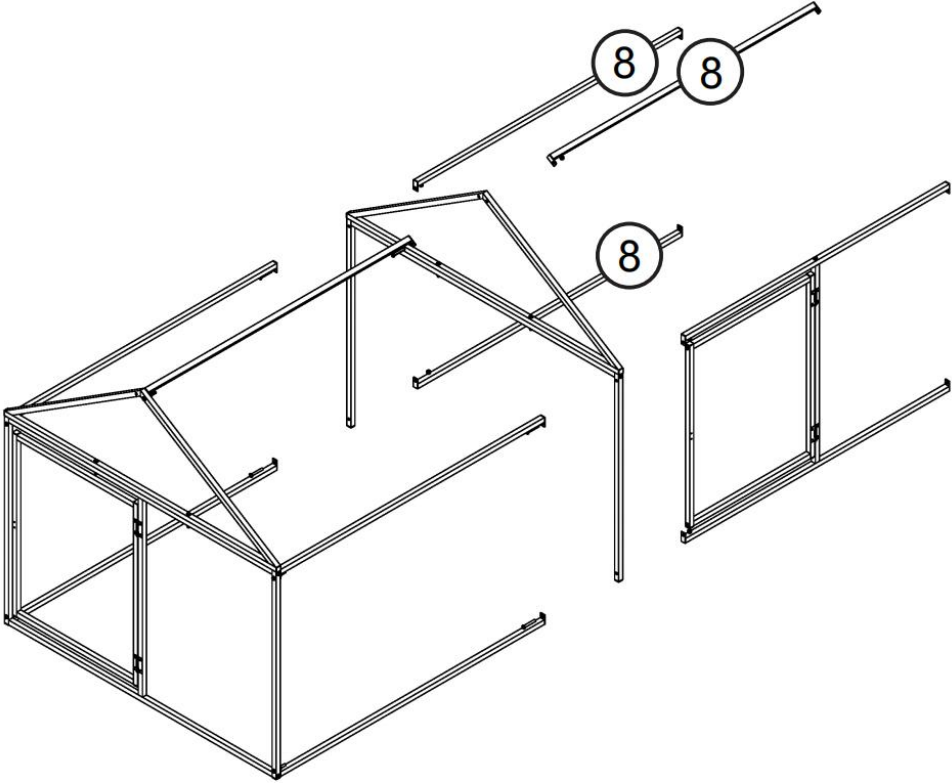

SCHRITT 8						
	8	X3	14	X5	15	X5

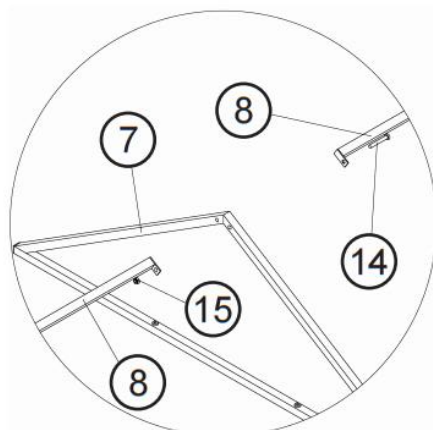
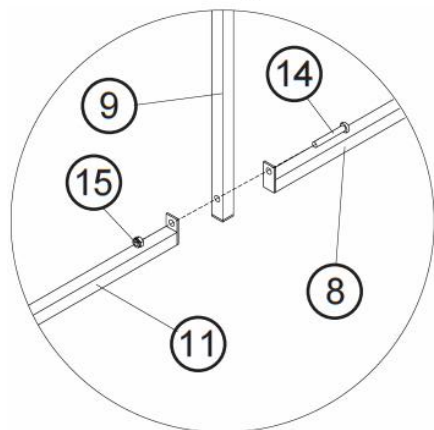
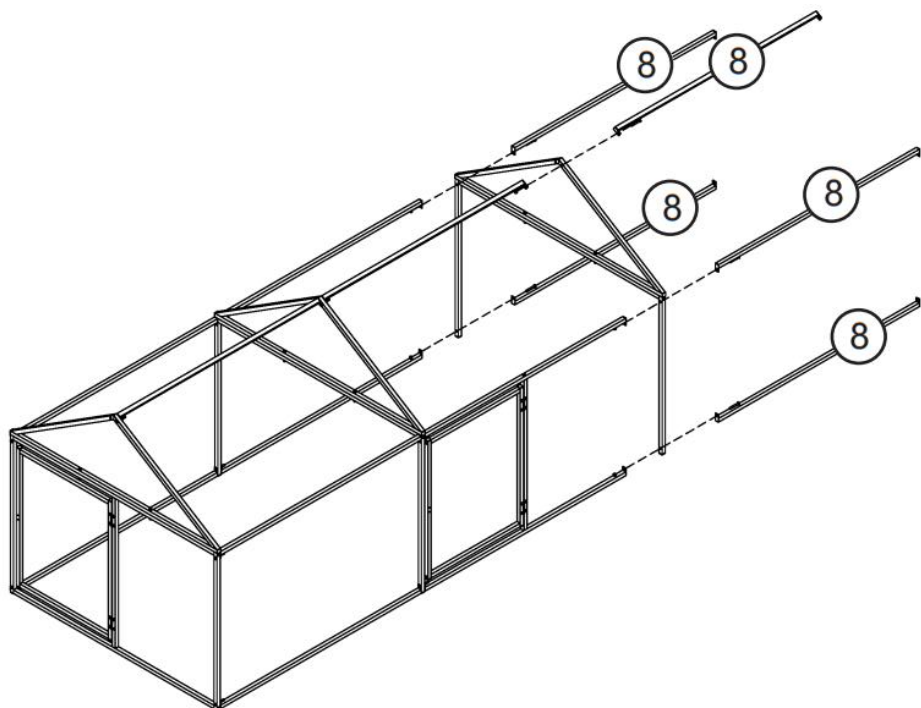

SCHRITT 9						
	8	X5	14	X5	15	X5



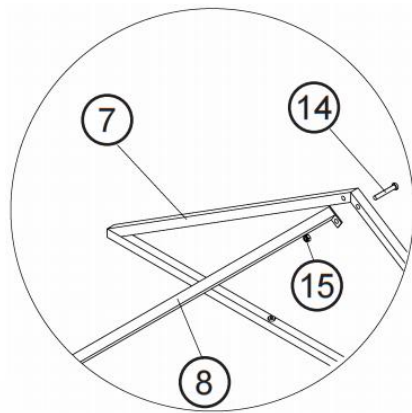
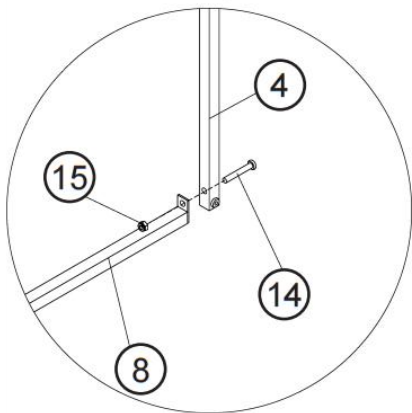
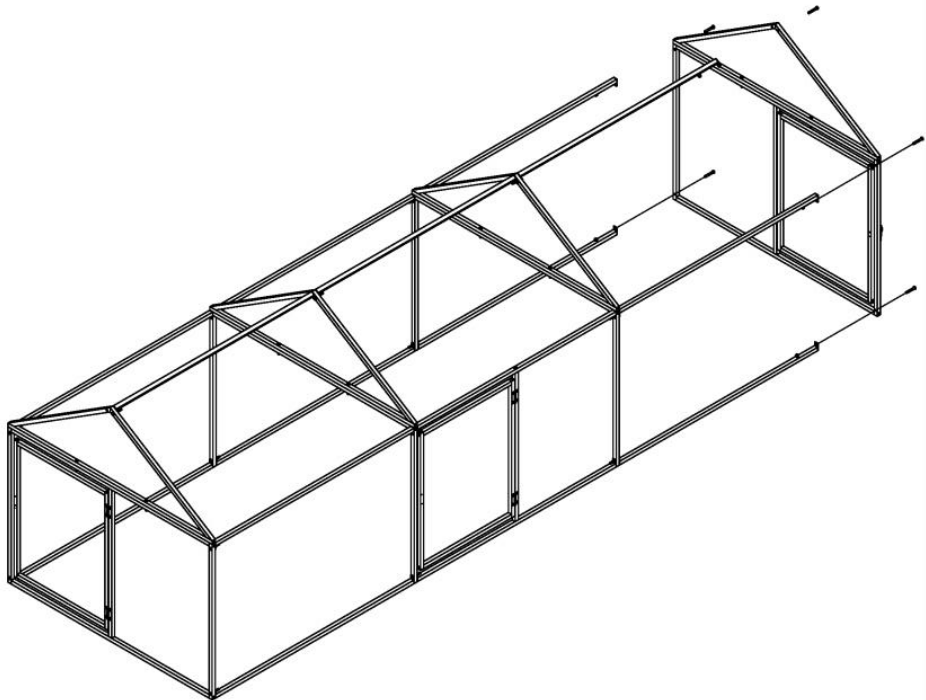

SCHRITT 10				
	14	X5	15	X5

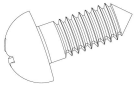

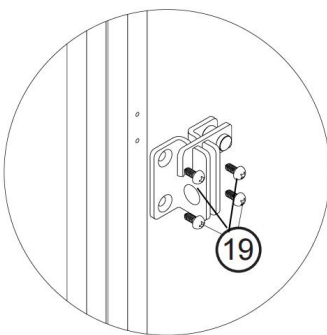
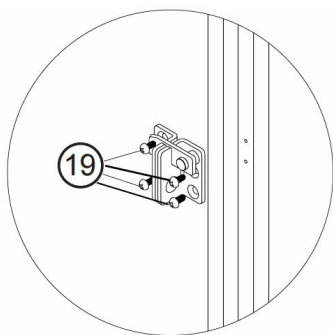
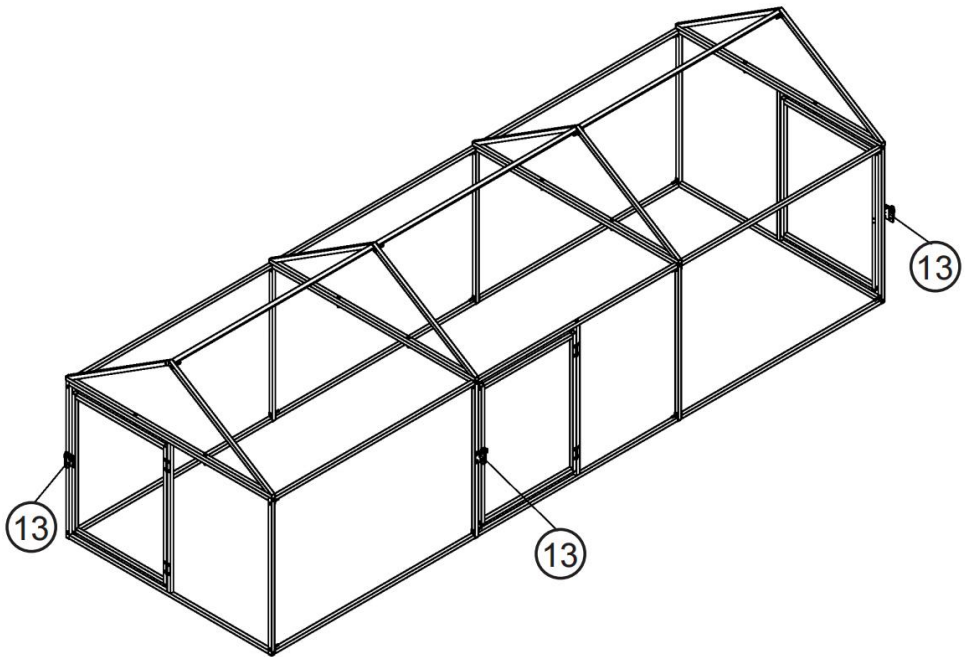
SCHRITT 11				
	13	X3	19	X12



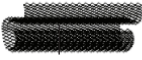

The holes for the left section needs to be drilled by yourself because the door maybe tilt after assembling due to gravity,so adjust the left section's position to make door close properly

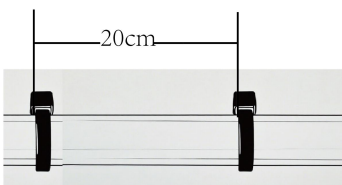
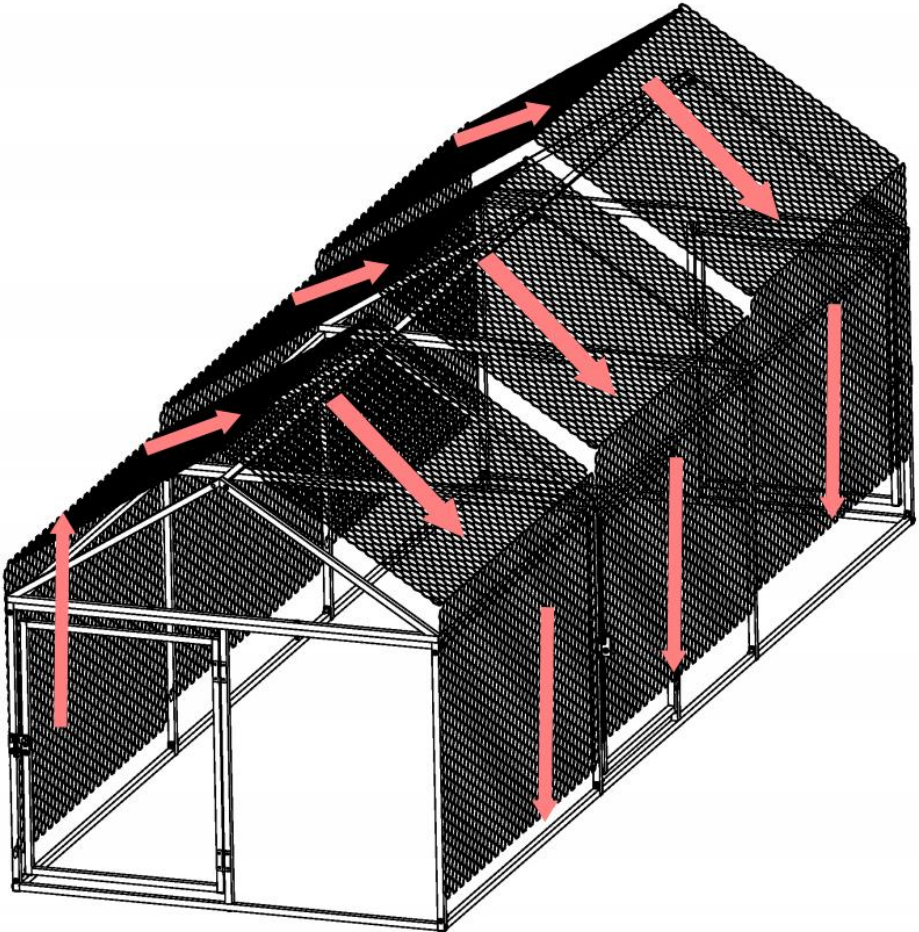
SCHRITT 12				
	F	X1	N	X60



Use zip ties to tie the wire mesh and steel pipes together, with an interval of 20cm between each tie. Tighten the wire mesh by lowering the zip ties

SCHRITT 13				
	F		N	X40

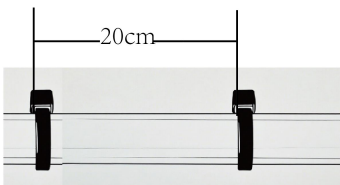
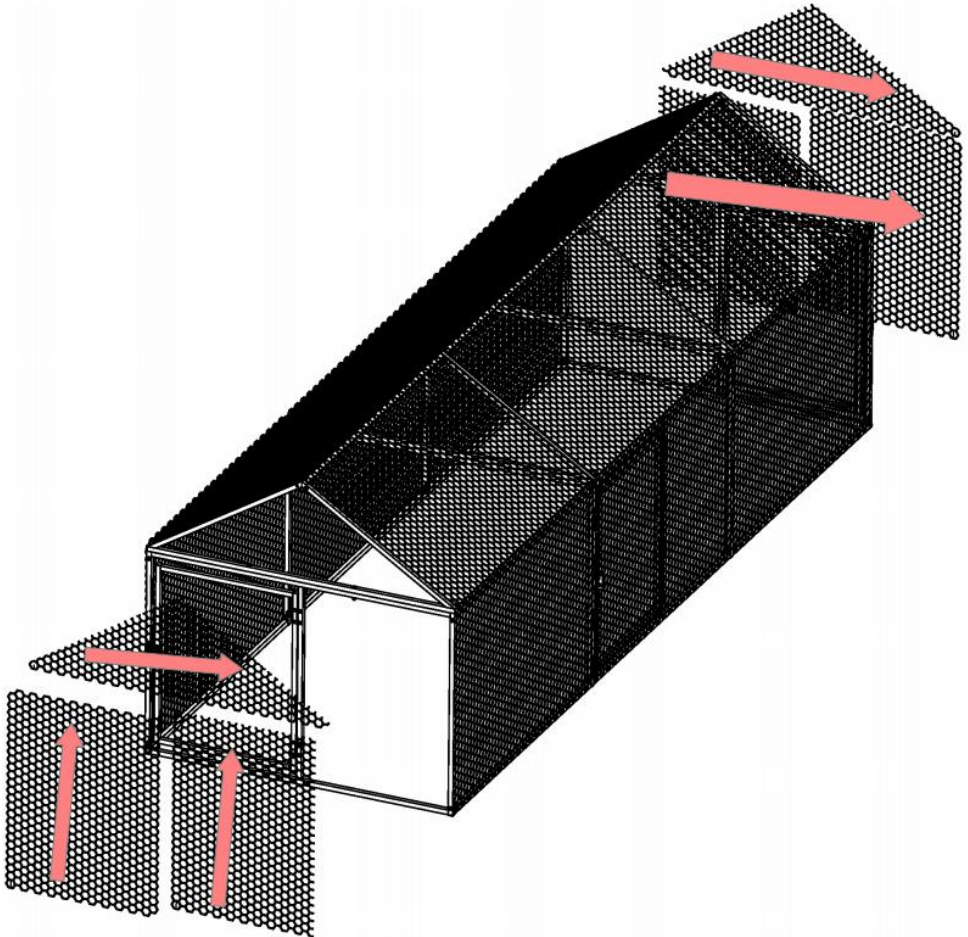

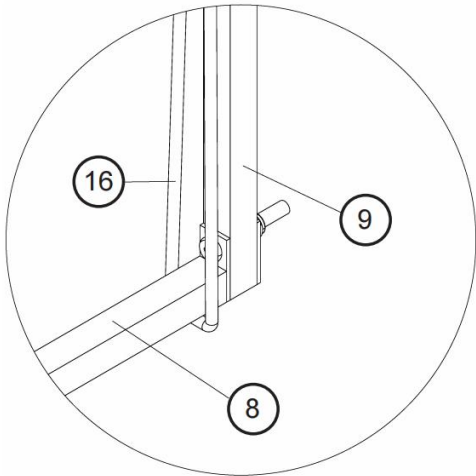
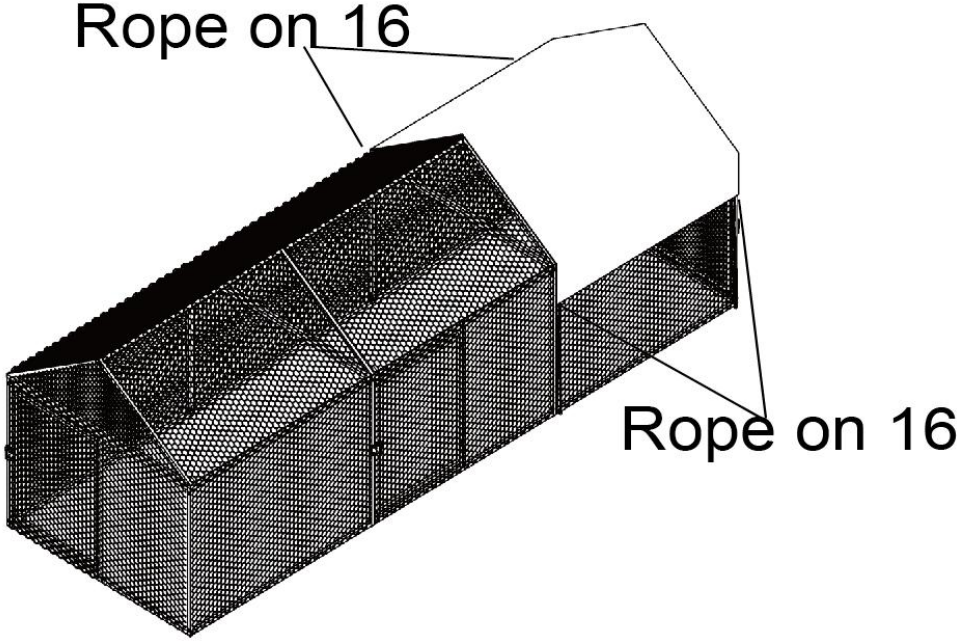

Use zip ties to tie the wire mesh and steel pipes together, with an interval of 20cm between each tie. Tighten the wire mesh by lowering the zip ties

SCHRITT 14		
	16	X1

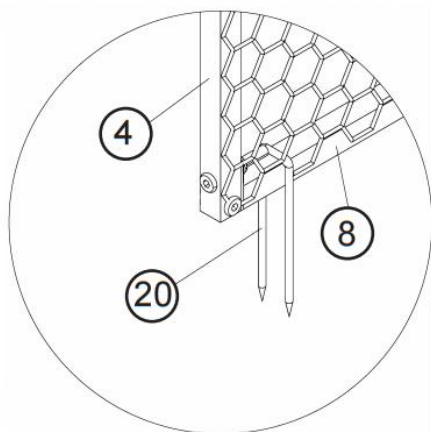
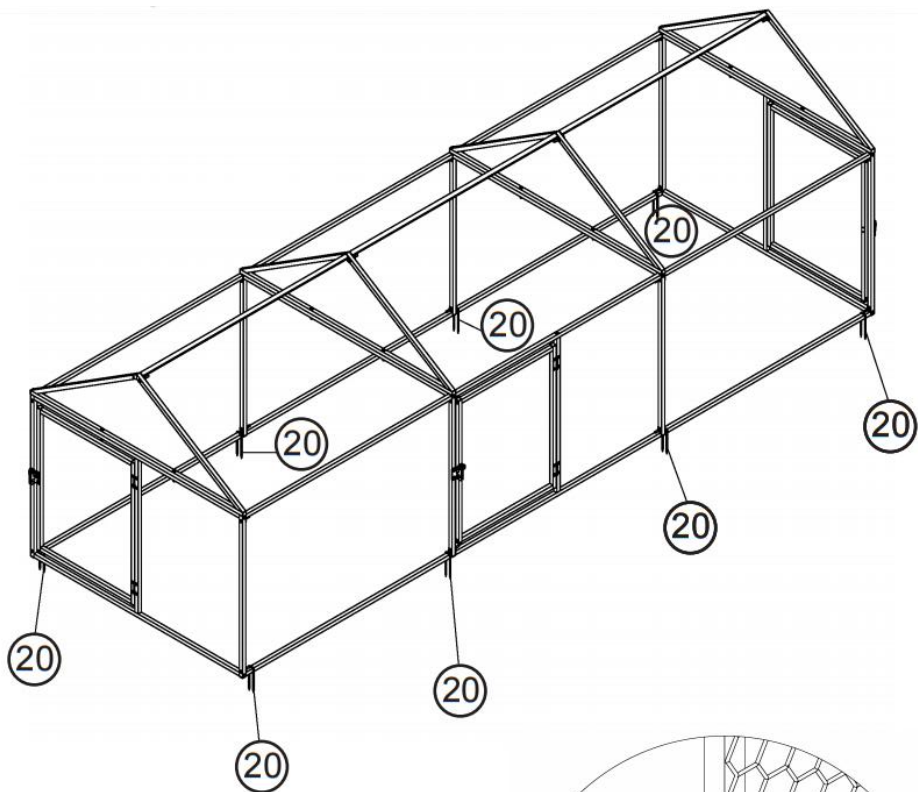

SCHRITT 15		
	20	X8



SCHRITT 16		
	Drah t	X1

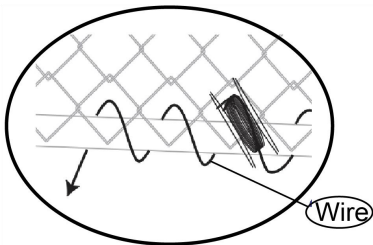
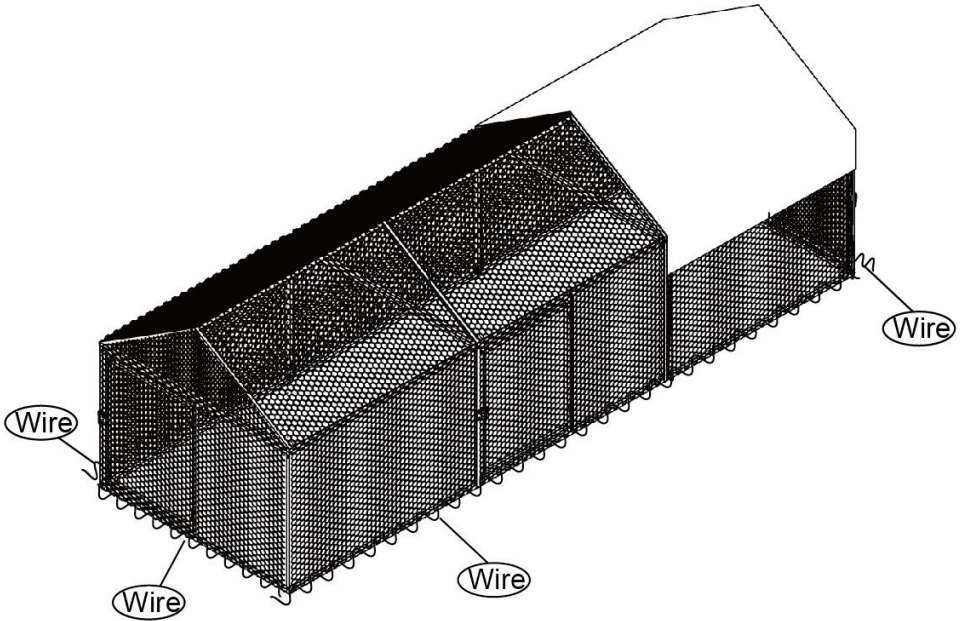

■ Note

Spiral wrap the wire at the bottom to reinforce the wire mesh and steel pipe, with a distance of 15cm between each circle. The single wire should not be wrapped more than 2 meters, and it needs to be tightened during wrapping. The knot should be firm and not loosened

PRODUKTPARAMETER

Modell	CRCFG0103
Farbe	Schwarz + Weiß
Produktgröße	3 000×1000× 1 000mm
Material	Q235+PE-Gewebe

BEACHTEN

Standortplanung und -auswahl

Wählen Sie Gebiete mit hohem Gelände und guter Drainage, um zu vermeiden, dass Metallteile durch Wasseransammlungen während der Regenzeit rosten. Einebnen Sie den Standort im Voraus, entfernen Sie Steine, Unkraut und anderen Schutt und legen Sie bei Bedarf Betonfundamente (insbesondere bei großen Hühnerställen aus Metall), um die Stabilität zu verbessern.

Materialprüfung und Werkzeugvorbereitung

Überprüfen Sie, ob Blech, Rahmen, Schrauben und sonstiges Zubehör intakt sind, ob Verformungen, Rost oder Beschädigungen vorliegen, und legen Sie professionelle Werkzeuge wie Bohrmaschinen, Schraubenschlüssel, Maßbänder, Schneidwerkzeuge (ggf. zum Anpassen der Blechgröße) usw. bereit.

Umfassende Inspektion nach der Installation

Überprüfen Sie, ob die Gesamtstruktur stabil ist, ob die Bretter locker oder verformt sind, ob die Tür- und Fensterschalter glatt sind und ob die Lüftungsöffnungen ordnungsgemäß funktionieren. Reinigen Sie den Hühnerstall regelmäßig von Kot und Schmutz, um zu verhindern, dass sich Schmutz an den Metallteilen ansammelt. Überprüfen Sie vierteljährlich den festen Sitz der Schrauben und die Unversehrtheit der Rostschutzbeschichtungen. Überprüfen Sie die Netzbindung auf

Lockerheit und beheben Sie auftretende Probleme umgehend, um die Lebensdauer des Hühnerstalls zu verlängern.

Hersteller: Shanghaimuxinmuyeyouxiangongsi

Adresse: Shuangchenglu 803nong11hao1602A-1609shi, baoshanqu, Shanghai 200000 CN.

Importiert nach AUS: SIHAO PTY LTD. 1 ROKEVA STREETEASTWOOD NSW 2122 Australien

Importiert in die USA: Sanven Technology Ltd. Suite 250, 9166 Anaheim Place, Rancho Cucamonga, CA 91730

UK	REP
-----------	------------

YH CONSULTING LIMITED. C/O YH Consulting Limited Office 147, Centurion House, London Road, Staines-upon-Thames, Surrey, TW18 4AX

EC	REP
-----------	------------

E-CrossStu GmbH
Mainzer Landstr.69,
60329 Frankfurt am Main.



VEVOR

Affordable. Reliable. Home Improvement.

METALOWY KURNIK

MODEL: CRCFG0103

VEVOR

Affordable. Reliable. Home Improvement.

METAL CHICKEN COOP

MODEL: CRCFG0103

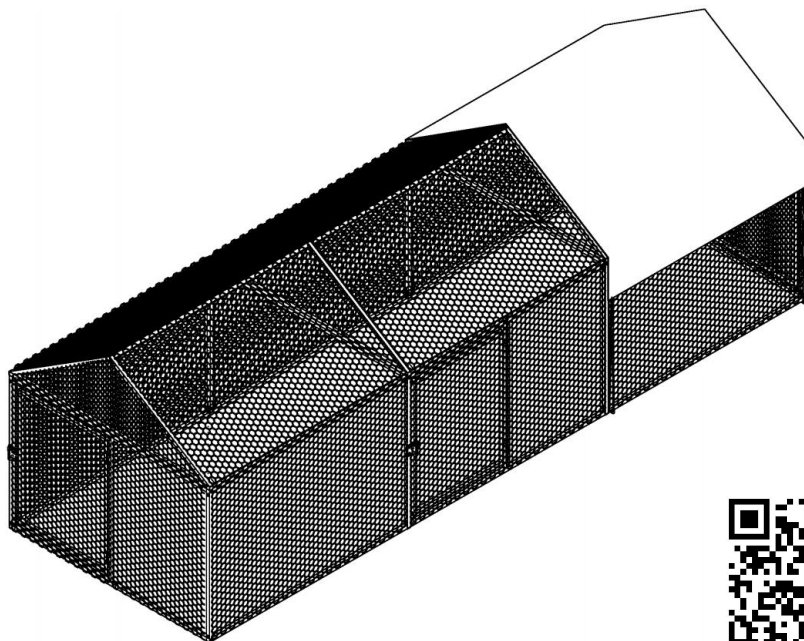

Video
installation QR

To jest oryginalna instrukcja obsługi. Przed użyciem prosimy o dokładne zapoznanie się z treścią instrukcji. Firma VEVOR zastrzega sobie prawo do jednoznacznej interpretacji niniejszej instrukcji obsługi. Wygląd produktu zależy od stanu, w jakim go otrzymali Państwo. Prosimy o wyrozumiałość, ale nie będziemy Państwa ponownie informować o aktualizacjach technologicznych lub oprogramowania naszego produktu.

SAFETY INSTRUCTIONS

OSTRZEŻENIE:

Przeczytaj ten materiał przed użyciem produktu. Nieprzestrzeganie tego zalecenia może spowodować poważne obrażenia.

Środki ostrożności podczas montażu

1. Montaż należy wykonywać wyłącznie zgodnie z niniejszą instrukcją. Nieprawidłowy montaż może stwarzać zagrożenie.
2. Podczas montażu należy nosić okulary ochronne zatwierdzone przez ANSI oraz wytrzymałe rękawice robocze.
3. Utrzymuj miejsce zgromadzenia w czystości i zapewnij dobre oświetlenie.
4. Nie dopuszczaj osób postronnych na teren montażu w trakcie jego trwania.
5. Nie przychodź na zgromadzenie, jeśli jesteś zmęczony lub pod wpływem alkoholu, narkotyków lub leków.
6. Możliwości produktu odnoszą się wyłącznie do produktów prawidłowo i całkowicie zmontowanych.
7. Aby uzyskać dodatkowe informacje dotyczące części wymienionych na kolejnych stronach, zapoznaj się ze schematem montażu w niniejszej instrukcji. Rozpakuj i rozdziel wszystkie części w czystym miejscu pracy.
8. Produkt składa się z wielu komponentów. Zaleca się, aby montaż wykonały dwie osoby, co może skrócić czas instalacji.

Zachowaj środki ostrożności

1. NIE WOLNO SIEDZIEĆ ANI STAWAĆ NA TYM PRZEDMIOCIE.
2. Ten produkt nie jest zabawką. Nie pozwalaj dzieciom bawić się nim ani przebywać w jego pobliżu.
3. Nie przekraczać określonej wartości nośności.
4. Stosować wyłącznie zgodnie z przeznaczeniem.
5. Przed każdym użyciem należy przeprowadzić kontrolę. Nie używać

produktu, jeśli części są luźne lub uszkodzone.

ZAPISZ TĘ INSTRUKCJĘ

TOOLS





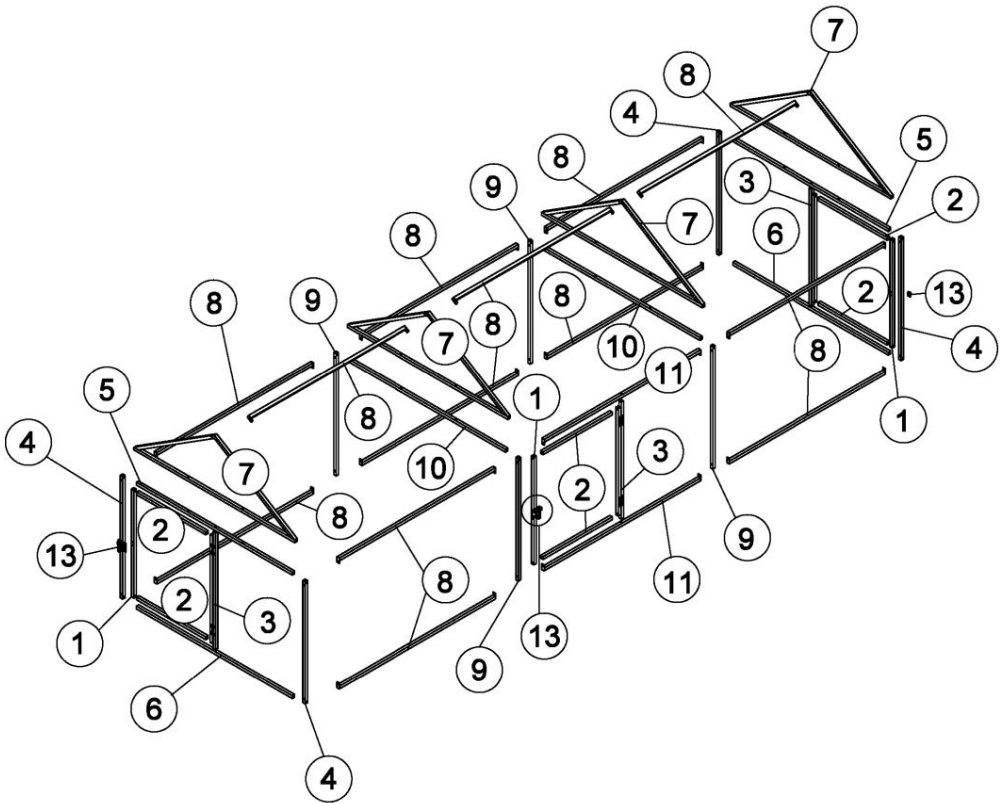

PARTS LIST

Item no.	Reference Image	Qty.	Item no.	Reference Image	Qty.
1		x3	2		x6
3		x3	4		x4
5		x2	6		x2
7		x4	8		x13
9		x4	10		x2
11		x2	13		x3
14		x58	15		x28
16		x1	17		x28
18	 1*12M	x1	19		x12
wire		x1	20		x8
21		x100			

EXPLODED VIEW



ASSEMBLY

KROK 1										
	1	X3	2	X6	3	X3	17	X12	14	X12





x3

Before

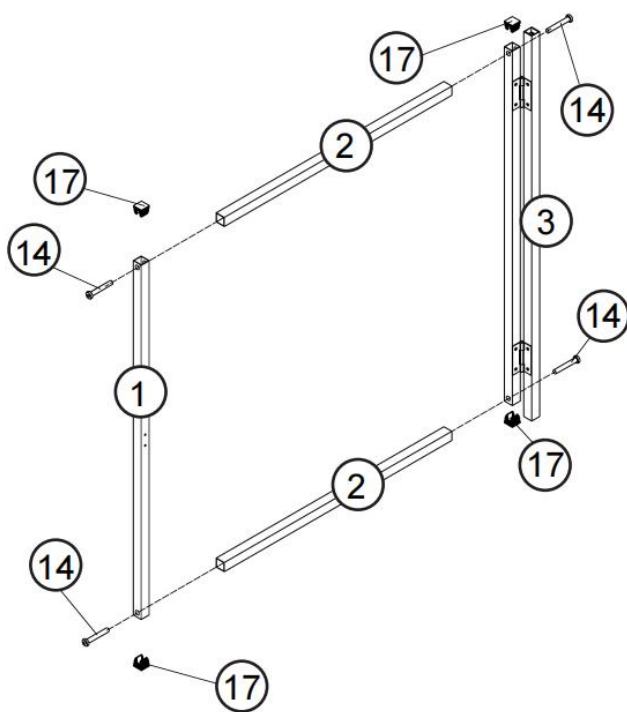



After



KROK 2										
	4	X4	5	X2	6	X2	17	X4	14	X12

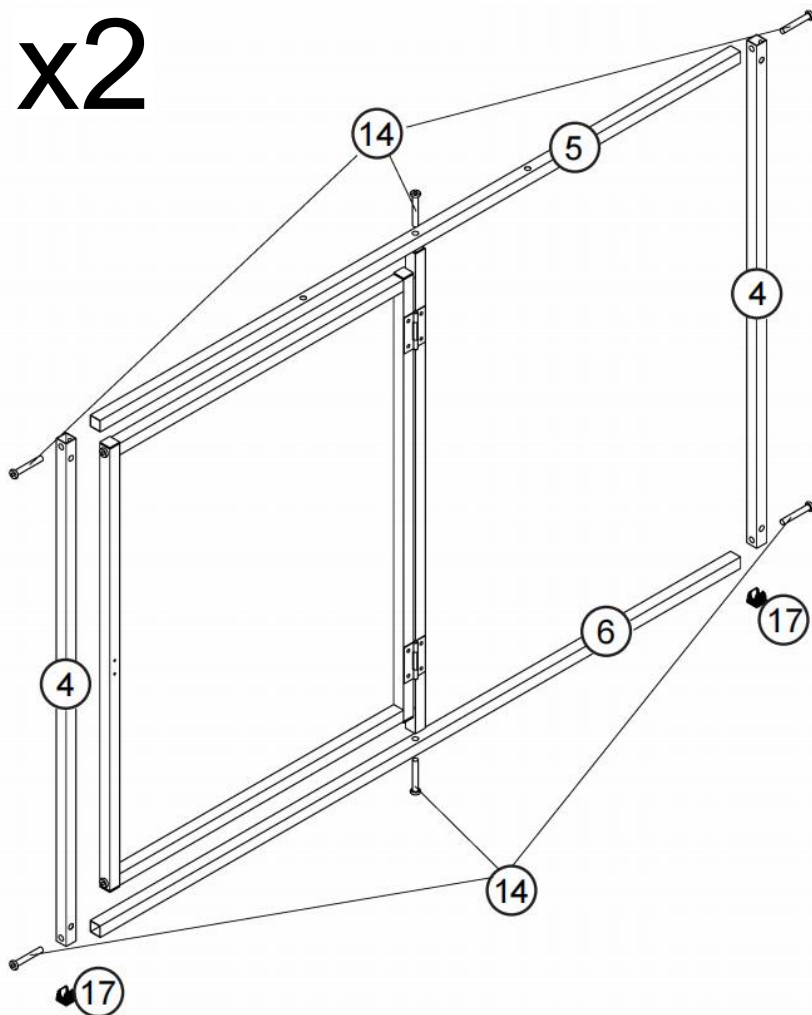

x2



KROK 3				
	7	X4	17	X8

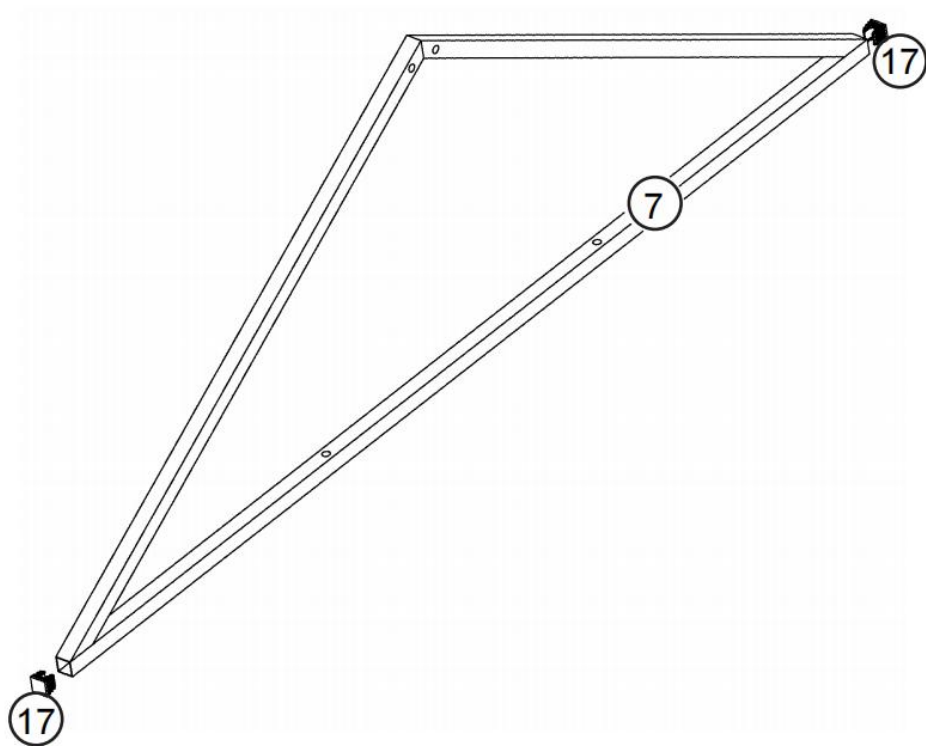

x4





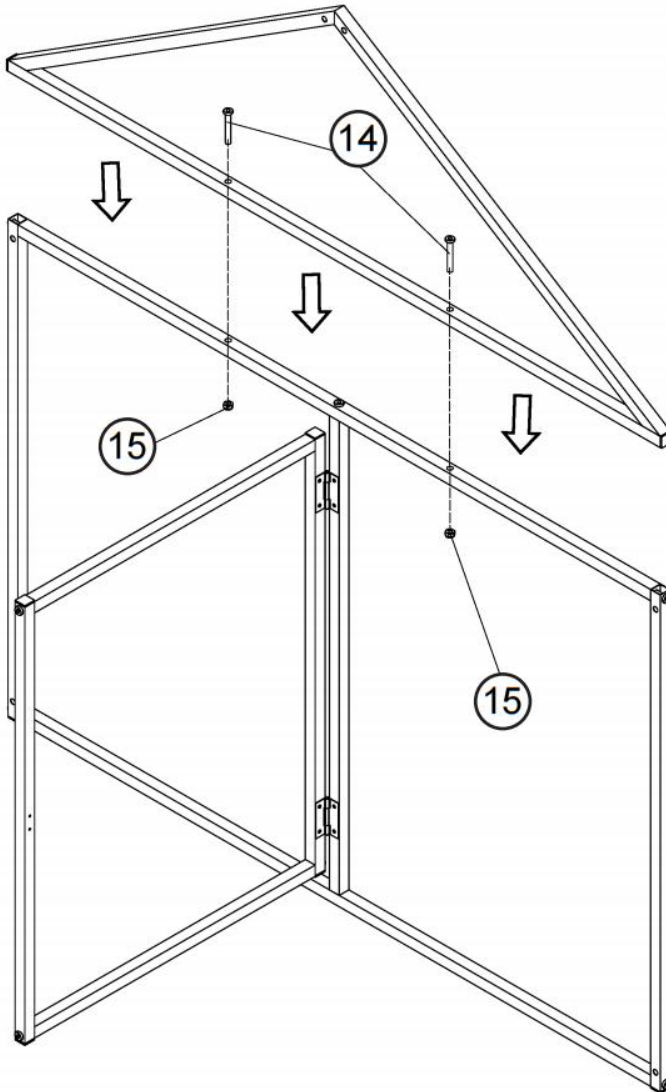

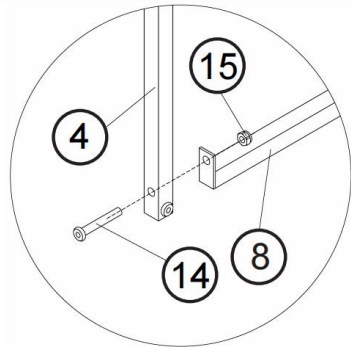
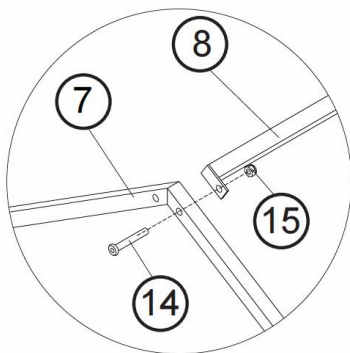
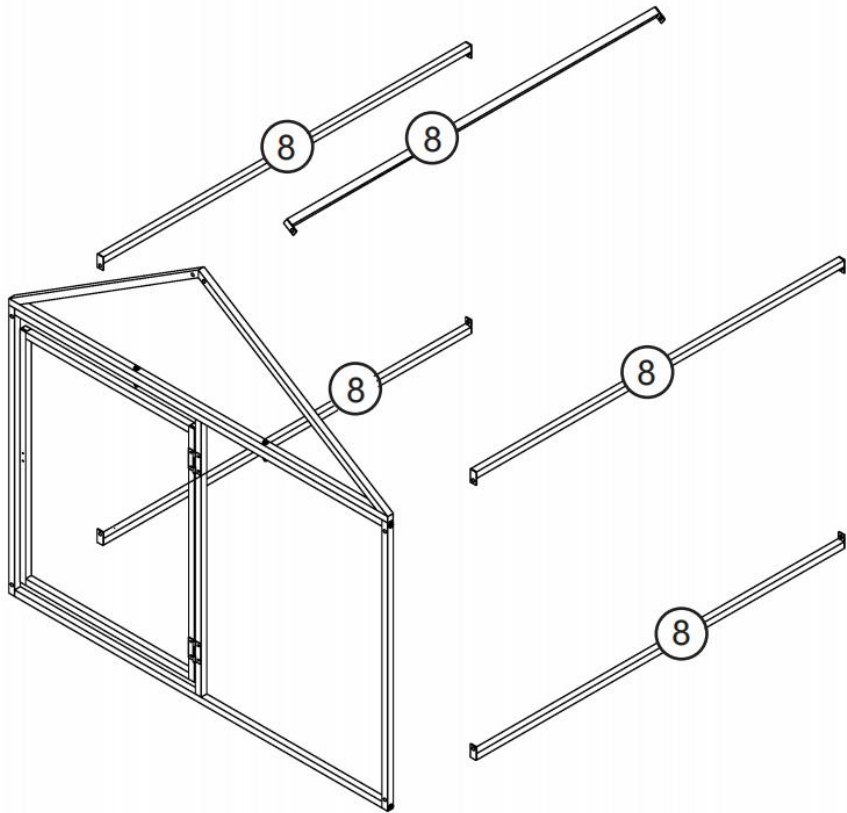

KROK 4				
	14	X4	15	X4

x2





KROK 5						
	8	X5	14	X5	15	X5





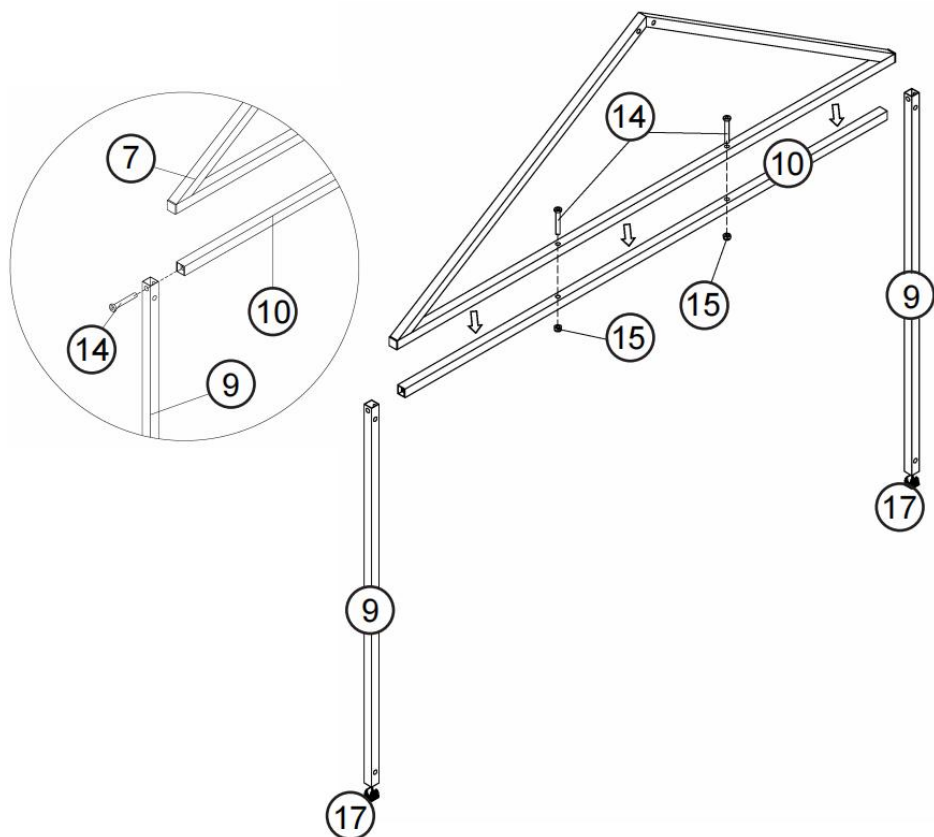

KROK 6										
	9	X4	10	X2	14	X8	15	X4	14	X4

x2

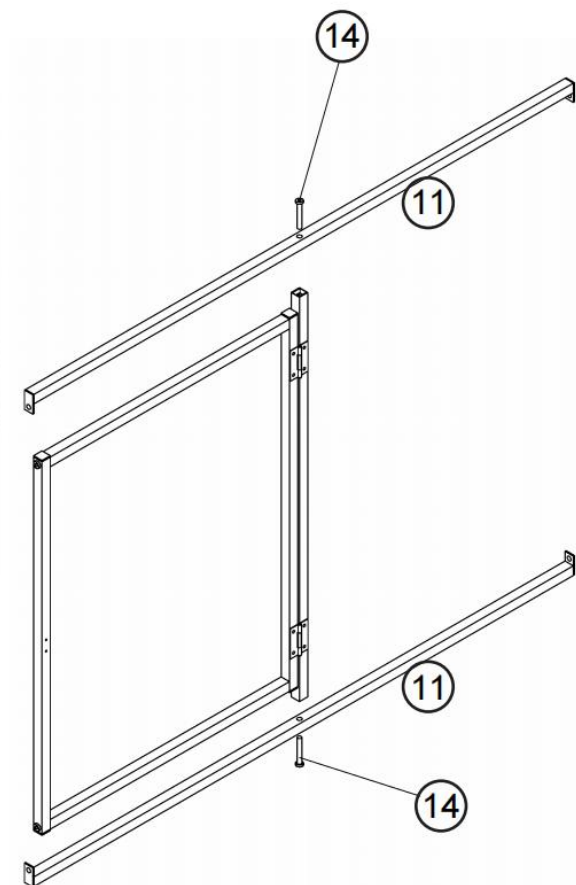
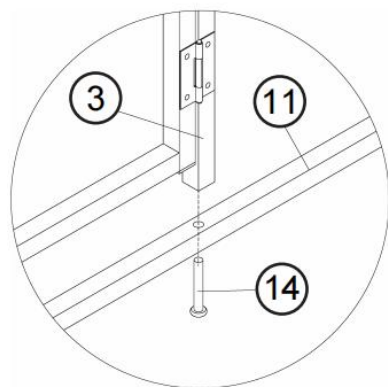



KROK 7				
	11	X2	14	X2



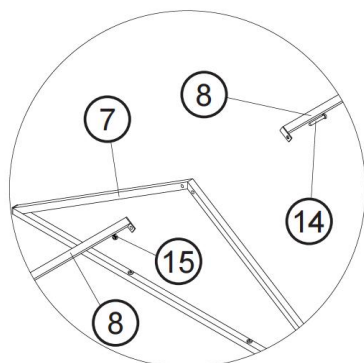
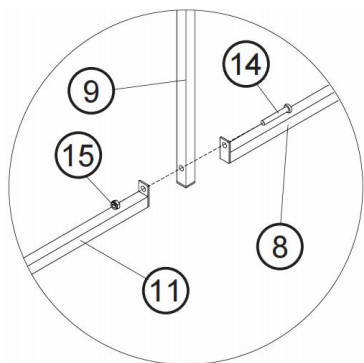
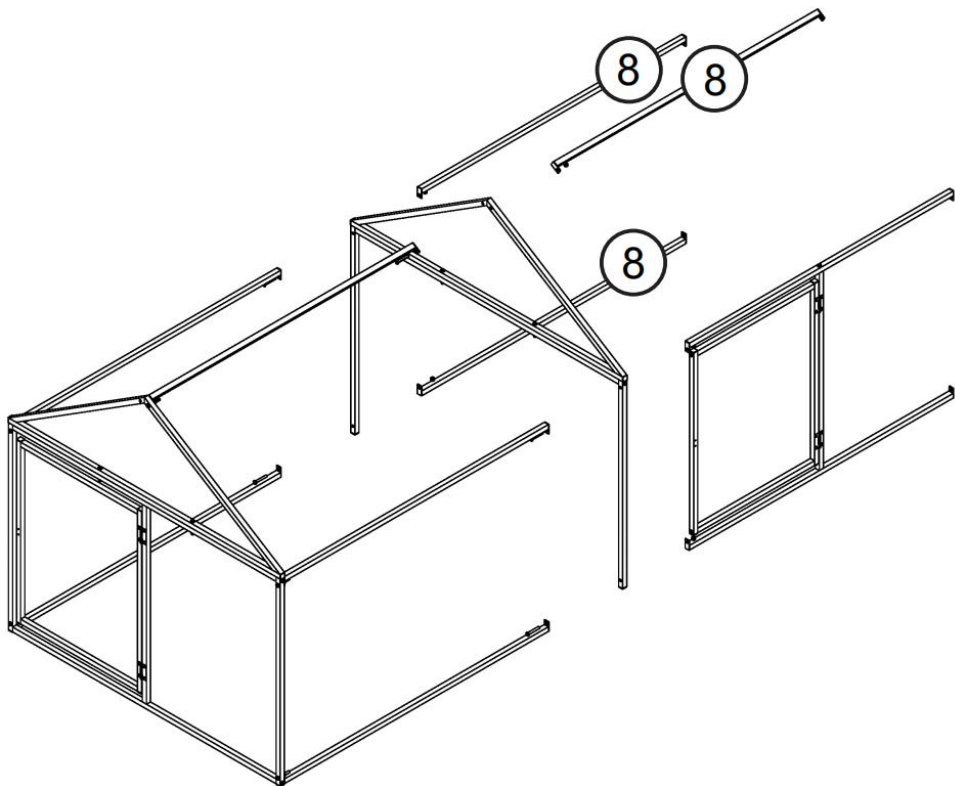

KROK 8						
	8	X3	14	X5	15	X5

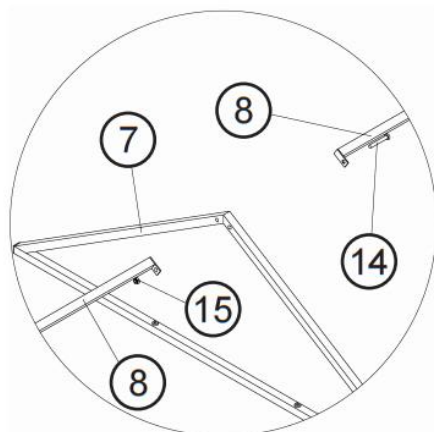
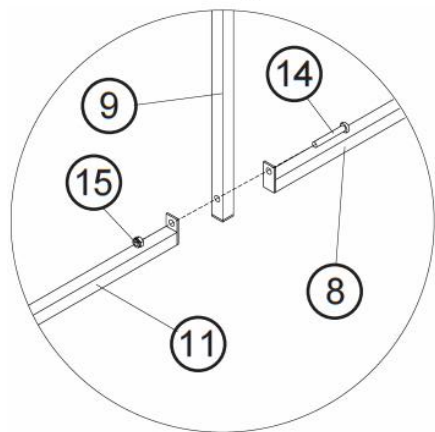
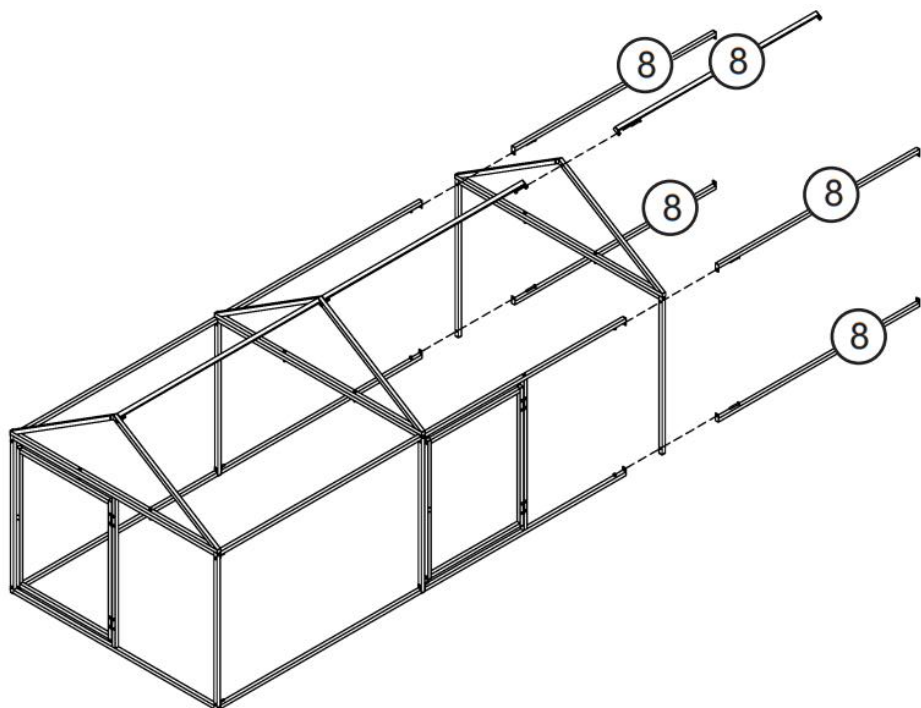

KROK 9						
	8	X5	14	X5	15	X5



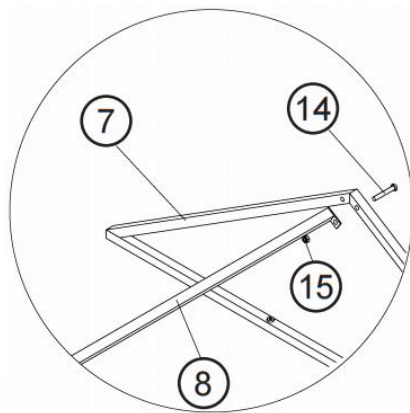
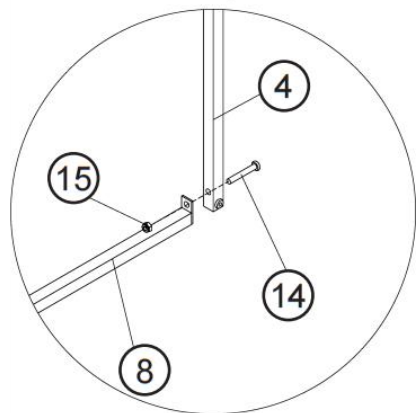
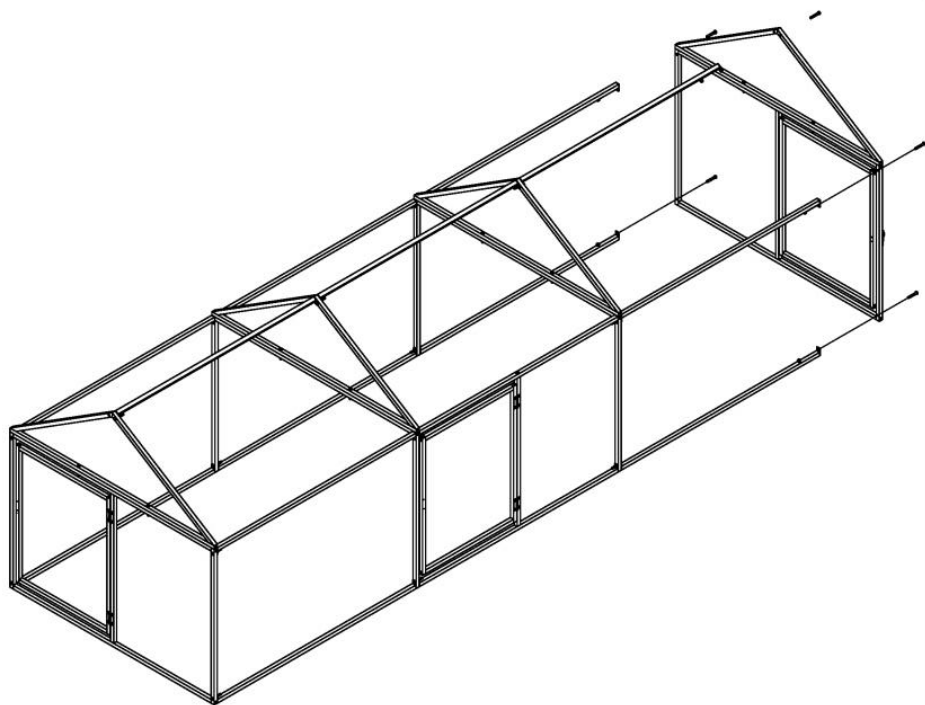

KROK 10				
	14	X5	15	X5

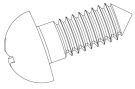

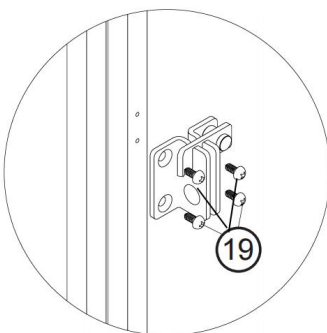
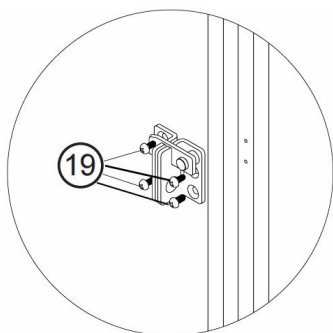
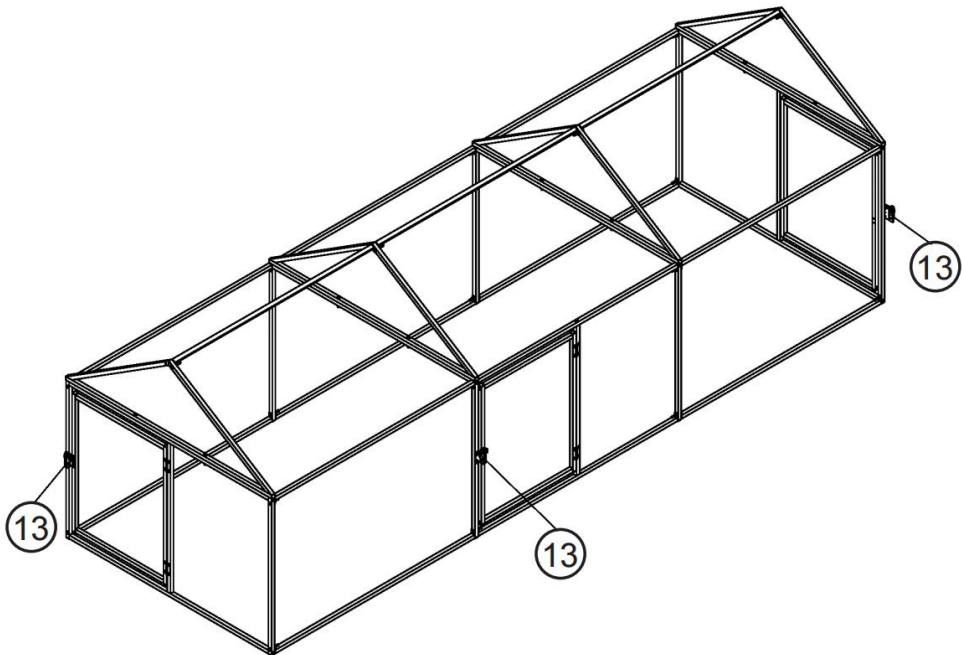
KROK 11				
	13	X3	19	X12



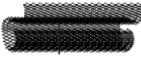

The holes for the left section needs to be drilled by yourself because the door maybe tilt after assembling due to gravity,so adjust the left section's position to make door close properly

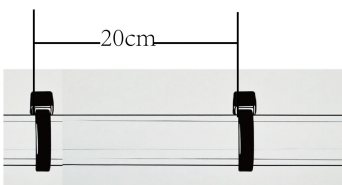
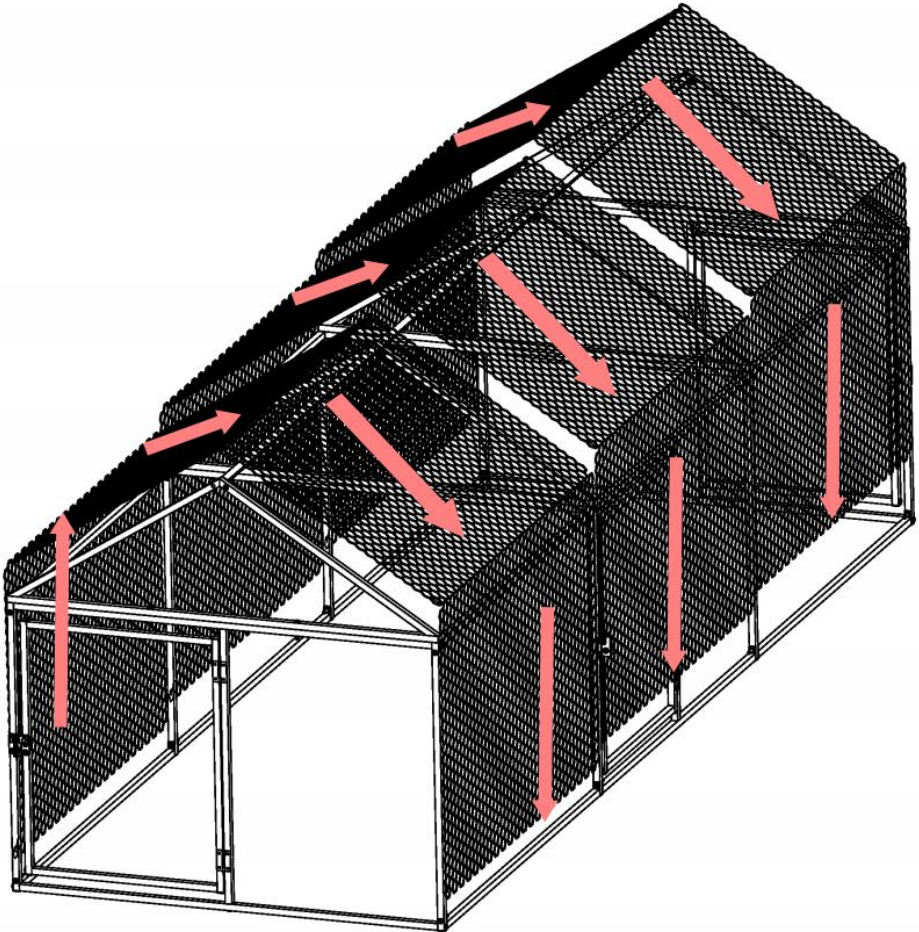
KROK 12				
	F	X1	N	X60



Use zip ties to tie the wire mesh and steel pipes together, with an interval of 20cm between each tie. Tighten the wire mesh by lowering the zip ties

KROK 13				
	F		N	X40

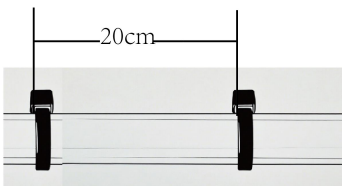
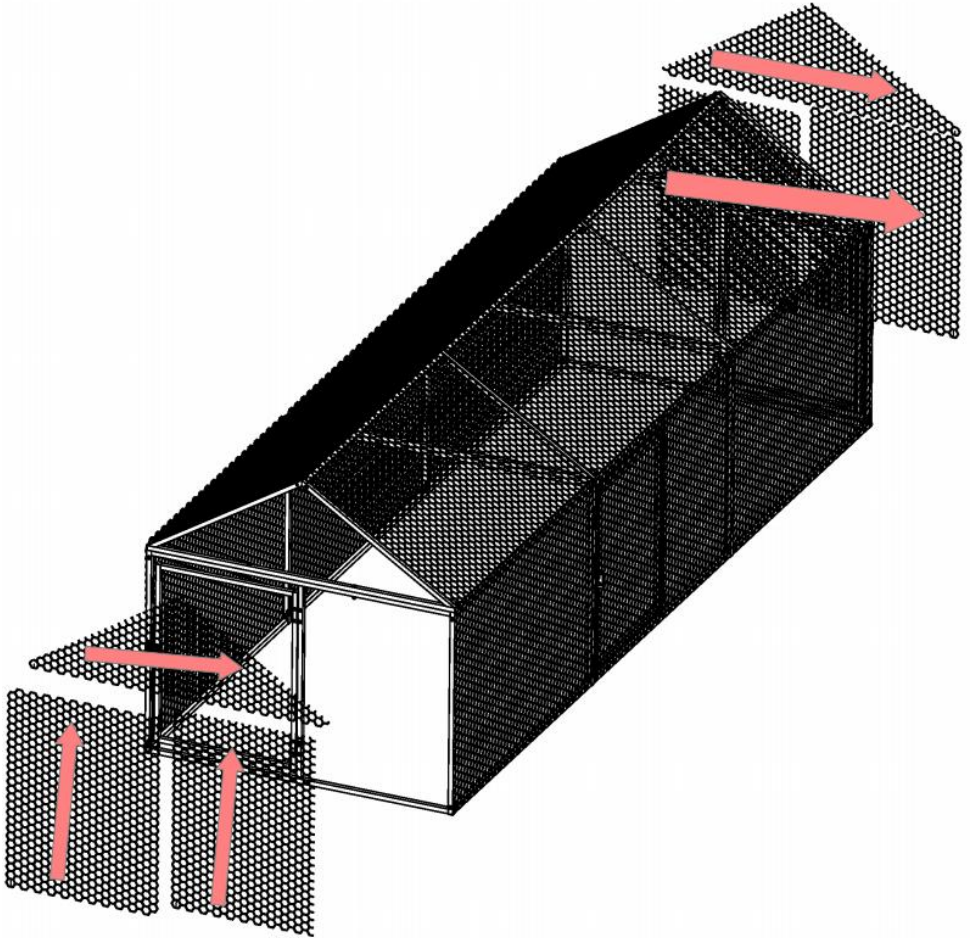

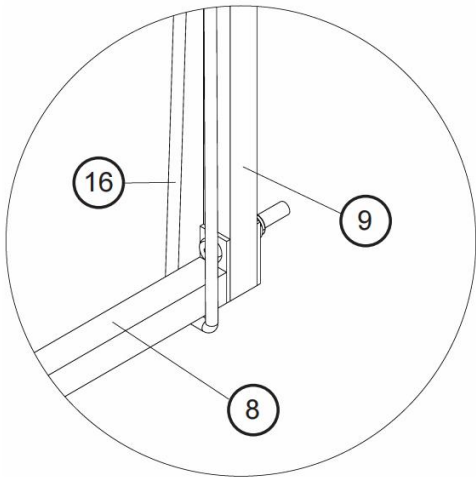
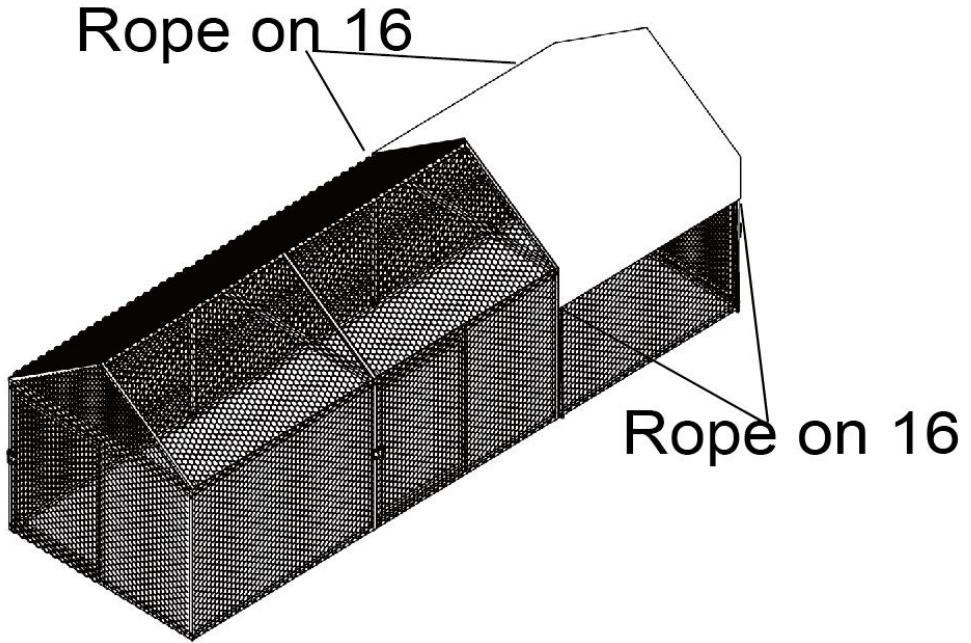

Use zip ties to tie the wire mesh and steel pipes together, with an interval of 20cm between each tie. Tighten the wire mesh by lowering the zip ties

KROK 14		
	16	X1

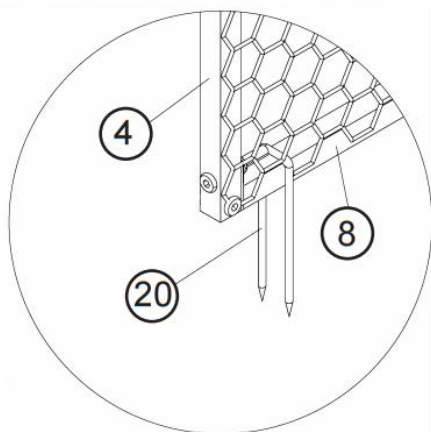
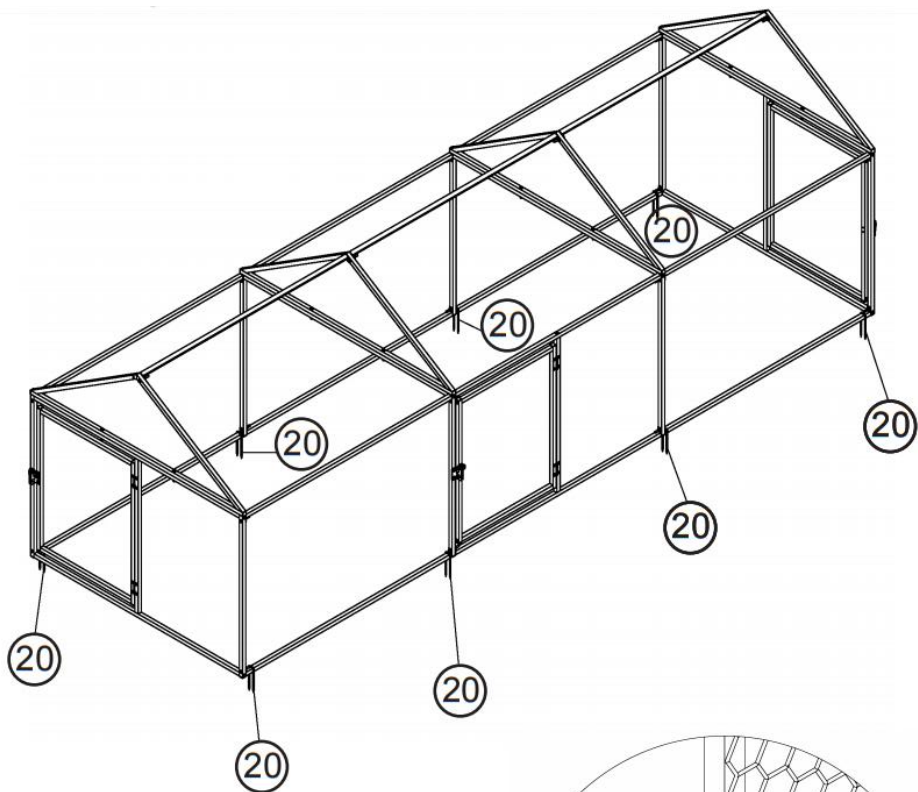

KROK 15		
	20	X8



KROK 16		
	Drut	X1

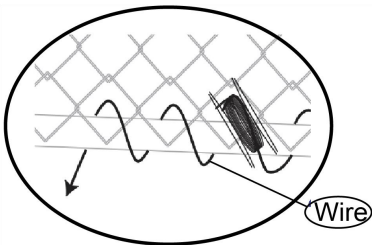
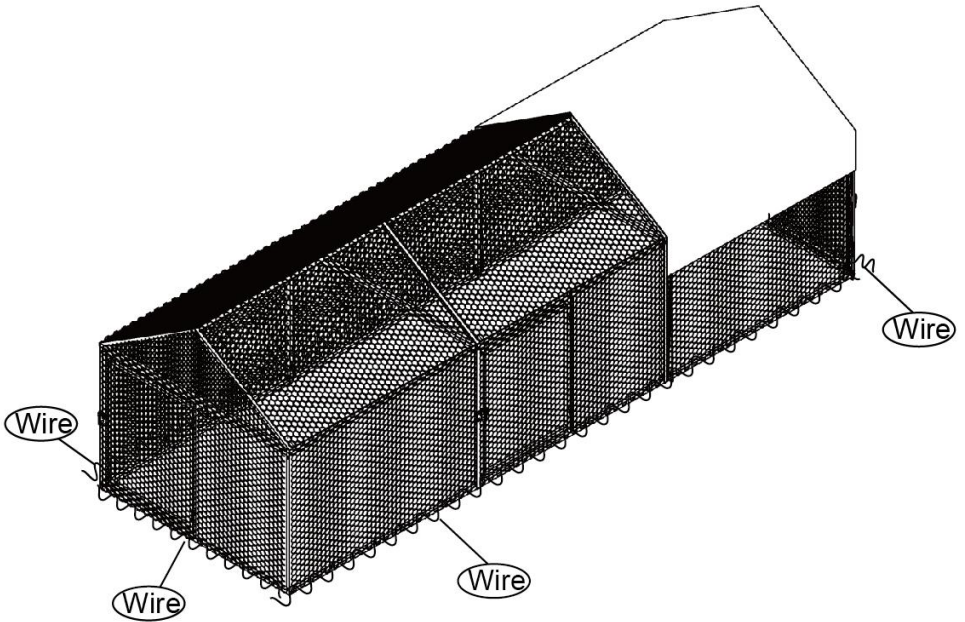

Note

Spiral wrap the wire at the bottom to reinforce the wire mesh and steel pipe, with a distance of 15cm between each circle. The single wire should not be wrapped more than 2 meters, and it needs to be tightened during wrapping. The knot should be firm and not loosened

PARAMETR PRODUKTU

Model	CRCFG0103
Kolor	B brak + biały
Rozmiar produktu	3 000×1000× 1 000 mm
Tworzywo	Tkanina Q235+PE

OGŁOSZENIE

Planowanie i wybór lokalizacji

Wybierz teren z wysokim terenem i dobrym drenażem, aby uniknąć rdzewienia elementów metalowych z powodu gromadzenia się wody w porze deszczowej. Wypoziomuj teren wcześniej, usuń kamienie, chwasty i inne zanieczyszczenia, a w razie potrzeby połóż fundamenty betonowe (szczególnie w przypadku dużych metalowych kurników), aby zwiększyć stabilność.

Kontrola materiałów i przygotowanie narzędzi

Sprawdź, czy blacha, rama, śruby i inne akcesoria są nienaruszone, czy nie występują odkształcenia, rdza lub uszkodzenia i przygotuj profesjonalne narzędzia, takie jak wiertarki elektryczne, klucze, miary taśmowe, narzędzia tnące (w razie potrzeby do dopasowania rozmiaru blachy) itp.

Kompleksowa inspekcja po instalacji

Sprawdź, czy cała konstrukcja jest stabilna, czy deski nie są luźne lub odkształcone, czy przełączniki drzwi i okien są gładkie oraz czy otwory wentylacyjne działają prawidłowo. Regularnie usuwaj odchody i zanieczyszczenia z kurnika, aby zapobiec gromadzeniu się brudu z korodujących elementów metalowych. Raz na kwartał sprawdzaj dokręcenie śrub i integralność powłok antykorozyjnych, sprawdzaj luzy

wiązań siatek i niezwłocznie rozwiązuj wszelkie wykryte problemy, aby wydłużyć żywotność kurnika.

Producent: Shanghaimuxinmuyeyouxiangongsi

Adres: Shuangchenglu 803nong11hao1602A-1609shi, baoshanqu, szanghaj 200000 CN.

Importowane do AUS: SIHAO PTY LTD. 1 ROKEVA

STREETEASTWOOD

NSW 2122 Australia

Importowane do USA: Sanven Technology Ltd. Suite 250, 9166 Anaheim

Miejsce, Rancho Cucamonga, CA 91730

UK	REP
-----------	------------

YH CONSULTING LIMITED. C/O YH Consulting
Limited Office 147, Centurion House, London
Road, Staines-upon-Thames, Surrey, TW18 4AX

EC	REP
-----------	------------

E-CrossStu GmbH
Mainzer Landstr.69,
60329 Frankfurt am Main.



VEVOR

Affordable. Reliable. Home Improvement.

METALEN KIPPENHOK

MODEL: CRCFG0103

VEVOR

Affordable. Reliable. Home Improvement.

METAL CHICKEN COOP

MODEL: CRCFG0103

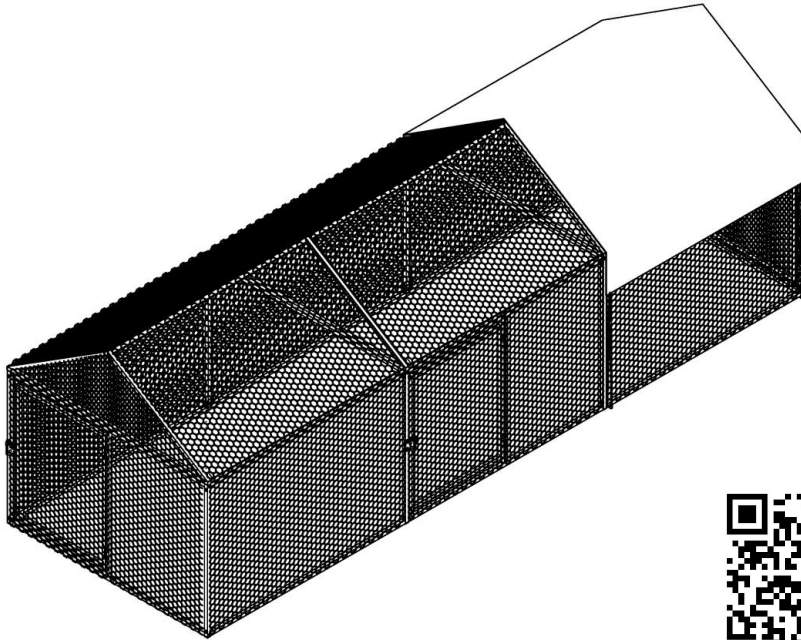

Video
installation QR

Dit is de originele handleiding. Lees alle instructies zorgvuldig door voordat u het product gebruikt. VEVOR behoudt zich het recht voor om de gebruiksaanwijzing duidelijk te interpreteren. Het uiterlijk van het product is afhankelijk van het product dat u hebt ontvangen. Neemt u het ons niet kwalijk dat we u niet meer op de hoogte stellen van eventuele technologische of software-updates voor ons product.

SAFETY INSTRUCTIONS

WAARSCHUWING:

Lees dit materiaal voordat u dit product gebruikt. Het niet naleven hiervan kan ernstig letsel tot gevolg hebben.

Vorzorgsmaatregelen voor montage

1. Monteer uitsluitend volgens deze instructies. Onjuiste montage kan gevaarlijk zijn.
2. Draag tijdens de montage een ANSI-goedgekeurde veiligheidsbril en stevige werkhandschoenen.
3. Houd de verzamelplaats schoon en goed verlicht.
4. Houd omstanders tijdens de montage uit de buurt.
5. Kom niet in actie als u moe bent of onder invloed van alcohol, drugs of medicijnen.
6. De producteigenschappen gelden uitsluitend voor correct en volledig gemonteerde producten.
7. Raadpleeg voor meer informatie over de onderdelen die op de volgende pagina's worden vermeld het montageschema in deze handleiding. Pak alle onderdelen uit en scheid ze van elkaar op een schone werkplek.
8. Er zijn veel productcomponenten. Het is aan te raden de installatie door twee personen uit te voeren, wat de installatietijd kan verkorten.

Gebruik voorzorgsmaatregelen





















1. NIET OP DIT ITEM ZITTEN OF STAAN.
2. Dit product is geen speelgoed. Laat kinderen niet met of in de buurt van dit artikel spelen.
3. Niet overschrijden aangegeven gewichtscapaciteiten.
4. Alleen gebruiken zoals bedoeld.
5. Controleer het product voor elk gebruik. Niet gebruiken als er onderdelen loszitten of beschadigd zijn.

BEWAAR DEZE HANDLEIDING

TOOLS





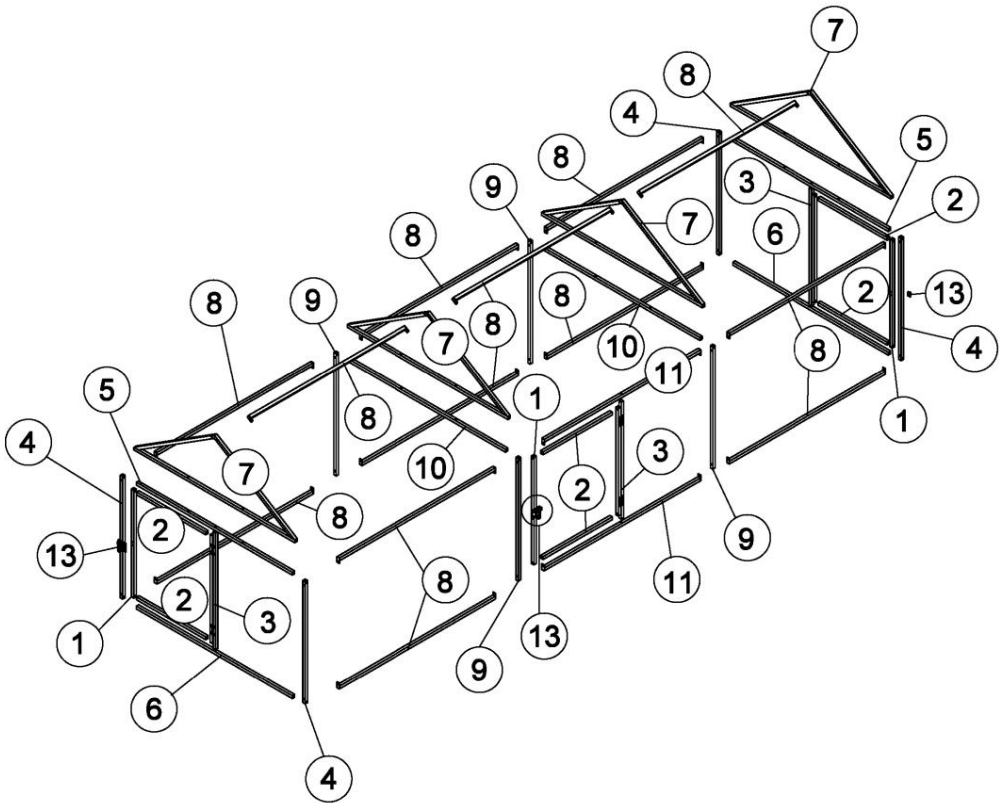

PARTS LIST

Item no.	Reference Image	Qty.	Item no.	Reference Image	Qty.
1		x3	2		x6
3		x3	4		x4
5		x2	6		x2
7		x4	8		x13
9		x4	10		x2
11		x2	13		x3
14		x58	15		x28
16		x1	17		x28
18	 1*12M	x1	19		x12
wire		x1	20		x8
21		x100			

EXPLODED VIEW



ASSEMBLY

STAP 1										
	1	X3	2	X6	3	X3	17	X12	14	X12





x3

Before

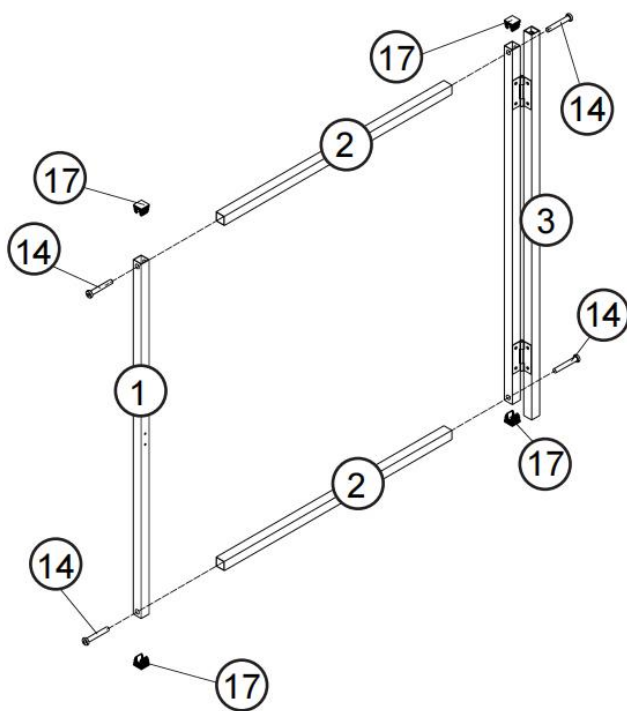



After



STAP 2										
	4	X4	5	X2	6	X2	17	X4	14	X12

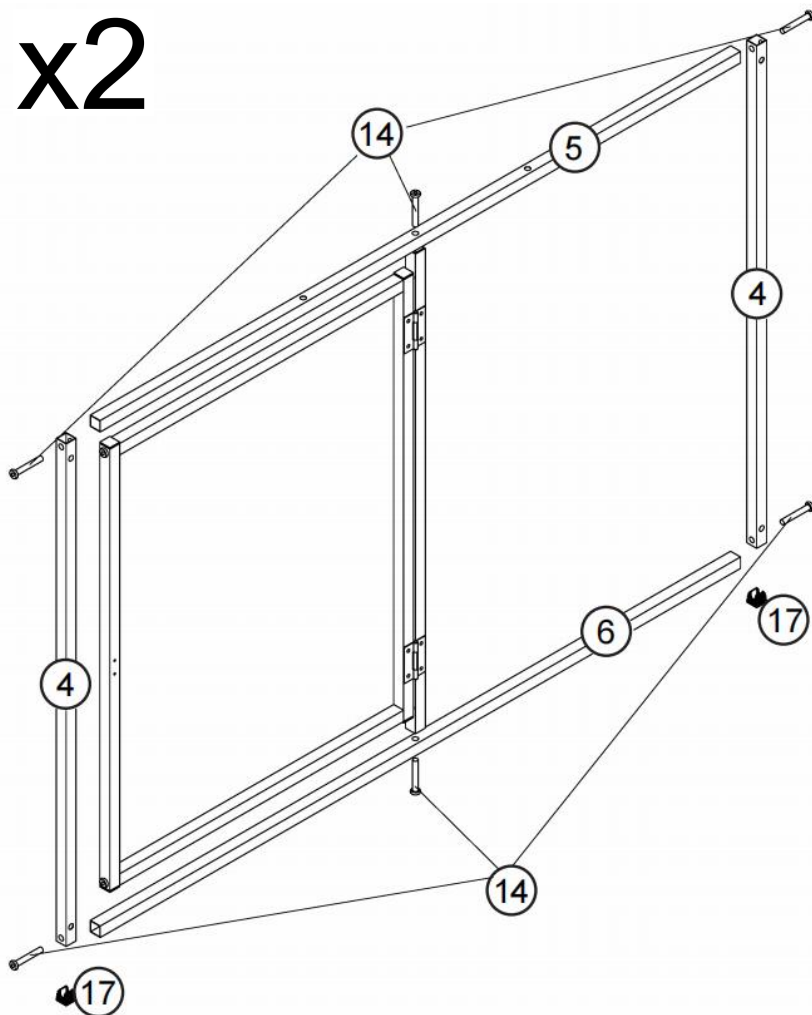

x2



STAP 3				
	7	X4	17	X8

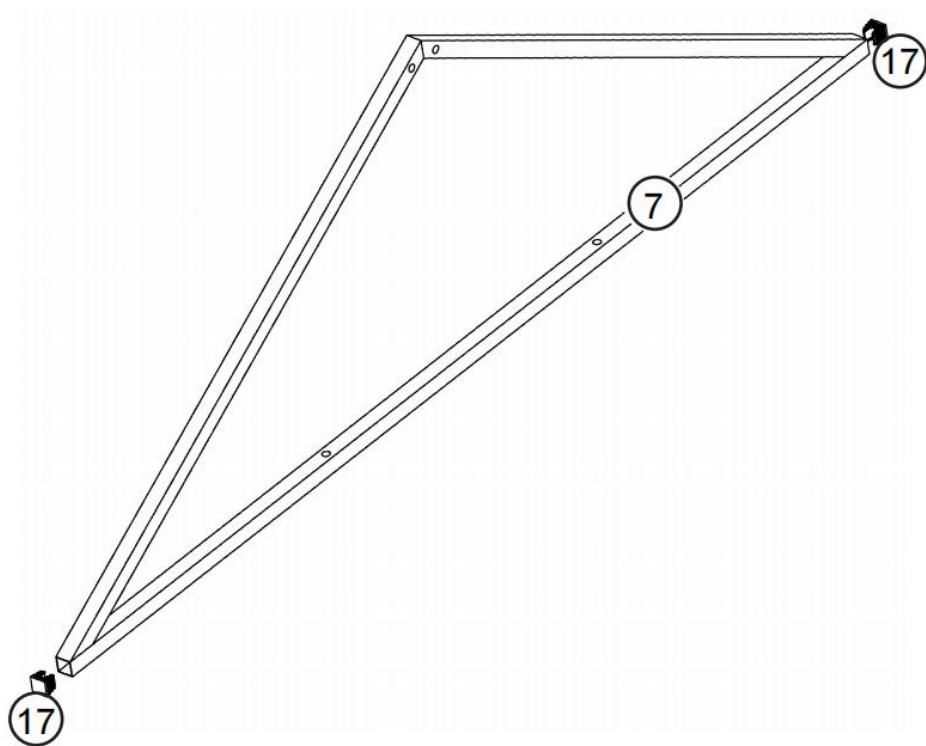

x4





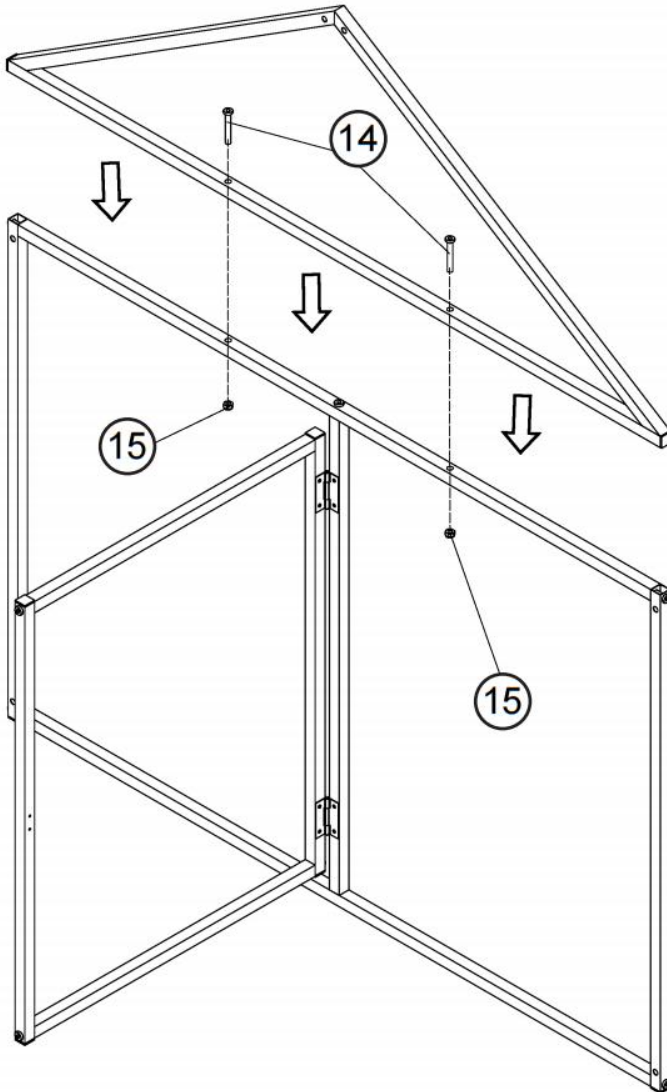

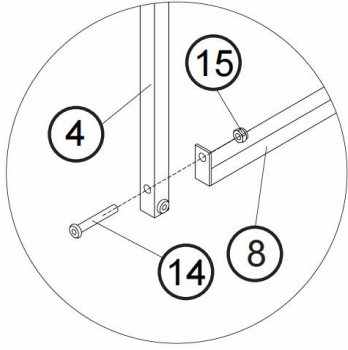
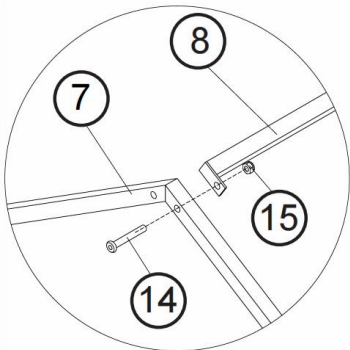
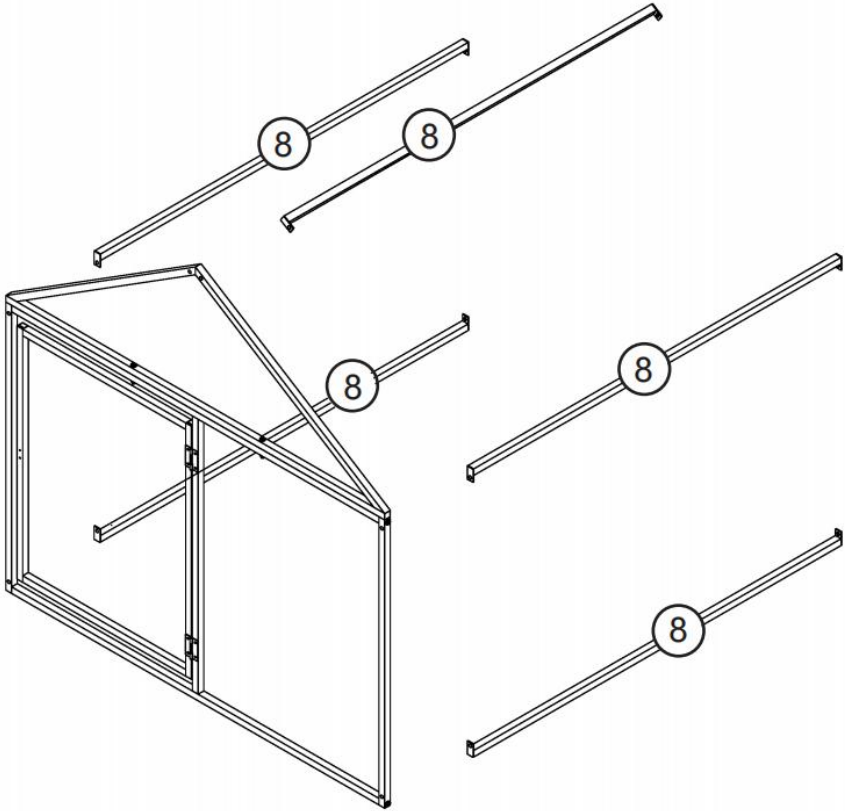

STAP 4				
	14	X4	15	X4

x2





STAP 5						
	8	X5	14	X5	15	X5





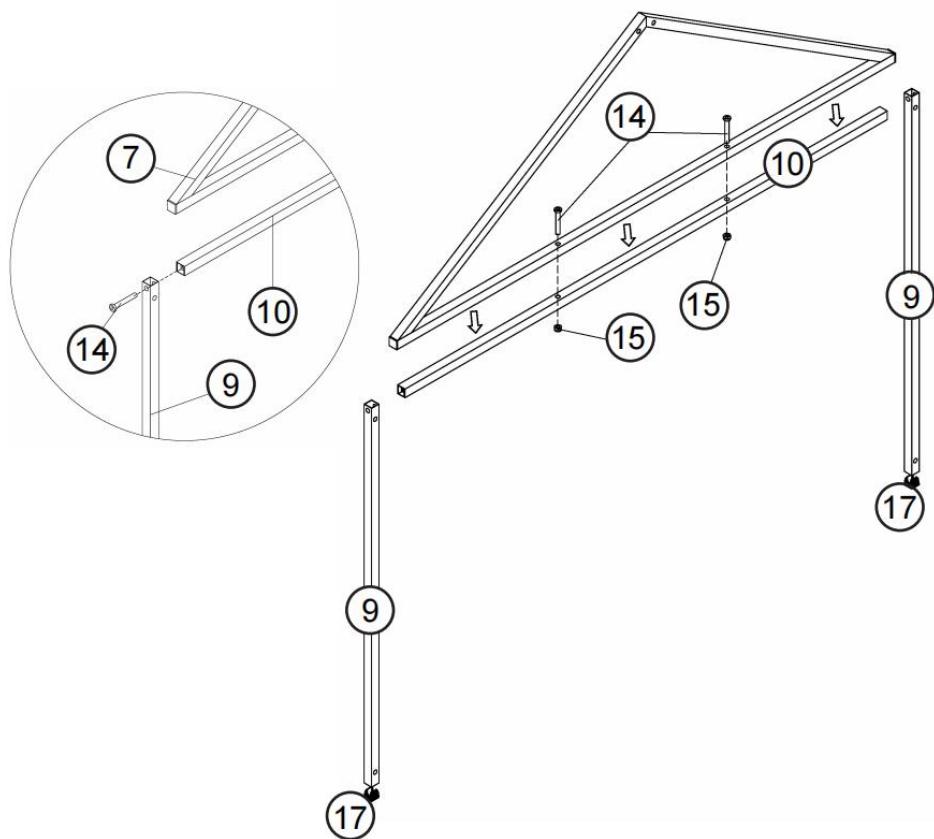

STAP 6										
	9	X4	10	X2	14	X8	15	X4	14	X4

x2

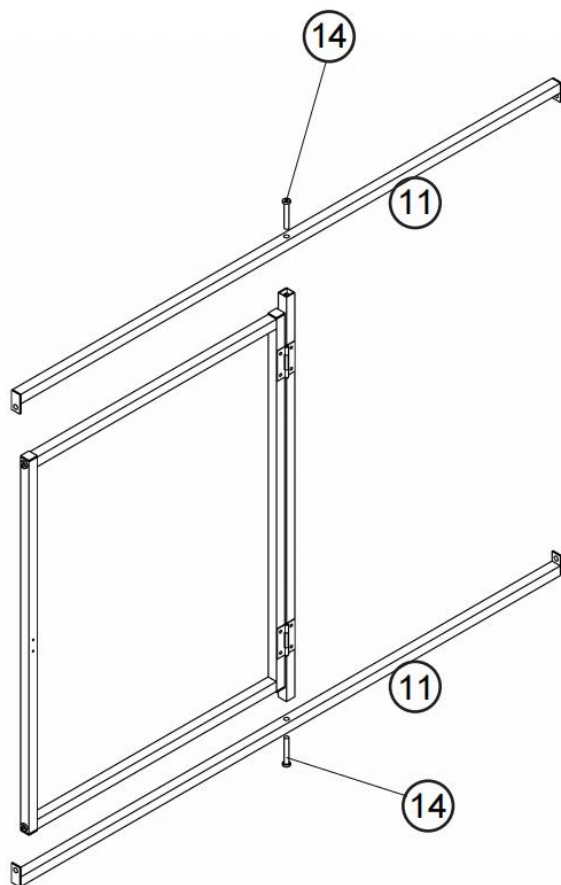
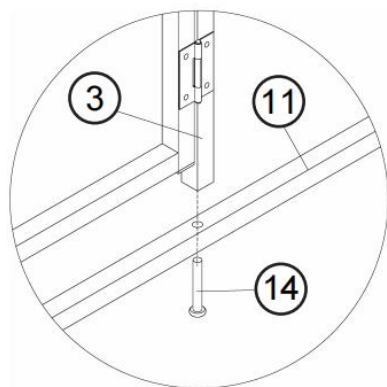



STAP 7				
	11	X2	14	X2



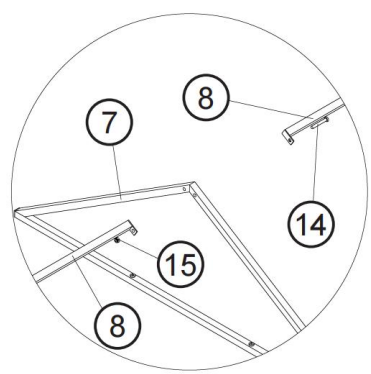
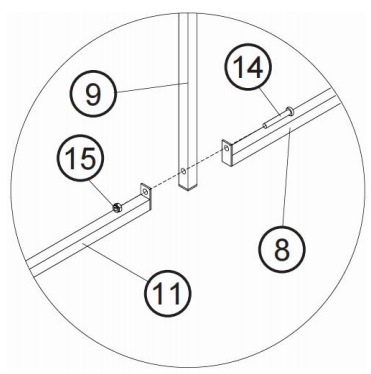
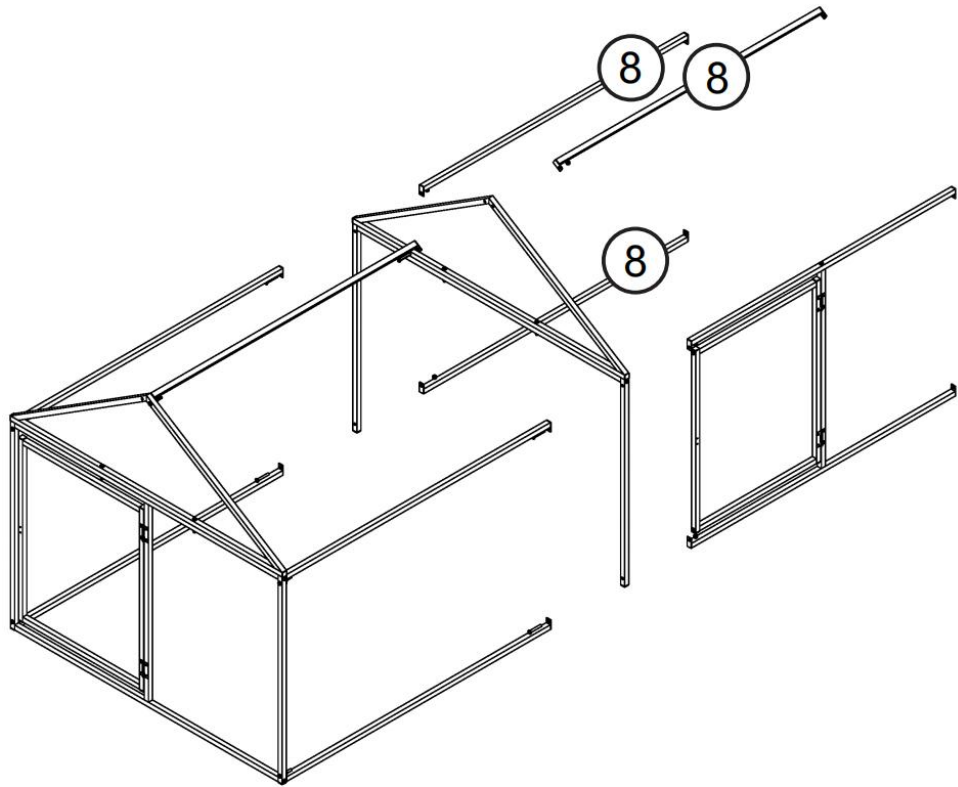

STAP 8						
	8	X3	14	X5	15	X5

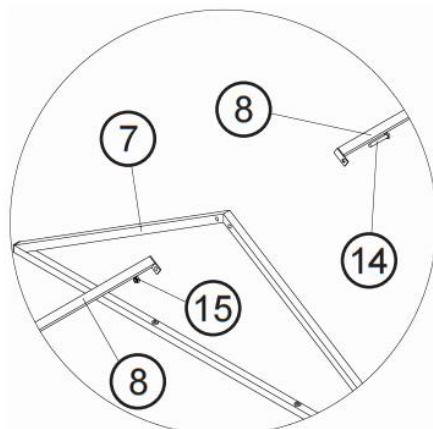
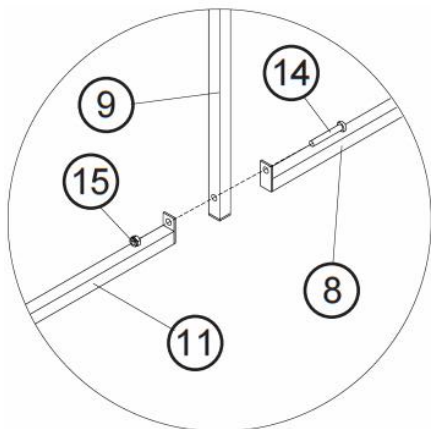
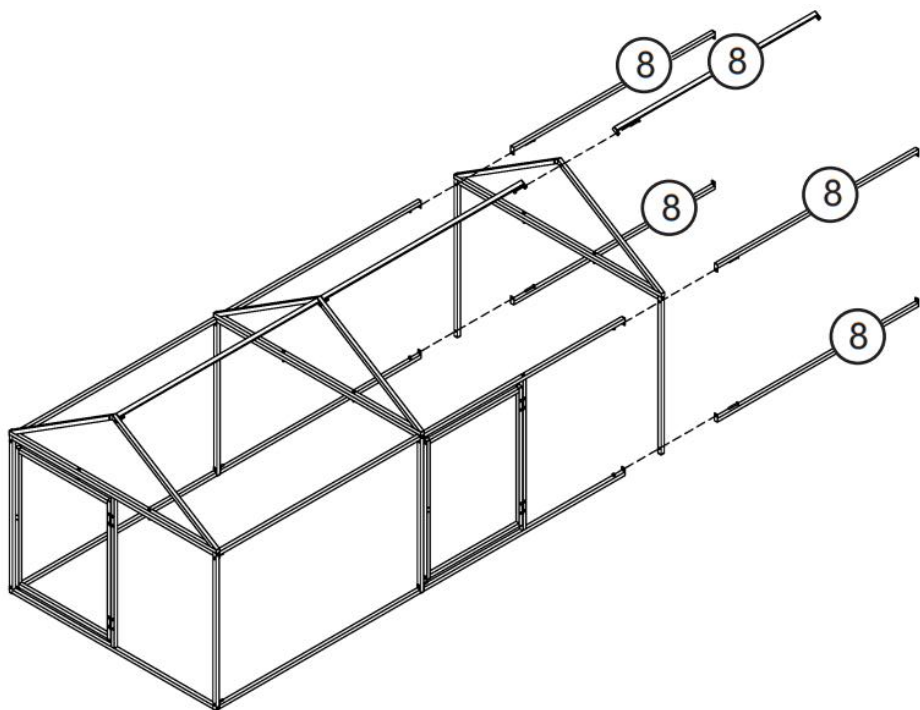

STAP 9						
	8	X5	14	X5	15	X5



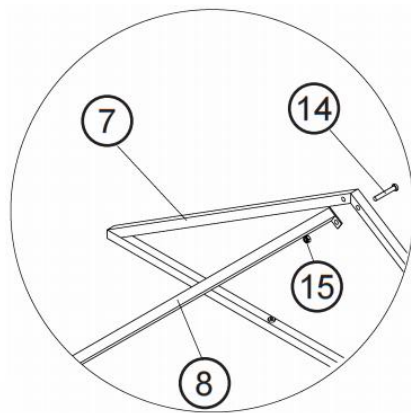
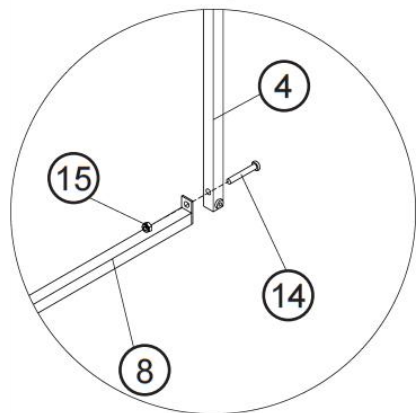
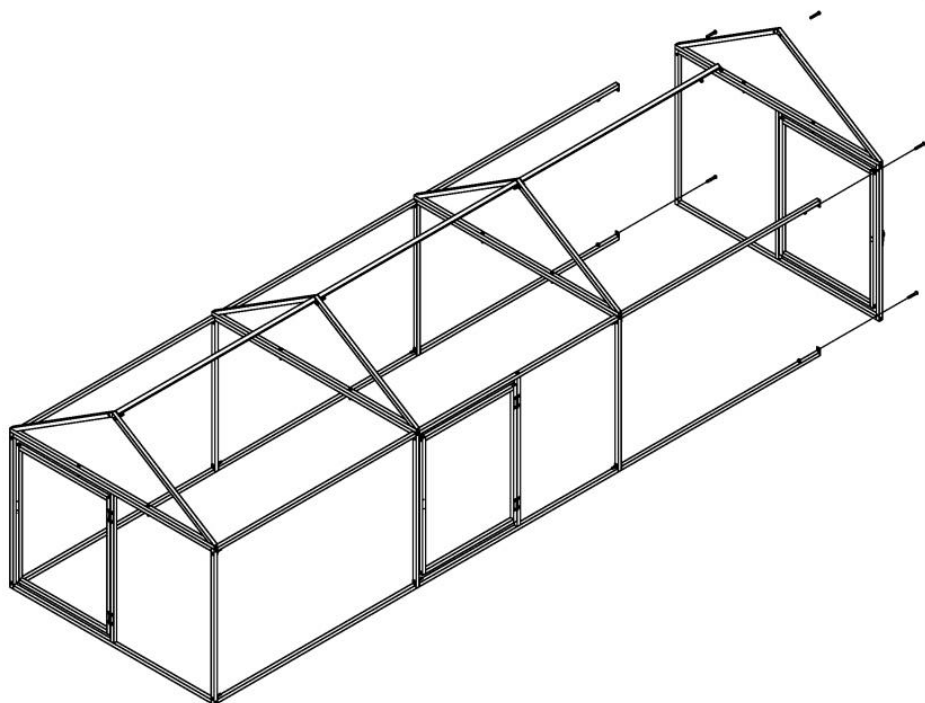

STAP 10				
	14	X5	15	X5

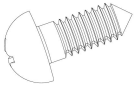

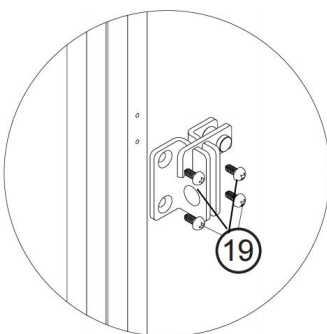
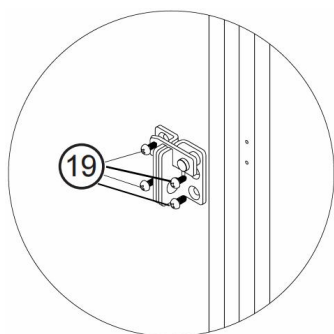
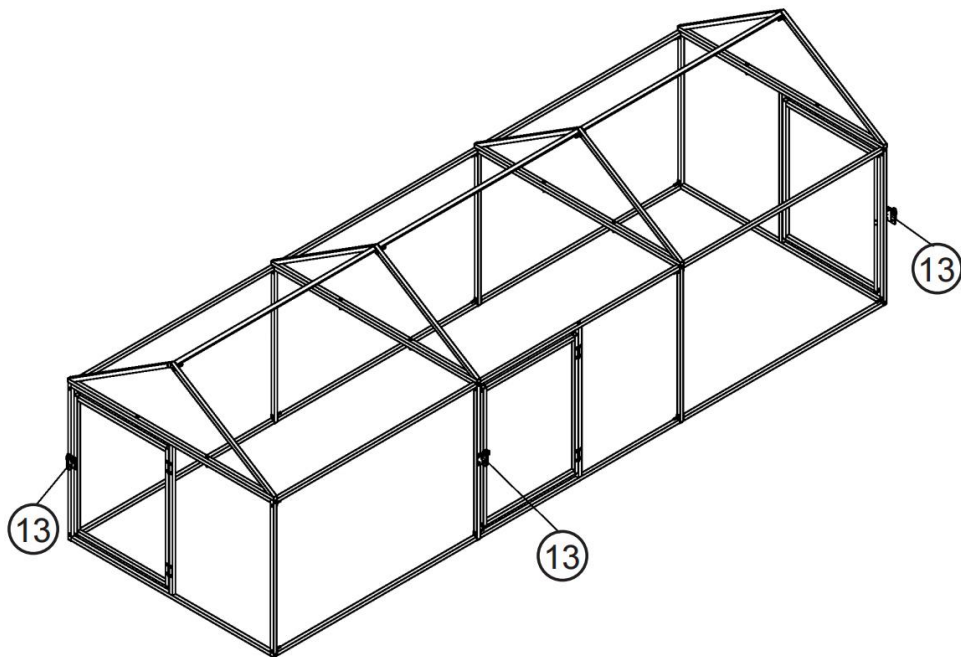
STAP 11				
	13	X3	19	X12



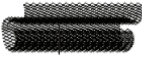

The holes for the left section needs to be drilled by yourself because the door maybe tilt after assembling due to gravity,so adjust the left section's position to make door close properly

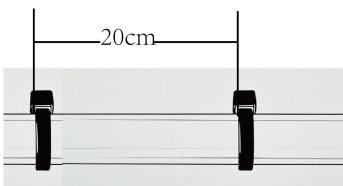
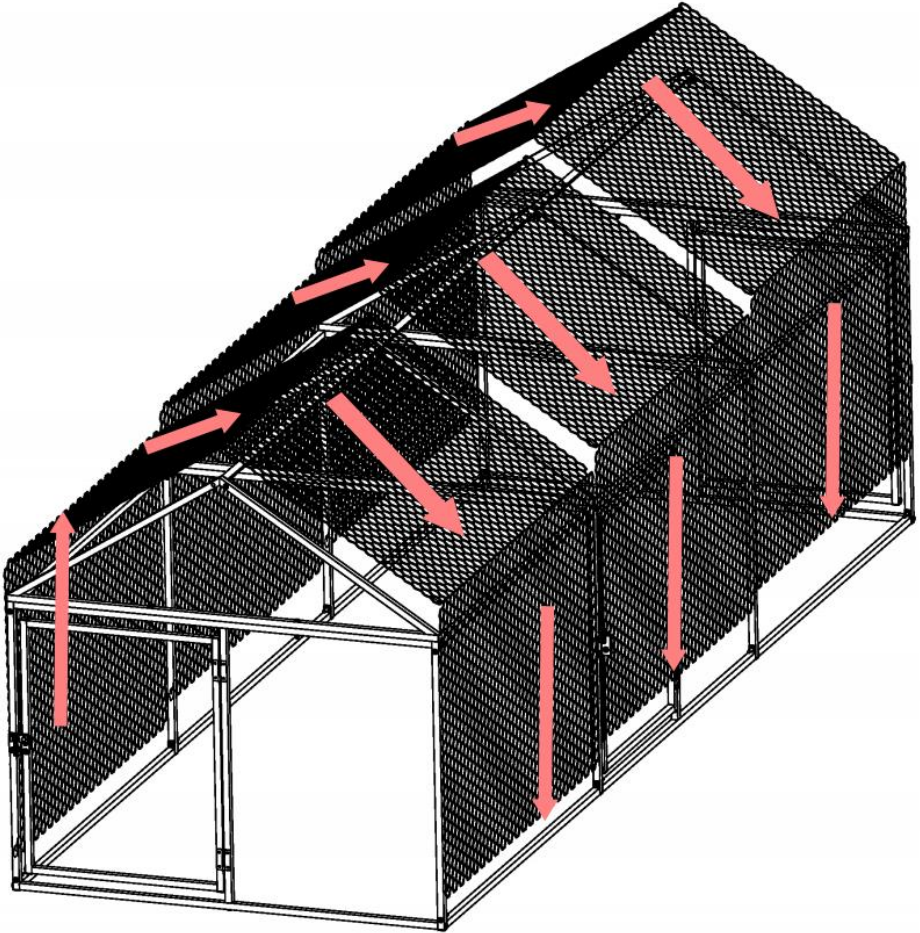
STAP 12				
	F	X1	N	X60



Use zip ties to tie the wire mesh and steel pipes together, with an interval of 20cm between each tie. Tighten the wire mesh by lowering the zip ties

STAP 13				
	F		N	X40

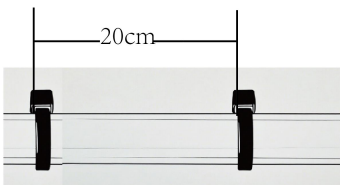
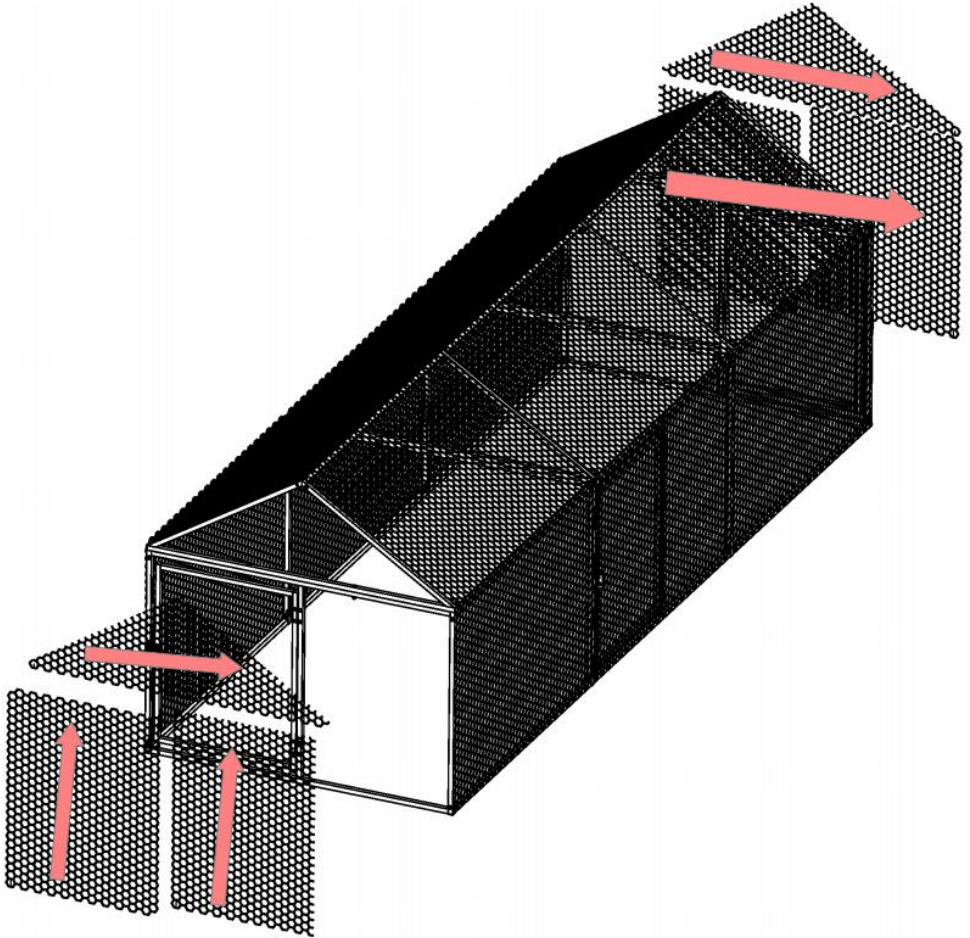

Use zip ties to tie the wire mesh and steel pipes together, with an interval of 20cm between each tie. Tighten the wire mesh by lowering the zip ties

STAP 14		
	16	X1

Rope on 16

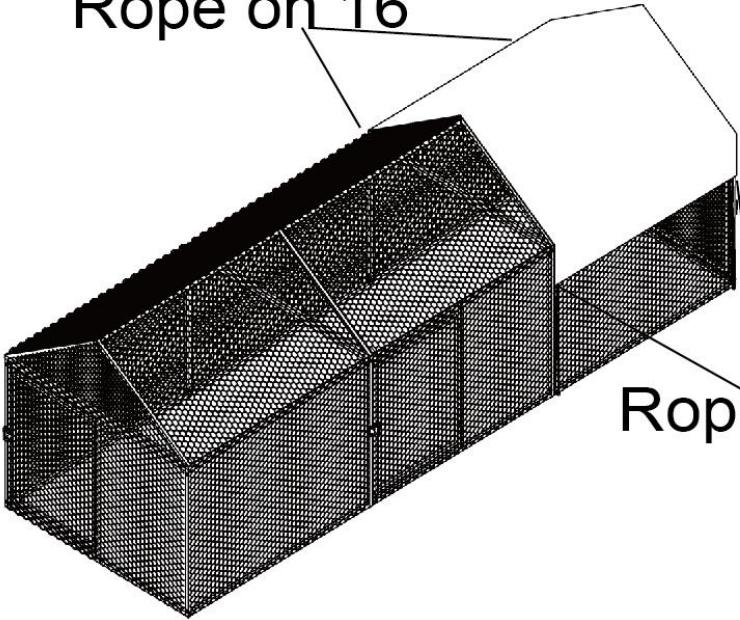

Rope on 16

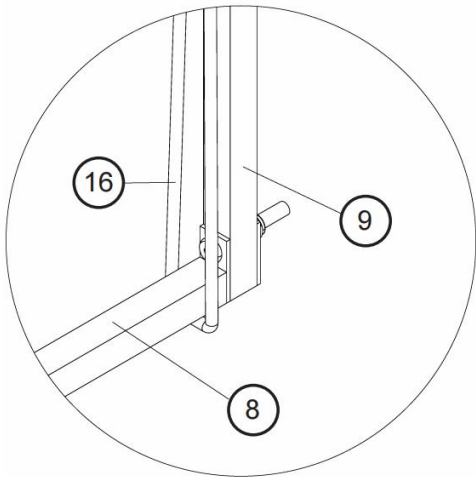

STAP 15		
	20	X8

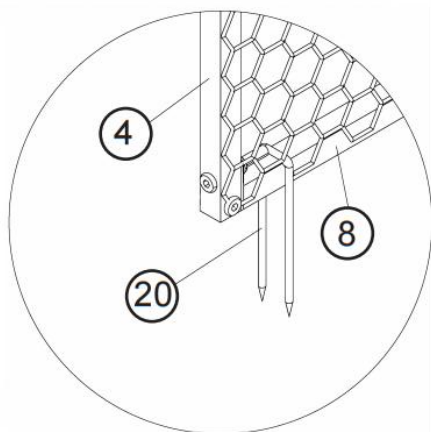
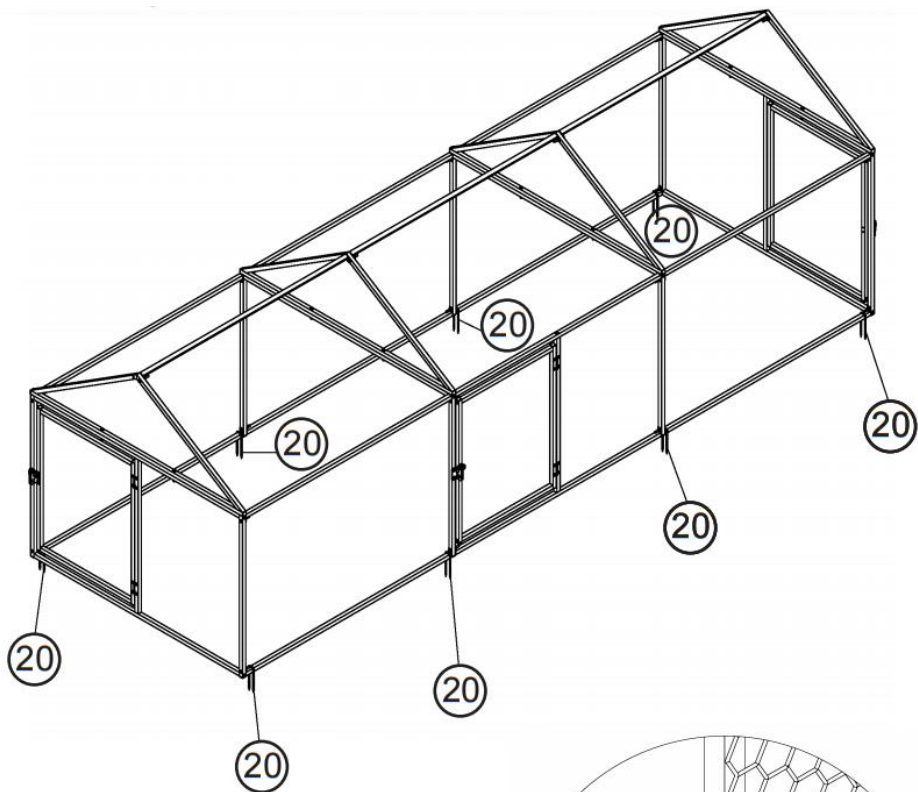

STAP 16		
	Draad d	X1

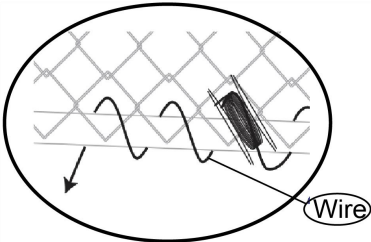
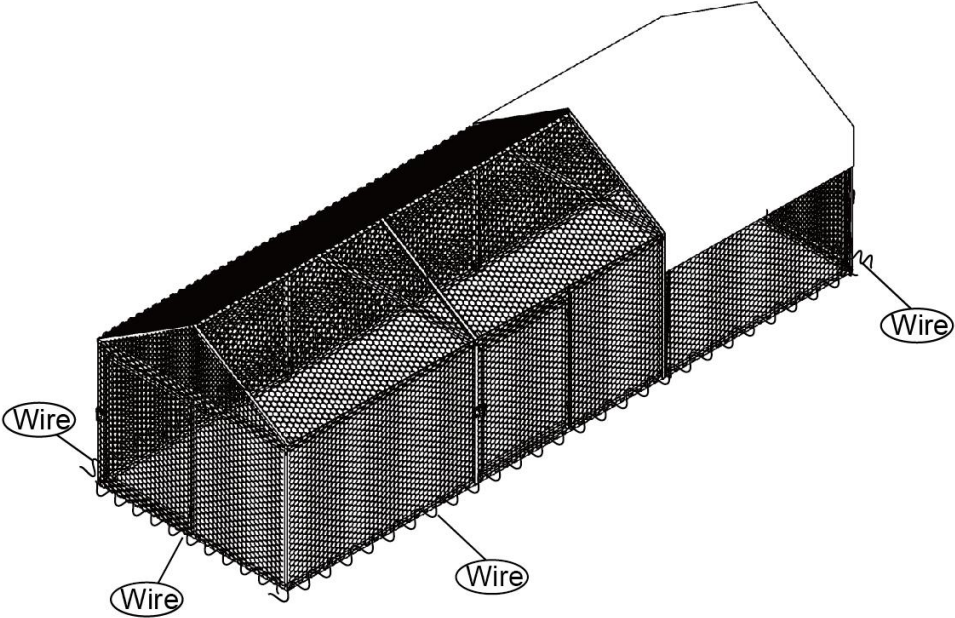

Note

Spiral wrap the wire at the bottom to reinforce the wire mesh and steel pipe, with a distance of 15cm between each circle. The single wire should not be wrapped more than 2 meters, and it needs to be tightened during wrapping. The knot should be firm and not loosened

PRODUCTPARAMETER

Model	CRCFG0103
Kleur	Zwart + Wit
Productgrootte	3 000×1000× 1 000mm
Materiaal	Q235+PE-doek

KENNISGEVING

Locatieplanning en -selectie

Kies gebieden met een hoog terrein en goede drainage om te voorkomen dat metalen onderdelen roesten door waterophoping tijdens het regenseizoen. Egaliseer de locatie van tevoren, verwijder stenen, onkruid en ander afval en leg indien nodig een fundering van beton (met name bij grote metalen kippenhokken) om de stabiliteit te verbeteren.

Materiaalinspectie en gereedschapsvoorbereiding

Controleer of de metalen plaat, het frame, de schroeven en andere accessoires intact zijn en of er geen vervorming, roest of beschadigingen zijn. Zorg dat u professioneel gereedschap bij de hand hebt, zoals elektrische boormachines, sleutels, rolmaten, snijgereedschap (indien nodig om de maat van de plaat aan te passen), enz.

Uitgebreide inspectie na installatie

Controleer of de algehele constructie stabiel is, of de planken los of vervormd zitten, of de deur- en raamschakelaars soepel lopen en of de ventilatieopeningen goed werken. Maak het kippenhok regelmatig schoon van uitwerpselen en vuil om te voorkomen dat er zich vuil ophoopt door corroderende metalen onderdelen. Controleer elk kwartaal de aandrijving van schroeven en de integriteit van antiroestcoatings, inspecteer de netbinding op losheid en los eventuele problemen direct op om de levensduur van het kippenhok te verlengen.

Fabrikant: Shanghaimuxinmuyeyouxiangongsi

Adres: Shuangchenglu 803nong11hao1602A-1609shi, baoshanqu, shanghai 200000 CN.

Geïmporteerd naar AUS: SIHAO PTY LTD. 1 ROKEVA
STREETEASTWOOD

NSW 2122 Australië

Geïmporteerd naar de VS: Sanven Technology Ltd. Suite 250, 9166
Anaheim

Plaats, Rancho Cucamonga, CA 91730

UK	REP
-----------	------------

YH CONSULTING LIMITED. C/O YH Consulting
Limited Office 147, Centurion House, London
Road, Staines-upon-Thames, Surrey, TW18 4AX

EC	REP
-----------	------------

E-CrossStu GmbH
Mainzer Landstr.69,
60329 Frankfurt am Main.



VEVOR

Affordable. Reliable. Home Improvement.

HÖNSHUS I METALL

MODELL: CRCFG0103

VEVOR

Affordable. Reliable. Home Improvement.

METAL CHICKEN COOP

MODELL: CRCFG0103

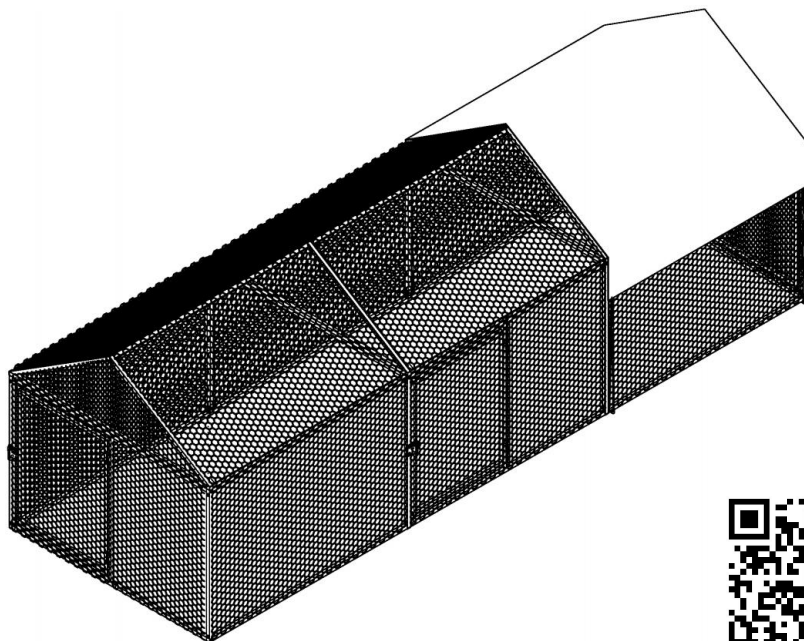

Video
installation QR

Detta är originalinstruktionerna, vänligen läs alla instruktioner noggrant innan du använder produkten. VEVOR förbehåller sig en tydlig tolkning av vår användarmanual. Produktens utseende ska vara beroende av den produkt du mottagit. Vi ber om ursäkt för att vi inte kommer att informera dig igen om det finns några teknik- eller programuppdateringar för vår produkt.

SAFETY INSTRUCTIONS

WARNING:

Läs detta material innan du använder produkten. Underlåtenhet att göra det kan leda till allvarliga skador.

Monteringsförsiktighetsåtgärder

1. Montera endast enligt dessa instruktioner. Felaktig montering kan skapa risker.
2. Använd ANSI-godkända skyddsglasögon och kraftiga arbetshandskar under monteringen.
3. Håll samlingsområdet rent och väl upplyst.
4. Håll åskådare borta från området under monteringen.
5. Montera inte om du är trött eller påverkad av alkohol, droger eller mediciner.
6. Produktegenskaperna gäller endast korrekt och fullständigt monterade produkter.
7. För ytterligare information om delarna som listas på följande sidor, se monterings schemat i denna manual. Packa upp och separera alla delar på en ren arbetsyta.
8. Produkten har många komponenter. Det rekommenderas att två personer utför installationen, vilket kan förkorta installationstiden.

Använd försiktighetsåtgärder

1. SITTA ELLER STÅ INTE PÅ DENNA FÖRENING.
2. Denna produkt är inte en leksak. Låt inte barn leka med eller i närheten av denna produkt.
3. Överskrid inte angivna viktkapacitet.
4. Använd endast som avsett.
5. Kontrollera före varje användning; använd inte om delar är lösa eller skadade.

SPARA DENNA HANDBOK

TOOLS





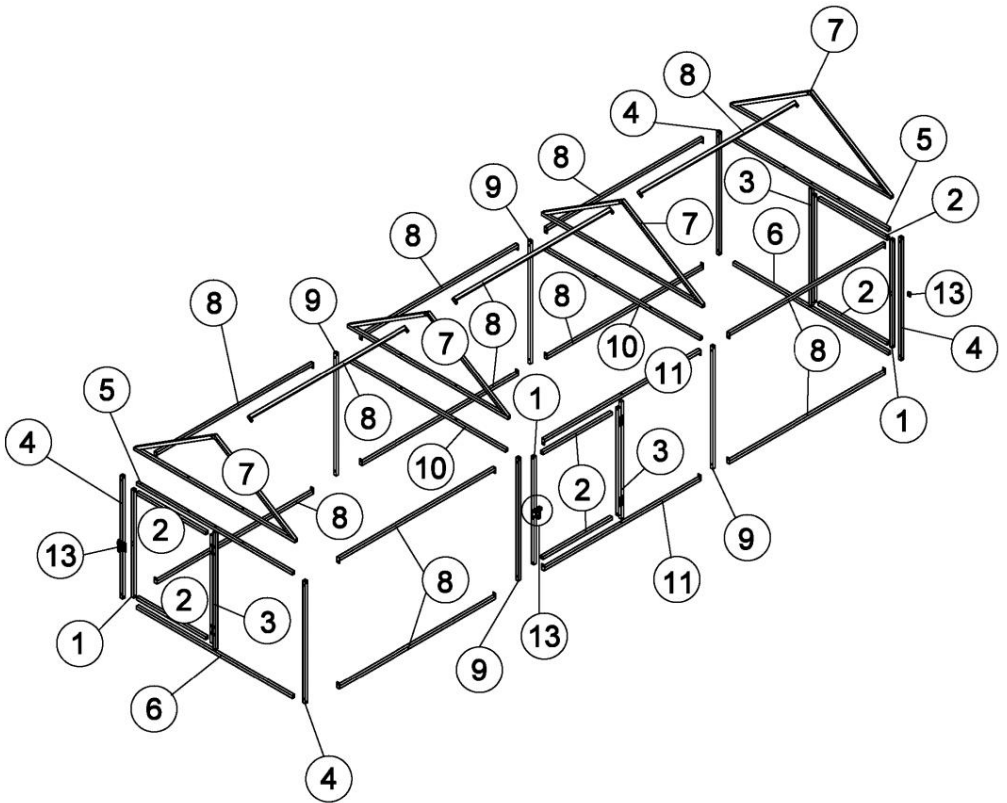

PARTS LIST

Item no.	Reference Image	Qty.	Item no.	Reference Image	Qty.
1		x3	2		x6
3		x3	4		x4
5		x2	6		x2
7		x4	8		x13
9		x4	10		x2
11		x2	13		x3
14		x58	15		x28
16		x1	17		x28
18	 1*12M	x1	19		x12
wire		x1	20		x8
21		x100			

EXPLODED VIEW



ASSEMBLY

STEP1										
	1	X3	2	X6	3	X3	17	X12	14	X12





x3

Before

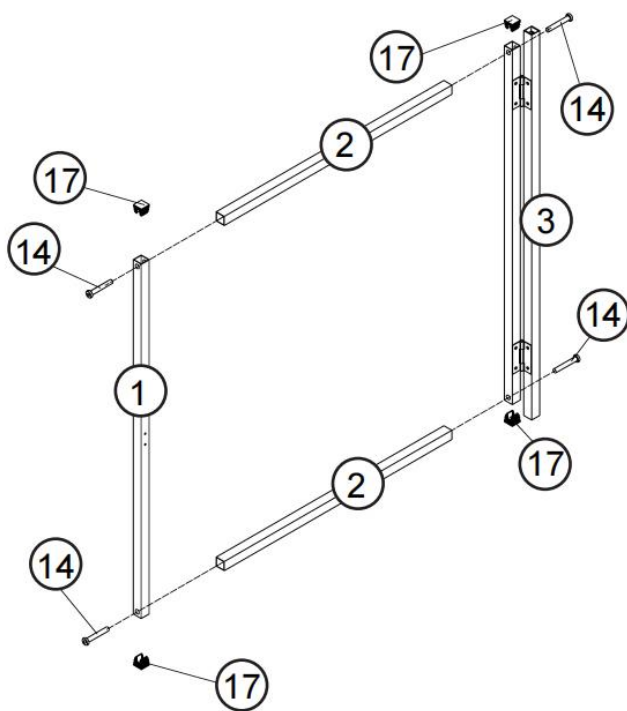



After



STEG2										
	4	X4	5	X2	6	X2	17	X4	14	X12

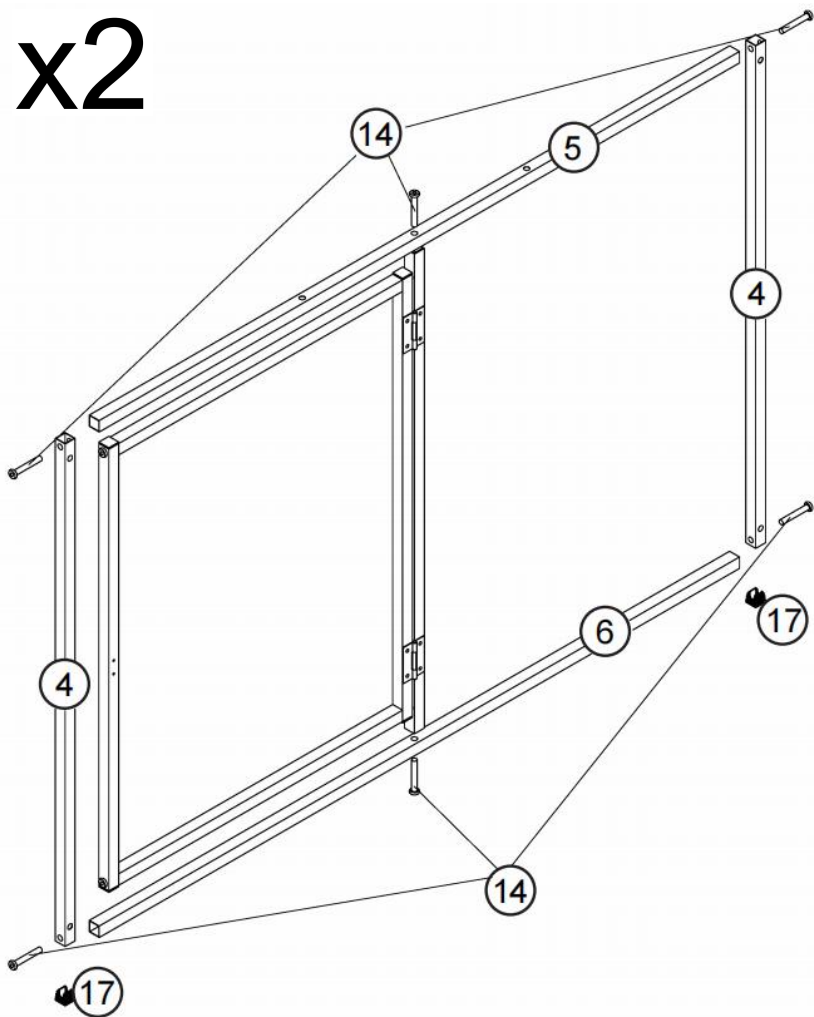

x2



STEP3				
	7	X4	17	X8

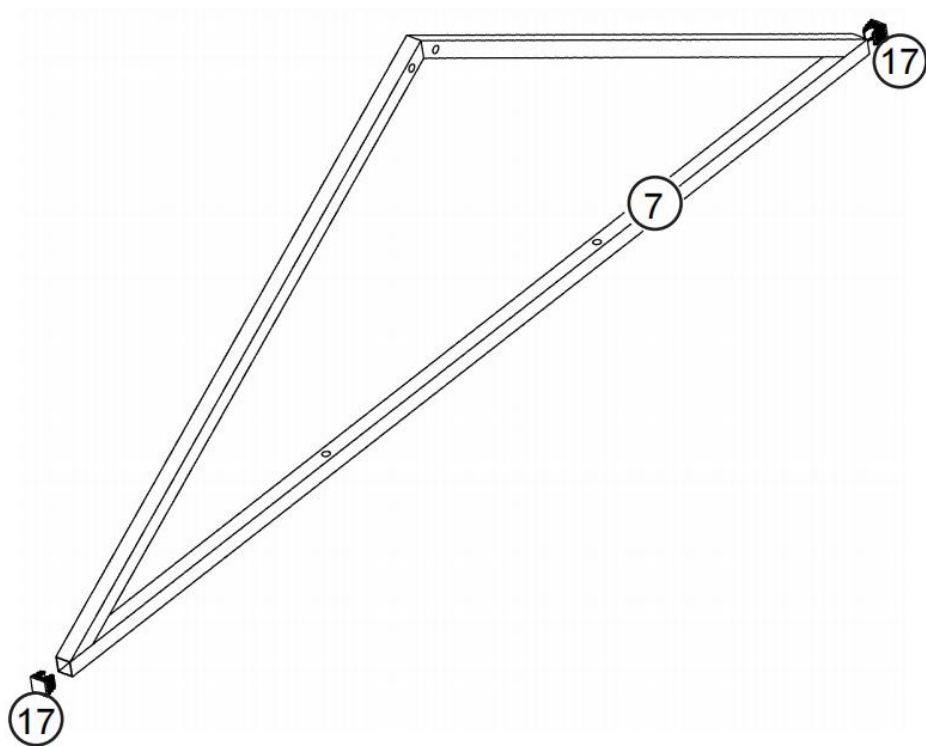

x4





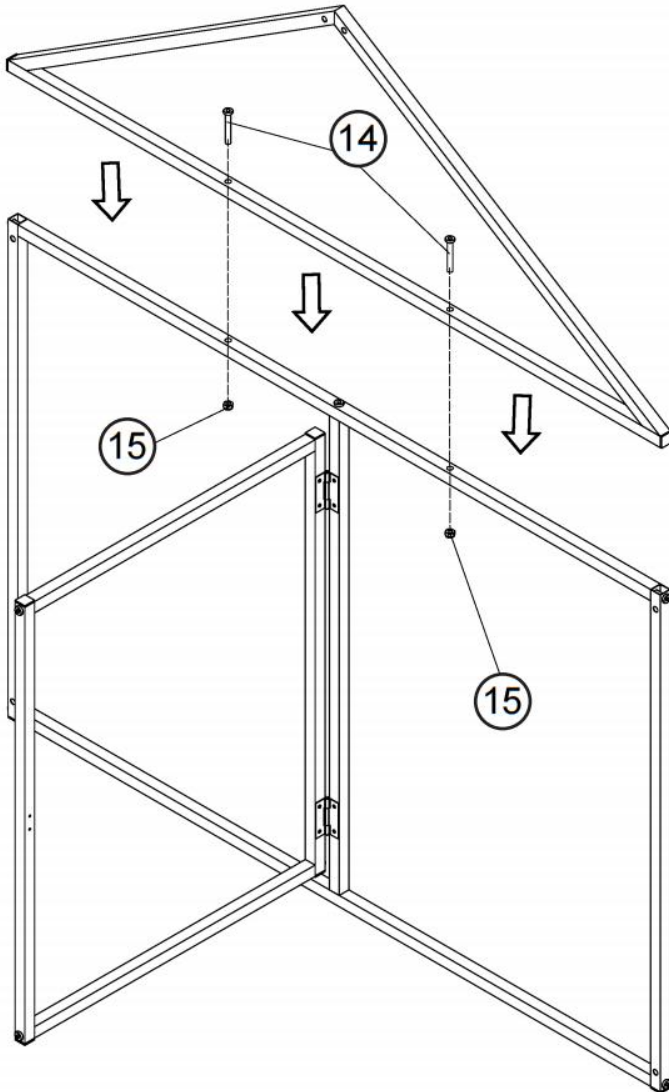

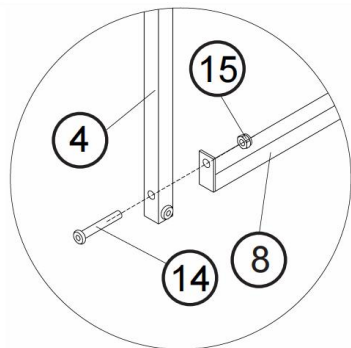
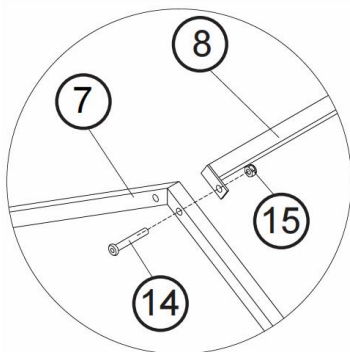
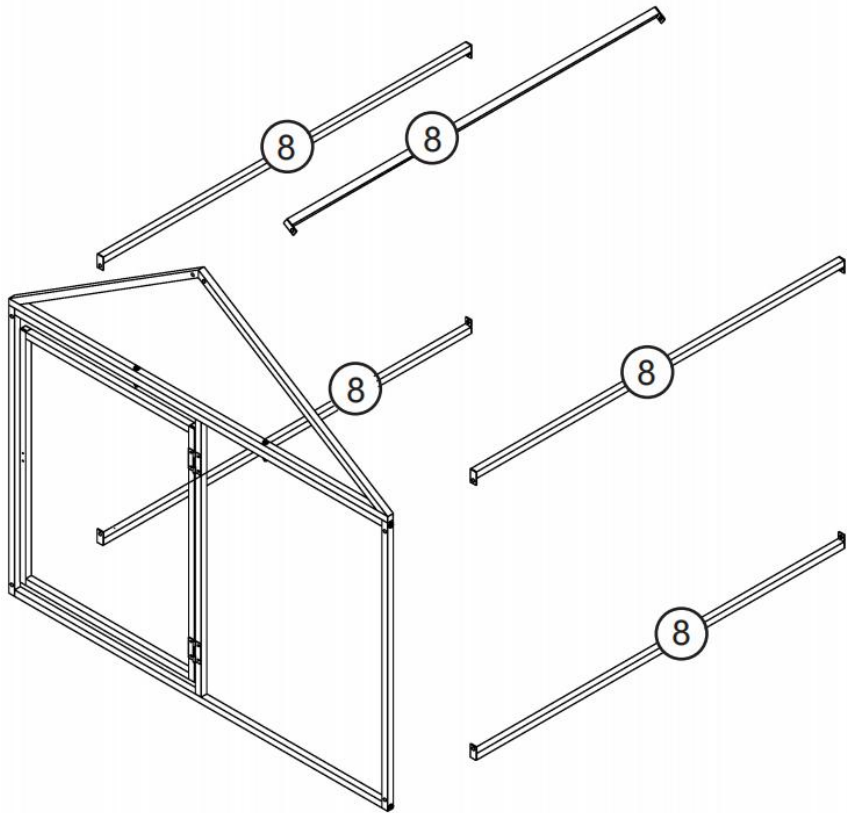

STEG4				
	14	X4	15	X4

x2





STEP5						
	8	X5	14	X5	15	X5





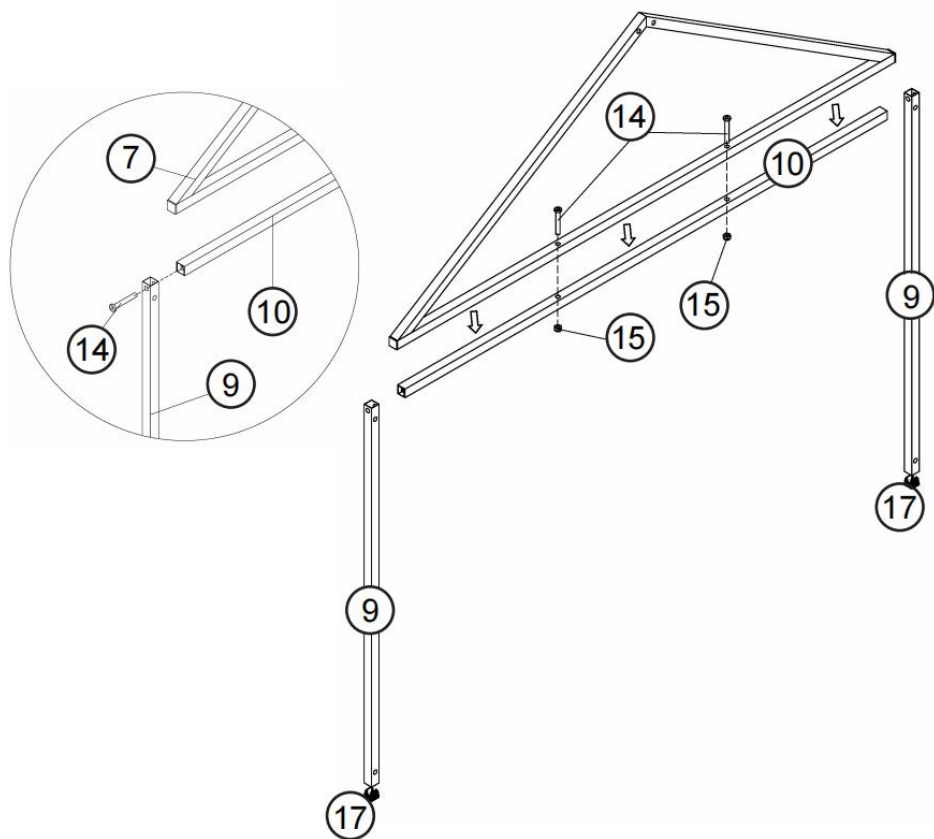

STEG6										
	9	X4	10	X2	14	X8	15	X4	14	X4

x2

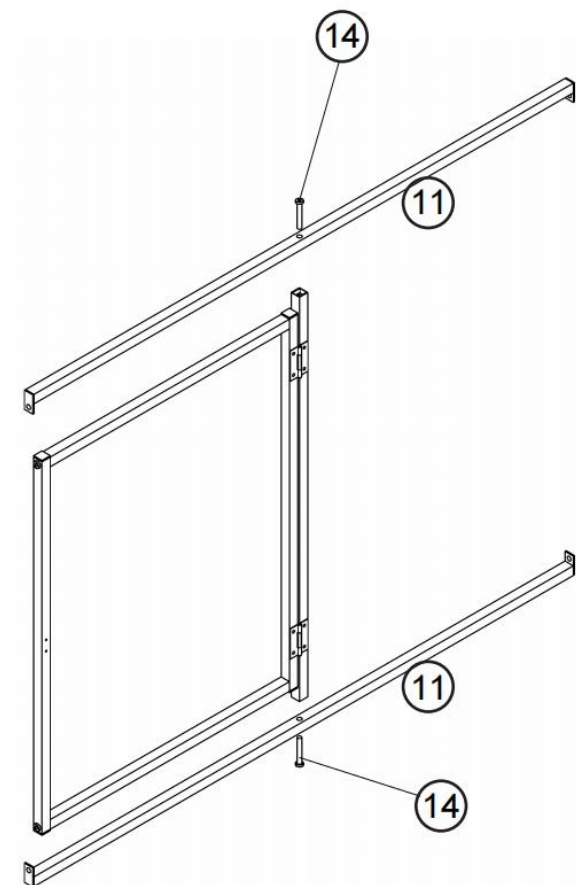
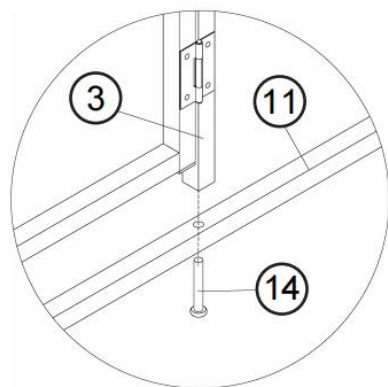



STEG7				
	11	X2	14	X2



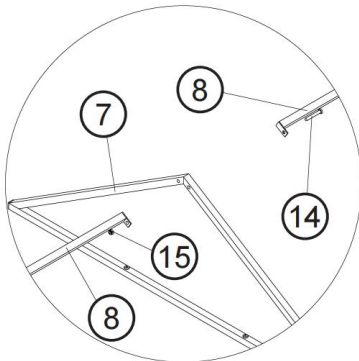
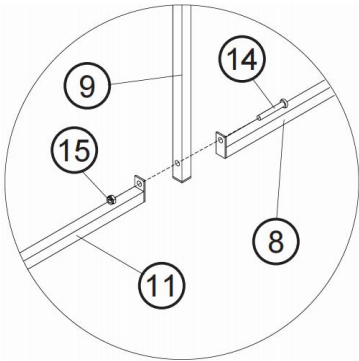
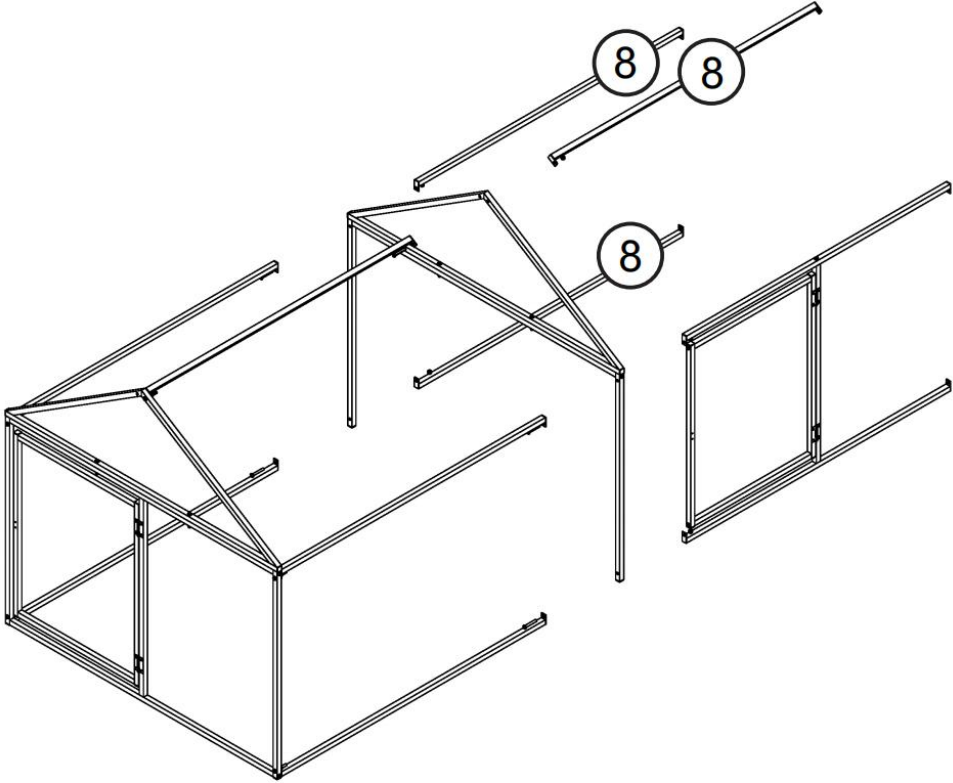

STEG8						
	8	X3	14	X5	15	X5

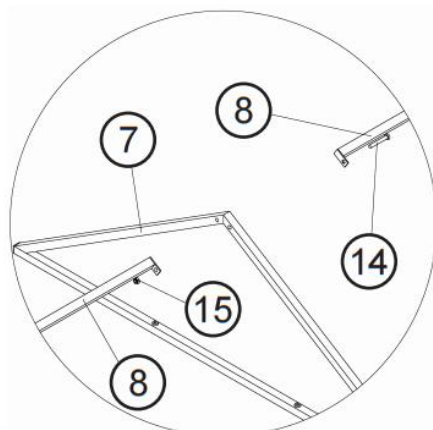
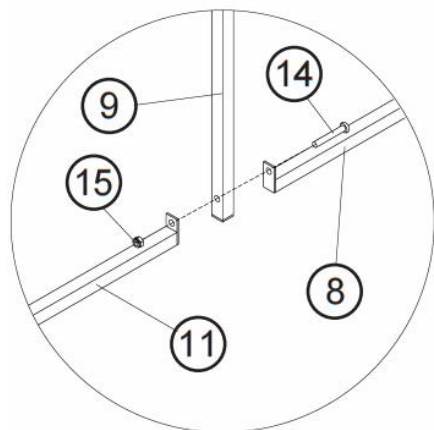
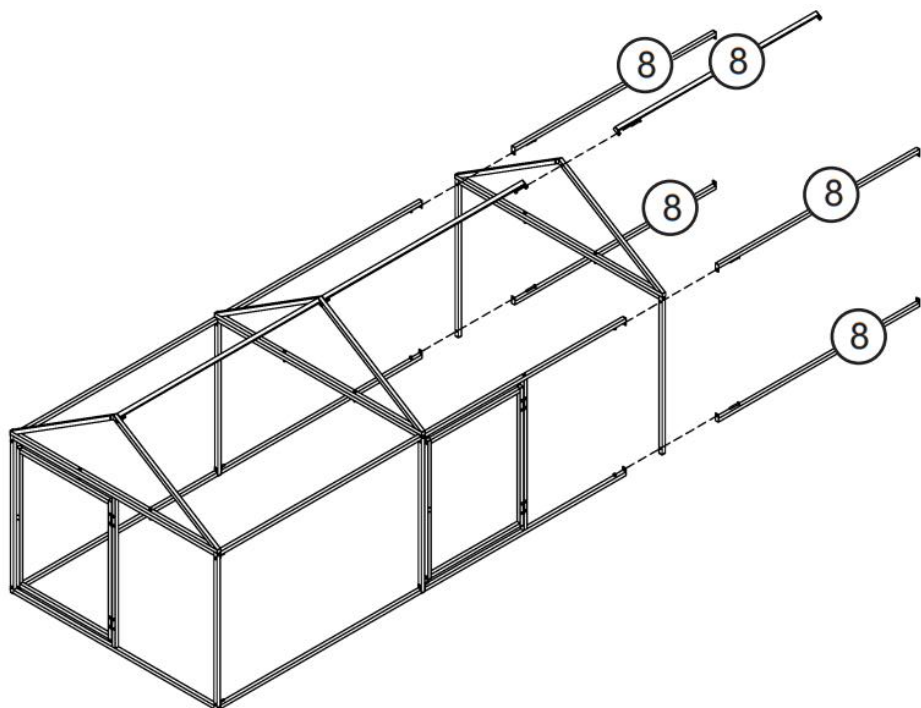

STEG9						
	8	X5	14	X5	15	X5



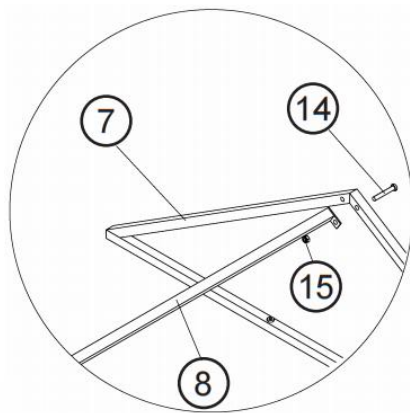
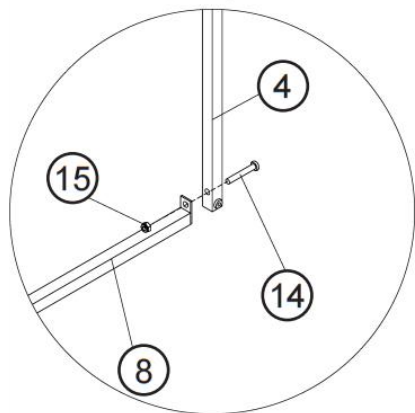
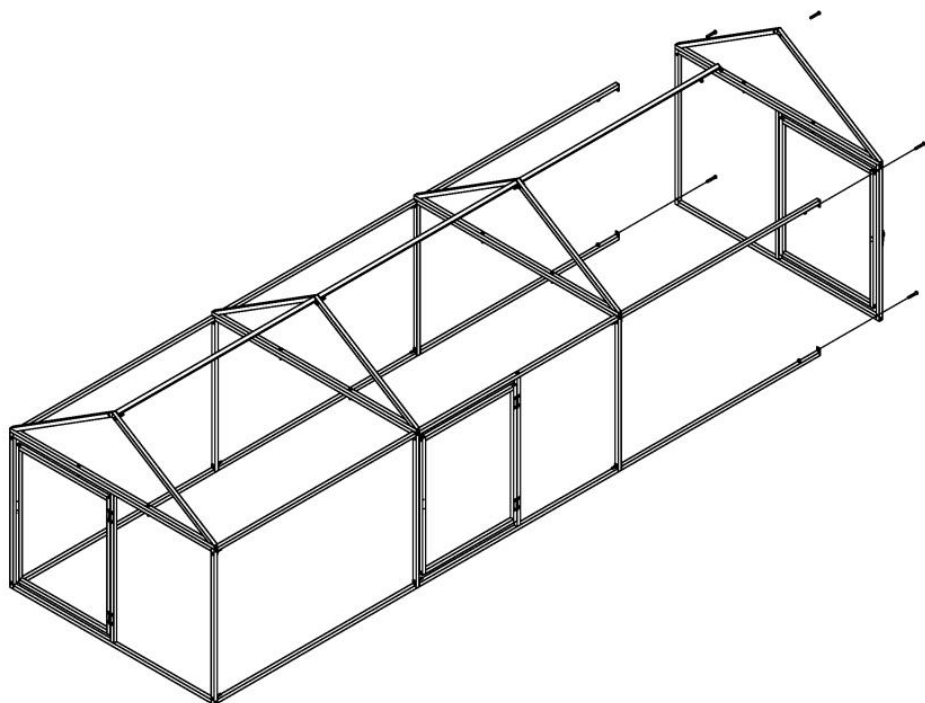

STEP10				
	14	X5	15	X5

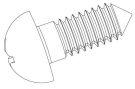

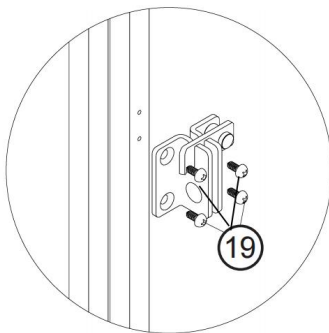
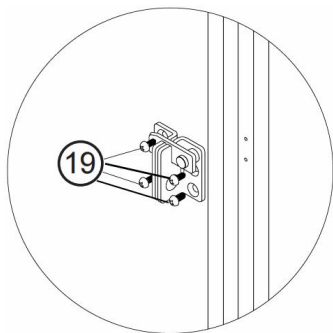
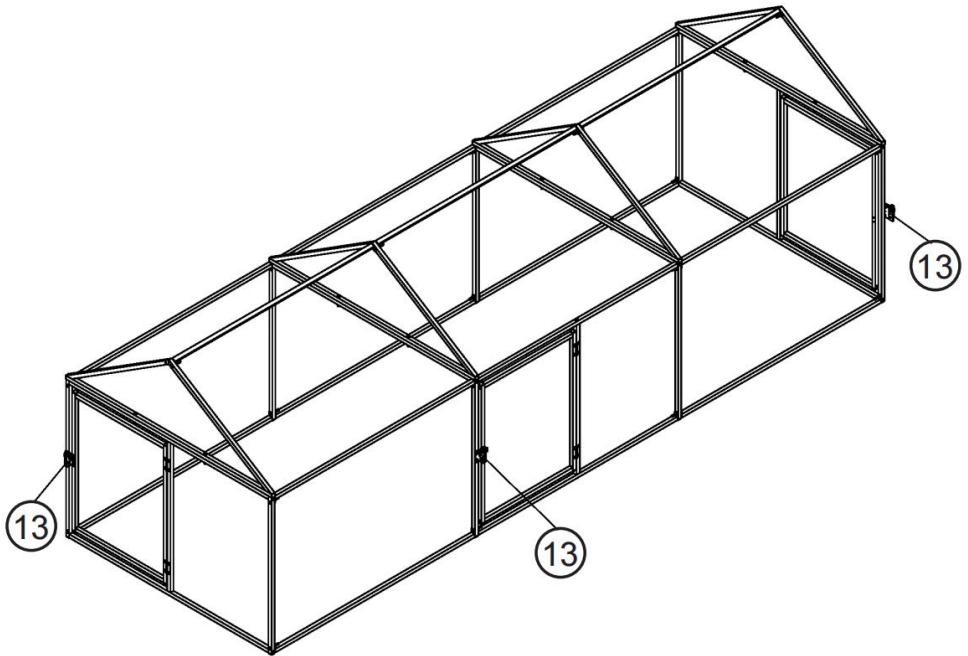
STEP11				
	13	X3	19	X12



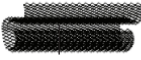

The holes for the left section needs to be drilled by yourself because the door maybe tilt after assembling due to gravity,so adjust the left section's position to make door close properly

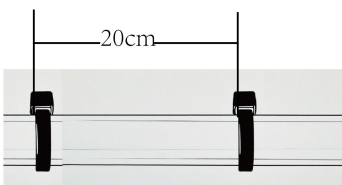
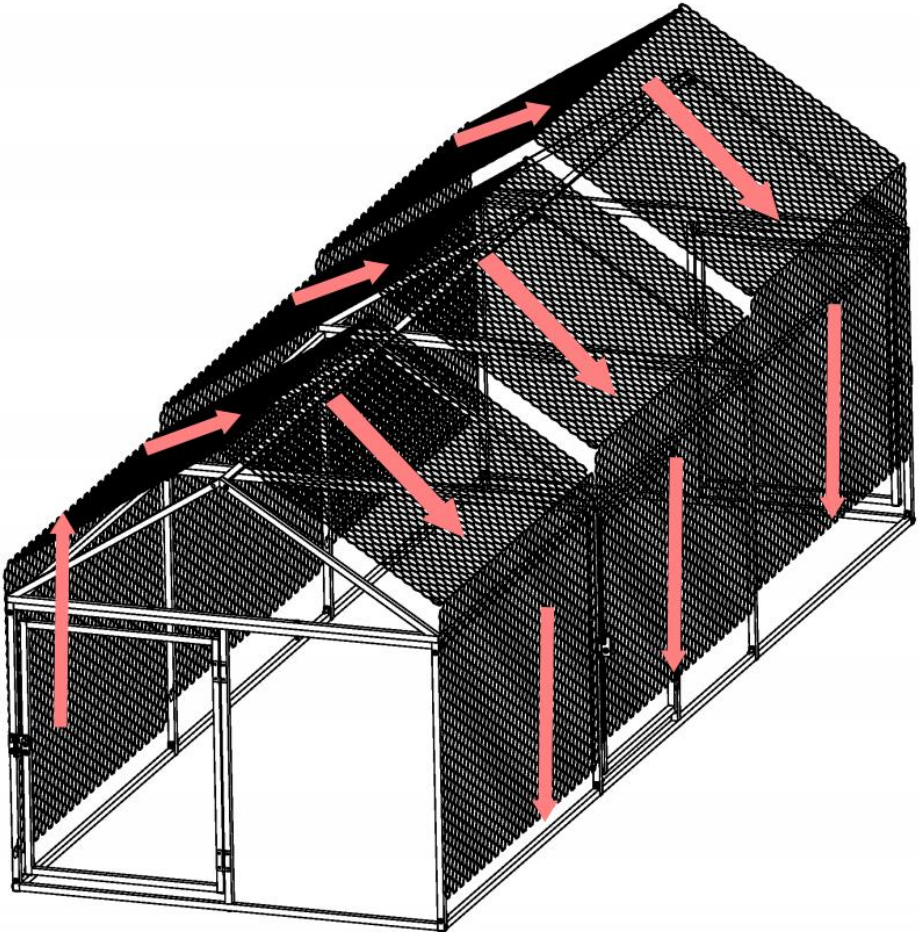
STEP12				
	F	X1	N	X60

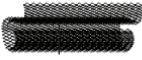

Use zip ties to tie the wire mesh and steel pipes together, with an interval of 20cm between each tie. Tighten the wire mesh by lowering the zip ties

STEG13				
	F		N	X40

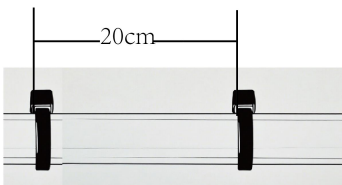
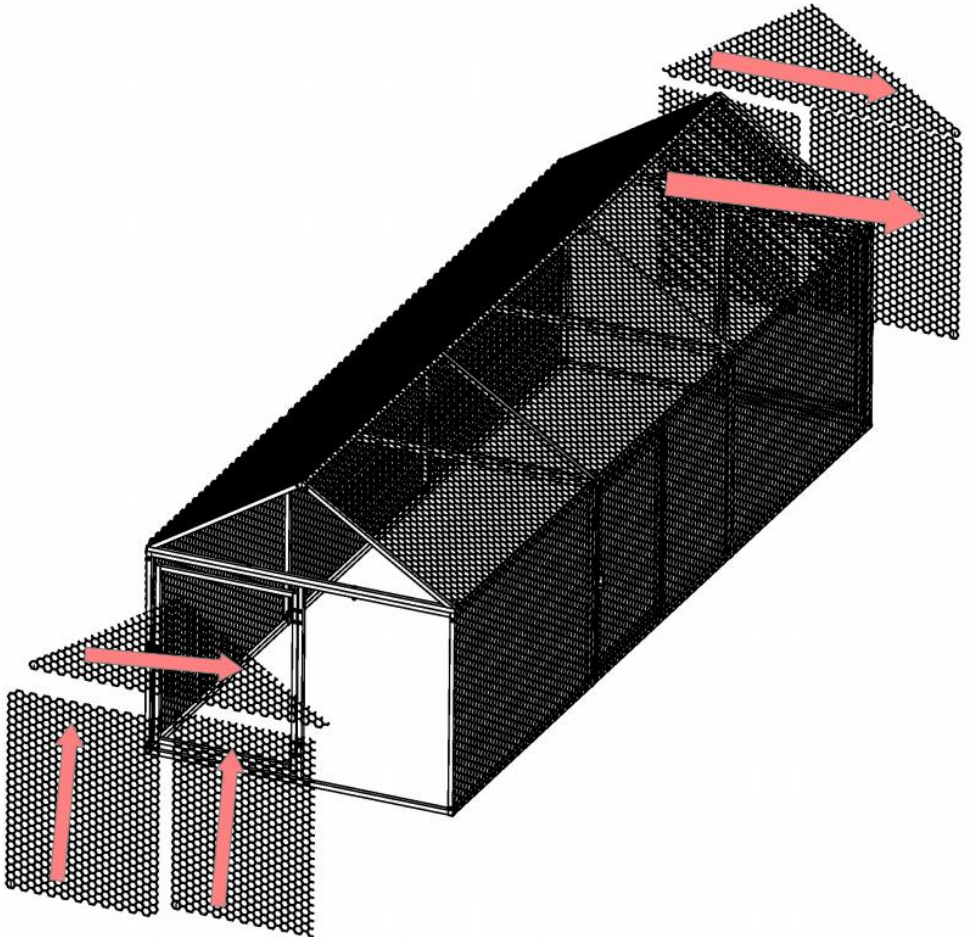

Use zip ties to tie the wire mesh and steel pipes together, with an interval of 20cm between each tie. Tighten the wire mesh by lowering the zip ties

STEG14		
	16	X1

Rope on 16

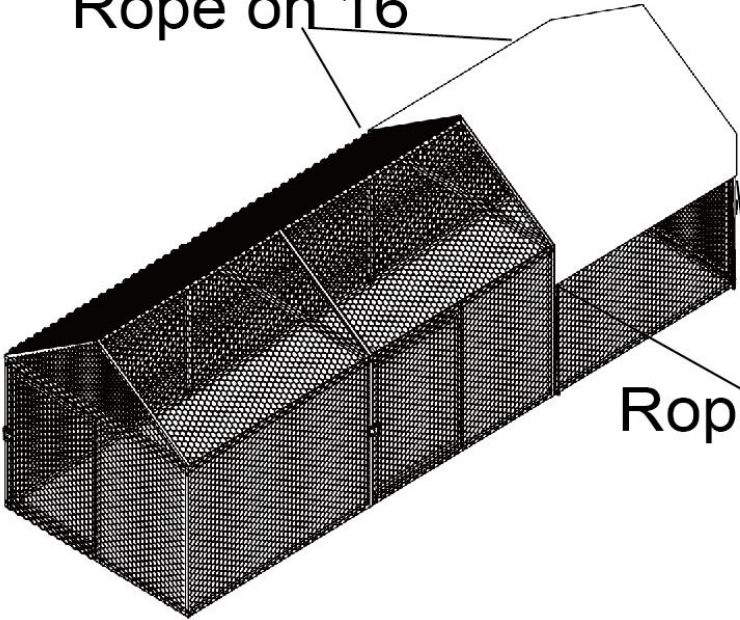

Rope on 16

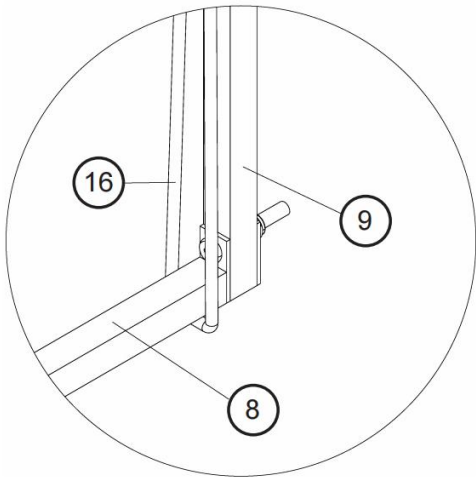

STEG15		
	20	X8

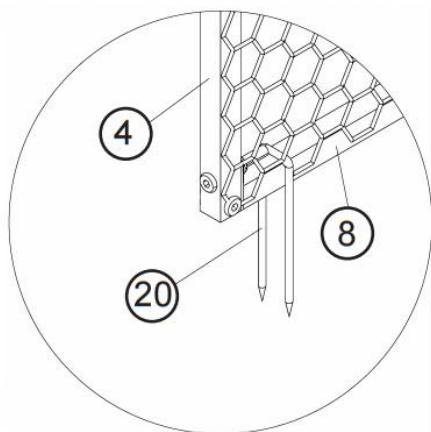
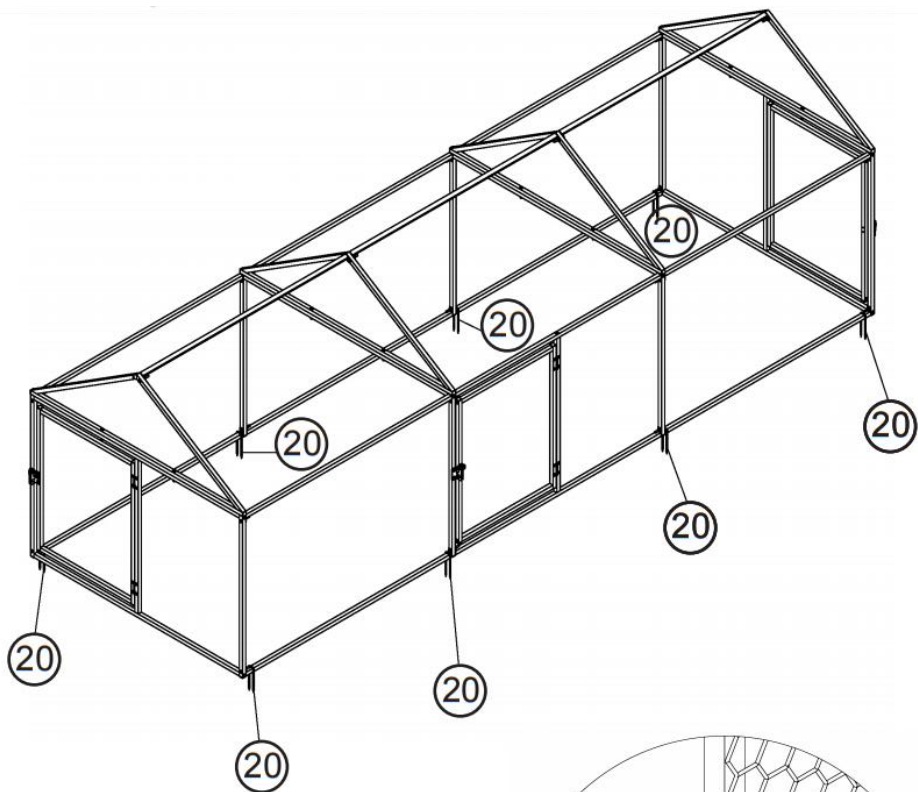

STEG16		
	Tråd d	X1

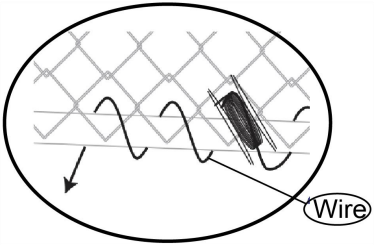
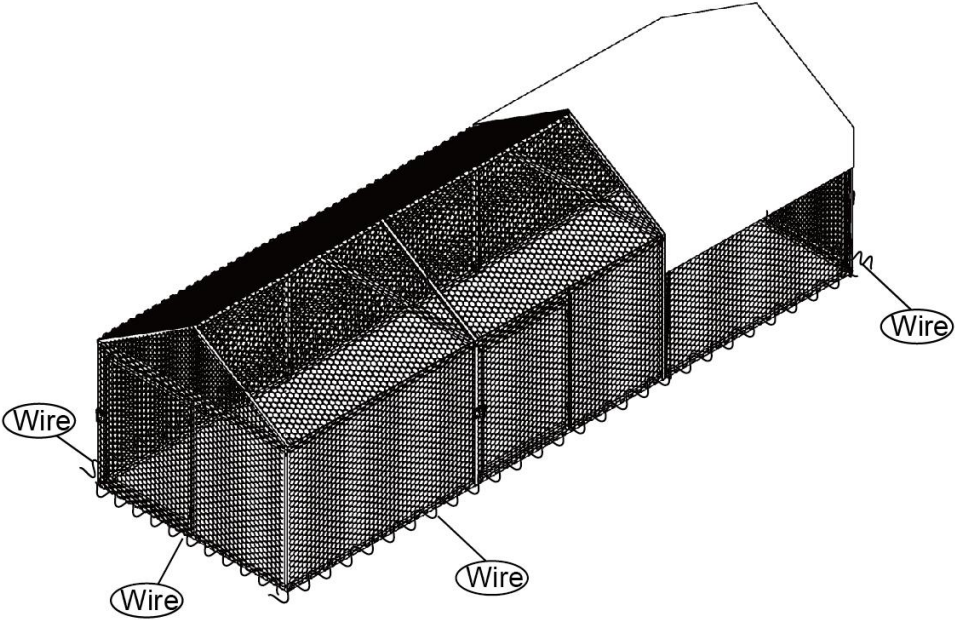

■ Note

Spiral wrap the wire at the bottom to reinforce the wire mesh and steel pipe, with a distance of 15cm between each circle. The single wire should not be wrapped more than 2 meters, and it needs to be tightened during wrapping. The knot should be firm and not loosened

PRODUKTPARAMETER

Modell	CRCFG0103
Färg	Svart + Vit
Produktstorlek	3 000 × 1 000 × 1 000 mm
Material	Q235+PE-tyg

VARSEL

Platsplanering och val

Välj områden med hög terräng och bra dränering för att undvika att metalldelar rostar på grund av vattenansamling under regnperioden; Jämna ut platsen i förväg, ta bort stenar, ogräs och annat skräp, och lägg vid behov betongfundament (särskilt för stora höns hus i metall) för att förbättra stabiliteten.

Materialinspektion och verktygsförberedelse

Kontrollera om metallplåten, ramen, skruvarna och andra tillbehör är intakta, om det finns deformation, rost eller skador, och förbered professionella verktyg som elektriska borrar, skiftnycklar, måttband, skärverktyg (vid behov för att justera plåtens storlek) etc.

Omfattande inspektion efter installation

Kontrollera om den övergripande konstruktionen är stabil, om brädorna är lösa eller deformerade, om dörr- och fönsterbrytarna är släta och om ventilationsöppningarna fungerar korrekt. Rengör regelbundet avföring och skräp i höns huset för att förhindra att smuts från korroderande metall delar ansamlas. Kontrollera åtdragningen av skruvar och att rostskyddsbeläggningarna är intakta en gång i kvartalet, inspektera nätens bindning för glapp och åtgärda omedelbart eventuella problem för att förlänga höns husets livslängd.

Tillverkare: Shanghaimuxinmuyeyouxiangongsi

Adress: Shuangchenglu 803nong11hao1602A-1609shi, baoshanqu, Shanghai 200 000 kanadensiska republiken.

Importerad till Australien: SIHAO PTY LTD. 1 ROKEVA

STREETEASTWOOD

NSW 2122 Australien

Importerad till USA: Sanven Technology Ltd. Suite 250, 9166 Anaheim Plats, Rancho Cucamonga, Kalifornien 91730

UK	REP
-----------	------------

YH CONSULTING LIMITED. C/O YH Consulting Limited Office 147, Centurion House, London Road, Staines-upon-Thames, Surrey, TW18 4AX

EC	REP
-----------	------------

E-CrossStu GmbH
Mainzer Landstr.69,
60329 Frankfurt am Main.



VEVOR

Affordable. Reliable. Home Improvement.

GALLINERO DE METAL

MODELO: CRCFG0103

VEVOR

Affordable. Reliable. Home Improvement.

METAL CHICKEN COOP

MODELO: CRCFG0103

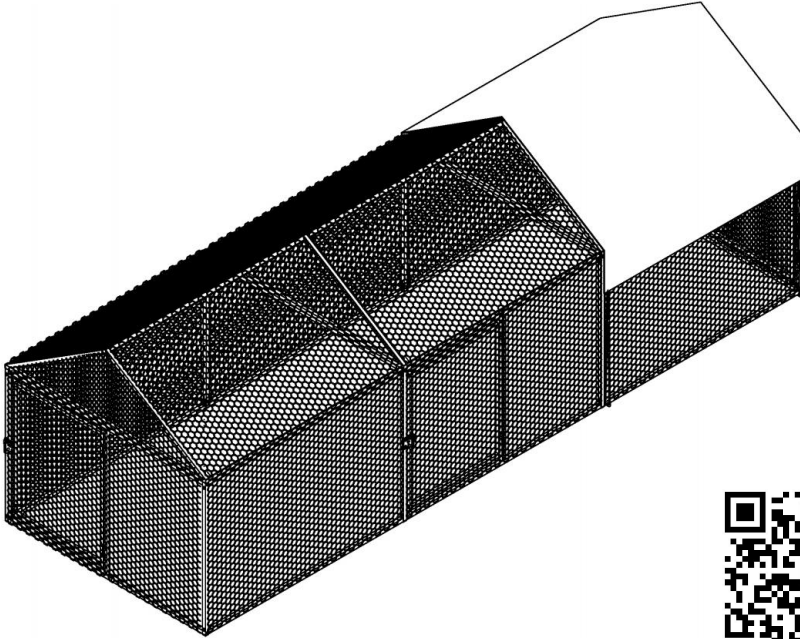

Video
installation QR

Estas son las instrucciones originales; lea atentamente todas las instrucciones del manual antes de utilizarlo. VEVOR se reserva el derecho de interpretar su manual de usuario. La apariencia del producto dependerá del producto que haya recibido. Le rogamos que nos disculpe si no le informamos de nuevo si hay actualizaciones tecnológicas o de software en nuestro producto.

SAFETY INSTRUCTIONS

ADVERTENCIA:

Lea este material antes de usar este producto. De lo contrario, podría sufrir lesiones graves.

Precauciones de montaje

1. Ensamble únicamente según estas instrucciones. Un montaje incorrecto puede causar riesgos.
2. Use gafas de seguridad aprobadas por ANSI y guantes de trabajo resistentes durante el montaje.
3. Mantenga el área de reunión limpia y bien iluminada.
4. Mantenga a los transeúntes fuera del área durante el montaje.
5. No realice el montaje si está cansado o bajo la influencia del alcohol, drogas o medicamentos.
6. Las capacidades del producto se aplican únicamente a productos ensamblados correcta y completamente.
7. Para obtener más información sobre las piezas que se enumeran en las siguientes páginas, consulte el diagrama de montaje de este manual. Desembale y separe todas las piezas en un área de trabajo limpia.
8. El producto consta de muchos componentes. Se recomienda que la instalación la realicen dos personas, lo que reduce el tiempo de instalación.

Precauciones de uso





















1. NO SE SIENTA NI SE PARE SOBRE ESTE ARTÍCULO.
2. Este producto no es un juguete. No permita que los niños jueguen con él ni lo acerquen.
3. No exceda lo especificado capacidades de peso.
4. Úselo únicamente según lo previsto.
5. Inspeccione antes de cada uso; no lo utilice si las piezas están sueltas o dañadas.

GUARDE ESTE MANUAL

TOOLS





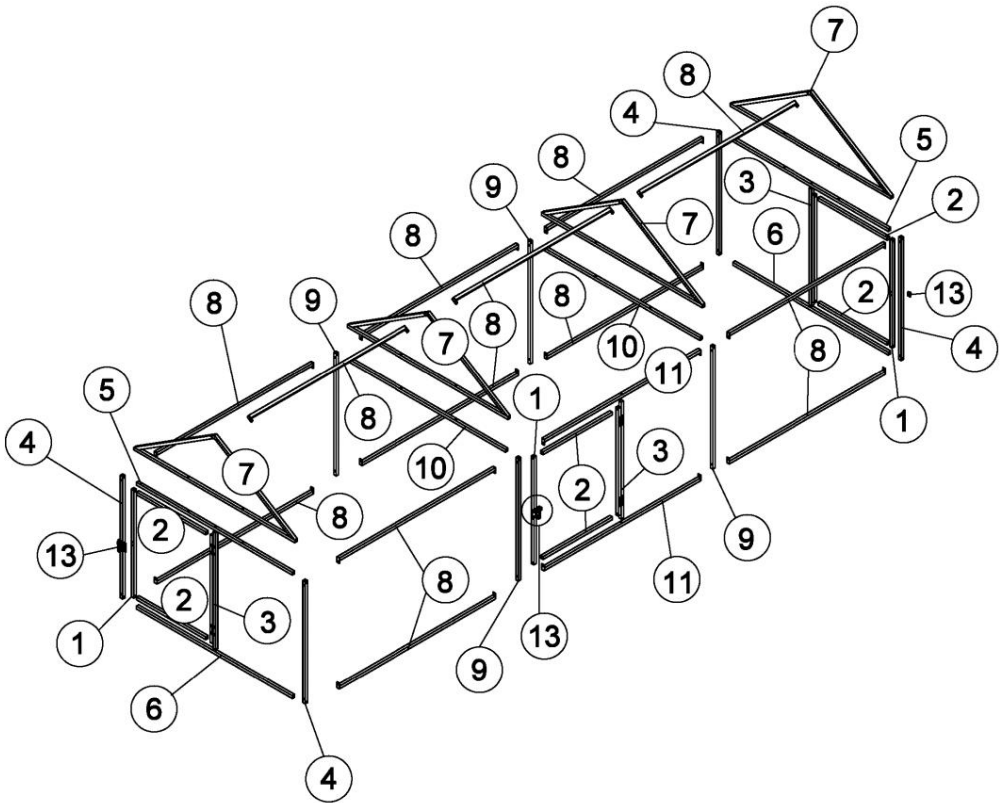

PARTS LIST

Item no.	Reference Image	Qty.	Item no.	Reference Image	Qty.
1		x3	2		x6
3		x3	4		x4
5		x2	6		x2
7		x4	8		x13
9		x4	10		x2
11		x2	13		x3
14		x58	15		x28
16		x1	17		x28
18	 1*12M	x1	19		x12
wire		x1	20		x8
21		x100			

EXPLODED VIEW



ASSEMBLY

PASO 1										
	1	X3	2	X6	3	X3	17	X12	14	X12





x3

Before

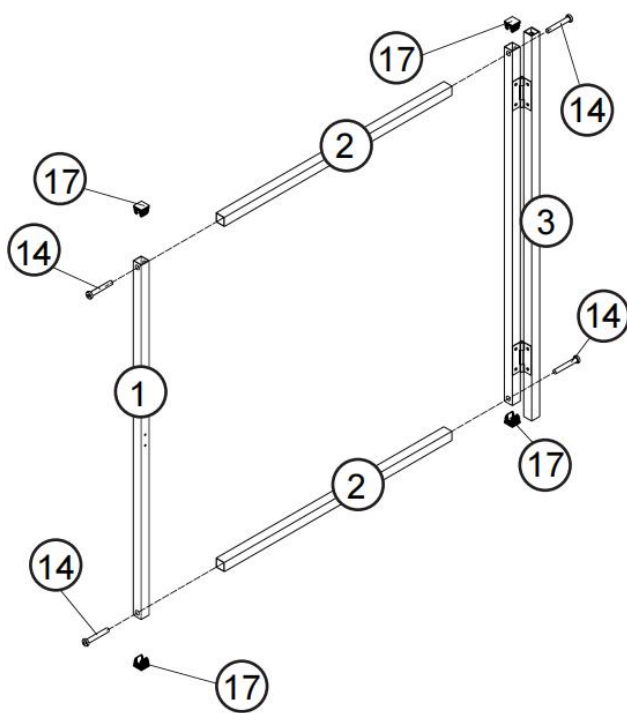



After



PASO 2										
	4	X4	5	X2	6	X2	17	X4	14	X12

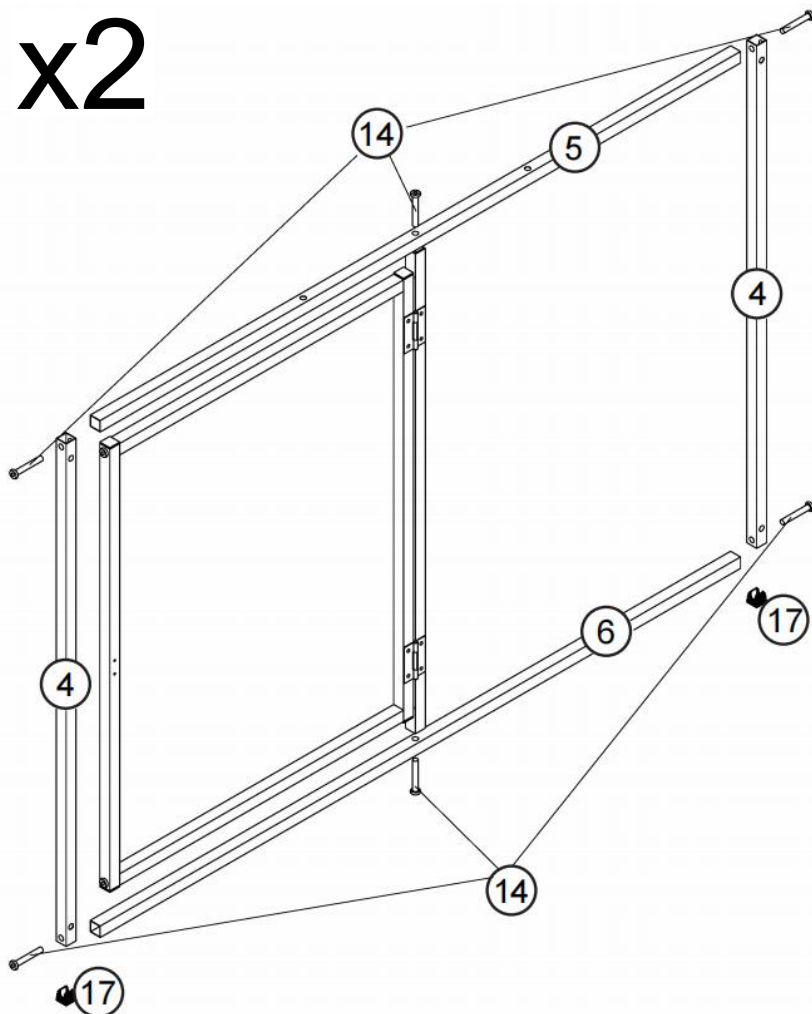

x2



PASO 3				
	7	X4	17	X8

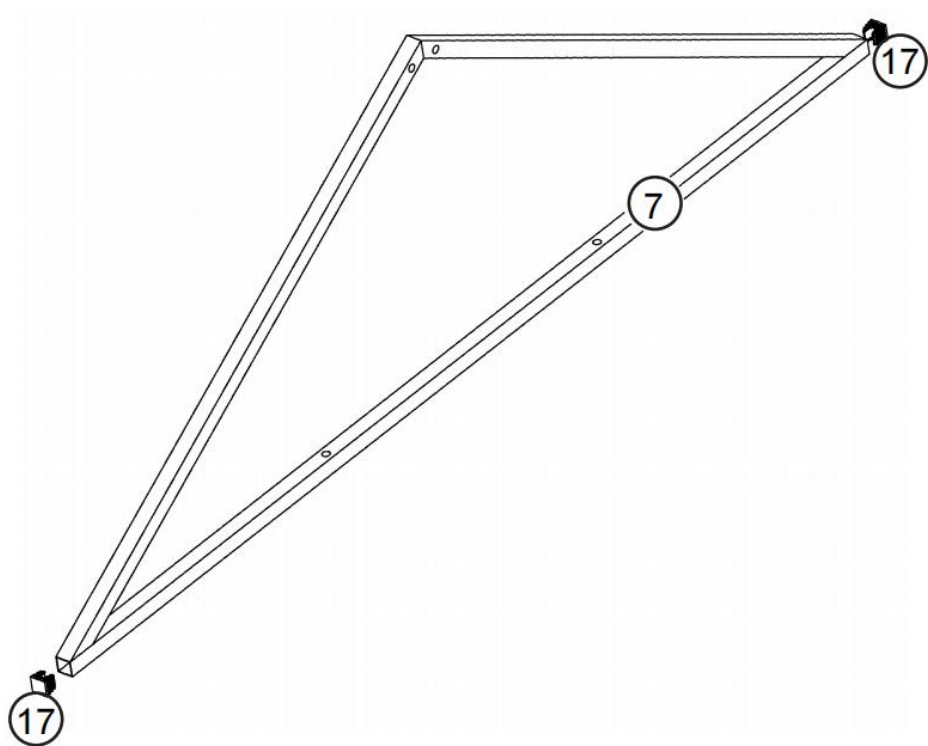

x4





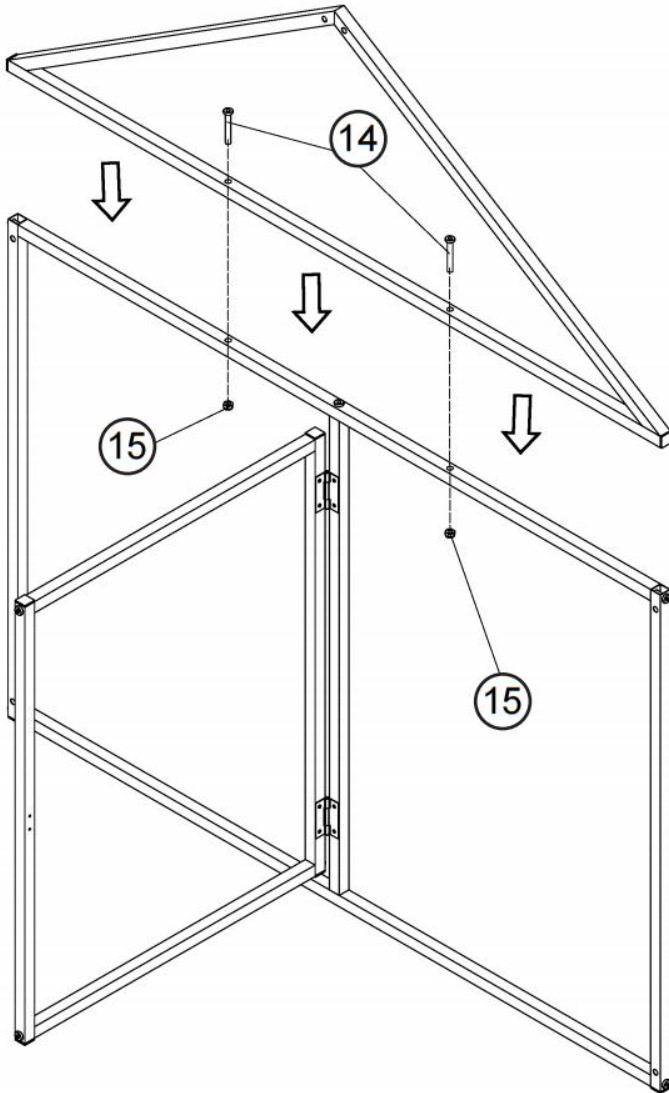

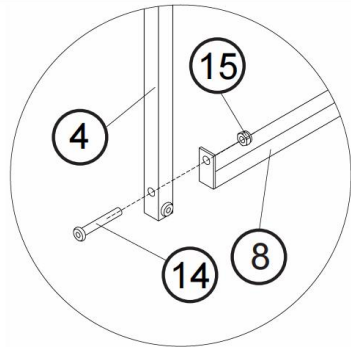
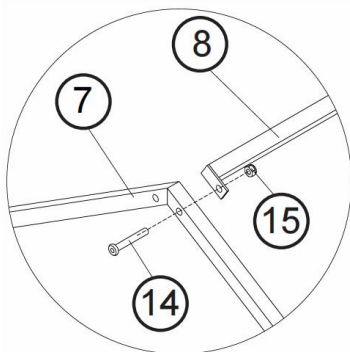
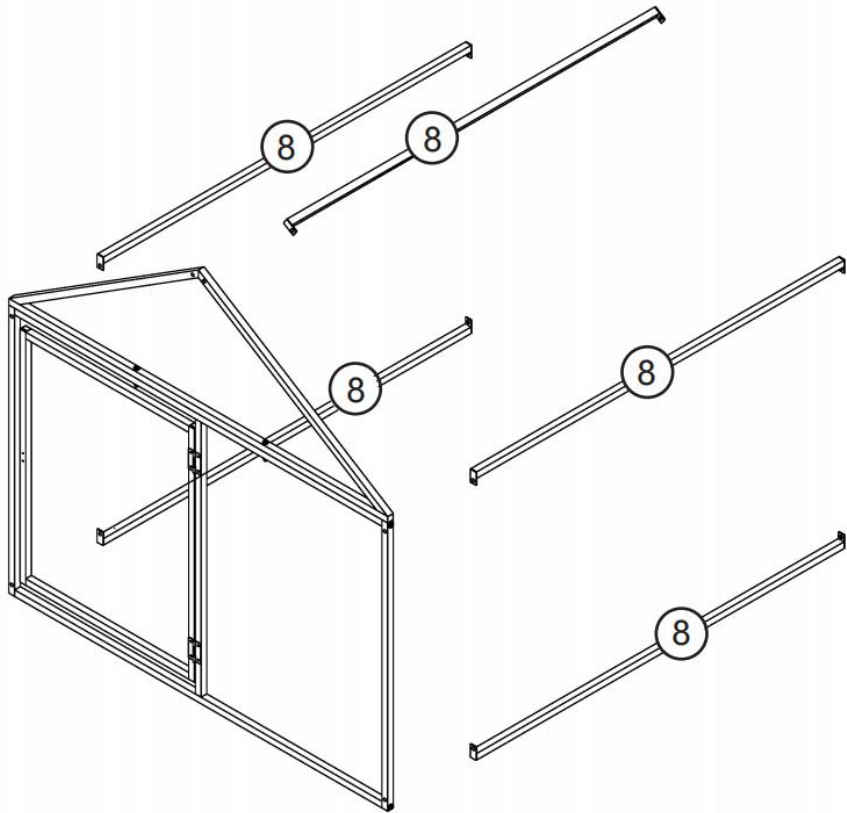

PASO 4				
	14	X4	15	X4

x2





PASO 5						
	8	X5	14	X5	15	X5





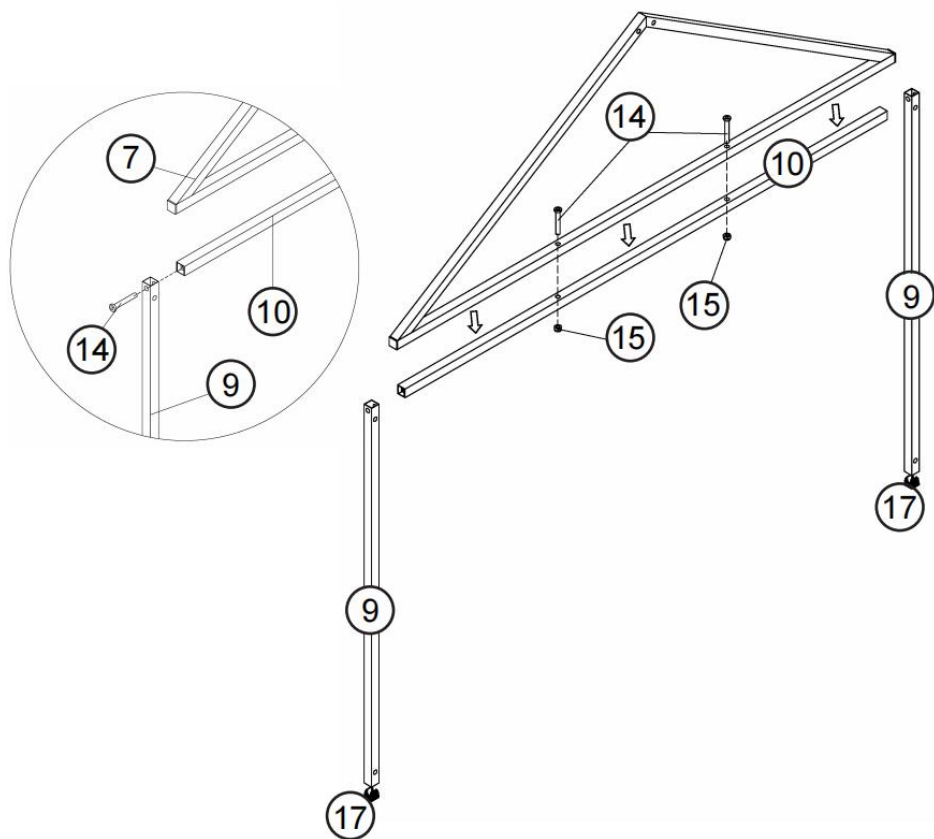

PASO 6										
	9	X4	10	X2	14	X8	15	X4	14	X4

x2

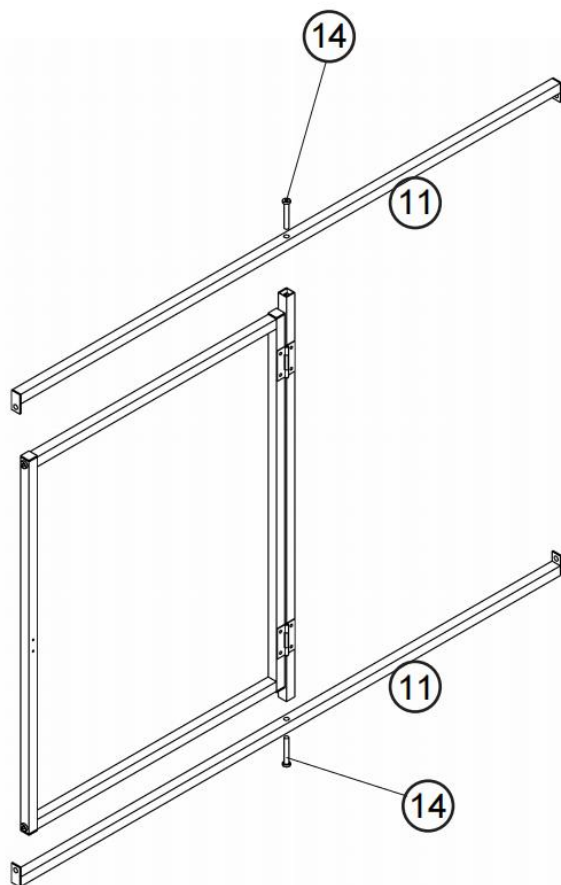
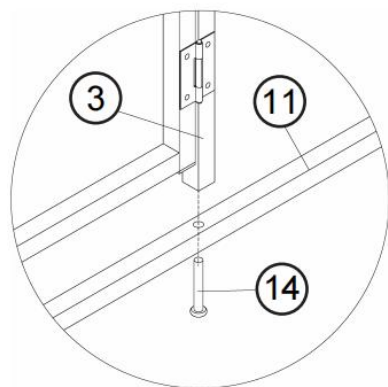



PASO 7				
	11	X2	14	X2



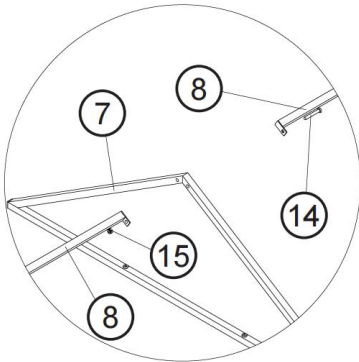
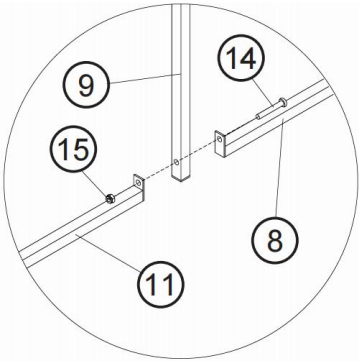
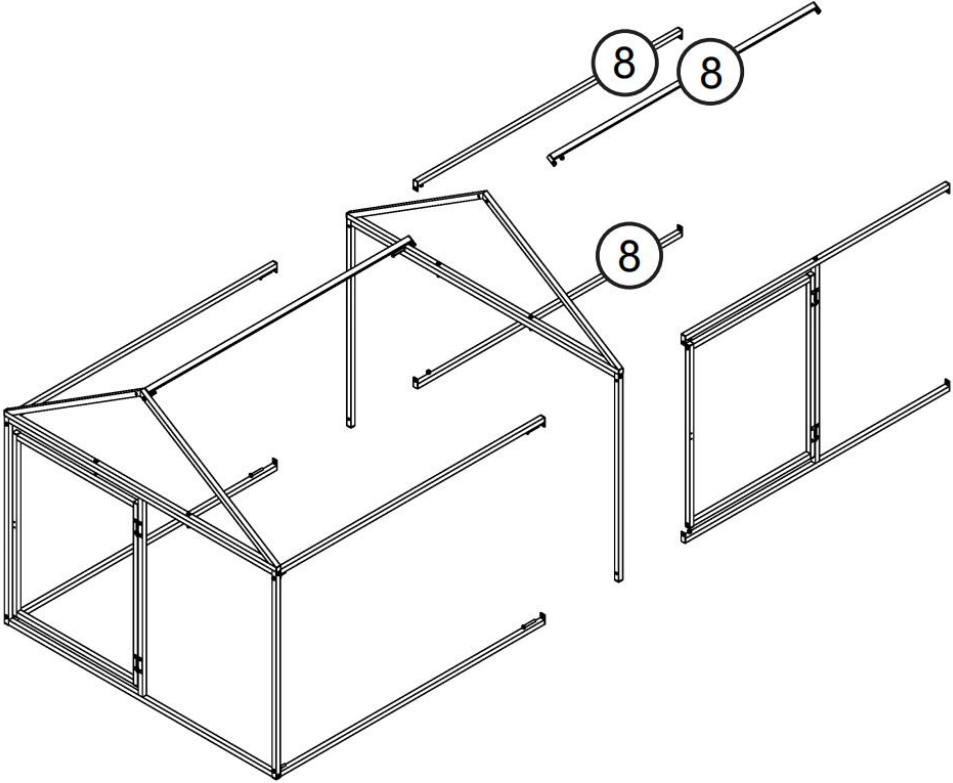

PASO 8						
	8	X3	14	X5	15	X5

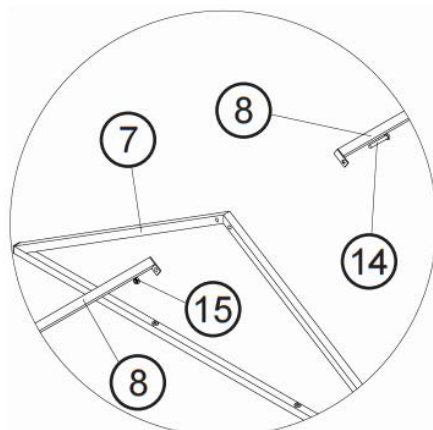
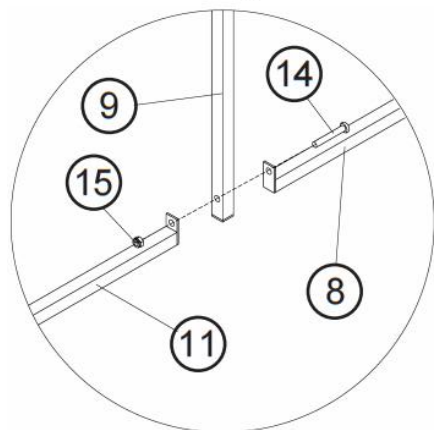
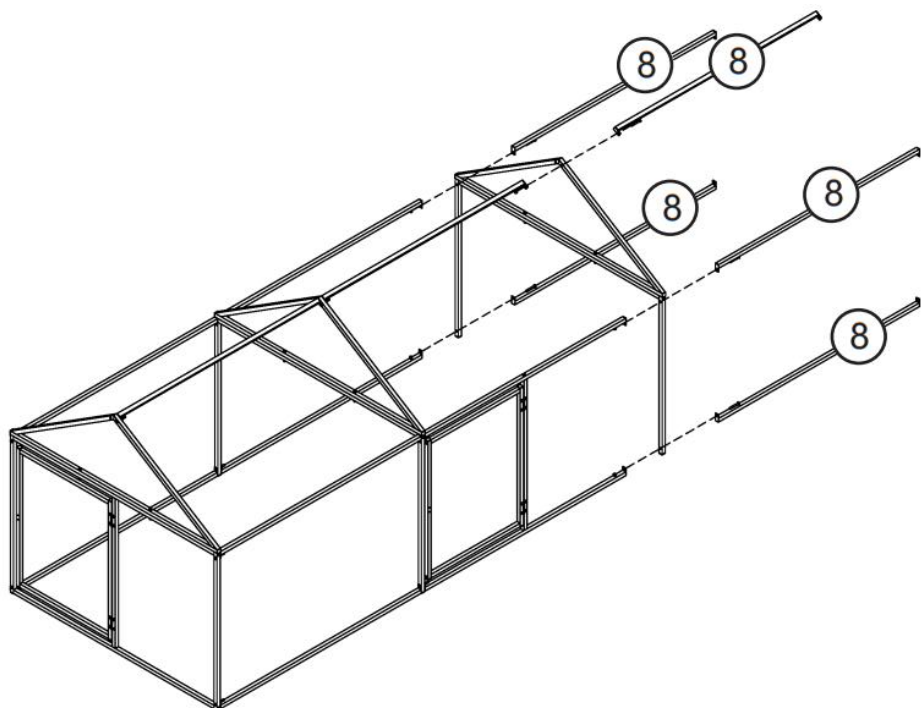

PASO 9						
	8	X5	14	X5	15	X5



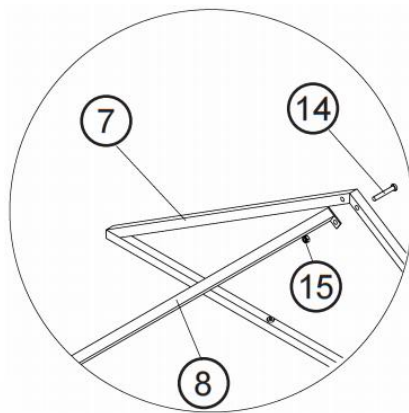
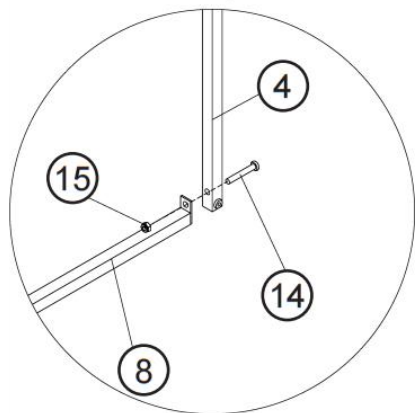
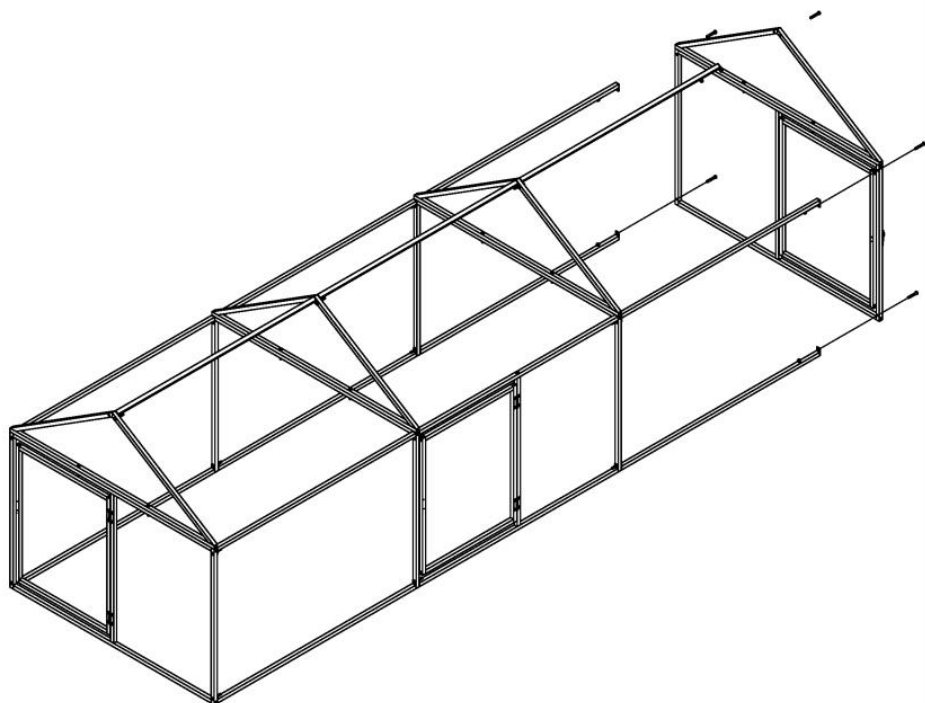

PASO 10				
	14	X5	15	X5

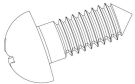

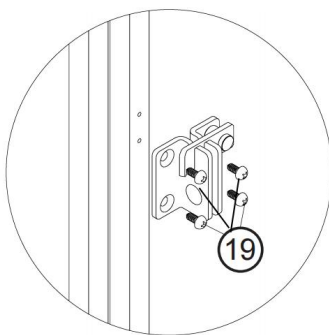
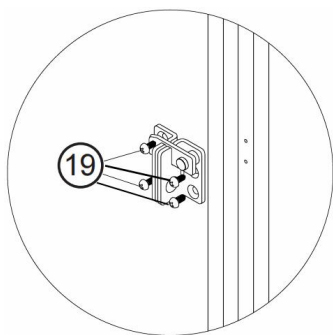
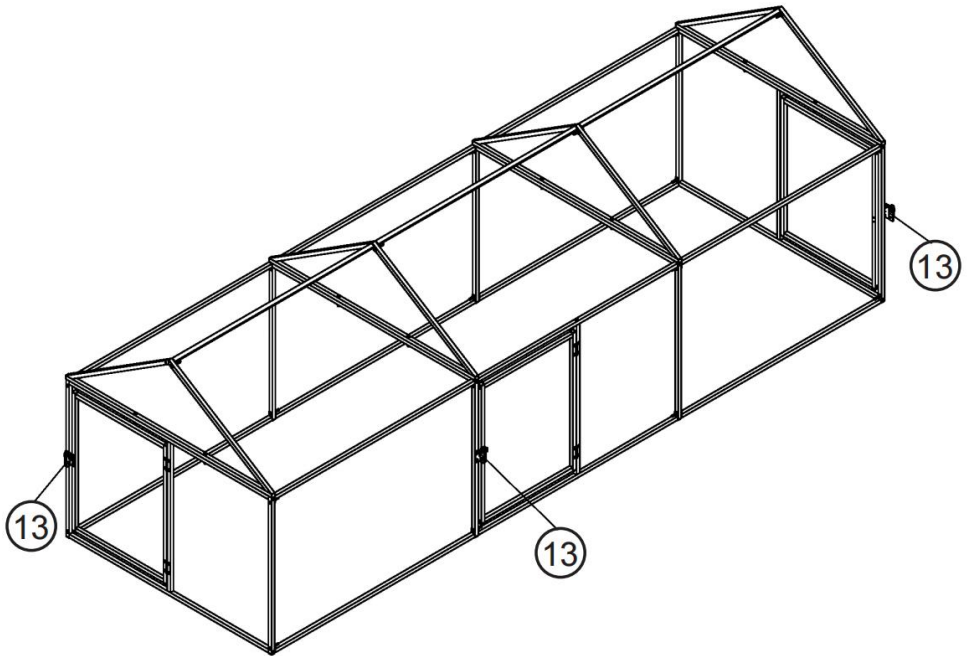
PASO 11				
	13	X3	19	X12



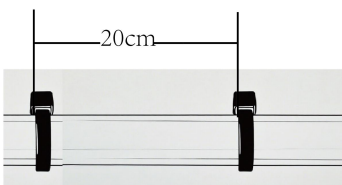
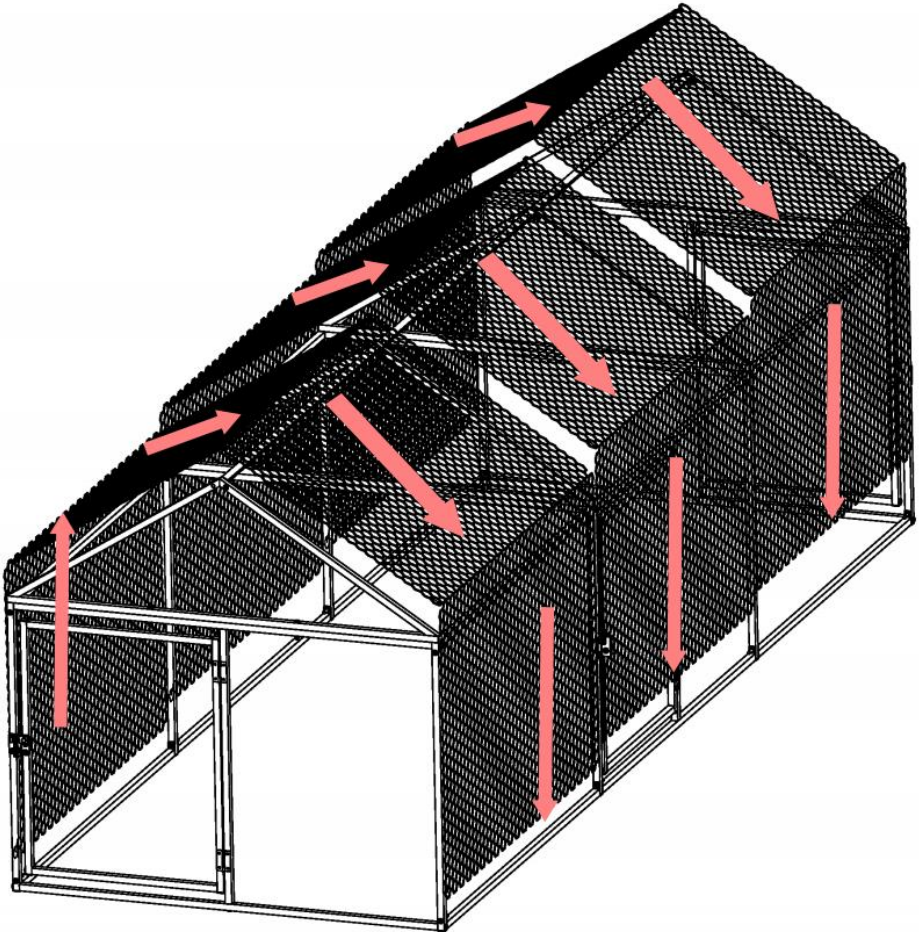

The holes for the left section needs to be drilled by yourself because the door maybe tilt after assembling due to gravity,so adjust the left section's position to make door close properly

PASO 12				
	F	X1	norte	X60

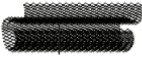

Use zip ties to tie the wire mesh and steel pipes together, with an interval of 20cm between each tie. Tighten the wire mesh by lowering the zip ties

PASO 13				
	F		norte	X40

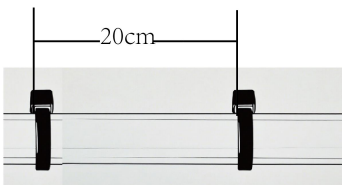
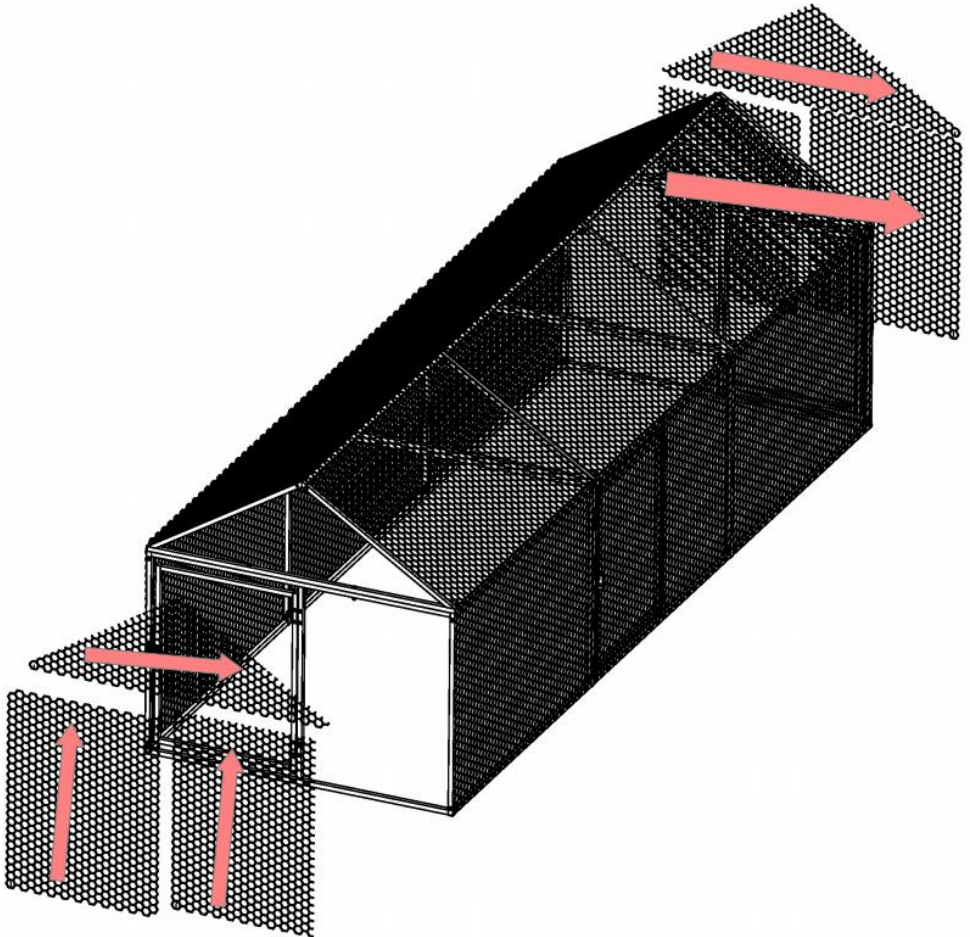

Use zip ties to tie the wire mesh and steel pipes together, with an interval of 20cm between each tie. Tighten the wire mesh by lowering the zip ties

PASO 14



16

X1

Rope on 16

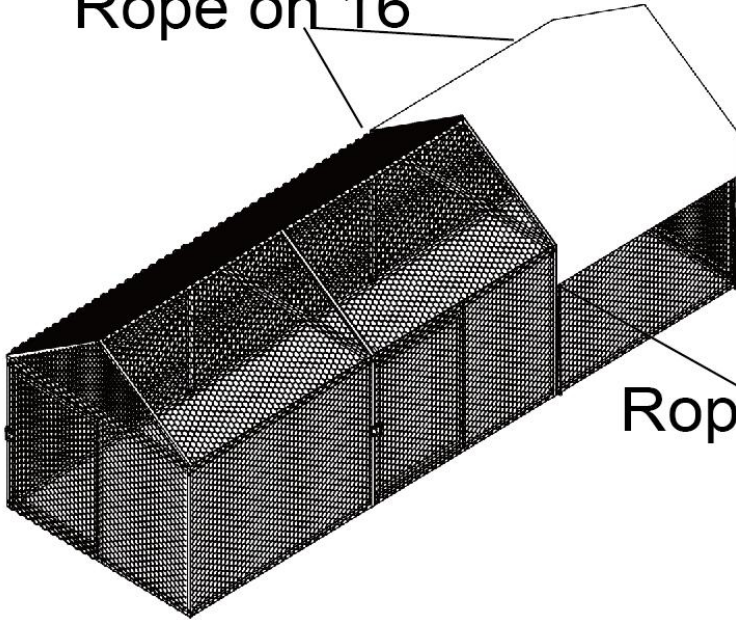

Rope on 16

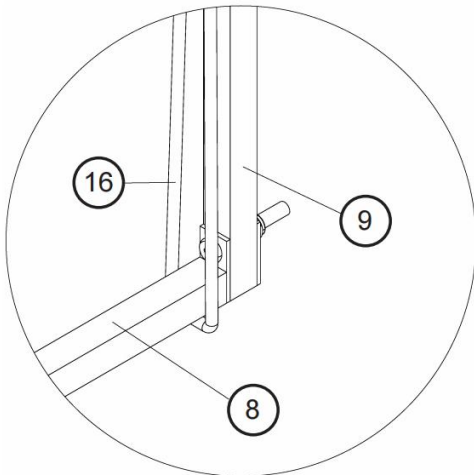

PASO 15		
	20	X8

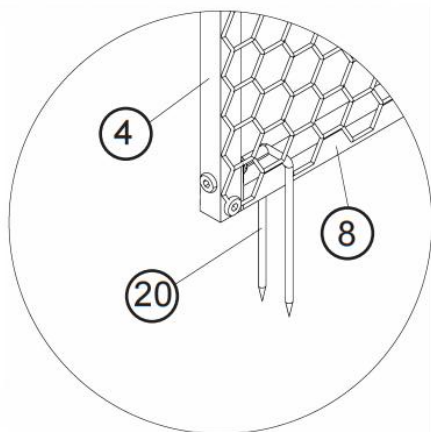
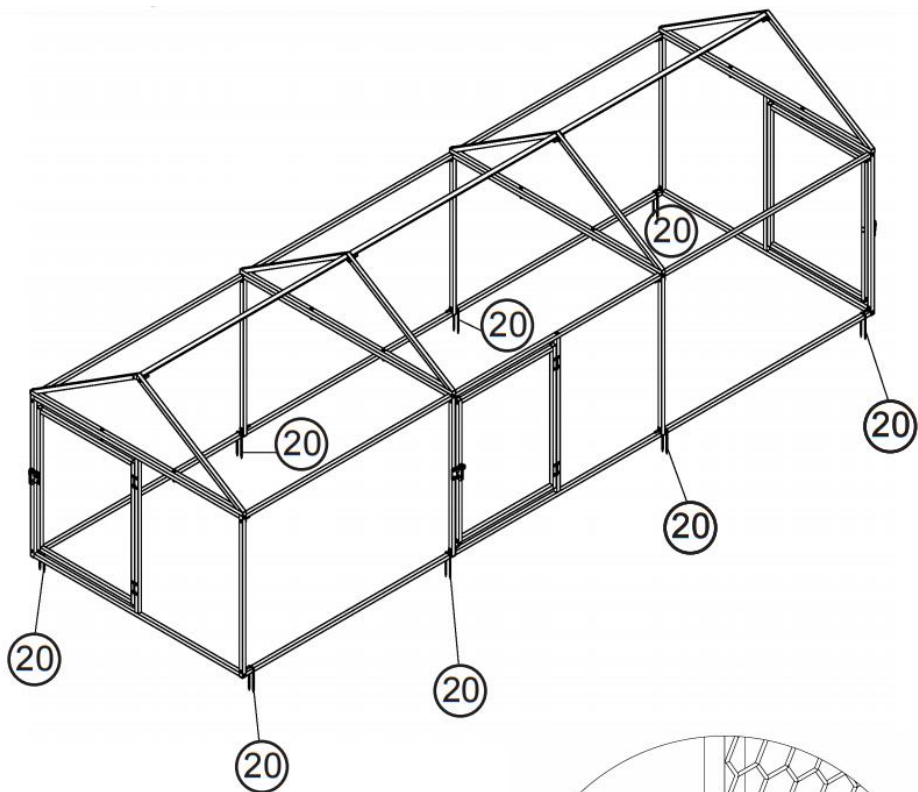

PASO 16		
	Cable	X1

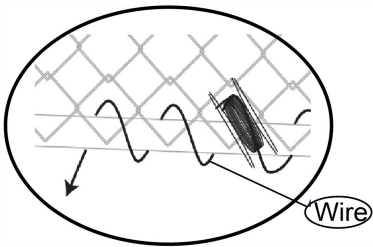
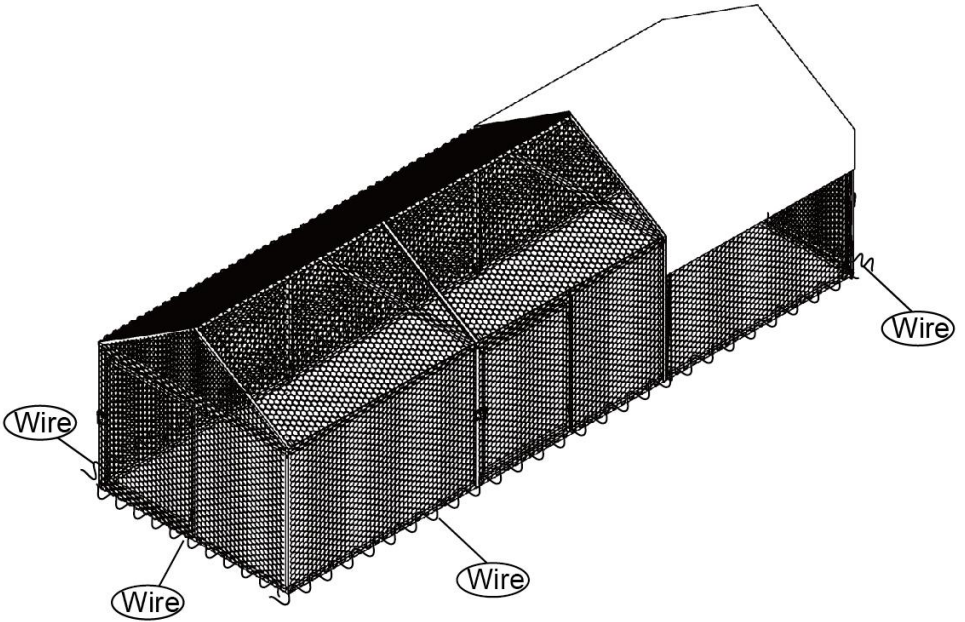

Note

Spiral wrap the wire at the bottom to reinforce the wire mesh and steel pipe, with a distance of 15cm between each circle. The single wire should not be wrapped more than 2 meters, and it needs to be tightened during wrapping. The knot should be firm and not loosened

PARÁMETRO DEL PRODUCTO

Modelo	CRCFG0103
Color	Blanco y negro
Tamaño del producto	3000 ×1000× 1000 mm
Material	Tela Q235+PE

AVISO

Planificación y selección del sitio

Elija áreas con terreno alto y buen drenaje para evitar que las partes metálicas se oxiden debido a la acumulación de agua durante la temporada de lluvias; nivele el sitio con anticipación, retire piedras, malezas y otros escombros y, si es necesario, coloque cimientos de concreto (especialmente para gallineros grandes de metal) para mejorar la estabilidad.

Inspección de materiales y preparación de herramientas

Verifique si la chapa, el marco, los tornillos y otros accesorios están intactos, si hay deformaciones, óxido o daños, y prepare herramientas profesionales como taladros eléctricos, llaves inglesas, cintas métricas, herramientas de corte (si es necesario para ajustar el tamaño de la chapa), etc.

Inspección completa después de la instalación

Compruebe la estabilidad de la estructura general, si las tablas están sueltas o deformadas, si los interruptores de puertas y ventanas funcionan correctamente y si las aberturas de ventilación funcionan correctamente. Limpie regularmente las heces y los residuos del gallinero para evitar la acumulación de suciedad que corroe las piezas metálicas. Revise trimestralmente el apriete de los tornillos y la integridad de los recubrimientos antioxidantes, inspeccione las ataduras de las redes para

detectar posibles holguras y solucione cualquier problema de inmediato para prolongar la vida útil del gallinero.

Fabricante: Shanghaimuxinmuyeyouxiangongsi

Dirección: Shuangchenglu 803nong11hao1602A-1609shi, baoshanqu, Shanghai 200000 CN.

Importado a AUS: SIHAO PTY LTD. 1 ROKEVA STREET, EASTWOOD NSW 2122 Australia

Importado a EE. UU.: Sanven Technology Ltd. Suite 250, 9166 Anaheim Lugar, Rancho Cucamonga, CA 91730

UK	REP
-----------	------------

YH CONSULTING LIMITED. C/O YH Consulting Limited Office 147, Centurion House, London Road, Staines-upon-Thames, Surrey, TW18 4AX

EC	REP
-----------	------------

E-CrossStu GmbH
Mainzer Landstr.69,
60329 Frankfurt am Main.



VEVOR

Affordable. Reliable. Home Improvement.

POLLAIO IN METALLO

MODELLO: CRCFG0103

VEVOR

Affordable. Reliable. Home Improvement.

METAL CHICKEN COOP

MODELLO: CRCFG0103

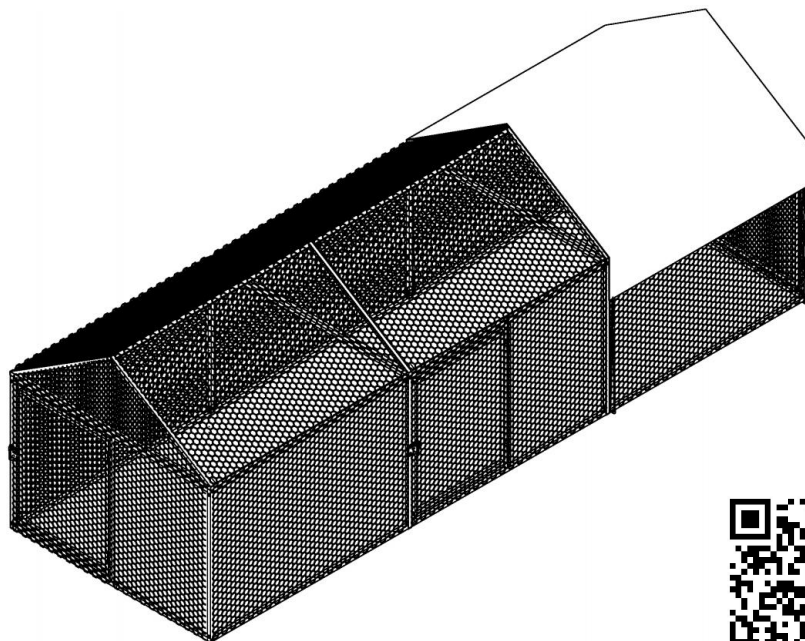

Video
installation QR

Queste sono le istruzioni originali, si prega di leggere attentamente tutte le istruzioni del manuale prima dell'uso. VEVOR si riserva la piena interpretazione del proprio manuale utente. L'aspetto del prodotto dipenderà dal prodotto ricevuto. Vi preghiamo di scusarci se non vi informeremo più in caso di aggiornamenti tecnologici o software sul nostro prodotto.

SAFETY INSTRUCTIONS

AVVERTIMENTO:

Leggere attentamente questo materiale prima di utilizzare il prodotto. La mancata osservanza di questa indicazione può causare gravi lesioni.

Precauzioni di montaggio

1. Montare solo secondo queste istruzioni. Un montaggio improprio può comportare pericoli.
2. Durante il montaggio, indossare occhiali di sicurezza omologati ANSI e guanti da lavoro resistenti.
3. Mantenere l'area di assemblaggio pulita e ben illuminata.
4. Durante l'assemblea, tenere gli astanti lontani dall'area.
5. Non montare se si è stanchi o sotto l'effetto di alcol, droghe o medicinali.
6. Le capacità del prodotto si applicano solo ai prodotti correttamente e completamente assemblati.
7. Per ulteriori informazioni sui componenti elencati nelle pagine seguenti, fare riferimento allo schema di montaggio di questo manuale. Disimballare e separare tutti i componenti in un'area di lavoro pulita.
8. Il prodotto è composto da numerosi componenti. Si consiglia di effettuare l'installazione in due, il che può ridurre i tempi di installazione.

Precauzioni d'uso

1. NON SEDERSI O STARE IN PIEDI SU QUESTO OGGETTO.
2. Questo prodotto non è un giocattolo. Non permettere ai bambini di giocare con questo articolo o nelle sue vicinanze.
3. Non superare i valori specificati capacità di peso.
4. Utilizzare solo come previsto.
5. Ispezionare prima di ogni utilizzo; non utilizzare se alcune parti sono allentate o danneggiate.

CONSERVARE QUESTO MANUALE

TOOLS





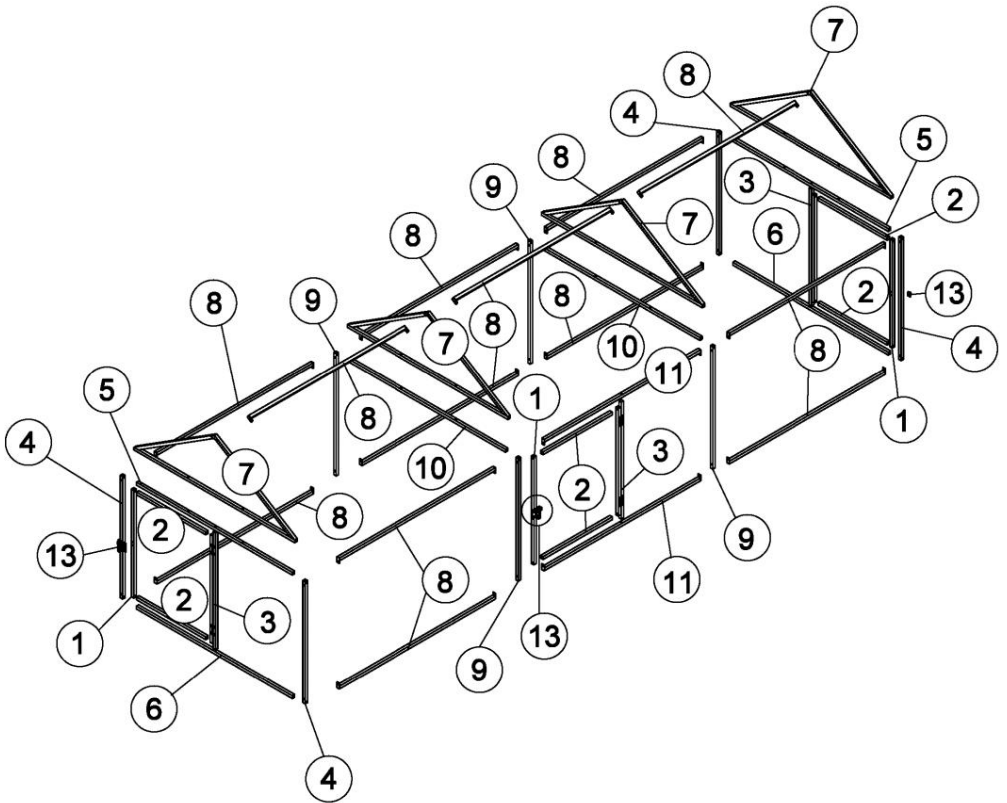

PARTS LIST

Item no.	Reference Image	Qty.	Item no.	Reference Image	Qty.
1		x3	2		x6
3		x3	4		x4
5		x2	6		x2
7		x4	8		x13
9		x4	10		x2
11		x2	13		x3
14		x58	15		x28
16		x1	17		x28
18	 1*12M	x1	19		x12
wire		x1	20		x8
21		x100			

EXPLODED VIEW



ASSEMBLY

PASSO 1										
	1	X3	2	X6	3	X3	17	X12	14	X12





x3

Before

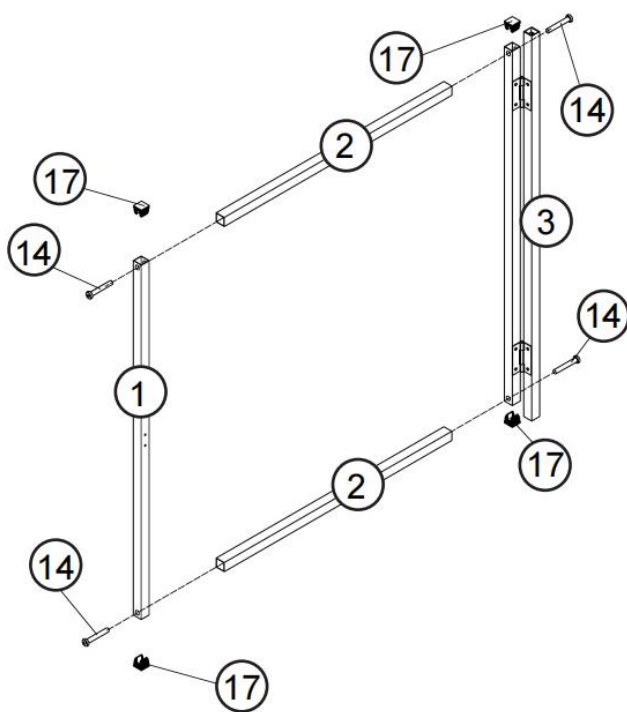



After



PASSO 2										
	4	X4	5	X2	6	X2	17	X4	14	X12

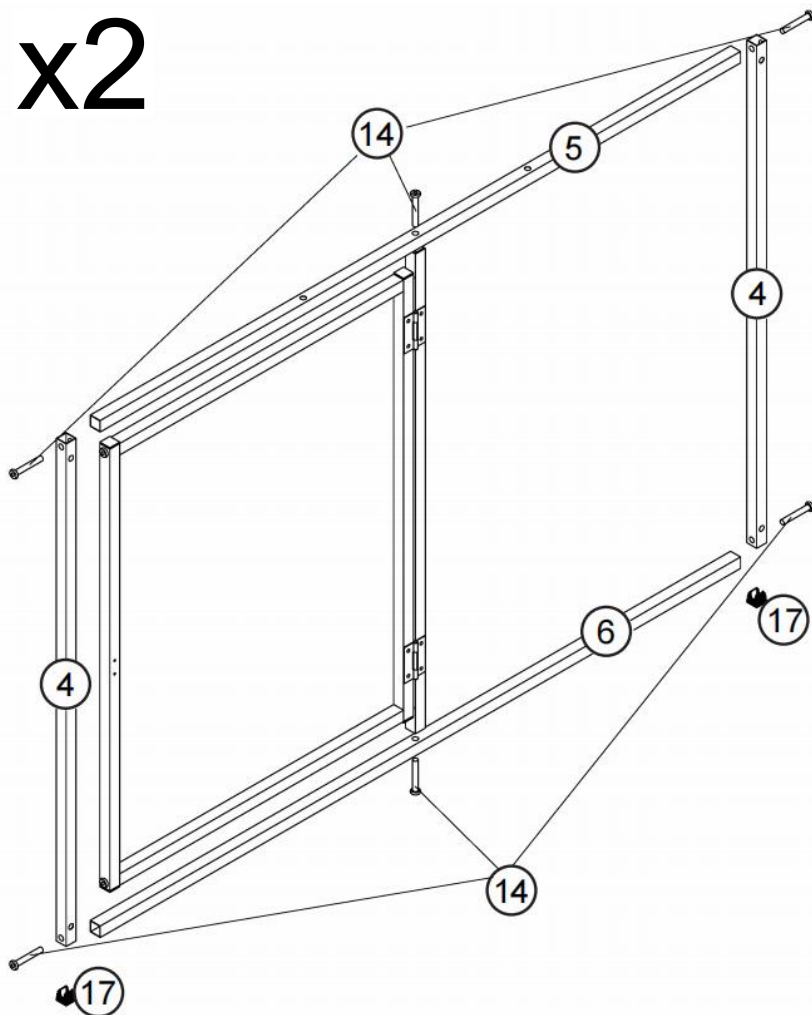

x2



PASSO 3				
	7	X4	17	X8

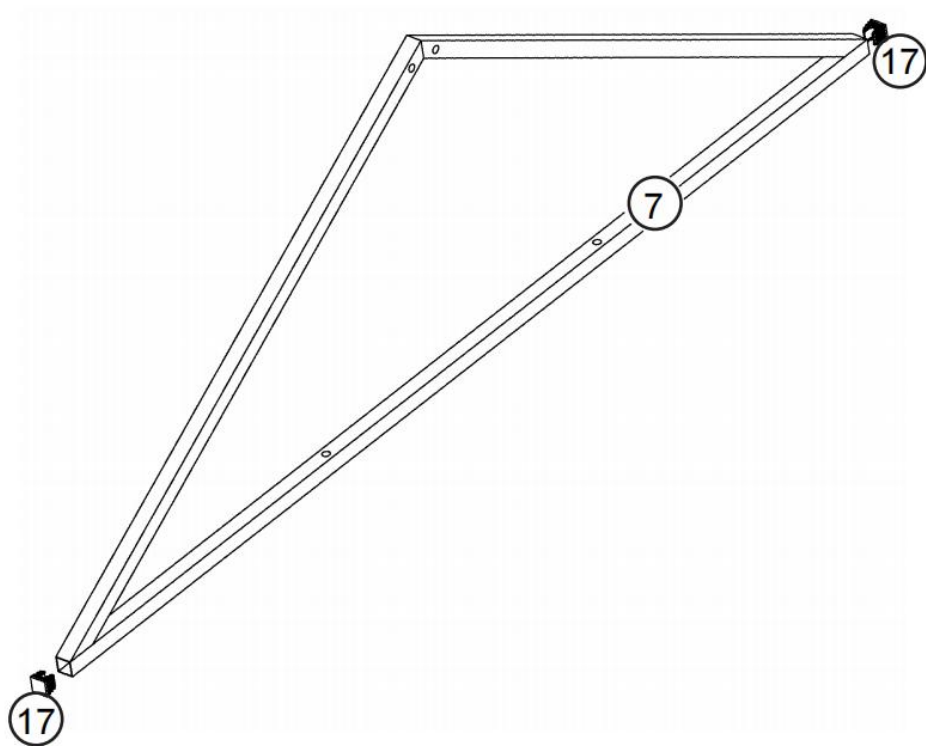

x4





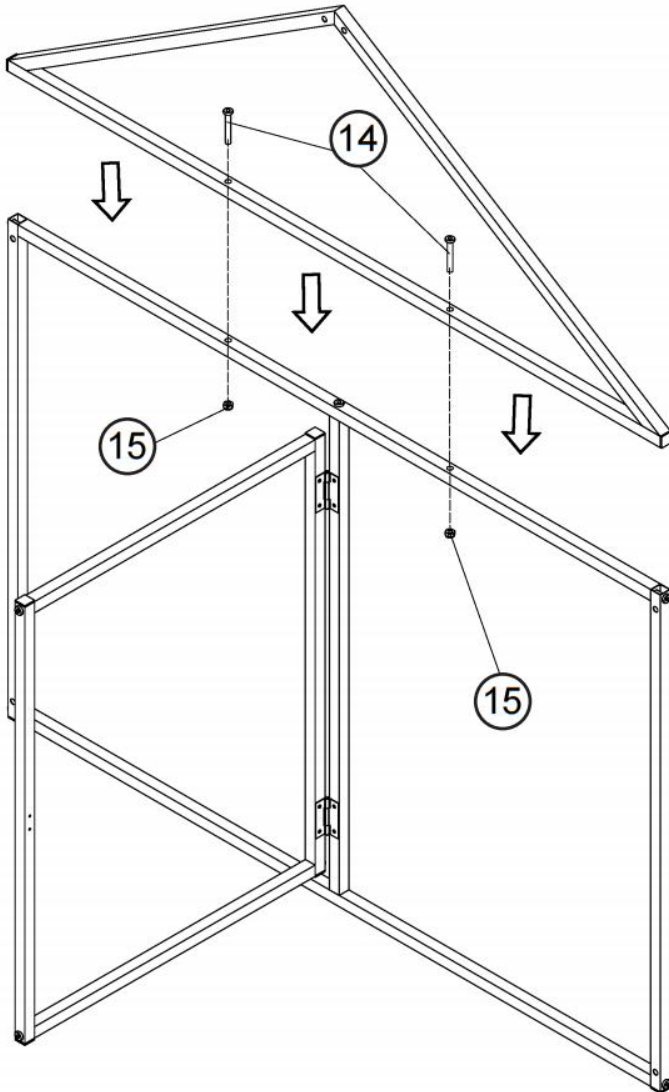

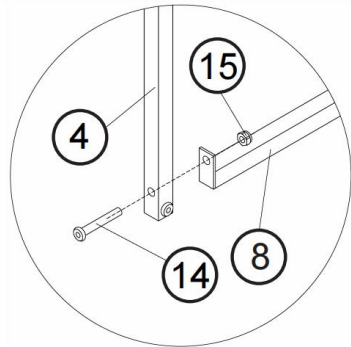
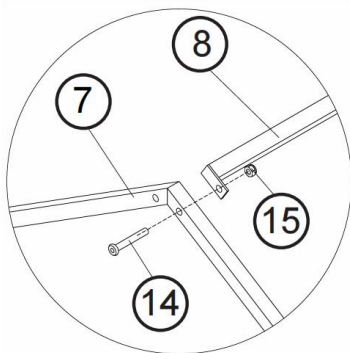
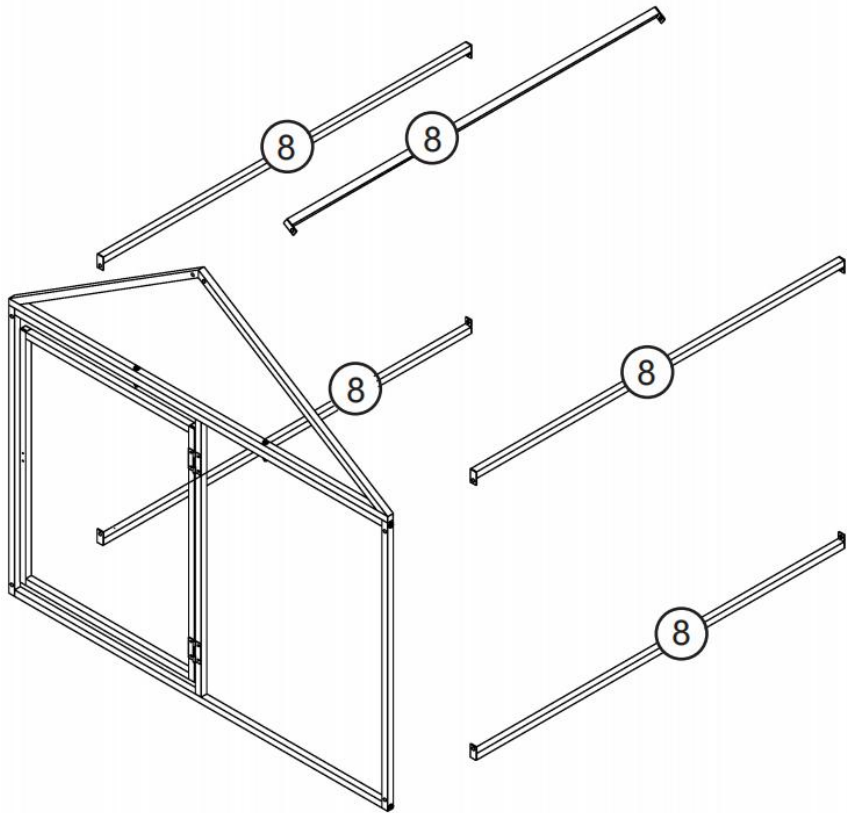

PASSO 4				
	14	X4	15	X4

x2





PASSO 5						
	8	X5	14	X5	15	X5





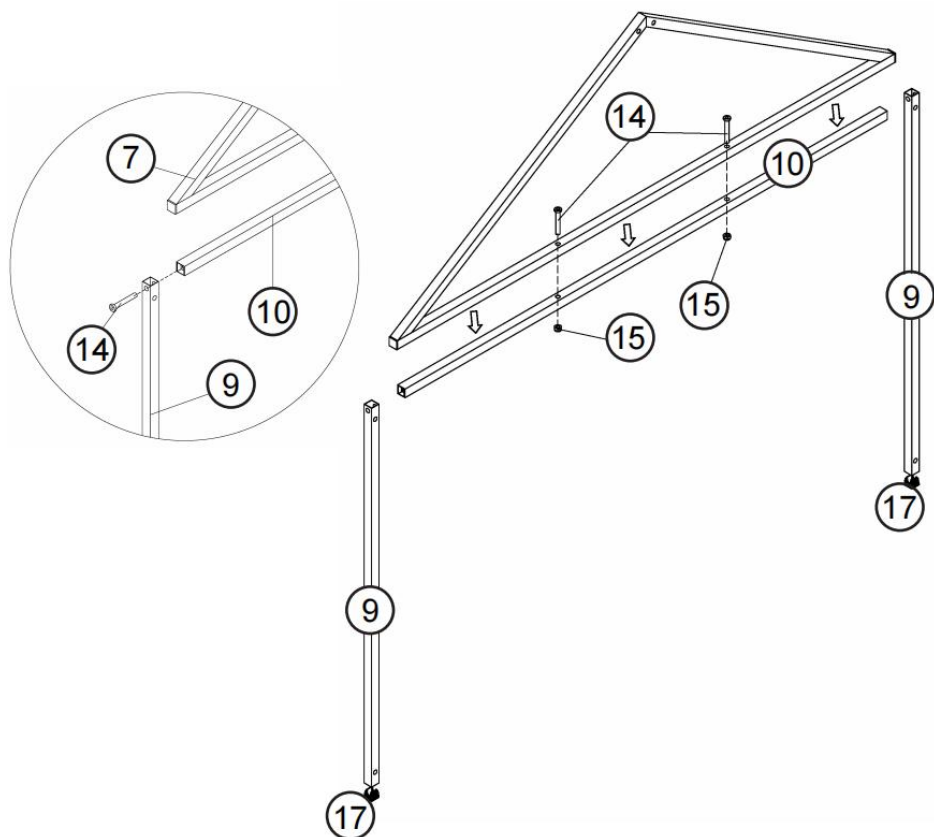

PASSO 6										
	9	X4	10	X2	14	X8	15	X4	14	X4

x2

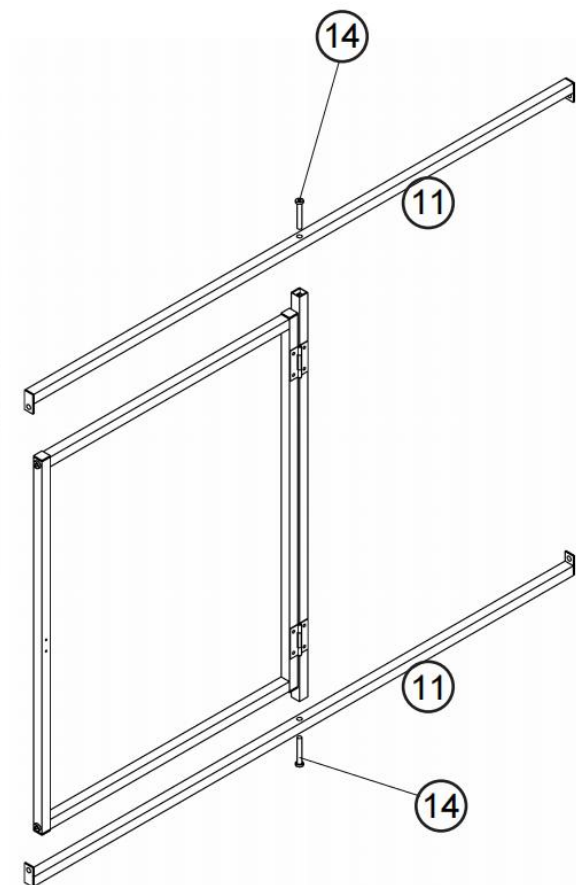
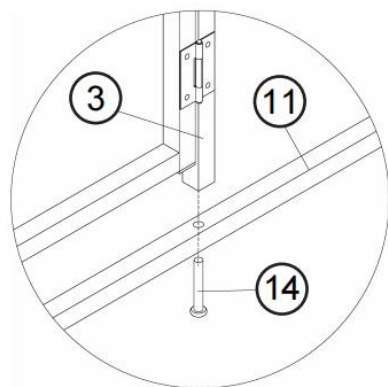



PASSO 7				
	11	X2	14	X2



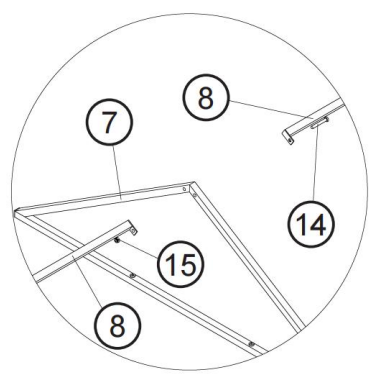
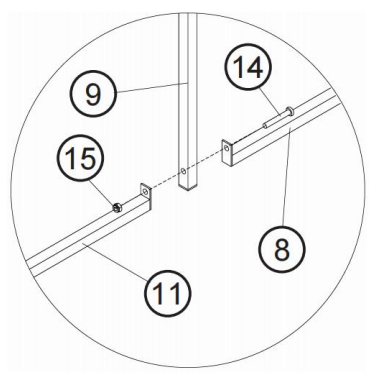
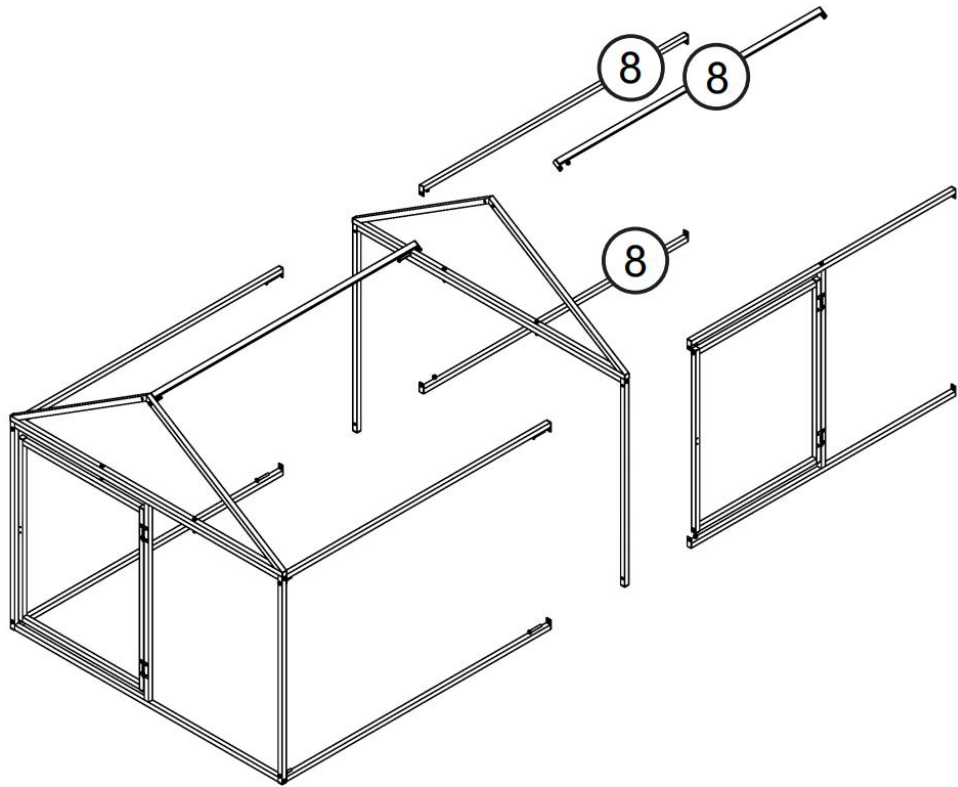

PASSO 8						
	8	X3	14	X5	15	X5

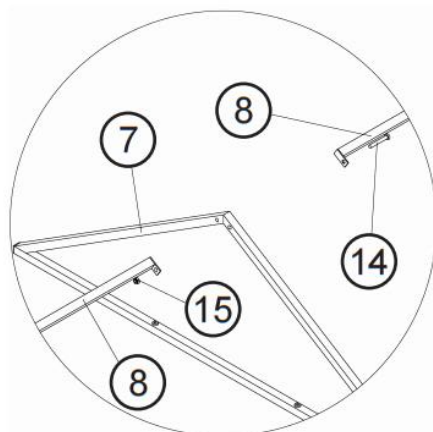
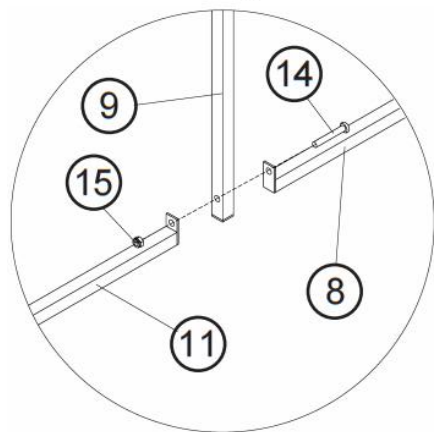
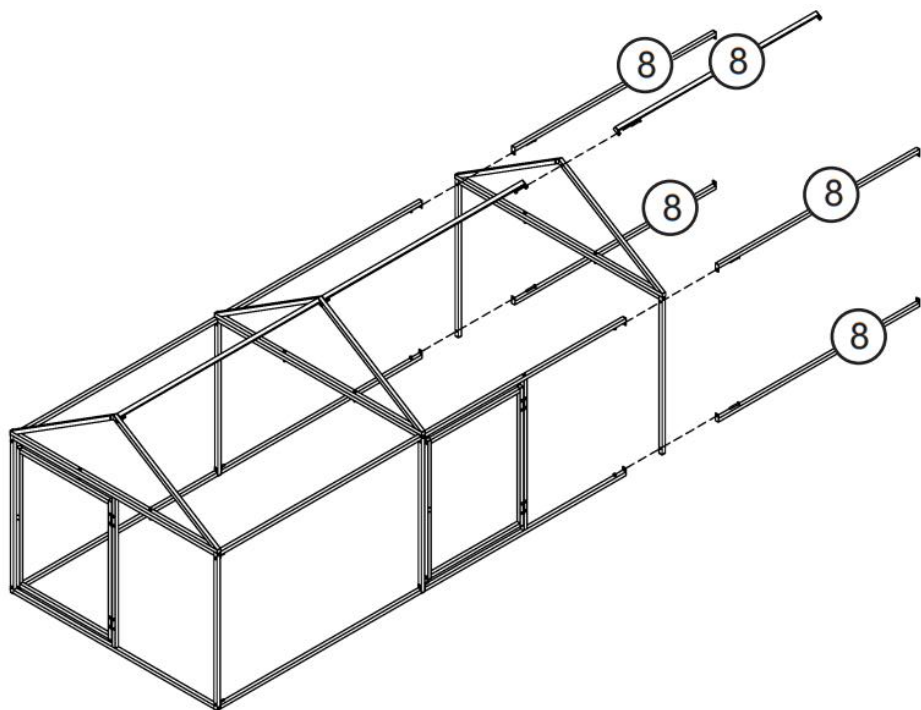

PASSO 9						
	8	X5	14	X5	15	X5



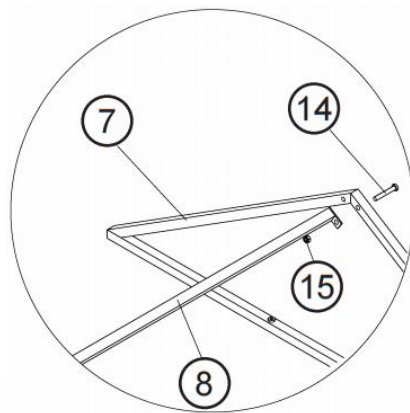
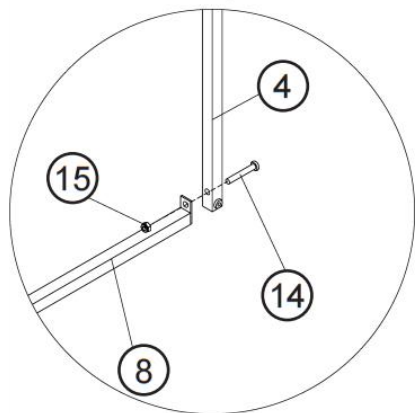
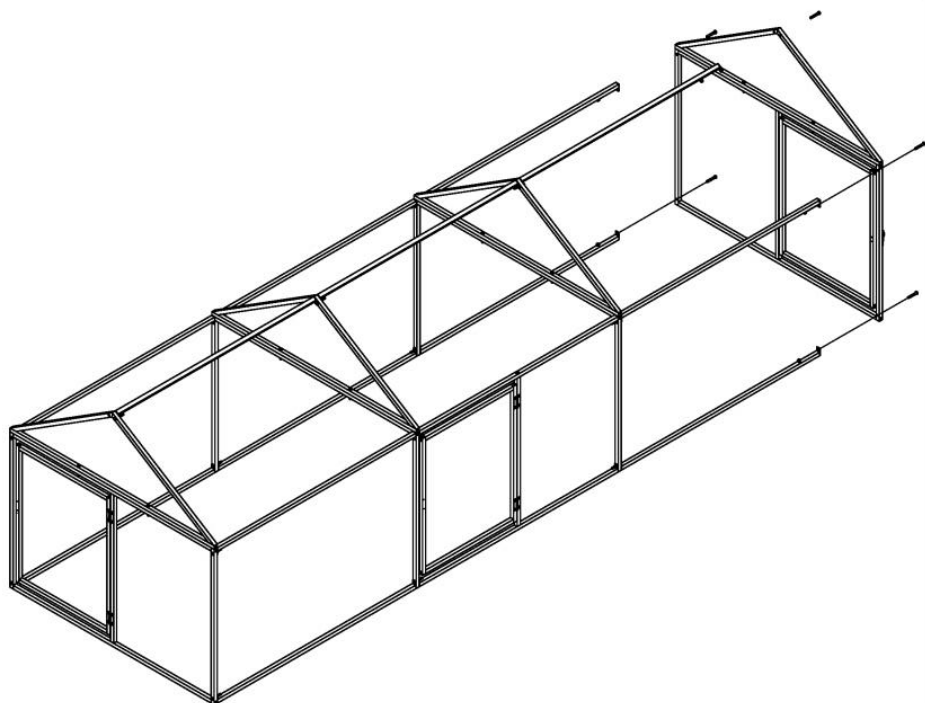

PASSO 10				
	14	X5	15	X5

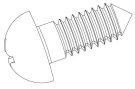

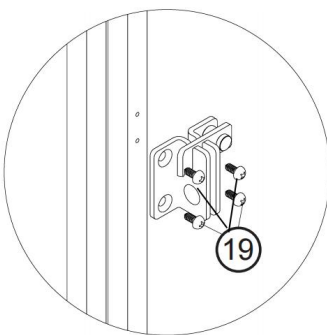
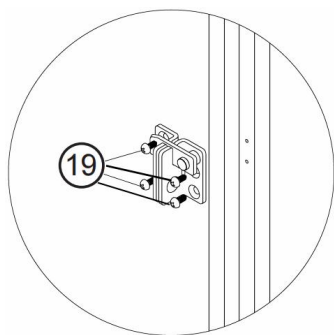
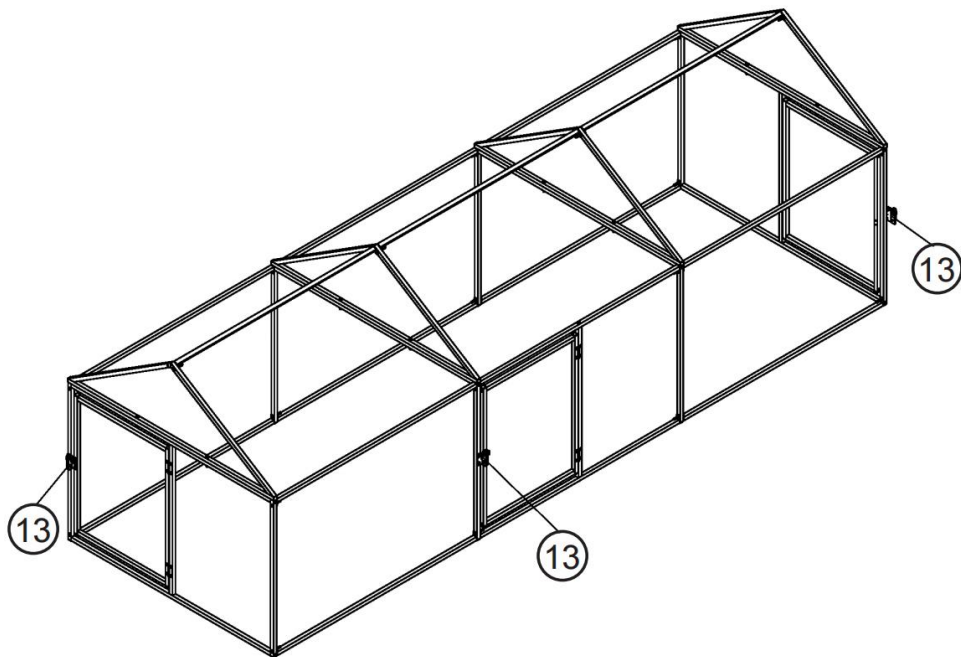
PASSO 11				
	13	X3	19	X12



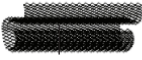

The holes for the left section needs to be drilled by yourself because the door maybe tilt after assembling due to gravity,so adjust the left section's position to make door close properly

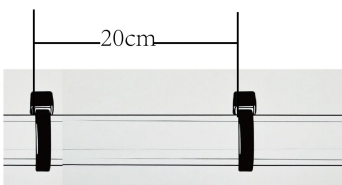
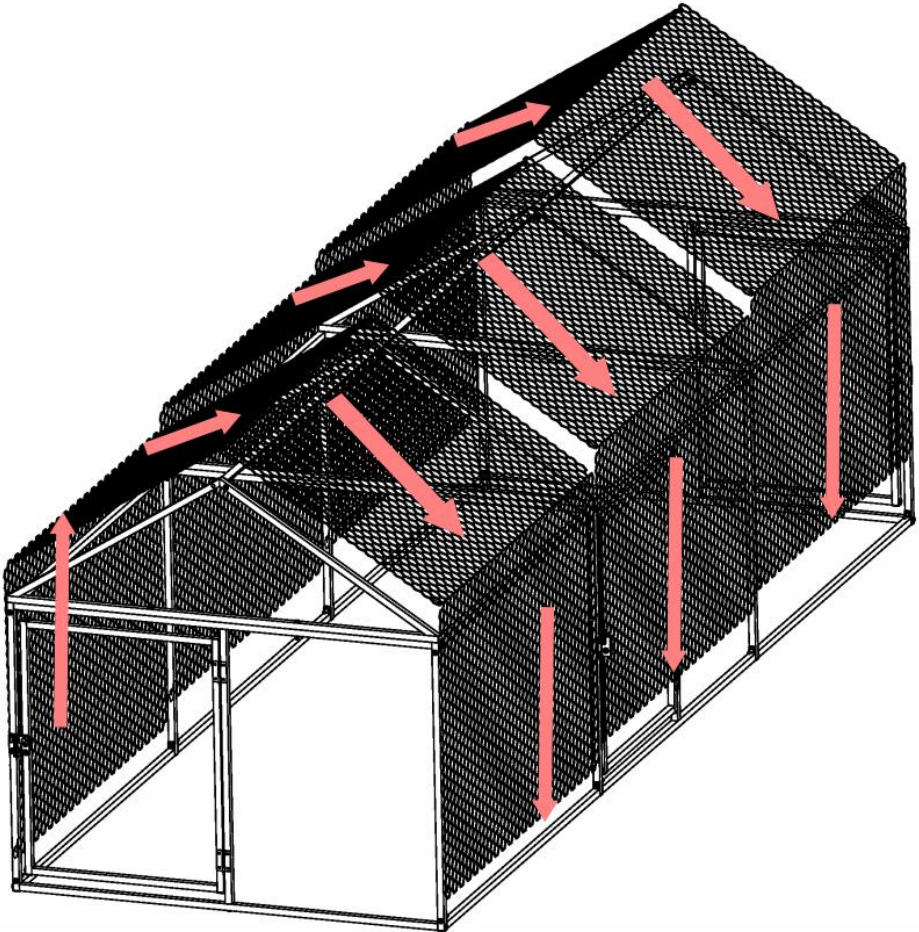
PASSO 12				
	F	X1	N	X60

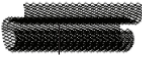

Use zip ties to tie the wire mesh and steel pipes together, with an interval of 20cm between each tie. Tighten the wire mesh by lowering the zip ties

PASSO 13				
	F		N	X40

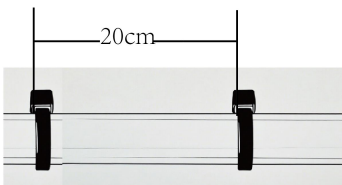
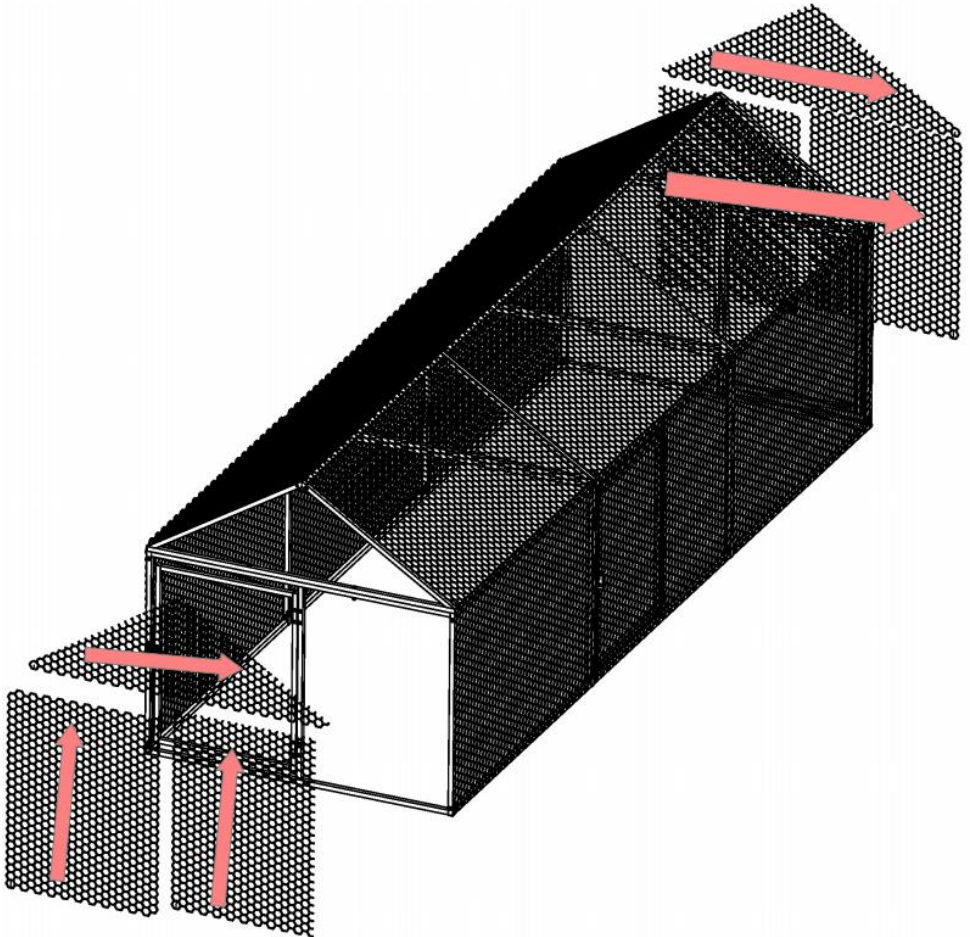

Use zip ties to tie the wire mesh and steel pipes together, with an interval of 20cm between each tie. Tighten the wire mesh by lowering the zip ties

PASSO 14



16

X1

Rope on 16

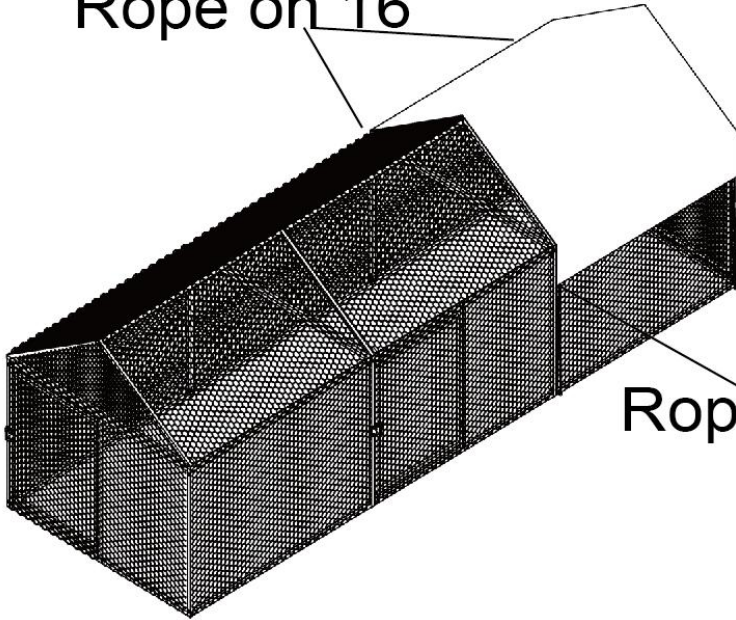

Rope on 16

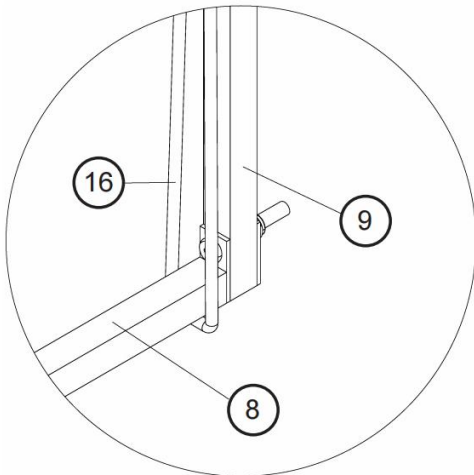

PASSO 15		
	20	X8

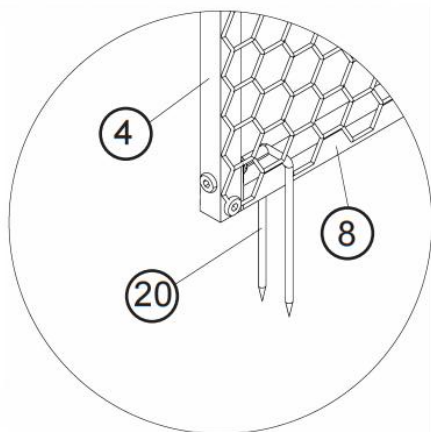
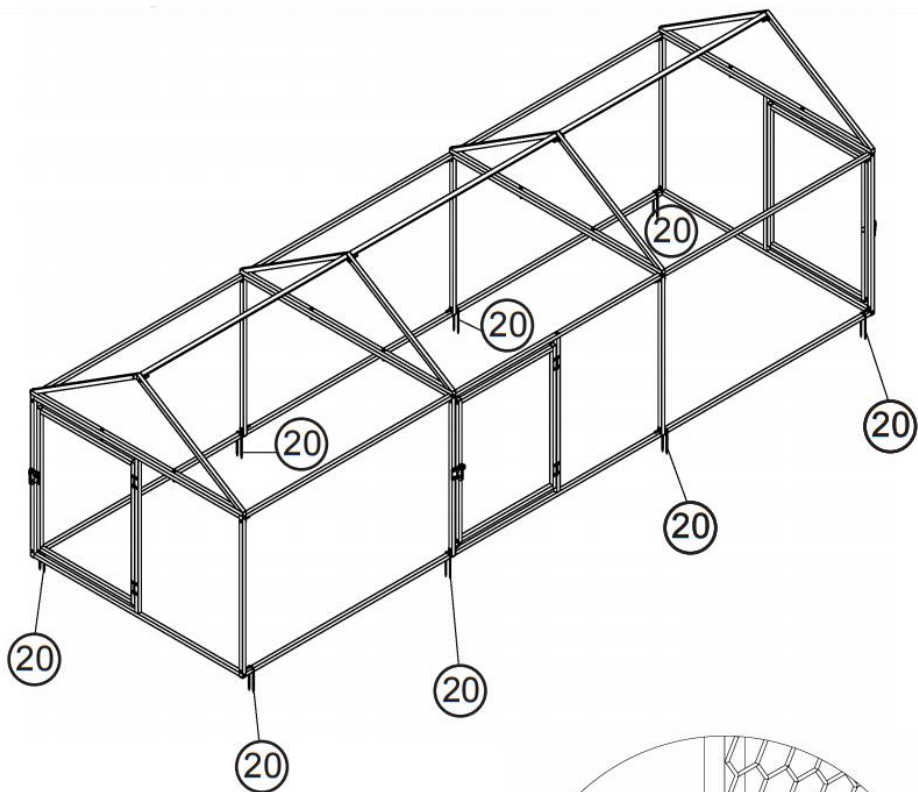

PASSO 16		
	Filo	X1

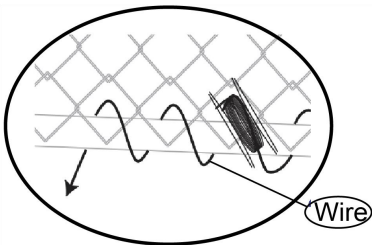
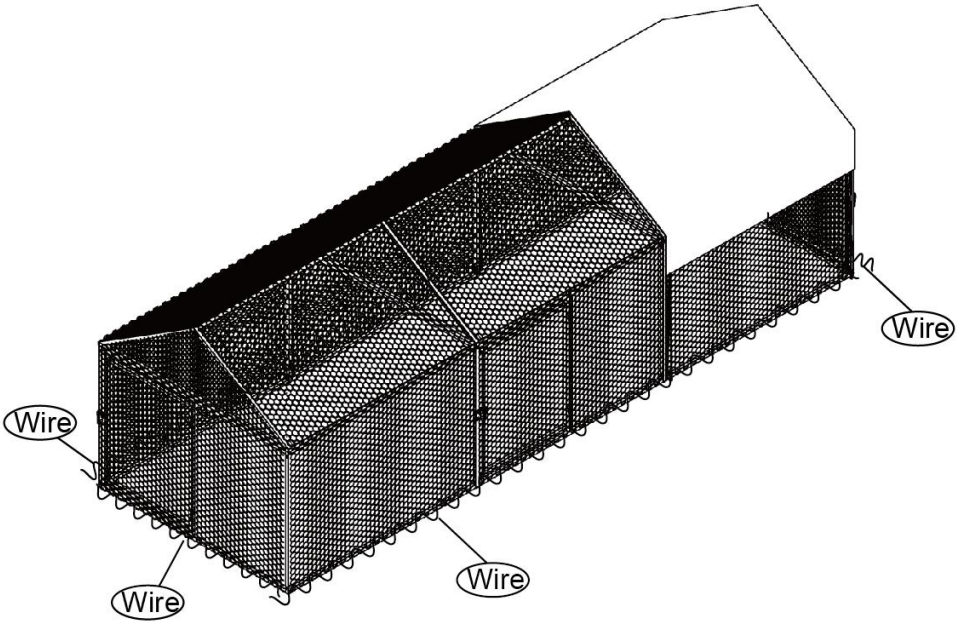

Note

Spiral wrap the wire at the bottom to reinforce the wire mesh and steel pipe, with a distance of 15cm between each circle. The single wire should not be wrapped more than 2 meters, and it needs to be tightened during wrapping. The knot should be firm and not loosened

PARAMETRO DEL PRODOTTO

Modello	CRCFG0103
Colore	Nero + Bianco
Dimensioni del prodotto	3 000×1000× 1 000mm
Materiale	Tessuto Q235+PE

AVVISO

Pianificazione e selezione del sito

Scegliere aree con terreno elevato e buon drenaggio per evitare che le parti metalliche arrugginiscono a causa dell'accumulo di acqua durante la stagione delle piogge; livellare il sito in anticipo, rimuovere pietre, erbacce e altri detriti e, se necessario, gettare fondamenta in cemento (soprattutto per i grandi pollai in metallo) per migliorare la stabilità.

Ispezione dei materiali e preparazione degli utensili

Controllare che la lamiera, il telaio, le viti e gli altri accessori siano intatti, che non vi siano deformazioni, ruggine o danni e preparare utensili professionali come trapani elettrici, chiavi inglesi, metri a nastro, utensili da taglio (se necessario per regolare le dimensioni della lamiera), ecc.

Ispezione completa dopo l'installazione

Verificare la stabilità della struttura complessiva, l'allentamento o la deformazione delle assi, l'uniformità degli interruttori di porte e finestre e il corretto funzionamento delle aperture di ventilazione. Pulire regolarmente il pollaio da feci e detriti per evitare l'accumulo di sporco dovuto alla corrosione delle parti metalliche. Verificare il serraggio delle viti e l'integrità dei rivestimenti antiruggine una volta al trimestre, verificare che le reti non siano allentate e intervenire tempestivamente per prolungare la durata del pollaio.

Produttore: Shanghaimuxinmuyeyouxiangongsi

Indirizzo: Shuangchenglu 803nong11hao1602A-1609shi, baoshanqu, Shanghai 200000 CN.

Importato in AUS: SIHAO PTY LTD. 1 ROKEVA STREETEASTWOOD
Nuovo Galles del Sud 2122 Australia

Importato negli USA: Sanven Technology Ltd. Suite 250, 9166 Anaheim
Luogo, Rancho Cucamonga, CA 91730

UK	REP
-----------	------------

YH CONSULTING LIMITED. C/O YH Consulting
Limited Office 147, Centurion House, London
Road, Staines-upon-Thames, Surrey, TW18 4AX

EC	REP
-----------	------------

E-CrossStu GmbH
Mainzer Landstr.69,
60329 Frankfurt am Main.

