

VEVOR

Affordable. Reliable. Home Improvement.

FABRIC LOVESEAT RECLINER

MODEL:A1503-2DLR

Fabric loveseat recliner installation instruction video:

d2qc09rl1gfuof.cloudfront.net/product/DDBYSRSFDDKDAD7LT001/fabric+Loveseat+Recliner+Installation+Instruction+Video.mp4



VEVOR



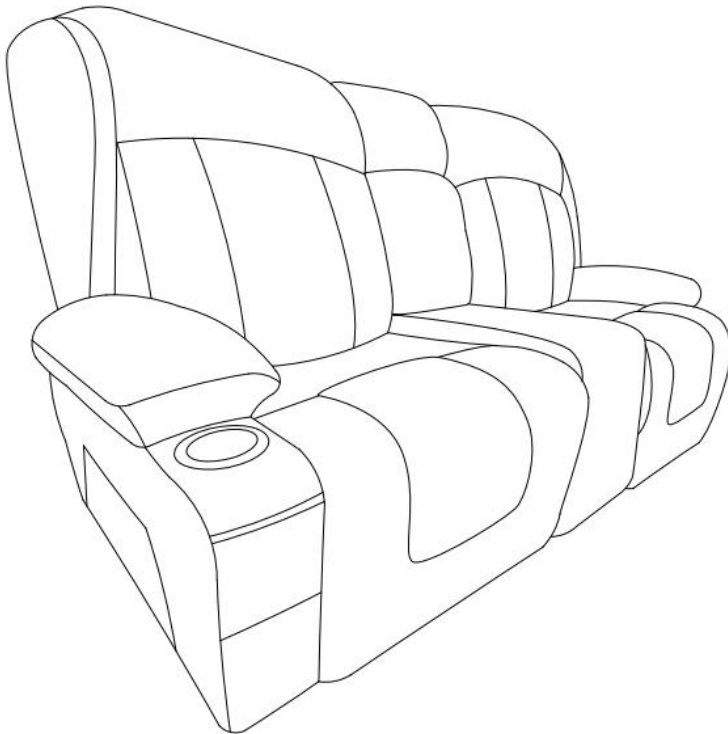

Affordable. Reliable. Home Improvement.

Fabric Loveseat
Recliner

MODEL:A1503-2DLR



This is the original instruction, please read all manual instructions carefully before operating. VEVOR reserves a clear interpretation of our user manual. The appearance of the product shall be subject to the product you received. Please forgive us that we won't inform you again if there are any technology or software updates on our product.

	<p>Warning-To reduce the risk of injury, user must read instructions manual carefully.</p>
	<p>Compliance is a CE security certification.</p>
	<p>CORRECT DISPOSAL</p> <p>This product is subject to the provision of European Directive 2012/19/EC. The symbol showing a wheeled bin crossed through indicates that the product requires separate refuse collection in the European Union. This applies to the product and all accessories marked with this symbol. Products marked as such may not be discarded with normal domestic waste, but must be taken to a collection point for recycling electrical and electronic devices.</p>
	<p>Warning- For Indoor Use Only</p>
	<p>FCC Information:</p> <p>CAUTION: Changes or modifications not expressly approved by the party responsible for compliance could void the user's authority to operate the equipment!</p> <p>This device complies with Part 15 of the FCC Rules. Operation is subject to the following two conditions:</p> <ol style="list-style-type: none"> 1) This product may cause harmful interference. 2) This product must accept any interference received, including interference that may cause undesired operation. <p>WARNING: Changes or modifications to this product not expressly approved by the party responsible for compliance could void the user's authority to operate the product.</p> <p>Note: This product has been tested and found to comply with the limits for a Class B digital device pursuant to Part 15 of the FCC Rules, These limits are designed to provide reasonable protection against harmful interference in a residential installation.</p> <p>This product generates, uses and can radiate radio frequency energy, and if not installed and used in accordance with the</p>

instructions, may cause harmful interference to radio communications. However, there is no guarantee that interference will not occur in a particular installation. If this product does cause harmful interference to radio or television reception, which can be determined by turning the product off and on, the user is encouraged to try to correct the interference by one or more of the following measures.

- Reorient or relocate the receiving antenna.
- Increase the distance between the product and receiver.
- Connect the product to an outlet on a circuit different from that to which the receiver is connected.
- Consult the dealer or an experienced radio/TV technician for assistance.

SAFETY INSTRUCTIONS

WARNING:

Read this material before using this product. Failure to do so may result in serious injury.

Assembly precautions

1. Assemble only according to these instructions. Improper assembly may create hazards.
2. Wear ANSI-approved safety goggles and heavy-duty work gloves during assembly.
3. Keep the assembly area clean and well-lit.
4. Keep bystanders out of the area during assembly.
5. Do not assemble if tired or when under the influence of alcohol, drugs or medication.
6. Also, while it is possible to assemble the chair on your own, having a second person to help you makes it even easier.
7. The product capabilities apply to properly and completely assembled products only.
8. Assemble on a flat, level, hard and smooth surface capable of safely supporting the Fabric Loveseat Recliner.
9. Before you begin, please check if there are any missing parts from the package. Should there be any issues, please don't hesitate to drop us an email and we'll help you out ASAP.
10. For additional information regarding the parts listed in the following pages, please refer to the Assembly Diagram of this manual. Unwrap and separate all parts in a clean work area.

Use precautions

1. Use as intended only.
2. Inspect before every use; do not use if parts are loose or damaged.

SAVE THIS MANUAL

PARTS LIST

 Seat cushion (A)*1	 Seat cushion (A)*1	L  Back (B)*1	R  Back (B)*1
 Middle Back (B)*1	L  Seat frame (C)*1	R  Seat frame (C)*1	 Middle Seat (C)*1
 F (L) Armrest bag (F)*1	 F (R) Armrest bag (F)*1	 Back ear L*1	 Back ear R*1
 Massage remote control board (G)*2	 Motor power supply (I)*2	 Power line (X)*2	 Glove *2
 Cup holder *2	 Screw (N)*8	 Spanner (O)*1	 Connector *4
 Screw (S)*4	 Spacer (T)*4		
<div style="display: flex; align-items: center;"> <div style="margin-right: 20px;"> <p>Under the frame</p>  </div> <div style="margin-right: 20px;">  </div> <div style="text-align: right;">   </div> </div>			

ASSEMBLY STEP

STEP 1: Open the compression bag and remove the soft bag.

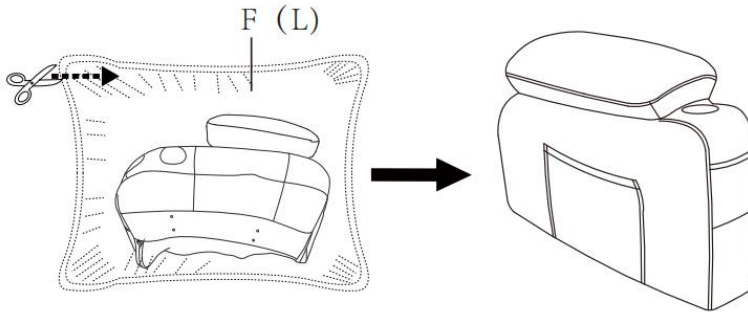

STEP 2: Repeat Step 1.

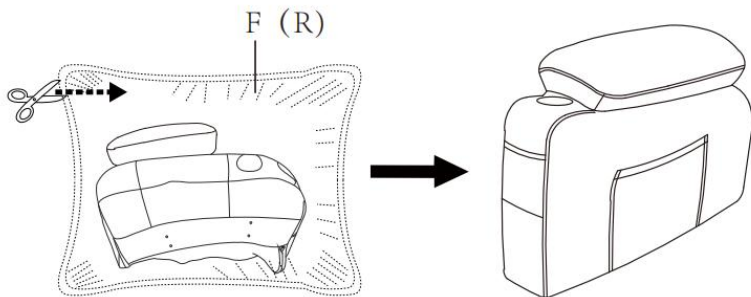

STEP 3: Fix the connector to the inside of the armrest with M6x16mm screws, paying attention to the direction of fixing the connector.

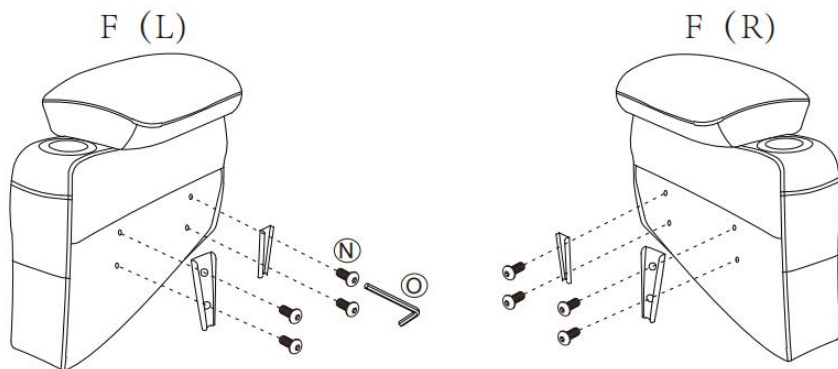

STEP 4: Fix the screws on both sides of the middle seat.

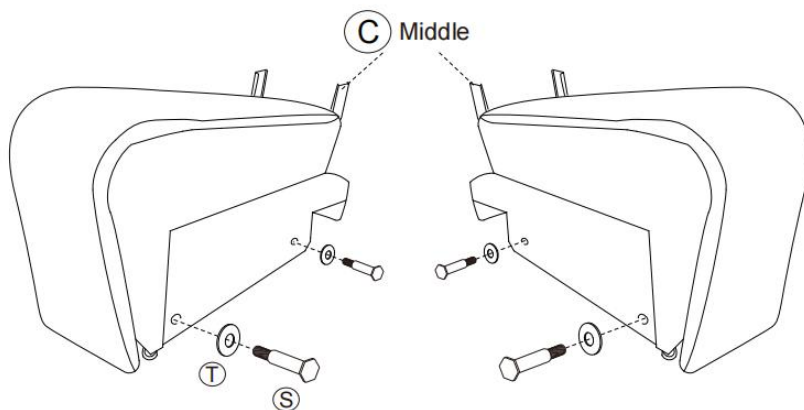

STEP 5:Place the cup holder into the groove.

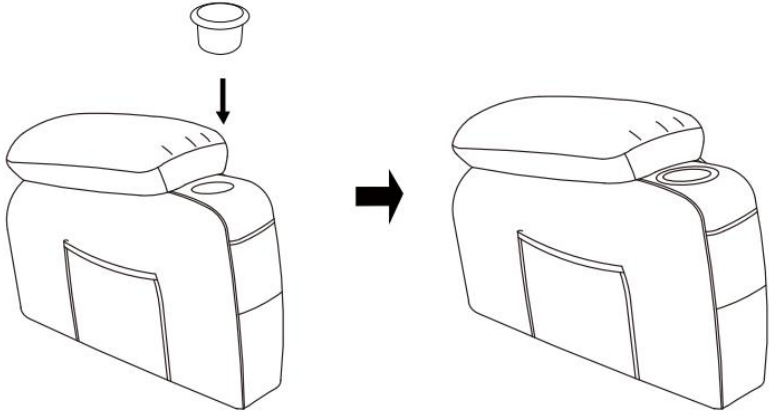

STEP 6:Insert arms so that they can fit into the seat, you will hear a “click” when they are engaged.

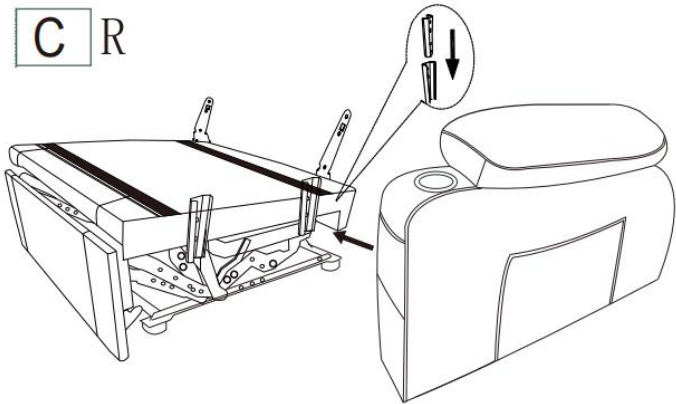

STEP7: Repeat Step 6

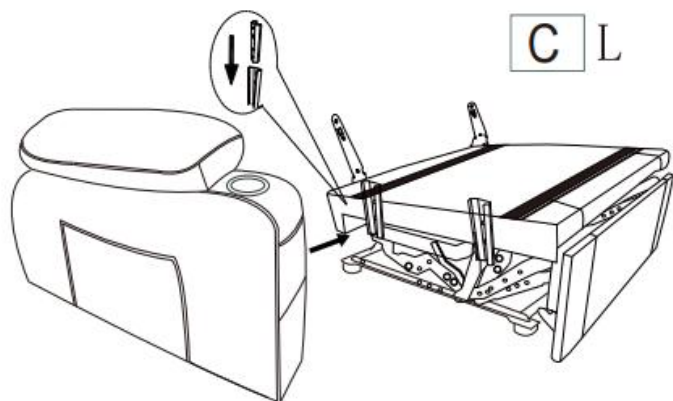

STEP8: Open seat bag A, stick the Velcro on the footboard, and stick the Velcro on the seat bag.

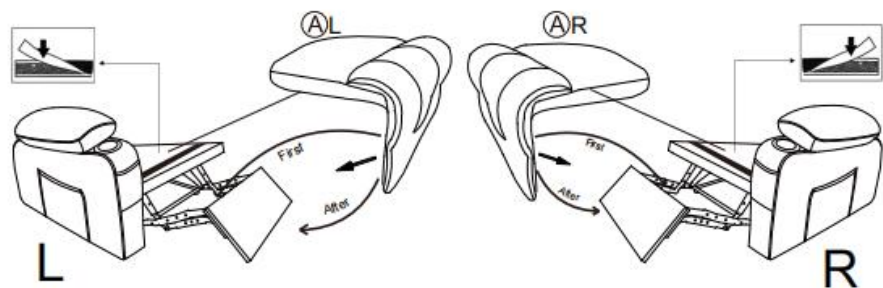

Note: First, power on, turn on the footrest, and then install the seat cushion

STEP 9: Plug the back pad into the seat frame, then connect the massager lines: white with white, red with red, black with the power lines, connect the massage line with the handcontroller.

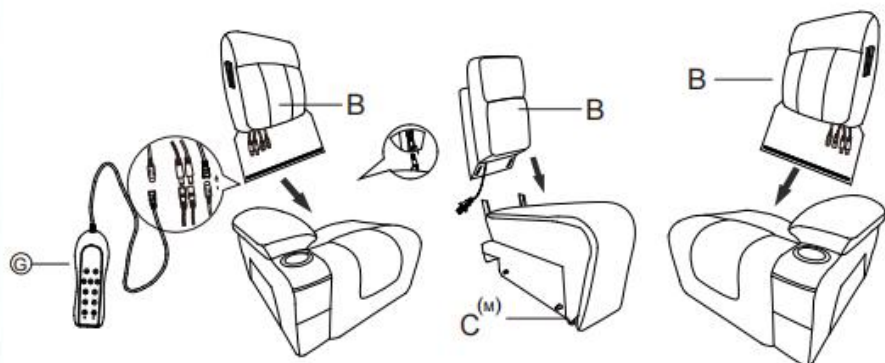

STEP 10: Install the back ears on both sides of the backrest.

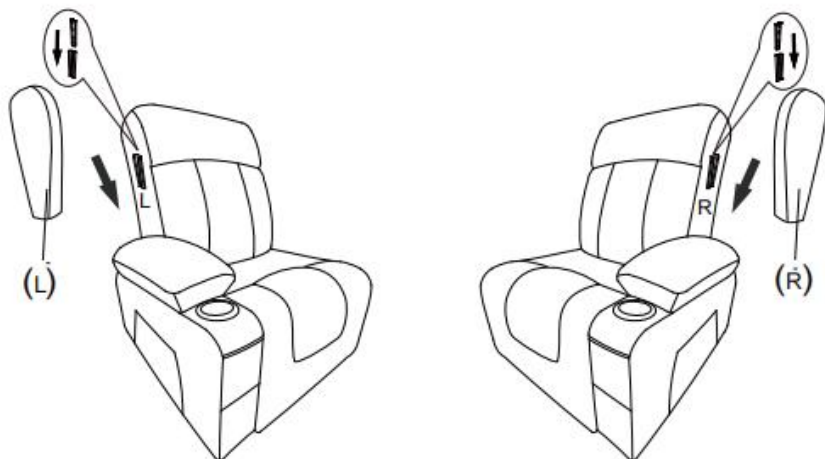

STEP 11 :Hang the middle position on the pendant slots on the left and right positions, and the three chairs can be connected together.

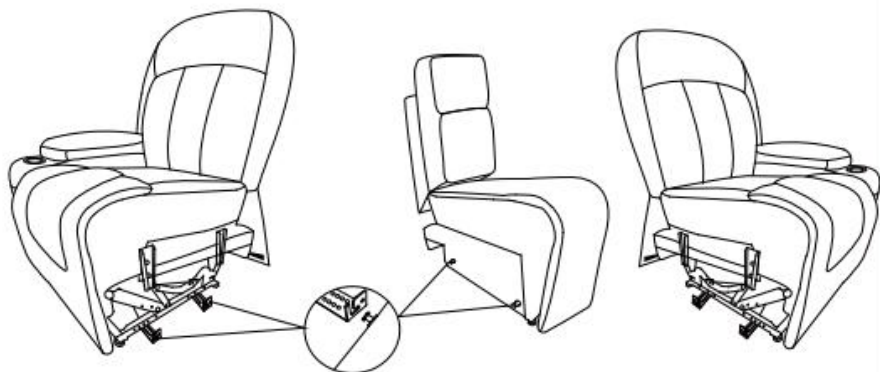

STEP 12 :Connect the power cord (X) to the power adapter (I),finally,stick up the Velcro below.Connect the power cord to the middle seat.

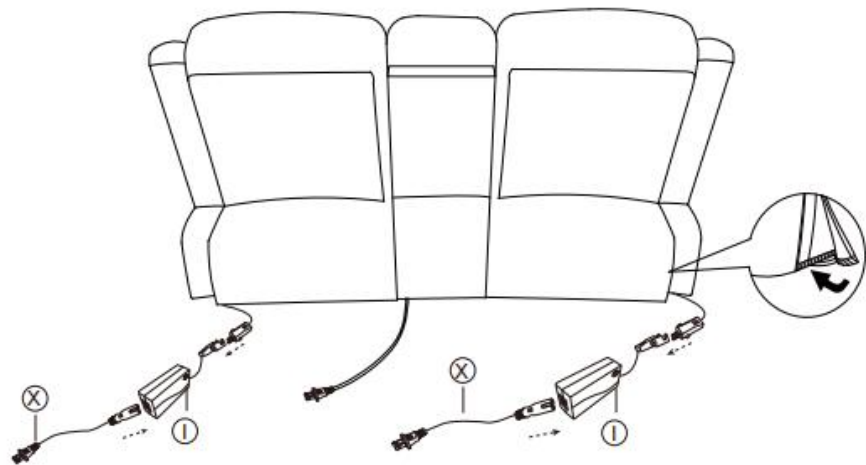

Congratulations! You've assembled
Your Sofa!

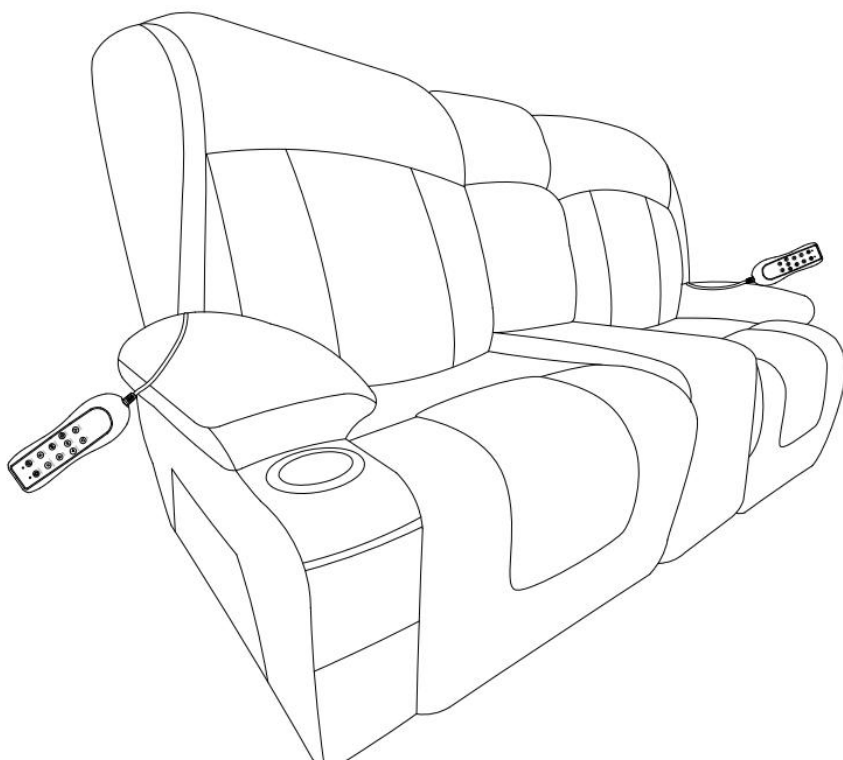

Note:

Since the backrest is packed in compression, after the product is installed, you need to tap and adjust the backrest which can help restore fullness. After two days, you will get a Overstuffed Recliners as picture shows.

OPERATING INSTRUCTION

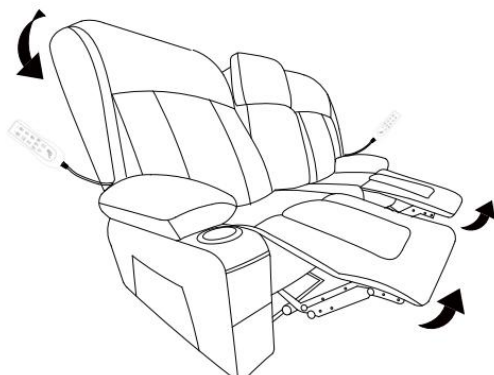

Press the switch to open the sofa

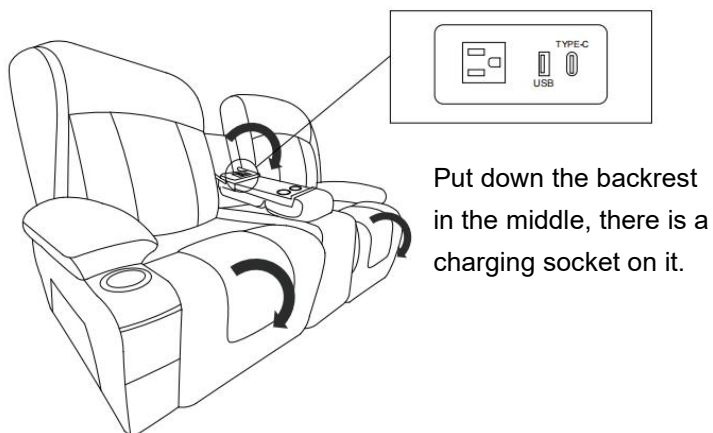

Press the switch to lift the sofa

FUNCTION OF THE REMOTE CONTROL

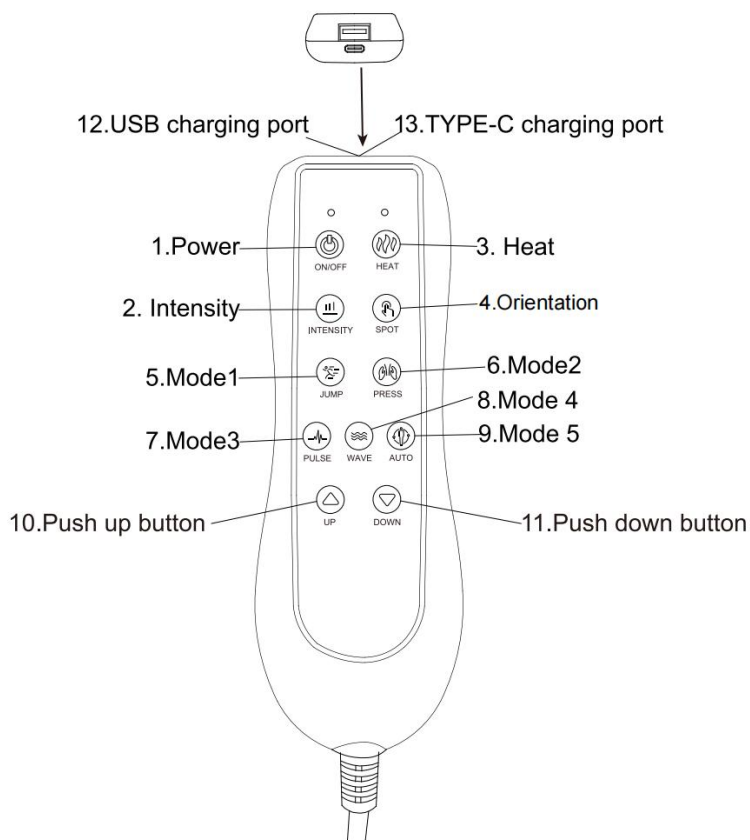

Product features

1. 4 Position, 8 Vibration motor
2. 5 motor vibration modes
3. Add hot spots to one part
4. The default shutdown duration is 15 minutes
5. 1 way electric push rod
6. USB/TYPE-C charging function

Function details

1. Switch on and off (Boot vibration full on (default strong/automatic mode))

2. Switch point by vibration intensity

3. Click heating switch circulation

4. Vibration positioning key

By default, the vibration is fully on when the machine is started

Sequence switch motor vibration in individual parts (back vibration → waist vibration → Leg vibration → Neck vibration → full open) cycle

5. Mode 1 (Skip mode)

6. Mode 2 (Press vibration mode)

7. Mode 3 (Pulse vibration mode)

8. Mode 4 (Wave vibration mode)

9. Mode 5 (Conventional vibration mode)

10. Long press the push rod upward

11. Long press the putter down

12. USB charging port

13. TYPE-C charging port

WARNINGS

- Sit down in the chair gently. To avoid tipping over, do not throw yourself into the chair. Move the chair into the reclining position slowly, making sure that no children or pets are in close proximity. Do not allow children to play on or around the chair, particularly when it is in an open position.
- Close the recliner completely before getting out of it.
- Never sit on the footrest when it is open, even if it is a child.
- To eliminate the risk of tipping over, do not sit on the arms or footrest of the chair.
- This chair is designed to be used by 1 adult at a time.
- Please forbid people with the following ailments from using this sofa: Those people with severe symptoms of heart disease, high blood pressure, cerebral thrombosis and others who are sensitive to heat or completely insensitive to heat, those with brittle bones or have issues with waist support pregnant women, children and others where it has been determined they are not suitable to use this product under the guidance of doctors.
- To fully recline the sofa, ensure the sofa well, you need to put the sofa at least 19 inches away from the wall or any other obstacle.
- Product cannot touch water, fire, etc. Product can also not come in contact with sharp objects (knives, nails, etc.)

MAINTENANCE MANUAL INSTRUCTIONS

- To avoid dropping, you should carry the sofa carefully.
- If you find dirt and or stains on the chair, spray the sofa with a sofa specific cleaner then use a sponge or cloth to wipe the dirt away. Do not use water, soapy water or cleaner with waxed wooden areas. Take care to wipe the sofa carefully and gently.
- Do not put the sofa in an area with direct sunlight and do not put the sofa directly in front of an air conditioner, this will fade the upholstery and make it brittle.

HOW TO DISASSEMBLE

Please find a strong tool to prod the small piece of metal grooves, then the backrest will be pulled out. The tool is not included.

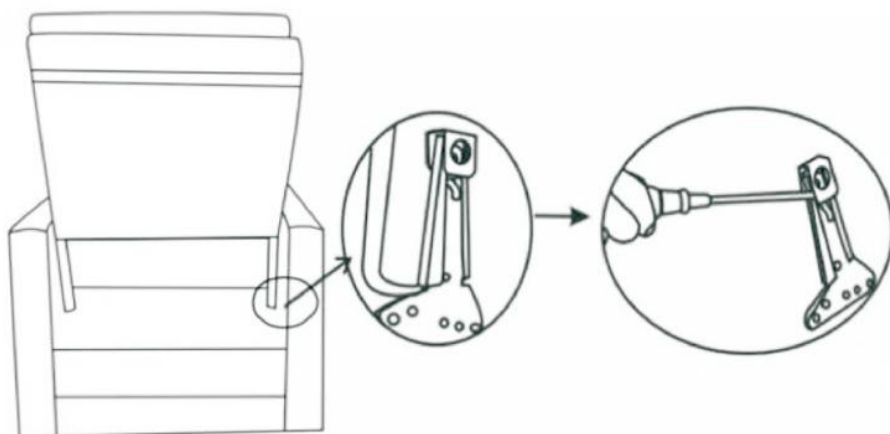

PRODUCT PARAMETER

Model	A1503-2DLR
Rating(s)	100V-240V 50/60Hz 1.5A
Main Color	Brown
Single-seat load-bearing capacity	330 lbs
Product Size(D*W*H)	965*1830*1080mm
Net Weight	75kg

* Products such as specifications, appearance, and design are subject to modification without prior notice.

Manufacturer: Shanghaimuxinmuyeyouxiangongsi

Address: Shuangchenglu 803nong11hao1602A-1609shi, baoshanqu, shanghai 200000 CN.

Imported to AUS: SIHAO PTY LTD. 1 ROKEVA STREETEASTWOOD NSW 2122 Australia

Imported to USA: Sanven Technology Ltd. Suite 250, 9166 Anaheim Place, Rancho Cucamonga, CA 91730

EC	REP
-----------	------------

E-CrossStu GmbH
Mainzer Landstr.69, 60329 Frankfurt am Main.

UK	REP
-----------	------------

YH CONSULTING LIMITED.
C/O YH Consulting Limited Office 147, Centurion House, London Road, Staines-upon-Thames, Surrey, TW18 4AX



VEVOR

Affordable. Reliable. Home Improvement.

FAUTEUIL INCLINABLE EN TISSU

MODÈLE : A1503-2DLR

Vidéo d'instructions d'installation du fauteuil inclinable en tissu :

d2qc09r11gfuof.cloudfront.net/product/DDBYSRSFDDKDAD7LT001/fabric+Loveseat+Recliner+Installation+Instructions+Vidéo.mp4



VEVOR



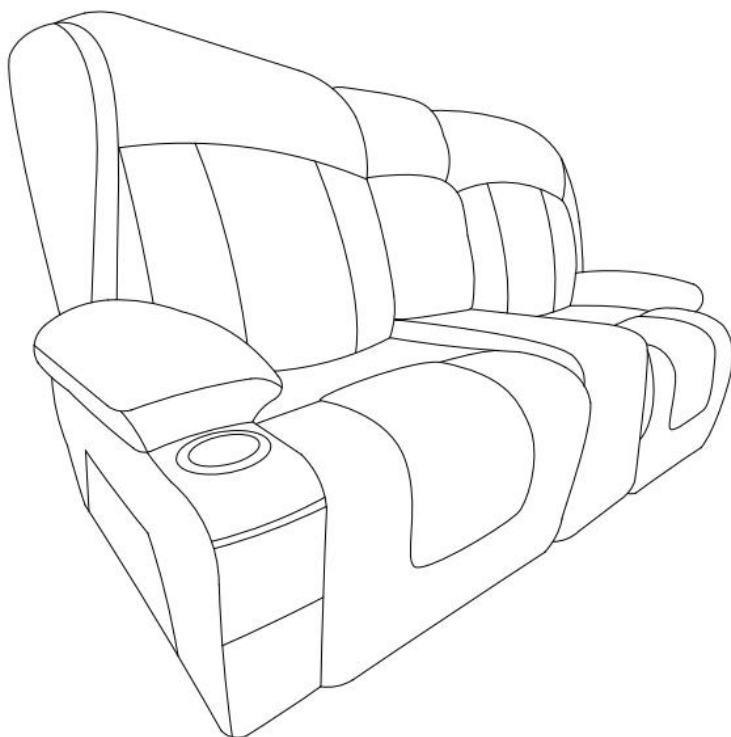

Affordable. Reliable. Home Improvement.

Fabric Loveseat
Recliner

MODÈLE : A1503-2DLR



Ceci est le mode d'emploi d'origine. Veuillez lire attentivement l'intégralité du manuel avant utilisation. VEVOR se réserve le droit d'interpréter clairement ce manuel d'utilisation. L'apparence du produit dépend du produit que vous avez reçu. Veuillez nous excuser pour les éventuelles mises à jour technologiques ou logicielles.

	<p>Avertissement - Pour réduire le risque de blessure, l'utilisateur doit lire attentivement le manuel d'instructions.</p>
	<p>La conformité est une certification de sécurité CE .</p>
	<p>ÉLIMINATION CORRECTE</p> <p>Ce produit est soumis aux dispositions de la directive européenne 2012/19/CE. Le symbole représentant une poubelle barrée indique que le produit doit faire l'objet d'une collecte sélective dans l'Union européenne. Ceci s'applique au produit et à tous les accessoires marqués de ce symbole. Les produits ainsi marqués ne doivent pas être jetés avec les ordures ménagères, mais doivent être déposés dans un point de collecte pour le recyclage des appareils électriques et électroniques .</p>
	<p>Avertissement - Pour usage intérieur uniquement</p>
	<p>Informations FCC :</p> <p>ATTENTION : Les changements ou modifications non expressément approuvés par la partie responsable de la conformité pourraient annuler le droit de l'utilisateur à utiliser l'équipement !</p> <p>Cet appareil est conforme à la partie 15 de la réglementation FCC. Son utilisation est soumise aux deux conditions suivantes :</p> <ol style="list-style-type: none"> 1) Ce produit peut provoquer des interférences nuisibles. 2) Ce produit doit accepter toute interférence reçue, y compris celles qui peuvent provoquer un fonctionnement indésirable. <p>AVERTISSEMENT : Les changements ou modifications apportés à ce produit non expressément approuvés par la partie responsable de la conformité pourraient annuler le droit de l'utilisateur à utiliser le produit.</p> <p>Remarque : ce produit a été testé et jugé conforme aux limites d'un appareil numérique de classe B conformément à la partie 15 des règles de la FCC. Ces limites sont conçues pour fournir une protection raisonnable contre les interférences nuisibles dans une</p>

installation résidentielle.

Ce produit génère, utilise et peut émettre des radiofréquences. S'il n'est pas installé et utilisé conformément aux instructions, il peut provoquer des interférences nuisibles aux communications radio.

Cependant, rien ne garantit l'absence d'interférences dans une installation donnée. Si ce produit provoque des interférences nuisibles à la réception radio ou télévision, ce qui peut être vérifié en éteignant et en rallumant l'appareil, l'utilisateur est encouragé à essayer de corriger ces interférences en appliquant une ou plusieurs des mesures suivantes.

- Réorienter ou déplacer l'antenne de réception.
- Augmenter la distance entre le produit et le récepteur.
- Branchez le produit sur une prise d'un circuit différent de celui sur lequel le récepteur est branché.
- Consultez le revendeur ou un technicien radio/TV expérimenté pour obtenir de l'aide.

SAFETY INSTRUCTIONS

AVERTISSEMENT:

Veillez lire ce document avant d'utiliser ce produit. Le non-respect de ces instructions peut entraîner des blessures graves.

Précautions de montage

1. Assemblez uniquement conformément à ces instructions. Un assemblage incorrect peut créer des dangers.
2. Portez des lunettes de sécurité approuvées ANSI et des gants de travail robustes pendant l'assemblage.
3. Gardez la zone de montage propre et bien éclairée.
4. Gardez les spectateurs hors de la zone pendant le montage.
5. Ne pas monter si vous êtes fatigué ou sous l'influence de l'alcool, de drogues ou de médicaments.
6. De plus, même s'il est possible d'assembler la chaise soi-même, avoir une deuxième personne pour vous aider rend la tâche encore plus facile.
7. Les capacités du produit s'appliquent uniquement aux produits correctement et entièrement assemblés.
8. Assemblez-le sur une surface plane, de niveau, dure et lisse capable de supporter en toute sécurité le fauteuil inclinable en tissu .
9. Avant de commencer, veuillez vérifier qu'il ne manque aucune pièce dans le colis. En cas de problème, n'hésitez pas à nous contacter par e-mail ; nous vous aiderons dans les plus brefs délais.
10. Pour plus d'informations sur les pièces listées dans les pages suivantes, veuillez vous référer au schéma d'assemblage de ce manuel. Déballer et séparer toutes les pièces dans un espace de travail propre.

Précautions d'emploi

1. Utiliser uniquement comme prévu.
2. Inspectez avant chaque utilisation ; ne pas utiliser si des pièces sont desserrées ou endommagées.

CONSERVEZ CE MANUEL

PARTS LIST

 Seat cushion (A)*1	 Seat cushion (A)*1	 L Back (B)*1	 R Back (B)*1
 Middle Back (B)*1	 L Seat frame (C)*1	 R Seat frame (C)*1	 Middle Seat (C)*1
 F (L) Armrest bag (F)*1	 F (R) Armrest bag (F)*1	 L*1 Back ear	 R*1 Back ear
 Massage remote control board (G)*2	 Motor power supply (I)*2	 Power line (X)*2	 Glove*2
 Cup holder*2	 Screw (N)*8	 Spanner (O)*1	 Connector*4
 Screw (S)*4	 Spacer (T)*4		
 Under the frame			

ASSEMBLY STEP

STEP 1: Open the compression bag and remove the soft bag.

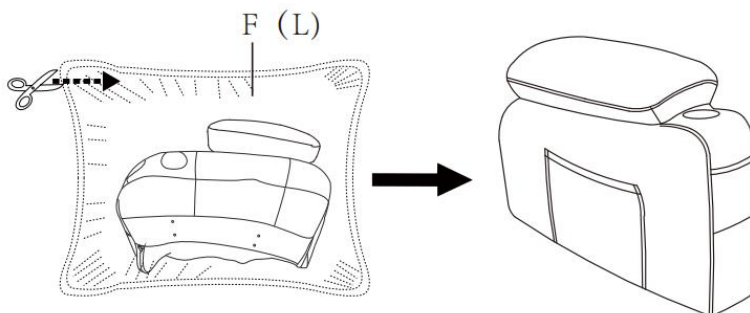

STEP 2: Repeat Step 1.

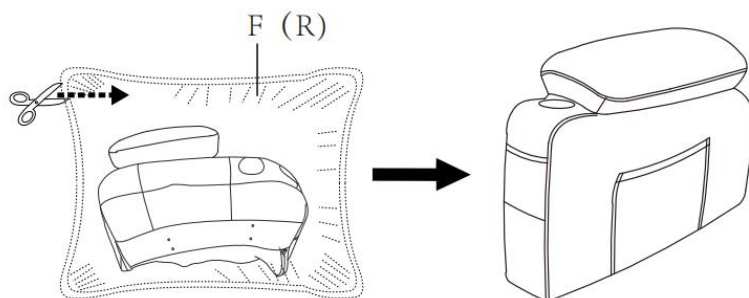

STEP 3: Fix the connector to the inside of the armrest with M6x16mm screws, paying attention to the direction of fixing the connector.

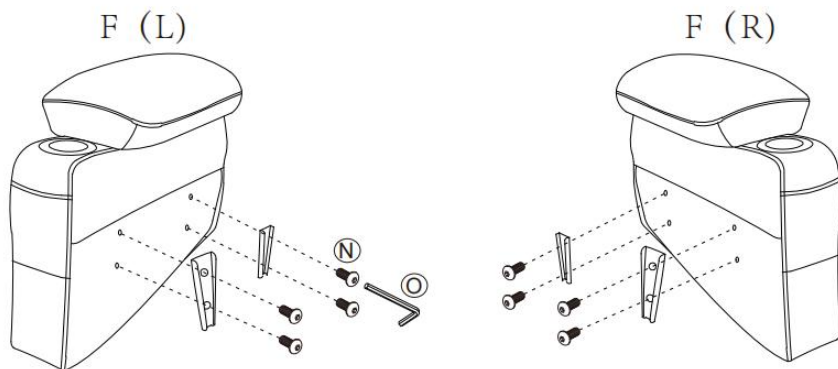

STEP 4: Fix the screws on both sides of the middle seat.

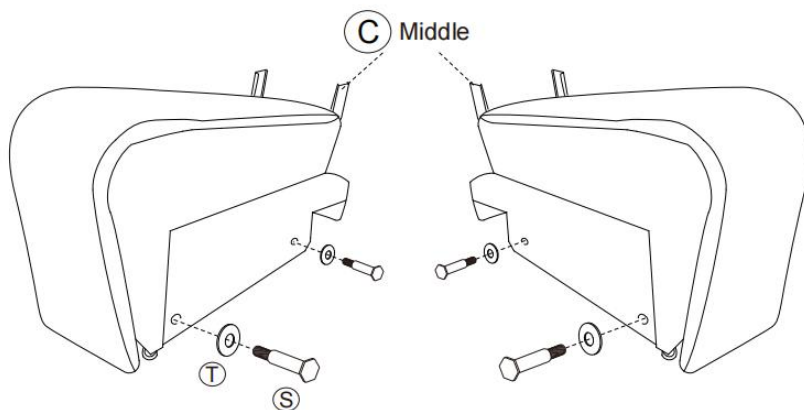

STEP 5:Place the cup holder into the groove.

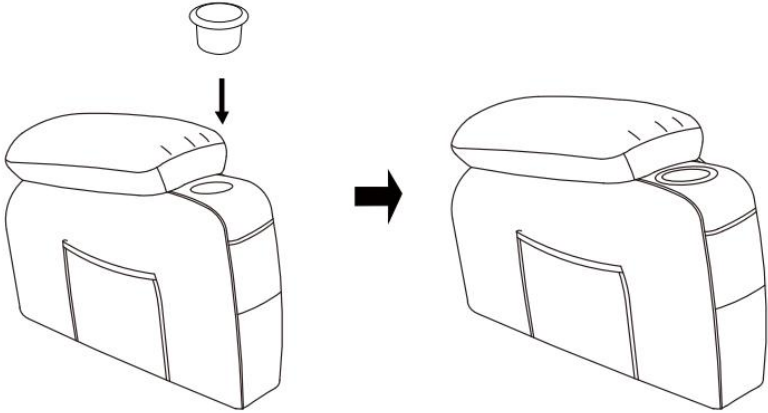

STEP 6:Insert arms so that they can fit into the seat, you will hear a “click” when they are engaged.

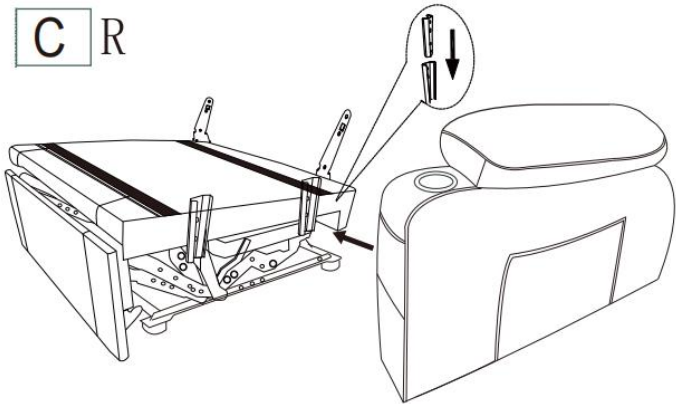

STEP7: Repeat Step 6

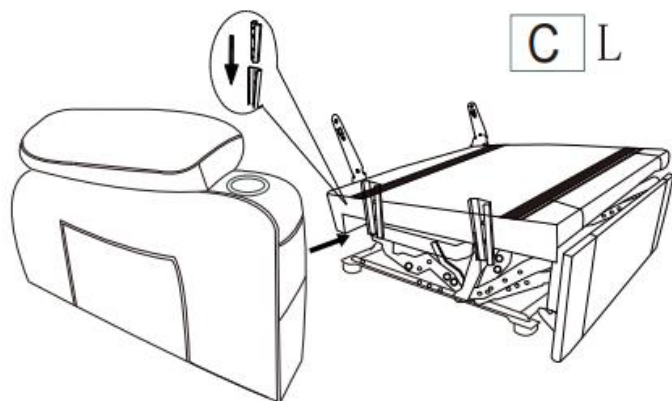

STEP8: Open seat bag A, stick the Velcro on the footboard, and stick the Velcro on the seat bag.

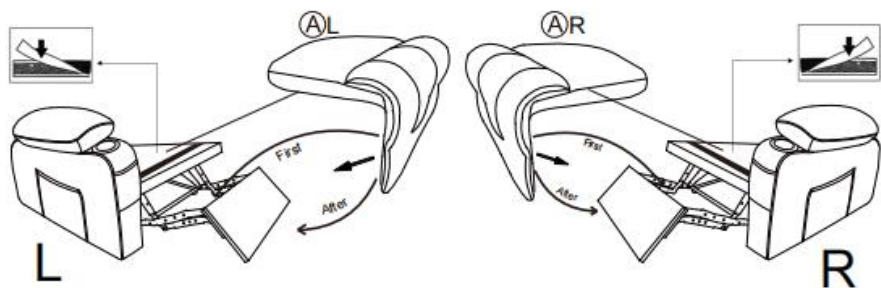

Note: First, power on, turn on the footrest, and then install the seat cushion

STEP 9: Plug the back pad into the seat frame, then connect the massager lines: white with white, red with red, black with the power lines, connect the massage line with the handcontroller.

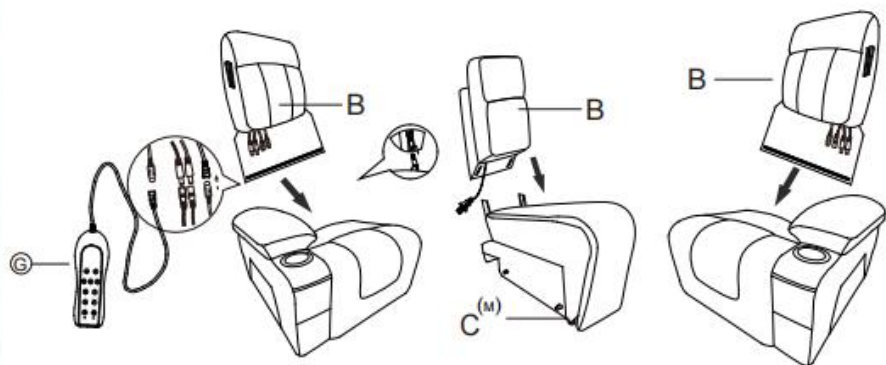

STEP 10: Install the back ears on both sides of the backrest.

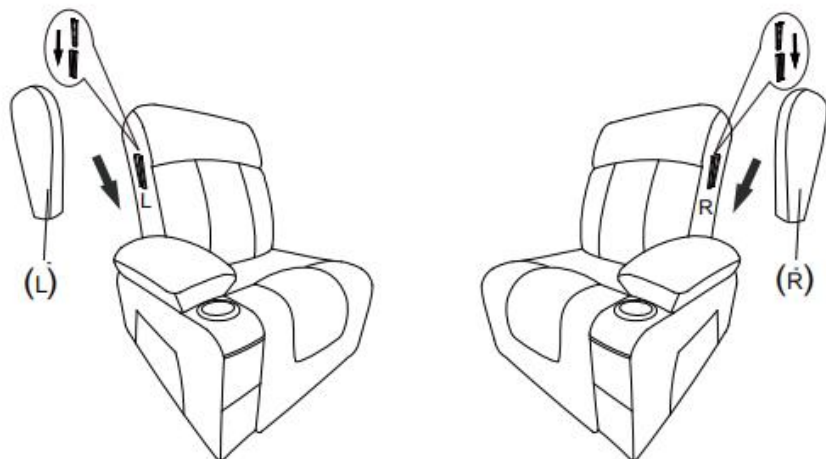

STEP 11 :Hang the middle position on the pendant slots on the left and right positions, and the three chairs can be connected together.

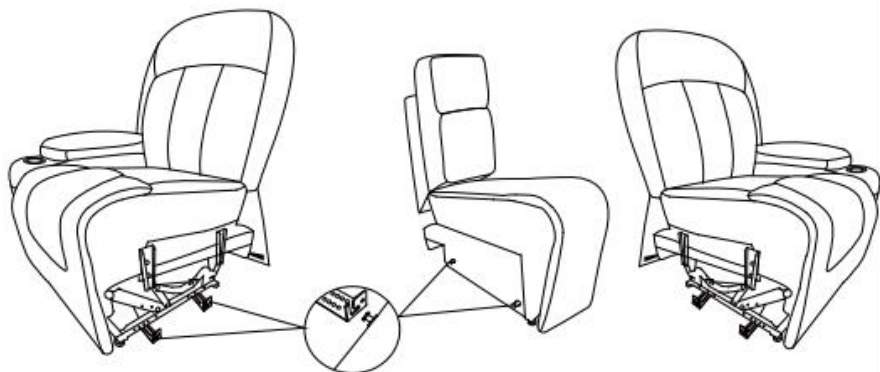

STEP 12 :Connect the power cord (X) to the power adapter (I),finally,stick up the Velcro below. Connect the power cord to the middle seat.

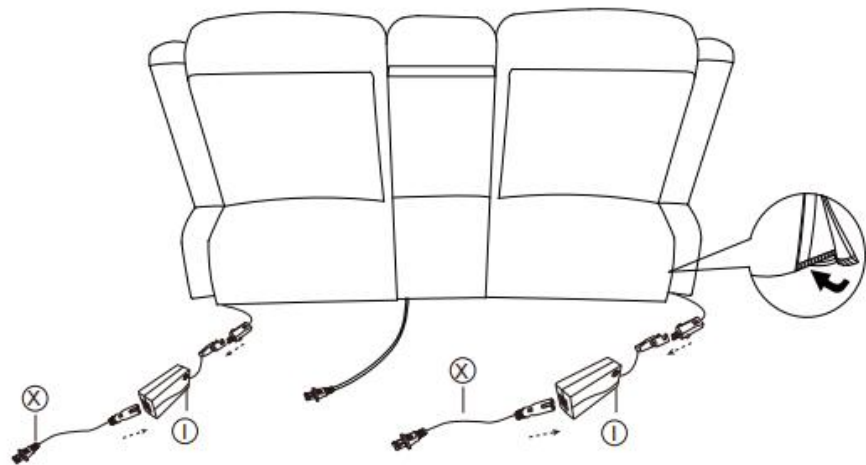

Congratulations! You've assembled
Your Sofa!

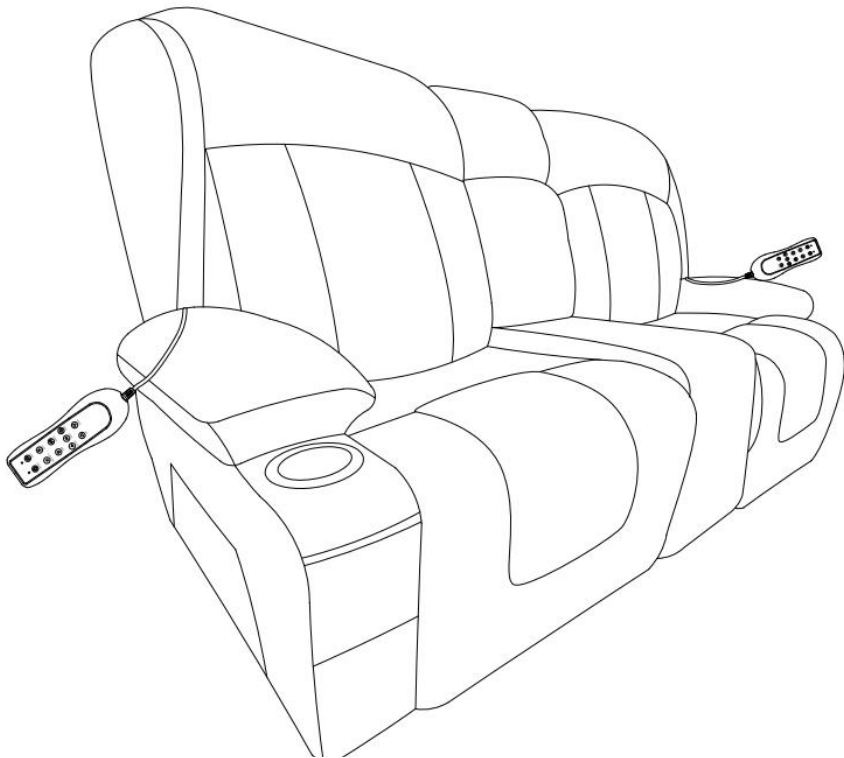

Note:

Since the backrest is packed in compression, after the product is installed, you need to tap and adjust the backrest which can help restore fullness. After two days, you will get a Overstuffed Recliners as picture shows.

OPERATING INSTRUCTION

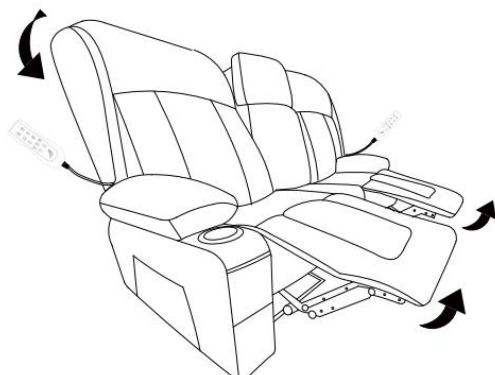

Press the switch to open the sofa

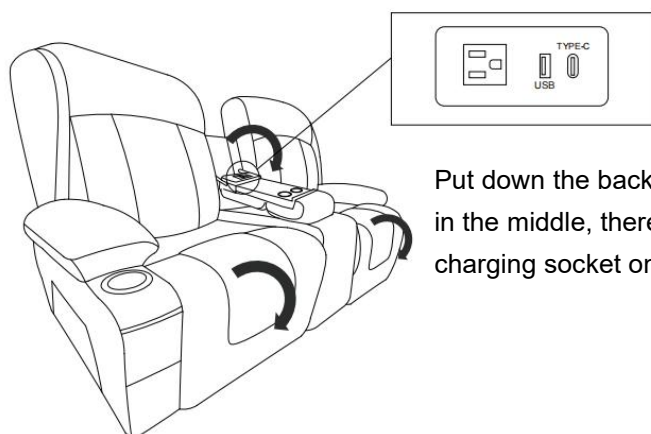

Put down the backrest in the middle, there is a charging socket on it.

Press the switch to lift the sofa

FUNCTION OF THE REMOTE CONTROL

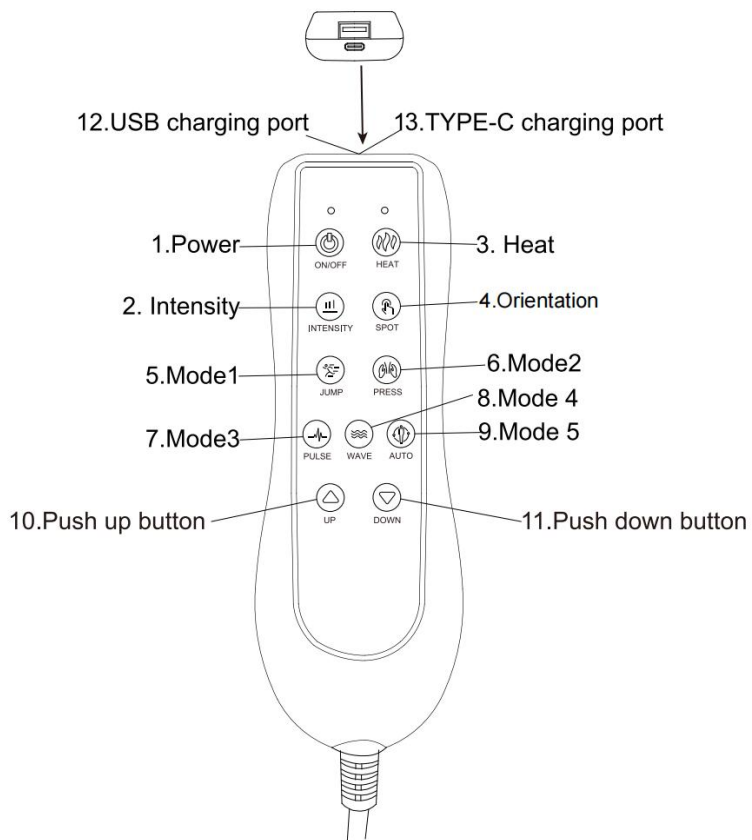

Product features

1. 4 Position, 8 Vibration motor
2. 5 motor vibration modes
3. Add hot spots to one part
4. The default shutdown duration is 15 minutes
5. 1 way electric push rod
6. USB/TYPE-C charging function

Function details

1. Switch on and off (Boot vibration full on (default strong/automatic mode))

2. Switch point by vibration intensity

3. Click heating switch circulation

4. Vibration positioning key

By default, the vibration is fully on when the machine is started

Sequence switch motor vibration in individual parts (back vibration → waist vibration → Leg vibration → Neck vibration → full open) cycle

5. Mode 1 (Skip mode)

6. Mode 2 (Press vibration mode)

7. Mode 3 (Pulse vibration mode)

8. Mode 4 (Wave vibration mode)

9. Mode 5 (Conventional vibration mode)

10. Long press the push rod upward

11. Long press the putter down

12. USB charging port

13. TYPE-C charging port

WARNINGS

- Asseyez-vous doucement sur la chaise. Pour éviter de basculer, ne vous jetez pas dessus. Inclinez-la lentement, en vous assurant qu'aucun enfant ni animal ne se trouve à proximité. Ne laissez pas les enfants jouer sur ou autour de la chaise, surtout lorsqu'elle est ouverte.
- Fermez complètement le fauteuil inclinable avant d'en sortir.
- Ne jamais s'asseoir sur le repose-pieds lorsqu'il est ouvert, même s'il s'agit d'un enfant.
- Pour éliminer le risque de basculement, ne vous asseyez pas sur les accoudoirs ou le repose-pieds de la chaise.
- Cette chaise est conçue pour être utilisée par un adulte à la fois.
- Veuillez interdire aux personnes souffrant des affections suivantes d'utiliser ce canapé : Les personnes présentant des symptômes graves de maladie cardiaque, d'hypertension artérielle, de thrombose cérébrale et autres personnes sensibles à la chaleur ou totalement insensibles à la chaleur, celles ayant des os fragiles ou ayant des problèmes de soutien de la taille, les femmes enceintes, les enfants et autres personnes pour lesquelles il a été déterminé qu'elles ne sont pas aptes à utiliser ce produit sous la supervision d'un médecin.
- Pour incliner complètement le canapé, assurez-vous bien que le canapé est bien incliné, vous devez placer le canapé à au moins 19 pouces du mur ou de tout autre obstacle.
- Le produit ne doit pas toucher l'eau, le feu, etc. Le produit ne doit pas non plus entrer en contact avec des objets tranchants (couteaux, clous, etc.)

MAINTENANCE MANUAL INSTRUCTIONS

- Pour éviter de le faire tomber, vous devez transporter le canapé avec précaution.
- Si vous trouvez de la saleté ou des taches sur le fauteuil, vaporisez un nettoyant spécifique pour canapés, puis essuyez-le avec une éponge

ou un chiffon. N'utilisez pas d'eau, d'eau savonneuse ou de nettoyant pour surfaces en bois cirées. Essuyez le canapé avec précaution et délicatesse.

- Ne placez pas le canapé dans une zone exposée directement au soleil et ne placez pas le canapé directement devant un climatiseur, cela décolorerait le revêtement et le rendrait cassant.

HOW TO DISASSEMBLE

Please find a strong tool to prod the small piece of metal grooves, then the backrest will be pulled out. The tool is not included.

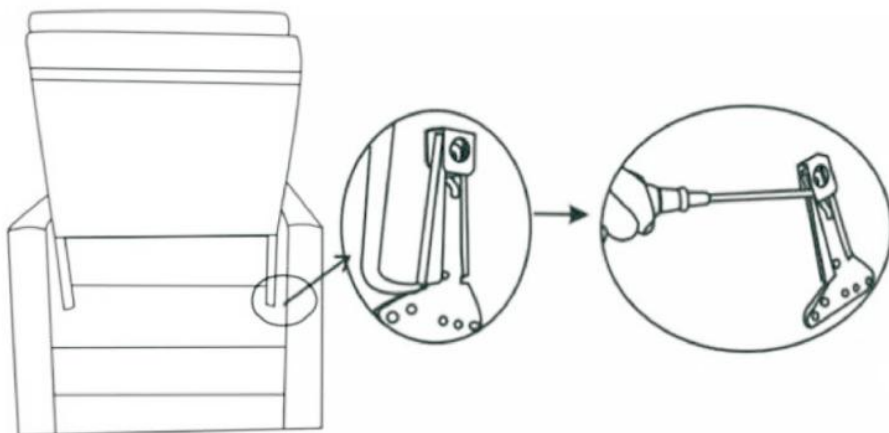

PRODUCT PARAMETER

Modèle	A1503-2DLR
Note(s)	100 V-240 V 50/60 Hz 1,5 A
Couleur principale	Brun
Capacité de charge d'un siège unique	330 livres
Dimensions du produit (P*L*H)	965*1830*1080mm
Poids net	75 kg

* Les produits tels que les spécifications, l'apparence et la conception sont sujets à modification sans préavis.

Fabricant : Shanghaimuxinmuyeyouxiangongsi

Adresse : Shuangchenglu 803nong11hao1602A-1609shi, baoshanqu, shanghai 200000 CN.

Importé en Australie : SIHAO PTY LTD. 1 ROKEVA STREET, ASTWOOD NSW 2122, Australie

Importé aux États-Unis : Sanven Technology Ltd. Suite 250, 9166 Anaheim Place, Rancho Cucamonga, CA 91730



E-CrossStu GmbH
Mainzer Landstr.69, 60329 Frankfurt am Main.



YH CONSULTING LIMITED.
C/O YH Consulting Limited Office 147, Centurion House, London Road, Staines-upon-Thames, Surrey, TW18 4AX



VEVOR

Affordable. Reliable. Home Improvement.

STOFF-LOVESEAT-RELAXSESSEL

MODELL: A1503-2DLR

Video mit Installationsanleitung für den
Stoff-Loveseat-Relaxsessel :

d2qc09r11gfuof.cloudfront.net/product/DBYSRSFDDKDAD7LT001/Stoff+Loveseat+Recliner+Installation+Instruction+Video.mp4



VEVOR



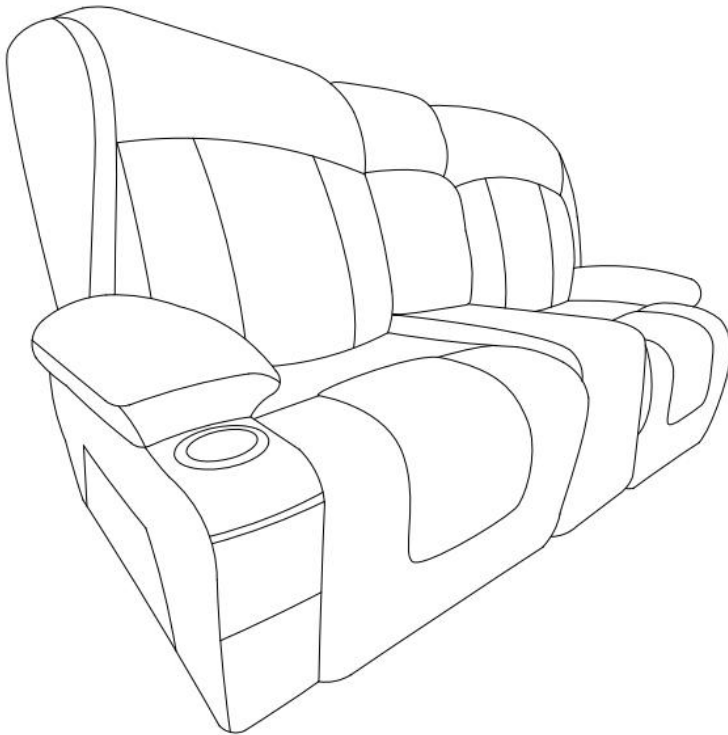

Affordable. Reliable. Home Improvement.

Fabric Loveseat
Recliner

MODELL: A1503-2DLR



Dies ist die Originalanleitung. Bitte lesen Sie alle Anweisungen sorgfältig durch, bevor Sie das Gerät in Betrieb nehmen. VEVOR behält sich das Recht vor, die Bedienungsanleitung klar und deutlich zu interpretieren. Das Aussehen des Produkts hängt vom gelieferten Produkt ab. Bitte haben Sie Verständnis dafür, dass wir Sie nicht erneut über Technologie- oder Software-Updates informieren.

	<p>Warnung: Um das Verletzungsrisiko zu verringern, muss der Benutzer die Bedienungsanleitung sorgfältig lesen.</p>
	<p>Compliance ist eine CE- Sicherheitszertifizierung .</p>
	<p>RICHTIGE ENTSORGUNG</p> <p>Dieses Produkt unterliegt der europäischen Richtlinie 2012/19/EG. Das Symbol einer durchgestrichenen Mülltonne weist darauf hin, dass dieses Produkt in der Europäischen Union einer getrennten Müllentsorgung unterliegt. Dies gilt für das Produkt und alle mit diesem Symbol gekennzeichneten Zubehörteile. Entsprechend gekennzeichnete Produkte dürfen nicht im Hausmüll entsorgt werden, sondern müssen an einer Sammelstelle für das Recycling von elektrischen und elektronischen Geräten abgegeben werden .</p>
	<p>Warnung – Nur zur Verwendung in Innenräumen</p>
	<p>FCC-Informationen:</p> <p>VORSICHT: Änderungen oder Modifikationen, die nicht ausdrücklich von der für die Konformität verantwortlichen Partei genehmigt wurden, können zum Erlöschen der Berechtigung des Benutzers zum Betrieb des Geräts führen!</p> <p>Dieses Gerät entspricht Teil 15 der FCC-Bestimmungen. Der Betrieb unterliegt den folgenden zwei Bedingungen:</p> <ol style="list-style-type: none"> 1) Dieses Produkt kann schädliche Störungen verursachen. 2) Dieses Produkt muss alle empfangenen Störungen tolerieren, einschließlich Störungen, die einen unerwünschten Betrieb verursachen können. <p>WARNUNG: Änderungen oder Modifikationen an diesem Produkt, die nicht ausdrücklich von der für die Konformität verantwortlichen Partei genehmigt wurden, können zum Erlöschen der Berechtigung des Benutzers zum Betrieb des Produkts führen.</p> <p>Hinweis: Dieses Produkt wurde getestet und entspricht den Grenzwerten für digitale Geräte der Klasse B gemäß Teil 15 der</p>

FCC-Bestimmungen. Diese Grenzwerte sollen einen angemessenen Schutz vor schädlichen Störungen bei der Installation in Wohngebieten bieten.

Dieses Produkt erzeugt, verwendet und strahlt Hochfrequenzenergie ab. Bei unsachgemäßer Installation und Verwendung kann es zu Störungen des Funkverkehrs kommen. Es besteht jedoch keine Garantie dafür, dass bei einer bestimmten Installation keine Störungen auftreten. Sollte dieses Produkt Störungen des Radio- oder Fernsehempfangs verursachen (was durch Ein- und Ausschalten des Produkts überprüft werden kann), wird dem Benutzer empfohlen, die Störungen durch eine oder mehrere der folgenden Maßnahmen zu beheben.

- Richten Sie die Empfangsantenne neu aus oder verlegen Sie den Standort.
- Vergrößern Sie den Abstand zwischen Produkt und Empfänger.
- Schließen Sie das Produkt an eine Steckdose eines anderen Stromkreises an als den Empfänger.
- Wenden Sie sich an den Händler oder einen erfahrenen Radio-/Fernsehtechniker, um Hilfe zu erhalten.

SAFETY INSTRUCTIONS

WARNUNG:

Lesen Sie dieses Material, bevor Sie dieses Produkt verwenden. Andernfalls kann es zu schweren Verletzungen kommen.

Vorsichtsmaßnahmen bei der Montage

1. Führen Sie die Montage ausschließlich gemäß dieser Anleitung durch. Eine unsachgemäße Montage kann zu Gefahren führen.
2. Tragen Sie während der Montage eine ANSI-zugelassene Schutzbrille und strapazierfähige Arbeitshandschuhe.
3. Halten Sie den Versammlungsbereich sauber und gut beleuchtet.
4. Halten Sie während der Montage unbeteiligte Personen vom Bereich fern.
5. Nicht zusammenbauen, wenn Sie müde sind oder unter dem Einfluss von Alkohol, Drogen oder Medikamenten stehen.
6. Obwohl Sie den Stuhl auch alleine zusammenbauen können, ist es mit der Hilfe einer zweiten Person noch einfacher.
7. Die Produkteigenschaften gelten nur für ordnungsgemäß und vollständig montierte Produkte.
8. Stoff -Loveseat-Recliner sicher tragen kann .
9. Bevor Sie beginnen, überprüfen Sie bitte, ob Teile im Paket fehlen. Sollten Probleme auftreten, schreiben Sie uns bitte eine E-Mail. Wir helfen Ihnen schnellstmöglich weiter.
10. Weitere Informationen zu den auf den folgenden Seiten aufgeführten Teilen finden Sie im Montagediagramm dieses Handbuchs. Packen Sie alle Teile an einem sauberen Arbeitsbereich aus und trennen Sie sie.

Vorsichtsmaßnahmen treffen

1. Nur bestimmungsgemäß verwenden.
2. Vor jedem Gebrauch prüfen; nicht verwenden, wenn Teile lose oder beschädigt sind.

BEWAHREN SIE DIESES HANDBUCH AUF

PARTS LIST

 Seat cushion (A)*1	 Seat cushion (A)*1	 L Back (B)*1	 R Back (B)*1
 Middle Back (B)*1	 L Seat frame (C)*1	 R Seat frame (C)*1	 Middle Seat (C)*1
 F (L) Armrest bag (F)*1	 F (R) Armrest bag (F)*1	 L*1 Back ear	 R*1 Back ear
 Massage remote control board (G)*2	 Motor power supply (I)*2	 Power line (X)*2	 Glove *2
 Cup holder *2	 Screw (N)*8	 Spanner (O)*1	 Connector *4
 Screw (S)*4	 Spacer (T)*4		
<div style="display: flex; align-items: center;"> <div style="margin-right: 20px;"> <p>Under the frame</p>  </div> <div style="margin-right: 20px;">  </div> <div>   </div> </div>			

ASSEMBLY STEP

STEP 1: Open the compression bag and remove the soft bag.

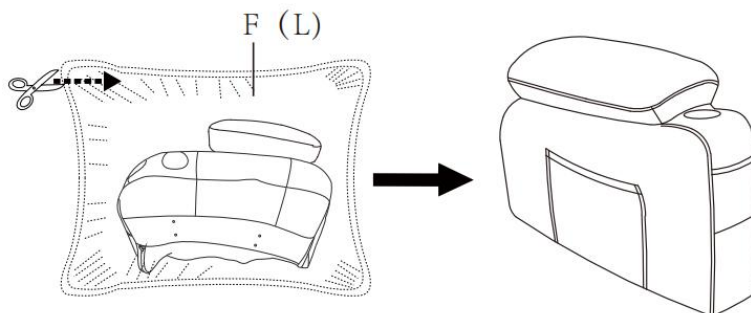

STEP 2: Repeat Step 1.

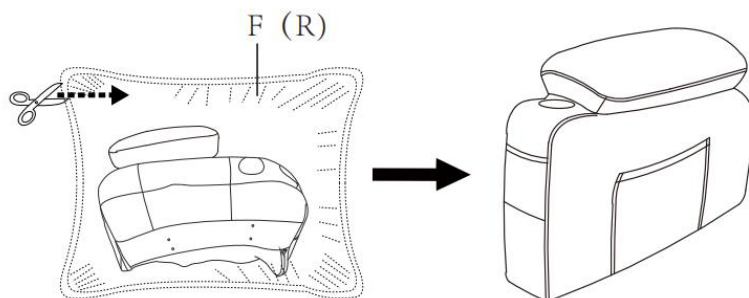

STEP 3: Fix the connector to the inside of the armrest with M6x16mm screws, paying attention to the direction of fixing the connector.

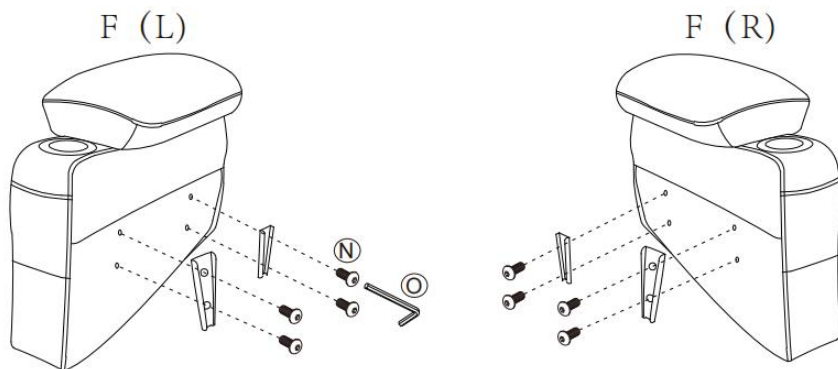

STEP 4: Fix the screws on both sides of the middle seat.

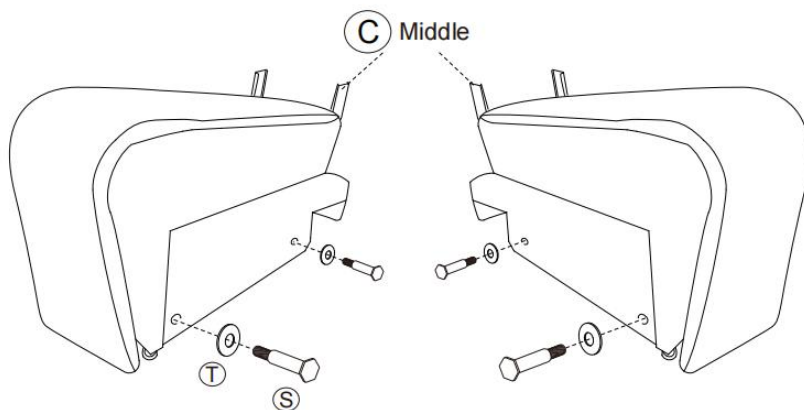

STEP 5:Place the cup holder into the groove.

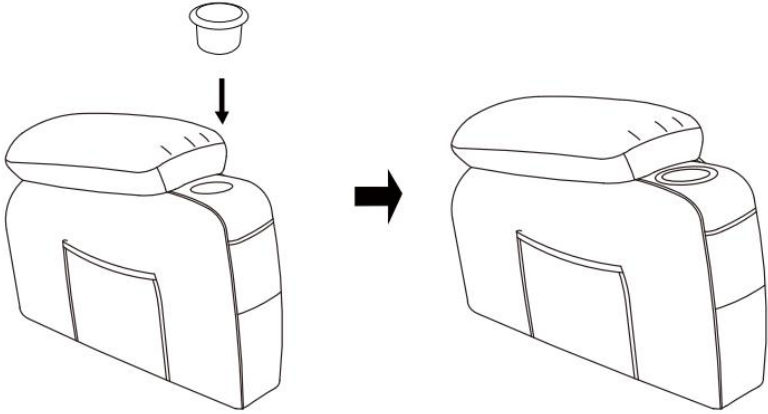

STEP 6:Insert arms so that they can fit into the seat, you will hear a “click” when they are engaged.

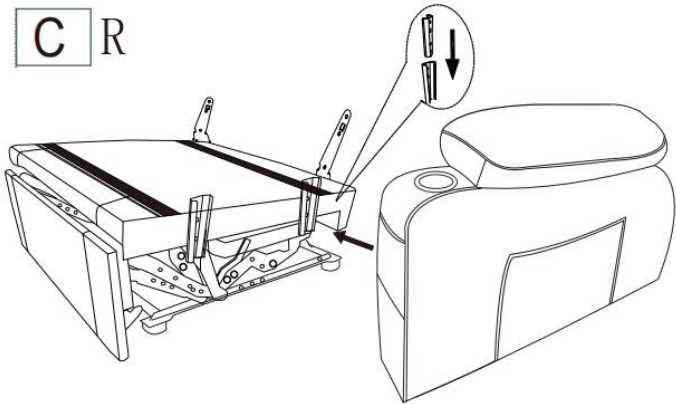

STEP7: Repeat Step 6

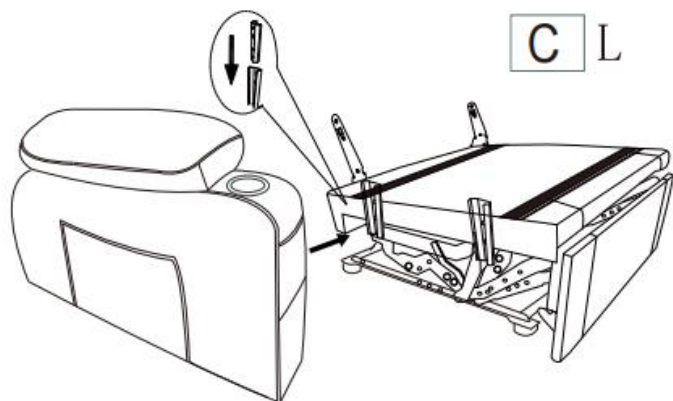

STEP8: Open seat bag A, stick the Velcro on the footboard, and stick the Velcro on the seat bag.

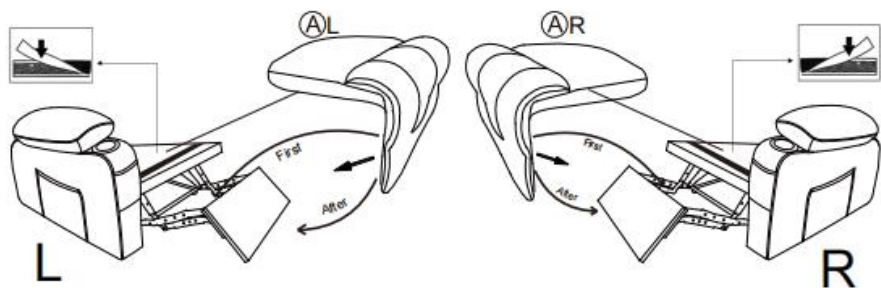

Note: First, power on, turn on the footrest, and then install the seat cushion

STEP 9: Plug the back pad into the seat frame, then connect the massager lines: white with white, red with red, black with the power lines, connect the massage line with the handcontroller.

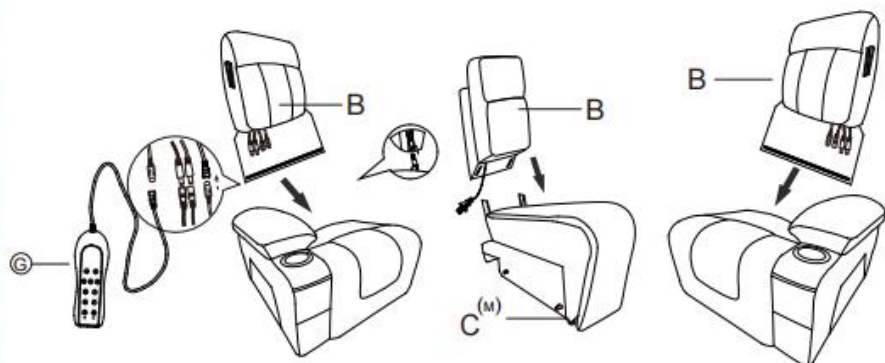

STEP 10: Install the back ears on both sides of the backrest.

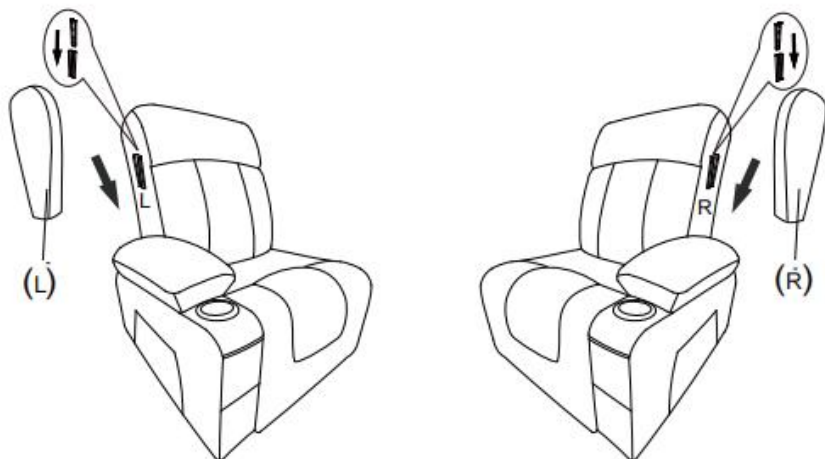

STEP 11 :Hang the middle position on the pendant slots on the left and right positions, and the three chairs can be connected together.

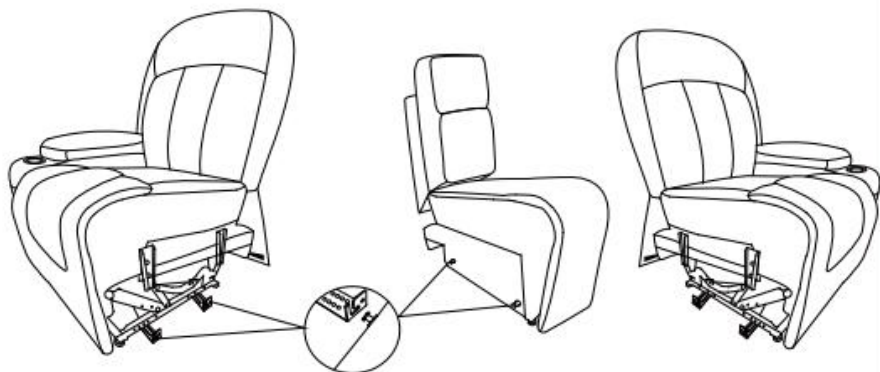

STEP 12 :Connect the power cord (X) to the power adapter (I),finally,stick up the Velcro below.Connect the power cord to the middle seat.

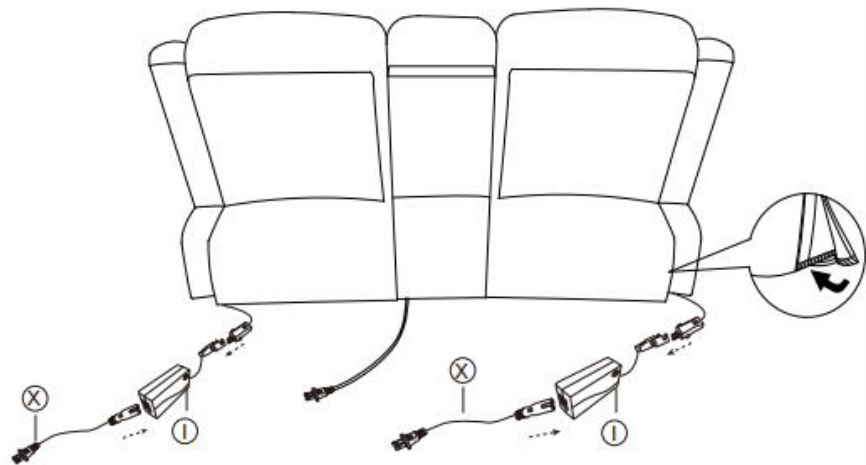

Congratulations! You've assembled
Your Sofa!

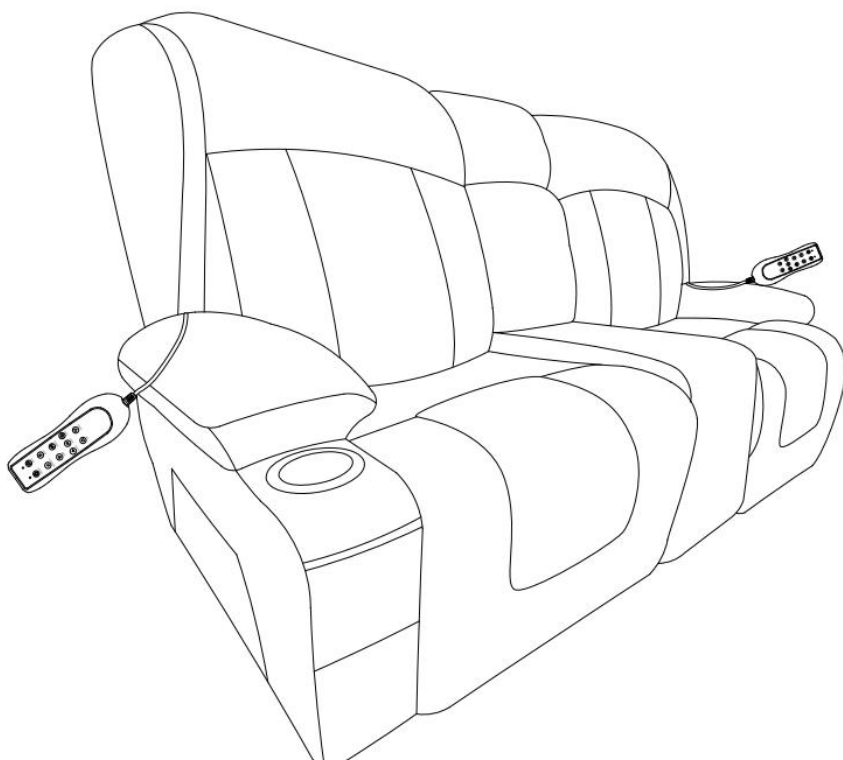

Note:

Since the backrest is packed in compression, after the product is installed, you need to tap and adjust the backrest which can help restore fullness. After two days, you will get a Overstuffed Recliners as picture shows.

OPERATING INSTRUCTION

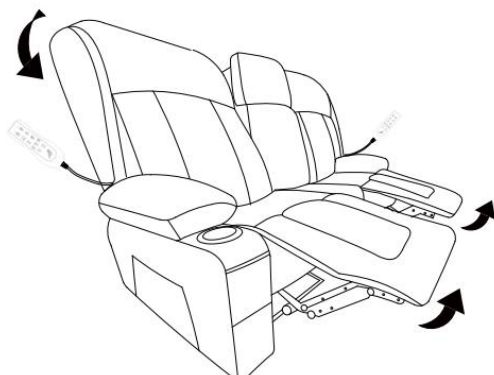

Press the switch to open the sofa

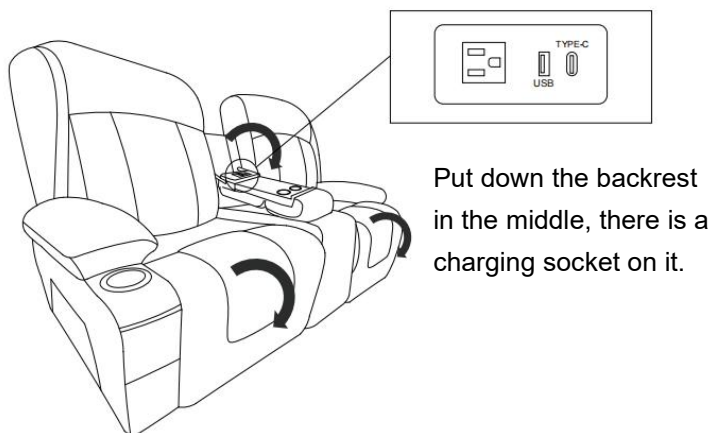

Press the switch to lift the sofa

FUNCTION OF THE REMOTE CONTROL

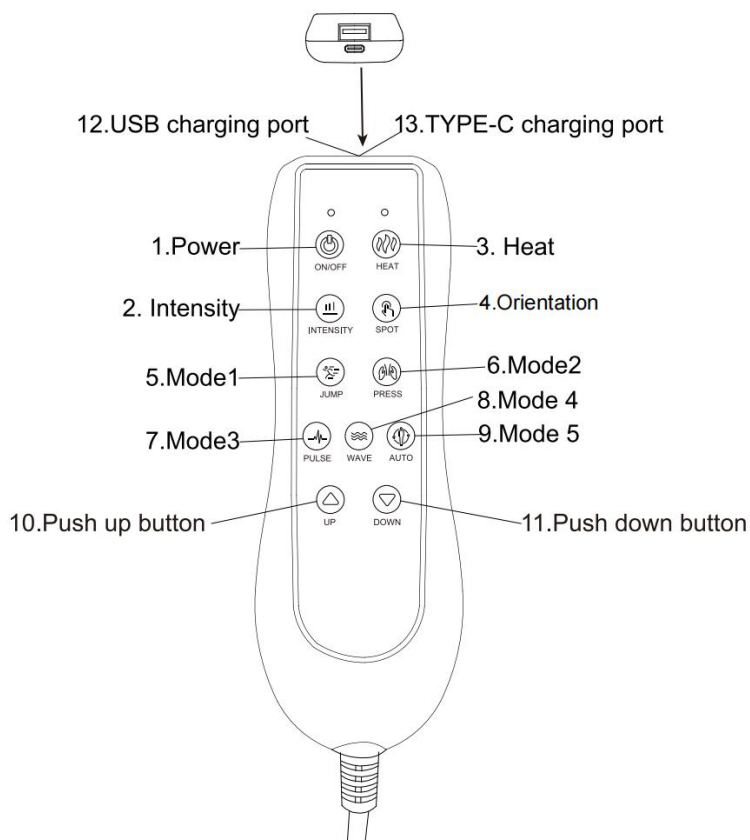

Product features

1. 4 Position, 8 Vibration motor
2. 5 motor vibration modes
3. Add hot spots to one part
4. The default shutdown duration is 15 minutes
5. 1 way electric push rod
6. USB/TYPE-C charging function

Function details

1. Switch on and off (Boot vibration full on (default strong/automatic mode))

2. Switch point by vibration intensity

3. Click heating switch circulation

4. Vibration positioning key

By default, the vibration is fully on when the machine is started

Sequence switch motor vibration in individual parts (back vibration → waist vibration → Leg vibration → Neck vibration → full open) cycle

5. Mode 1 (Skip mode)

6. Mode 2 (Press vibration mode)

7. Mode 3 (Pulse vibration mode)

8. Mode 4 (Wave vibration mode)

9. Mode 5 (Conventional vibration mode)

10. Long press the push rod upward

11. Long press the putter down

12. USB charging port

13. TYPE-C charging port

WARNINGS

- Setzen Sie sich vorsichtig in den Stuhl. Um ein Umkippen zu vermeiden, werfen Sie sich nicht in den Stuhl. Bringen Sie den Stuhl langsam in die Liegeposition und achten Sie darauf, dass sich keine Kinder oder Haustiere in der Nähe befinden. Erlauben Sie Kindern nicht, auf oder um den Stuhl herum zu spielen, insbesondere wenn er geöffnet ist.
- Schließen Sie den Ruhesessel vollständig, bevor Sie aussteigen.
- Setzen Sie sich niemals auf die geöffnete Fußstütze, auch nicht, wenn es sich um ein Kind handelt.
- Um die Gefahr des Umkippens zu vermeiden, setzen Sie sich nicht auf die Arm- oder Fußstützen des Stuhls.
- Dieser Stuhl ist für die gleichzeitige Nutzung durch einen Erwachsenen konzipiert.
- Bitte verbieten Sie die Nutzung dieses Sofas Personen mit den folgenden Beschwerden: Personen mit schweren Symptomen einer Herzerkrankung, hohem Blutdruck, Hirnthrombose und anderen Personen, die hitzeempfindlich oder völlig unempfindlich gegenüber Hitze sind, Personen mit brüchigen Knochen oder Problemen mit der Taillenunterstützung, schwangeren Frauen, Kindern und anderen Personen, bei denen unter ärztlicher Aufsicht festgestellt wurde, dass sie für die Nutzung dieses Produkts nicht geeignet sind.
- Um das Sofa vollständig zurückzulehnen, stellen Sie sicher, dass es gut steht. Stellen Sie es mindestens 48 cm von der Wand oder anderen Hindernissen entfernt auf.
- Das Produkt darf nicht mit Wasser, Feuer usw. in Berührung kommen. Das Produkt darf auch nicht mit scharfen Gegenständen (Messern, Nägeln usw.) in Berührung kommen.

MAINTENANCE MANUAL INSTRUCTIONS

- Um ein Herunterfallen zu vermeiden, sollten Sie das Sofa vorsichtig tragen.

- Sollten Sie Schmutz und/oder Flecken auf dem Sessel finden, sprühen Sie das Sofa mit einem speziellen Sofareiniger ein und wischen Sie den Schmutz anschließend mit einem Schwamm oder Tuch ab. Verwenden Sie kein Wasser, Seifenlauge oder Reiniger auf gewachsenen Holzflächen. Wischen Sie das Sofa vorsichtig und schonend ab.
- Stellen Sie das Sofa nicht an einen Ort mit direkter Sonneneinstrahlung und nicht direkt vor eine Klimaanlage, da dies die Polsterung ausbleicht und spröde macht.

HOW TO DISASSEMBLE

Please find a strong tool to prod the small piece of metal grooves, then the backrest will be pulled out. The tool is not included.

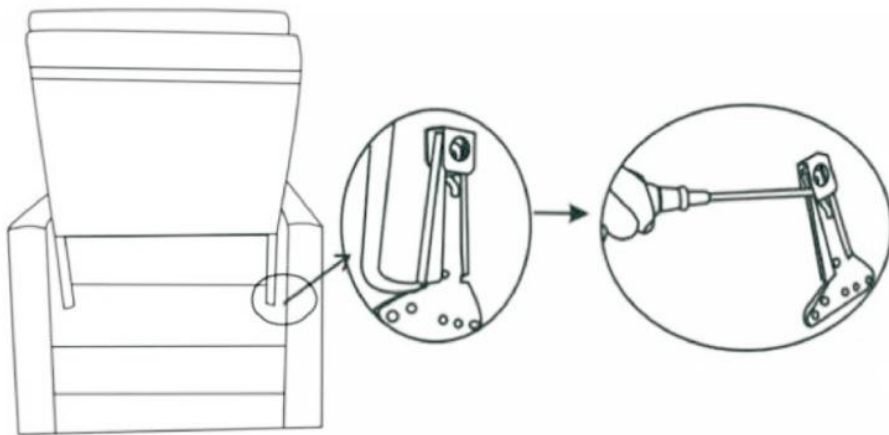

PRODUCT PARAMETER

Modell	A1503-2DLR
Bewertung(en)	100 V – 240 V, 50/60 Hz, 1,5 A
Hauptfarbe	Braun
Einzelstz-Tragfähigkeit	330 Pfund
Produktgröße (T*B*H)	965*1830*1080 mm
Nettogewicht	75 kg

* Produktspezifikationen, Aussehen und Design können ohne vorherige Ankündigung geändert werden.

Hersteller: Shanghaimuxinmuyeyouxiangongsi

Adresse: Shuangchenglu 803nong11hao1602A-1609shi, baoshanqu, Shanghai 200000 CN.

Importiert nach AUS: SIHAO PTY LTD. 1 ROKEVA STREETEASTWOOD NSW 2122 Australien

Importiert in die USA: Sanven Technology Ltd. Suite 250, 9166 Anaheim Place, Rancho Cucamonga, CA 91730

EC	REP
-----------	------------

E-CrossStu GmbH
Mainzer Landstr.69, 60329 Frankfurt am Main.

UK	REP
-----------	------------

YH CONSULTING LIMITED.
C/O YH Consulting Limited Office 147, Centurion House, London Road, Staines-upon-Thames, Surrey, TW18 4AX



VEVOR

Affordable. Reliable. Home Improvement.

FOTEL ROZKŁADANY Z TKANINY

MODEL: A1503-2DLR

Instrukcja montażu rozkładanego fotela dwuosobowego z tkaniny :

d2qc09rl1gfuof.cloudfront.net/product/DDBYSRSFDDKDAD7LT001/fabric+Loveseat+Recliner+Installation+Instruction+Video.mp4



VEVOR



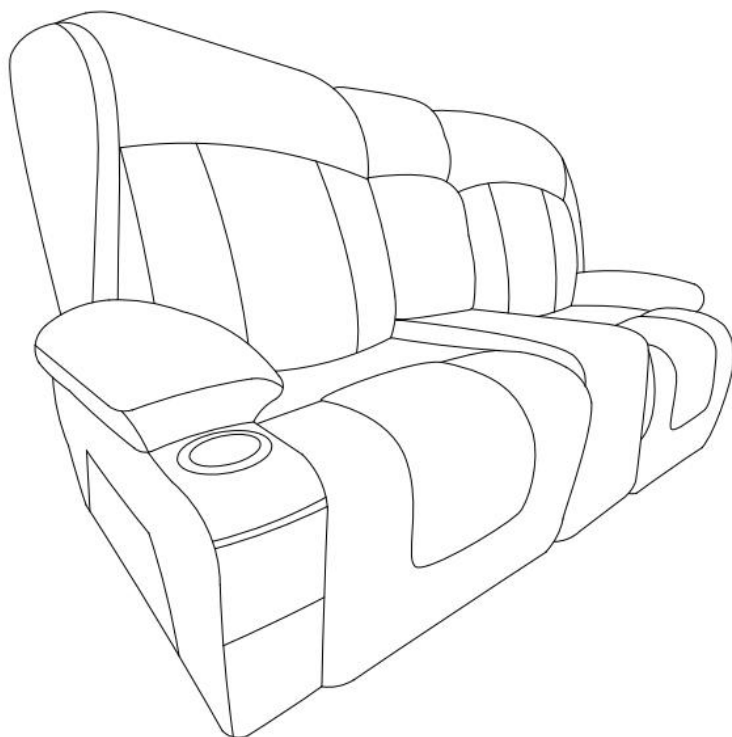

Affordable. Reliable. Home Improvement.

Fabric Loveseat
Recliner

MODEL: A1503-2DLR



To jest oryginalna instrukcja obsługi. Przed użyciem prosimy o dokładne zapoznanie się z treścią instrukcji. Firma VEVOR zastrzega sobie prawo do jednoznacznej interpretacji niniejszej instrukcji obsługi. Wygląd produktu zależy od stanu, w jakim go otrzymali Państwo. Prosimy o wyrozumiałość, ale nie będziemy Państwa ponownie informować o aktualizacjach technologicznych lub oprogramowania naszego produktu.

	<p>Ostrzeżenie: Aby zminimalizować ryzyko obrażeń, użytkownik powinien uważnie przeczytać instrukcję obsługi.</p>
	<p>Zgodność oznacza certyfikat bezpieczeństwa CE .</p>
	<p>PRAWIDŁOWA UTYLIZACJA</p> <p>Niniejszy produkt podlega przepisom Dyrektywy Europejskiej 2012/19/WE. Symbol przekreślonego kosza na śmieci na kółkach oznacza, że produkt wymaga selektywnej zbiórki odpadów w Unii Europejskiej. Dotyczy to produktu i wszystkich akcesoriów oznaczonych tym symbolem. Produktów oznaczonych tym symbolem nie wolno wyrzucać razem z normalnymi odpadami domowymi, lecz należy je dostarczyć do punktu zbiórki urządzeń elektrycznych i elektronicznych przeznaczonych do recyklingu .</p>
	<p>Ostrzeżenie – wyłącznie do użytku wewnątrz pomieszczeń</p>
	<p>Informacje FCC:</p> <p>UWAGA: Zmiany lub modyfikacje, które nie zostały wyraźnie zatwierdzone przez stronę odpowiedzialną za zgodność, mogą spowodować unieważnienie prawa użytkownika do korzystania ze sprzętu!</p> <p>To urządzenie jest zgodne z częścią 15 przepisów FCC. Jego eksploatacja podlega dwóm następującym warunkom:</p> <ol style="list-style-type: none"> 1) Ten produkt może powodować szkodliwe zakłócenia. 2) Produkt ten musi akceptować wszelkie odbierane zakłócenia, w tym zakłócenia mogące powodować niepożądane działanie. <p>OSTRZEŻENIE: Wszelkie zmiany lub modyfikacje tego produktu, które nie zostały wyraźnie zatwierdzone przez stronę odpowiedzialną za zgodność, mogą spowodować unieważnienie prawa użytkownika do korzystania z produktu.</p> <p>Uwaga: Ten produkt został przetestowany i uznany za zgodny z ograniczeniami dla urządzeń cyfrowych klasy B zgodnie z częścią 15 przepisów FCC. Ograniczenia te mają na celu zapewnienie</p>

odpowiedniej ochrony przed szkodliwymi zakłóceniami w instalacjach domowych.

Ten produkt generuje, wykorzystuje i może emitować energię o częstotliwości radiowej i jeśli nie zostanie zainstalowany i używany zgodnie z instrukcją, może powodować szkodliwe zakłócenia w komunikacji radiowej. Nie ma jednak gwarancji, że zakłócenia nie wystąpią w danej instalacji. Jeśli ten produkt powoduje szkodliwe zakłócenia w odbiorze sygnału radiowego lub telewizyjnego, co można sprawdzić, wyłączając i włączając urządzenie, zaleca się, aby użytkownik spróbował skorygować zakłócenia, stosując jeden lub kilka z poniższych środków.

- Zmiana orientacji lub położenia anteny odbiorczej.
- Zwiększ odległość między produktem i odbiornikiem.
- Podłączyć produkt do gniazdka w innym obwodzie niż ten, do którego podłączony jest odbiornik.
- Aby uzyskać pomoc, skontaktuj się ze sprzedawcą lub doświadczonym technikiem radiowo-telewizyjnym.

SAFETY INSTRUCTIONS

OSTRZEŻENIE:

Przeczytaj ten materiał przed użyciem produktu. Nieprzestrzeganie tego zalecenia może spowodować poważne obrażenia.

Środki ostrożności podczas montażu

1. Montaż należy wykonywać wyłącznie zgodnie z niniejszą instrukcją. Nieprawidłowy montaż może stwarzać zagrożenie.
2. Podczas montażu należy nosić okulary ochronne zatwierdzone przez ANSI oraz wytrzymałe rękawice robocze.
3. Utrzymuj miejsce zgromadzenia w czystości i zapewnij dobre oświetlenie.
4. Nie dopuszczaj osób postronnych na teren montażu w trakcie jego trwania.
5. Nie przychodź na zgromadzenie, jeśli jesteś zmęczony lub pod wpływem alkoholu, narkotyków lub leków.
6. Chociaż możliwe jest samodzielne zmontowanie krzesła, to pomoc drugiej osoby sprawi, że będzie to jeszcze łatwiejsze.
7. Możliwości produktu odnoszą się wyłącznie do produktów prawidłowo i całkowicie zmontowanych.
8. Zmontuj na płaskiej, równej, twardej i gładkiej powierzchni, która będzie w stanie bezpiecznie utrzymać rozkładaną sofę F abric Doubleseat.
9. Zanim zaczniesz, sprawdź, czy w opakowaniu nie brakuje żadnych elementów. W razie jakichkolwiek problemów, prosimy o kontakt mailowy, a pomożemy Ci jak najszybciej.
10. Aby uzyskać dodatkowe informacje dotyczące części wymienionych na kolejnych stronach, zapoznaj się ze schematem montażu w niniejszej instrukcji. Rozpakuj i rozdziel wszystkie części w czystym miejscu pracy.

Zachowaj środki ostrożności

1. Stosować wyłącznie zgodnie z przeznaczeniem.
2. Przed każdym użyciem należy przeprowadzić kontrolę. Nie używać

produktu, jeśli części są luźne lub uszkodzone.

ZAPISZ TĘ INSTRUKCJĘ

PARTS LIST

 Seat cushion (A)*1	 Seat cushion (A)*1	 L Back (B)*1	 R Back (B)*1
 Middle Back (B)*1	 L Seat frame (C)*1	 R Seat frame (C)*1	 Middle Seat (C)*1
 F (L) Armrest bag (F)*1	 F (R) Armrest bag (F)*1	 L*1 Back ear	 R*1 Back ear
 Massage remote control board (G)*2	 Motor power supply (I)*2	 Power line (X)*2	 Glove*2
 Cup holder*2	 Screw (N)*8	 Spanner (O)*1	 Connector*4
 Screw (S)*4	 Spacer (T)*4		
 Under the frame			

ASSEMBLY STEP

STEP 1: Open the compression bag and remove the soft bag.

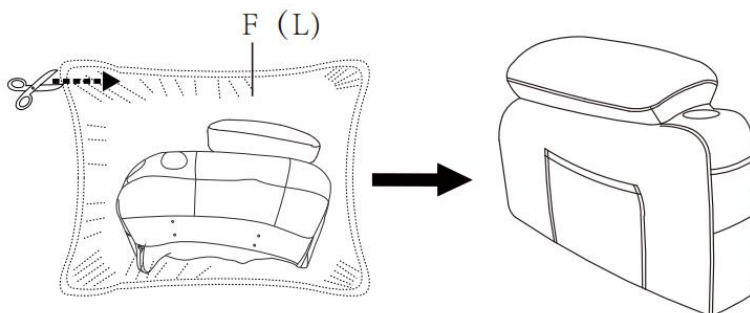

STEP 2: Repeat Step 1.

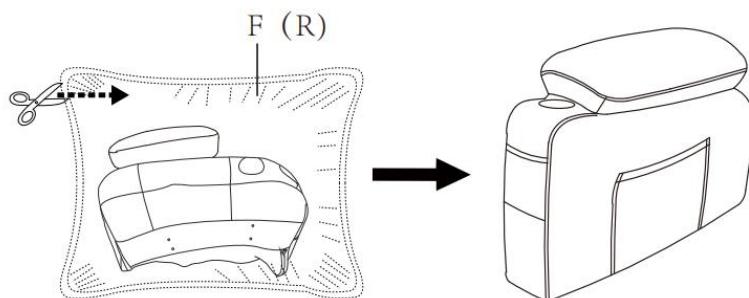

STEP 3: Fix the connector to the inside of the armrest with M6x16mm screws, paying attention to the direction of fixing the connector.

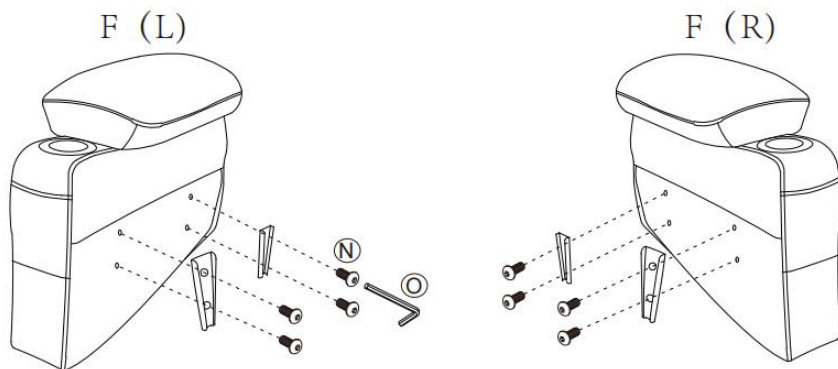

STEP 4: Fix the screws on both sides of the middle seat.

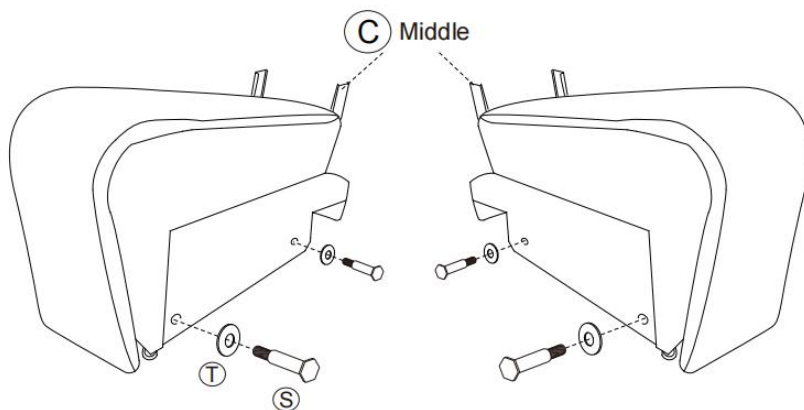

STEP 5:Place the cup holder into the groove.

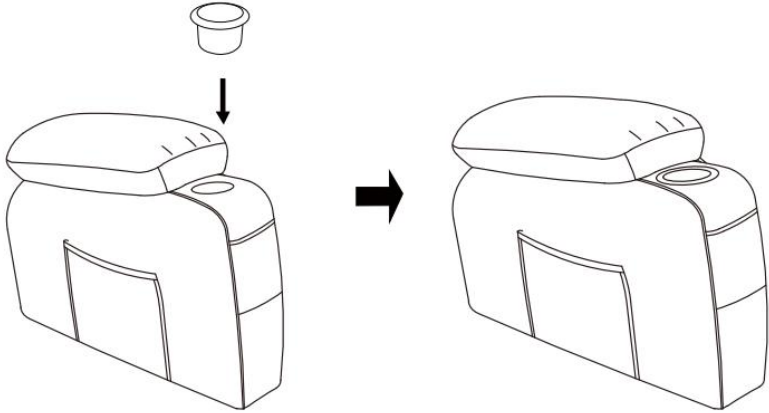

STEP 6:Insert arms so that they can fit into the seat, you will hear a “click” when they are engaged.

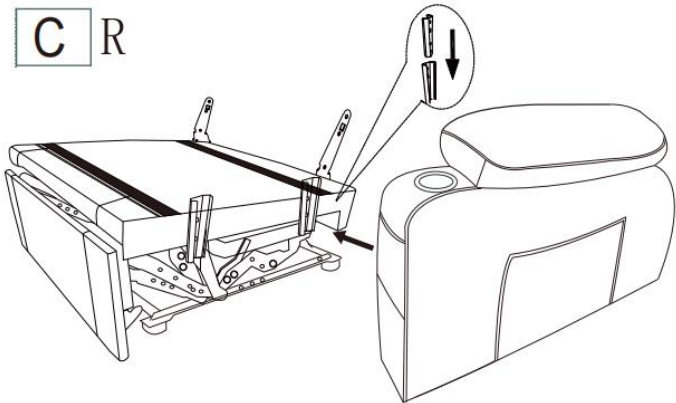

STEP7: Repeat Step 6

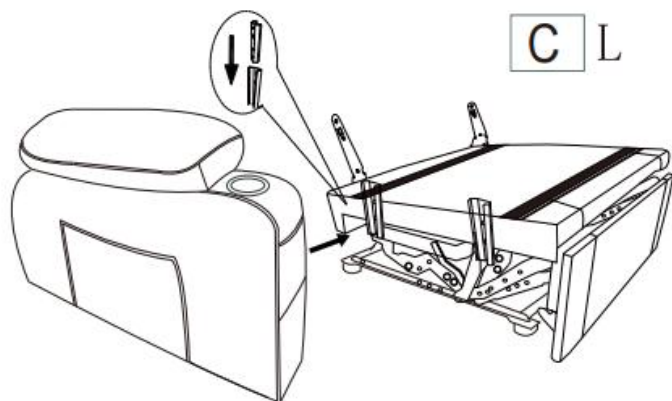

STEP8: Open seat bag A, stick the Velcro on the footboard, and stick the Velcro on the seat bag.

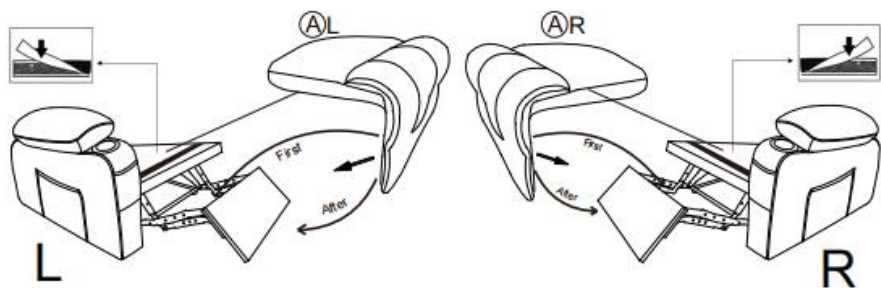

Note: First, power on, turn on the footrest, and then install the seat cushion

STEP 9: Plug the back pad into the seat frame, then connect the massager lines: white with white, red with red, black with the power lines, connect the massage line with the handcontroller.

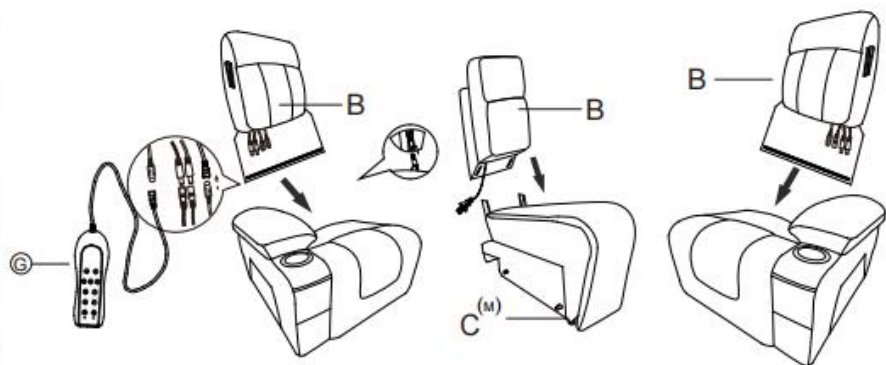

STEP 10: Install the back ears on both sides of the backrest.

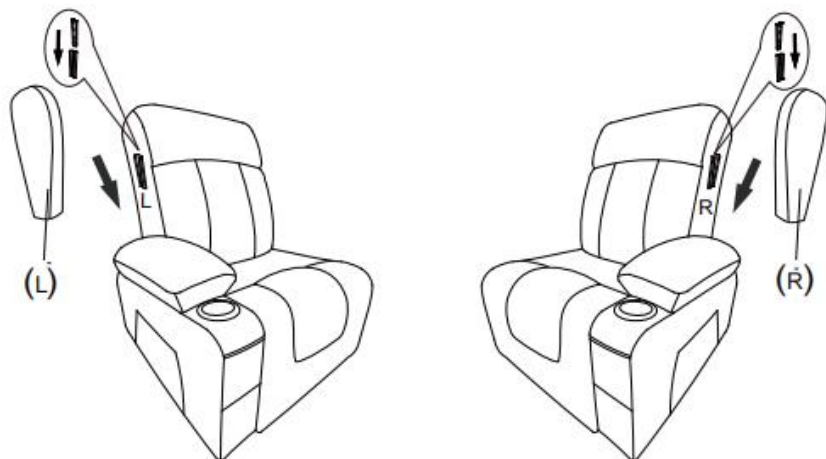

STEP 11 :Hang the middle position on the pendant slots on the left and right positions, and the three chairs can be connected together.

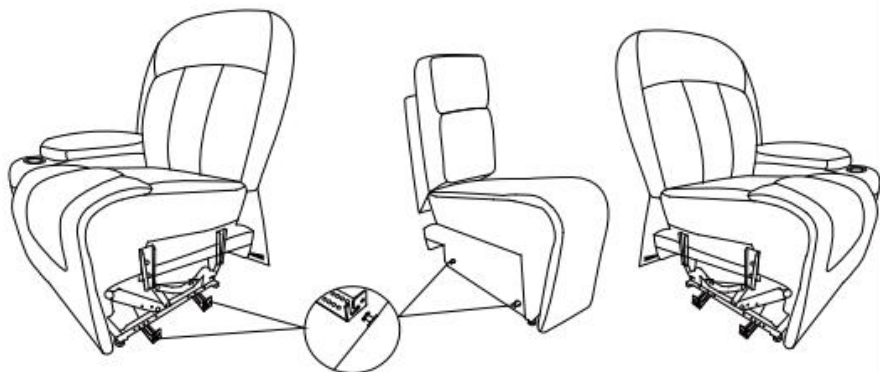

STEP 12 :Connect the power cord (X) to the power adapter (I),finally,stick up the Velcro below.Connect the power cord to the middle seat.

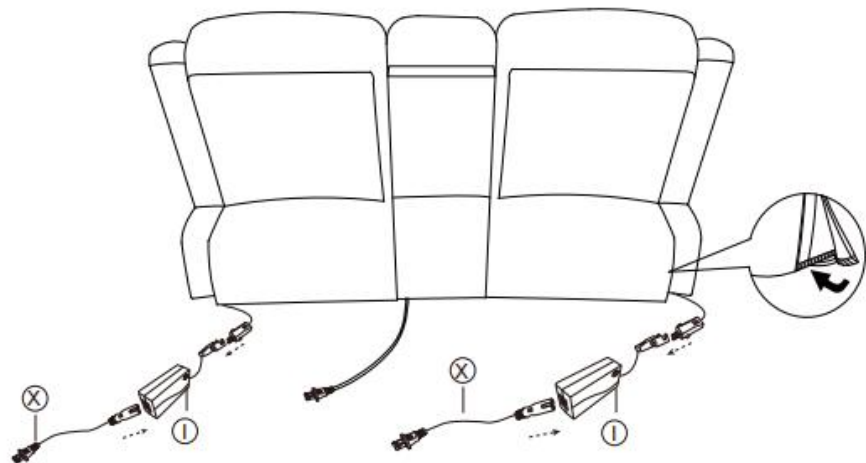

Congratulations! You've assembled
Your Sofa!

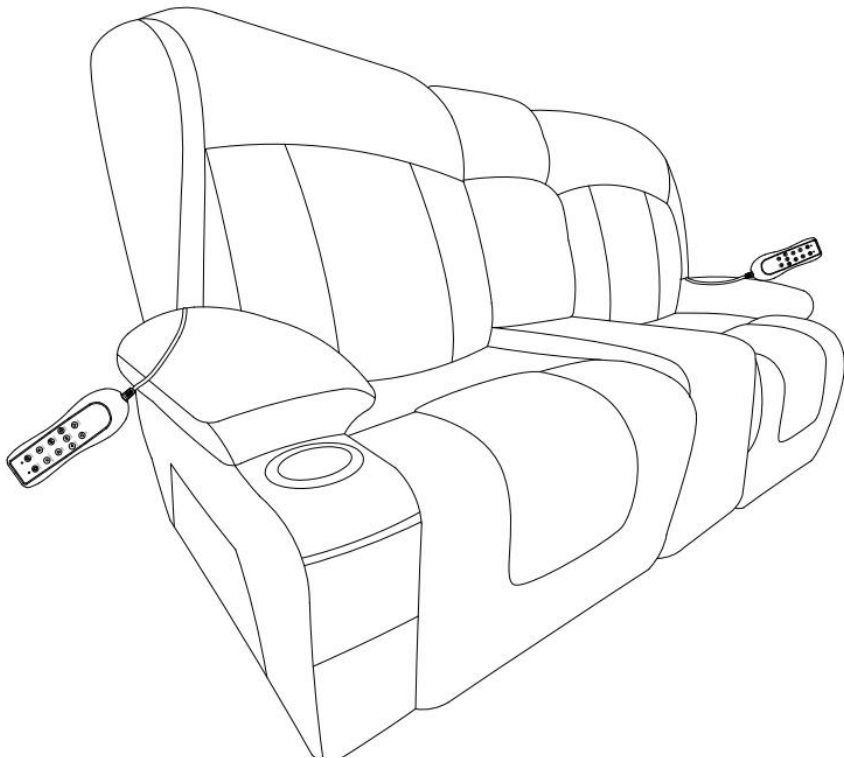

Note:

Since the backrest is packed in compression, after the product is installed, you need to tap and adjust the backrest which can help restore fullness. After two days, you will get a Overstuffed Recliners as picture shows.

OPERATING INSTRUCTION

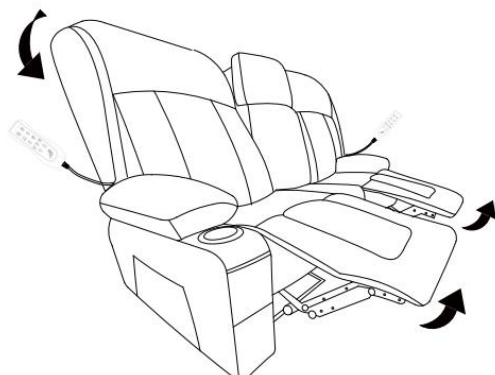

Press the switch to open the sofa

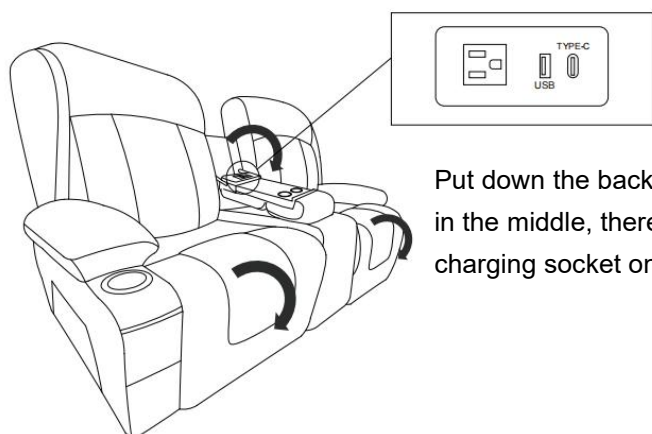

Put down the backrest in the middle, there is a charging socket on it.

Press the switch to lift the sofa

FUNCTION OF THE REMOTE CONTROL

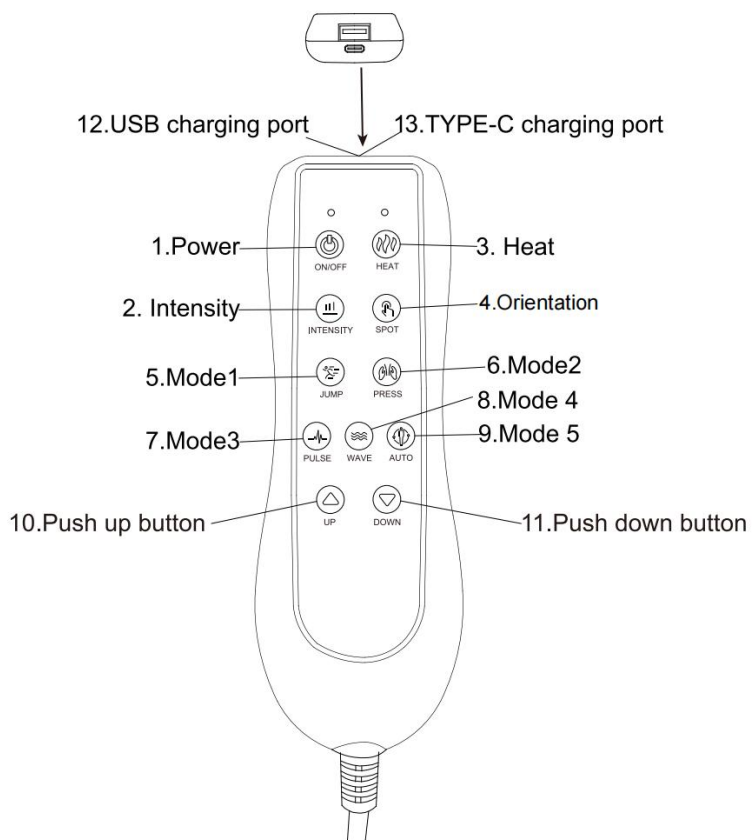

Product features

1. 4 Position, 8 Vibration motor
2. 5 motor vibration modes
3. Add hot spots to one part
4. The default shutdown duration is 15 minutes
5. 1 way electric push rod
6. USB/TYPE-C charging function

Function details

1. Switch on and off (Boot vibration full on (default strong/automatic mode))

2. Switch point by vibration intensity

3. Click heating switch circulation

4. Vibration positioning key

By default, the vibration is fully on when the machine is started

Sequence switch motor vibration in individual parts (back vibration → waist vibration → Leg vibration → Neck vibration → full open) cycle

5. Mode 1 (Skip mode)

6. Mode 2 (Press vibration mode)

7. Mode 3 (Pulse vibration mode)

8. Mode 4 (Wave vibration mode)

9. Mode 5 (Conventional vibration mode)

10. Long press the push rod upward

11. Long press the putter down

12. USB charging port

13. TYPE-C charging port

WARNINGS

- Delikatnie usiądź na krześle. Aby uniknąć przewrócenia, nie rzucaj się na nie. Powoli rozłóż krzesło do pozycji leżącej, upewniając się, że w pobliżu nie ma dzieci ani zwierząt. Nie pozwalaj dzieciom bawić się na krześle ani w jego pobliżu, zwłaszcza gdy jest ono otwarte.
- Przed wyjściem z fotela należy go całkowicie zamknąć.
- Nigdy nie siadaj na podnóżku, gdy jest on otwarty, nawet jeżeli siedzi na nim dziecko.
- Aby wyeliminować ryzyko przewrócenia się, nie należy siadać na podłokietnikach ani na podnóżkach krzesła.
- Krzesło jest przeznaczone do użytku przez jedną osobę dorosłą na raz.
- Prosimy, aby osoby z następującymi schorzeniami nie korzystały z tej sofy: osoby z poważnymi objawami choroby serca, nadciśnieniem, zakrzepicą mózgową oraz inne osoby wrażliwe na ciepło lub całkowicie niewrażliwe na ciepło, osoby o kruchych kościach lub mające problemy z podparciem talii, kobiety w ciąży, dzieci i inne osoby, u których stwierdzono, że nie nadają się do korzystania z tego produktu zgodnie z zaleceniami lekarza.
- Aby w pełni rozłożyć sofę, należy ją dobrze rozłożyć – należy ustawić ją w odległości co najmniej 19 cali od ściany lub innej przeszkody.
- Produkt nie może mieć kontaktu z wodą, ogniem itp. Produkt nie może mieć również kontaktu z ostrymi przedmiotami (nożami, gwoździemi itp.).

MAINTENANCE MANUAL INSTRUCTIONS

- Aby uniknąć upadku, należy przenosić sofę ostrożnie.
- Jeśli na fotelu znajdują się zabrudzenia lub plamy, spryskaj sofę środkiem czyszczącym przeznaczonym do sof, a następnie zetrzyj brud gąbką lub ściereczką. Nie używaj wody, wody z mydłem ani środka czyszczącego do woskowanych drewnianych powierzchni. Wycieraj sofę ostrożnie i delikatnie.

- Nie należy umieszczać sofy w miejscu narażonym na bezpośrednie działanie promieni słonecznych ani bezpośrednio przed klimatyzatorem, gdyż może to spowodować wyblaknięcie tapicerki i jej kruchość.

HOW TO DISASSEMBLE

Please find a strong tool to prod the small piece of metal grooves, then the backrest will be pulled out. The tool is not included.

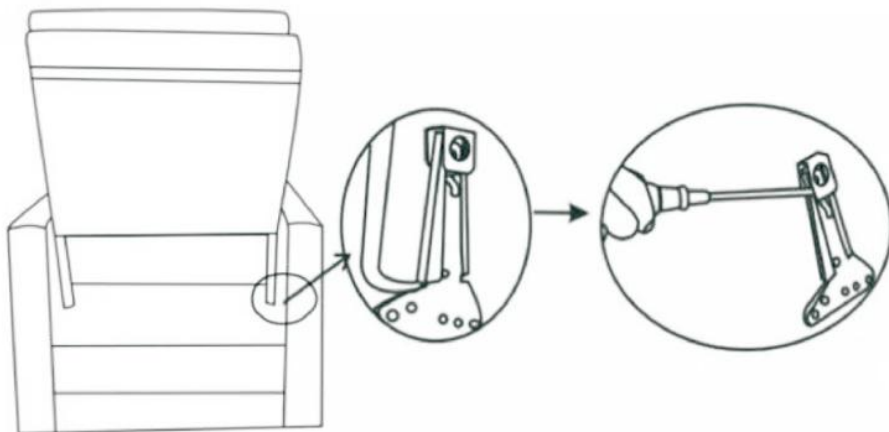

PRODUCT PARAMETER

Model	A1503-2DLR
Ocena(y)	100 V-240 V 50/60 Hz 1,5 A
Kolor główny	Brązowy
Nośność pojedynczego siedzenia	330 funtów
Wymiary produktu (gł.*szer.*wys.)	965*1830*1080 mm
Waga netto	75 kg

* Produkty mogą podlegać zmianom dotyczącym specyfikacji, wyglądu i konstrukcji bez wcześniejszego powiadomienia.

Producent: Shanghaimuxinmuyeyouxiangongsi

Adres: Shuangchenglu 803nong11hao1602A-1609shi, baoshanqu, szanghaj 200000 CN.

Importowane do Australii: SIHAO PTY LTD. 1 ROKEVA
STREETEASTWOOD NSW 2122 Australia

Importowane do USA: Sanven Technology Ltd. Suite 250, 9166 Anaheim
Place, Rancho Cucamonga, CA 91730

EC	REP
-----------	------------

E-CrossStu GmbH
Mainzer Landstr.69, 60329 Frankfurt am Main.

UK	REP
-----------	------------

YH CONSULTING LIMITED.
C/O YH Consulting Limited Office 147, Centurion
House, London Road, Staines-upon-Thames, Surrey,
TW18 4AX



VEVOR

Affordable. Reliable. Home Improvement.

STOFFEN LOVESEAT RELAXFAUTEUIL

MODEL: A1503-2DLR

Video met installatie-instructies voor een stoffen loveseat :

d2qc09r11qfuof.cloudfront.net/product/DDBYSRSFDDKDAD7LT001/fabric+Loveseat+Recliner+Installatie+Instructie+Video.mp4



VEVOR



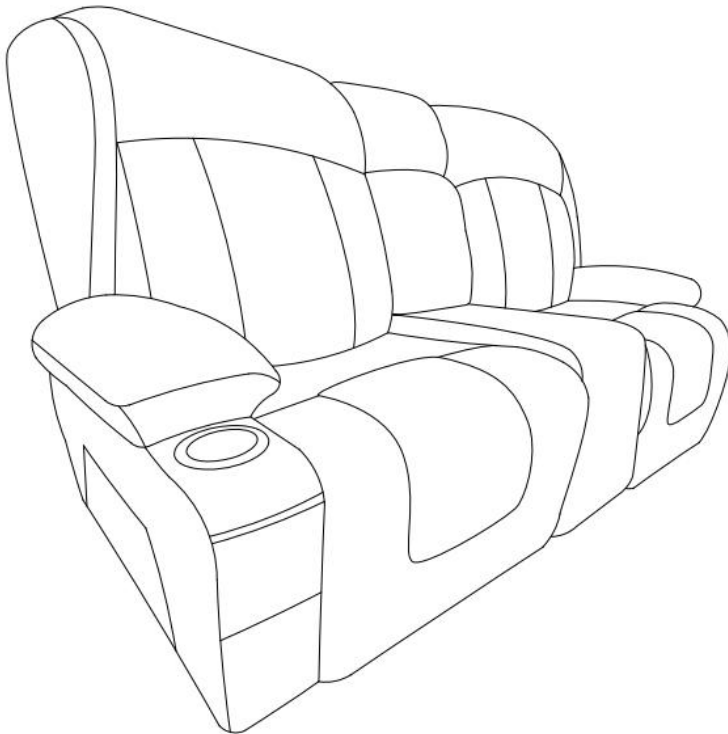

Affordable. Reliable. Home Improvement.

Fabric Loveseat
Recliner

MODEL: A1503-2DLR



Dit is de originele handleiding. Lees alle instructies zorgvuldig door voordat u het product gebruikt. VEVOR behoudt zich het recht voor om de gebruiksaanwijzing duidelijk te interpreteren. Het uiterlijk van het product is afhankelijk van het product dat u hebt ontvangen. Neemt u het ons niet kwalijk dat we u niet meer op de hoogte stellen van eventuele technologische of software-updates voor ons product.

	<p>Waarschuwing: om het risico op letsel te verminderen, dient de gebruiker de gebruiksaanwijzing zorgvuldig te lezen.</p>
	<p>Compliance is een C E- beveiligingscertificering.</p>
	<p>CORRECTE VERWIJDERING</p> <p>Dit product valt onder de bepalingen van de Europese Richtlijn 2012/19/EG. Het symbool met een doorgekruiste vuilnisbak geeft aan dat het product in de Europese Unie gescheiden afval moet worden ingezameld. Dit geldt voor het product en alle accessoires die met dit symbool zijn gemarkeerd. Producten die als zodanig zijn gemarkeerd, mogen niet met het normale huisvuil worden weggegooid, maar moeten worden ingeleverd bij een inzamelpunt voor de recycling van elektrische en elektronische apparaten .</p>
	<p>Waarschuwing - Alleen voor gebruik binnenshuis</p>
	<p>FCC-informatie:</p> <p>LET OP: Wijzigingen of aanpassingen die niet uitdrukkelijk zijn goedgekeurd door de partij die verantwoordelijk is voor de naleving, kunnen de bevoegdheid van de gebruiker om het apparaat te bedienen ongeldig maken!</p> <p>Dit apparaat voldoet aan Deel 15 van de FCC-regels. Gebruik is onderworpen aan de volgende twee voorwaarden:</p> <ol style="list-style-type: none"> 1) Dit product kan schadelijke interferentie veroorzaken. 2) Dit product moet alle ontvangen interferentie accepteren, inclusief interferentie die een ongewenste werking kan veroorzaken. <p>WAARSCHUWING: Wijzigingen of aanpassingen aan dit product die niet uitdrukkelijk zijn goedgekeurd door de partij die verantwoordelijk is voor de naleving, kunnen de bevoegdheid van de gebruiker om het product te bedienen ongeldig maken.</p> <p>Let op: Dit product is getest en voldoet aan de limieten voor een digitaal apparaat van klasse B, conform Deel 15 van de FCC-regels. Deze limieten zijn bedoeld om een redelijke bescherming te bieden</p>

tegen schadelijke interferentie in een woonomgeving.

Dit product genereert, gebruikt en kan radiofrequentie-energie uitstralen. Indien niet geïnstalleerd en gebruikt volgens de instructies, kan het schadelijke interferentie in radiocommunicatie veroorzaken. Er is echter geen garantie dat er in een bepaalde installatie geen interferentie zal optreden. Als dit product schadelijke interferentie veroorzaakt in radio- of televisieontvangst, wat kan worden vastgesteld door het product uit en weer in te schakelen, wordt de gebruiker aangeraden de interferentie te verhelpen door een of meer van de volgende maatregelen te nemen.

- De ontvangstantenne opnieuw richten of verplaatsen.
- Vergroot de afstand tussen het product en de ontvanger.
- Sluit het product aan op een stopcontact van een ander circuit dan dat waarop de ontvanger is aangesloten.
- Raadpleeg de dealer of een ervaren radio-/tv-technicus voor hulp.

SAFETY INSTRUCTIONS

WAARSCHUWING:

Lees dit materiaal voordat u dit product gebruikt. Het niet naleven hiervan kan ernstig letsel tot gevolg hebben.

Voorzorgsmaatregelen voor montage

1. Monteer uitsluitend volgens deze instructies. Onjuiste montage kan gevaarlijk zijn.
2. Draag tijdens de montage een ANSI-goedgekeurde veiligheidsbril en stevige werkhandschoenen.
3. Houd de verzamelplaats schoon en goed verlicht.
4. Houd omstanders tijdens de montage uit de buurt.
5. Kom niet in actie als u moe bent of onder invloed van alcohol, drugs of medicijnen.
6. U kunt de stoel ook zelf in elkaar zetten, maar het is nog makkelijker als u daarbij iemand anders inschakelt.
7. De producteigenschappen gelden uitsluitend voor correct en volledig gemonteerde producten.
8. F abric Loveseat Recliner veilig kan dragen .
9. Controleer voordat u begint of er onderdelen in het pakket ontbreken. Mochten er problemen zijn, stuur ons dan gerust een e-mail en we helpen u zo snel mogelijk verder.
10. Raadpleeg voor meer informatie over de onderdelen die op de volgende pagina's worden vermeld het montageschema in deze handleiding. Pak alle onderdelen uit en scheid ze van elkaar op een schone werkplek.

Gebruik voorzorgsmaatregelen

1. Alleen gebruiken zoals bedoeld.
2. Controleer het product voor elk gebruik. Niet gebruiken als er onderdelen loszitten of beschadigd zijn.

BEWAAR DEZE HANDLEIDING

PARTS LIST

 Seat cushion (A)*1	 Seat cushion (A)*1	 L Back (B)*1	 R Back (B)*1
 Middle Back (B)*1	 L Seat frame (C)*1	 R Seat frame (C)*1	 Middle Seat (C)*1
 F (L) Armrest bag (F)*1	 F (R) Armrest bag (F)*1	 L*1 Back ear	 R*1 Back ear
 Massage remote control board (G)*2	 Motor power supply (I)*2	 Power line (X)*2	 Glove *2
 Cup holder *2	 Screw (N)*8	 Spanner (O)*1	 Connector *4
 Screw (S)*4	 Spacer (T)*4		
 Under the frame			

ASSEMBLY STEP

STEP 1: Open the compression bag and remove the soft bag.

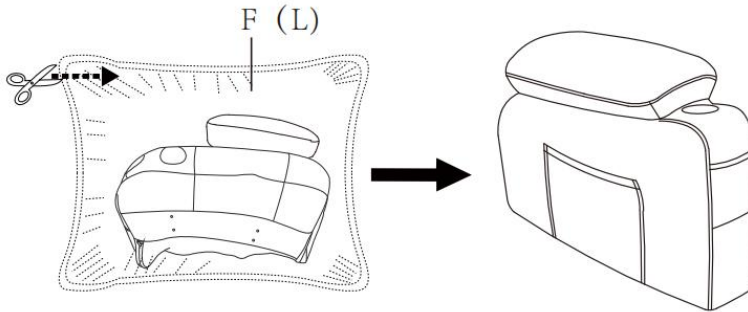

STEP 2: Repeat Step 1.

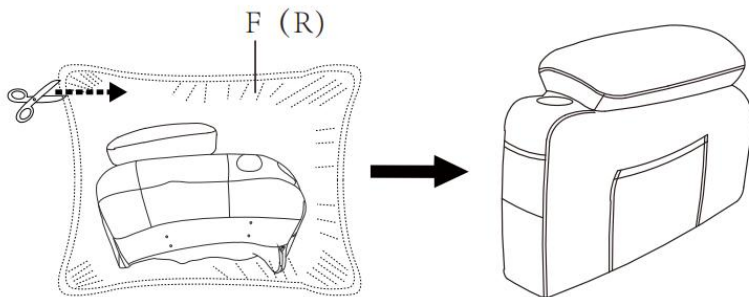

STEP 3: Fix the connector to the inside of the armrest with M6x16mm screws, paying attention to the direction of fixing the connector.

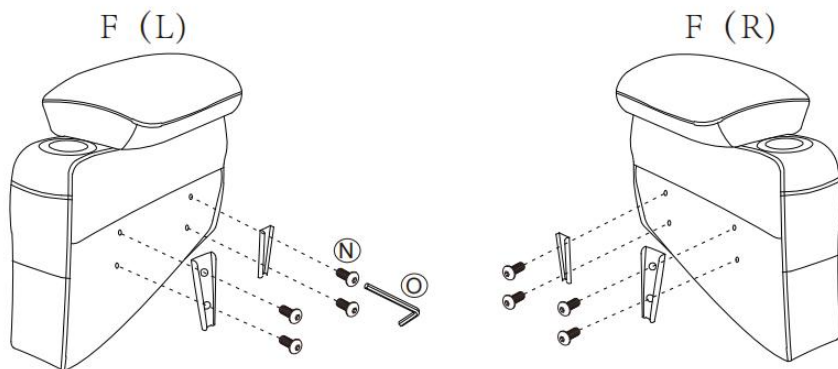

STEP 4: Fix the screws on both sides of the middle seat.

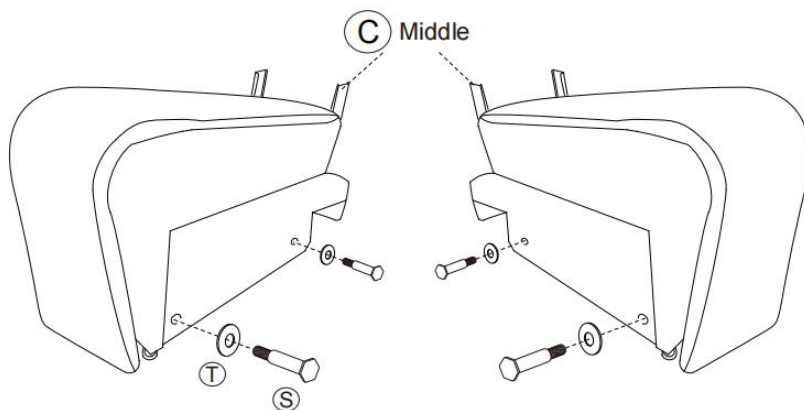

STEP 5:Place the cup holder into the groove.

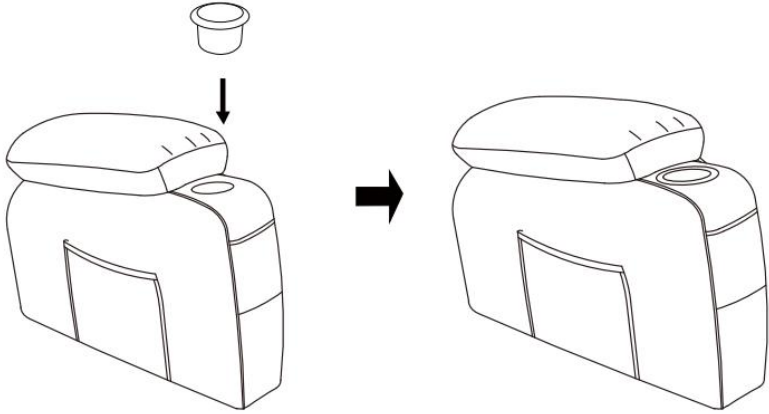

STEP 6:Insert arms so that they can fit into the seat, you will hear a “click” when they are engaged.

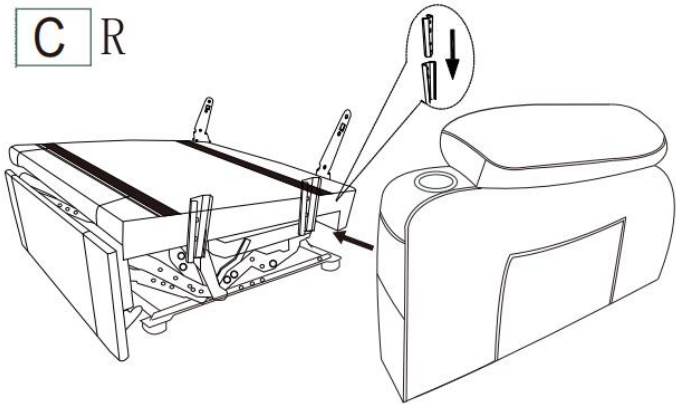

STEP7: Repeat Step 6

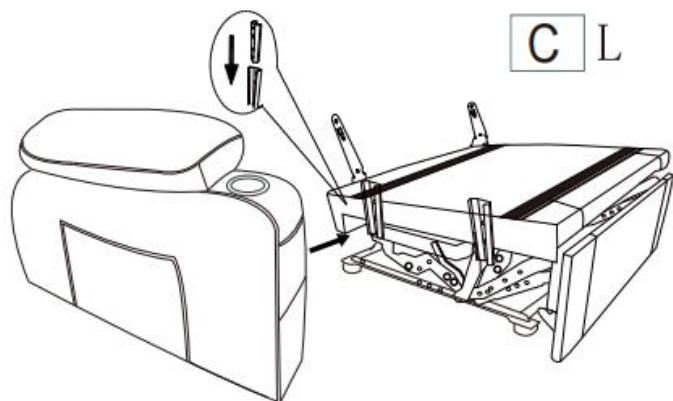

STEP8: Open seat bag A, stick the Velcro on the footboard, and stick the Velcro on the seat bag.

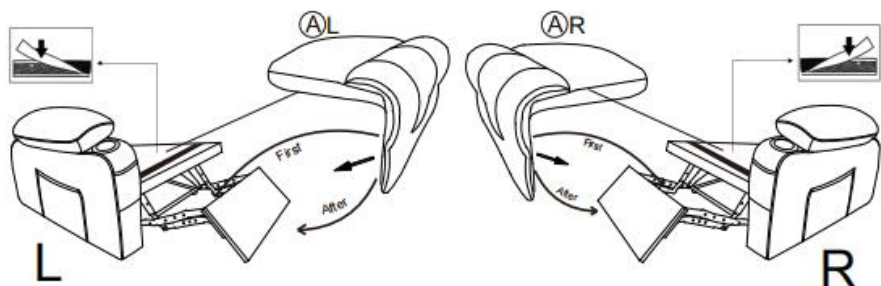

Note: First, power on, turn on the footrest, and then install the seat cushion

STEP 9: Plug the back pad into the seat frame, then connect the massager lines: white with white, red with red, black with the power lines, connect the massage line with the handcontroller.

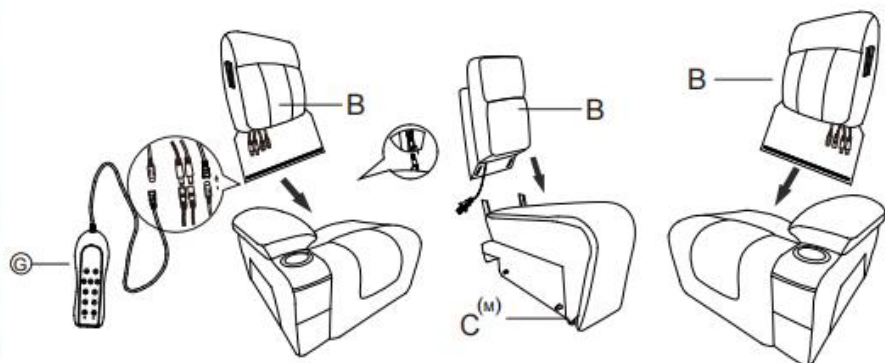

STEP 10: Install the back ears on both sides of the backrest.

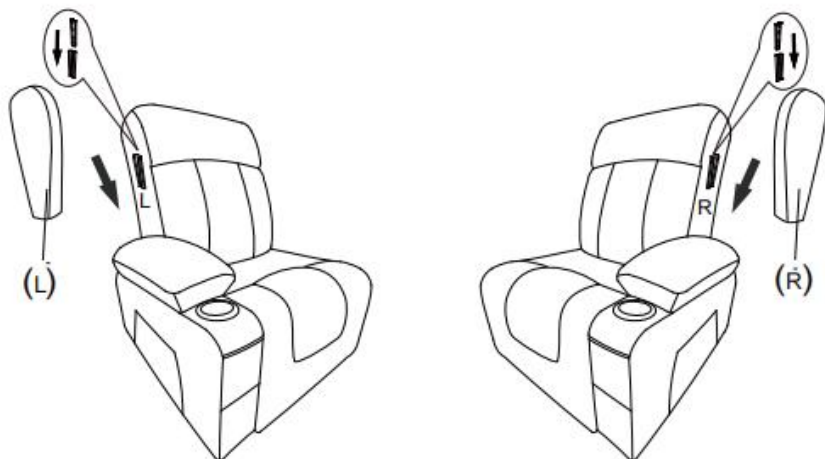

STEP 11 :Hang the middle position on the pendant slots on the left and right positions, and the three chairs can be connected together.

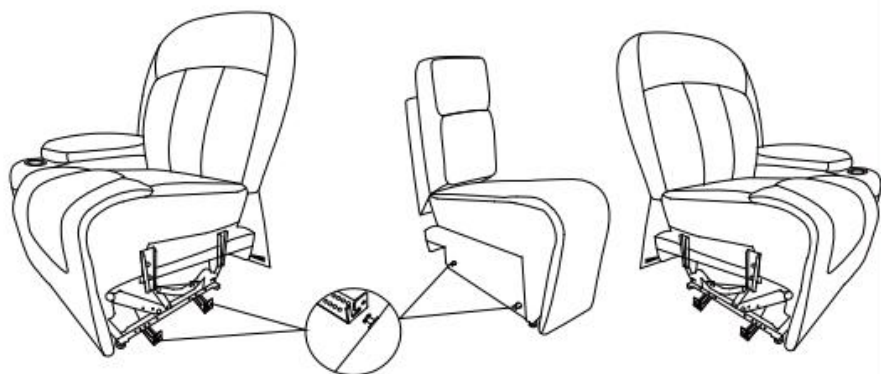

STEP 12 :Connect the power cord (X) to the power adapter (I),finally,stick up the Velcro below.Connect the power cord to the middle seat.

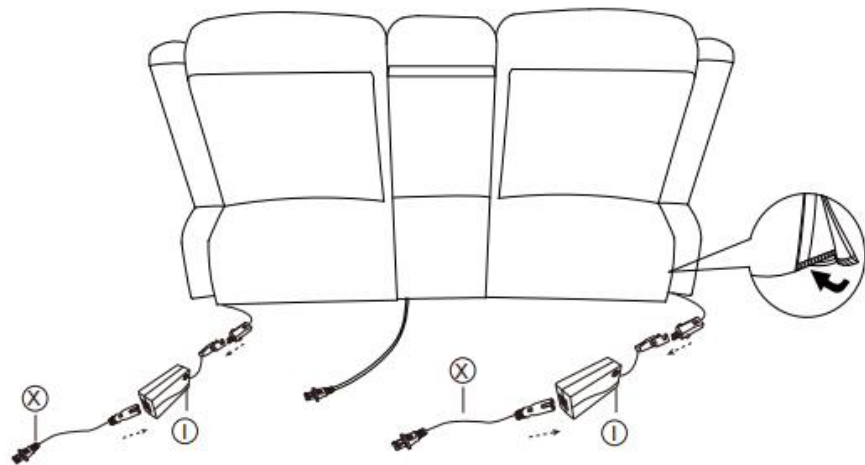

Congratulations! You've assembled
Your Sofa!

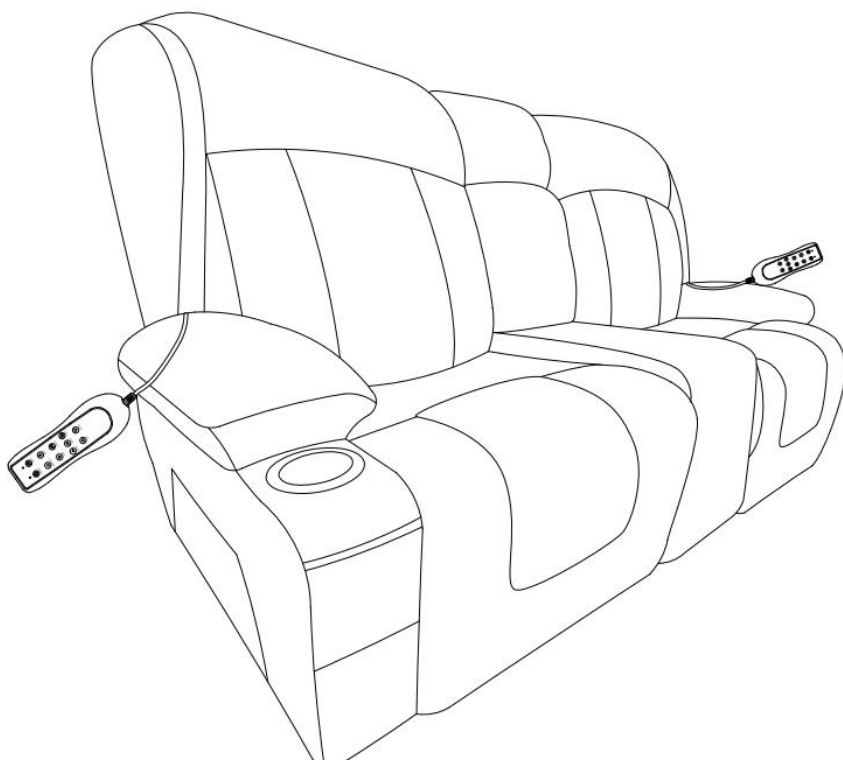

Note:

Since the backrest is packed in compression, after the product is installed, you need to tap and adjust the backrest which can help restore fullness. After two days, you will get a Overstuffed Recliners as picture shows.

OPERATING INSTRUCTION

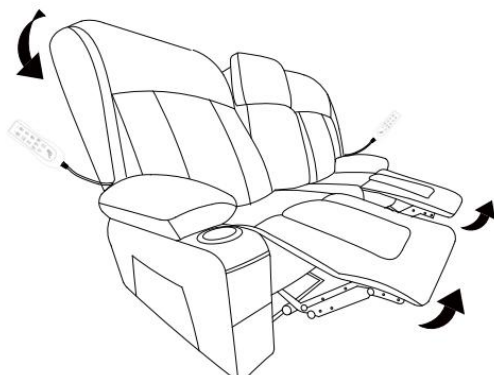

Press the switch to open the sofa

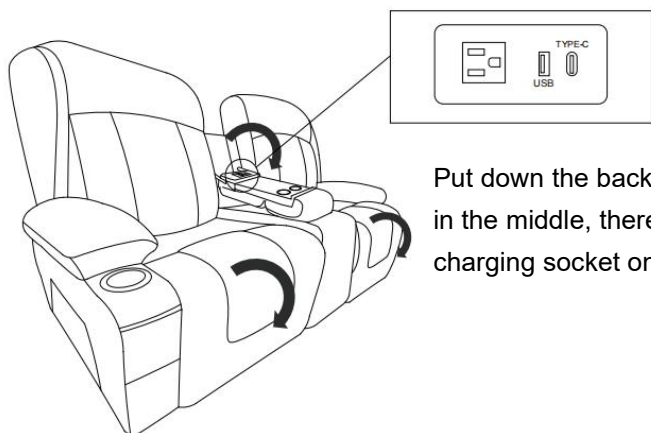

Put down the backrest in the middle, there is a charging socket on it.

Press the switch to lift the sofa

FUNCTION OF THE REMOTE CONTROL

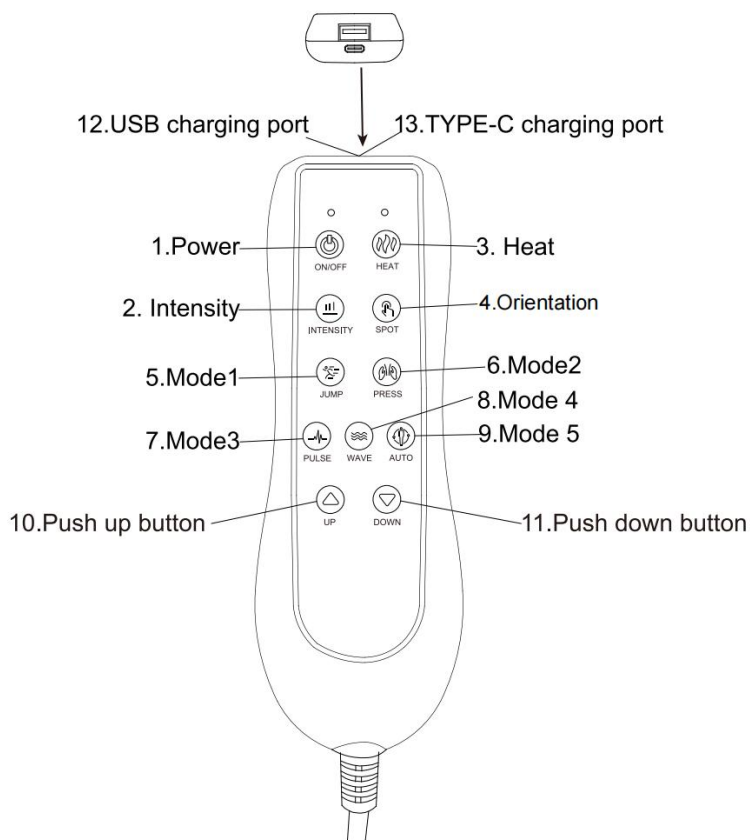

Product features

1. 4 Position, 8 Vibration motor
2. 5 motor vibration modes
3. Add hot spots to one part
4. The default shutdown duration is 15 minutes
5. 1 way electric push rod
6. USB/TYPE-C charging function

Function details

1. Switch on and off (Boot vibration full on (default strong/automatic mode))

2. Switch point by vibration intensity

3. Click heating switch circulation

4. Vibration positioning key

By default, the vibration is fully on when the machine is started

Sequence switch motor vibration in individual parts (back vibration → waist vibration → Leg vibration → Neck vibration → full open) cycle

5. Mode 1 (Skip mode)

6. Mode 2 (Press vibration mode)

7. Mode 3 (Pulse vibration mode)

8. Mode 4 (Wave vibration mode)

9. Mode 5 (Conventional vibration mode)

10. Long press the push rod upward

11. Long press the putter down

12. USB charging port

13. TYPE-C charging port

WARNINGS

- Ga rustig in de stoel zitten. Om te voorkomen dat u omvalt, moet u zich niet in de stoel laten vallen. Beweeg de stoel langzaam naar de ligpositie en zorg ervoor dat er geen kinderen of huisdieren in de buurt zijn. Laat kinderen niet op of rond de stoel spelen, vooral niet wanneer deze open staat.
- Klap de relaxfauteuil helemaal dicht voordat u eruit stapt.
- Ga nooit op de voetensteun zitten als deze uitgeklappt is, ook niet als het een kind betreft.
- Om het risico op kantelen te voorkomen, mag u niet op de armleningen of voetensteunen van de stoel gaan zitten.
- Deze stoel is ontworpen voor gebruik door maximaal 1 volwassene.
- Mensen met de volgende aandoeningen mogen deze bank niet gebruiken: Personen met ernstige symptomen van hartkwalen, hoge bloeddruk, cerebrale trombose en anderen die gevoelig zijn voor warmte of er helemaal niet gevoelig voor zijn, personen met broze botten of problemen met de ondersteuning van de taille, zwangere vrouwen, kinderen en anderen waarbij is vastgesteld dat zij dit product niet mogen gebruiken, onder begeleiding van een arts.
- Om de bank volledig te kunnen laten kantelen, moet u ervoor zorgen dat de bank minimaal 48 cm van de muur of een ander obstakel af staat.
- Het product mag niet in aanraking komen met water, vuur, enz. Het product mag ook niet in aanraking komen met scherpe voorwerpen (messen, spijkers, enz.)

MAINTENANCE MANUAL INSTRUCTIONS

- Om te voorkomen dat u de bank laat vallen, moet u hem voorzichtig dragen.
- Als u vuil en/of vlekken op de stoel vindt, spuit de bank dan in met een speciale reiniger voor banken en veeg het vuil weg met een spons of doek. Gebruik geen water, zeepsop of schoonmaakmiddel op gewaxte

houten oppervlakken. Veeg de bank voorzichtig en voorzichtig af.

- Zet de bank niet in een ruimte met direct zonlicht en zet de bank niet direct voor een airconditioner. Hierdoor zal de bekleding vervagen en broos worden.

HOW TO DISASSEMBLE

Please find a strong tool to prod the small piece of metal grooves, then the backrest will be pulled out. The tool is not included.

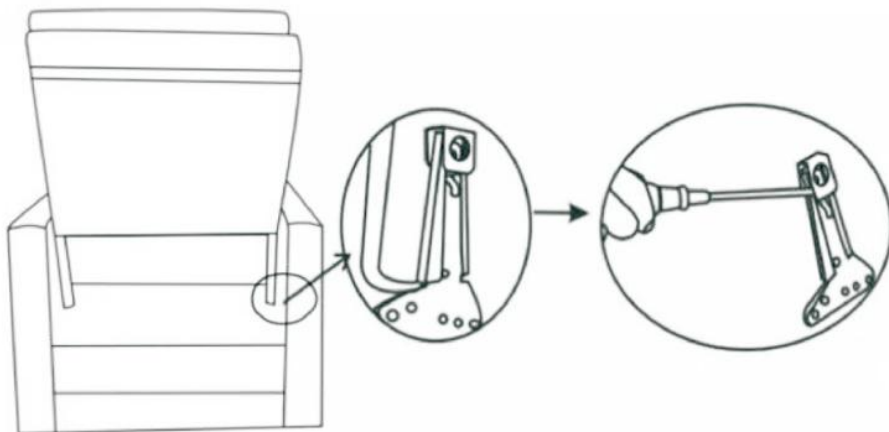

PRODUCT PARAMETER

Model	A1503-2DLR
Beoordeling(en)	100V-240V 50/60Hz 1,5A
Hoofdkleur	Bruin
Draagvermogen van één zitplaats	330 pond
Productafmetingen (D*B*H)	965*1830*1080mm
Nettogewicht	75 kg

* Productspecificaties, zoals het uiterlijk en het ontwerp, kunnen zonder voorafgaande kennisgeving worden gewijzigd.

Fabrikant: Shanghai muxinmuyeyouxiangongsi

Adres: Shuangchenglu 803nong11hao1602A-1609shi, baoshanqu, shanghai 200000 CN.

Geïmporteerd naar AUS: SIHAO PTY LTD. 1 ROKEVA STREET EASTWOOD NSW 2122 Australië

Geïmporteerd naar de VS: Sanven Technology Ltd. Suite 250, 9166 Anaheim Place, Rancho Cucamonga, CA 91730

EC	REP
-----------	------------

E-CrossStu GmbH
Mainzer Landstr.69, 60329 Frankfurt am Main.

UK	REP
-----------	------------

YH CONSULTING LIMITED.
C/O YH Consulting Limited Office 147, Centurion House, London Road, Staines-upon-Thames, Surrey, TW18 4AX



VEVOR

Affordable. Reliable. Home Improvement.

SILLÓN RECLINABLE DE TELA LOVESEAT

MODELO: A1503-2DLR

Video con instrucciones de instalación del sillón reclinable de tela :

d2qc09rl1qfuof.cloudfront.net/product/DDBYSRSFDDKDAD7LT001/Tela+Loveseat+Reclinable+Instrucciones+de+Instalación+Video.mp4



VEVOR



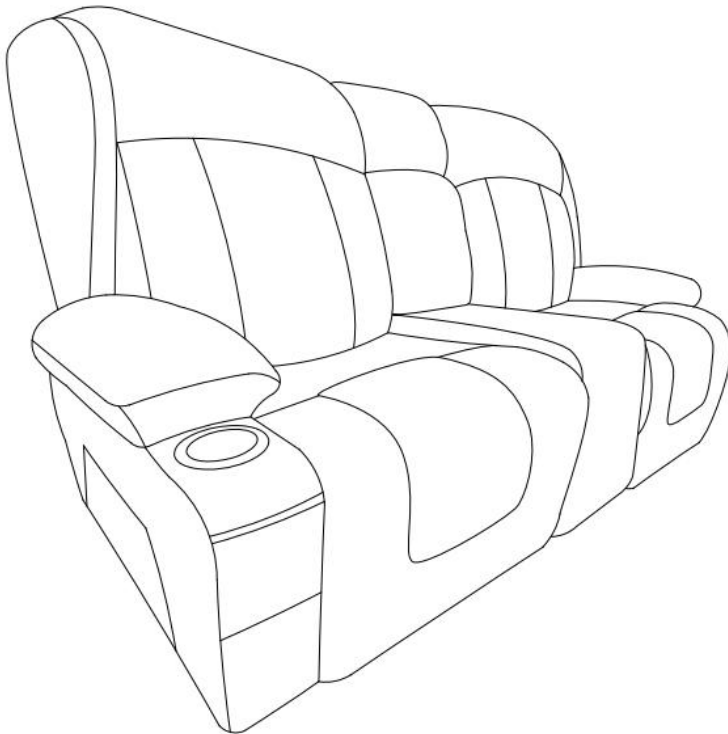

Affordable. Reliable. Home Improvement.

Fabric Loveseat
Recliner

MODELO: A1503-2DLR



Estas son las instrucciones originales; lea atentamente todas las instrucciones del manual antes de utilizarlo. VEVOR se reserva el derecho de interpretar su manual de usuario. La apariencia del producto dependerá del producto que haya recibido. Le rogamos que nos disculpe si no le informamos de nuevo si hay actualizaciones tecnológicas o de software en nuestro producto.

	<p>Advertencia: Para reducir el riesgo de lesiones, el usuario debe leer atentamente el manual de instrucciones.</p>
	<p>Compliance es una certificación de seguridad CE .</p>
	<p>ELIMINACIÓN CORRECTA</p> <p>Este producto está sujeto a la Directiva Europea 2012/19/CE. El símbolo de un contenedor de basura tachado indica que el producto requiere la recogida selectiva de residuos en la Unión Europea. Esto aplica al producto y a todos los accesorios marcados con este símbolo. Los productos marcados con este símbolo no pueden desecharse con la basura doméstica normal, sino que deben llevarse a un punto de recogida para el reciclaje de aparatos eléctricos y electrónicos .</p>
	<p>Advertencia: solo para uso en interiores</p>
	<p>Información de la FCC:</p> <p>PRECAUCIÓN: ¡Los cambios o modificaciones no aprobados expresamente por la parte responsable del cumplimiento podrían anular la autoridad del usuario para operar el equipo!</p> <p>Este dispositivo cumple con la Parte 15 de las Normas de la FCC. Su funcionamiento está sujeto a las dos condiciones siguientes:</p> <ol style="list-style-type: none"> 1) Este producto puede causar interferencias dañinas. 2) Este producto debe aceptar cualquier interferencia recibida, incluida aquella que pueda provocar un funcionamiento no deseado. <p>ADVERTENCIA: Los cambios o modificaciones a este producto no aprobados expresamente por la parte responsable del cumplimiento podrían anular la autoridad del usuario para operar el producto.</p> <p>Nota: Este producto ha sido probado y se ha comprobado que cumple con los límites para un dispositivo digital de Clase B según la Parte 15 de las Normas de la FCC. Estos límites están diseñados para brindar protección razonable contra interferencias dañinas en una instalación residencial.</p>

Este producto genera, utiliza y puede radiar energía de radiofrecuencia. Si no se instala y utiliza según las instrucciones, puede causar interferencias perjudiciales en las comunicaciones por radio. Sin embargo, no se garantiza que no se produzcan interferencias en una instalación específica. Si este producto causa interferencias perjudiciales en la recepción de radio o televisión, lo cual puede determinarse encendiéndolo y apagándolo, se recomienda al usuario que intente corregir la interferencia mediante una o más de las siguientes medidas.

- Reorientar o reubicar la antena receptora.
- Aumentar la distancia entre el producto y el receptor.
- Conecte el producto a una toma de corriente de un circuito diferente a aquel al que está conectado el receptor.
- Consulte al distribuidor o a un técnico de radio/TV experimentado para obtener ayuda.

SAFETY INSTRUCTIONS

ADVERTENCIA:

Lea este material antes de usar este producto. De lo contrario, podría sufrir lesiones graves.

Precauciones de montaje

1. Ensamble únicamente según estas instrucciones. Un montaje incorrecto puede causar riesgos.
2. Use gafas de seguridad aprobadas por ANSI y guantes de trabajo resistentes durante el montaje.
3. Mantenga el área de reunión limpia y bien iluminada.
4. Mantenga a los transeúntes fuera del área durante el montaje.
5. No realice el montaje si está cansado o bajo la influencia del alcohol, drogas o medicamentos.
6. Además, si bien es posible montar la silla por tu cuenta, contar con la ayuda de una segunda persona lo hace aún más fácil.
7. Las capacidades del producto se aplican únicamente a productos ensamblados correcta y completamente.
8. Ensamble sobre una superficie plana, nivelada, dura y lisa capaz de soportar de manera segura el sillón reclinable de tela Loveseat.
9. Antes de comenzar, verifique si falta alguna pieza en el paquete. Si surge algún problema, no dude en enviarnos un correo electrónico y le ayudaremos lo antes posible.
10. Para obtener más información sobre las piezas que se enumeran en las páginas siguientes, consulte el diagrama de montaje de este manual. Desembale y separe todas las piezas en un área de trabajo limpia.

Precauciones de uso

1. Úselo únicamente según lo previsto.
2. Inspeccione antes de cada uso; no lo utilice si las piezas están sueltas o dañadas.

GUARDE ESTE MANUAL

PARTS LIST

 Seat cushion (A)*1	 Seat cushion (A)*1	 L Back (B)*1	 R Back (B)*1
 Middle Back (B)*1	 L Seat frame (C)*1	 R Seat frame (C)*1	 Middle Seat (C)*1
 F (L) Armrest bag (F)*1	 F (R) Armrest bag (F)*1	 L*1 Back ear	 R*1 Back ear
 Massage remote control board (G)*2	 Motor power supply (I)*2	 Power line (X)*2	 Glove *2
 Cup holder *2	 Screw (N)*8	 Spanner (O)*1	 Connector *4
 Screw (S)*4	 Spacer (T)*4		
 Under the frame			

ASSEMBLY STEP

STEP 1: Open the compression bag and remove the soft bag.

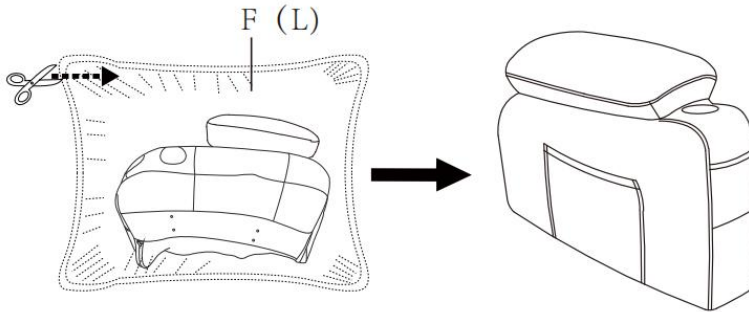

STEP 2: Repeat Step 1.

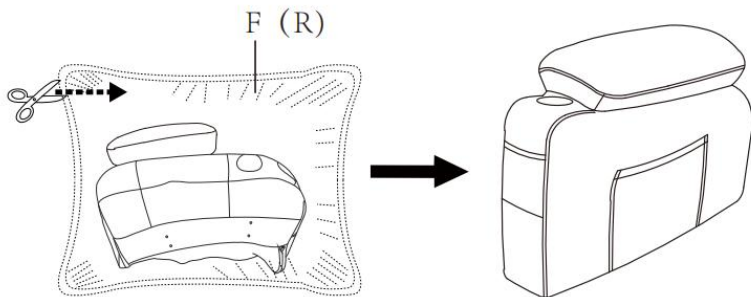

STEP 3: Fix the connector to the inside of the armrest with M6x16mm screws, paying attention to the direction of fixing the connector.

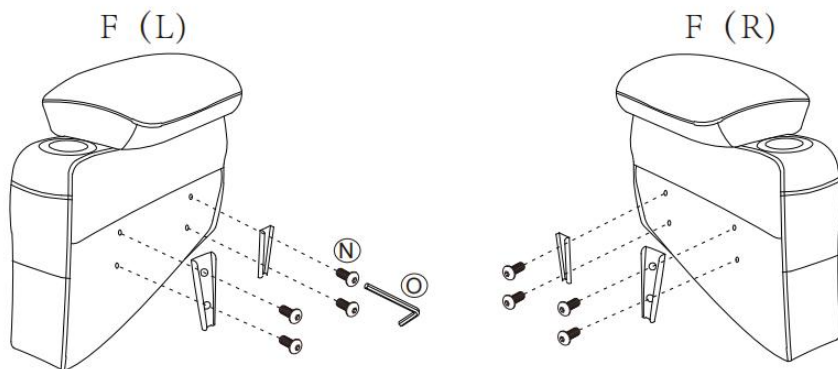

STEP 4: Fix the screws on both sides of the middle seat.

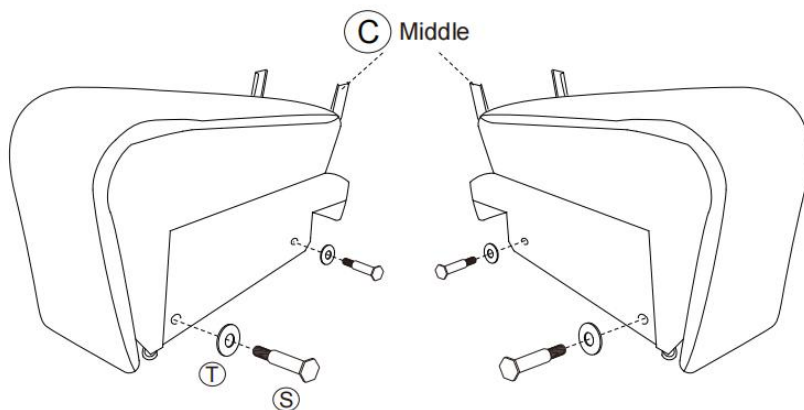

STEP 5:Place the cup holder into the groove.

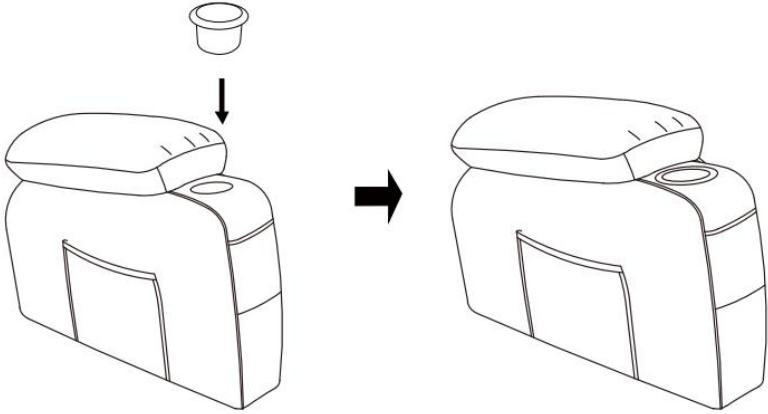

STEP 6:Insert arms so that they can fit into the seat, you will hear a “click” when they are engaged.

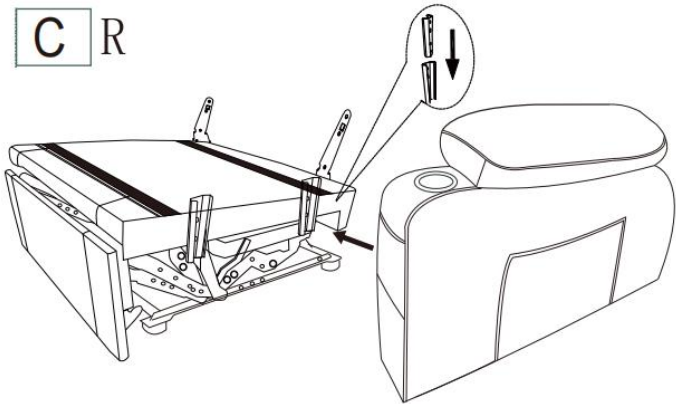

STEP7: Repeat Step 6

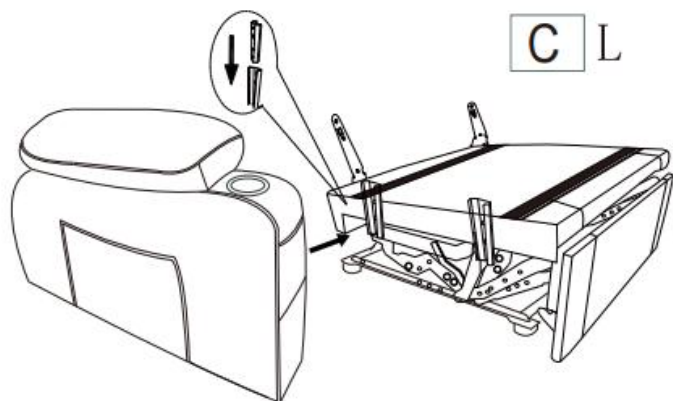

STEP8: Open seat bag A, stick the Velcro on the footboard, and stick the Velcro on the seat bag.

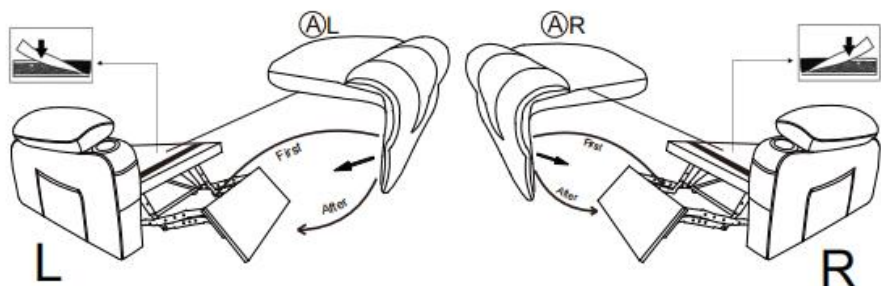

Note: First, power on, turn on the footrest, and then install the seat cushion

STEP 9: Plug the back pad into the seat frame, then connect the massager lines: white with white, red with red, black with the power lines, connect the massage line with the handcontroller.

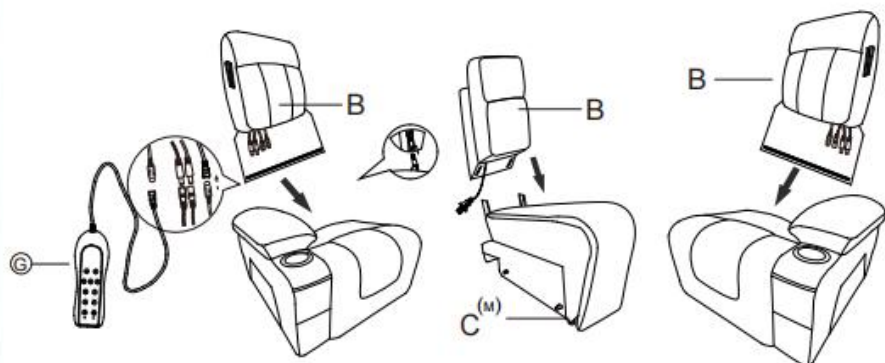

STEP 10: Install the back ears on both sides of the backrest.

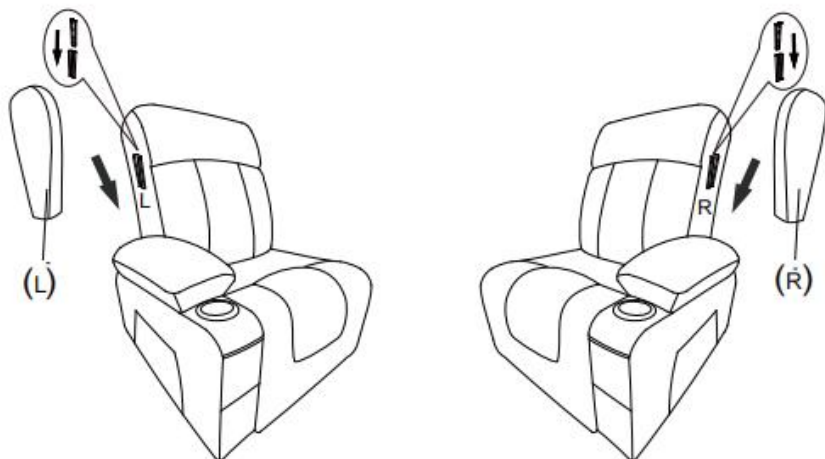

STEP 11 :Hang the middle position on the pendant slots on the left and right positions, and the three chairs can be connected together.

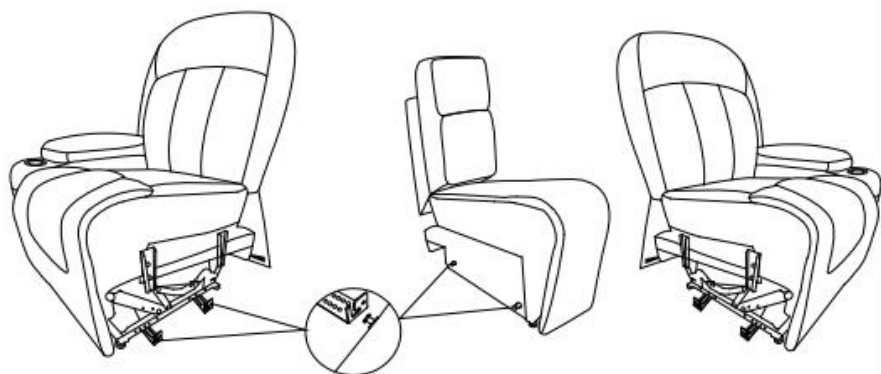

STEP 12 :Connect the power cord (X) to the power adapter (I),finally,stick up the Velcro below.Connect the power cord to the middle seat.

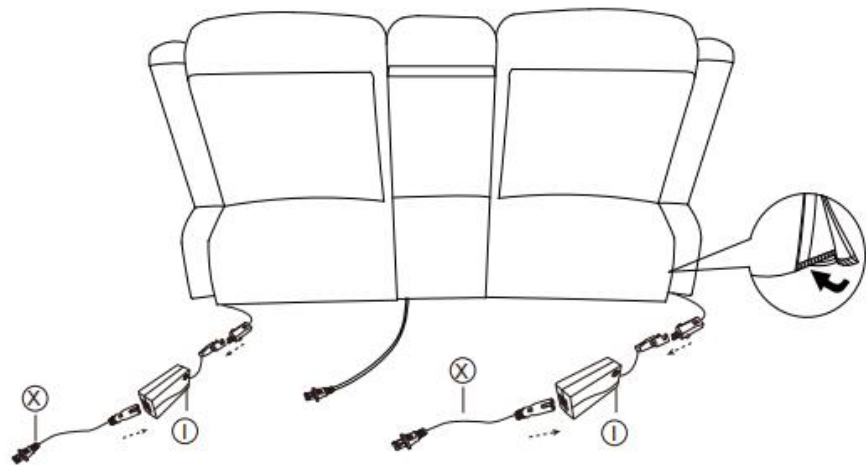

Congratulations! You've assembled
Your Sofa!

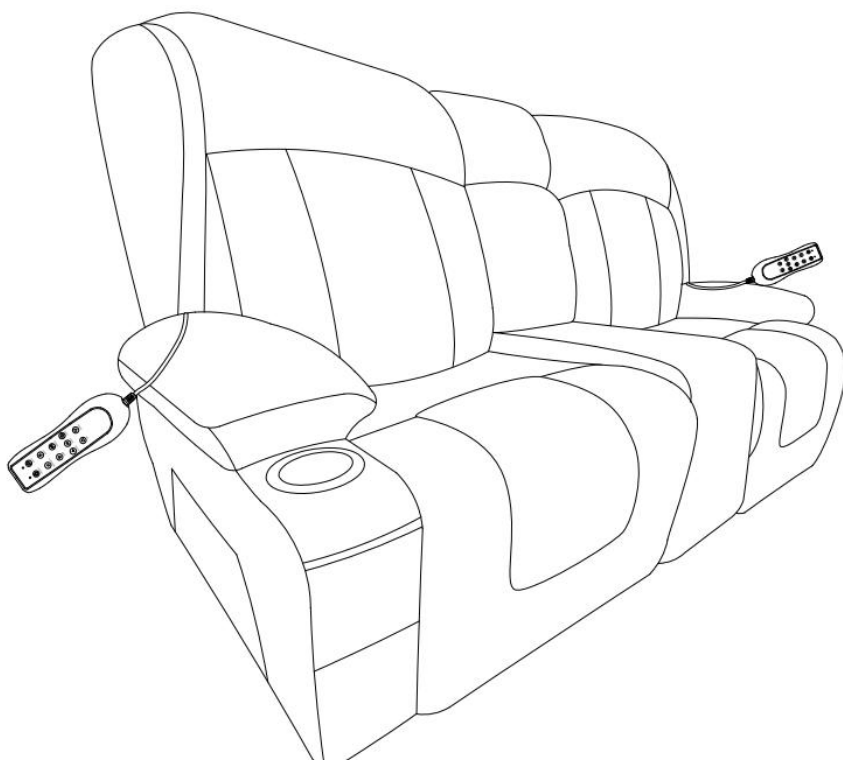

Note:

Since the backrest is packed in compression, after the product is installed, you need to tap and adjust the backrest which can help restore fullness. After two days, you will get a Overstuffed Recliners as picture shows.

OPERATING INSTRUCTION

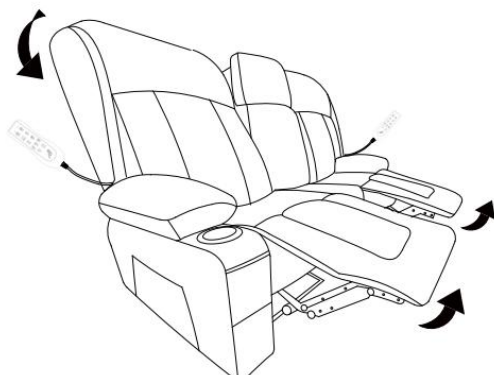

Press the switch to open the sofa

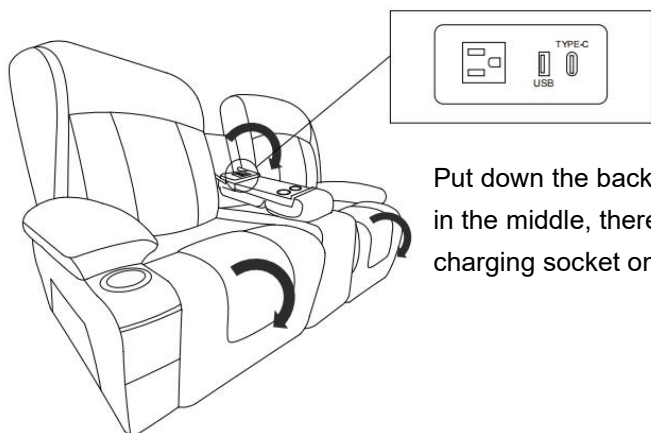

Put down the backrest
in the middle, there is a
charging socket on it.

Press the switch to lift the sofa

FUNCTION OF THE REMOTE CONTROL

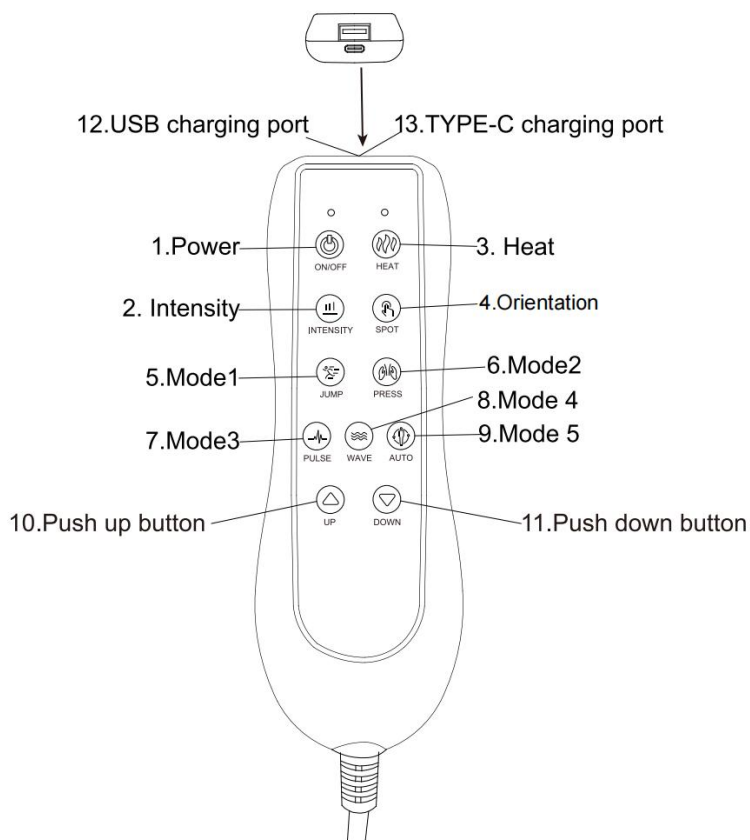

Product features

1. 4 Position, 8 Vibration motor
2. 5 motor vibration modes
3. Add hot spots to one part
4. The default shutdown duration is 15 minutes
5. 1 way electric push rod
6. USB/TYPE-C charging function

Function details

1. Switch on and off (Boot vibration full on (default strong/automatic mode))

2. Switch point by vibration intensity

3. Click heating switch circulation

4. Vibration positioning key

By default, the vibration is fully on when the machine is started

Sequence switch motor vibration in individual parts (back vibration → waist vibration → Leg vibration → Neck vibration → full open) cycle

5. Mode 1 (Skip mode)

6. Mode 2 (Press vibration mode)

7. Mode 3 (Pulse vibration mode)

8. Mode 4 (Wave vibration mode)

9. Mode 5 (Conventional vibration mode)

10. Long press the push rod upward

11. Long press the putter down

12. USB charging port

13. TYPE-C charging port

WARNINGS

- Siéntese con cuidado en la silla. Para evitar que se vuelque, no se arroje sobre ella. Recuéstela lentamente, asegurándose de que no haya niños ni mascotas cerca. No permita que los niños jueguen sobre la silla ni alrededor de ella, especialmente cuando esté abierta.
- Cierre completamente el sillón reclinable antes de levantarse de él.
- Nunca se sienta en el reposapiés cuando esté abierto, incluso si es un niño.
- Para eliminar el riesgo de vuelco, no se sienta en los brazos ni en el reposapiés de la silla.
- Esta silla está diseñada para ser utilizada por 1 adulto a la vez.
- Por favor, prohíba el uso de este sofá a personas con las siguientes dolencias: Aquellas personas con síntomas severos de enfermedad cardíaca, presión arterial alta, trombosis cerebral y otras que sean sensibles al calor o completamente insensibles al calor, aquellas con huesos frágiles o que tengan problemas con el soporte de la cintura, mujeres embarazadas, niños y otras personas que se haya determinado que no son aptas para usar este producto bajo la guía de los médicos.
- Para reclinar completamente el sofá, asegúrese de que esté bien apoyado, debe colocarlo al menos a 19 pulgadas de la pared o cualquier otro obstáculo.
- El producto no puede entrar en contacto con agua, fuego, etc. El producto tampoco puede entrar en contacto con objetos afilados (cuchillos, clavos, etc.)

MAINTENANCE MANUAL INSTRUCTIONS

- Para evitar que se caiga, debes transportar el sofá con cuidado.
- Si encuentra suciedad o manchas en el sillón, rocíe el sofá con un limpiador específico para sofás y luego use una esponja o un paño para limpiar la suciedad. No use agua, agua jabonosa ni limpiadores en las zonas de madera enceradas. Limpie el sofá con cuidado y

delicadeza.

- No coloque el sofá en un área con luz solar directa y no lo coloque directamente frente a un acondicionador de aire, esto desteñirá la tapicería y la hará quebradiza.

HOW TO DISASSEMBLE

Please find a strong tool to prod the small piece of metal grooves, then the backrest will be pulled out. The tool is not included.

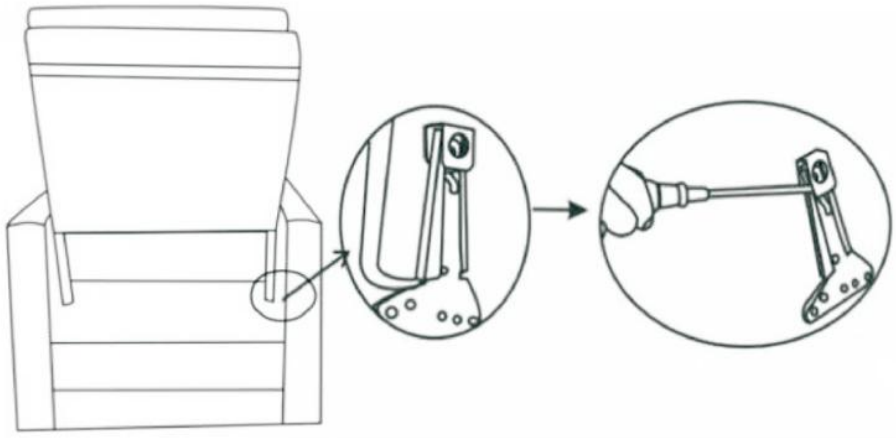

PRODUCT PARAMETER

Modelo	A1503-2DLR
Calificación(es)	100 V-240 V 50/60 Hz 1,5 A
Color principal	Marrón
Capacidad de carga de un solo asiento	330 libras
Tamaño del producto (D*An*Al)	965*1830*1080 mm
Peso neto	75 kilos

* Los productos como las especificaciones, la apariencia y el diseño están sujetos a modificaciones sin previo aviso.

Fabricante: Shanghaimuxinmuyeyouxiangongsi

Dirección: Shuangchenglu 803nong11hao1602A-1609shi, baoshanqu, shanghai 200000 CN.

Importado a AUS: SIHAO PTY LTD. 1 ROKEVA STREET, EASTWOOD, NSW 2122, Australia

Importado a EE. UU.: Sanven Technology Ltd. Suite 250, 9166 Anaheim Place, Rancho Cucamonga, CA 91730

EC	REP
-----------	------------

E-CrossStu GmbH
Mainzer Landstr.69, 60329 Frankfurt am Main.

UK	REP
-----------	------------

YH CONSULTING LIMITED.
C/O YH Consulting Limited Office 147, Centurion House, London Road, Staines-upon-Thames, Surrey, TW18 4AX



VEVOR

Affordable. Reliable. Home Improvement.

POLTRONA RECLINABILE IN TESSUTO

MODELLO: A1503-2DLR

Video con istruzioni per l'installazione della poltrona reclinabile in tessuto :

d2qc09r11gfuof.cloudfront.net/product/DBYSRSFDDKDAD7LT001/fabric+Loveseat+Recliner+Installation+Instruction+Video.mp4



VEVOR



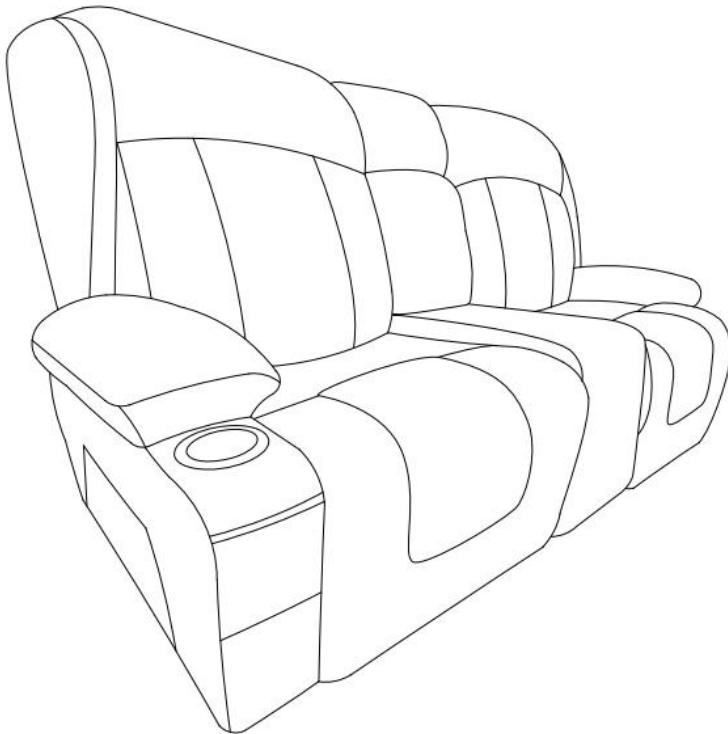

Affordable. Reliable. Home Improvement.

Fabric Loveseat
Recliner

MODELLO: A1503-2DLR



Queste sono le istruzioni originali, si prega di leggere attentamente tutte le istruzioni del manuale prima di utilizzare il prodotto. VEVOR si riserva la piena interpretazione del manuale utente. L'aspetto del prodotto dipenderà dal prodotto ricevuto. Vi preghiamo di non informarvi ulteriormente in caso di aggiornamenti tecnologici o software relativi al nostro prodotto.

	<p>Avvertenza: per ridurre il rischio di lesioni, l'utente deve leggere attentamente il manuale di istruzioni.</p>
	<p>La conformità è una certificazione di sicurezza C E.</p>
	<p>SMALTIMENTO CORRETTO</p> <p>Questo prodotto è soggetto alle disposizioni della Direttiva Europea 2012/19/CE. Il simbolo raffigurante un bidone della spazzatura barrato indica che il prodotto richiede la raccolta differenziata nell'Unione Europea. Questo vale per il prodotto e tutti gli accessori contrassegnati da questo simbolo. I prodotti contrassegnati come tali non possono essere smaltiti con i normali rifiuti domestici, ma devono essere conferiti presso un punto di raccolta per il riciclaggio di apparecchiature elettriche ed elettroniche .</p>
	<p>Attenzione: solo per uso interno</p>
	<p>Informazioni FCC:</p> <p>ATTENZIONE: Cambiamenti o modifiche non espressamente approvati dalla parte responsabile della conformità potrebbero invalidare il diritto dell'utente a utilizzare l'apparecchiatura!</p> <p>Questo dispositivo è conforme alla Parte 15 delle Norme FCC. Il funzionamento è soggetto alle seguenti due condizioni:</p> <ol style="list-style-type: none"> 1) Questo prodotto potrebbe causare interferenze dannose. 2) Questo prodotto deve accettare qualsiasi interferenza ricevuta, comprese quelle che potrebbero causare un funzionamento indesiderato. <p>ATTENZIONE: eventuali modifiche o alterazioni apportate al prodotto non espressamente approvate dalla parte responsabile della conformità potrebbero invalidare il diritto dell'utente a utilizzare il prodotto.</p> <p>Nota: questo prodotto è stato testato e ritenuto conforme ai limiti per i dispositivi digitali di Classe B, ai sensi della Parte 15 delle Norme FCC. Tali limiti sono concepiti per fornire una protezione ragionevole</p>

contro interferenze dannose in un'installazione residenziale. Questo prodotto genera, utilizza e può irradiare energia a radiofrequenza e, se non installato e utilizzato in conformità con le istruzioni, può causare interferenze dannose alle comunicazioni radio. Tuttavia, non vi è alcuna garanzia che non si verifichino interferenze in una particolare installazione. Se questo prodotto causa interferenze dannose alla ricezione radiofonica o televisiva, verificabili spegnendo e riaccendendo il prodotto, si consiglia all'utente di provare a correggere l'interferenza adottando una o più delle seguenti misure.

- Riorientare o riposizionare l'antenna ricevente.
- Aumentare la distanza tra il prodotto e il ricevitore.
- Collegare il prodotto a una presa di corrente appartenente a un circuito diverso da quello a cui è collegato il ricevitore.
- Per assistenza, rivolgersi al rivenditore o a un tecnico radio/TV esperto.

SAFETY INSTRUCTIONS

AVVERTIMENTO:

Leggere attentamente questo materiale prima di utilizzare il prodotto. La mancata osservanza di queste istruzioni può causare gravi lesioni.

Precauzioni di montaggio

1. Montare solo secondo queste istruzioni. Un montaggio improprio può comportare pericoli.
2. Durante il montaggio, indossare occhiali di sicurezza omologati ANSI e guanti da lavoro resistenti.
3. Mantenere l'area di riunione pulita e ben illuminata.
4. Tenere gli astanti fuori dall'area durante l'assemblea.
5. Non partecipare se si è stanchi o sotto l'effetto di alcol, droghe o medicinali.
6. Inoltre, sebbene sia possibile montare la sedia da soli, avere una seconda persona che vi aiuti rende il tutto ancora più semplice.
7. Le capacità del prodotto si applicano solo ai prodotti correttamente e completamente assemblati.
8. Montare su una superficie piana, orizzontale, dura e liscia, in grado di sostenere in modo sicuro la poltrona reclinabile Fabric Loveseat.
9. Prima di iniziare, controlla che non manchino parti nella confezione. In caso di problemi, non esitare a contattarci via email e ti aiuteremo il prima possibile.
10. Per ulteriori informazioni sui componenti elencati nelle pagine seguenti, fare riferimento allo schema di montaggio di questo manuale.
Disimballare e separare tutti i componenti in un'area di lavoro pulita.

Usare precauzioni

1. Da utilizzare solo come previsto.
2. Controllare prima di ogni utilizzo; non utilizzare se alcune parti risultano allentate o danneggiate.

CONSERVARE QUESTO MANUALE

PARTS LIST

 Seat cushion (A)*1	 Seat cushion (A)*1	 L Back (B)*1	 R Back (B)*1
 Middle Back (B)*1	 L Seat frame (C)*1	 R Seat frame (C)*1	 Middle Seat (C)*1
 F (L) Armrest bag (F)*1	 F (R) Armrest bag (F)*1	 L*1 Back ear	 R*1 Back ear
 Massage remote control board (G)*2	 Motor power supply (I)*2	 Power line (X)*2	 Glove *2
 Cup holder *2	 Screw (N)*8	 Spanner (O)*1	 Connector *4
 Screw (S)*4	 Spacer (T)*4		
 Under the frame			

ASSEMBLY STEP

STEP 1: Open the compression bag and remove the soft bag.

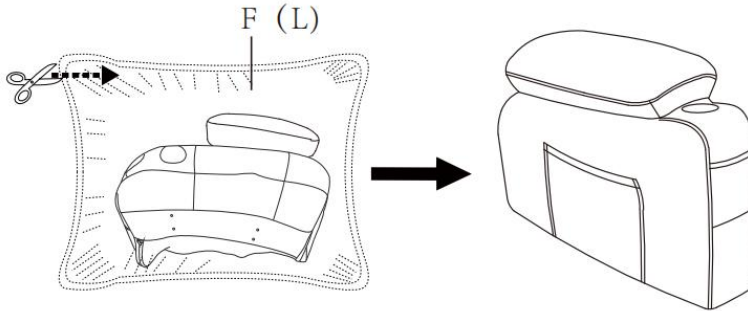

STEP 2: Repeat Step 1.

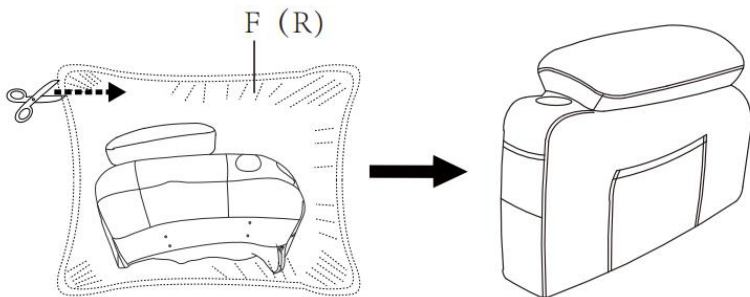

STEP 3: Fix the connector to the inside of the armrest with M6x16mm screws, paying attention to the direction of fixing the connector.

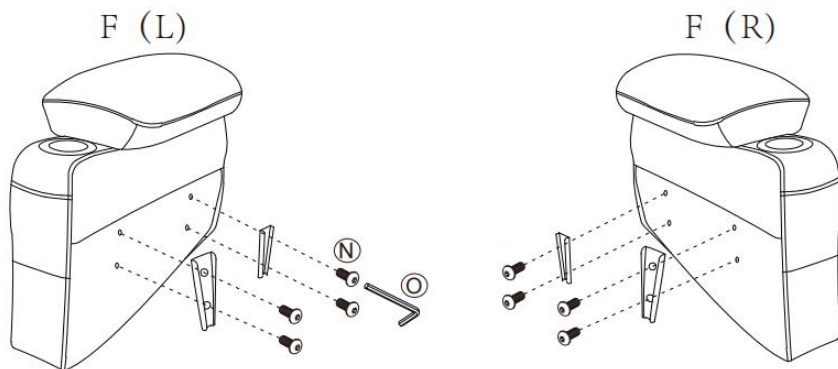

STEP 4: Fix the screws on both sides of the middle seat.

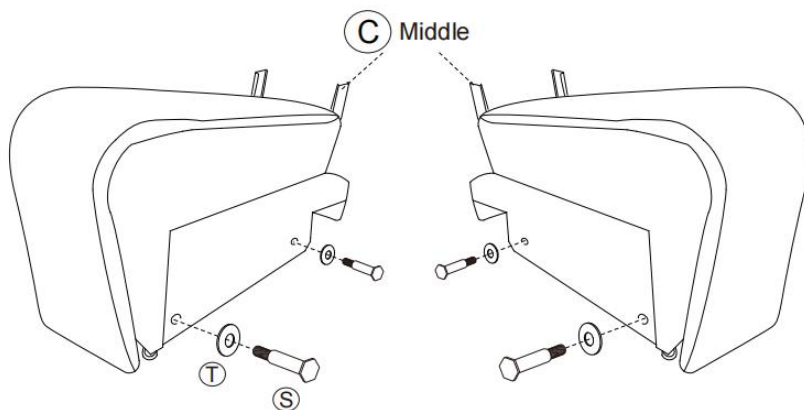

STEP 5:Place the cup holder into the groove.

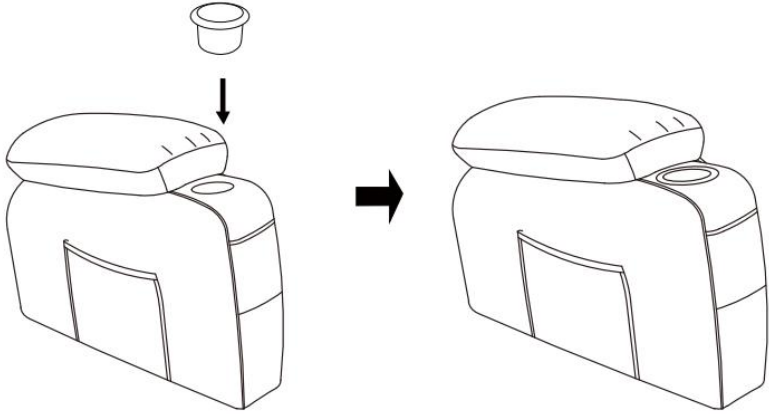

STEP 6:Insert arms so that they can fit into the seat, you will hear a “click” when they are engaged.

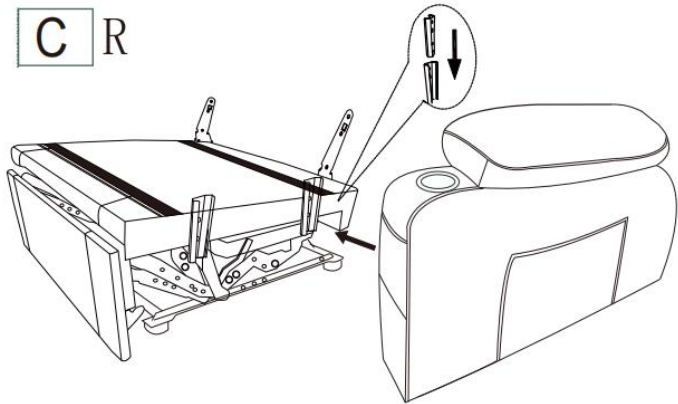

STEP7: Repeat Step 6

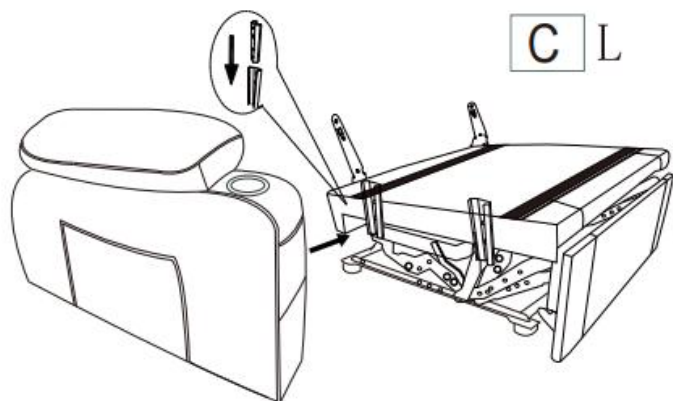

STEP8: Open seat bag A, stick the Velcro on the footboard, and stick the Velcro on the seat bag.

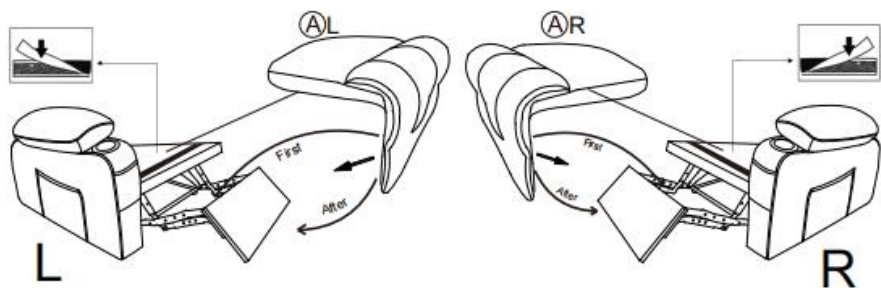

Note: First, power on, turn on the footrest, and then install the seat cushion

STEP 9: Plug the back pad into the seat frame, then connect the massager lines: white with white, red with red, black with the power lines, connect the massage line with the handcontroller.

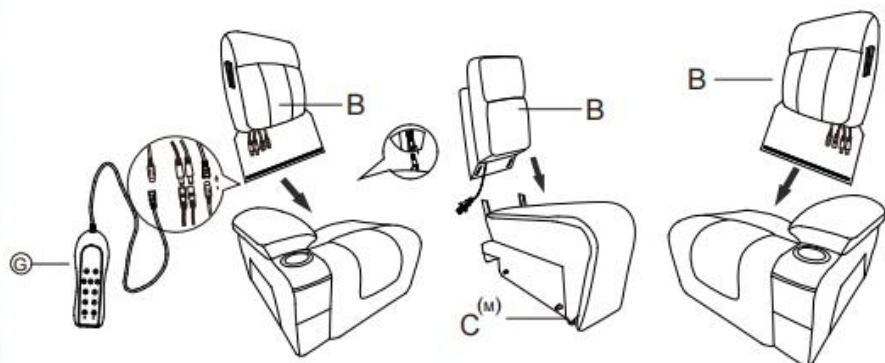

STEP 10: Install the back ears on both sides of the backrest.

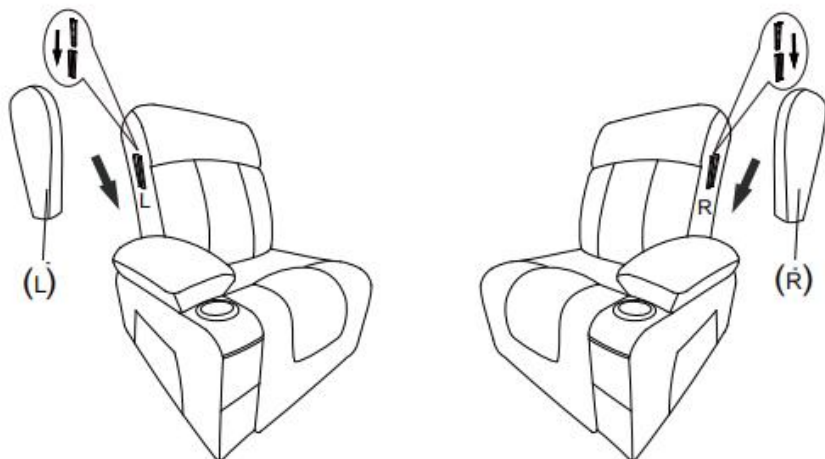

STEP 11 :Hang the middle position on the pendant slots on the left and right positions, and the three chairs can be connected together.

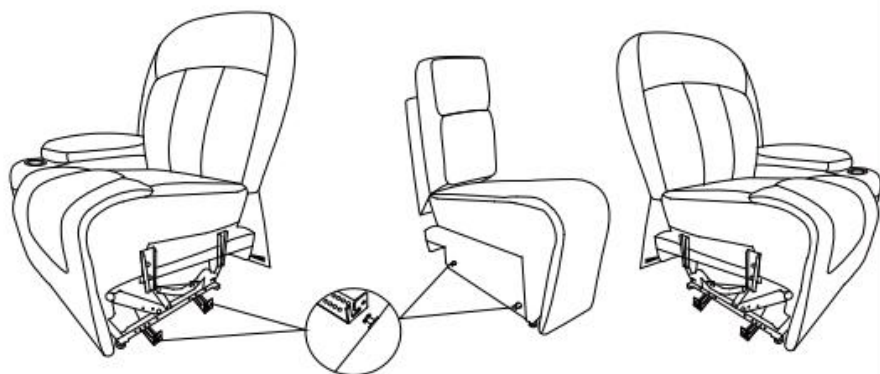

STEP 12 :Connect the power cord (X) to the power adapter (I),finally,stick up the Velcro below.Connect the power cord to the middle seat.

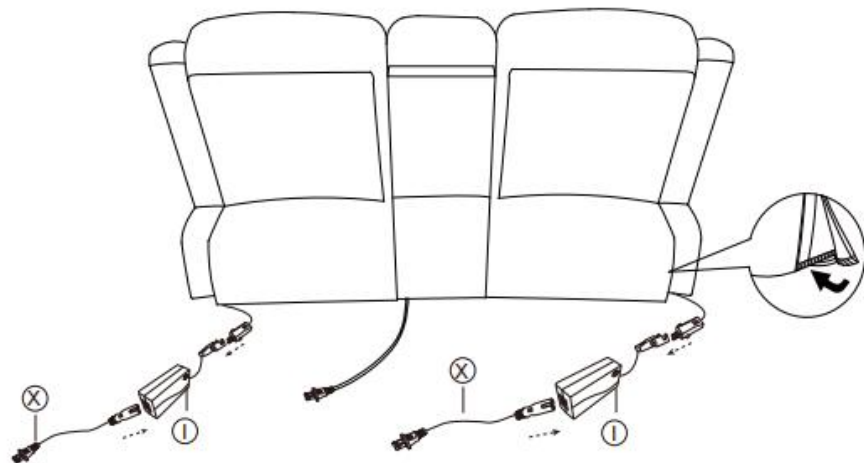

Congratulations! You've assembled
Your Sofa!

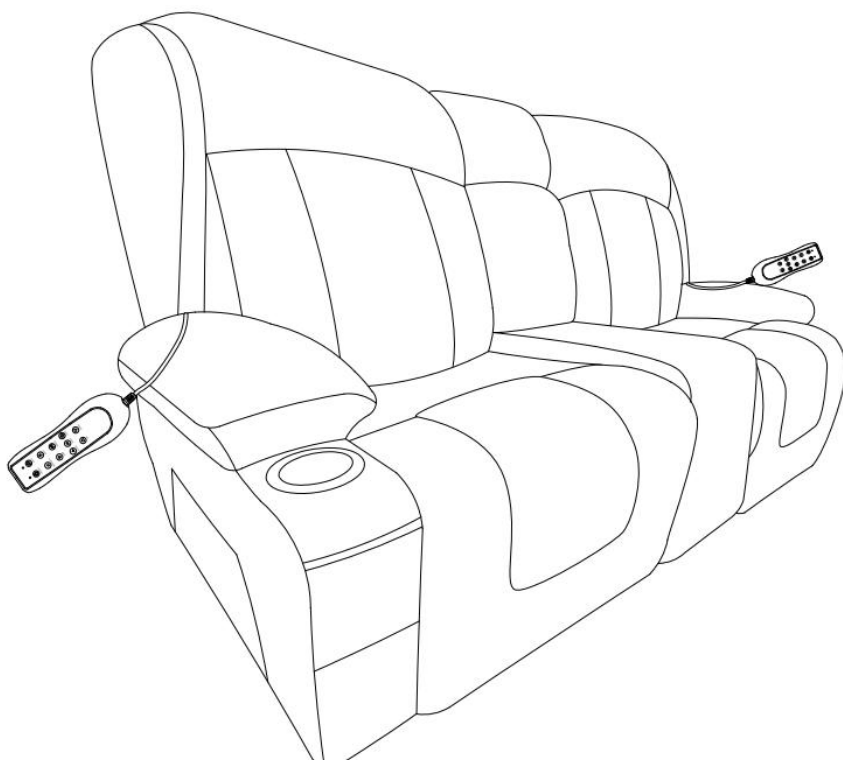

Note:

Since the backrest is packed in compression, after the product is installed, you need to tap and adjust the backrest which can help restore fullness. After two days, you will get a Overstuffed Recliners as picture shows.

OPERATING INSTRUCTION

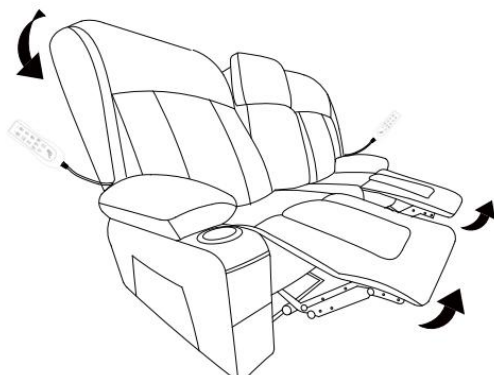

Press the switch to open the sofa

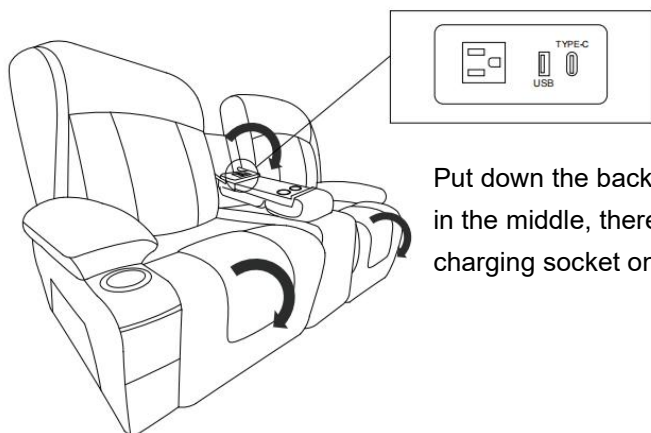

Put down the backrest in the middle, there is a charging socket on it.

Press the switch to lift the sofa

FUNCTION OF THE REMOTE CONTROL

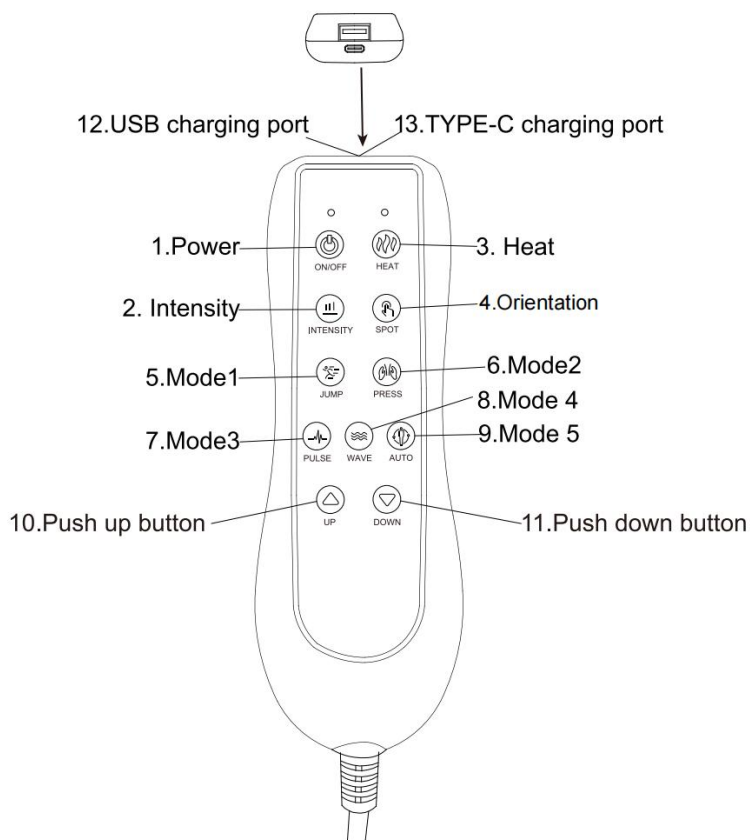

Product features

1. 4 Position, 8 Vibration motor
2. 5 motor vibration modes
3. Add hot spots to one part
4. The default shutdown duration is 15 minutes
5. 1 way electric push rod
6. USB/TYPE-C charging function

Function details

1. Switch on and off (Boot vibration full on (default strong/automatic mode))

2. Switch point by vibration intensity

3. Click heating switch circulation

4. Vibration positioning key

By default, the vibration is fully on when the machine is started

Sequence switch motor vibration in individual parts (back vibration → waist vibration → Leg vibration → Neck vibration → full open) cycle

5. Mode 1 (Skip mode)

6. Mode 2 (Press vibration mode)

7. Mode 3 (Pulse vibration mode)

8. Mode 4 (Wave vibration mode)

9. Mode 5 (Conventional vibration mode)

10. Long press the push rod upward

11. Long press the putter down

12. USB charging port

13. TYPE-C charging port

WARNINGS

- Sedetevi delicatamente sulla sedia. Per evitare di ribaltarvi, non buttatevi sulla sedia. Portate lentamente la sedia in posizione reclinata, assicurandovi che non vi siano bambini o animali domestici nelle vicinanze. Non permettete ai bambini di giocare sopra o intorno alla sedia, soprattutto quando è in posizione aperta.
- Chiudere completamente la poltrona reclinabile prima di uscirne.
- Non sedersi mai sul poggiatesta quando è aperto, nemmeno se si tratta di un bambino.
- Per evitare il rischio di ribaltamento, non sedersi sui braccioli o sul poggiatesta della sedia.
- Questa sedia è progettata per essere utilizzata da un adulto alla volta.
- Si prega di vietare l'uso di questo divano alle persone con i seguenti disturbi: persone con gravi sintomi di malattie cardiache, pressione alta, trombosi cerebrale e altre persone sensibili al calore o completamente insensibili al calore, persone con ossa fragili o problemi con il supporto della vita, donne incinte, bambini e altre persone per le quali è stato determinato che non sono adatte all'uso di questo prodotto sotto la guida di un medico.
- Per reclinare completamente il divano, accertarsi che sia ben posizionato e che la distanza dal muro o da qualsiasi altro ostacolo sia di almeno 48 cm.
- Il prodotto non può entrare in contatto con acqua, fuoco, ecc. Il prodotto non può inoltre entrare in contatto con oggetti appuntiti (coltelli, chiodi, ecc.)

MAINTENANCE MANUAL INSTRUCTIONS

- Per evitare che il divano cada, trasportatelo con cautela.
- Se trovate sporco e/o macchie sulla poltrona, spruzzate il divano con un detergente specifico per divani e poi usate una spugna o un panno per rimuovere lo sporco. Non usate acqua, acqua saponata o detersivi per le superfici in legno cerato. Assicuratevi di pulire il

divano con cura e delicatezza.

- Non posizionare il divano in una zona esposta alla luce diretta del sole e non posizionarlo direttamente davanti a un condizionatore, poiché ciò potrebbe sbiadire il rivestimento e renderlo fragile.

HOW TO DISASSEMBLE

Please find a strong tool to prod the small piece of metal grooves, then the backrest will be pulled out. The tool is not included.

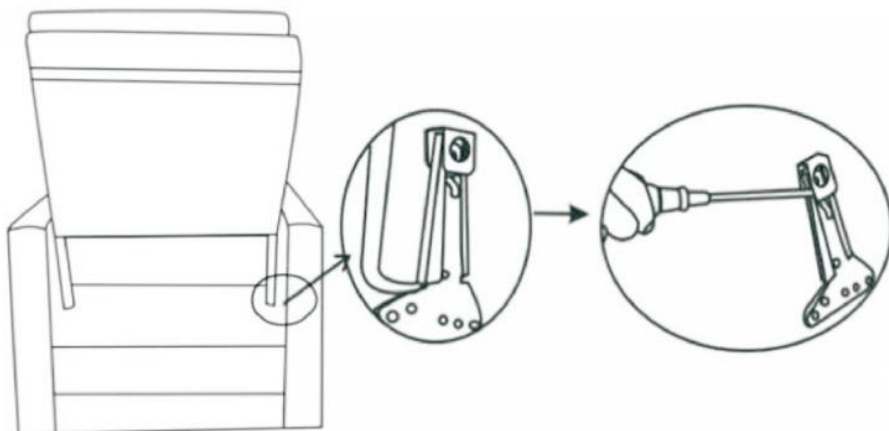

PRODUCT PARAMETER

Modello	A1503-2DLR
Valutazione(i)	100 V-240 V 50/60 Hz 1,5 A
Colore principale	Marrone
Capacità di carico del singolo posto	330 libbre
Dimensioni del prodotto (P*L*A)	965*1830*1080mm
Peso netto	75 kg

* Le specifiche, l'aspetto e il design dei prodotti sono soggetti a modifiche senza preavviso.

Produttore: Shanghaimuxinmuyeyouxiangongsi

Indirizzo: Shuangchenglu 803nong11hao1602A-1609shi, baoshanqu, shanghai 200000 CN.

Importato in AUS: SIHAO PTY LTD. 1 ROKEVA STREETEASTWOOD NSW 2122 Australia

Importato negli USA: Sanven Technology Ltd. Suite 250, 9166 Anaheim Place, Rancho Cucamonga, CA 91730

EC	REP
-----------	------------

E-CrossStu GmbH
Mainzer Landstr.69, 60329 Frankfurt am Main.

UK	REP
-----------	------------

YH CONSULTING LIMITED.
C/O YH Consulting Limited Office 147, Centurion House, London Road, Staines-upon-Thames, Surrey, TW18 4AX



VEVOR

Affordable. Reliable. Home Improvement.

TYG LOVESEAT FÅTÖLJ

MODELL: A1503-2DLR

Instruktionsvideo för installation av tyg-loveseat-fåtölj :

d2qc09rl1gfuof.cloudfront.net/product/DBBYSRSFDDKDAD7LT001/tyg+Tvåsits+Fåtölj+Installation+Instruktion+Video.mp4



VEVOR



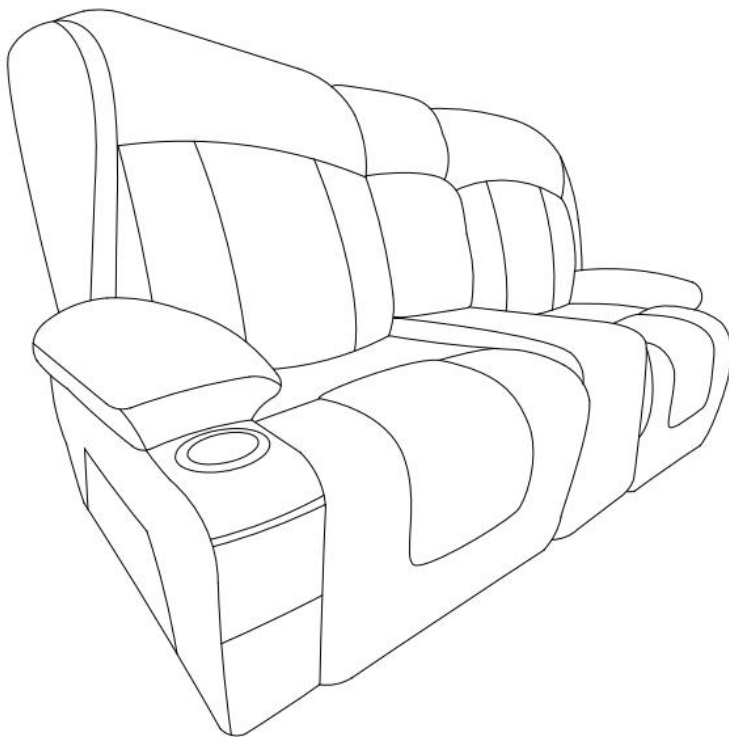

Affordable. Reliable. Home Improvement.

Fabric Loveseat
Recliner

MODELL: A1503-2DLR



Detta är originalinstruktionerna, vänligen läs alla instruktioner noggrant innan du använder produkten. VEVOR förbehåller sig en tydlig tolkning av vår användarmanual. Produktens utseende ska vara beroende av den produkt du mottagit. Vi ber om ursäkt för att vi inte kommer att informera dig igen om det finns några teknik- eller programuppdateringar för vår produkt.

	<p>Varning – För att minska risken för skador måste användaren läsa instruktionsmanualen noggrant.</p>
	<p>Efterlevnad är en CE- säkerhetscertifiering .</p>
	<p>KORREKT AVFALLSHANTERING</p> <p>Denna produkt omfattas av bestämmelserna i EU-direktiv 2012/19/EG. Symbolen som visar en överstruken soptunna indikerar att produkten kräver separat sophämtning inom Europeiska unionen. Detta gäller produkten och alla tillbehör som är märkta med denna symbol. Produkter som är märkta som sådana får inte kasseras med vanligt hushållsavfall, utan måste lämnas till en samlingsplats för återvinning av elektriska och elektroniska apparater .</p>
	<p>Varning - Endast för inomhusbruk</p>
	<p>FCC-information:</p> <p>VARNING: Ändringar eller modifieringar som inte uttryckligen godkänts av den part som ansvarar för efterlevnaden kan upphäva användarens rätt att använda utrustningen!</p> <p>Denna enhet uppfyller del 15 i FCC-reglerna. Användning är underkastad följande två villkor:</p> <ol style="list-style-type: none"> 1) Denna produkt kan orsaka skadliga störningar. 2) Denna produkt måste acceptera alla mottagna störningar, inklusive störningar som kan orsaka oönskad funktion. <p>VARNING: Ändringar eller modifieringar av denna produkt som inte uttryckligen godkänts av den part som ansvarar för efterlevnaden kan ogiltigförklara användarens rätt att använda produkten.</p> <p>Obs! Denna produkt har testats och befunnits uppfylla gränserna för en digital enhet av klass B i enlighet med del 15 i FCC-reglerna. Dessa gränser är utformade för att ge rimligt skydd mot skadlig störning i en bostadsinstallation.</p> <p>Denna produkt genererar, använder och kan utstråla radiofrekvensenergi, och om den inte installeras och används i</p>

enlighet med instruktionerna kan den orsaka skadliga störningar på radiokommunikation. Det finns dock ingen garanti för att störningar inte kommer att uppstå i en viss installation. Om denna produkt orsakar skadliga störningar på radio- eller tv-mottagning, vilket kan fastställas genom att stänga av och slå på produkten, uppmanas användaren att försöka korrigera störningen med en eller flera av följande åtgärder.

- Rikta om eller flytta mottagarantennen.
- Öka avståndet mellan produkten och mottagaren.
- Anslut produkten till ett uttag på en annan krets än den som mottagaren är ansluten till.
- Kontakta återförsäljaren eller en erfaren radio-/TV-tekniker för hjälp.

SAFETY INSTRUCTIONS

WARNING:

Läs detta material innan du använder produkten. Underlåtenhet att göra det kan leda till allvarliga skador.

Monteringsförsiktighetsåtgärder

1. Montera endast enligt dessa instruktioner. Felaktig montering kan orsaka risker.
2. Använd ANSI-godkända skyddsglasögon och kraftiga arbetshandskar under monteringen.
3. Håll samlingsområdet rent och väl upplyst.
4. Håll åskådare borta från området under monteringen.
5. Montera inte om du är trött eller påverkad av alkohol, droger eller mediciner.
6. Det är också möjligt att montera stolen själv, men att ha en andra person som hjälper dig gör det ännu enklare.
7. Produktens egenskaper gäller endast korrekt och fullständigt monterade produkter.
8. Montera på en plan, jämn, hård och slät yta som säkert kan stödja tyg-loveseat-fåtöljen.
9. Innan du börjar, kontrollera om det saknas några delar i förpackningen. Om det skulle uppstå några problem, tveka inte att skicka ett e-postmeddelande till oss så hjälper vi dig så snart som möjligt.
10. För ytterligare information om delarna som listas på följande sidor, se monteringssschemat i denna manual. Packa upp och separera alla delar på en ren arbetsyta.

Använd försiktighetsåtgärder

1. Använd endast som avsett.
2. Kontrollera före varje användning; använd inte om delar är lösa eller skadade.

SPARA DENNA HANDBOK

PARTS LIST

 Seat cushion (A)*1	 Seat cushion (A)*1	L  Back (B)*1	R  Back (B)*1
 Middle Back (B)*1	L  Seat frame (C)*1	R  Seat frame (C)*1	 Middle Seat (C)*1
 F (L) Armrest bag (F)*1	 F (R) Armrest bag (F)*1	 Back ear L*1	 Back ear R*1
 Massage remote control board (G)*2	 Motor power supply (I)*2	 Power line (X)*2	 Glove *2
 Cup holder *2	 Screw (N)*8	 Spanner (O)*1	 Connector *4
 Screw (S)*4	 Spacer (T)*4		
<div style="display: flex; align-items: center;"> <div style="margin-right: 20px;"> <p>Under the frame</p>  </div> <div style="margin-right: 20px;">  </div> <div style="display: flex; flex-direction: column; align-items: center;"> <div style="margin-bottom: 10px;">  </div> <div>  </div> </div> </div>			

ASSEMBLY STEP

STEP 1: Open the compression bag and remove the soft bag.

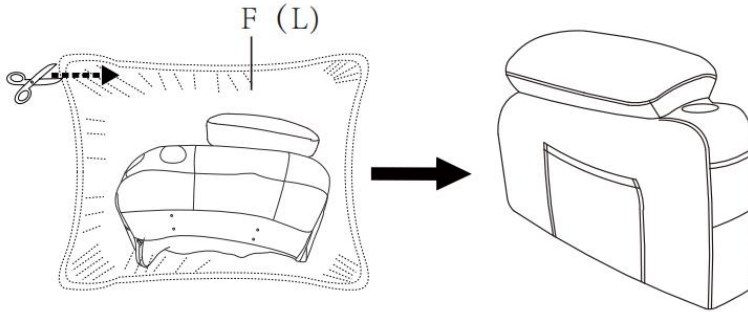

STEP 2: Repeat Step 1.

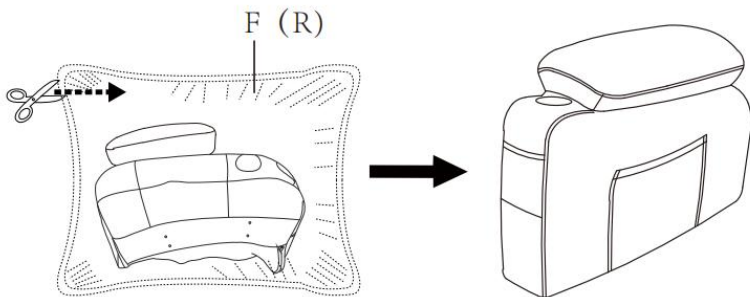

STEP 3: Fix the connector to the inside of the armrest with M6x16mm screws, paying attention to the direction of fixing the connector.

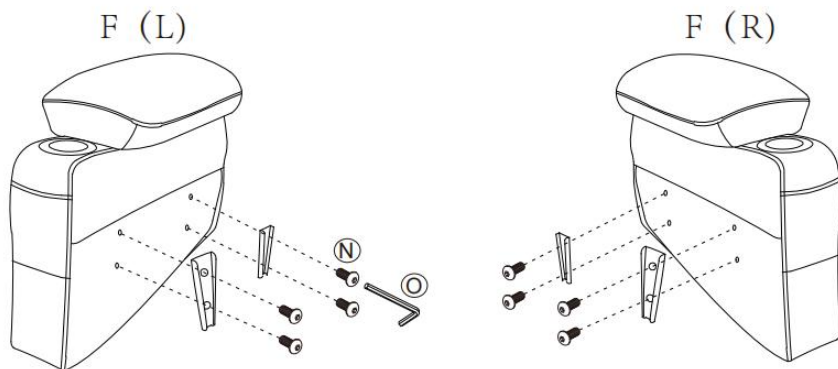

STEP 4: Fix the screws on both sides of the middle seat.

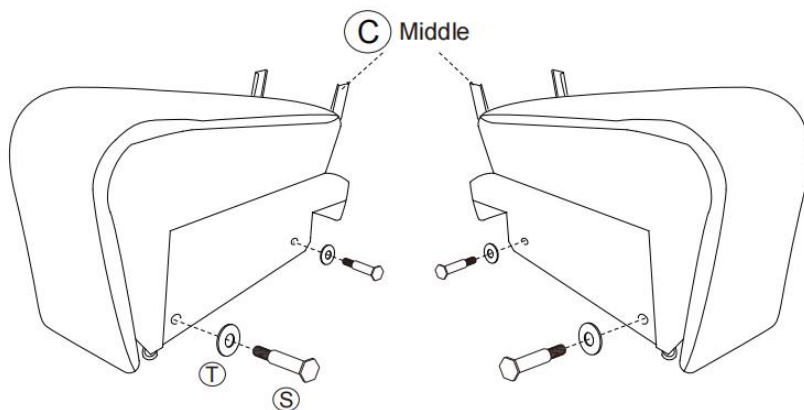

STEP 5:Place the cup holder into the groove.

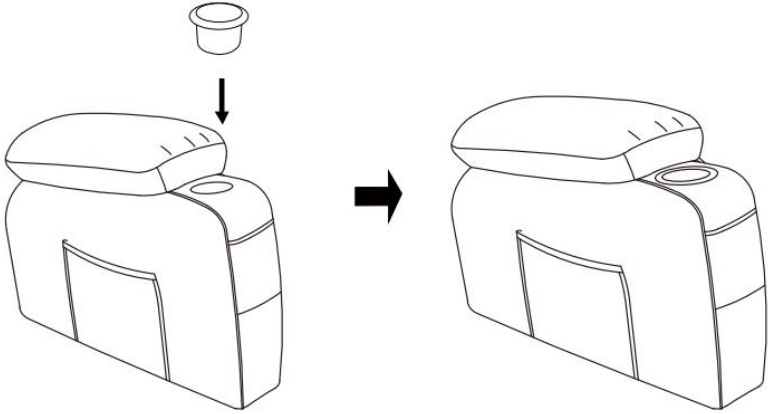

STEP 6:Insert arms so that they can fit into the seat, you will hear a “click” when they are engaged.

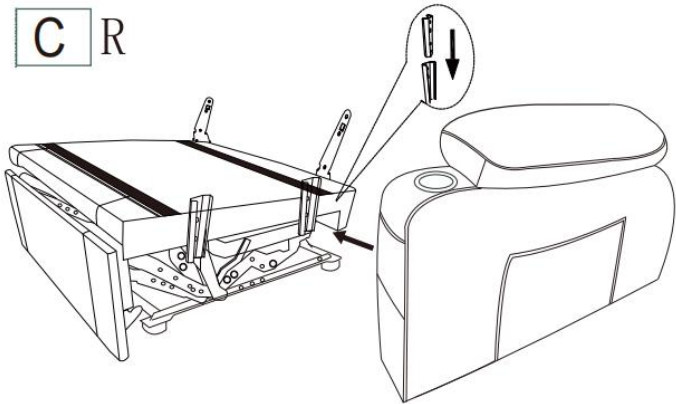

STEP7: Repeat Step 6

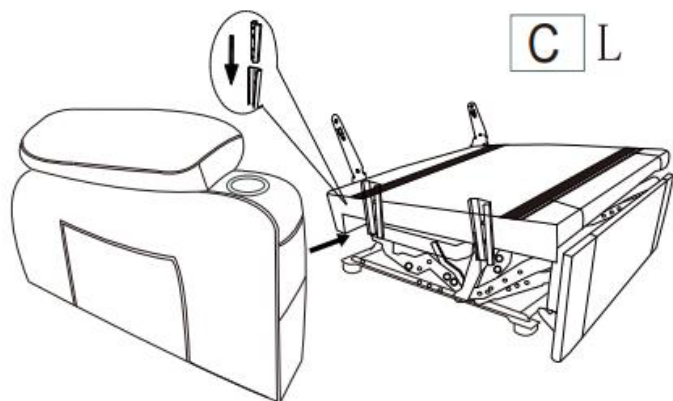

STEP8: Open seat bag A, stick the Velcro on the footboard, and stick the Velcro on the seat bag.

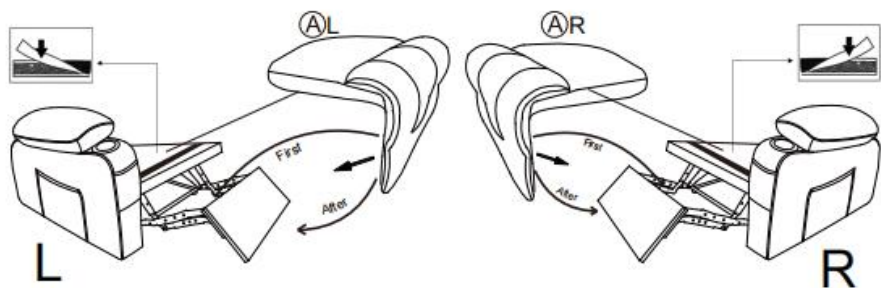

Note: First, power on, turn on the footrest, and then install the seat cushion

STEP 9: Plug the back pad into the seat frame, then connect the massager lines: white with white, red with red, black with the power lines, connect the massage line with the handcontroller.

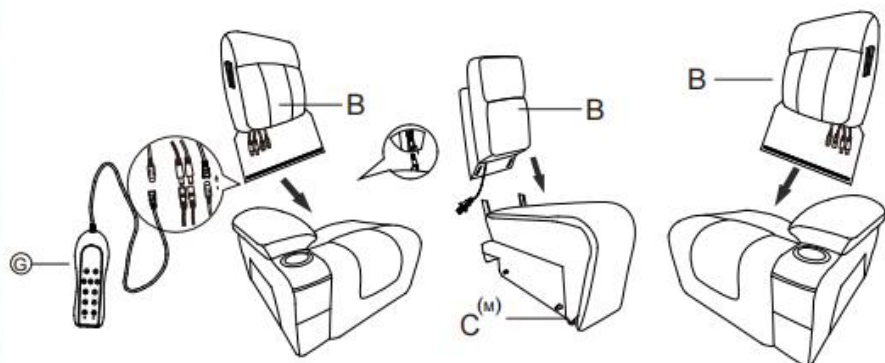

STEP 10: Install the back ears on both sides of the backrest.

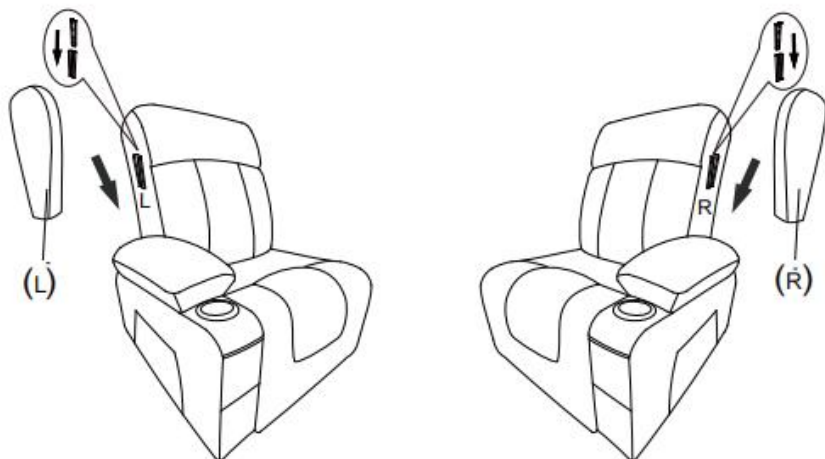

STEP 11 :Hang the middle position on the pendant slots on the left and right positions, and the three chairs can be connected together.



STEP 12 :Connect the power cord (X) to the power adapter (I),finally,stick up the Velcro below.Connect the power cord to the middle seat.

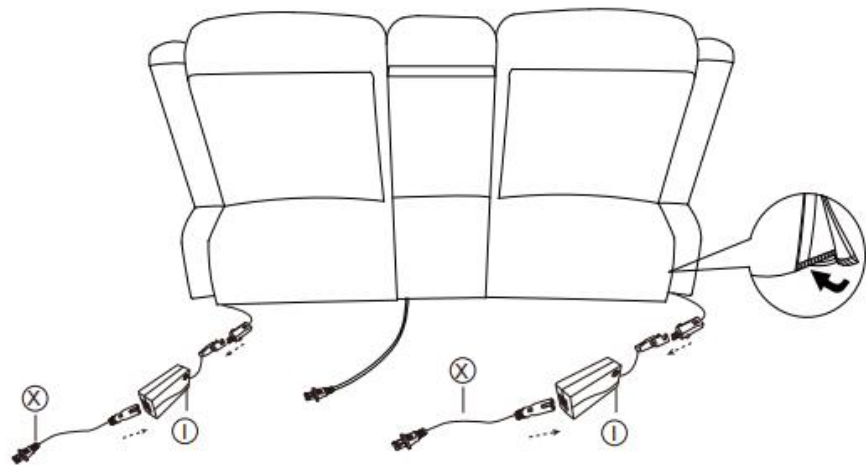

Congratulations! You've assembled
Your Sofa!

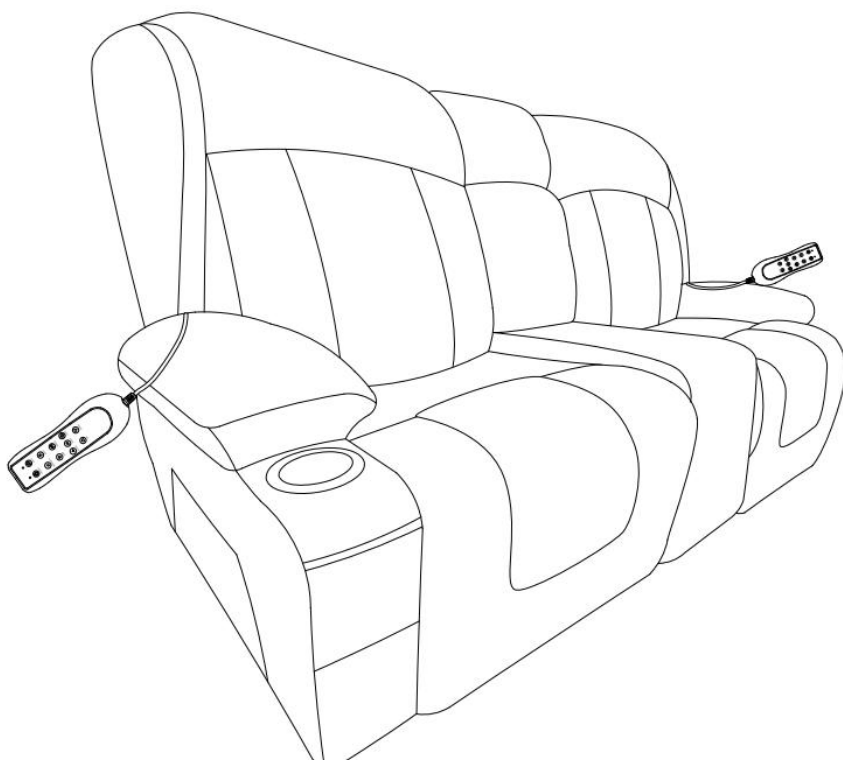

Note:

Since the backrest is packed in compression, after the product is installed, you need to tap and adjust the backrest which can help restore fullness. After two days, you will get a Overstuffed Recliners as picture shows.

OPERATING INSTRUCTION

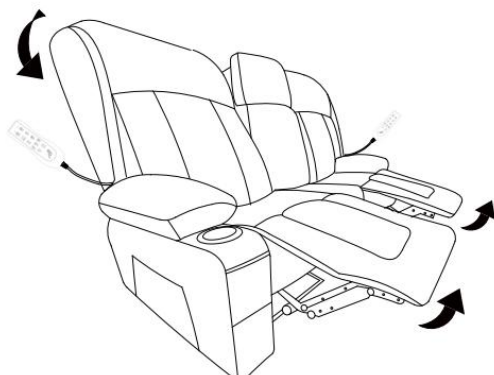

Press the switch to open the sofa

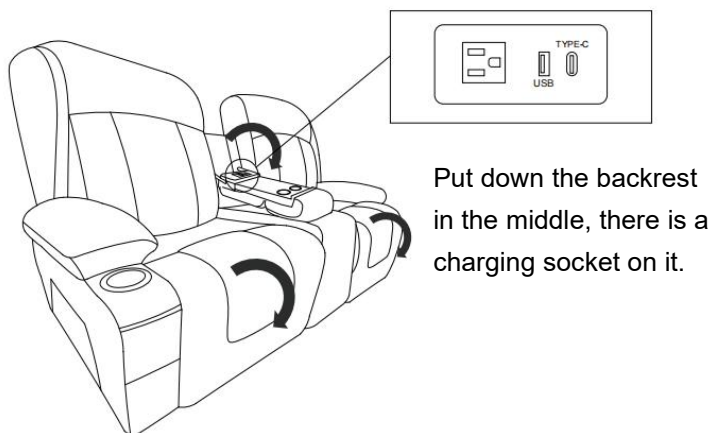

Put down the backrest in the middle, there is a charging socket on it.

Press the switch to lift the sofa

FUNCTION OF THE REMOTE CONTROL

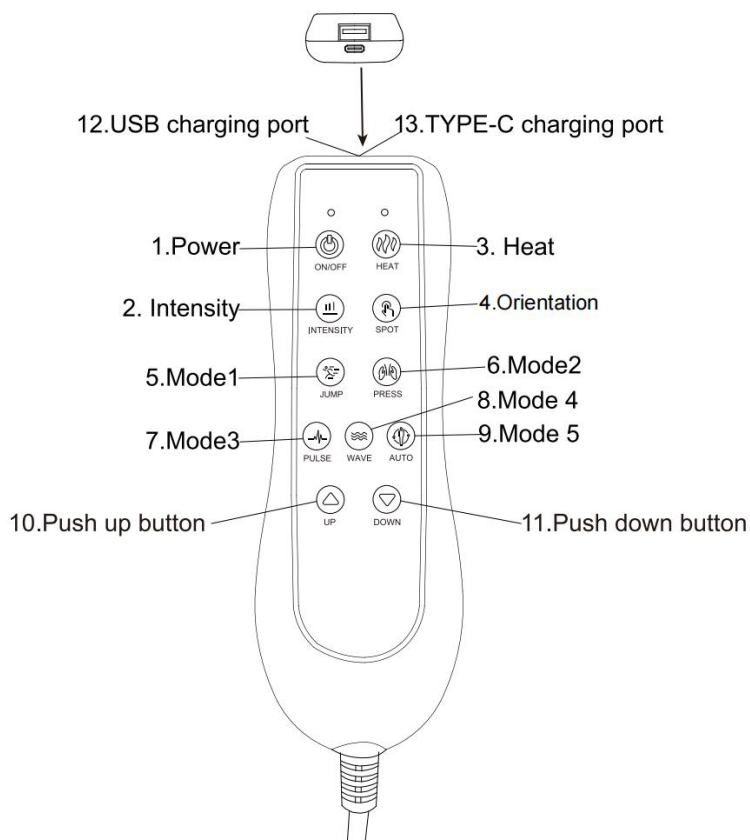

Product features

1. 4 Position, 8 Vibration motor
2. 5 motor vibration modes
3. Add hot spots to one part
4. The default shutdown duration is 15 minutes
5. 1 way electric push rod
6. USB/TYPE-C charging function

Function details

1. Switch on and off (Boot vibration full on (default strong/automatic mode))

2. Switch point by vibration intensity

3. Click heating switch circulation

4. Vibration positioning key

By default, the vibration is fully on when the machine is started

Sequence switch motor vibration in individual parts (back vibration → waist vibration → Leg vibration → Neck vibration → full open) cycle

5. Mode 1 (Skip mode)

6. Mode 2 (Press vibration mode)

7. Mode 3 (Pulse vibration mode)

8. Mode 4 (Wave vibration mode)

9. Mode 5 (Conventional vibration mode)

10. Long press the push rod upward

11. Long press the putter down

12. USB charging port

13. TYPE-C charging port

WARNINGS

- Sätt dig försiktigt ner i stolen. För att undvika att välta, kasta dig inte ner i stolen. Flytta stolen långsamt till tillbakalutat läge och se till att inga barn eller husdjur befinner sig i närheten. Låt inte barn leka på eller runt stolen, särskilt inte när den är i öppet läge.
- Stäng fåtöljen helt innan du kliver ur den.
- Sitt aldrig på fotstödet när det är öppet, inte ens om det är ett barn.
- För att eliminera risken för att välta, sitt inte på stolens armstöd eller fotstöd.
- Denna stol är avsedd att användas av en vuxen åt gången.
- Förbjud personer med följande åkommor att använda denna soffa: Personer med svåra symtom på hjärtsjukdom, högt blodtryck, hjärntrombos och andra som är värmekänsliga eller helt okänsliga för värme, personer med benskörhet eller har problem med midjestöd, gravida kvinnor, barn och andra för vilka det har bedömts att de inte är lämpliga att använda denna produkt under läkarvård.
- För att kunna luta soffan helt tillbaka, se till att den är ordentligt placerad. Du måste placera soffan minst 45 cm från väggen eller andra hinder.
- Produkten får inte komma i kontakt med vatten, eld etc. Produkten får inte heller komma i kontakt med vassa föremål (knivar, spikar etc.).

MAINTENANCE MANUAL INSTRUCTIONS

- För att undvika att falla soffan bör du bära den försiktigt.
- Om du hittar smuts och/eller fläckar på fåtöljen, spraya soffan med ett särskilt soffrengöringsmedel och använd sedan en svamp eller trasa för att torka bort smutsen. Använd inte vatten, tvålvatten eller rengöringsmedel på vaxade träytor. Var noga med att torka soffan försiktigt och försiktigt.
- Placera inte soffan i direkt solljus och placera den inte direkt framför en luftkonditionering, det kommer att blekna klädseln och göra den spröd.

HOW TO DISASSEMBLE

Please find a strong tool to prod the small piece of metal grooves, then the backrest will be pulled out. The tool is not included.

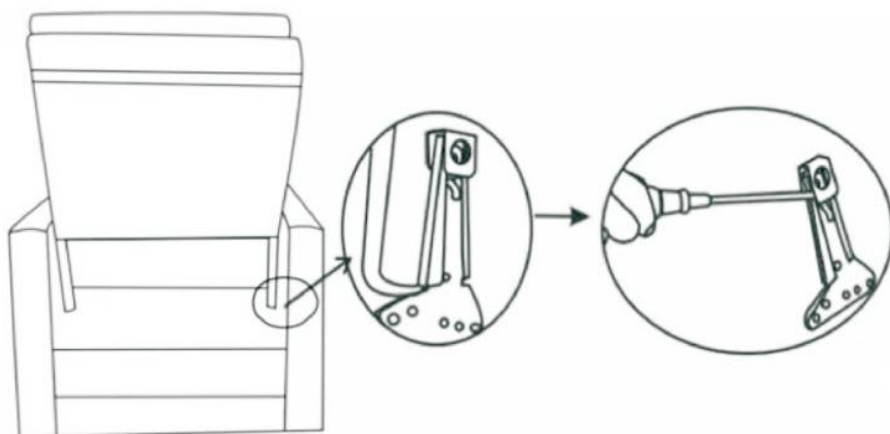

PRODUCT PARAMETER

Modell	A1503-2DLR
Betyg(en)	100V-240V 50/60Hz 1,5A
Huvudfärg	Brun
Bärförmåga för enstaka säten	147 kg
Produktstorlek (D*B*H)	965*1830*1080mm
Nettovikt	75 kg

* Produkters specifikationer, utseende och design kan komma att ändras utan föregående meddelande.

Tillverkare: Shanghaimuxinmuyeyouxiangongsi

Adress: Shuangchenglu 803nong11hao1602A-1609shi, baoshanqu, shanghai 200000 CN.

Importerad till Australien: SIHAO PTY LTD. 1 ROKEVA
STREETEASTWOOD NSW 2122 Australien

Importerad till USA: Sanven Technology Ltd. Suite 250, 9166 Anaheim
Place, Rancho Cucamonga, CA 91730

EC	REP
-----------	------------

E-CrossStu GmbH
Mainzer Landstr.69, 60329 Frankfurt am Main.

UK	REP
-----------	------------

YH CONSULTING LIMITED.
C/O YH Consulting Limited Office 147, Centurion
House, London Road, Staines-upon-Thames, Surrey,
TW18 4AX

