

VEVOR[®]

TOUGH TOOLS, HALF PRICE

Technical Support and E-Warranty Certificate

www.vevor.com/support

TABLE SOCCER

MODEL:SUO-4824GW

We continue to be committed to provide you tools with competitive price.

"Save Half", "Half Price" or any other similar expressions used by us only represents an estimate of savings you might benefit from buying certain tools with us compared to the major top brands and does not necessarily mean to cover all categories of tools offered by us. You are kindly reminded to verify carefully when you are placing an order with us if you are actually saving half in comparison with the top major brands.

VEVOR[®]

TOUGH TOOLS, HALF PRICE

TABLE SOCCER

MODEL: SUO-4824GW

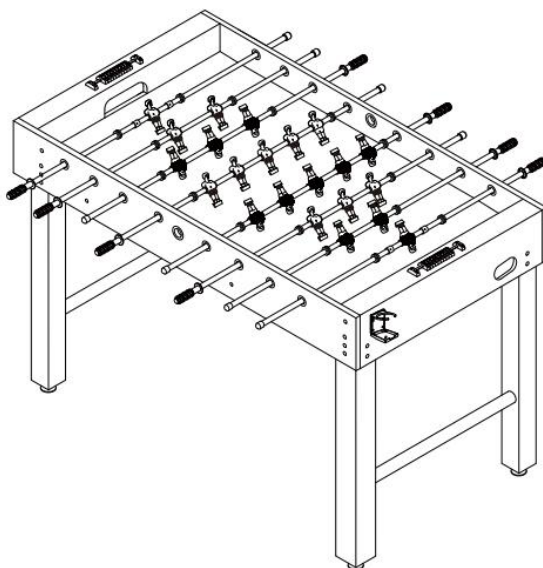

NEED HELP? CONTACT US!

Have product questions? Need technical support? Please feel free to contact us:

Technical Support and E-Warranty Certificate
www.vevor.com/support

This is the original instruction, please read all manual instructions carefully before operating. VEVOR reserves a clear interpretation of our user manual. The appearance of the product shall be subject to the product you received. Please forgive us that we won't inform you again if there are any technology or software updates on our product.



Warning-To reduce the risk of injury, user must read instructions manual carefully.

SAFETY WARNINGS AND PRECAUTIONS

Thank you for using this product. In order to make sure that you can operate the machine correctly, read this instruction carefully before operation and keep it properly for future reference. Please be sure to read the precautions and safety rules in this page to ensure your safe use. This manual will outline safety warnings and precautions, operating, maintenance. The warnings and instructions reviewed in this manual cannot cover all possible conditions and situations that may occur. Caution and common sense are not built into this product, since we believe that the uses will comply with these codes.

Please read ALL the instructions before using your machine.

1. Assemble needs to follow these instructions. Incorrect assembly can be a hazard.
2. Do not assemble when tired or when under the influence of alcohol, drugs or medication.
3. Weight and elastic and other product properties are only applicable to correctly and completely assembled products.
4. Keep the assembly area clean and well-lit.
5. Keep bystanders out of the area during assembly.
6. This is a equipment, not a toy, it needs to be used under the guidance of a professional. Do not allow children and pets to play alone or approach this item.
7. Use as intended only. Do not sit or stand on the product.
8. Inspect before every use. Do not use it if parts are loose or damaged.
9. Do not apply this unit to any other purposes than the indicated usage.
10. Do not use it for commercial purposes.
11. Do not clean it with any abrasive material.
12. Never leave it unattended while in use.
13. Pet urine and feces can damage the product, please keep away.

14. Do not place the product on or near hot air, electric burners or heaters.
 15. Young children should be supervised to ensure that they do not play with the product. Pets should stay away from the product.



















Do not use outdoors in rainy and cloudy days, avoid lightning strikes and falls. People or pets hanging on the product will cause injury or death.

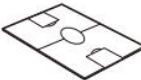

WARNING:Choking Hazard--Toy contains small balls and/or small parts.Not for children under 3 years.

IMPORTANT!Before attempting assembly please read through this instruction book to familiarize yourself with all the parts and assembly steps.We recommend that two adults assemble this game.Please refer to the Parts List below and be sure that all parts have been included.

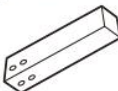
PARTS LIST

1 RUBBER SPACER  16 PCS	2 PLASTIC WASHER  16 PCS	3 RWA 3.5X35MM  4 PCS	4 BARREL NUT  4 PCS	5 WASHER  24 PCS
6 TM 6X40MM BOLT  24 PCS	7 FEET  4 PCS	8 FA 3.5X28MM  4 PCS	9 FA 3.5X12MM  8 PCS	10 END CAP  8 PCS
11 HANDLE  8 PCS	12 SOCCER BALL  2 PCS	13 CUP HOLDER  2 PCS	14 SCORER  2 PCS	15 SIDE PANEL  2 PCS
16 PLAYFIELD  1 PC	17 SUPPORT  2 PCS	18 END PANEL  2 PCS	19 LEG  4 PCS	20 LEG SUPPORT  2 PCS

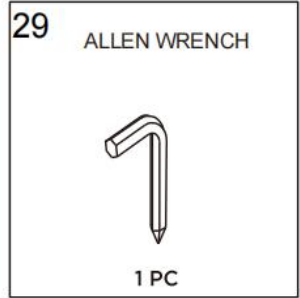
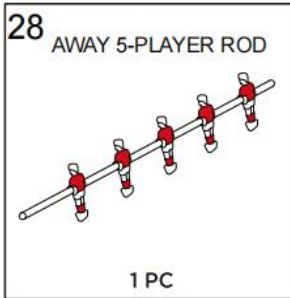
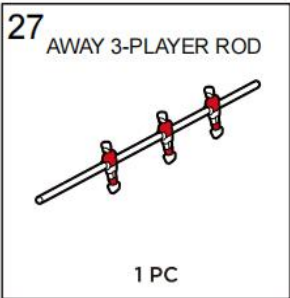
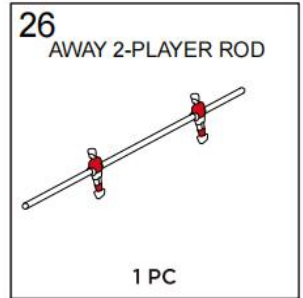
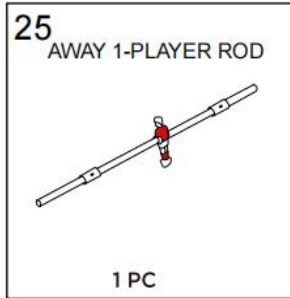
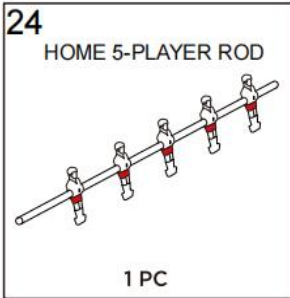
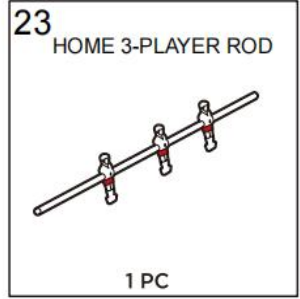
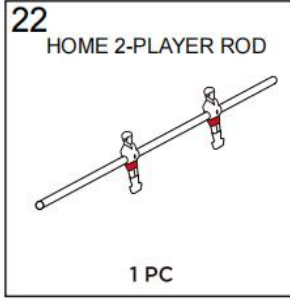
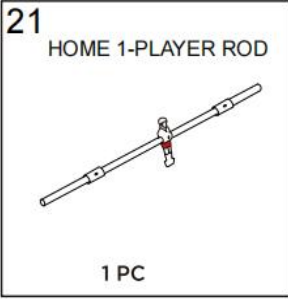

ASSEMBLY INSTRUCTIONS

STEP1:Place a part 15 side panel with the ball entry hole closer to the floor.Slide four part (21-24)home player rods with eight part 1 rubber spacers and eight part 2 plastio washers into the designated holes.

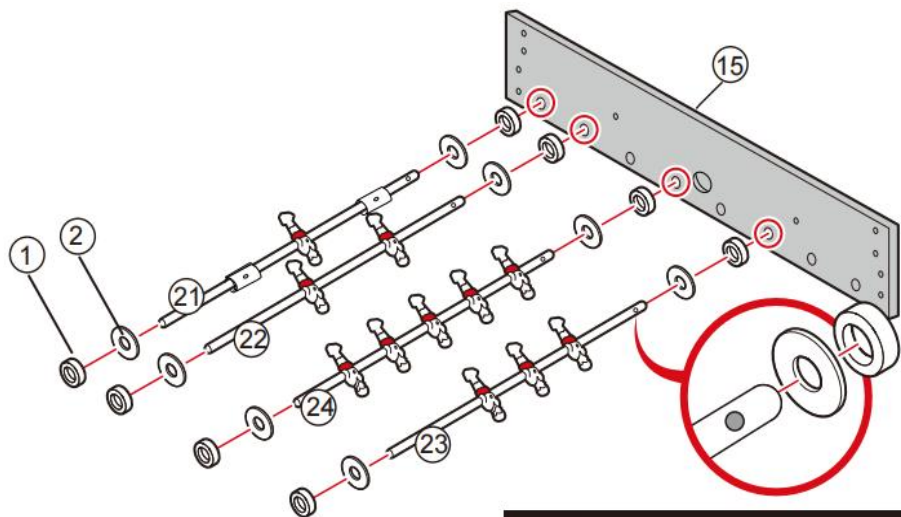

! Make sure that the ends with a hole are arranged on the same side.

STEP2: Slide four part (25-28) away player rods with eight part 1 rubber spacers and eight part 2 plastic washers in to the designated holes.

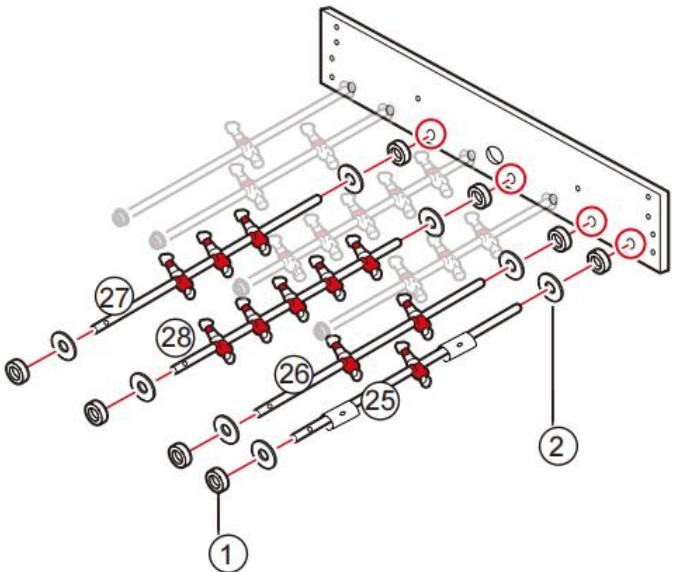

STEP3:Confirm that the rods are arranged correctly and the players on the same team face the same direction.

NOTE:The figures and table are upside down in this diagram.

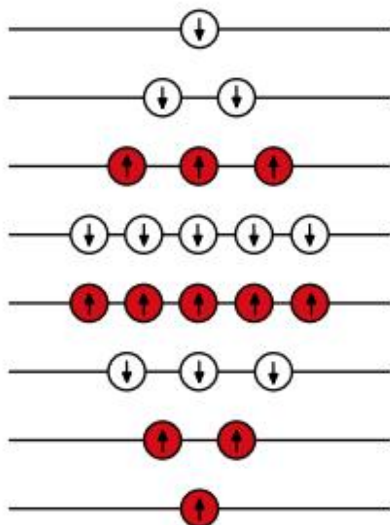

STEP4:Slide the other part 15 side panel onto the rods.

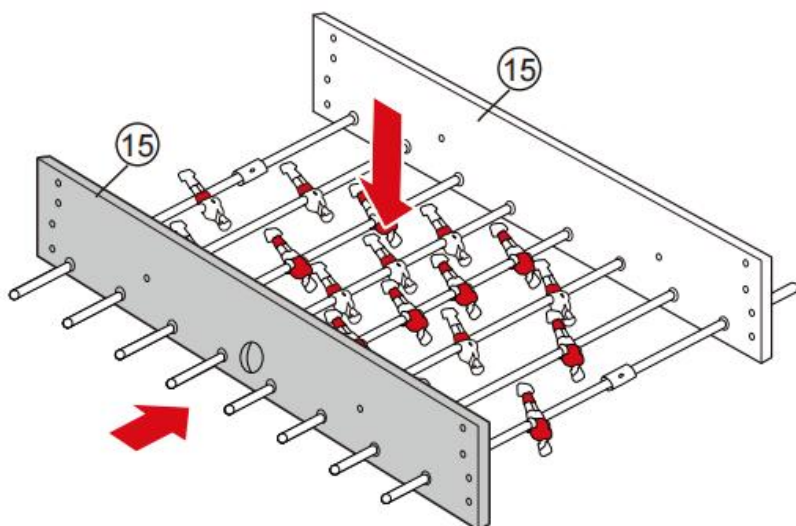

STEP5: Attach one part 18 end panel with four part 6 bolts and four part 5 washers. Flip the part 16 playfield upside down and slide it into the slots of the part 15 side panels.

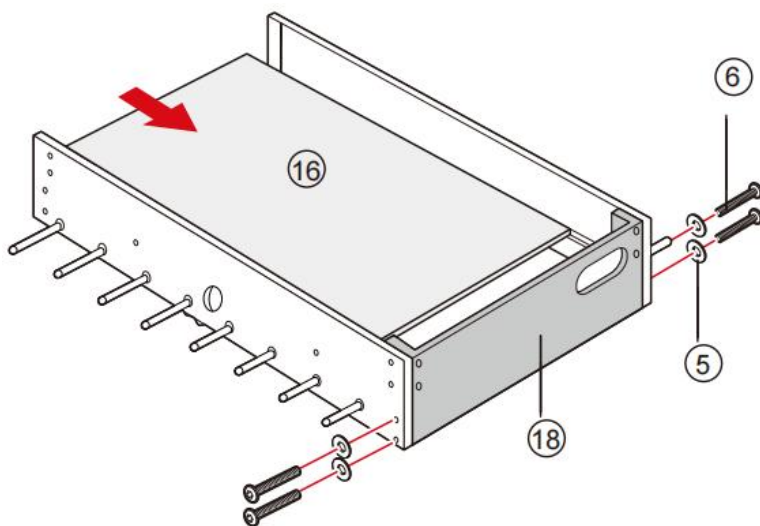

STEP6: Attach the other part 18 end panel with four part 6 bolts and four part 5 washers.

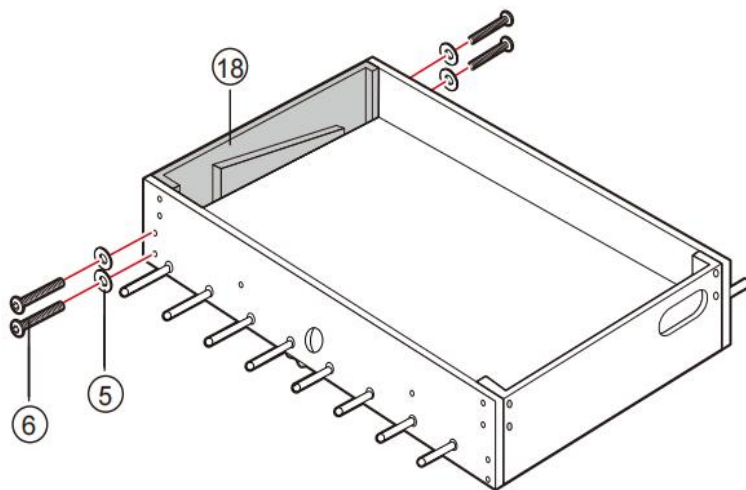

STEP7: Attach two part 17 supports with four part 3 screws and four part 4 nuts.

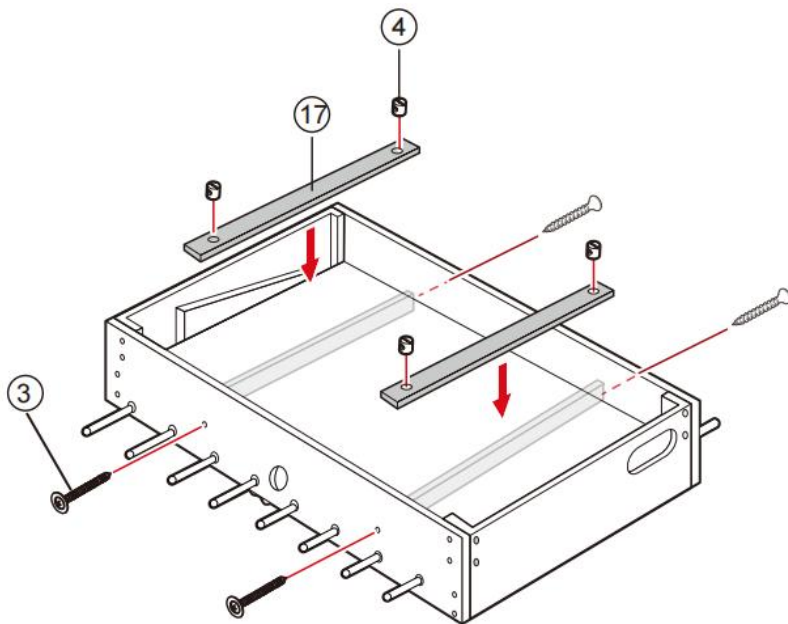

STEP8: Insert four part 19 legs into the corners. Place two part 20 support bars between the legs. Attach the legs with sixteen part 6 bolts and sixteen part 5 washers.

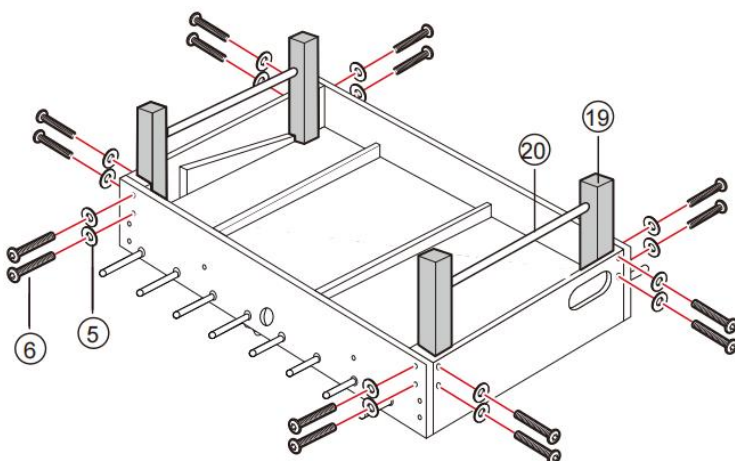

STEP9:Screw in four part 7 feet.

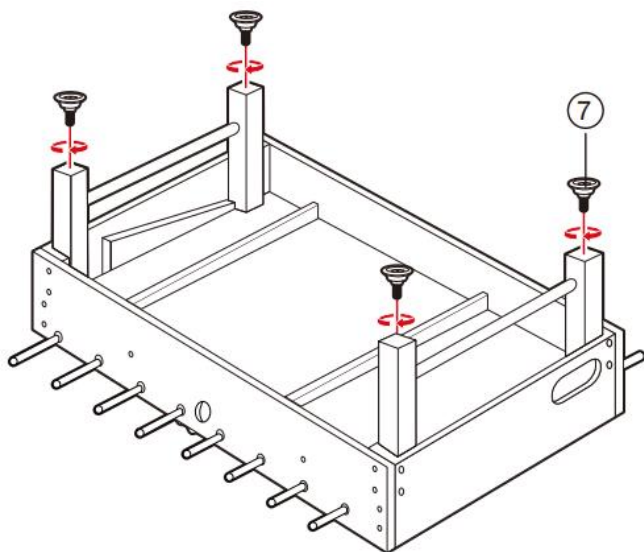

STEP10:Carefully flip the table over.

Attach two part 13 cup holders with eight part 9 screws.

NOTE:Do not lift the table while holding onto the rods.

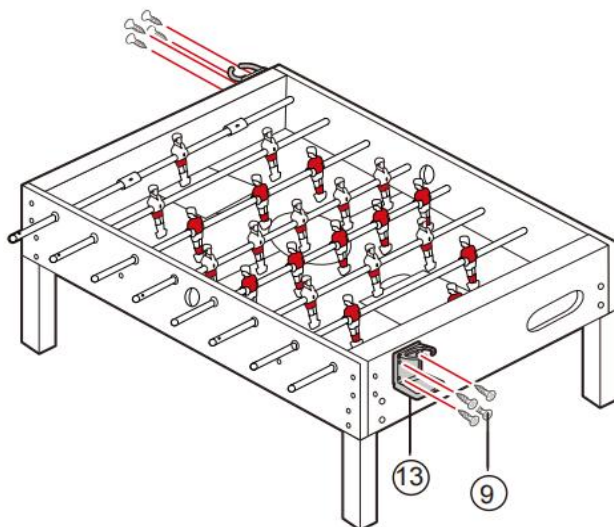

STEP11: Attach two part 14 scorers with four part 8 screws.

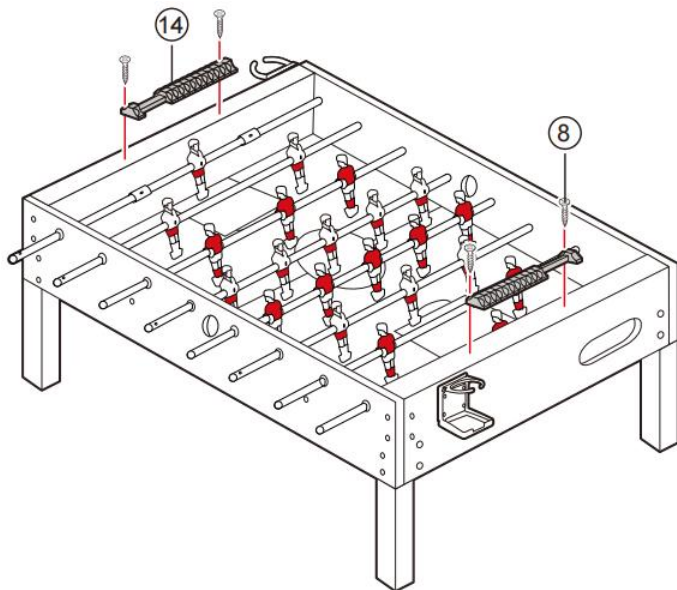

STEP12: Slide eight part 11 handles onto the ends of rods with a hole
Slide eight part 10 end caps onto the ends of rods without a hole.

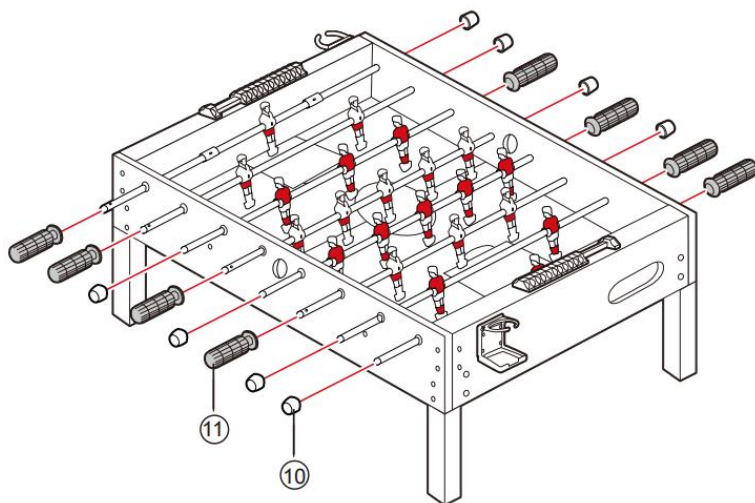

Manufacturer: Shanghaimuxinmuyeyouxiangongsi

Address: Baoshanqu Shuangchenglu 803long 11hao 1602A-1609shi
Shanghai

Imported to AUS: SIHAO PTY LTD, 1 ROKEVA STREETEASTWOOD
NSW 2122 Australia

Imported to USA: Sanven Technology Ltd.

Suite 250,9166 Anaheim Place, Rancho Cucamonga, CA 91730



SHUNSHUN GmbH

Römeräcker 9 Z2021,76351

Linkenheim-Hochstetten, Germany

euvertreter@gmail.com

+49 1727041930



Pooledas Group Ltd

Unit 5 Albert Edward House, The

Pavilions Preston, United Kingdom

pooledas123@gmail.com

Tel: 01772418127

Made In China

VEVOR[®]
TOUGH TOOLS, HALF PRICE

Technical Support and E-Warranty Certificate
www.vevor.com/support

VEVOR[®]

TOUGH TOOLS, HALF PRICE

Technisch Support- und E-Garantiezertifikat

www.vevor.com/support

TISCHFUSSBALL

MODELL : SUO-4824GW

We continue to be committed to provide you tools with competitive price.

"Save Half", "Half Price" or any other similar expressions used by us only represents an estimate of savings you might benefit from buying certain tools with us compared to the major top brands and does not necessarily mean to cover all categories of tools offered by us. You are kindly reminded to verify carefully when you are placing an order with us if you are actually saving half in comparison with the top major brands.

VEVOR[®]

TOUGH TOOLS, HALF PRICE

TABLE SOCCER

MODELL: SUO-4824GW

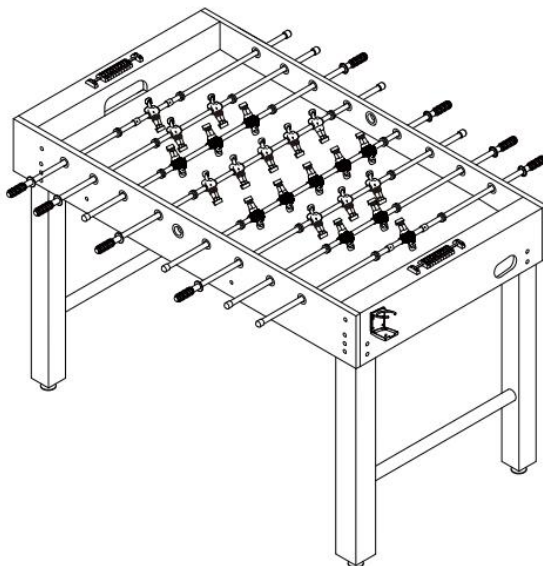

NEED HELP? CONTACT US!

Have product questions? Need technical support? Please feel free to contact us:

Technical Support and E-Warranty Certificate
www.vevor.com/support

This is the original instruction, please read all manual instructions carefully before operating. VEVOR reserves a clear interpretation of our user manual. The appearance of the product shall be subject to the product you received. Please forgive us that we won't inform you again if there are any technology or software updates on our product.



Warnung: Um das Verletzungsrisiko zu verringern, muss der Benutzer die Bedienungsanleitung sorgfältig lesen.

SAFETY WARNINGS AND PRECAUTIONS

Vielen Dank, dass Sie dieses Produkt verwenden . Um sicherzustellen, dass Sie die Maschine ordnungsgemäß bedienen können, lesen Sie diese Anleitung vor der Inbetriebnahme sorgfältig durch und bewahren Sie sie zum späteren Nachschlagen sorgfältig auf . Bitte lesen Sie unbedingt die Vorsichtsmaßnahmen und Sicherheitsregeln auf dieser Seite, um eine sichere Verwendung zu gewährleisten . In diesem Handbuch werden Sicherheitswarnungen und Vorsichtsmaßnahmen sowie Bedienung und Wartung beschrieben . Die in diesem Handbuch aufgeführten Warnungen und Anweisungen können nicht alle möglichen Bedingungen und Situationen abdecken, die auftreten können . Vorsicht und gesunder Menschenverstand sind in diesem Produkt nicht eingebaut, da wir davon ausgehen, dass die Verwendung diesen Codes entspricht .

Bitte lesen Sie ALLE Anweisungen, bevor Sie Ihr Gerät verwenden .

1. Beim Zusammenbau müssen diese Anweisungen befolgt werden. Eine falsche Montage kann eine Gefahr darstellen.
2. Montieren Sie das Gerät nicht, wenn Sie müde sind oder unter dem Einfluss von Alkohol, Drogen oder Medikamenten stehen.
3. Gewicht, Elastizität und sonstige Produkteigenschaften gelten nur für korrekt und vollständig montierte Produkte.
4. Halten Sie den Montagebereich sauber und gut beleuchtet.
5. Halten Sie während der Montage unbeteiligte Personen aus dem Bereich fern.
6. Dies ist ein Gerät, kein Spielzeug, es muss unter Anleitung eines Fachmanns verwendet werden. Erlauben Sie Kindern und Haustieren nicht, alleine zu spielen oder sich diesem Gegenstand zu nähern.
7. Nur bestimmungsgemäß verwenden. Setzen oder stehen Sie nicht auf dem Produkt.

8. Vor jedem Gebrauch prüfen. Benutzen Sie es nicht, wenn Teile lose oder beschädigt sind.

9. Benutzen Sie dieses Gerät nicht für andere Zwecke als den angegebenen.

10. Benutzen Sie es nicht für kommerzielle Zwecke.

11. Reinigen Sie es nicht mit scheuernden Materialien.

12. Lassen Sie es während des Gebrauchs niemals unbeaufsichtigt.

13. Urin und Kot von Haustieren können das Produkt beschädigen, bitte fernhalten.

14. Stellen Sie das Produkt nicht auf oder in die Nähe von Heißluft-, Elektrobrennern oder Heizgeräten.

15. Kleine Kinder sollten beaufsichtigt werden, um sicherzustellen, dass sie nicht mit dem Produkt spielen. Haustiere sollten vom Produkt ferngehalten werden.



















An regnerischen und bewölkten Tagen nicht im Freien verwenden, Blitzeinschläge und Stürze vermeiden. Am Produkt hängende Personen oder Haustiere können zu Verletzungen oder zum Tod führen.

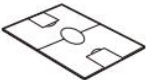

WARNUNG: Erstickungsgefahr – Spielzeug enthält kleine Kugeln und/oder Kleinteile. Nicht für Kinder unter 3 Jahren.

WICHTIG! Bevor Sie mit dem Zusammenbau beginnen, lesen Sie bitte diese Anleitung durch, um sich mit allen Teilen und Montageschritten vertraut zu machen. Wir empfehlen, dass zwei Erwachsene dieses Spiel zusammenbauen. Bitte sehen Sie sich die Teileliste unten an und stellen Sie sicher, dass alle Teile enthalten sind.

PARTS LIST

<p>1 RUBBER SPACER</p>  <p>16 PCS</p>	<p>2 PLASTIC WASHER</p>  <p>16 PCS</p>	<p>3 RWA 3.5X35MM</p>  <p>4 PCS</p>	<p>4 BARREL NUT</p>  <p>4 PCS</p>	<p>5 WASHER</p>  <p>24 PCS</p>
<p>6 TM 6X40MM BOLT</p>  <p>24 PCS</p>	<p>7 FEET</p>  <p>4 PCS</p>	<p>8 FA 3.5X28MM</p>  <p>4 PCS</p>	<p>9 FA 3.5X12MM</p>  <p>8 PCS</p>	<p>10 END CAP</p>  <p>8 PCS</p>
<p>11 HANDLE</p>  <p>8 PCS</p>	<p>12 SOCCER BALL</p>  <p>2 PCS</p>	<p>13 CUP HOLDER</p>  <p>2 PCS</p>	<p>14 SCORER</p>  <p>2 PCS</p>	<p>15 SIDE PANEL</p>  <p>2 PCS</p>
<p>16 PLAYFIELD</p>  <p>1 PC</p>	<p>17 SUPPORT</p>  <p>2 PCS</p>	<p>18 END PANEL</p>  <p>2 PCS</p>	<p>19 LEG</p>  <p>4 PCS</p>	<p>20 LEG SUPPORT</p>  <p>2 PCS</p>

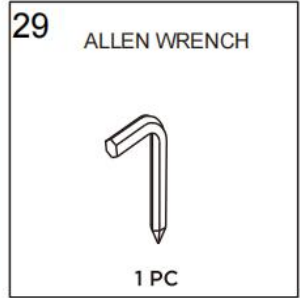
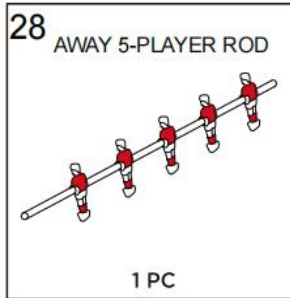
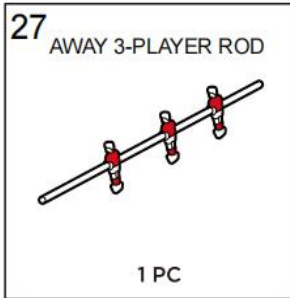
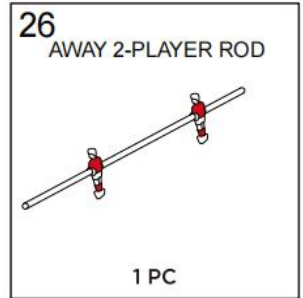
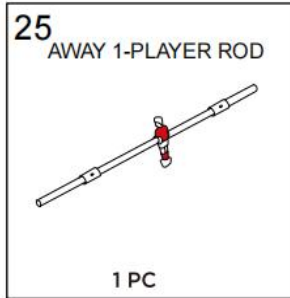
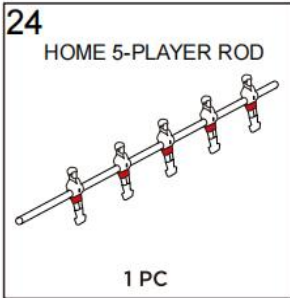
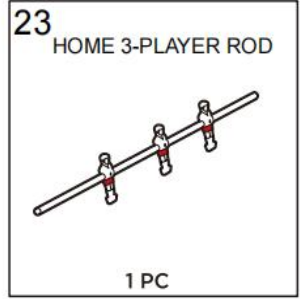
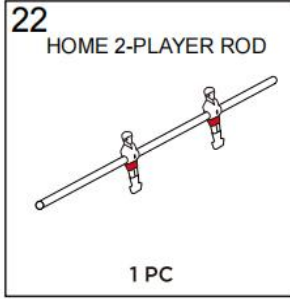
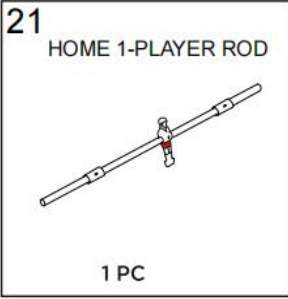

ASSEMBLY INSTRUCTIONS

SCHRITT 1: Platzieren Sie die Seitenwand Teil 15 mit dem Balleintrittsloch näher am Boden. Schieben Sie vier Heimspielerstangen Teil (21-24) mit acht Teil 1 Gummi-Abstandshalter und acht Teil 2 Plastico Unterlegscheiben in die dafür vorgesehenen Löcher stecken.

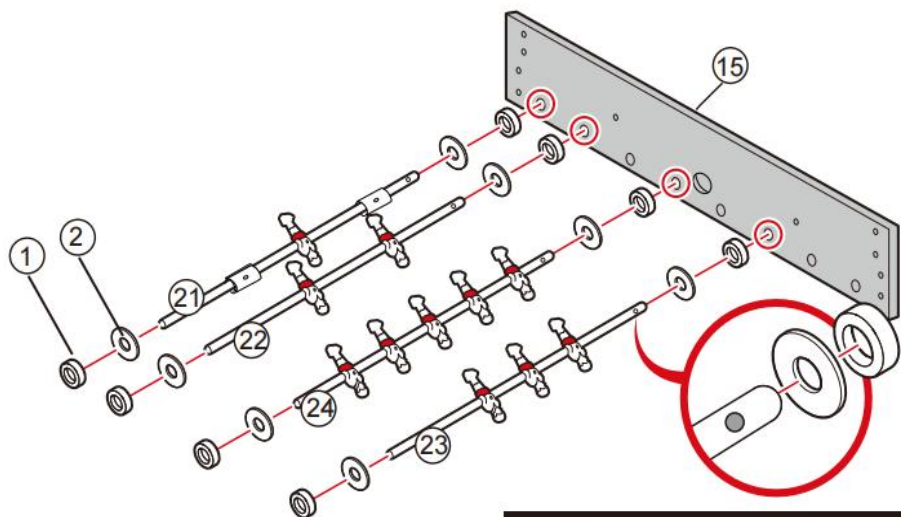

! Make sure that the ends with a hole are arranged on the same side.

SCHRITT 2: Schieben Sie die vierteiligen (25-28) Spielerstangen mit acht Teilen weg 1 Gummi-Abstandshalter und achteilige 2 Kunststoff-Unterlegscheiben zum festgelegt Löcher.

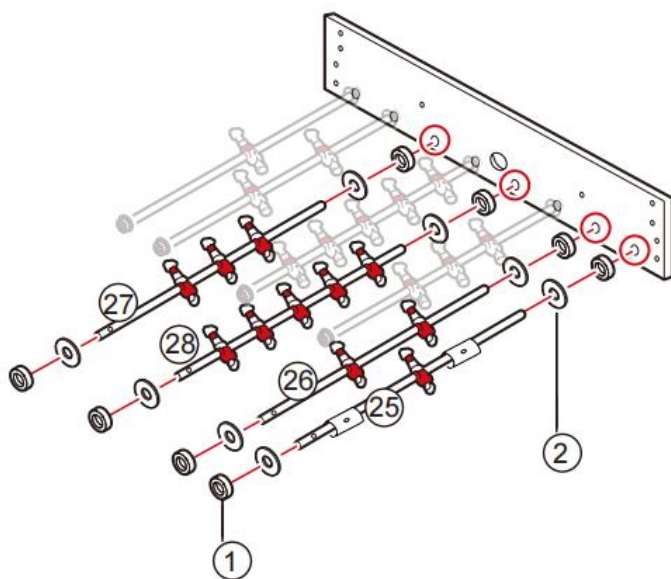

SCHRITT 3: Bestätigen Sie, dass die Stäbe richtig angeordnet sind und die Spieler auf der Das gleiche Team steht vor dem selbe Richtung.

HINWEIS: Die Zahlen und Der Tisch steht auf dem Kopf dieses Diagramm .

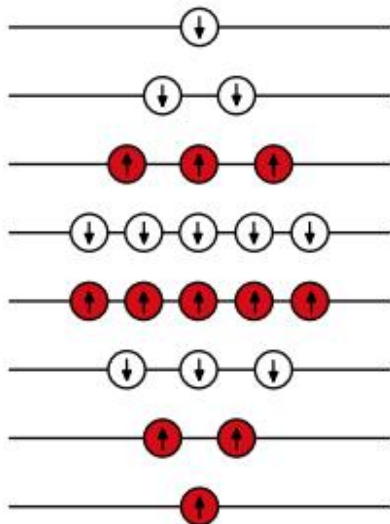

SCHRITT 4: Schieben Sie das andere Teil 15 der Seitenwand auf die Stangen.

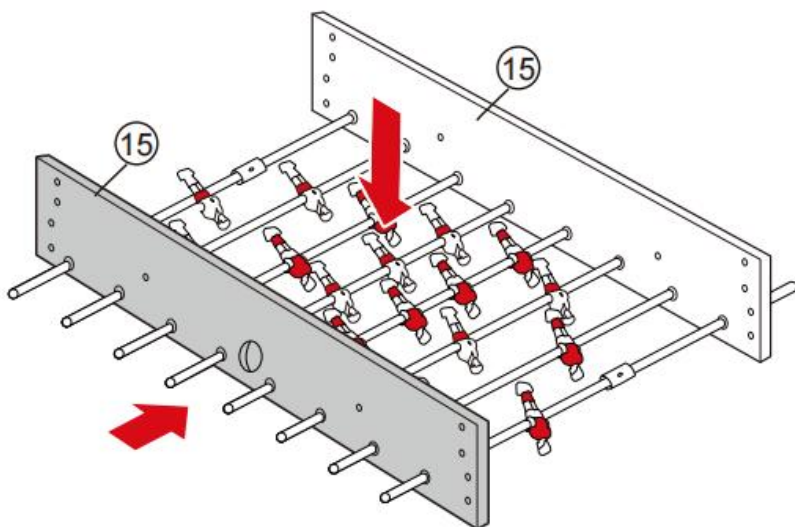

SCHRITT 5: Befestigen Sie eine Endplatte Teil 18 mit vier Schrauben Teil 6 und vier Unterlegscheiben Teil 5. Drehen Sie das Spielfeld Teil 16 um und schieben Sie es in die Schlitze der Seitenplatten Teil 15.

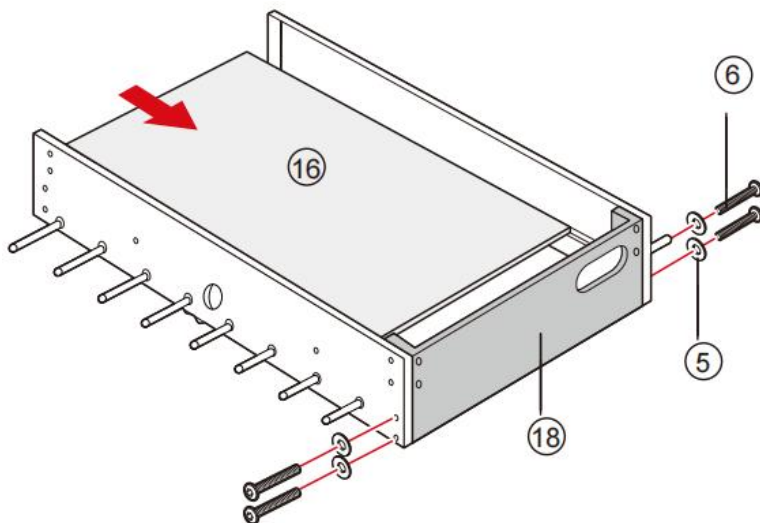

SCHRITT 6: Befestigen Sie die andere Endplatte (Teil 18) mit vier Schrauben (Teil 6) und vier Unterlegscheiben (Teil 5).

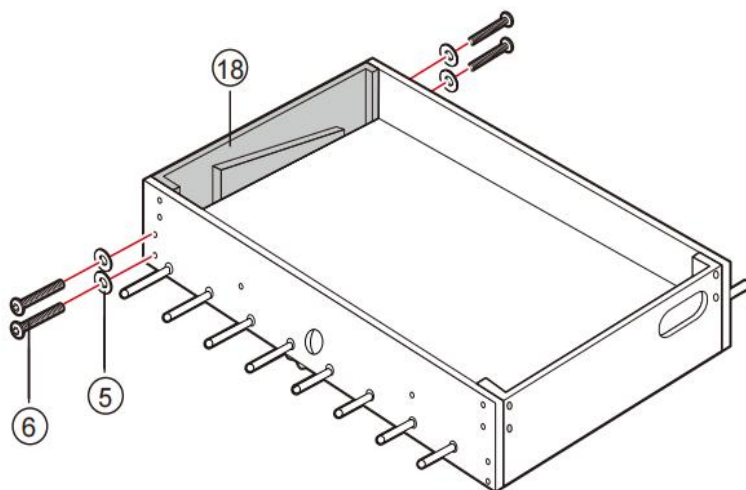

SCHRITT 7: Befestigen Sie zwei Stützen Teil 17 mit vier Schrauben Teil 3 und vier Muttern Teil 4.

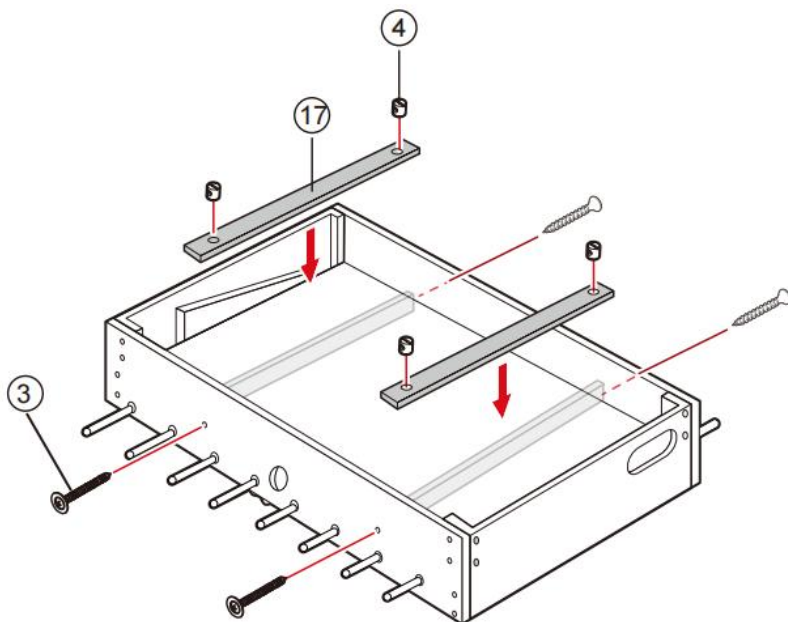

SCHRITT 8: Setzen Sie vier Teil 19-Beine in die Ecken ein. Platzieren Sie zwei Stützstangen Teil 20 zwischen den Beinen. Befestigen Sie die Beine mit sechzehn Schrauben (Teil 6) und sechzehn Unterlegscheiben (Teil 5).

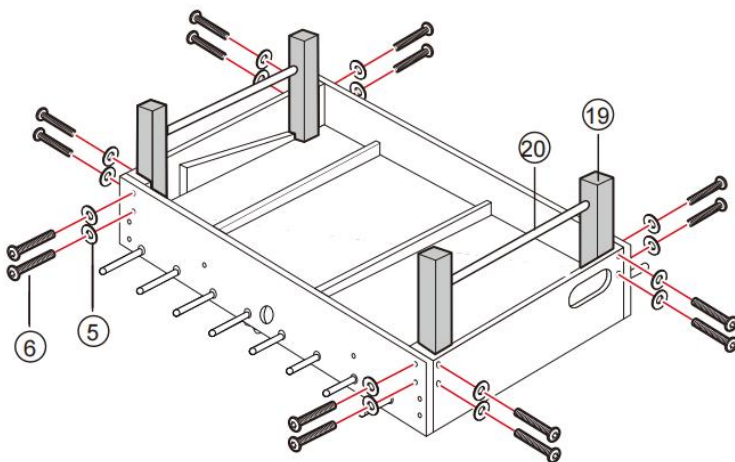

SCHRITT 9: Vier 7-Fuß-Teile einschrauben.

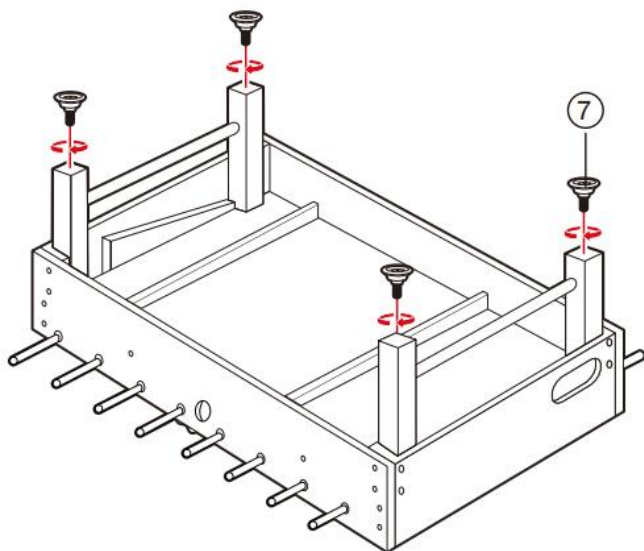

SCHRITT 10: Drehen Sie den Tisch vorsichtig um.

Befestigen Sie zwei Getränkehalter (Teil 13) mit acht Schrauben (Teil 9).

HINWEIS: Heben Sie den Tisch nicht an, während Sie ihn an den Stangen festhalten.

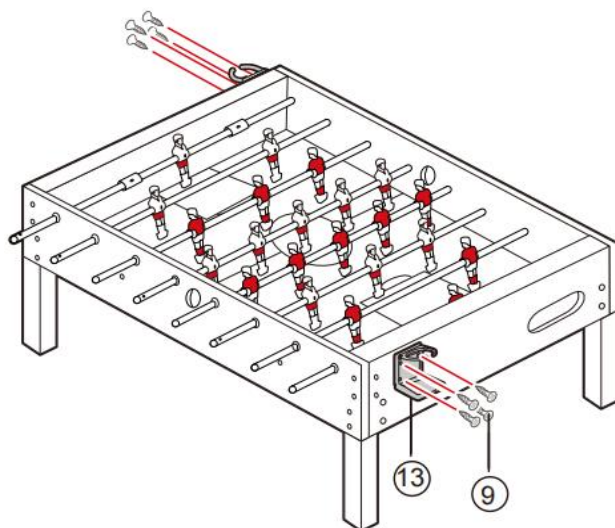

SCHRITT 11: Befestigen Sie zwei Kerben Teil 14 mit vier Schrauben Teil 8.

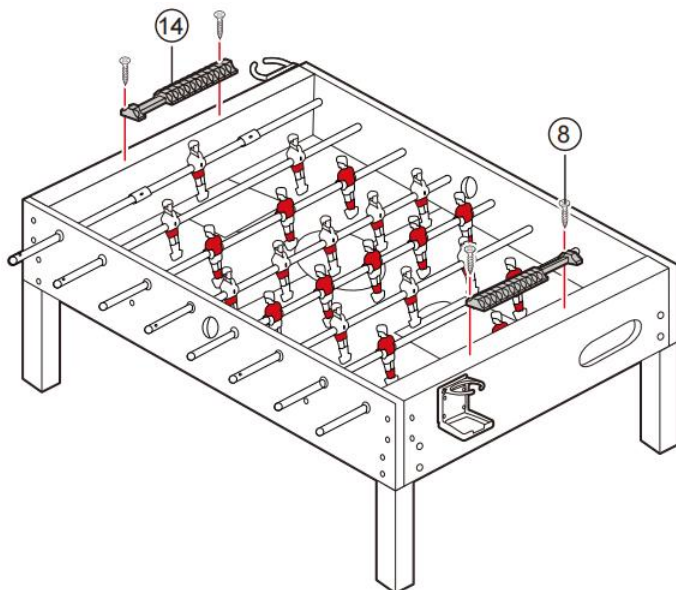

SCHRITT 12: Schieben Sie acht Griffe Teil 11 auf die Enden der Stangen mit einem Loch
Schieben Sie acht Endkappen Teil 10 auf die Enden der Stangen ohne Loch.

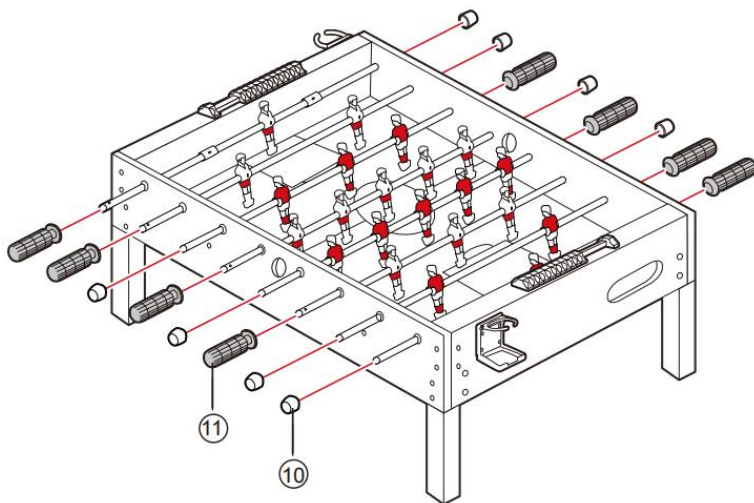

Hersteller: Shanghaimuxinmuyeyouxiangongsi

Adresse: Baoshanqu Shuangchenglu 803long 11hao 1602A-1609shi
Shanghai

Importiert nach AUS: SIHAO PTY LTD, 1 ROKEVA STREETEASTWOOD
NSW 2122 Australien

Importiert in die USA: Sanven Technology Ltd.

Suite 250 , 9166 Anaheim Place, Rancho Cucamonga, CA 91730

SHUNSHUN GmbH

Römeräcker 9 Z2021,76351

Linkenheim-Hochstetten, Germany

euvvertreter@gmail.com

EC

REP



Pooledas Group Ltd
Unit 5 Albert Edward House, The
Pavilions Preston, United Kingdom
pooledas123@gmail.com
Tel: 01772418127

In China hergestellt

VEVOR[®]
TOUGH TOOLS, HALF PRICE

Technisch Support- und E-Garantiezertifikat
www.vevor.com/support

VEVOR[®]

TOUGH TOOLS, HALF PRICE

Technique Assistance et certificat de garantie électronique

www.vevor.com/support

FOOTBALL DE TABLE

MODÈLE : SUO-4824GW

We continue to be committed to provide you tools with competitive price.

"Save Half", "Half Price" or any other similar expressions used by us only represents an estimate of savings you might benefit from buying certain tools with us compared to the major top brands and does not necessarily mean to cover all categories of tools offered by us. You are kindly reminded to verify carefully when you are placing an order with us if you are actually saving half in comparison with the top major brands.

VEVOR[®]

TOUGH TOOLS, HALF PRICE

TABLE SOCCER

MODÈLE: SUO-4824GW

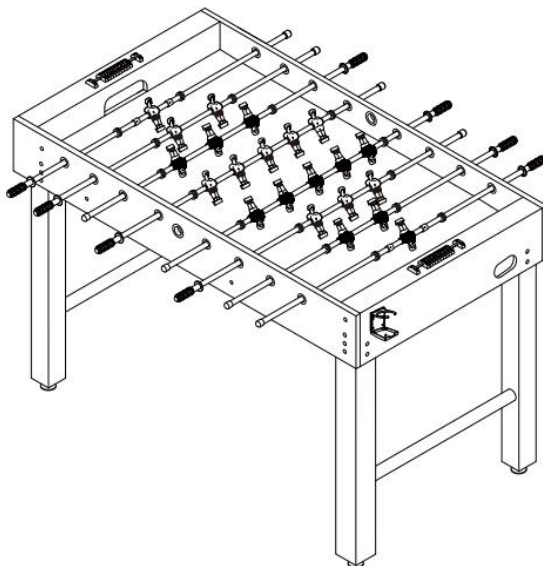

NEED HELP? CONTACT US!

Have product questions? Need technical support? Please feel free to contact us:

Technical Support and E-Warranty Certificate
www.vevor.com/support

This is the original instruction, please read all manual instructions carefully before operating. VEVOR reserves a clear interpretation of our user manual. The appearance of the product shall be subject to the product you received. Please forgive us that we won't inform you again if there are any technology or software updates on our product.



Avertissement : Pour réduire le risque de blessure, l'utilisateur doit lire attentivement le manuel d'instructions.

SAFETY WARNINGS AND PRECAUTIONS

Merci d'avoir utilisé ce produit . Afin de vous assurer que vous pouvez utiliser la machine correctement, lisez attentivement ces instructions avant de l'utiliser et conservez-les correctement pour référence future . Veuillez vous assurer de lire les précautions et les règles de sécurité contenues dans cette page pour garantir votre utilisation en toute sécurité . Ce manuel décrit les avertissements et les précautions de sécurité, le fonctionnement et la maintenance . Les avertissements et instructions examinés dans ce manuel ne peuvent pas couvrir toutes les conditions et situations possibles qui peuvent survenir . La prudence et le bon sens ne sont pas intégrés à ce produit, car nous pensons que les utilisations seront conformes à ces codes .

Veillez lire TOUTES les instructions avant d'utiliser votre machine .

1. L'assemblage doit suivre ces instructions. Un montage incorrect peut constituer un danger.
2. Ne vous rassemblez pas lorsque vous êtes fatigué ou sous l'influence de l'alcool, de drogues ou de médicaments.
3. Le poids, l'élasticité et les autres propriétés du produit ne s'appliquent qu'aux produits correctement et complètement assemblés.
4. Gardez la zone de montage propre et bien éclairée.
5. Gardez les spectateurs hors de la zone pendant l'assemblage.
6. Il s'agit d'un équipement et non d'un jouet, il doit être utilisé sous la direction d'un professionnel. Ne laissez pas les enfants et les animaux domestiques jouer seuls ou s'approcher de cet article.
7. Utiliser uniquement comme prévu. Ne vous asseyez pas et ne vous tenez pas debout sur le produit.
8. Inspectez avant chaque utilisation. Ne l'utilisez pas si les pièces sont desserrées ou endommagées.
- 9 . N'utilisez pas cet appareil à d'autres fins que celles indiquées .

dix . _ Ne l'utilisez pas à des fins commerciales .

1 1 . Ne le nettoyez pas avec un matériau abrasif .

1 2 . Ne le laissez jamais sans surveillance pendant son utilisation .

1 3 . L'urine et les excréments d'animaux peuvent endommager le produit, veuillez le tenir à l'écart .

1 4 . Ne placez pas le produit sur ou à proximité d'air chaud, de brûleurs électriques ou de radiateurs .

15 . Les jeunes enfants doivent être surveillés pour s'assurer qu'ils ne jouent pas avec le produit . Les animaux domestiques doivent rester à l'écart du produit.



















Ne pas utiliser à l'extérieur par temps pluvieux et nuageux, évitez les coups de foudre et les chutes . Les personnes ou les animaux domestiques accrochés au produit provoqueront des blessures, voire la mort .

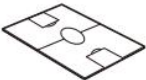

AVERTISSEMENT : Risque d'étouffement - Le jouet contient de petites balles et/ou de petites pièces. Ne convient pas aux enfants de moins de 3 ans.

IMPORTANT! Avant de tenter l'assemblage, veuillez lire ce manuel d'instructions pour vous familiariser avec toutes les pièces et étapes d'assemblage. Nous recommandons que deux adultes assemblent ce jeu. Veuillez vous référer à la liste des pièces ci-dessous et assurez-vous que toutes les pièces ont été incluses.

PARTS LIST

<p>1 RUBBER SPACER</p>  <p>16 PCS</p>	<p>2 PLASTIC WASHER</p>  <p>16 PCS</p>	<p>3 RWA 3.5X35MM</p>  <p>4 PCS</p>	<p>4 BARREL NUT</p>  <p>4 PCS</p>	<p>5 WASHER</p>  <p>24 PCS</p>
<p>6 TM 6X40MM BOLT</p>  <p>24 PCS</p>	<p>7 FEET</p>  <p>4 PCS</p>	<p>8 FA 3.5X28MM</p>  <p>4 PCS</p>	<p>9 FA 3.5X12MM</p>  <p>8 PCS</p>	<p>10 END CAP</p>  <p>8 PCS</p>
<p>11 HANDLE</p>  <p>8 PCS</p>	<p>12 SOCCER BALL</p>  <p>2 PCS</p>	<p>13 CUP HOLDER</p>  <p>2 PCS</p>	<p>14 SCORER</p>  <p>2 PCS</p>	<p>15 SIDE PANEL</p>  <p>2 PCS</p>
<p>16 PLAYFIELD</p>  <p>1 PC</p>	<p>17 SUPPORT</p>  <p>2 PCS</p>	<p>18 END PANEL</p>  <p>2 PCS</p>	<p>19 LEG</p>  <p>4 PCS</p>	<p>20 LEG SUPPORT</p>  <p>2 PCS</p>

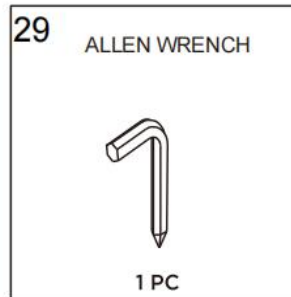
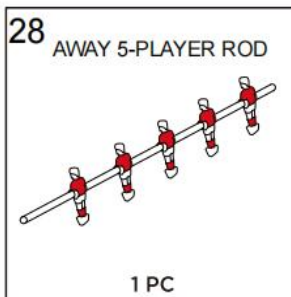
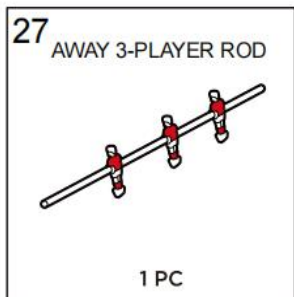
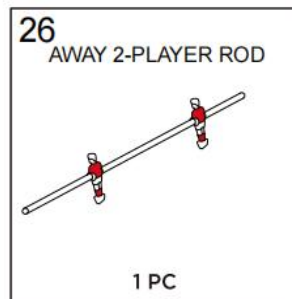
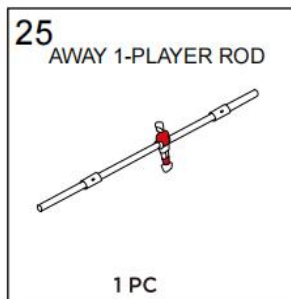
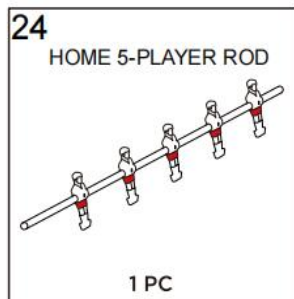
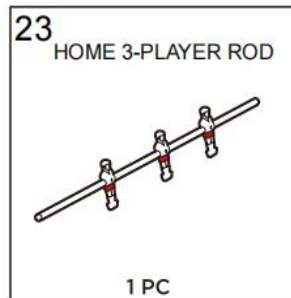
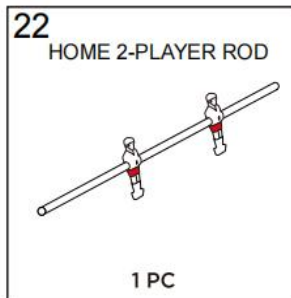
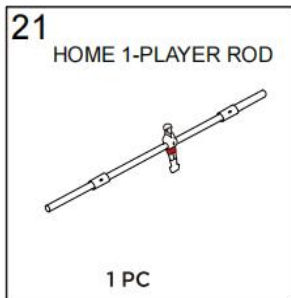

ASSEMBLY INSTRUCTIONS

ÉTAPE 1 : Placez un panneau latéral de la pièce 15 avec le trou d'entrée de la balle plus près du sol. Faites glisser les tiges du joueur à domicile en quatre parties (21-24) avec huit pièces 1. entretoises en caoutchouc et huit parties 2 plastio rondelles dans les trous désignés.

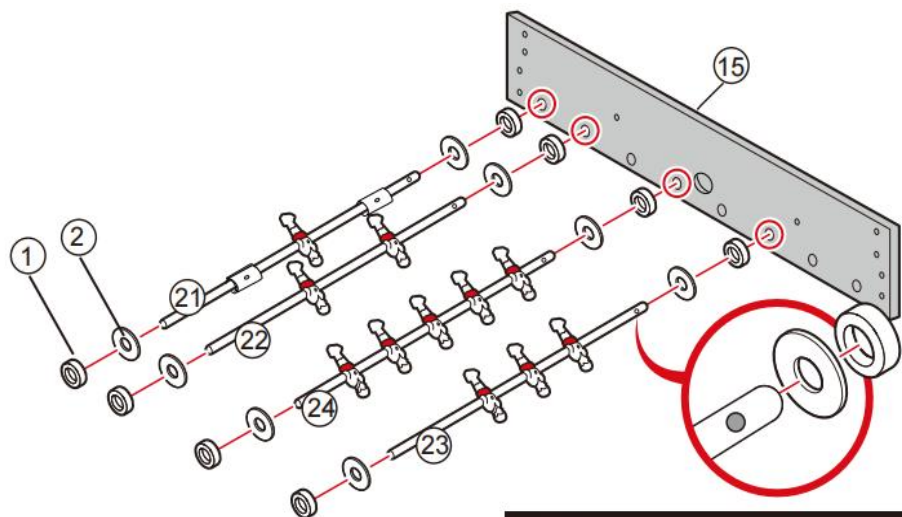

! Make sure that the ends with a hole are arranged on the same side.

ÉTAPE 2 : Faites glisser les tiges de joueur en quatre parties (25-28) avec huit parties 1 entretoises en caoutchouc et huit rondelles en plastique partie 2 au désigné des trous.

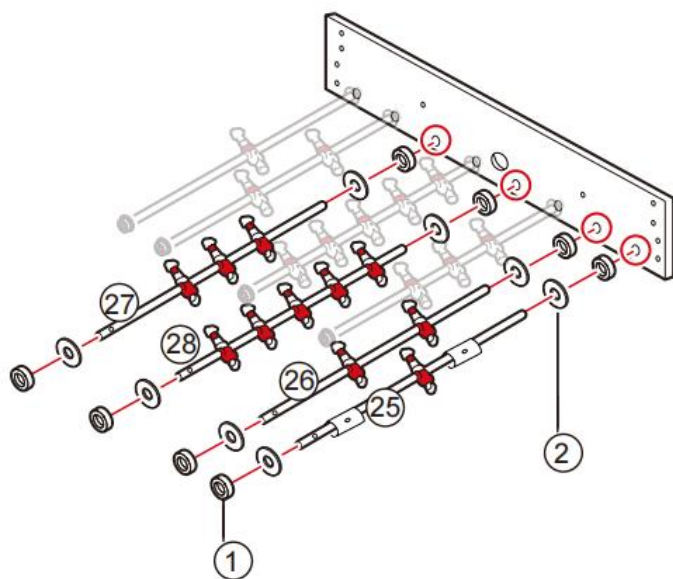

ÉTAPE 3 : Confirmez que les tiges sont disposés correctement et les joueurs sur le la même équipe affronte le Même direction.

REMARQUE : Les chiffres et la table est à l'envers ce schéma .

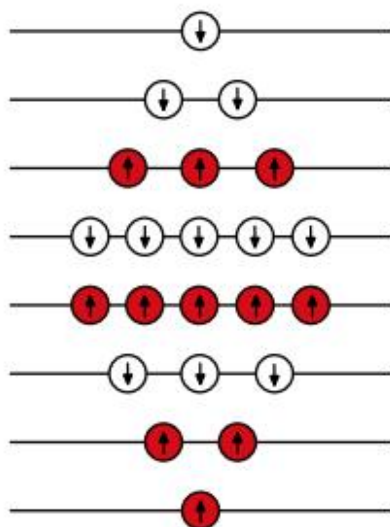

ÉTAPE 4 : Faites glisser l'autre partie 15 du panneau latéral sur les tiges.

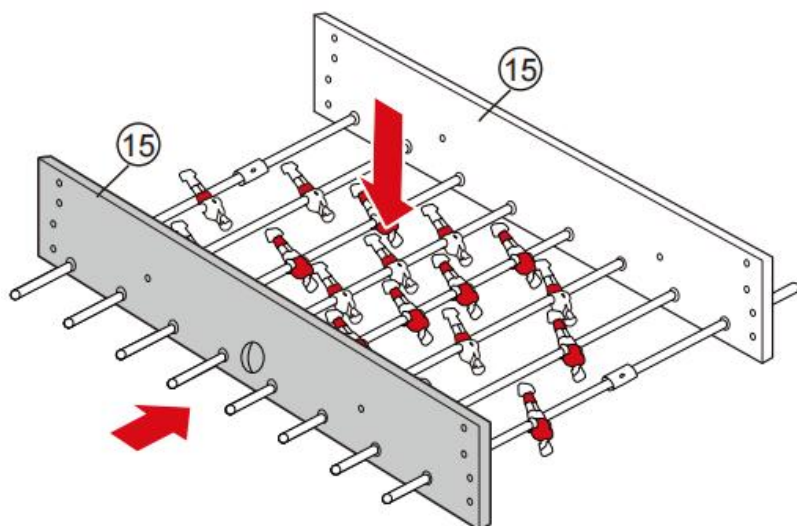

ÉTAPE 5 : Fixez un panneau d'extrémité de la pièce 18 avec quatre boulons de la pièce 6 et quatre rondelles de la pièce 5. Retournez le plateau de jeu de la pièce 16 à l'envers et faites-le glisser dans les fentes des panneaux latéraux de la pièce 15.

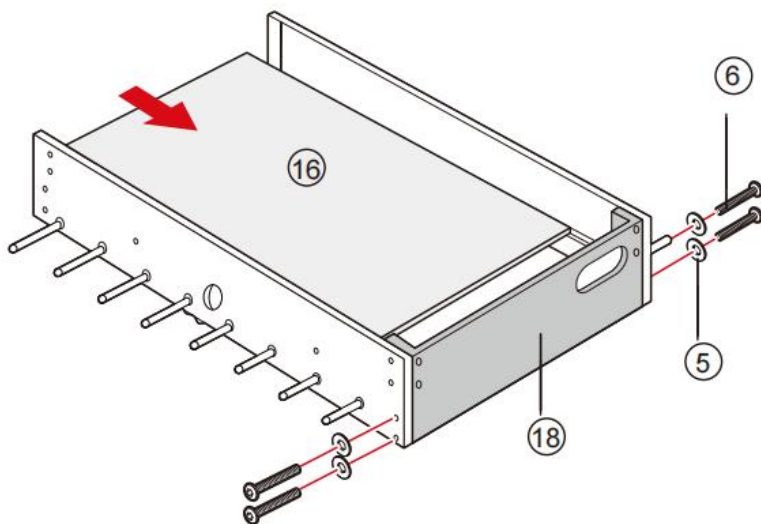

ÉTAPE 6 : Fixez l'autre panneau d'extrémité de la pièce 18 avec quatre boulons de la pièce 6 et quatre rondelles de la pièce 5.

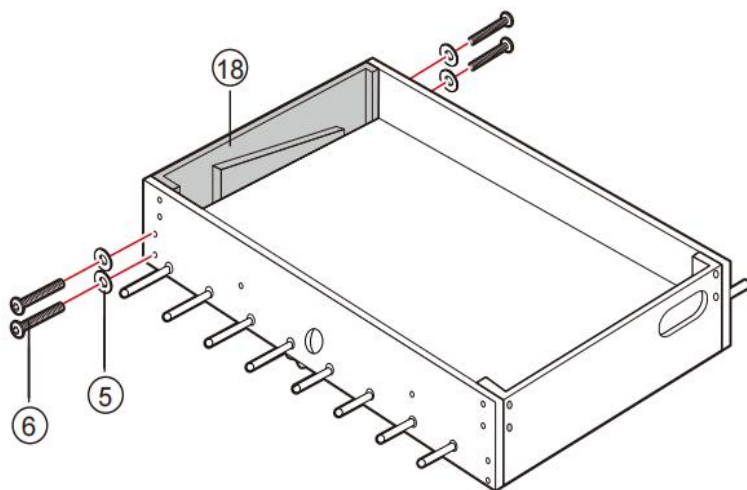

ÉTAPE 7 : Fixez deux supports de partie 17 avec quatre vis de partie 3 et quatre écrous de partie 4.

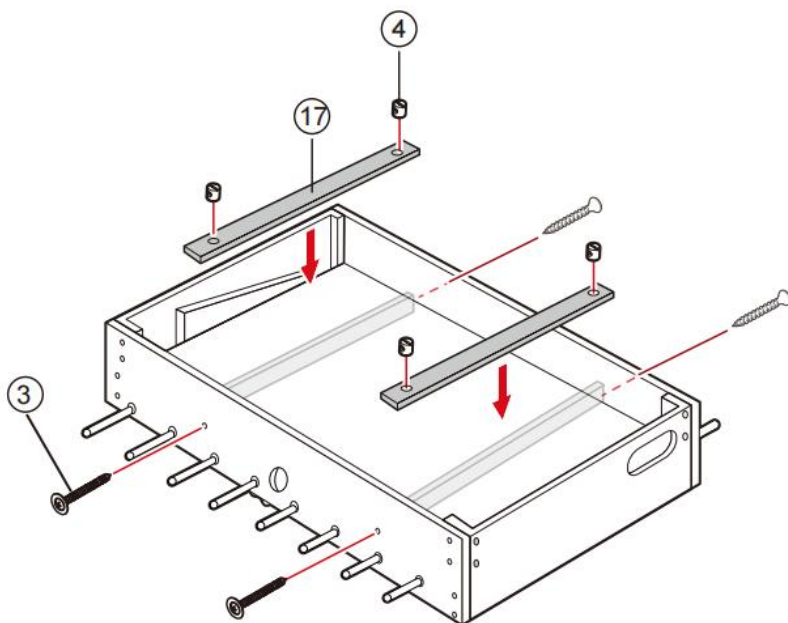

ÉTAPE 8 : Insérez quatre pieds de la partie 19 dans les coins. Placez deux barres de support partie 20 entre les jambes. Fixez les pieds avec seize boulons partie 6 et seize rondelles partie 5.

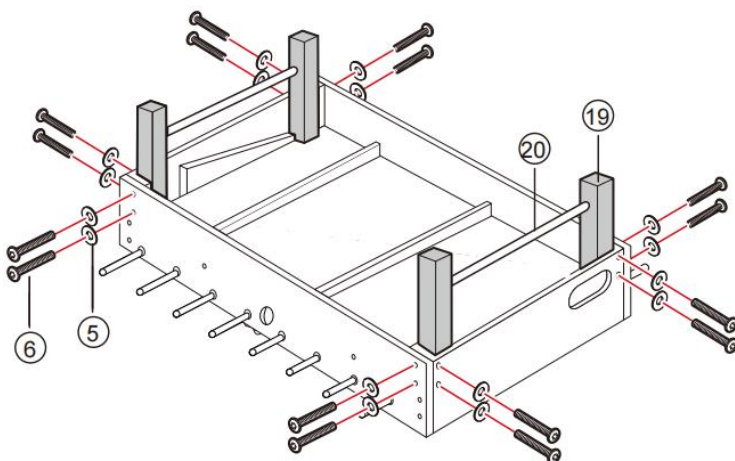

ÉTAPE 9 : Vissez quatre parties de 7 pieds.

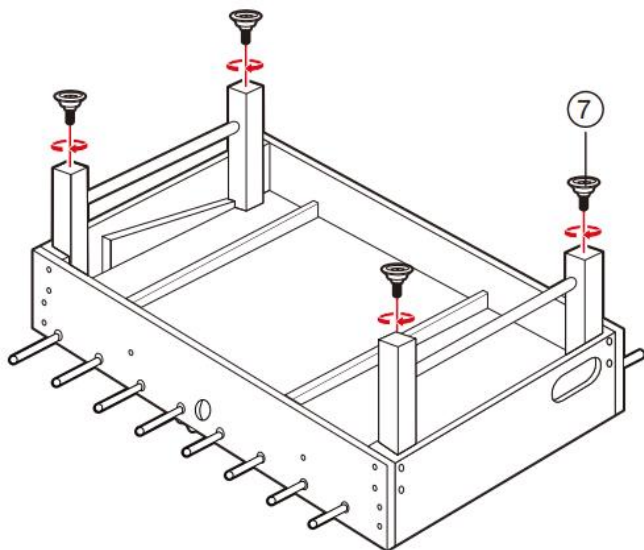

ÉTAPE 10 : Retournez soigneusement la table.

Fixez deux porte-gobelets en partie 13 avec huit vis en partie 9.

REMARQUE : Ne soulevez pas la table tout en tenant les tiges.

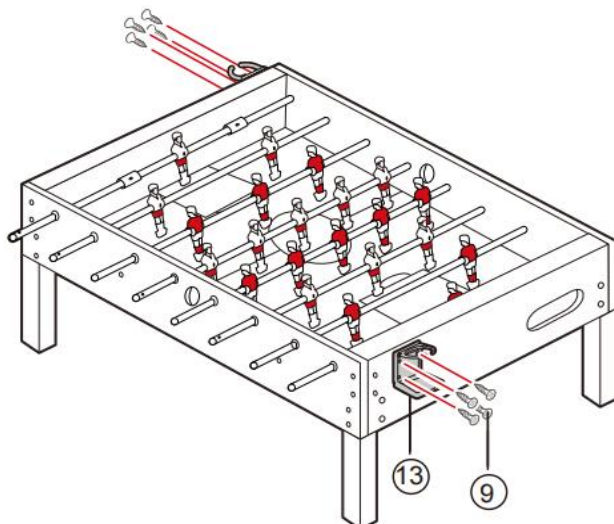

ÉTAPE 11 : Fixez deux marqueurs en partie 14 avec quatre vis en partie 8.

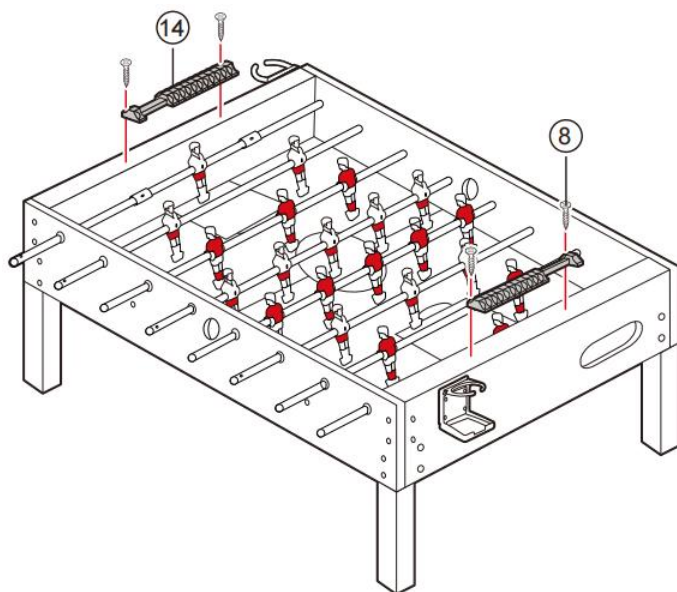

ÉTAPE 12 : Glissez huit poignées de la partie 11 sur les extrémités des tiges avec un trou

Faites glisser huit embouts de 10 parties sur les extrémités des tiges sans trou.

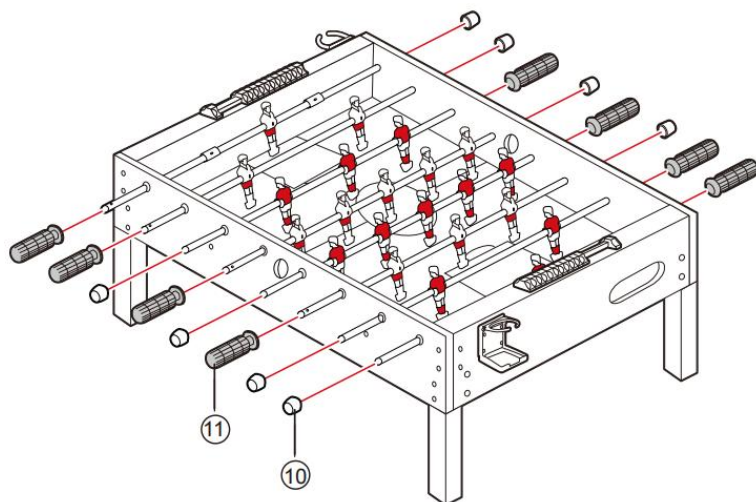

Fabricant : Shanghaimuxinmuyeyouxiangongsi

Adresse : Baoshanqu Shuangchenglu 803long 11hao 1602A-1609shi
Shanghai

Importé en Australie : SIHAO PTY LTD, 1 ROKEVA STREETASTWOOD
NSW 2122 Australie

Importé aux États-Unis : Sanven Technology Ltd.
Suite 250 , 9166 Anaheim Place, Rancho Cucamonga, CA 91730



SHUNSHUN GmbH
Römeräcker 9 Z2021,76351
Linkenheim-Hochstetten, Germany
euvertreter@gmail.com
+49 1727041930



Pooledas Group Ltd
Unit 5 Albert Edward House, The
Pavilions Preston, United Kingdom
pooledas123@gmail.com
Tel: 01772418127

Fabriqué en Chine

VEVOR[®]

TOUGH TOOLS, HALF PRICE

Technique Assistance et certificat de garantie électronique

www.vevor.com/support

VEVOR[®]

TOUGH TOOLS, HALF PRICE

Techniczny Certyfikat wsparcia i e-gwarancji

www.vevor.com/support

PIŁKA NOŻNA

MODEL : SUO-4824GW

We continue to be committed to provide you tools with competitive price.

"Save Half", "Half Price" or any other similar expressions used by us only represents an estimate of savings you might benefit from buying certain tools with us compared to the major top brands and does not necessarily mean to cover all categories of tools offered by us. You

are kindly reminded to verify carefully when you are placing an order with us if you are actually saving half in comparison with the top major brands.

VEVOR[®]

TOUGH TOOLS, HALF PRICE

TABLE SOCCER

MODEL: SUO-4824GW

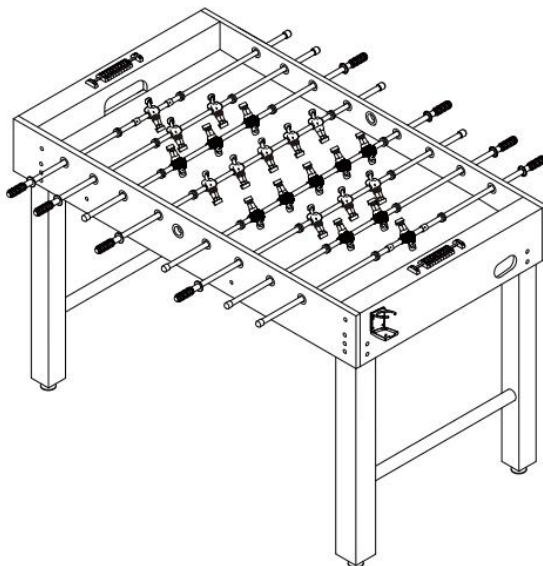

NEED HELP? CONTACT US!

Have product questions? Need technical support? Please feel free to contact us:

Technical Support and E-Warranty Certificate
www.vevor.com/support

This is the original instruction, please read all manual instructions carefully before operating. VEVOR reserves a clear interpretation of our user manual. The appearance of the product shall be subject to the product you received. Please forgive us that we won't inform you again if there are any technology or software updates on our product.



Ostrzeżenie — aby zmniejszyć ryzyko obrażeń, użytkownik musi uważnie przeczytać instrukcję obsługi.

SAFETY WARNINGS AND PRECAUTIONS

Dziękujemy za korzystanie z tego produktu . Aby mieć pewność, że będziesz mógł prawidłowo obsługiwać maszynę, przeczytaj uważnie niniejszą instrukcję przed rozpoczęciem użytkowania i zachowaj ją odpowiednio do wykorzystania w przyszłości . Aby zapewnić bezpieczne użytkowanie, pamiętaj o zapoznaniu się ze środkami ostrożności i zasadami bezpieczeństwa zawartymi na tej stronie . Niniejsza instrukcja zawiera ostrzeżenia i środki ostrożności dotyczące bezpieczeństwa, obsługi i konserwacji . Ostrzeżenia i instrukcje omówione w tej instrukcji nie obejmują wszystkich możliwych warunków i sytuacji, które mogą wystąpić . Ostrożność i zdrowy rozsądek nie są podstawą tego produktu, ponieważ wierzymy, że jego zastosowanie będzie zgodne z tymi kodami .

Przed użyciem urządzenia przeczytaj WSZYSTKIE instrukcje .

1. Montaż musi przebiegać zgodnie z poniższymi instrukcjami. Nieprawidłowy montaż może stanowić zagrożenie.
2. Nie montuj się będąc zmęczonym, pod wpływem alkoholu, narkotyków lub leków.
3. Waga, elastyczność i inne właściwości produktu mają zastosowanie wyłącznie do produktów prawidłowo i całkowicie zmontowanych.
4. Utrzymuj miejsce zbiórki w czystości i dobrze oświetlone.
5. Podczas montażu trzymaj osoby postronne z dala od obszaru.
6. To jest sprzęt, a nie zabawka, należy go używać pod okiem profesjonalisty. Nie pozwalaj dzieciom i zwierzętom bawić się samotnie ani nie zbliżaj się do tego przedmiotu.
7. Używaj wyłącznie zgodnie z przeznaczeniem. Nie siadaj ani nie stawaj na produkcie.
8. Sprawdź przed każdym użyciem. Nie używaj go, jeśli części są luźne lub uszkodzone.
- 9 . Nie używaj tego urządzenia do celów innych niż wskazane .



















- 1 0 . Nie używaj go do celów komercyjnych .
- 1 1 . Nie czyść go żadnymi materiałami ściernymi .
- 1 2 . Nigdy nie pozostawiaj go bez nadzoru podczas użytkowania .
- 1 3 . Mocz i odchody zwierząt domowych mogą uszkodzić produkt, należy je trzymać z daleka .
- 1 4 . Nie umieszczaj produktu na lub w pobliżu gorącego powietrza, palników elektrycznych lub grzejników .
- 15 . Małe dzieci należy nadzorować, aby mieć pewność, że nie bawią się produktem . Zwierzęta powinny trzymać się z daleka od produktu. Nie używać na zewnątrz w deszczowe i pochmurne dni, unikać uderzeń pioruna i upadków . Osoby lub zwierzęta wiszące na produkcie mogą spowodować obrażenia lub śmierć .

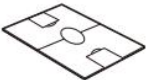

OSTRZEŻENIE: Ryzyko zadławienia — zabawka zawiera małe kulki i/lub małe części. Nie przeznaczona dla dzieci poniżej 3 lat.

WAŻNY! Przed przystąpieniem do montażu przeczytaj tę instrukcję, aby zapoznać się ze wszystkimi częściami i etapami montażu. Zalecamy, aby grę składały dwie osoby dorosłe. Zapoznaj się z poniższą listą części i upewnij się, że wszystkie części zostały dołączone.

PARTS LIST

<p>1 RUBBER SPACER</p>  <p>16 PCS</p>	<p>2 PLASTIC WASHER</p>  <p>16 PCS</p>	<p>3 RWA 3.5X35MM</p>  <p>4 PCS</p>	<p>4 BARREL NUT</p>  <p>4 PCS</p>	<p>5 WASHER</p>  <p>24 PCS</p>
<p>6 TM 6X40MM BOLT</p>  <p>24 PCS</p>	<p>7 FEET</p>  <p>4 PCS</p>	<p>8 FA 3.5X28MM</p>  <p>4 PCS</p>	<p>9 FA 3.5X12MM</p>  <p>8 PCS</p>	<p>10 END CAP</p>  <p>8 PCS</p>
<p>11 HANDLE</p>  <p>8 PCS</p>	<p>12 SOCCER BALL</p>  <p>2 PCS</p>	<p>13 CUP HOLDER</p>  <p>2 PCS</p>	<p>14 SCORER</p>  <p>2 PCS</p>	<p>15 SIDE PANEL</p>  <p>2 PCS</p>
<p>16 PLAYFIELD</p>  <p>1 PC</p>	<p>17 SUPPORT</p>  <p>2 PCS</p>	<p>18 END PANEL</p>  <p>2 PCS</p>	<p>19 LEG</p>  <p>4 PCS</p>	<p>20 LEG SUPPORT</p>  <p>2 PCS</p>

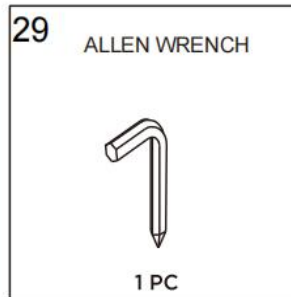
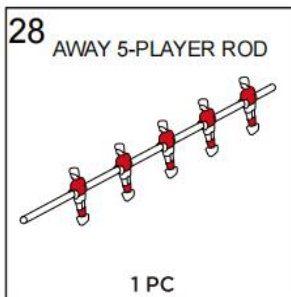
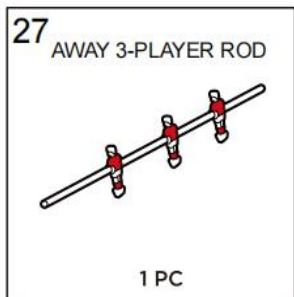
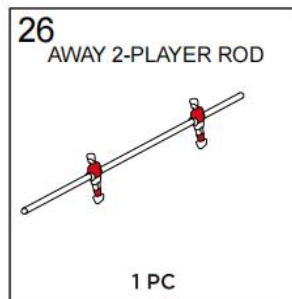
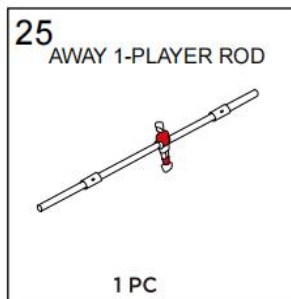
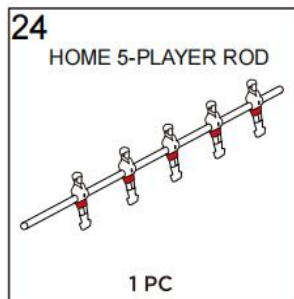
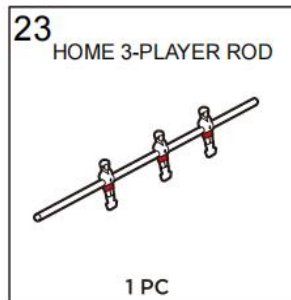
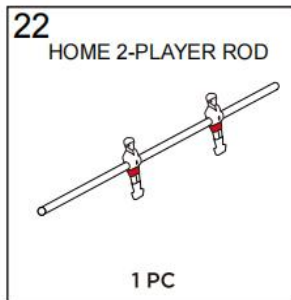
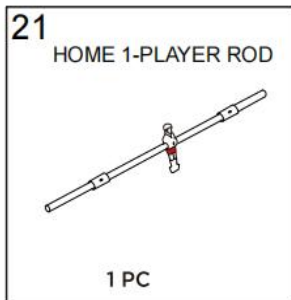

ASSEMBLY INSTRUCTIONS

KROK 1: Umieść panel boczny części 15 z otworem wejściowym piłki bliżej podłogi. Wsuń czteroczęściowe (21-24) pręty gracza domowego z ośmioma częściami 1 gumowe przekładki i osiem części 2 plastio podkładki w wyznaczone otwory.

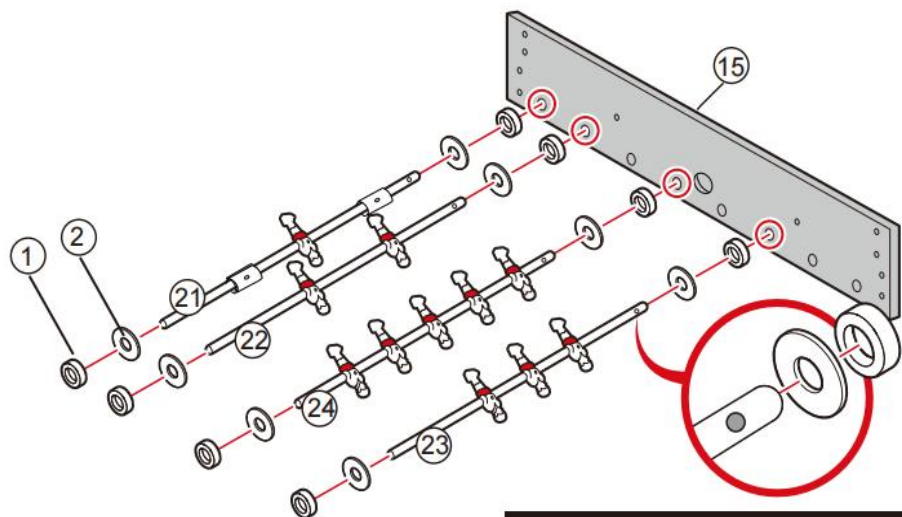

! Make sure that the ends with a hole are arranged on the same side.

KROK 2: Wsuń czteroczęściowe (25-28) wędki z ośmioma częściami 1 gumowe podkładki dystansowe i ośmioczęściowa podkładka z tworzywa sztucznego do wyznaczony dziury.

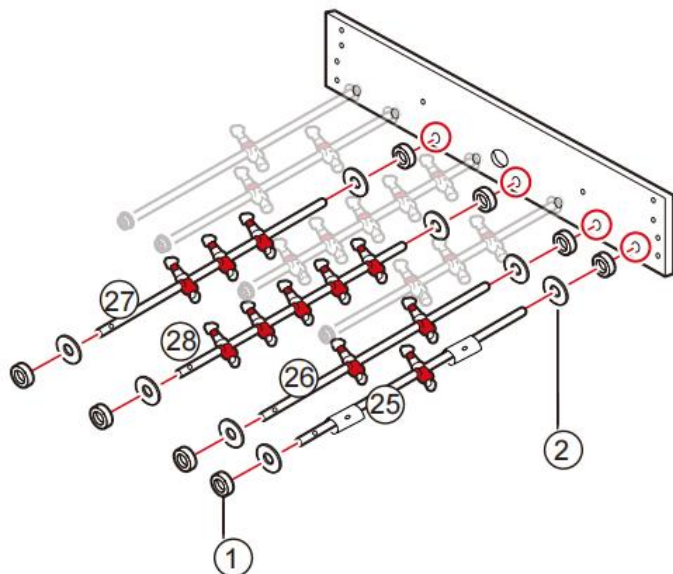

KROK 3: Potwierdź, że pręty są prawidłowo ułożone i gracze na ta sama drużyna zmierzy się z ten sam kierunek.

UWAGA: Liczby i stół jest odwrócony do góry nogami ten schemat .

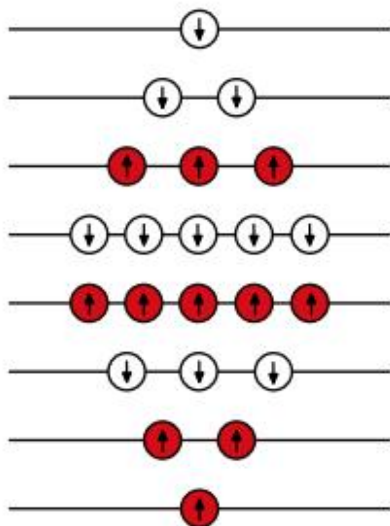

KROK 4: Nasuń drugą część panelu bocznego 15 na pręty.

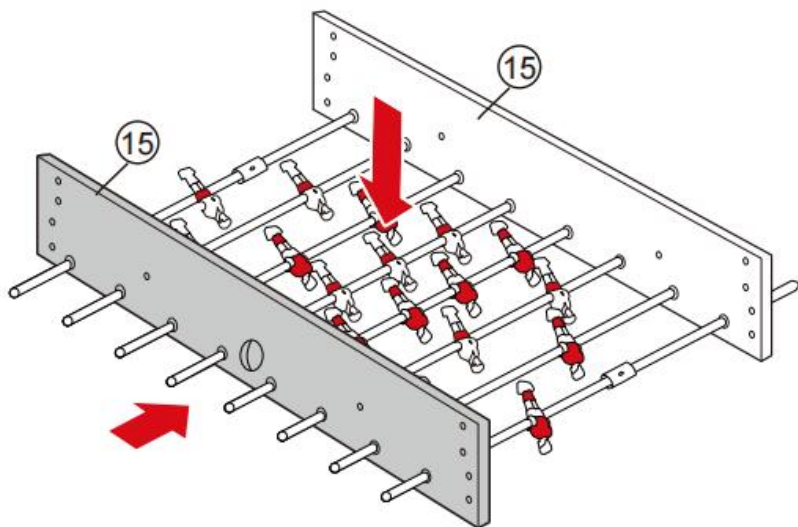

KROK 5: Przymocuj jeden panel końcowy części 18 za pomocą czterech śrub części 6 i czterech podkładek części 5. Odwróć pole gry części 16 do góry nogami i wsuń je w szczeliny paneli bocznych części 15.

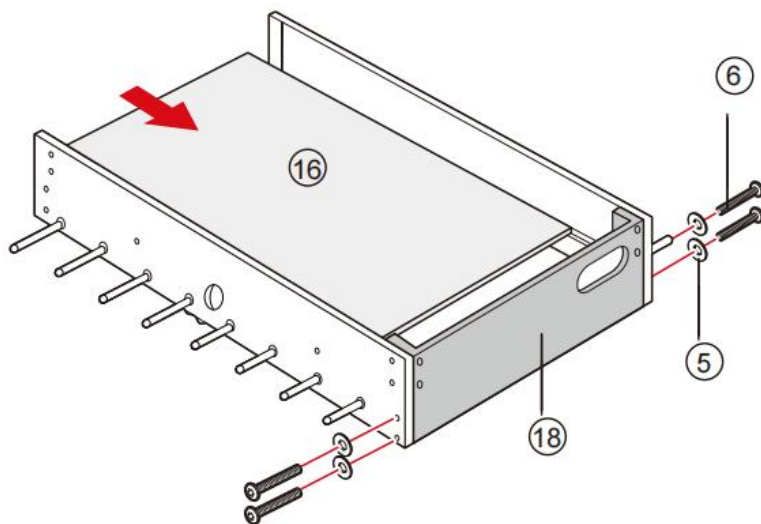

KROK 6: Przymocuj drugi panel końcowy części 18 za pomocą czterech śrub części 6 i czterech podkładek części 5.

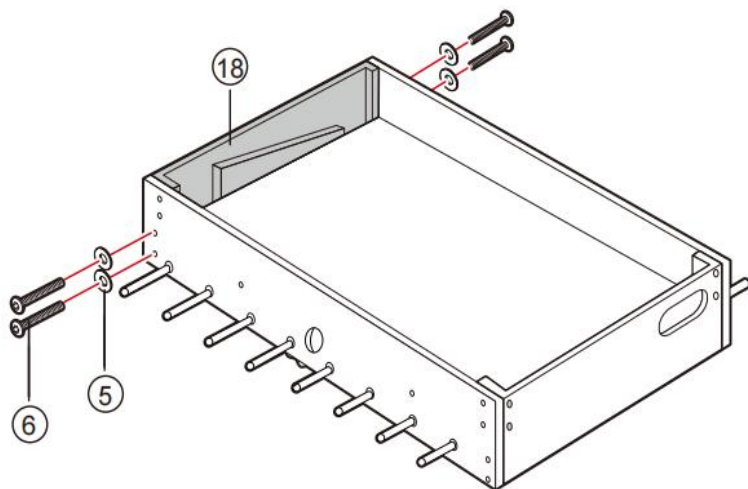

KROK 7: Przymocuj dwa wsporniki części 17 za pomocą czterech śrub części 3 i czterech nakrętek części 4.

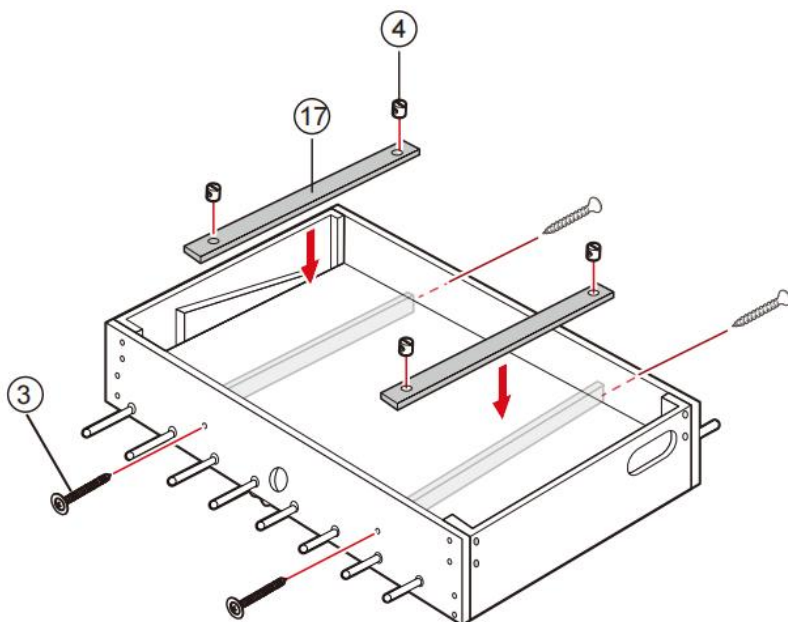

KROK 8: Włóż cztery nogi części 19 w rogi. Umieść dwie części wsporników 20 pomiędzy nogami.

Przymocuj nogi za pomocą szesnastu śrub części 6 i szesnastu podkładek części 5.

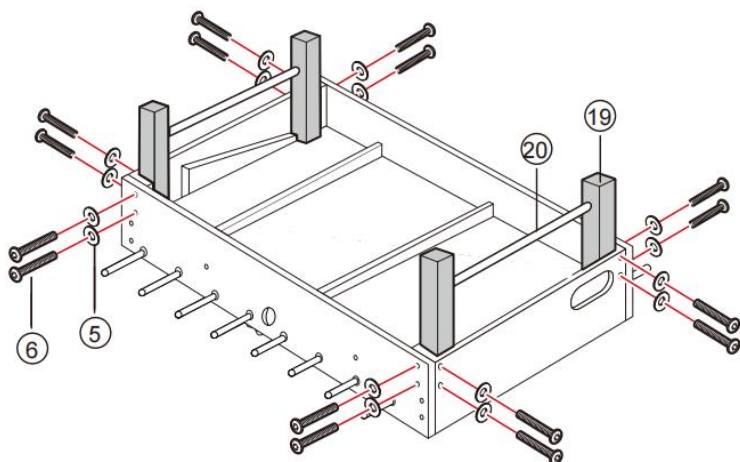

KROK 9: Wkręć cztery części 7 stóp.

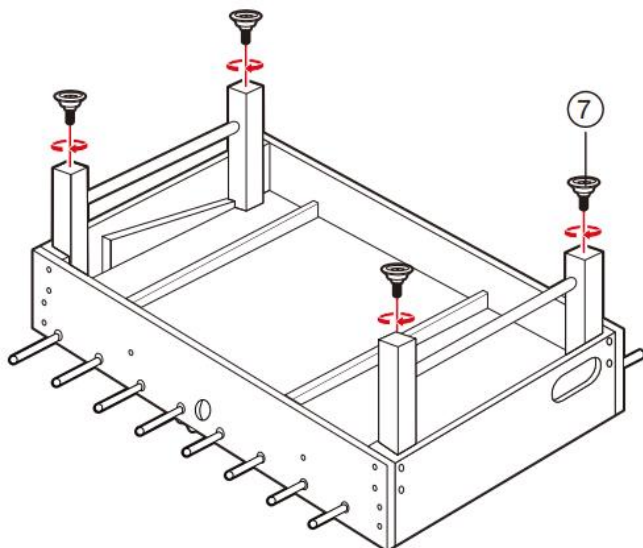

KROK 10: Ostrożnie odwróć stół na drugą stronę.

Przymocuj dwa częściowe uchwyty na kubki 13 za pomocą ośmiu śrub części 9.

UWAGA: Nie podnoś stołu, trzymając się prętów.

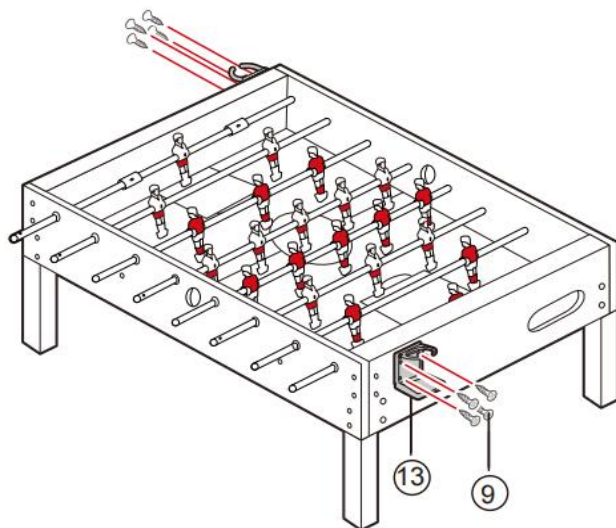

KROK 11: Przymocuj dwie części 14 nacięc czterema śrubami części 8.

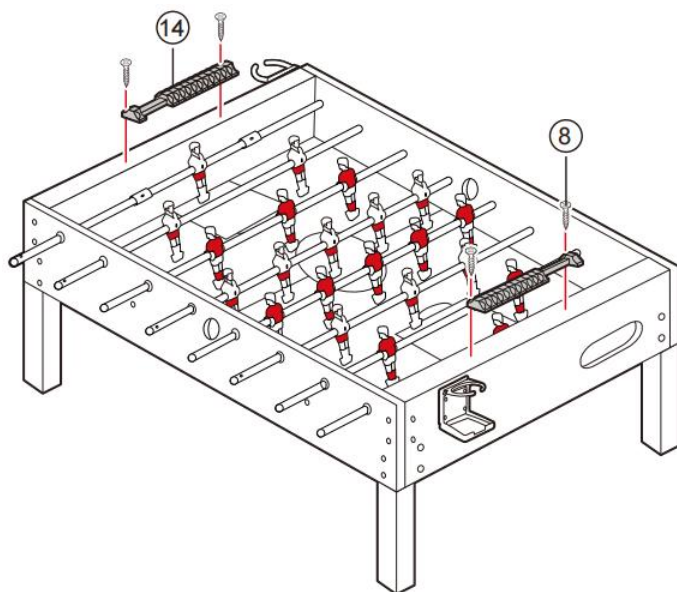

KROK 12: Nasuń osiem uchwytych z części 11 na końce prętów z otworem

Nasuń osiem zaślepek końcowych części 10 na końce prętów bez otworu.

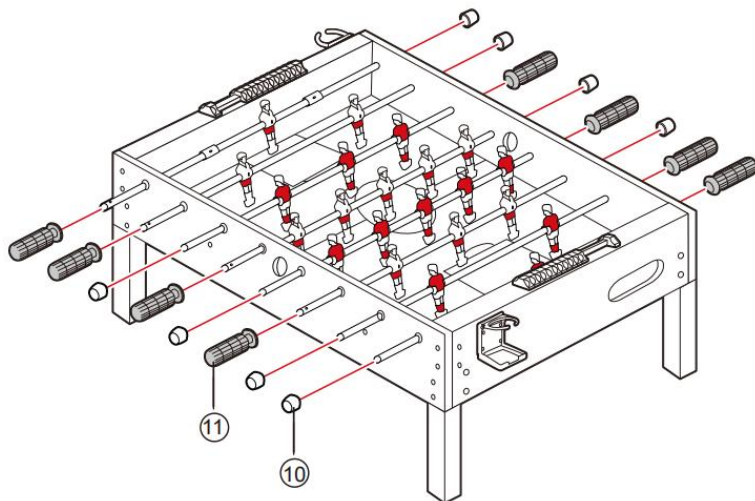

Producent: Shanghai muxin muyeyouxiangongsi

Adres: Baoshanqu Shuangchenglu 803long 11hao 1602A-1609shi
Szanghaj

Import do AUS: SIHAO PTY LTD, 1 ROKEVA STREET EASTWOOD NSW
2122 Australia

Import do USA: Sanven Technology Ltd.
Apartament 250 , 9166 Anaheim Place, Rancho Cucamonga, Kalifornia
91730



SHUNSHUN GmbH
Römeräcker 9 Z2021,76351
Linkenheim-Hochstetten, Germany
euvertreter@gmail.com
+49 1727041930



Pooledas Group Ltd
Unit 5 Albert Edward House, The
Pavilions Preston, United Kingdom
pooledas123@gmail.com
Tel: 01772418127

Wyprodukowano w Chinach

VEVOR[®]

TOUGH TOOLS, HALF PRICE

Techniczny Certyfikat wsparcia i e-gwarancji

www.vevor.com/support

VEVOR[®]

TOUGH TOOLS, HALF PRICE

Technisch Ondersteuning en e-garantiecertificaat

www.vevor.com/support

TAFELVOETBAL

MODEL : SUO-4824GW

We continue to be committed to provide you tools with competitive price.

"Save Half", "Half Price" or any other similar expressions used by us only represents an estimate of savings you might benefit from buying certain tools with us compared to the major top brands and does not necessarily mean to cover all categories of tools offered by us. You are kindly reminded to verify carefully when you are placing an order with us if you are actually saving half in comparison with the top major brands.

VEVOR[®]

TOUGH TOOLS, HALF PRICE

TABLE SOCCER

MODEL: SUO-4824GW

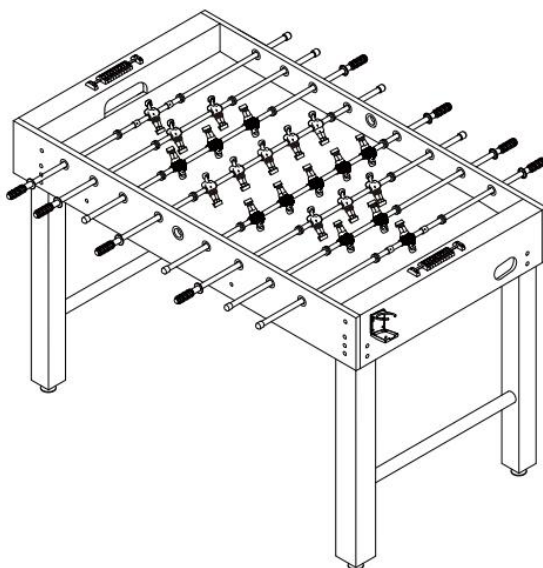

NEED HELP? CONTACT US!

Have product questions? Need technical support? Please feel free to contact us:

Technical Support and E-Warranty Certificate
www.vevor.com/support

This is the original instruction, please read all manual instructions carefully before operating. VEVOR reserves a clear interpretation of our user manual. The appearance of the product shall be subject to the product you received. Please forgive us that we won't inform you again if there are any technology or software updates on our product.



Waarschuwing-Om het risico op letsel te verminderen, moet de gebruiker de handleiding zorgvuldig lezen.

SAFETY WARNINGS AND PRECAUTIONS

Bedankt voor het gebruik van dit product . Om er zeker van te zijn dat u de machine correct kunt bedienen, dient u deze instructie zorgvuldig door te lezen voordat u de machine gebruikt en deze goed te bewaren voor toekomstig gebruik . Zorg ervoor dat u de voorzorgsmaatregelen en veiligheidsregels op deze pagina leest om een veilig gebruik te garanderen . Deze handleiding beschrijft veiligheidswaarschuwingen en voorzorgsmaatregelen, bediening en onderhoud . De waarschuwingen en instructies die in deze handleiding worden besproken, kunnen niet alle mogelijke omstandigheden en situaties dekken die zich kunnen voordoen . Voorzichtigheid en gezond verstand zijn niet ingebouwd in dit product, omdat wij van mening zijn dat het gebruik aan deze codes zal voldoen .

Lees ALLE instructies voordat u uw machine gebruikt .

1. Bij het monteren moeten deze instructies worden gevolgd. Een onjuiste montage kan een gevaar vormen.
2. Niet monteren als u moe bent of onder invloed bent van alcohol, drugs of medicijnen.
3. Gewichts- en elastische en andere producteigenschappen zijn alleen van toepassing op correct en compleet gemonteerde producten.
4. Houd de verzamelplaats schoon en goed verlicht.
5. Houd omstanders tijdens de montage uit de buurt.
6. Dit is een apparaat, geen speelgoed, het moet worden gebruikt onder begeleiding van een professional. Laat kinderen en huisdieren niet alleen spelen of in de buurt van dit artikel komen.
7. Alleen gebruiken zoals bedoeld. Ga niet op het product zitten of staan.
8. Inspecteer vóór elk gebruik. Gebruik het niet als onderdelen loszitten of beschadigd zijn.
- 9 . Gebruik dit apparaat niet voor andere doeleinden dan het aangegeven gebruik .



















- 1 0 . Gebruik het niet voor commerciële doeleinden .
 - 1 1 . Maak het niet schoon met schurend materiaal .
 - 1 2 . Laat het nooit onbeheerd achter terwijl het in gebruik is .
 - 1 3 . Urine en uitwerpselen van huisdieren kunnen het product beschadigen, blijf uit de buurt .
 - 1 4 . Plaats het product niet op of in de buurt van hete lucht, elektrische branders of verwarmingstoestellen .
 - 15 . Op jonge kinderen moet toezicht worden gehouden om ervoor te zorgen dat ze niet met het product spelen . Huisdieren moeten uit de buurt van het product blijven.
- Niet buitenshuis gebruiken op regenachtige en bewolkte dagen, vermijd blikseminslagen en vallen . Mensen of huisdieren die aan het product hangen, kunnen letsel of de dood veroorzaken .

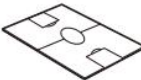

WAARSCHUWING: Verstikkingsgevaar – Speelgoed bevat kleine balletjes en/of kleine onderdelen. Niet voor kinderen jonger dan 3 jaar.

BELANGRIJK! Lees eerst dit instructieboek door voordat u met de montage begint, zodat u vertrouwd raakt met alle onderdelen en montagestappen. Wij raden aan dat twee volwassenen dit spel in elkaar zetten. Raadpleeg de onderstaande onderdelenlijst en zorg ervoor dat alle onderdelen aanwezig zijn.

PARTS LIST

<p>1 RUBBER SPACER</p>  <p>16 PCS</p>	<p>2 PLASTIC WASHER</p>  <p>16 PCS</p>	<p>3 RWA 3.5X35MM</p>  <p>4 PCS</p>	<p>4 BARREL NUT</p>  <p>4 PCS</p>	<p>5 WASHER</p>  <p>24 PCS</p>
<p>6 TM 6X40MM BOLT</p>  <p>24 PCS</p>	<p>7 FEET</p>  <p>4 PCS</p>	<p>8 FA 3.5X28MM</p>  <p>4 PCS</p>	<p>9 FA 3.5X12MM</p>  <p>8 PCS</p>	<p>10 END CAP</p>  <p>8 PCS</p>
<p>11 HANDLE</p>  <p>8 PCS</p>	<p>12 SOCCER BALL</p>  <p>2 PCS</p>	<p>13 CUP HOLDER</p>  <p>2 PCS</p>	<p>14 SCORER</p>  <p>2 PCS</p>	<p>15 SIDE PANEL</p>  <p>2 PCS</p>
<p>16 PLAYFIELD</p>  <p>1 PC</p>	<p>17 SUPPORT</p>  <p>2 PCS</p>	<p>18 END PANEL</p>  <p>2 PCS</p>	<p>19 LEG</p>  <p>4 PCS</p>	<p>20 LEG SUPPORT</p>  <p>2 PCS</p>

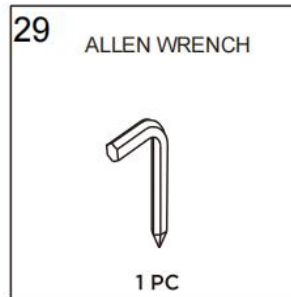
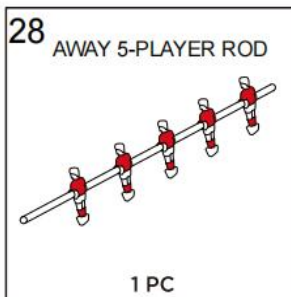
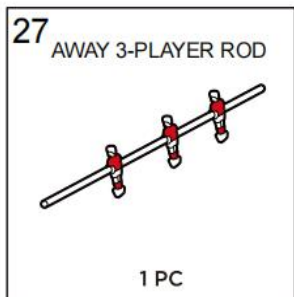
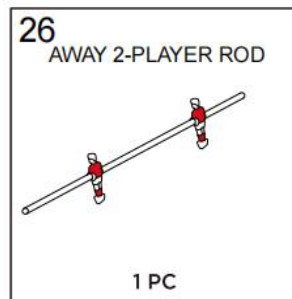
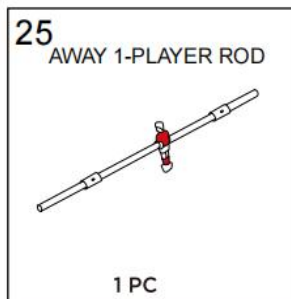
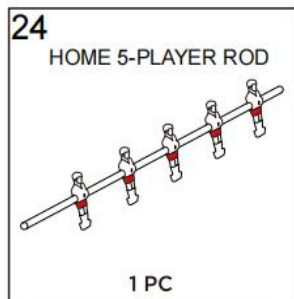
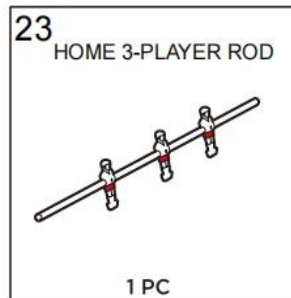
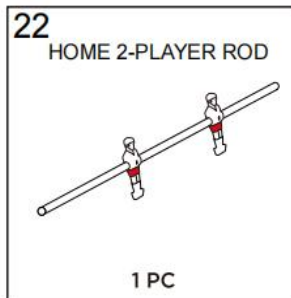
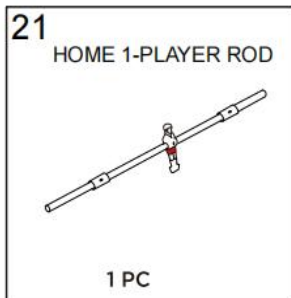

ASSEMBLY INSTRUCTIONS

STAP1: Plaats een zijpaneel met onderdeel 15, met het balinvoergat dichterbij de vloer. Schuif vierdelige (21-24) thuisspelerstangen met acht onderdelen 1 rubberen afstandhouders en acht deel 2 plastic sluitringen in de daarvoor bestemde gaten.

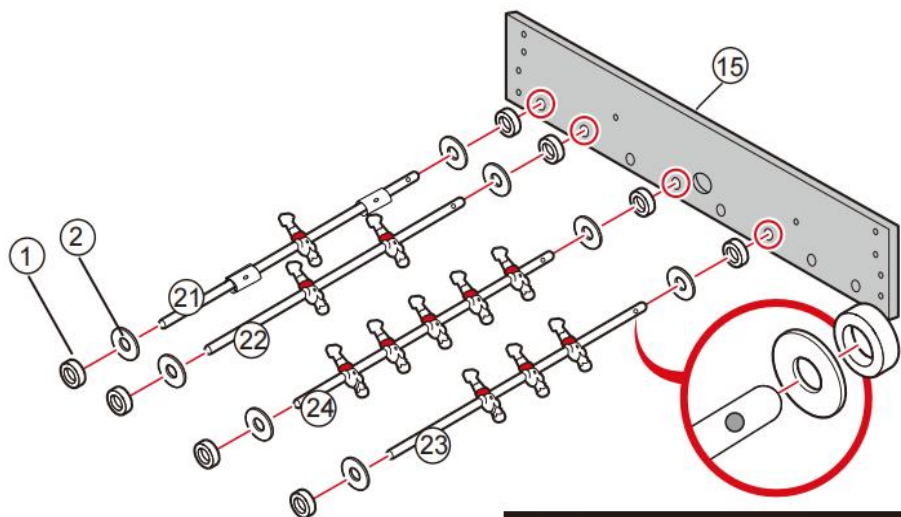

! Make sure that the ends with a hole are arranged on the same side.

STAP2: Schuif vierdelige (25-28) wegspeleerhengels met achtdelige 1 rubberen afstandhouders en acht deel 2 plastic sluitringen naar de toegewezen gaten.

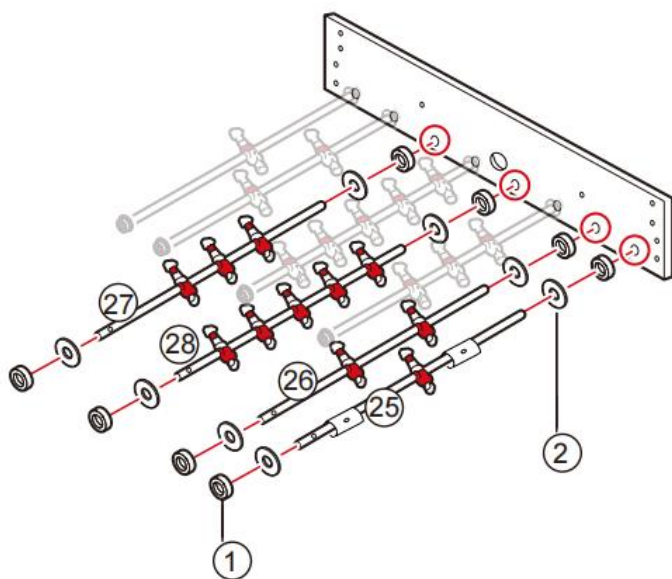

STAP3: Bevestig dat de staven zijn correct geregeld en de spelers op de hetzelfde team staat tegenover de dezelfde richting.

OPMERKING: De figuren en tafel staat ondersteboven in dit diagram .

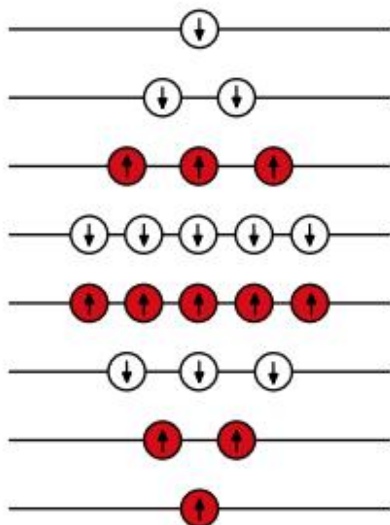

STAP4: Schuif het andere deel 15 zijpaneel op de stangen.

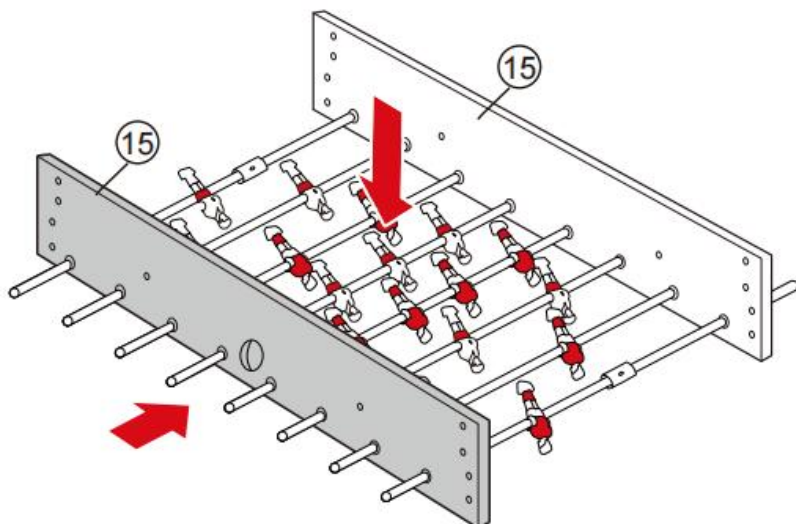

STAP 5: Bevestig één eindpaneel uit deel 18 met vier bouten uit deel 6 en vier ringen uit deel 5. Draai het speelveld van deel 16 ondersteboven en schuif het in de sleuven van de zijpanelen van deel 15.

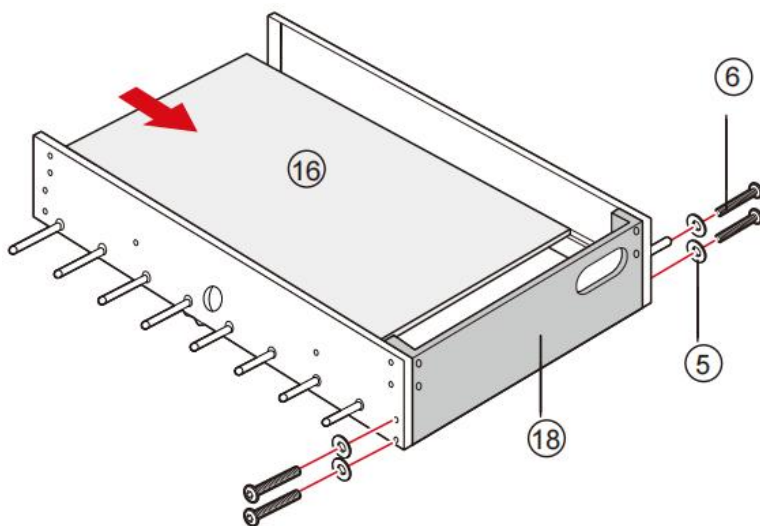

STAP6: Bevestig het andere eindpaneel van deel 18 met vier bouten van deel 6 en vier ringen van deel 5.

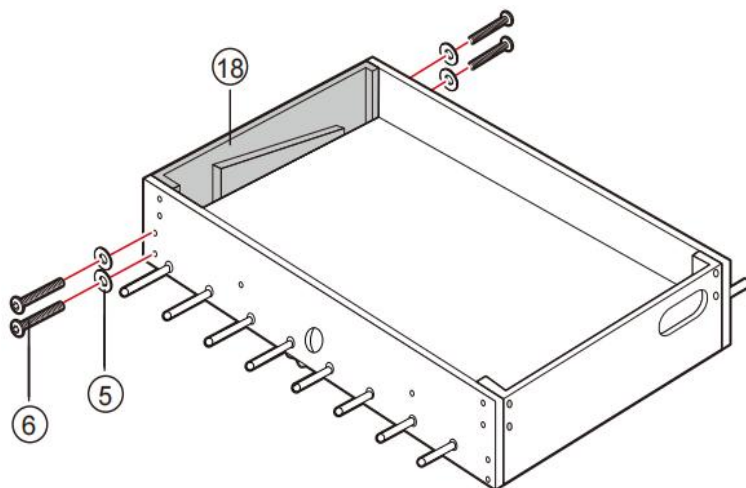

STAP7: Bevestig twee steunen uit deel 17 met vier schroeven uit deel 3 en vier moeren uit deel 4.

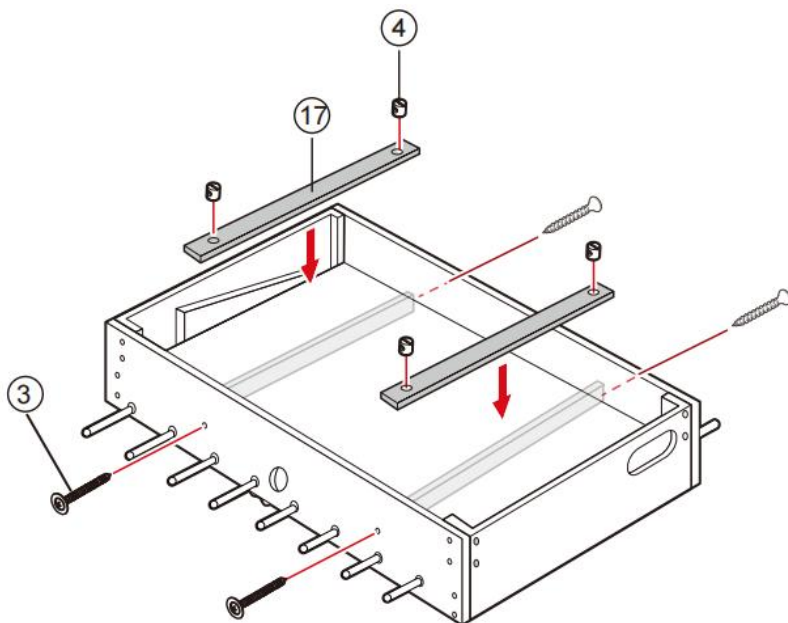

STAP8: Steek vier deel 19 poten in de hoeken.
Plaats twee deel 20 steunbalken tussen de benen.
Bevestig de poten met zestien deel 6 bouten en zestien deel 5 ringen.

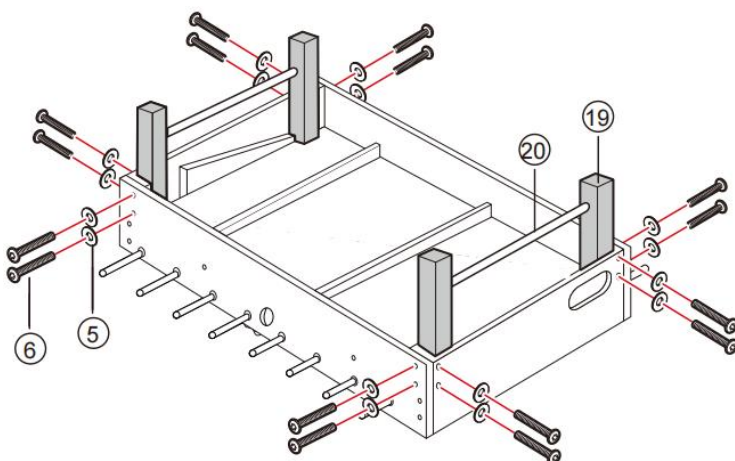

STAP9: Schroef vier delen van 7 voet vast.

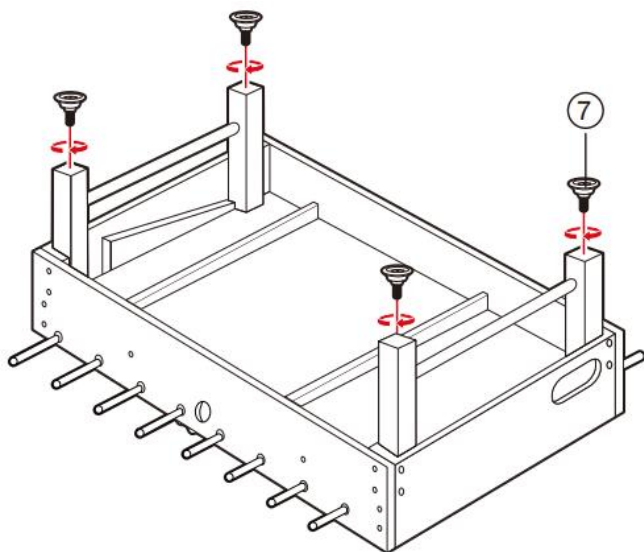

STAP10: Draai de tafel voorzichtig om.

Bevestig twee deel 13 bekerhouders met acht deel 9 schroeven.

OPMERKING: Til de tafel niet op terwijl u de stangen vasthoudt.

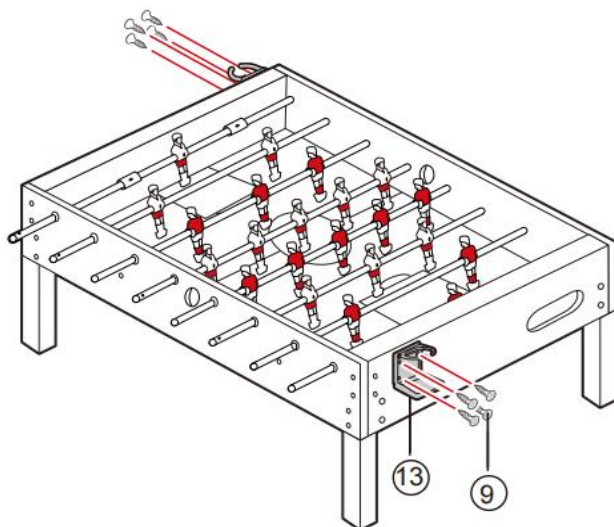

STAP11: Bevestig twee deel 14scorers met vier deel 8 schroeven.

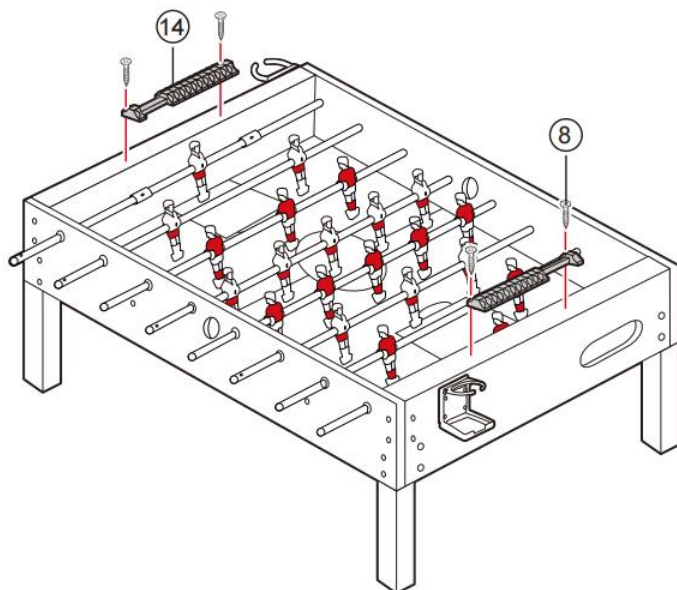

STAP12: Schuif acht deel 11 handgrepen op de uiteinden van stangen met een gat

Schuif acht deel 10 eindkappen op de uiteinden van stangen zonder gat.

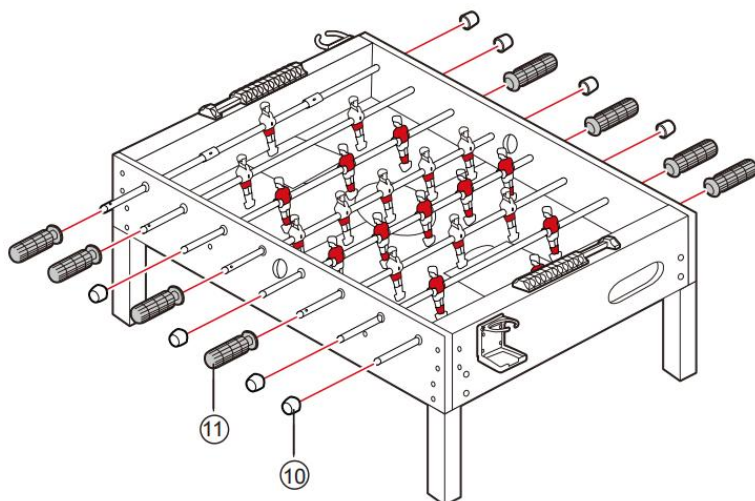

Fabrikant: Shanghai muxinmuyeyouxiangongsi

Adres: Baoshanqu Shuangchenglu 803long 11hao 1602A-1609shi
Shanghai

Geïmporteerd naar AUS: SIHAO PTY LTD, 1 ROKEVA
STREETEASTWOOD NSW 2122 Australië

Geïmporteerd naar de VS: Sanven Technology Ltd.
Suite 250 , 9166 Anaheim Place, Rancho Cucamonga, CA 91730



SHUNSHUN GmbH
Römeräcker 9 Z2021,76351
Linkenheim-Hochstetten, Germany
euvertreter@gmail.com
+49 1727041930



Pooledas Group Ltd
Unit 5 Albert Edward House, The
Pavilions Preston, United Kingdom
pooledas123@gmail.com
Tel: 01772418127

Gemaakt in China

VEVOR[®]

TOUGH TOOLS, HALF PRICE

Technisch Ondersteuning en e-garantiecertificaat

www.vevor.com/support

VEVOR[®]

TOUGH TOOLS, HALF PRICE

Teknisk Support och e-garanticertifikat

www.vevor.com/support

BORDSFOTBOLL

MODELL : SUO-4824GW

We continue to be committed to provide you tools with competitive price.

"Save Half", "Half Price" or any other similar expressions used by us only represents an estimate of savings you might benefit from buying certain tools with us compared to the major top brands and does not necessarily mean to cover all categories of tools offered by us. You are kindly reminded to verify carefully when you are placing an order with us if you are actually saving half in comparison with the top major brands.

VEVOR®

TOUGH TOOLS, HALF PRICE

TABLE SOCCER

MODELL: SUO-4824GW

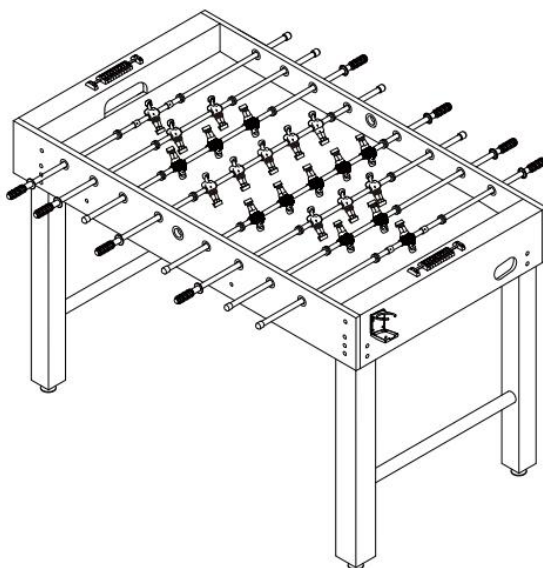

NEED HELP? CONTACT US!

Have product questions? Need technical support? Please feel free to contact us:

Technical Support and E-Warranty Certificate
www.vevor.com/support

This is the original instruction, please read all manual instructions carefully before operating. VEVOR reserves a clear interpretation of our user manual. The appearance of the product shall be subject to the product you received. Please forgive us that we won't inform you again if there are any technology or software updates on our product.



Varning - För att minska risken för skada måste användaren läsa instruktionerna noggrant.

SAFETY WARNINGS AND PRECAUTIONS

Tack för att du använder den här produkten . För att försäkra dig om att du kan använda maskinen korrekt, läs denna instruktion noggrant före användning och förvara den på rätt sätt för framtida referens . Var noga med att läsa försiktighetsåtgärderna och säkerhetsreglerna på den här sidan för att säkerställa din säker användning . Denna handbok kommer att beskriva säkerhetsvarningar och försiktighetsåtgärder, drift, underhåll . Varningarna och instruktionerna som granskas i denna handbok kan inte täcka alla möjliga tillstånd och situationer som kan uppstå . Försiktighet och sunt förnuft är inte inbyggt i denna produkt, eftersom vi tror att användningen kommer att följa dessa koder .

Läs ALLA instruktionerna innan du använder din maskin .

1. Montering måste följa dessa instruktioner. Felaktig montering kan vara en fara.
2. Sätt dig inte ihop när du är trött eller påverkad av alkohol, droger eller mediciner.
3. Vikt och elastik och andra produkttegenskaper är endast tillämpliga på korrekt och fullständigt monterade produkter.
4. Håll monteringsområdet rent och väl upplyst.
5. Håll åskådare borta från området under monteringen.
6. Detta är en utrustning, inte en leksak, den måste användas under ledning av en professionell. Tillåt inte barn och husdjur att leka ensamma eller närma sig detta föremål.
7. Använd endast på avsett sätt. Sitt eller stå inte på produkten.
8. Inspektera före varje användning. Använd den inte om delar är lösa eller skadade.
- 9 . Använd inte denna enhet för andra ändamål än den angivna användningen .
- 10 . Använd den inte för kommersiella ändamål .



















- 1 1 . Rengör den inte med något slipande material .
 - 1 2 . Lämna den aldrig utan uppsikt när den används .
 - 1 3 . Urin och avföring från husdjur kan skada produkten, håll undan .
 - 1 4 . Placera inte produkten på eller nära varmluft, elektriska brännare eller värmare .
 - 15 . Små barn bör övervakas för att säkerställa att de inte leker med produkten . Husdjur bör hålla sig borta från produkten.
- Använd inte utomhus under regniga och molniga dagar, undvik blixtnedslag och fall . Människor eller husdjur som hänger på produkten kommer att orsaka skada eller dödsfall .

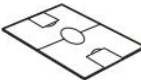

WARNING: Kvävningsrisk - Leksaken innehåller små bollar och/eller små delar. Ej för barn under 3 år.

VIKTIG! Innan du försöker montera, läs igenom denna instruktionsbok för att bekanta dig med alla delar och monteringssteg. Vi rekommenderar att två vuxna monterar detta spel. Se reservdelslistan nedan och se till att alla delar har medföljt.

PARTS LIST

<p>1 RUBBER SPACER</p>  <p>16 PCS</p>	<p>2 PLASTIC WASHER</p>  <p>16 PCS</p>	<p>3 RWA 3.5X35MM</p>  <p>4 PCS</p>	<p>4 BARREL NUT</p>  <p>4 PCS</p>	<p>5 WASHER</p>  <p>24 PCS</p>
<p>6 TM 6X40MM BOLT</p>  <p>24 PCS</p>	<p>7 FEET</p>  <p>4 PCS</p>	<p>8 FA 3.5X28MM</p>  <p>4 PCS</p>	<p>9 FA 3.5X12MM</p>  <p>8 PCS</p>	<p>10 END CAP</p>  <p>8 PCS</p>
<p>11 HANDLE</p>  <p>8 PCS</p>	<p>12 SOCCER BALL</p>  <p>2 PCS</p>	<p>13 CUP HOLDER</p>  <p>2 PCS</p>	<p>14 SCORER</p>  <p>2 PCS</p>	<p>15 SIDE PANEL</p>  <p>2 PCS</p>
<p>16 PLAYFIELD</p>  <p>1 PC</p>	<p>17 SUPPORT</p>  <p>2 PCS</p>	<p>18 END PANEL</p>  <p>2 PCS</p>	<p>19 LEG</p>  <p>4 PCS</p>	<p>20 LEG SUPPORT</p>  <p>2 PCS</p>

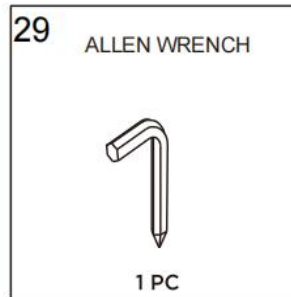
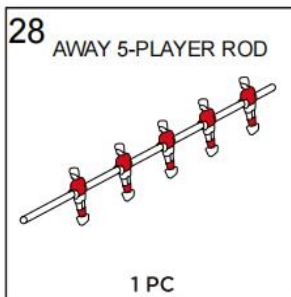
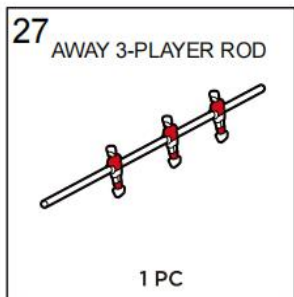
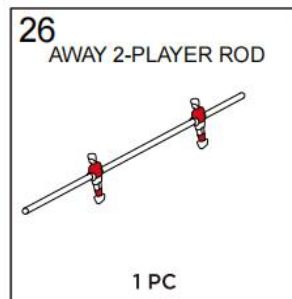
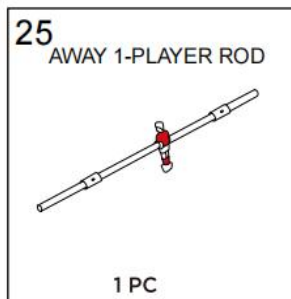
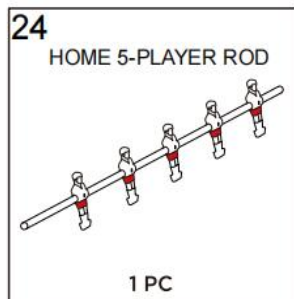
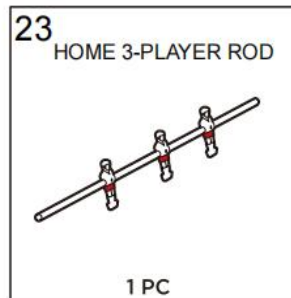
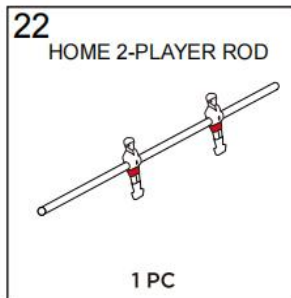
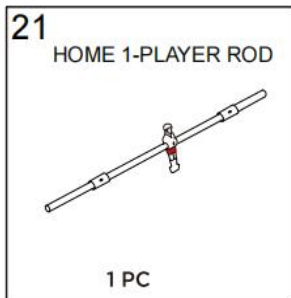

ASSEMBLY INSTRUCTIONS

STEG 1: Placera en del 15-sidopanel med kulinloppshålet närmare golvet. Skjut fyradelade (21-24) hemmaspelarstavar med en del 1 gummidistanser och åtta del 2 plastio brickor i de avsedda hålen.

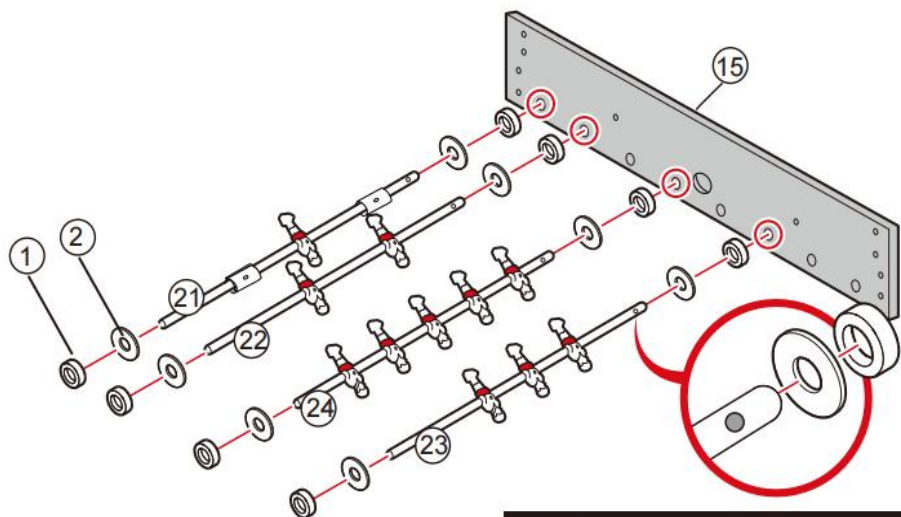

! Make sure that the ends with a hole are arranged on the same side.

STEG 2: Skjut bort fyra delar (25-28) spelarstavar med åtta delar 1 gummistav och åtta del 2 plastbrickor till utsedda hål.

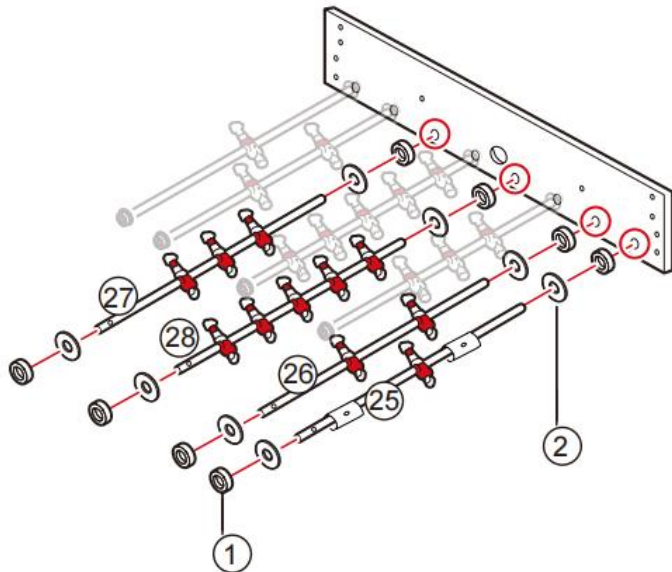

STEG 3: Bekräfta att stavarna är rätt ordnade och spelarna på samma lag möter samma riktning.

OBS: Siffrorna och bordet är upp och ner i detta diagram .

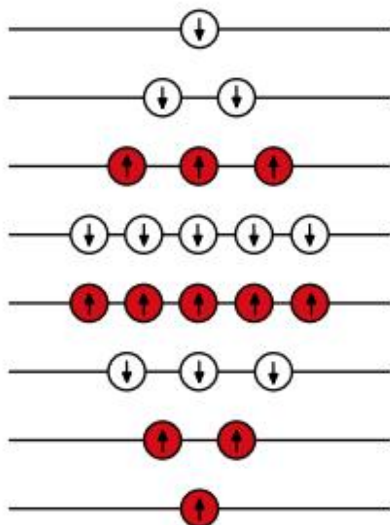

STEG4: Skjut den andra delen 15 sidopanelen på stängerna.

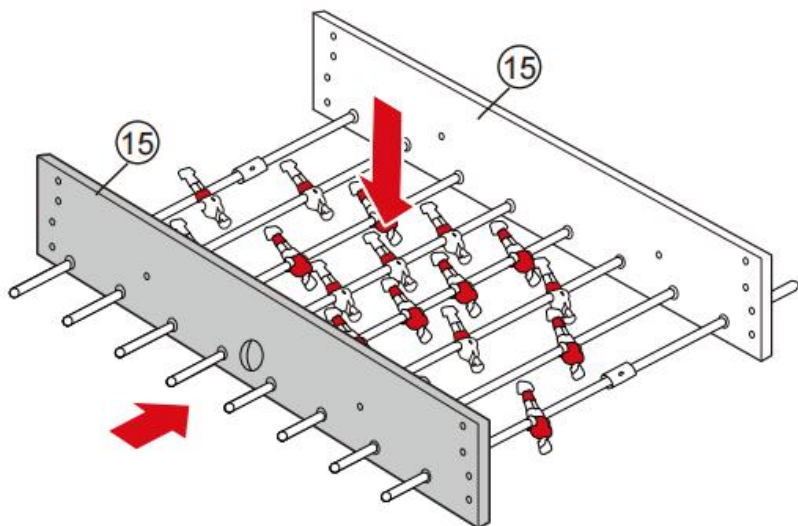

STEG 5: Fäst en del 18-ändpanel med fyra del 6-bultar och fyra del 5-brickor. Vänd del 16-spelfältet upp och ner och skjut in det i skårorna på del 15-sidopanelerna.

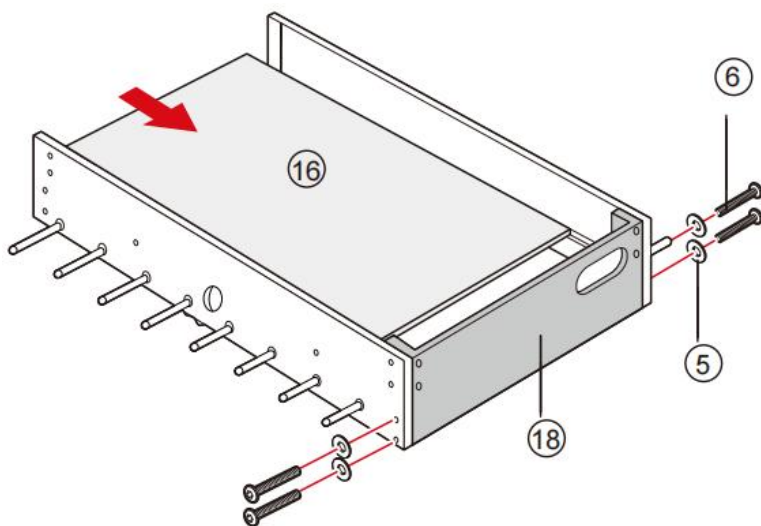

STEG6: Fäst den andra delen 18 ändpanelen med fyra del 6 bultar och fyra del 5 brickor.

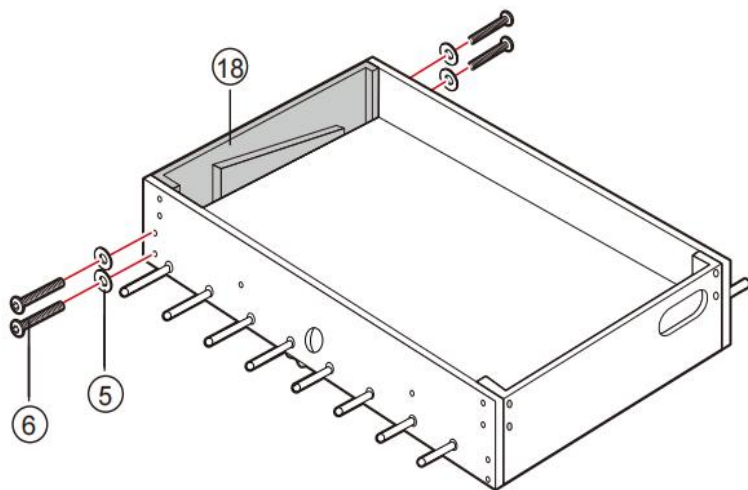

STEG7: Fäst två del 17 stöd med fyra del 3 skruvar och fyra del 4 muttrar.

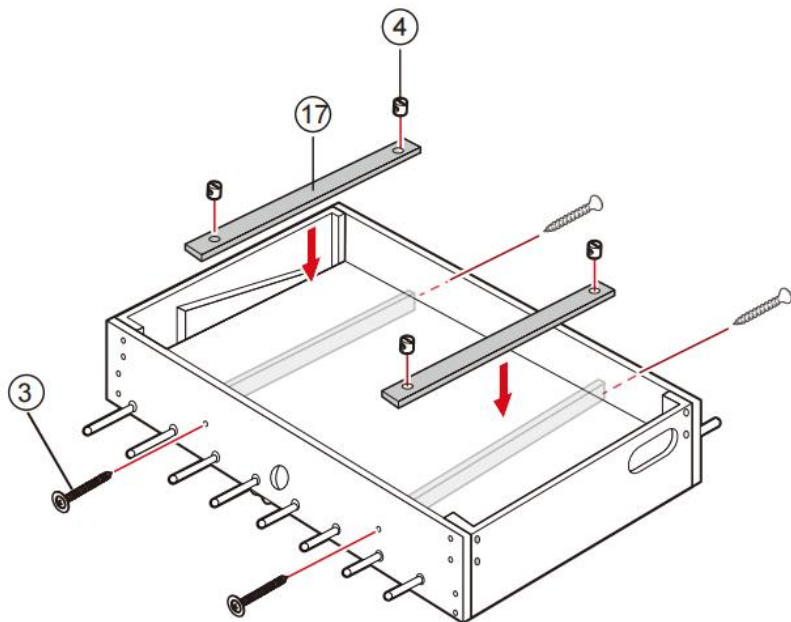

STEG 8: Sätt in fyra del 19-ben i hörnen.

Placera två del 20 stödsträngar mellan benen.

Fäst benen med sexton del 6 bultar och sexton del 5 brickor.

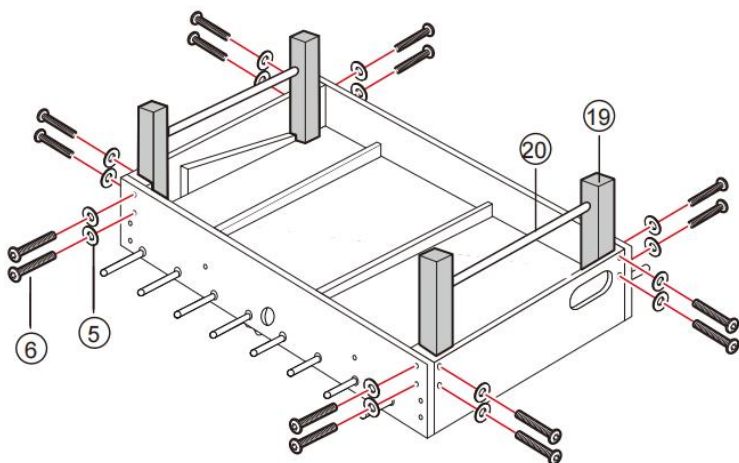

STEG9: Skruva i fyra delar 7 fot.

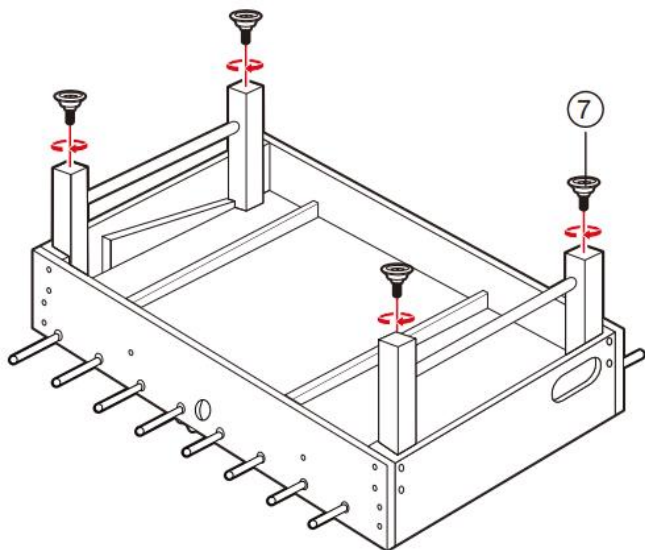

STEG 10: Vänd försiktigt på bordet.

Fäst två del 13 mugghållare med åtta del 9 skruvar.

OBS: Lyft inte bordet medan du håller i stängerna.

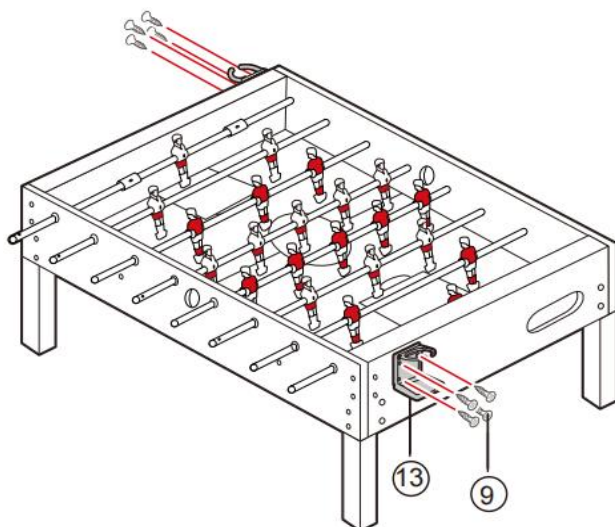

STEG11: Fäst två del 14 målskyttar med fyra del 8 skruvar.

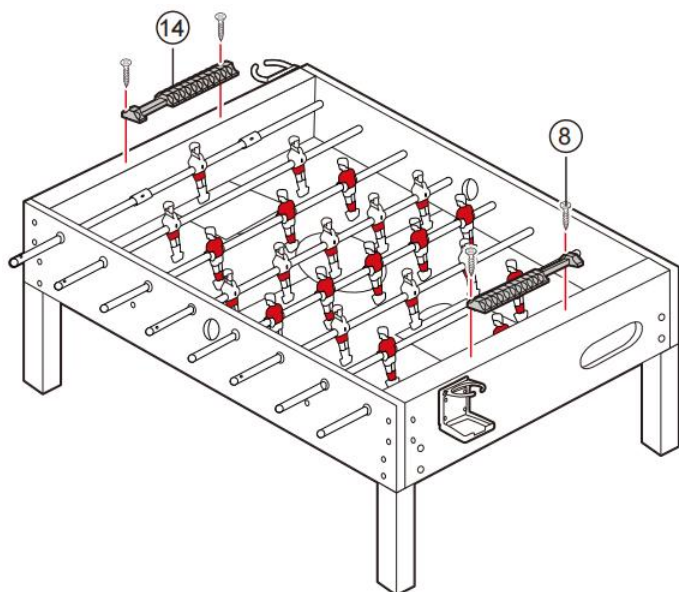

STEG 12: Skjut åtta del 11 handtag på ändarna av stavar med ett hål
Skjut åtta del 10 ändlock på ändarna av stavar utan hål.

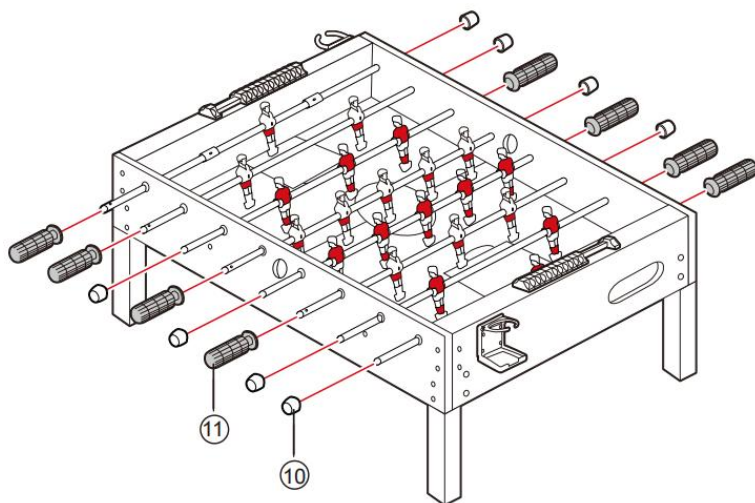

Tillverkare: Shanghaimuxinmuyeyouxiangongsi

Adress: Baoshanqu Shuangchenglu 803long 11hao 1602A-1609shi
Shanghai

Importerad till AUS: SIHAO PTY LTD, 1 ROKEVA STREETEASTWOOD
NSW 2122 Australien

Importerad till USA: Sanven Technology Ltd.
Suite 250 , 9166 Anaheim Place, Rancho Cucamonga, CA 91730



SHUNSHUN GmbH
Römeräcker 9 Z2021,76351
Linkenheim-Hochstetten,Germany
euvertreter@gmail.com
+49 1727041930



Pooledas Group Ltd
Unit 5 Albert Edward House, The
Pavilions Preston, United Kingdom
pooledas123@gmail.com
Tel: 01772418127

Tillverkad i Kina

VEVOR[®]

TOUGH TOOLS, HALF PRICE

Teknisk Support och e-garanticertifikat

www.vevor.com/support

VEVOR[®]

TOUGH TOOLS, HALF PRICE

Técnico Certificado de soporte y garantía electrónica

www.vevor.com/support

FUTBOLÍN

MODELO : SUO-4824GW

We continue to be committed to provide you tools with competitive price.

"Save Half", "Half Price" or any other similar expressions used by us only represents an estimate of savings you might benefit from buying certain tools with us compared to the major top brands and does not necessarily mean to cover all categories of tools offered by us. You are kindly reminded to verify carefully when you are placing an order with us if you are actually saving half in comparison with the top major brands.

VEVOR[®]

TOUGH TOOLS, HALF PRICE

TABLE SOCCER

MODELO: SUO-4824GW

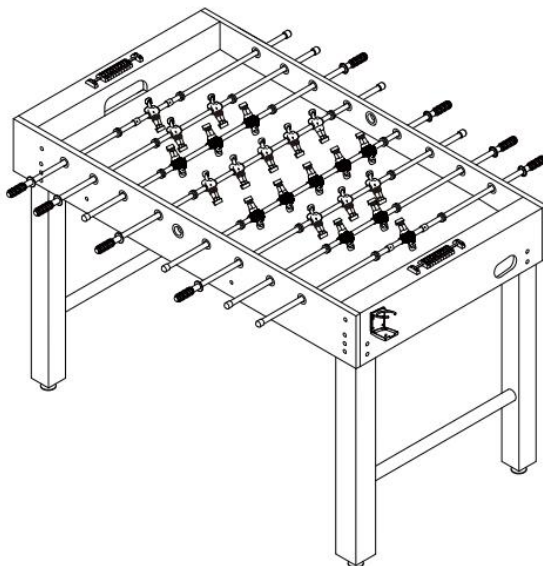

NEED HELP? CONTACT US!

Have product questions? Need technical support? Please feel free to contact us:

Technical Support and E-Warranty Certificate
www.vevor.com/support

This is the original instruction, please read all manual instructions carefully before operating. VEVOR reserves a clear interpretation of our user manual. The appearance of the product shall be subject to the product you received. Please forgive us that we won't inform you again if there are any technology or software updates on our product.



Advertencia: para reducir el riesgo de lesiones, el usuario debe leer atentamente el manual de instrucciones.

SAFETY WARNINGS AND PRECAUTIONS

Gracias por usar este producto . Para asegurarse de que puede operar la máquina correctamente, lea atentamente estas instrucciones antes de utilizarla y consérvelas adecuadamente para consultarlas en el futuro . Asegúrese de leer las precauciones y reglas de seguridad en esta página para garantizar su uso seguro . Este manual describirá las advertencias y precauciones de seguridad, operación y mantenimiento . Las advertencias e instrucciones revisadas en este manual no pueden cubrir todas las condiciones y situaciones posibles que puedan ocurrir . Este producto no incluye precaución ni sentido común, ya que creemos que los usos cumplirán con estos códigos .

Lea TODAS las instrucciones antes de utilizar su máquina .

1. El montaje debe seguir estas instrucciones. El montaje incorrecto puede ser un peligro.
2. No reunirse cuando esté cansado o bajo la influencia de alcohol, drogas o medicamentos.
3. El peso, la elasticidad y otras propiedades del producto solo se aplican a productos ensamblados correcta y completamente.
4. Mantenga el área de montaje limpia y bien iluminada.
5. Mantenga a las personas transeúntes fuera del área durante el montaje.
6. Este es un equipo, no un juguete, debe usarse bajo la guía de un profesional. No permita que los niños y las mascotas jueguen solos o se acerquen a este artículo.
7. Úselo únicamente según lo previsto. No se sienta ni se pare sobre el producto.
8. Inspeccione antes de cada uso. No lo utilice si las piezas están sueltas o dañadas.
- 9 . No utilice esta unidad para ningún otro propósito que no sea el indicado .



















- 1 0 . No lo utilice con fines comerciales .
 - 1 1 . No lo limpie con ningún material abrasivo .
 - 1 2 . Nunca lo deje desatendido mientras esté en uso .
 - 1 3 . La orina y las heces de las mascotas pueden dañar el producto; manténgalo alejado .
 - 1 4 . No coloque el producto sobre o cerca de aire caliente, quemadores o calentadores eléctricos .
 - 15 . Se debe supervisar a los niños pequeños para asegurarse de que no jueguen con el producto . Las mascotas deben mantenerse alejadas del producto.
- No utilizar al aire libre en días lluviosos y nublados, evitar rayos y caídas . Las personas o mascotas que cuelguen del producto causarán lesiones o la muerte .

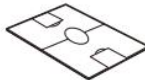

ADVERTENCIA: Peligro de asfixia: el juguete contiene pelotas pequeñas y/o piezas pequeñas. No apto para niños menores de 3 años.

¡IMPORTANTE! Antes de intentar el montaje, lea este libro de instrucciones para familiarizarse con todas las piezas y los pasos de montaje. Recomendamos que dos adultos monten este juego. Consulte la lista de piezas a continuación y asegúrese de que se hayan incluido todas las piezas.

PARTS LIST

<p>1 RUBBER SPACER</p>  <p>16 PCS</p>	<p>2 PLASTIC WASHER</p>  <p>16 PCS</p>	<p>3 RWA 3.5X35MM</p>  <p>4 PCS</p>	<p>4 BARREL NUT</p>  <p>4 PCS</p>	<p>5 WASHER</p>  <p>24 PCS</p>
<p>6 TM 6X40MM BOLT</p>  <p>24 PCS</p>	<p>7 FEET</p>  <p>4 PCS</p>	<p>8 FA 3.5X28MM</p>  <p>4 PCS</p>	<p>9 FA 3.5X12MM</p>  <p>8 PCS</p>	<p>10 END CAP</p>  <p>8 PCS</p>
<p>11 HANDLE</p>  <p>8 PCS</p>	<p>12 SOCCER BALL</p>  <p>2 PCS</p>	<p>13 CUP HOLDER</p>  <p>2 PCS</p>	<p>14 SCORER</p>  <p>2 PCS</p>	<p>15 SIDE PANEL</p>  <p>2 PCS</p>
<p>16 PLAYFIELD</p>  <p>1 PC</p>	<p>17 SUPPORT</p>  <p>2 PCS</p>	<p>18 END PANEL</p>  <p>2 PCS</p>	<p>19 LEG</p>  <p>4 PCS</p>	<p>20 LEG SUPPORT</p>  <p>2 PCS</p>

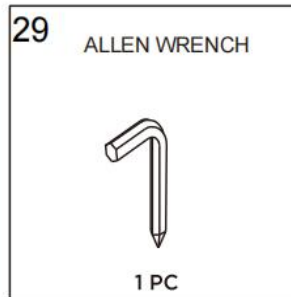
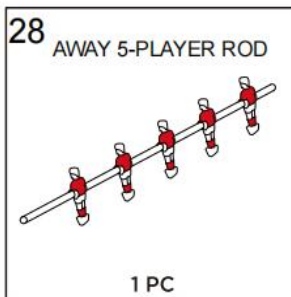
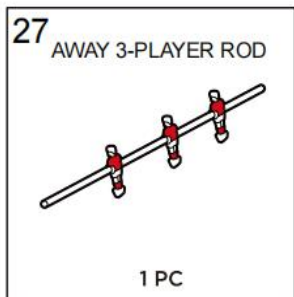
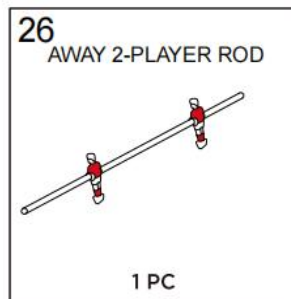
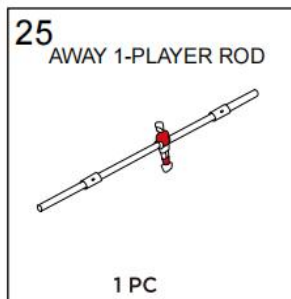
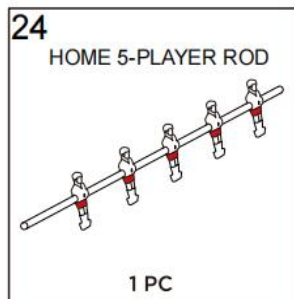
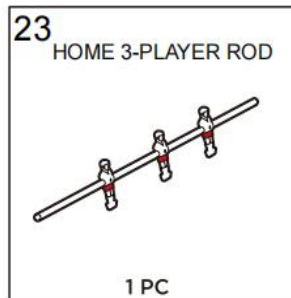
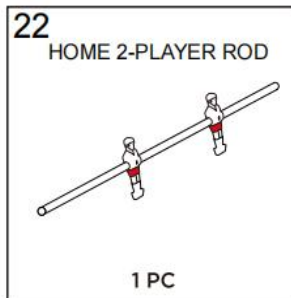
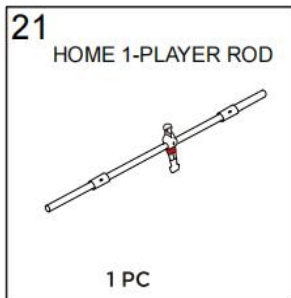

ASSEMBLY INSTRUCTIONS

PASO 1: Coloque un panel lateral de la parte 15 con el orificio de entrada de la bola más cerca del piso. Deslice las varillas del reproductor doméstico de cuatro partes (21-24) con ocho partes 1 espaciadores de goma y ocho parte 2 plastio arandelas en los orificios designados.

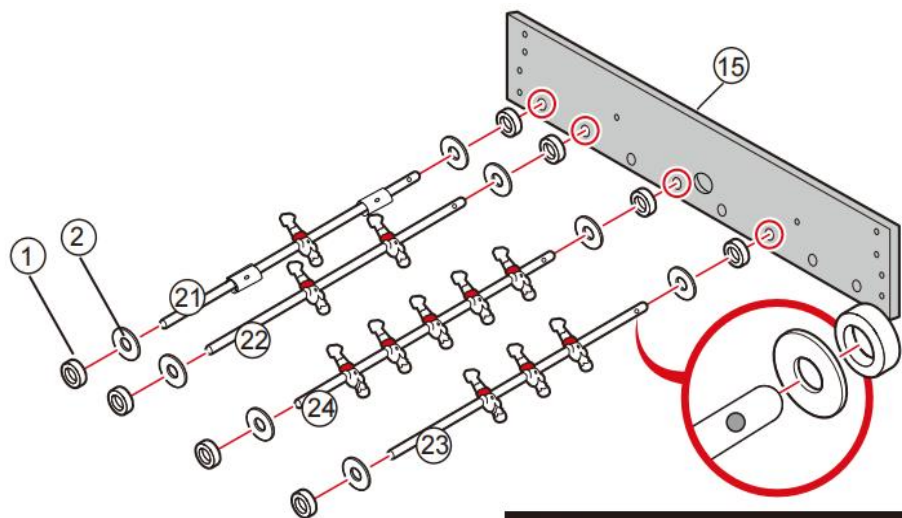

! Make sure that the ends with a hole are arranged on the same side.

PASO 2: Deslice las varillas del reproductor de cuatro partes (25-28) con ocho partes 1 espaciadores de goma y ocho arandelas de plástico parte 2 hacia designada agujeros.

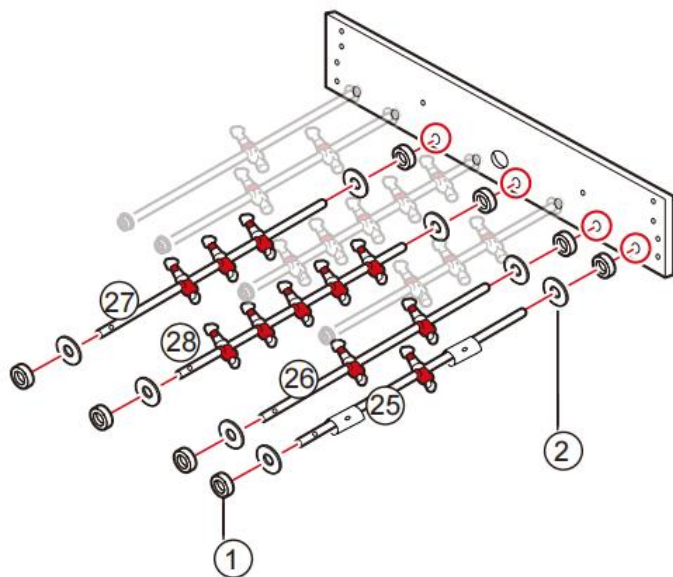

PASO 3: Confirme que las varillas están organizados correctamente y los jugadores en el el mismo equipo se enfrenta al misma dirección.

NOTA: Las figuras y la mesa está al revés en este diagrama .

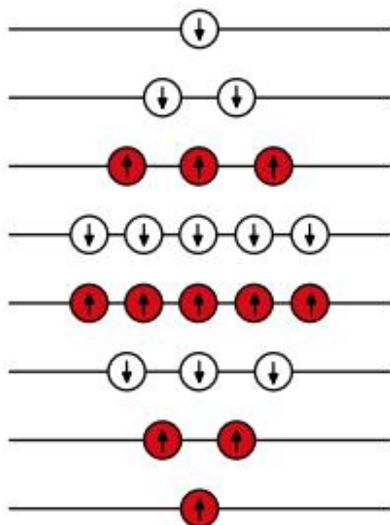

PASO 4: Deslice la otra parte del panel lateral 15 sobre las varillas.

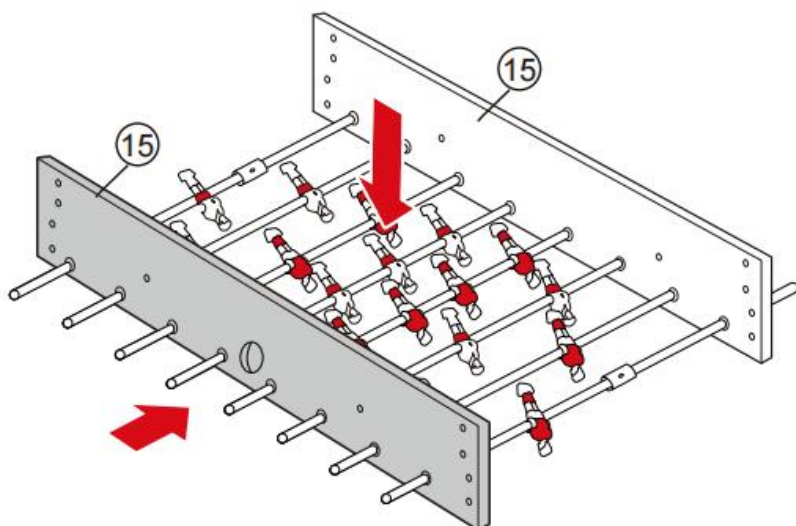

PASO 5: Fije un panel de extremo de la parte 18 con cuatro pernos de la parte 6 y cuatro arandelas de la parte 5. Voltee el campo de juego de la parte 16 boca abajo y deslícelo en las ranuras de los paneles laterales de la parte 15.

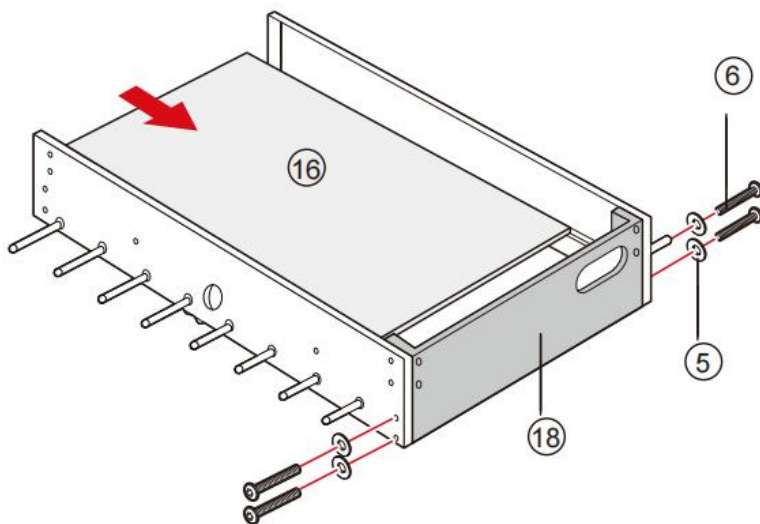

PASO 6: Fije el otro panel de extremo de la parte 18 con cuatro pernos de la parte 6 y cuatro arandelas de la parte 5.

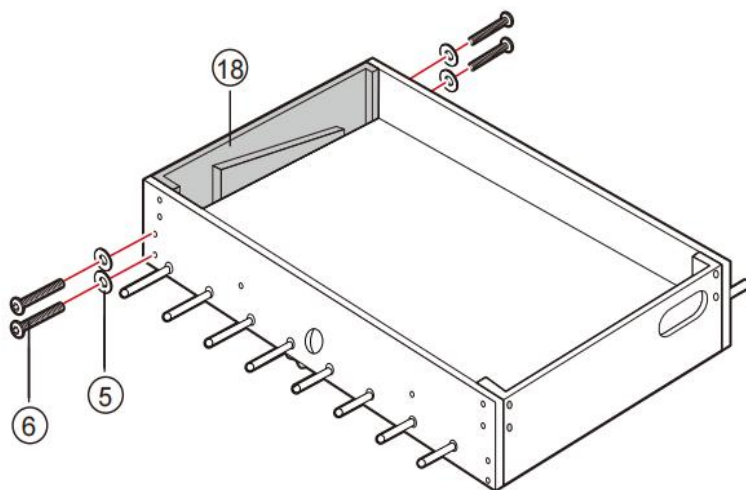

PASO 7: Fije dos soportes de la parte 17 con cuatro tornillos de la parte 3 y cuatro tuercas de la parte 4.

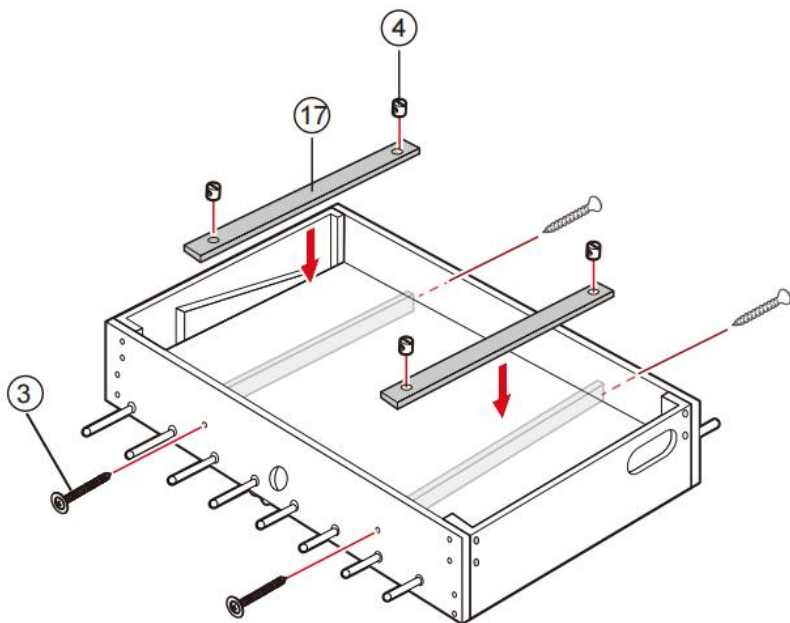

PASO 8: Inserte cuatro patas de la parte 19 en las esquinas. Coloque dos barras de soporte de 20 piezas entre las piernas. Fije las patas con dieciséis pernos de 6 partes y dieciséis arandelas de 5 partes.

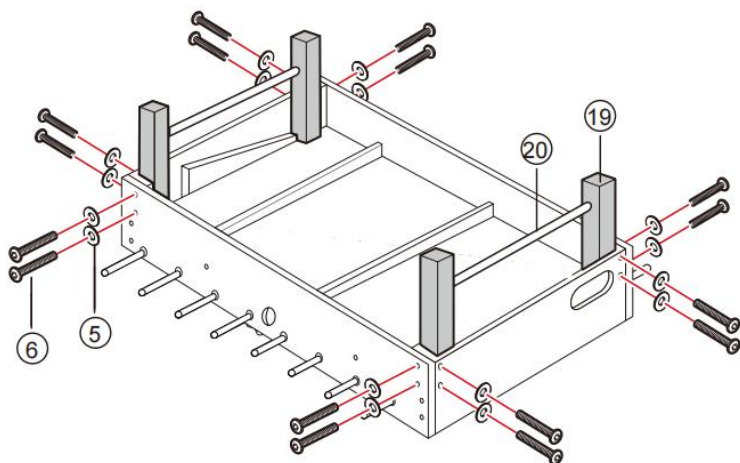

PASO 9: Atornille cuatro pies de 7 partes.

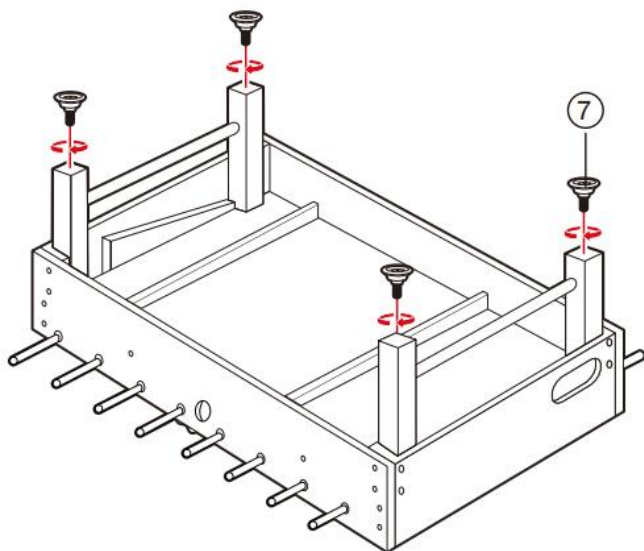

PASO 10: Voltee la mesa con cuidado.

Coloque dos portavasos de la parte 13 con ocho tornillos de la parte 9.

NOTA: No levante la mesa mientras la sujeta por las varillas.

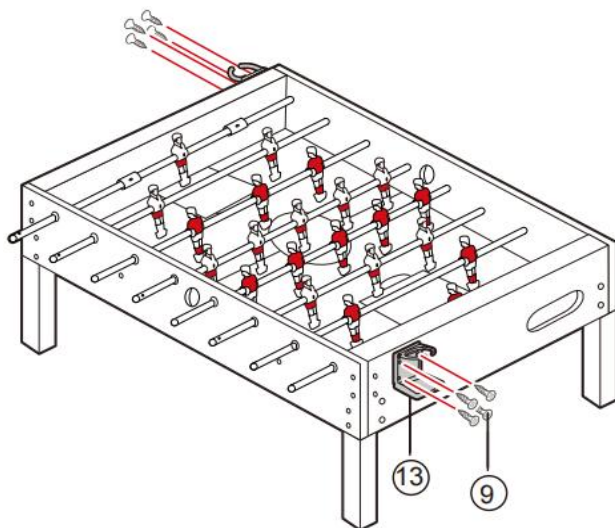

PASO 11: Fije dos anotadores de 14 piezas con cuatro tornillos de 8 piezas.

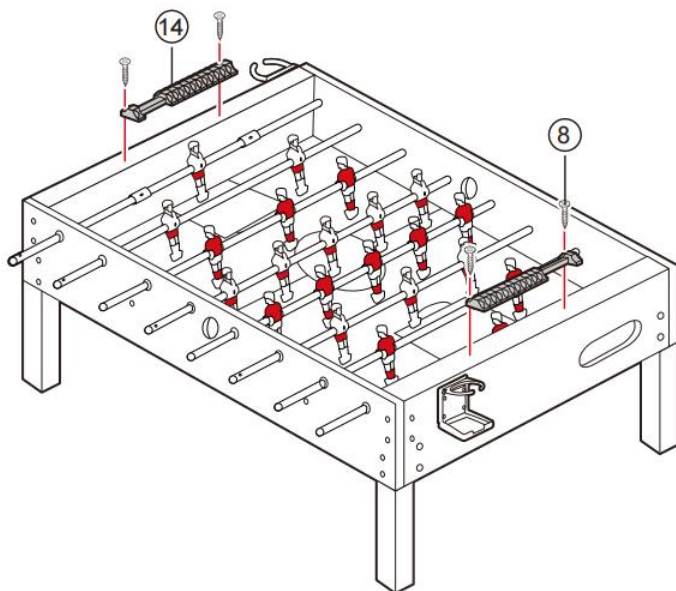

PASO 12: Deslice ocho manijas de la parte 11 en los extremos de las varillas con un orificio
Deslice ocho tapas de extremo de la parte 10 en los extremos de las varillas sin orificio.

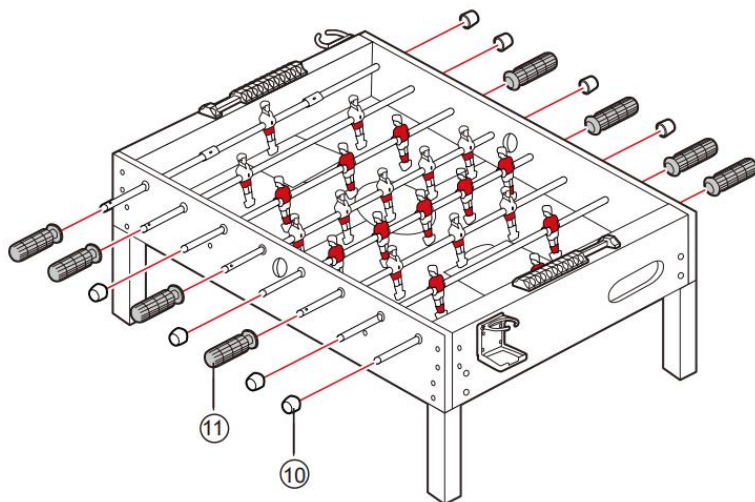

Fabricante: Shanghaimuxinmuyeyouxiangongsi

Dirección: Baoshanqu Shuangchenglu 803long 11hao 1602A-1609shi
Shanghai

Importado a AUS: SIHAO PTY LTD, 1 ROKEVA STREETEASTWOOD
NSW 2122 Australia

Importado a EE. UU.: Sanven Technology Ltd.

Suite 250 , 9166 Anaheim Place, Rancho Cucamonga, CA 91730



SHUNSHUN GmbH
Römeräcker 9 Z2021,76351
Linkenheim-Hochstetten, Germany
euvertreter@gmail.com
+49 1727041930



Pooledas Group Ltd
Unit 5 Albert Edward House, The
Pavilions Preston, United Kingdom
pooledas123@gmail.com
Tel: 01772418127

Hecho en china

VEVOR[®]

TOUGH TOOLS, HALF PRICE

Técnico Certificado de soporte y garantía electrónica

www.vevor.com/support

VEVOR[®]

TOUGH TOOLS, HALF PRICE

Tecnico Supporto e certificato di garanzia elettronica

www.vevor.com/support

CALCIO DA TAVOLO

MODELLO : SUO-4824GW

We continue to be committed to provide you tools with competitive price.

"Save Half", "Half Price" or any other similar expressions used by us only represents an estimate of savings you might benefit from buying certain tools with us compared to the major top brands and does not necessarily mean to cover all categories of tools offered by us. You are kindly reminded to verify carefully when you are placing an order with us if you are actually saving half in comparison with the top major brands.

VEVOR®

TOUGH TOOLS, HALF PRICE

TABLE SOCCER

MODELLO: SUO-4824GW

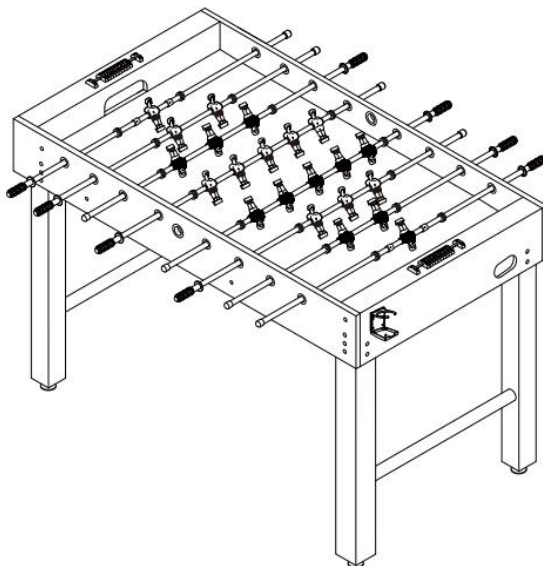

NEED HELP? CONTACT US!

Have product questions? Need technical support? Please feel free to contact us:

Technical Support and E-Warranty Certificate
www.vevor.com/support

This is the original instruction, please read all manual instructions carefully before operating. VEVOR reserves a clear interpretation of our user manual. The appearance of the product shall be subject to the product you received. Please forgive us that we won't inform you again if there are any technology or software updates on our product.



Avvertenza: per ridurre il rischio di lesioni, l'utente deve leggere attentamente il manuale di istruzioni.

SAFETY WARNINGS AND PRECAUTIONS

Grazie per aver utilizzato questo prodotto . Per essere sicuri di poter utilizzare correttamente la macchina, leggere attentamente queste istruzioni prima dell'uso e conservarle adeguatamente per riferimento futuro . Assicurati di leggere le precauzioni e le regole di sicurezza in questa pagina per garantire un utilizzo sicuro . Questo manuale descriverà le avvertenze e le precauzioni di sicurezza, il funzionamento e la manutenzione . Le avvertenze e le istruzioni contenute nel presente manuale non possono coprire tutte le possibili condizioni e situazioni che potrebbero verificarsi . La cautela e il buon senso non sono incorporati in questo prodotto, poiché riteniamo che gli usi saranno conformi a questi codici .

Si prega di leggere TUTTE le istruzioni prima di utilizzare la macchina .

1. Il montaggio deve seguire queste istruzioni. Un montaggio errato può rappresentare un pericolo.
2. Non montare in caso di stanchezza o sotto l'effetto di alcol, droghe o farmaci.
3. Il peso, l'elasticità e le altre proprietà del prodotto si applicano solo ai prodotti correttamente e completamente assemblati.
4. Mantenere l'area di assemblaggio pulita e ben illuminata.
5. Tenere gli astanti lontani dall'area durante il montaggio.
6. Questa è un'attrezzatura, non un giocattolo, deve essere utilizzata sotto la guida di un professionista. Non permettere ai bambini e agli animali domestici di giocare da soli o di avvicinarsi a questo oggetto.
7. Utilizzare solo come previsto. Non sedersi o stare in piedi sul prodotto.
8. Ispezionare prima di ogni utilizzo. Non utilizzarlo se le parti sono allentate o danneggiate.
- 9 . Non utilizzare questa unità per scopi diversi da quelli indicati .

- 1 0 . Non utilizzarlo per scopi commerciali .
- 1 1 . Non pulirlo con materiali abrasivi .
- 1 2 . Non lasciarlo mai incustodito durante l'uso .
- 1 3 . L'urina e le feci degli animali domestici possono danneggiare il prodotto, tenere lontano .
- 1 4 . Non posizionare il prodotto sopra o vicino ad aria calda, fornelli elettrici o stufe .
- 15 . I bambini piccoli devono essere sorvegliati per assicurarsi che non giochino con il prodotto . Gli animali domestici devono stare lontani dal prodotto.



















Non utilizzare all'aperto nelle giornate piovose e nuvolose, evitare fulmini e cadute . Persone o animali appesi al prodotto possono causare lesioni o morte .

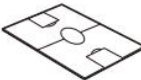

ATTENZIONE: pericolo di soffocamento: il giocattolo contiene palline e/o piccole parti. Non adatto a bambini di età inferiore a 3 anni.

IMPORTANTE! Prima di tentare l'assemblaggio, leggere questo manuale di istruzioni per familiarizzare con tutte le parti e le fasi di assemblaggio. Raccomandiamo che due adulti assemblino questo gioco. Fare riferimento all'elenco delle parti di seguito e assicurarsi che tutte le parti siano state incluse.

PARTS LIST

<p>1 RUBBER SPACER</p>  <p>16 PCS</p>	<p>2 PLASTIC WASHER</p>  <p>16 PCS</p>	<p>3 RWA 3.5X35MM</p>  <p>4 PCS</p>	<p>4 BARREL NUT</p>  <p>4 PCS</p>	<p>5 WASHER</p>  <p>24 PCS</p>
<p>6 TM 6X40MM BOLT</p>  <p>24 PCS</p>	<p>7 FEET</p>  <p>4 PCS</p>	<p>8 FA 3.5X28MM</p>  <p>4 PCS</p>	<p>9 FA 3.5X12MM</p>  <p>8 PCS</p>	<p>10 END CAP</p>  <p>8 PCS</p>
<p>11 HANDLE</p>  <p>8 PCS</p>	<p>12 SOCCER BALL</p>  <p>2 PCS</p>	<p>13 CUP HOLDER</p>  <p>2 PCS</p>	<p>14 SCORER</p>  <p>2 PCS</p>	<p>15 SIDE PANEL</p>  <p>2 PCS</p>
<p>16 PLAYFIELD</p>  <p>1 PC</p>	<p>17 SUPPORT</p>  <p>2 PCS</p>	<p>18 END PANEL</p>  <p>2 PCS</p>	<p>19 LEG</p>  <p>4 PCS</p>	<p>20 LEG SUPPORT</p>  <p>2 PCS</p>

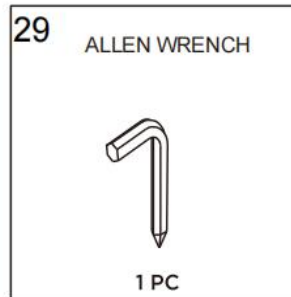
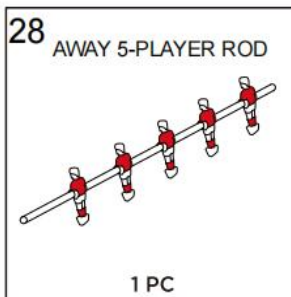
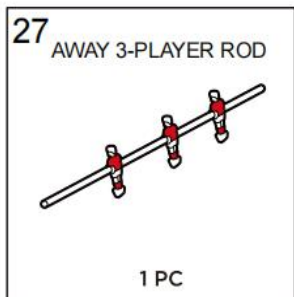
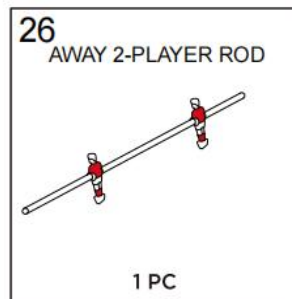
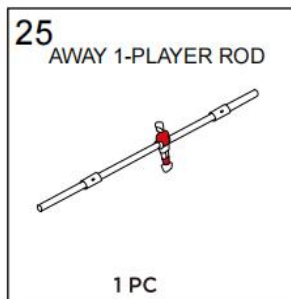
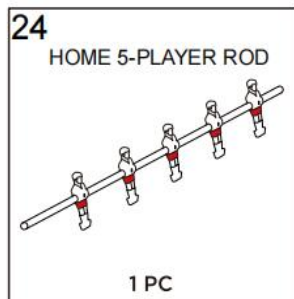
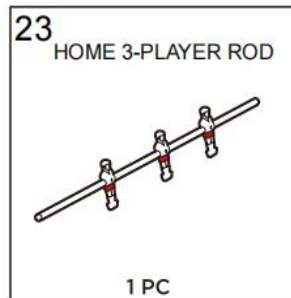
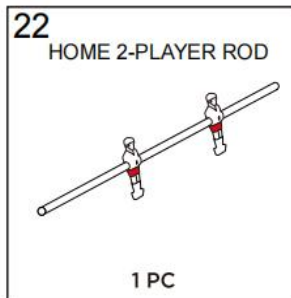
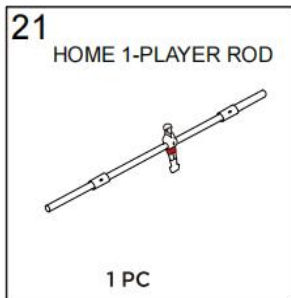

ASSEMBLY INSTRUCTIONS

PASSO 1: Posiziona un pannello laterale della parte 15 con il foro di ingresso della palla più vicino al pavimento. Fai scorrere le aste del giocatore di casa in quattro parti (21-24) con l'ottava parte 1 distanziatori in gomma e otto parti 2 plastio rondelle nei fori designati.

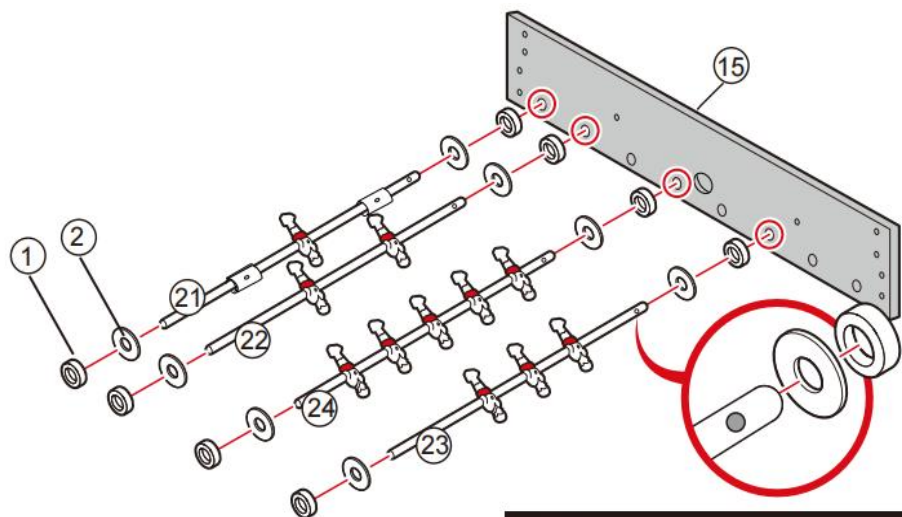

! Make sure that the ends with a hole are arranged on the same side.

FASE 2: fai scorrere le aste del giocatore in trasferta in quattro parti (25-28) con otto parti 1 distanziatori in gomma e rondelle in plastica in otto parti 2 al designato buchi.

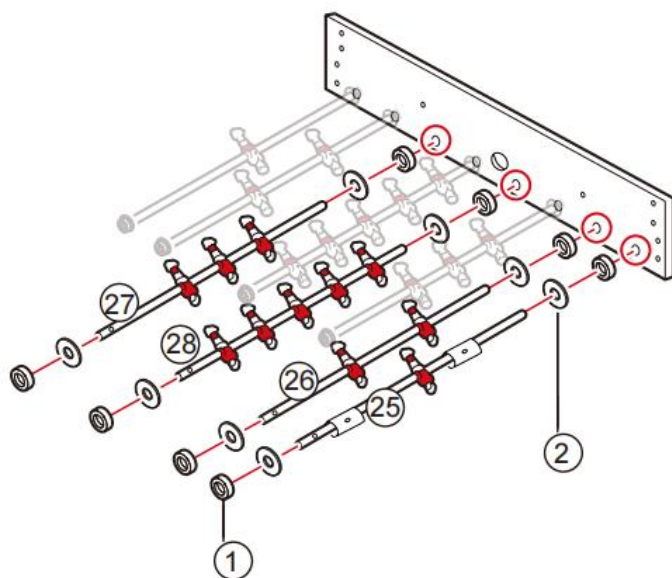

STEP3: Confermare che le aste sono disposti correttamente e i giocatori sul stessa squadra affronta la stessa direzione.

NOTA: le cifre e il tavolo è capovolto questo diagramma .

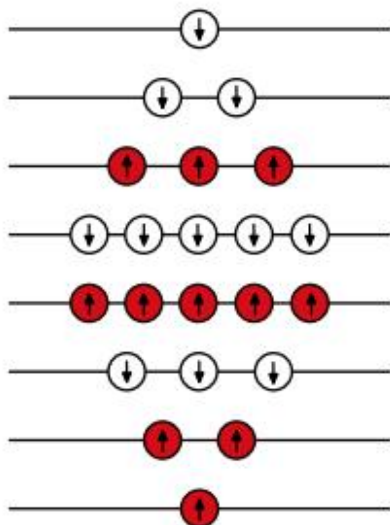

FASE 4: far scorrere l'altra parte 15 del pannello laterale sulle aste.

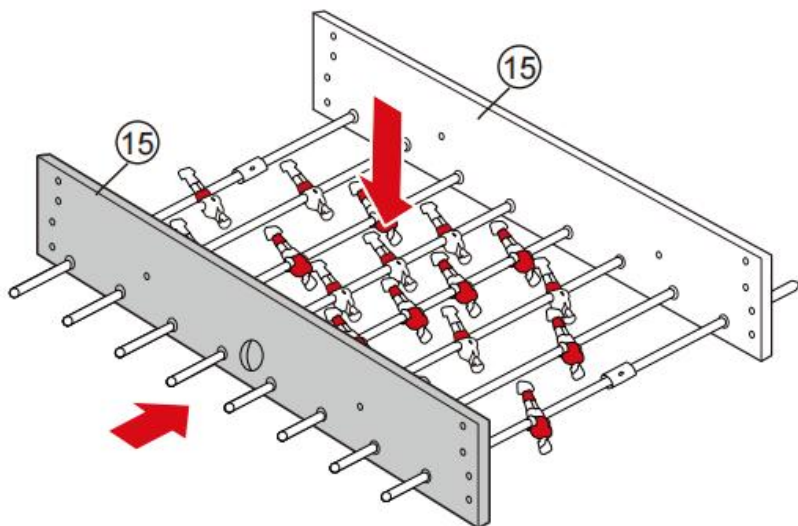

PASSO 5: collega un pannello terminale della parte 18 con quattro bulloni della parte 6 e quattro rondelle della parte 5. Capovolgi il piano di gioco della parte 16 sottosopra e inseriscilo nelle fessure dei pannelli laterali della parte 15.

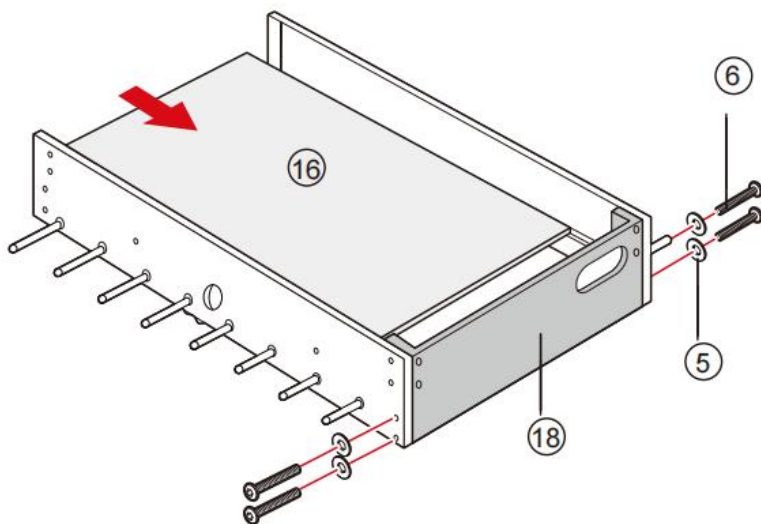

PASSO 6: Fissare l'altro pannello terminale della parte 18 con quattro bulloni parte 6 e quattro rondelle parte 5.

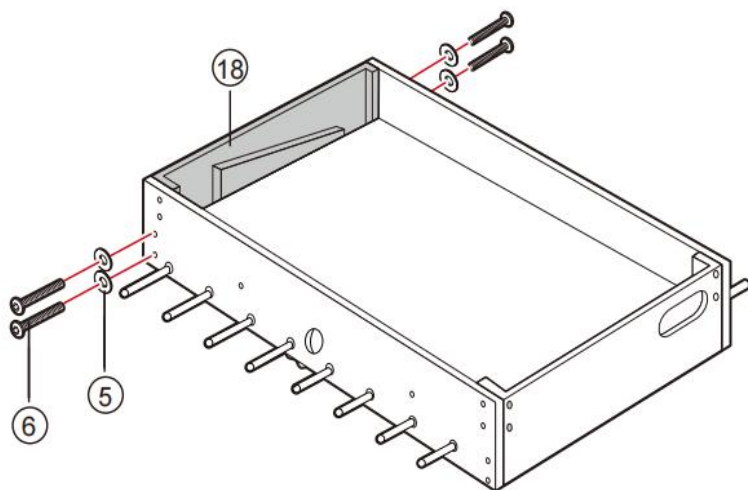

PASSO 7: Fissare due supporti parte 17 con quattro viti parte 3 e quattro dadi parte 4.

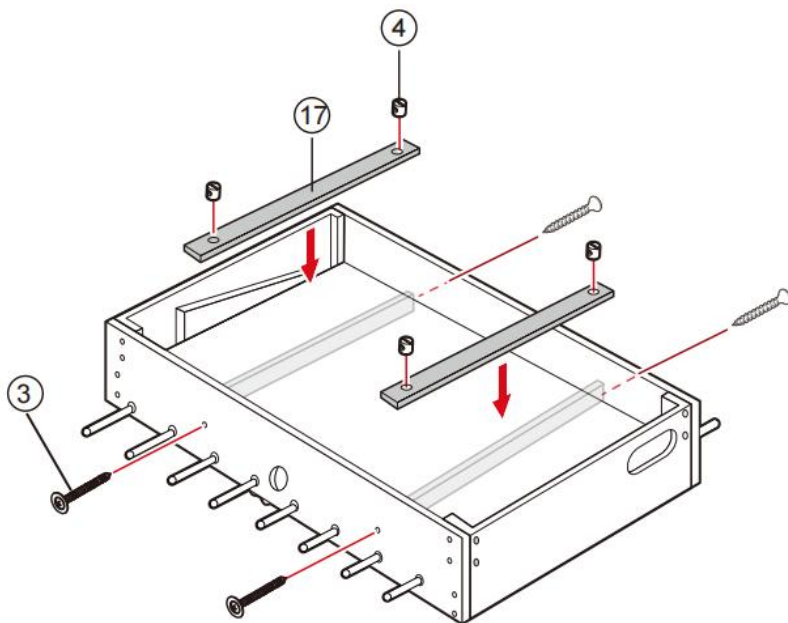

PASSO 8: Inserisci le quattro gambe da 19 parti negli angoli. Posizionare due barre di supporto da 20 parti tra le gambe. Fissare le gambe con sedici bulloni parte 6 e sedici rondelle parte 5.

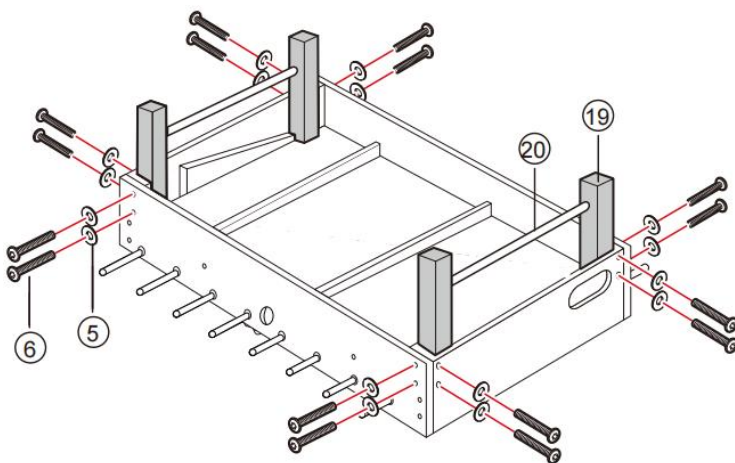

PASSO 9: Avvitare in quattro parti 7 piedi.

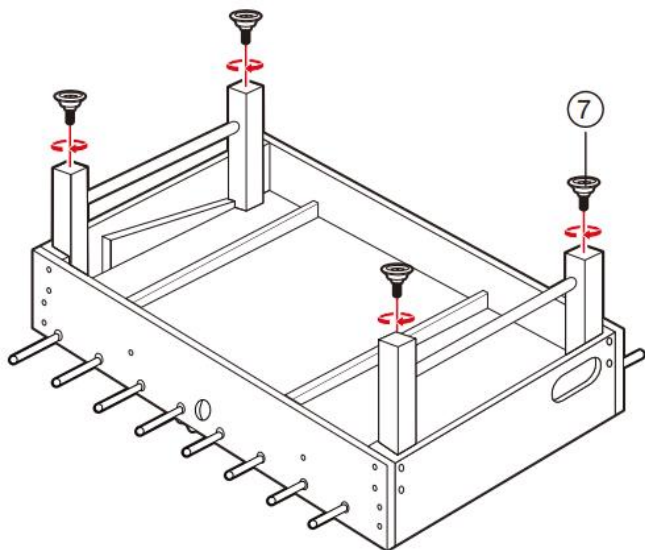

PASSO 10: Capovolgi con attenzione il tavolo.

Fissare i portabicchieri in due parti 13 con otto viti in parte 9.

NOTA: non sollevare il tavolo tenendolo alle aste.

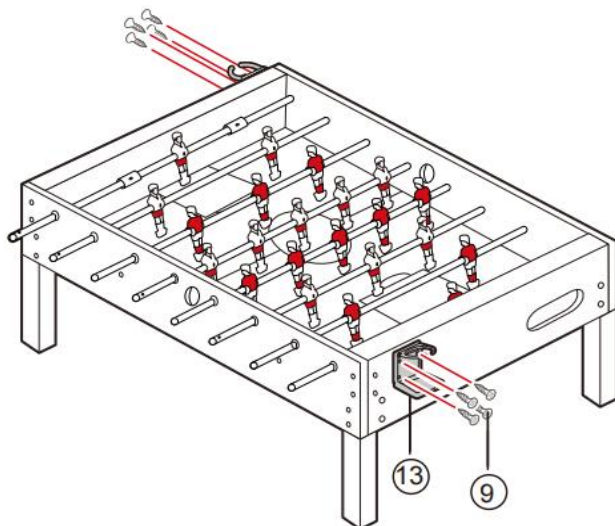

PASSO 11: Fissare due marcatori parte 14 con quattro viti parte 8.

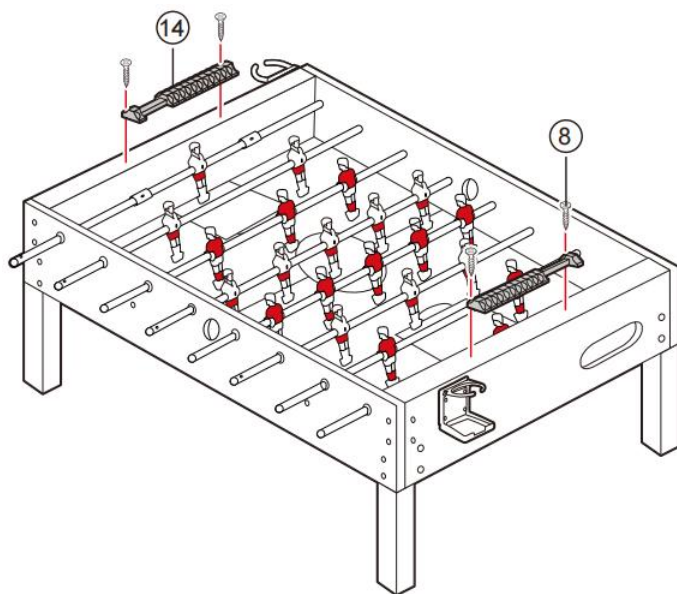

PASSO 12: fai scorrere le otto maniglie della parte 11 sulle estremità delle aste con un foro

Far scorrere i cappucci terminali in otto parti da 10 sulle estremità delle aste senza foro.

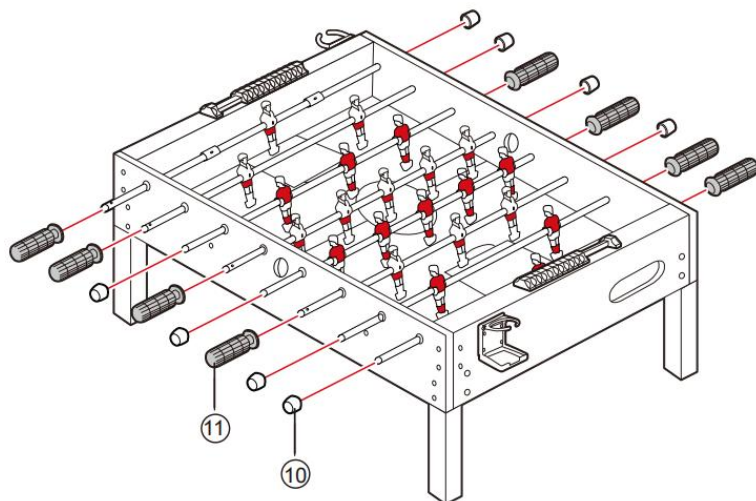

Produttore: Shanghaimuxinmuyeyouxiangongsi

Indirizzo: Baoshanqu Shuangchenglu 803long 11hao 1602A-1609shi
Shanghai

Importato in AUS: SIHAO PTY LTD, 1 ROKEVA STREETEASTWOOD
NSW 2122 Australia

Importato negli Stati Uniti: Sanven Technology Ltd.
Suite 250 , 9166 Anaheim Place, Rancho Cucamonga, CA 91730



SHUNSHUN GmbH
Römeräcker 9 Z2021,76351
Linkenheim-Hochstetten, Germany
euvertreter@gmail.com
+49 1727041930



Pooledas Group Ltd
Unit 5 Albert Edward House, The
Pavilions Preston, United Kingdom
pooledas123@gmail.com
Tel: 01772418127

Made in China

VEVOR[®]

TOUGH TOOLS, HALF PRICE

Tecnico Supporto e certificato di garanzia elettronica

www.vevor.com/support