

VEVOR[®]

TOUGH TOOLS, HALF PRICE

Technical Support and E-Warranty Certificate

www.vevor.com/support

Arm Preacher Curl Weight Station

MODEL:qb035

We continue to be committed to provide you tools with competitive price. "Save Half", "Half Price" or any other similar expressions used by us only represents an estimate of savings you might benefit from buying certain tools with us compared to the major top brands and does not necessarily mean to cover all categories of tools offered by us. You are kindly reminded to verify carefully when you are placing an order with us if you are actually Saving Half in comparison with the top major brands.

VEVOR®

TOUGH TOOLS, HALF PRICE

Arm Preacher Curl Weight Station

MODEL: qb035

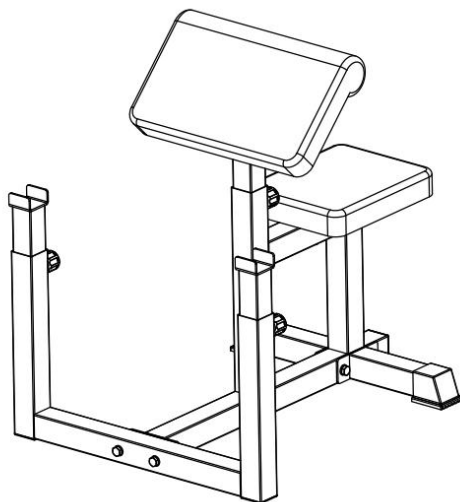

Note: The product picture is for reference, the actual details shall prevail

NEED HELP? CONTACT US!

Have product questions? Need technical support? Please feel free to contact us:

Technical Support and E-Warranty Certificate
www.vevor.com/support

This is the original instruction, please read all manual instructions carefully before operating. VEVOR reserves a clear interpretation of our user manual. The appearance of the product shall be subject to the product you received. Please forgive us that we won't inform you again if there are any technology or software updates on our product.

Operation safety



WARNING:

Please read all instructions before using this product

It is the Owner's responsibility to ensure that all users of this product are fully aware of all warnings and precautions.

- Do not use it if you are pregnant
- Please install strictly according to the instructions
- To ensure user safety, please check whether all screws and other connecting parts on the device are intact before each use
- Incorrect or excessive intensity exercise is not good for health. It is recommended to consult a doctor before exercising
- It is best to wear sportswear and sports shoes when exercising
- If you feel dizziness, vomiting or other adverse symptoms during exercise, you should stop training immediately.
- Children and disabled people can only use it under the supervision of relevant personnel.
- Note that all screws and nuts must be tightened before
- Please do not exercise half an hour before /after meals or 1 hour before sleep
- Please make exercise plans.
- The user's weight cannot exceed 440lbs





ASSEMBLE CAUTION

Before beginning assembly, carefully read the following information and instructions:

- Assembly requires two people.
- Place all parts in a cleared area and remove the packing materials. Do not dispose of the packing materials until assembly is completed.
- Tighten all parts as you assemble them, unless instructed to do otherwise.











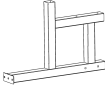



- As you assemble the weight system, make sure all parts are oriented as shown in the drawings.

The following tools (not included) are required for assembly:







- Two adjustable wrenches 
- One rubber mallet 
- One standard screwdriver 
- One Phillips screwdriver 
- Lubricant, such as grease or petroleum jelly, and soapy water.

Assembly will be more convenient if you have a socket set, a set of open-end or closed-end wrenches, or a set of ratchet wrenches.

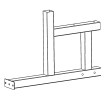
PARTS LIST



1  1PCS	2  1PCS	3  2PCS	4  1PCS	5  2PCS
6  1PCS	7  1PCS	8  3PCS	9 M10X70  4PCS	10 M8X60  2PCS
11 M8X15  2PCS	12 M10  8PCS	13 M8  4PCS	14 M10  4PCS	

Step 1

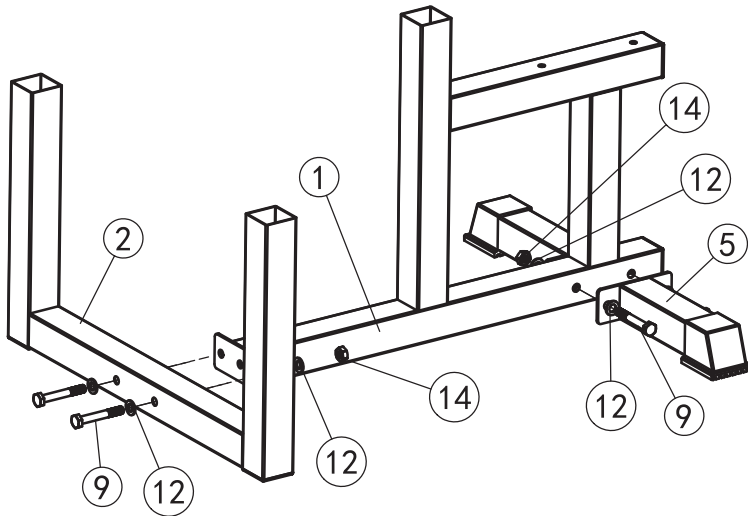
<p>1</p>  <p>1PCS</p>	<p>2</p>  <p>1PCS</p>	<p>5</p>  <p>2PCS</p>	<p>4</p>  <p>1PCS</p>	<p>9 M10X70</p>  <p>4PCS</p>
<p>12 M10</p>  <p>8 PCS</p>	<p>14 M10</p>  <p>4PCS</p>			





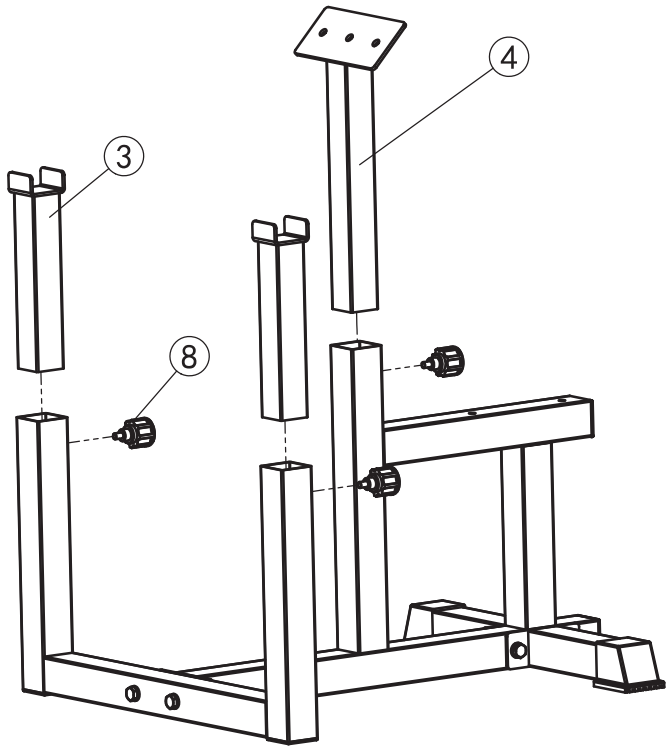

Step 2

<p>3</p>  <p>2PCS</p>	<p>4</p>  <p>1PCS</p>	<p>8</p>  <p>3PCS</p>		
---	---	---	--	--

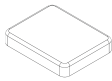

Step 3

6  1PCS	7  6PCS	10 M8X60  2PCS	11 M8X15  2PCS	13 M8  4PCS
---	---	--	--	---

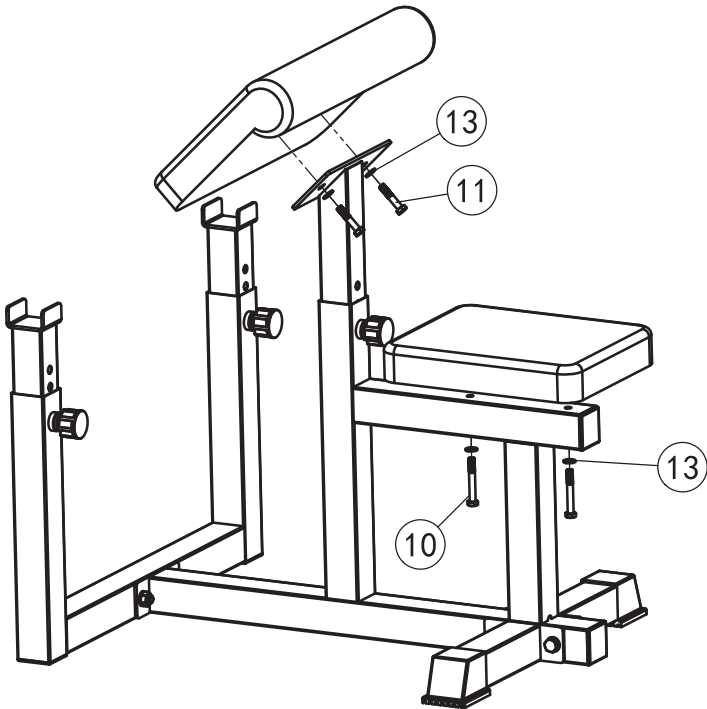

Manufacturer: Shanghaimuxinmuyeyouxiangongsi

Address: Shuangchenglu 803nong11hao1602A-1609shi, baoshanqu, shanghai 200000 CN.

Imported to AUS: SIHAO PTY LTD. 1 ROKEVA STREETEASTWOOD NSW 2122 Australia

Imported to USA: Sanven Technology Ltd. Suite 250, 9166 Anaheim Place, Rancho Cucamonga, CA 91730

UK	REP
-----------	------------

YH CONSULTING LIMITED. C/O YH Consulting Limited Office 147, Centurion House, London Road, Staines-upon-Thames, Surrey, TW18 4AX

EC	REP
-----------	------------

E-CrossStu GmbH
Mainzer Landstr.69,
60329 Frankfurt am Main.

VEVOR®

TOUGH TOOLS, HALF PRICE

Technical Support and E-Warranty Certificate

www.vevor.com/support

Sécurité de fonctionnement

AVERTISSEMENT:

Veuillez lire toutes les instructions avant d'utiliser ce produit

Il est de la responsabilité du propriétaire de s'assurer que tous les utilisateurs de ce produit sont pleinement conscients de tous les avertissements et précautions.

- Ne l'utilisez pas si vous êtes enceinte •

Veuillez l'installer strictement selon les instructions • Pour assurer la

sécurité de l'utilisateur, veuillez vérifier si toutes les vis et autres pièces de connexion de l'appareil sont intactes avant chaque utilisation. Un exercice incorrect ou

- d'intensité excessive n'est pas bon pour **la santé**. Il est recommandé de consulter un médecin avant de faire de l'exercice. Il est préférable de porter

- des vêtements de sport et des chaussures de sport lors de l'exercice. Si vous

- ressentez des étourdissements, des vomissements ou d'autres symptômes indésirables pendant l'exercice, vous devez arrêter immédiatement l'entraînement.

- Les enfants et les personnes handicapées ne peuvent l'utiliser que sous la surveillance du personnel compétent. •

Veuillez noter que toutes les vis et tous les écrous doivent être serrés

avant • Veuillez ne pas faire d'exercice une demi-heure avant/après les repas ou 1 heure

avant de dormir

- Veuillez prévoir des exercices. • Le poids

de l'utilisateur ne peut pas dépasser 440 lb

ASSEMBLAGE ATTENTION

Avant de commencer l'assemblage, lisez attentivement les informations et instructions suivantes :

- L'assemblage nécessite deux personnes. •

Placez toutes les pièces dans une zone dégagée et retirez les matériaux d'emballage. Ne jetez pas les matériaux d'emballage avant la fin de l'assemblage.

- Serrez toutes les pièces au fur et à mesure que vous les assemblez, sauf indication contraire. sinon.

- Lorsque vous assemblez le système de poids, assurez-vous que toutes les pièces sont orientées comme indiqué sur les dessins.

Les outils suivants (non inclus) sont nécessaires pour l'assemblage : • Deux clés à molette • Un maillet en caoutchouc

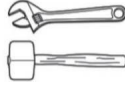









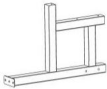





- Un tournevis standard --- ----- (=■) • Un tournevis cruciforme — • Du lubrifiant, tel que de la graisse ou de la vaseline, et de l'eau savonneuse.







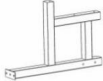

L'assemblage sera plus pratique si vous disposez d'un jeu de douilles, d'un jeu de clés plates ou fermées, ou d'un jeu de clés à cliquet.

LISTE DES PIÈCES



1  1PCS	2  1PCS	3  2PCS	4  1PCS	5  2PCS
6  1PCS	7  1PCS	8  3PCS	9 M10X70  4PCS	10 M8X60  2PCS
11 M8X15  2PCS	12 M10  8PCS	13 M8  4PCS	14 M10  4PCS	

Étape 1

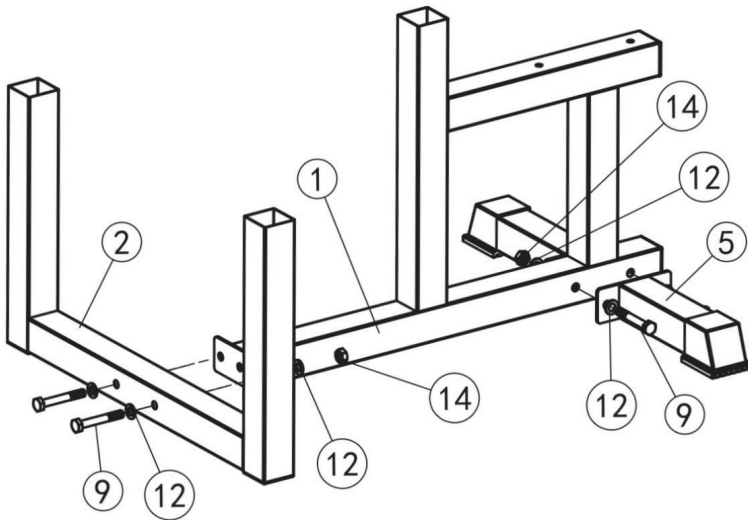
1  1PCS	2  1PCS	5  2PCS	4  1PCS	9 M10X70  4PCS
12 M10  8 PCS	14 M10  4PCS			





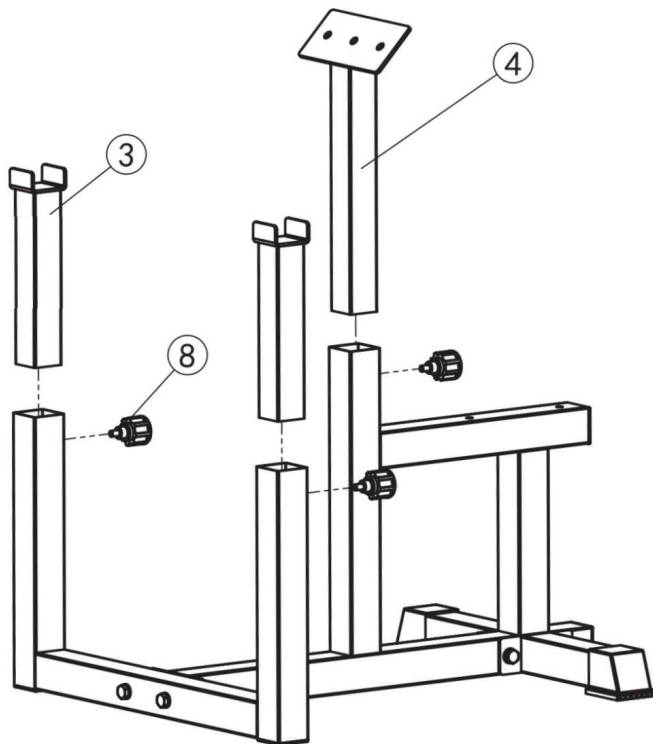

Étape 2

<p>3</p>  <p>2 pièces</p>	<p>4</p>  <p>J</p> <p>1 pièce</p>	<p>8</p>  <p>3 pièces</p>		
--	--	--	--	--



Étape 3

6  1PCS	7  6PCS	10 M8X60  2PCS	11 M8X15  2PCS	13 M8  4PCS
---	---	--	--	---

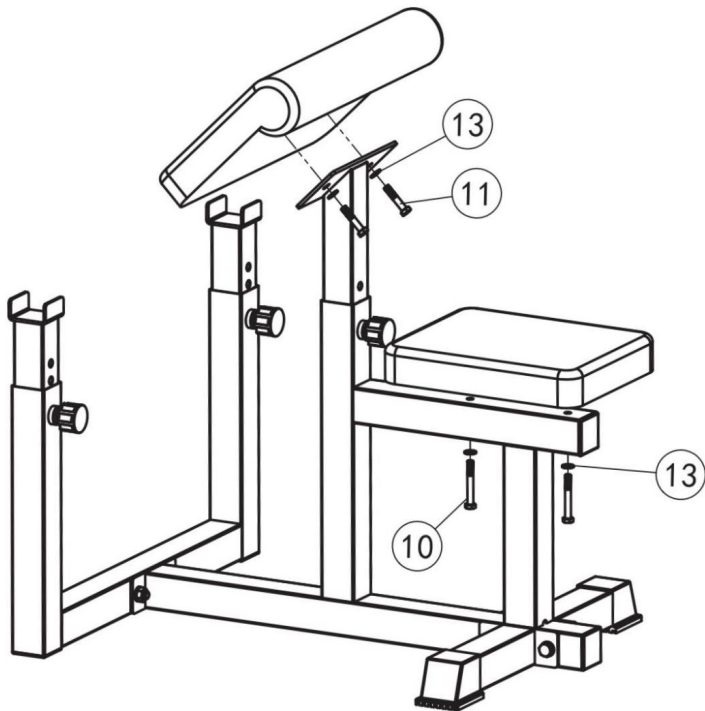

Fabricant : Shanghaimuxinmuyeyouxiangongsi Adresse :

Shuangchenglu 803nong11 hao1602A-1609shi, baoshanqu, shanghai 200000 CN.

Importé en AUS : SI HAO PTY LTD. 1 ROKEVA STREETEASTWOOD NSW2122 Australie

Importé aux USA :

Sanven Technology Ltd. Suite 250, 9166 Anaheim Place, Rancho Cucamonga, CA91730

REPRÉSENTANT DU ROYAUME-UNI	
REPRÉSENTANT DE LA CE	

YH CONSULTING LIMITED. C/O YH Consulting Limited

Bureau 147, Centurion House, London Road, Staines-upon-Thames, Surrey, TW18 4AX

E-CrossStu GmbH

Mainzer Landstr.69,
60329 Francfort-sur-le-Main.

Betriebssicherheit

WARNUNG:

Bitte lesen Sie alle Anweisungen, bevor Sie dieses Produkt verwenden

Es liegt in der Verantwortung des Eigentümers, sicherzustellen, dass alle Benutzer dieses Produkts über alle Warnungen und Vorsichtsmaßnahmen informiert sind.

- Verwenden Sie es nicht, wenn Sie schwanger sind.
- Installieren Sie es bitte streng nach den Anweisungen.
- Um die Sicherheit des Benutzers zu gewährleisten, überprüfen Sie vor jedem Gebrauch, ob alle Schrauben und anderen Verbindungsteile am Gerät intakt sind. Falsches oder übermäßig intensives Training ist nicht gut für [die Gesundheit](#). Es wird empfohlen, vor dem [Training](#) einen Arzt aufzusuchen. Tragen Sie beim Training am besten Sportbekleidung und Sportschuhe. Wenn Sie während des Trainings Schwindel, Erbrechen oder andere widrige Symptome verspüren, sollten Sie das Training sofort abbrechen.
- Kinder und Behinderte dürfen das Gerät nur unter Aufsicht des entsprechenden Personals benutzen.
- Beachten Sie, dass alle Schrauben und Muttern vor dem Training festgezogen werden müssen.
- Bitte trainieren Sie eine halbe Stunde vor/nach den Mahlzeiten oder 1 Stunde vor dem Schlafengehen.
- Bitte machen Sie Trainingspläne.
- Das Gewicht des Benutzers darf 200 kg nicht überschreiten.

MONTAGE ACHTUNG

Lesen Sie vor Beginn der Montage die folgenden Informationen und Anweisungen sorgfältig durch:

- Für die Montage sind zwei Personen erforderlich.
- Legen Sie alle Teile auf einen freien Platz und entfernen Sie das Verpackungsmaterial. Entsorgen Sie das Verpackungsmaterial erst, wenn die Montage abgeschlossen ist.
- Ziehen Sie alle Teile beim Zusammenbau fest, es sei denn, Sie werden dazu aufgefordert. ansonsten.

- Achten Sie beim Zusammenbau des Gewichtssystems darauf, dass alle Teile wie in den Zeichnungen gezeigt ausgerichtet sind.

Für die Montage werden folgende Werkzeuge (nicht im Lieferumfang enthalten)

benötigt: • Zwei verstellbare



Schraubenschlüssel • Ein Gummihammer



• Ein Standardschraubendreher --- ---- (⇒) • Ein











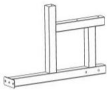



Kreuzschlitzschraubendreher — •









Schmiermittel, beispielsweise Fett oder Vaseline, und Seifenwasser.

Die Montage gestaltet sich einfacher, wenn Sie über einen Steckschlüsselsatz, einen Satz Maul- oder Ringschlüssel oder einen Satz Ratschenschlüssel verfügen.

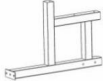
TEILELISTE



1  1PCS	2  1PCS	3  2PCS	4  1PCS	5  2PCS
6  1PCS	7  1PCS	8  3PCS	9 M10X70  4PCS	10 M8X60  2PCS
11 M8X15  2PCS	12 M10  8PCS	13 M8  4PCS	14 M10  4PCS	

Schritt 1

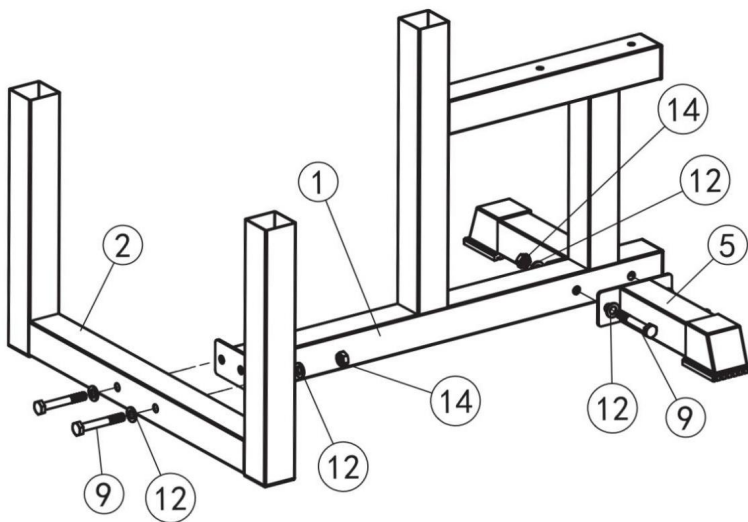
1  1PCS	2  1PCS	5  2PCS	4  1PCS	9 M10X70  4PCS
12 M10  8 PCS	14 M10  4PCS			





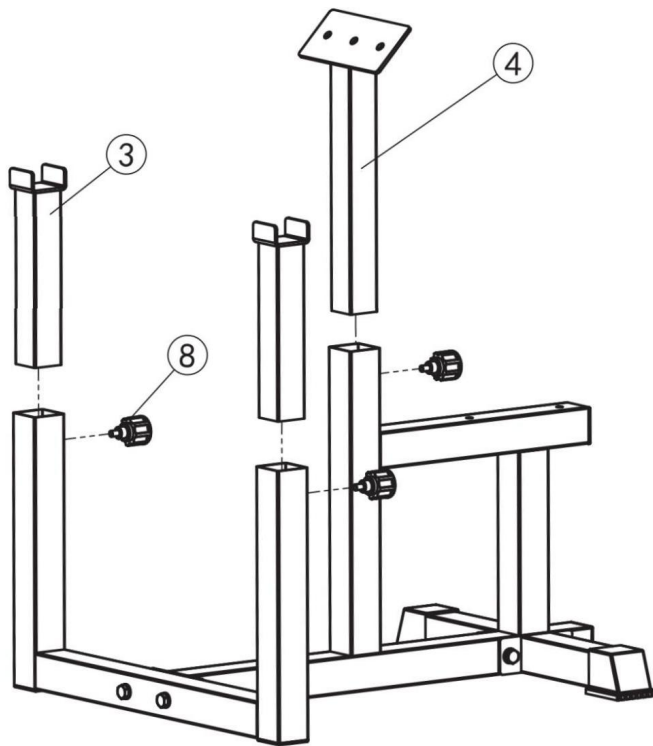

Schritt 2

<p>3</p>  <p>2 STK</p>	<p>4</p>  <p>1 STÜCK</p>	<p>8</p>  <p>3 STK</p>		
---	---	---	--	--



Schritt 3

6  1PCS	7  6PCS	10 M8X60  2PCS	11 M8X15  2PCS	13 M8  4PCS
---	---	--	--	---

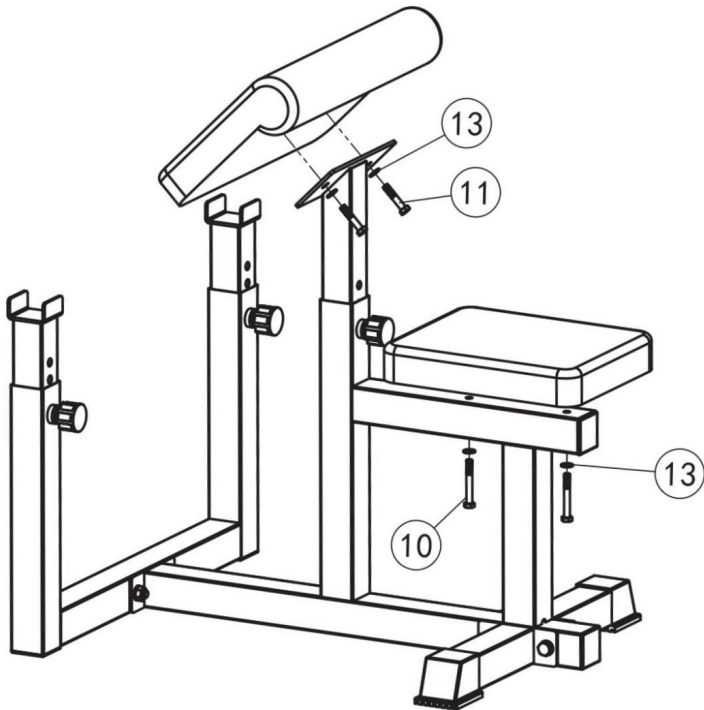

Hersteller: Shanghaimuxinmuyeyouxiangongsi **Adresse:**

Shuangchenglu 803nong11 hao1602A-1609shi, baoshanqu, Shanghai 200000 CN.

Importiert nach AUS: SI HAO PTY LTD. 1 ROKEVA STREETEASTWOOD NSW2122
Australien **Importiert**

nach USA: Sanven Technology Ltd. Suite 250, 9166 Anaheim Place, Rancho
Cucamonga, CA91730

UK REP	
Vertreter der EG	

YH CONSULTING LIMITED. C/O YH Consulting Limited
Office 147, Centurion House, London Road, Staines-
upon-Thames, Surrey, TW18 4AX

E-CrossStu GmbH
Mainzer Landstr.69,
60329 Frankfurt am Main.

Sicurezza operativa

AVVERTIMENTO:

Si prega di leggere tutte le istruzioni prima di utilizzare questo prodotto

È responsabilità del proprietario garantire che tutti gli utenti di questo prodotto siano pienamente consapevoli di tutte le avvertenze e precauzioni.

- Non utilizzarlo in caso di gravidanza • Installare seguendo rigorosamente le istruzioni • Per garantire la sicurezza dell'utente, verificare che tutte le viti e le altre parti di collegamento del dispositivo siano intatte prima di ogni utilizzo L'esercizio fisico scorretto o di intensità eccessiva non fa bene alla [salute](#).
 - Si consiglia di consultare un medico prima di fare esercizio fisico. È meglio indossare abbigliamento sportivo e scarpe sportive durante l'esercizio fisico. Se
 - durante l'esercizio si avvertono vertigini, vomito o altri sintomi avversi, è necessario
 - interrompere immediatamente l'allenamento.
- I bambini e le persone disabili possono utilizzarlo solo sotto la supervisione del personale addetto. • Si prega di notare che tutte le viti e i dadi devono essere serrati prima • Si prega di non esercitarsi mezz'ora prima/dopo i pasti o 1 ora prima di dormire
- Si prega di pianificare gli esercizi. • Il peso dell'utente non può superare le 440 libbre

ATTENZIONE AL MONTAGGIO

Prima di iniziare il montaggio, leggere attentamente le seguenti informazioni e istruzioni:

- Il montaggio richiede due persone. • Collocare tutte le parti in un'area sgombra e rimuovere i materiali di imballaggio. Non smaltire i materiali di imballaggio fino al completamento del montaggio.
- Stringere tutte le parti durante l'assemblaggio, a meno che non venga espressamente richiesto Altrimenti.

- Durante il montaggio del sistema di pesi, assicurarsi che tutte le parti siano orientate come mostrato nei disegni.

Per il montaggio sono necessari i seguenti utensili (non inclusi):

- Due chiavi inglesi regolabili
- Un martello di gomma

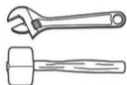









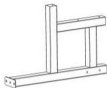

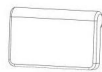

- Un cacciavite standard --- ----- (=ÿ)
- Un cacciavite a croce —
- Lubrificante, come grasso o vaselina, e acqua saponata.







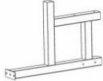

Il montaggio sarà più comodo se si dispone di un set di bussole, di un set di chiavi a forchetta o a forchetta chiusa oppure di un set di chiavi a cricchetto.

ELENCO DELLE PARTI



1  1PCS	2  1PCS	3  2PCS	4  1PCS	5  2PCS
6  1PCS	7  1PCS	8  3PCS	9 M10X70  4PCS	10 M8X60  2PCS
11 M8X15  2PCS	12 M10  8PCS	13 M8  4PCS	14 M10  4PCS	

Passo 1

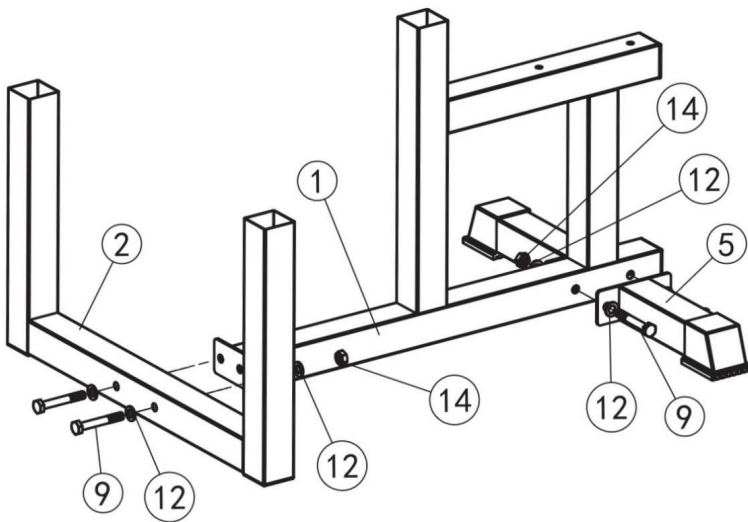
1  1PCS	2  1PCS	5  2PCS	4  1PCS	9 M10X70  4PCS
12 M10  8 PCS	14 M10  4PCS			





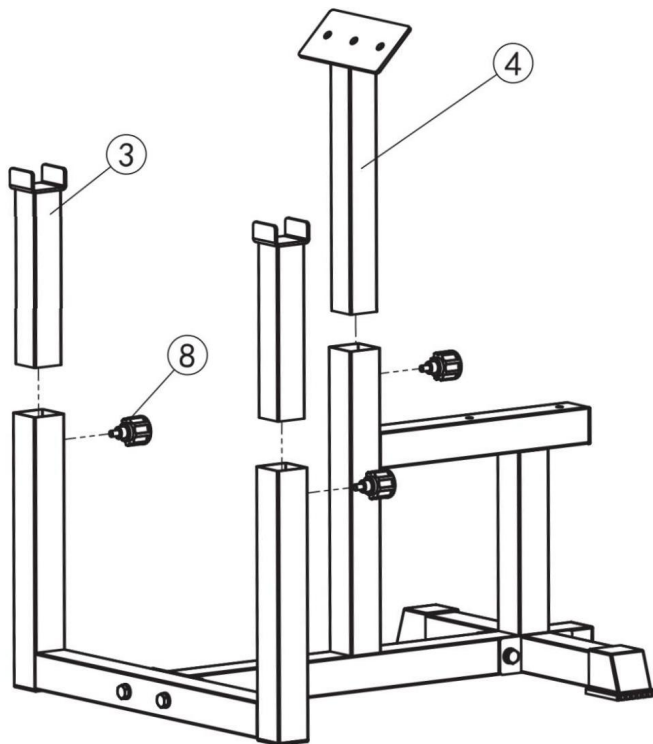

Passo 2

<p>3</p>  <p>2 PZ</p>	<p>4</p>  <p>1 PZ</p>	<p>8</p>  <p>3 PZ</p>		
--	--	--	--	--



Passo 3

6  1PCS	7  6PCS	10 M8X60  2PCS	11 M8X15  2PCS	13 M8  4PCS
---	---	--	--	---

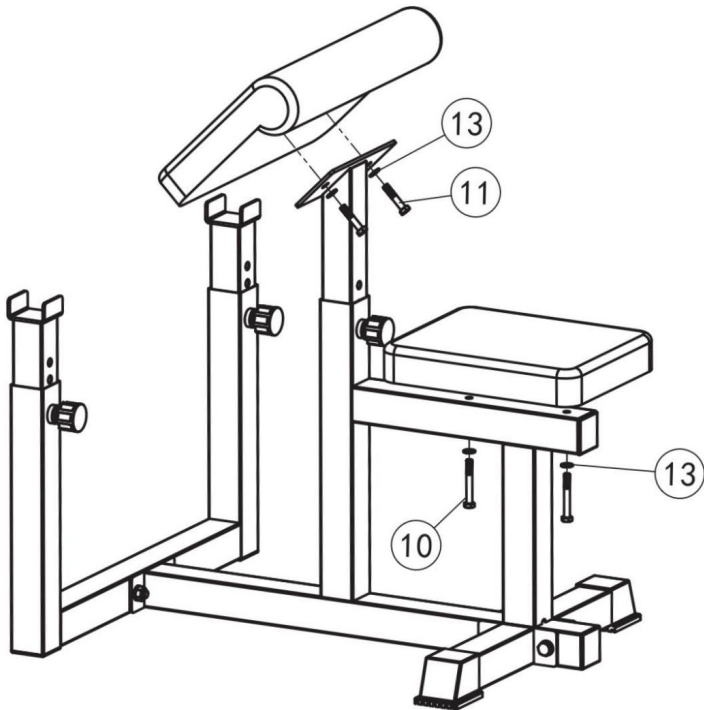

Produttore: Shanghaimuxinmuyeyouxiangongsi **Indirizzo:**

Shuangchenglu 803nong11 hao1602A-1609shi, baoshanqu, shanghai 200000 CN.

Importato in AUS: SI HAO PTY LTD. 1 ROKEVA STREETEASTWOOD NSW2122
Australia **Importato in**

USA: Sanven Technology Ltd. Suite 250, 9166 Anaheim Place, Rancho Cucamonga,
CA91730

RAPPRESENTANZA DEL REGNO UNITO	
Rappresentante della CE	

YH CONSULTING LIMITED. C/O YH Consulting Limited
Ufficio 147, Centurion House, London Road, Staines-
upon-Thames, Surrey, TW18 4AX

E-CrossStu GmbH
Mainzer Landstr.69,
60329 Francoforte sul Meno.

Seguridad de operación

ADVERTENCIA:

Lea todas las instrucciones antes de utilizar este producto.

Es responsabilidad del propietario asegurarse de que todos los usuarios de este producto conozcan plenamente todas las advertencias y precauciones.

- No lo use si está embarazada • Instálelo estrictamente de acuerdo con las instrucciones • Para garantizar la seguridad del usuario, verifique que todos los tornillos y otras piezas de conexión del dispositivo estén intactos antes de cada uso El ejercicio de intensidad incorrecta o excesiva no es bueno para la salud. Se recomienda consultar a un médico antes de realizar ejercicio. Es mejor usar ropa y calzado deportivo al hacer ejercicio. Si siente mareos, vómitos u otros síntomas adversos durante el ejercicio, debe detener el entrenamiento inmediatamente.
- Los niños y las personas discapacitadas solo pueden usarlo bajo la supervisión del personal correspondiente. • Tenga en cuenta que todos los tornillos y tuercas deben apretarse antes • No haga ejercicio media hora antes o después de las comidas o 1 hora antes de dormir
- Haga planes de ejercicios. • El peso del usuario no puede superar las 440 libras.

PRECAUCIÓN AL MONTAR

Antes de comenzar el montaje, lea atentamente la siguiente información e instrucciones:

- Se necesitan dos personas para el montaje. • Coloque todas las piezas en un área despejada y retire los materiales de embalaje. No deseche los materiales de embalaje hasta que se haya completado el montaje.
- Apriete todas las piezas a medida que las ensambla, a menos que se le indique lo contrario. de lo contrario.

- Al ensamblar el sistema de pesas, asegúrese de que todas las piezas estén orientadas como se muestra en los dibujos.

Las siguientes herramientas (no incluidas) son necesarias para el montaje: • Dos

llaves ajustables • Un mazo de goma

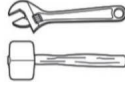

• Un destornillador estándar --- ---- (=■) • Un











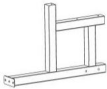



destornillador Phillips — • Lubricante,









como grasa o vaselina, y agua jabonosa.

El montaje será más cómodo si dispone de un juego de vasos, un juego de llaves de boca abierta o de boca cerrada o un juego de llaves de trinquete.

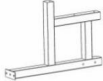
LISTA DE PIEZAS



1  1PCS	2  1PCS	3  2PCS	4  1PCS	5  2PCS
6  1PCS	7  1PCS	8  3PCS	9 M10X70  4PCS	10 M8X60  2PCS
11 M8X15  2PCS	12 M10  8PCS	13 M8  4PCS	14 M10  4PCS	

Paso 1

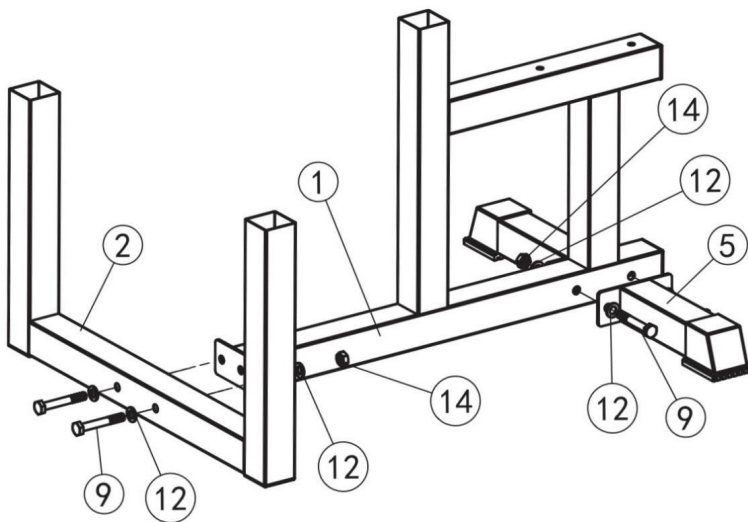
1  1PCS	2  1PCS	5  2PCS	4  1PCS	9 M10X70  4PCS
12 M10  8 PCS	14 M10  4PCS			





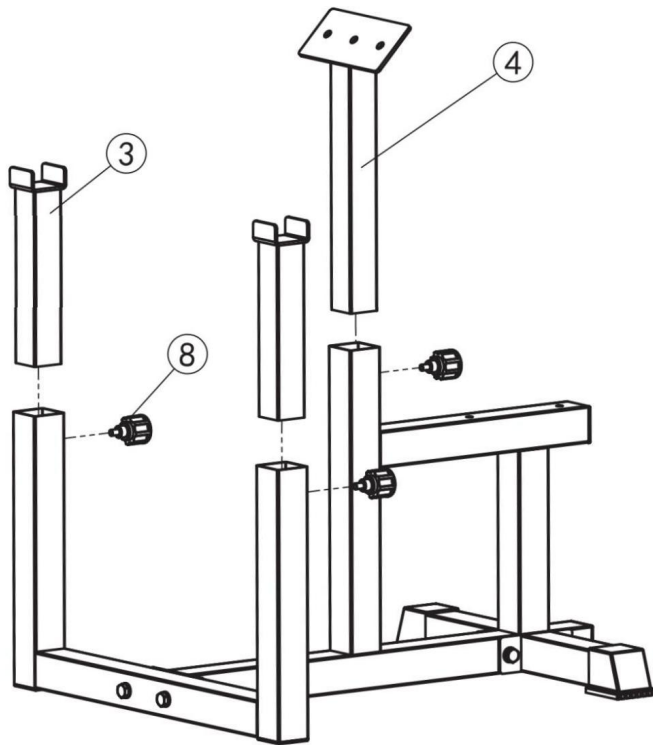

Paso 2

<p>3</p>  <p>2 piezas</p>	<p>4</p>  <p>Yo</p> <p>1 piezas</p>	<p>8</p>  <p>3 piezas</p>		
--	--	--	--	--



Paso 3

<p>6</p>  <p>1PCS</p>	<p>7</p>  <p>6PCS</p>	<p>10 M8X60</p>  <p>2PCS</p>	<p>11 M8X15</p>  <p>2PCS</p>	<p>13 M8</p>  <p>4PCS</p>
---	---	--	--	---

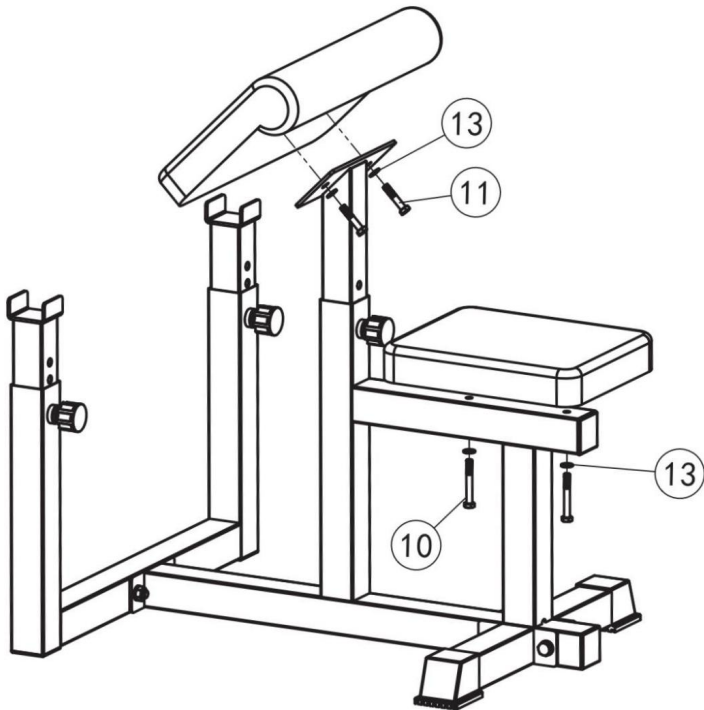

Fabricante: Shanghaimuxinmuyeyouxiangongsi Dirección:

Shuangchenglu 803nong11 hao1602A-1609shi, baoshanqu, shanghai 200000 CN.

Importado a AUS: SI HAO PTY LTD. 1 ROKEVA STREETEASTWOOD NSW2122 Australia

Importado a EE. UU.:

Sanven Technology Ltd. Suite 250, 9166 Anaheim Place, Rancho Cucamonga, CA91730

REPRESENTANTE DEL REINO UNIDO	
REPRESENTANTE CE	

YH CONSULTING LIMITED. A LA DIRECCIÓN DE YH
Consulting Limited Oficina 147, Centurion House, London
Road, Staines-upon-Thames, Surrey, TW18 4AX

E-CrossStu GmbH

Mainzer Landstr.69,
60329 Fráncfort del Meno.

Bezpieczeństwo działania

OSTRZEŻENIE:

Przed użyciem tego produktu należy przeczytać wszystkie instrukcje.

Właściciel jest odpowiedzialny za to, aby wszyscy użytkownicy tego produktu byli w pełni świadomi wszystkich ostrzeżeń i środków ostrożności.

• Nie używaj urządzenia, jeśli jesteś w ciąży. •

Zainstaluj urządzenie ściśle według instrukcji. • Aby zapewnić

bezpieczeństwo użytkownika, przed każdym użyciem sprawdź, czy wszystkie śruby i inne elementy łączące urządzenia są nienaruszone. Nieprawidłowe lub

• nadmierne ćwiczenia nie są dobre dla [zdrowia](#). Przed rozpoczęciem [ćwiczeń zaleca się konsultację z lekarzem](#). Podczas ćwiczeń najlepiej jest nosić

• odzież sportową i buty sportowe. Jeżeli podczas ćwiczeń odczuwasz zawroty

• głowy, wymioty lub inne niekorzystne objawy, powinieneś natychmiast przerwać trening.

• Dzieci i osoby niepełnosprawne mogą korzystać z urządzenia wyłącznie pod nadzorem odpowiedniego

personelu. • Należy pamiętać, że wszystkie śruby i nakrętki muszą być

dokręcone przed • Prosimy nie ćwiczyć na pół godziny przed/po posiłku lub 1 godzinę przed/po posiłku. przed snem •

Proszę zaplanować ćwiczenia. • Waga

użytkownika nie może przekraczać 440 funtów

MONTAŻ UWAGA

Przed rozpoczęciem montażu należy uważnie przeczytać poniższe informacje i instrukcje:

• Montaż wymaga dwóch osób. • Umieść

wszystkie części w wolnym miejscu i usuń materiały opakowaniowe. Nie wyrzucaj materiałów opakowaniowych, dopóki montaż nie zostanie ukończony.

• Dokręcaj wszystkie części podczas ich montażu, chyba że polecono inaczej.

W przeciwnym razie.

- Podczas montażu systemu ciężarkowego należy upewnić się, że wszystkie części są ustawione zgodnie z rysunkami.

Do montażu potrzebne są następujące narzędzia (nie dołączone): • Dwa klucze nastawne • Jeden gumowy młotek

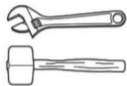











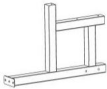



- Jeden standardowy śrubokręt --- ----- (=) • Jeden śrubokręt krzyżakowy —









smarujący, taki jak smar stały lub wazelina, oraz woda z mydłem.

Montaż będzie wygodniejszy, jeśli posiadasz zestaw nasadek, zestaw kluczy płaskich lub oczkowych, albo zestaw kluczy grzechotkowych.

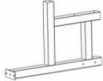
LISTA CZĘŚCI



1  1PCS	2  1PCS	3  2PCS	4  1PCS	5  2PCS
6  1PCS	7  1PCS	8  3PCS	9 M10X70  4PCS	10 M8X60  2PCS
11 M8X15  2PCS	12 M10  8PCS	13 M8  4PCS	14 M10  4PCS	

Krok 1

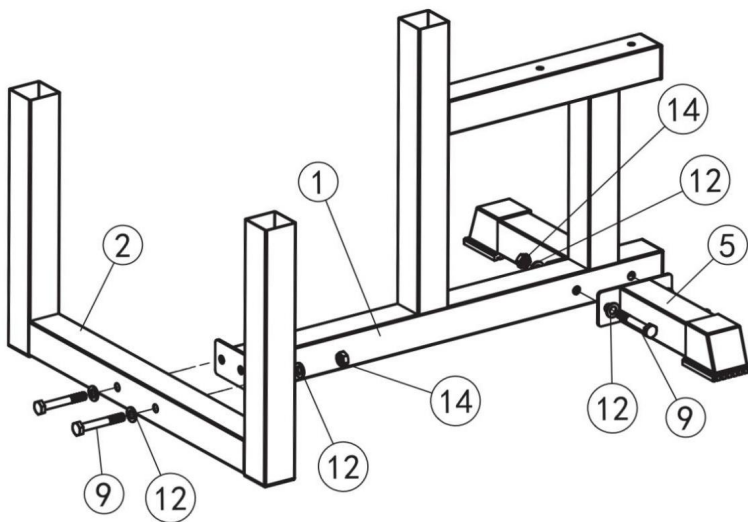
1  1PCS	2  1PCS	5  2PCS	4  1PCS	9 M10X70  4PCS
12 M10  8 PCS	14 M10  4PCS			





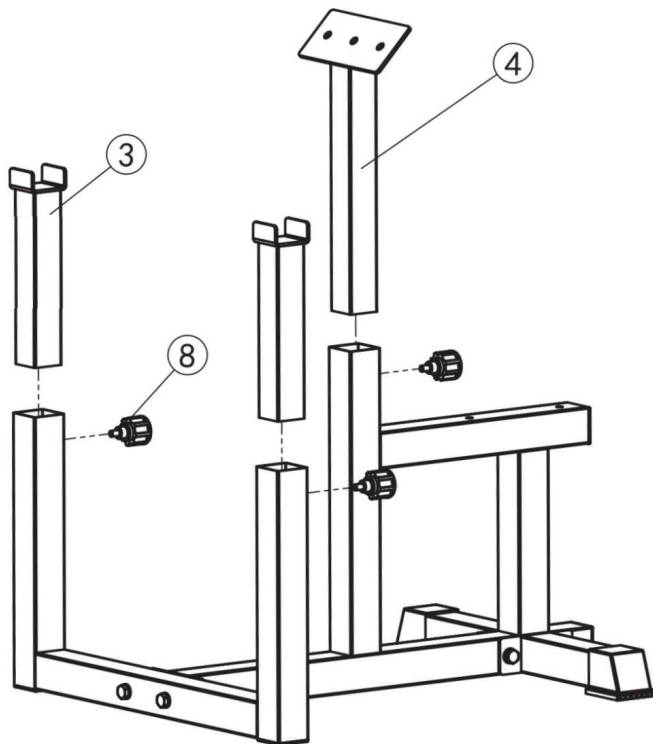

Krok 2

<p>3</p>  <p>2 SZT.</p>	<p>4</p>  <p>1 SZT.</p>	<p>8</p>  <p>3 SZT.</p>		
--	--	--	--	--



Krok 3

6  1PCS	7  6PCS	10 M8X60  2PCS	11 M8X15  2PCS	13 M8  4PCS
---	---	--	--	---

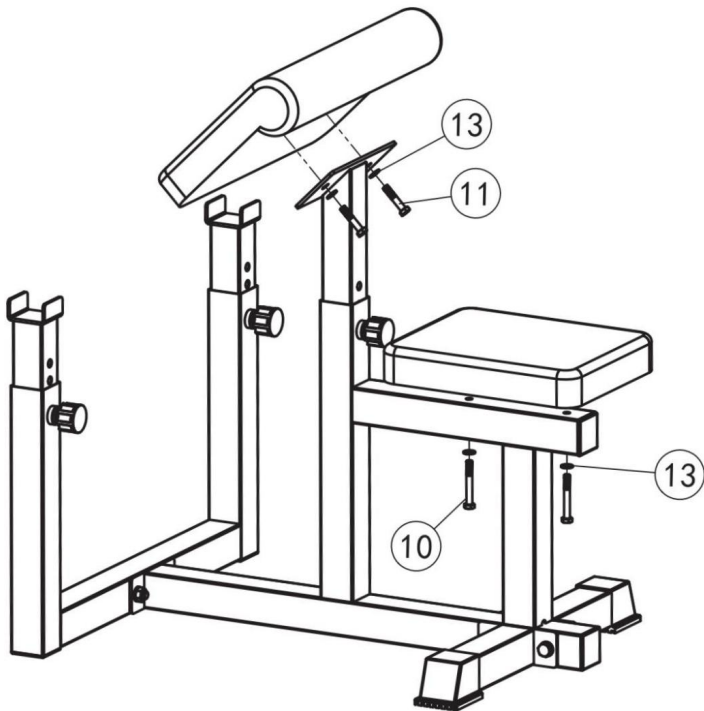

Producent: Shanghaimuxinmuyeyouxiangongsi Adres:

Shuangchenglu 803nong11 hao1602A-1609shi, baoshanqu, szanghaj 200000 CN.

Importowane do AUS: SI HAO PTY LTD. 1 ROKEVA STREETEASTWOOD NSW2122 Australia

Importowane do USA:

Sanven Technology Ltd. Suite 250, 9166 Anaheim Place, Rancho Cucamonga, CA91730

REP WIELKIEJ BRYTANII	
Przedstawiciel UE	

YH CONSULTING LIMITED. C/O YH Consulting Limited Biuro
147, Centurion House, London Road, Staines-upon-
Thames, Surrey, TW18 4AX

E-CrossStu GmbH
Mainzer Landstr.69,
60329 Frankfurt nad Menem.

Bedrijfsveiligheid

WAARSCHUWING:

Lees alle instructies voordat u dit product gebruikt

Het is de verantwoordelijkheid van de eigenaar om ervoor te zorgen dat alle gebruikers van dit product volledig op de hoogte zijn van alle waarschuwingen en voorzorgsmaatregelen.

- Gebruik het niet als u zwanger bent •

Installeer het apparaat strikt volgens de instructies • Controleer voor

elk gebruik of alle schroeven en andere verbindingsonderdelen op het apparaat intact zijn

om de veiligheid van de gebruiker te garanderen. Onjuiste of overmatige

- intensiteitsoefeningen zijn niet goed voor [de gezondheid](#). Het is raadzaam om voor het sporten een arts te raadplegen. Het is het beste om
- sportkleding en sportschoenen te dragen tijdens het sporten. Als u tijdens het
- sporten last krijgt van duizeligheid, braken of andere nadelige symptomen, dient u onmiddellijk te stoppen met trainen.

- Kinderen en gehandicapten mogen het alleen gebruiken onder toezicht van bevoegd personeel. • Let op dat

alle schroeven en moeren goed vastgedraaid moeten zijn. • Sport niet een half uur voor/na de maaltijd of 1 uur na de maaltijd.

voor het

slapengaan • Maak een oefenplan. • Het

gewicht van de gebruiker mag niet meer dan 440 lbs bedragen.

MONTAGE LET OP

Lees de volgende informatie en instructies zorgvuldig door voordat u met de montage begint:

- Voor de montage zijn twee personen nodig.
- Plaats alle onderdelen in een open ruimte en verwijder het verpakkingsmateriaal. Gooi het verpakkingsmateriaal pas weg als de montage is voltooid.
- Draai alle onderdelen vast terwijl u ze monteert, tenzij anders aangegeven anders.

- Zorg ervoor dat alle onderdelen in de juiste positie staan zoals aangegeven in de tekeningen wanneer u het gewichtssysteem in elkaar zet.

Voor de montage zijn de volgende gereedschappen (niet inbegrepen) nodig:

- Twee verstelbare sleutels
- Een rubberen hamer

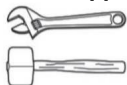











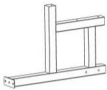



- Één standaard schroevendraaier --- ----- (=ÿ) • Één kruiskopschroevendraaier — •









Smeermiddel, zoals vet of vaseline, en zeepsop.

De montage is eenvoudiger als u een doppenet, een set steek- of sluitsleutels of een set ratelsleutels bij de hand hebt.

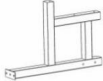
ONDERDELENLIJST



1  1PCS	2  1PCS	3  2PCS	4  1PCS	5  2PCS
6  1PCS	7  1PCS	8  3PCS	9 M10X70  4PCS	10 M8X60  2PCS
11 M8X15  2PCS	12 M10  8PCS	13 M8  4PCS	14 M10  4PCS	

Step 1

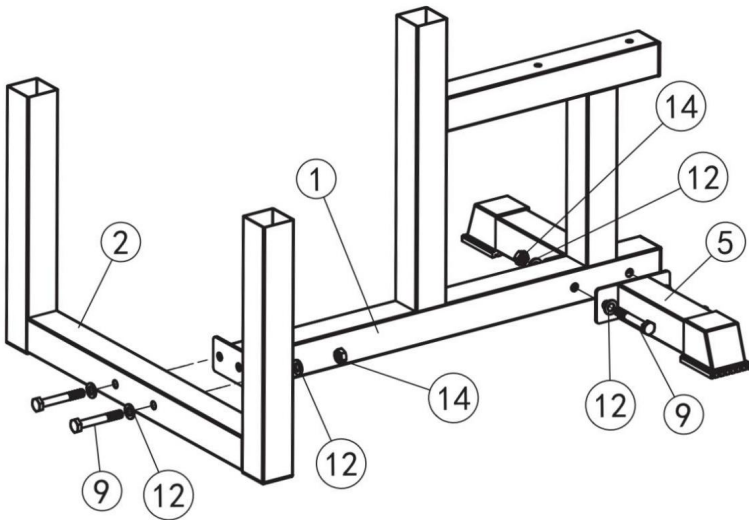
1  1PCS	2  1PCS	5  2PCS	4  1PCS	9 M10X70  4PCS
12 M10  8 PCS	14 M10  4PCS			





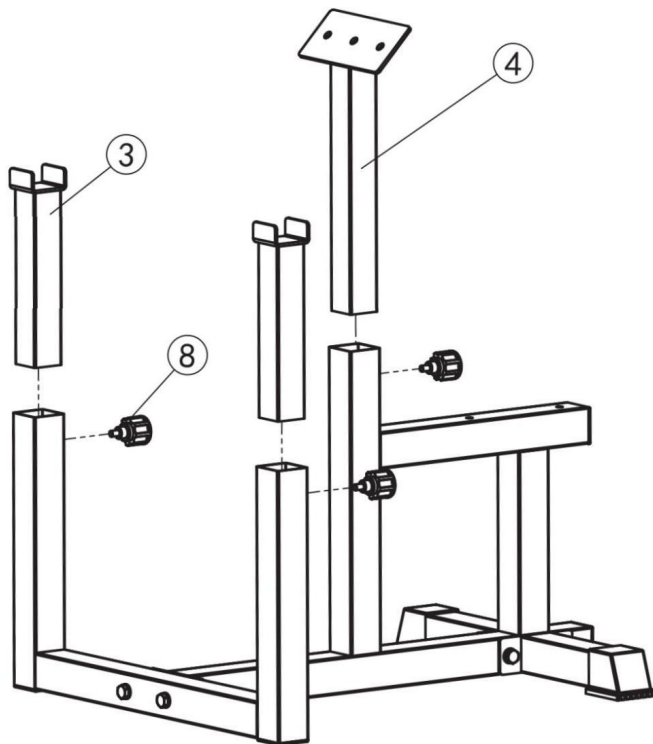

Stap 2

<p>3</p>  <p>2 STUKS</p>	<p>4</p>  <p>1 STUKS</p>	<p>8</p>  <p>3 STUKS</p>		
---	---	---	--	--



Step 3

6  1PCS	7  6PCS	10 M8X60  2PCS	11 M8X15  2PCS	13 M8  4PCS
---	---	--	--	---

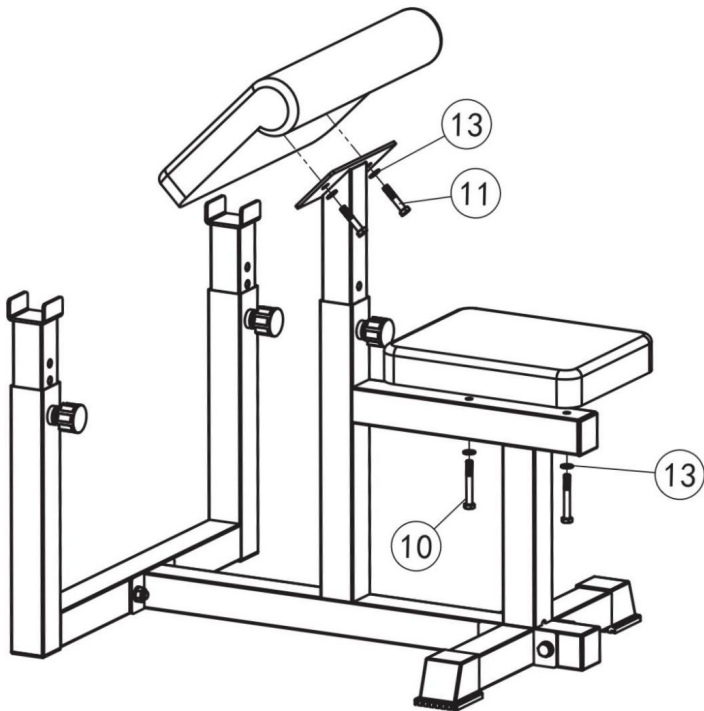

Fabrikant: Shanghaimuxinmuyeyouxiangongsi **Adres:**

Shuangchenglu 803nong11 hao1602A-1609shi, baoshanqu, shanghai 200000 CN.

Geïmporteerd naar AUS: SI HAO PTY LTD. 1 ROKEVA STREETEASTWOOD NSW2122
Australië **Geïmporteerd**

naar de VS: Sanven Technology Ltd. Suite 250, 9166 Anaheim Place, Rancho
Cucamonga, CA91730

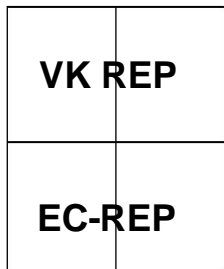

YH CONSULTING LIMITED. C/O YH Consulting Limited
Kantoor 147, Centurion House, London Road, Staines-
upon-Thames, Surrey, TW18 4AX

E-CrossStu GmbH

Mainzer Landstr.69,
60329 Frankfurt am Main.

Driftsäkerhet

VARNING:

Läs alla instruktioner innan du använder denna produkt

Det är ägarens ansvar att se till att alla användare av denna produkt är fullt medvetna om alla varningar och försiktighetsåtgärder.

- Använd den inte om du är gravid • Installera strikt enligt instruktionerna • För att garantera användarsäkerheten, kontrollera om alla skruvar och andra anslutningsdelar på enheten är intakta före varje användning. Felaktig eller överdriven träning är inte bra för [hälsan](#) .It
 - rekommenderas att konsultera en läkare innan du tränar. Det är bäst att bära sportkläder och sportskor när du tränar. Om du känner yrsel,
 - kräkningar eller andra negativa symtom under träning bör du avbryta träningen
 - omedelbart.
- Barn och funktionshindrade får endast använda den under överinseende av relevant personal.
- Observera att alla skruvar och muttrar måste dras åt innan • Träna inte en halvtimme före/efter måltid eller 1 timme före sömn • Gör träningsplaner. • Användarens vikt får inte överstiga 440lbs

MONTERING FÖRSIKTIGT

Innan du påbörjar monteringen, läs noggrant följande information och instruktioner:

- Montering kräver två personer. • Placera alla delar i ett fritt utrymme och ta bort förpackningsmaterialet. Kassera inte förpackningsmaterialet förrän monteringen är klar.
- Dra åt alla delar när du monterar dem, om du inte uppmanas att göra det annat.

- När du monterar viktsystemet, se till att alla delar är orienterade som visas på ritningarna.

Följande verktyg (ingår ej) krävs för montering: • Två justerbara skiftnycklar • En gummiklubba

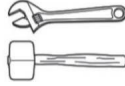









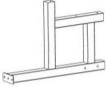





- En standardskruvmejsel --- ----- (=) • En stjärnskruvmejsel — • Smörjmedel, som fett eller vaselin, och tvålatten.







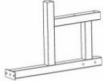

Monteringen blir bekvämare om du har en hylssats, en uppsättning med öppna eller slutna skiftnycklar eller en uppsättning spärrnycklar.

DELLISTA



1  1PCS	2  1PCS	3  2PCS	4  1PCS	5  2PCS
6  1PCS	7  1PCS	8  3PCS	9 M10X70  4PCS	10 M8X60  2PCS
11 M8X15  2PCS	12 M10  8PCS	13 M8  4PCS	14 M10  4PCS	

Step 1

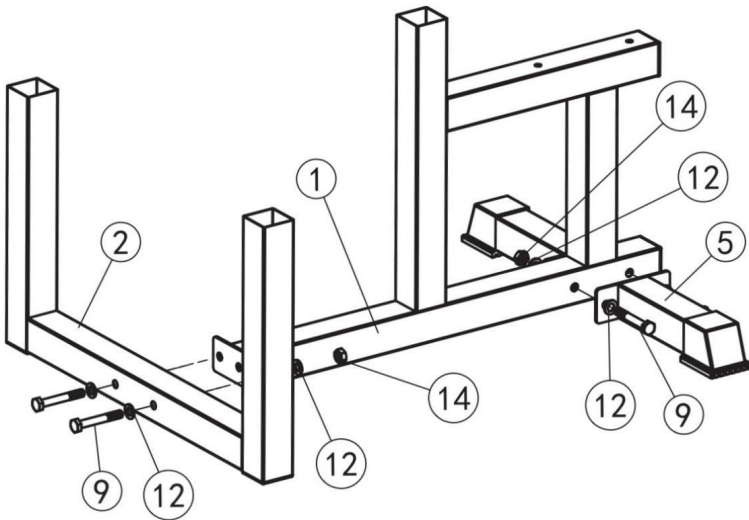
1  1PCS	2  1PCS	5  2PCS	4  1PCS	9 M10X70  4PCS
12 M10  8 PCS	14 M10  4PCS			





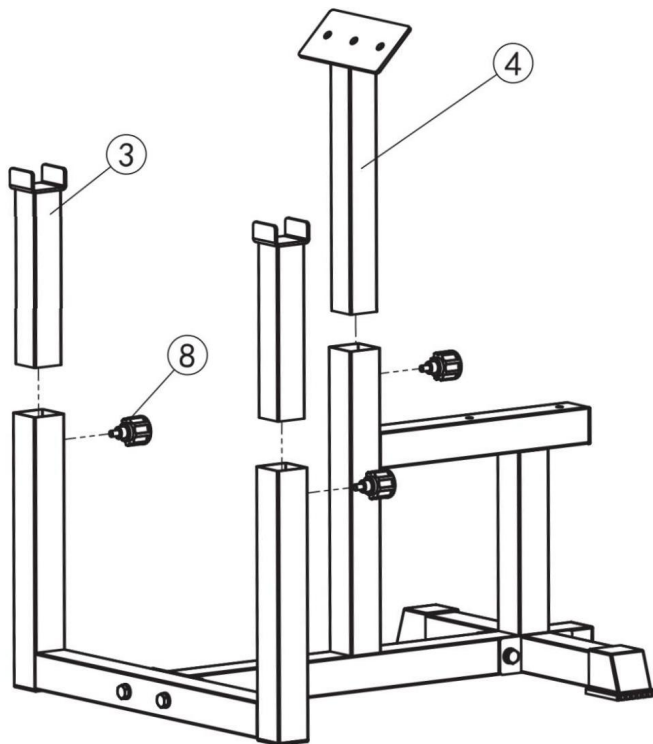

Step 2

<p>3</p>  <p>2 st</p>	<p>4</p>  <p>J</p> <p>1 st</p>	<p>8</p>  <p>3 st</p>		
--	---	--	--	--



Step 3

6  1PCS	7  6PCS	10 M8X60  2PCS	11 M8X15  2PCS	13 M8  4PCS
---	---	--	--	---

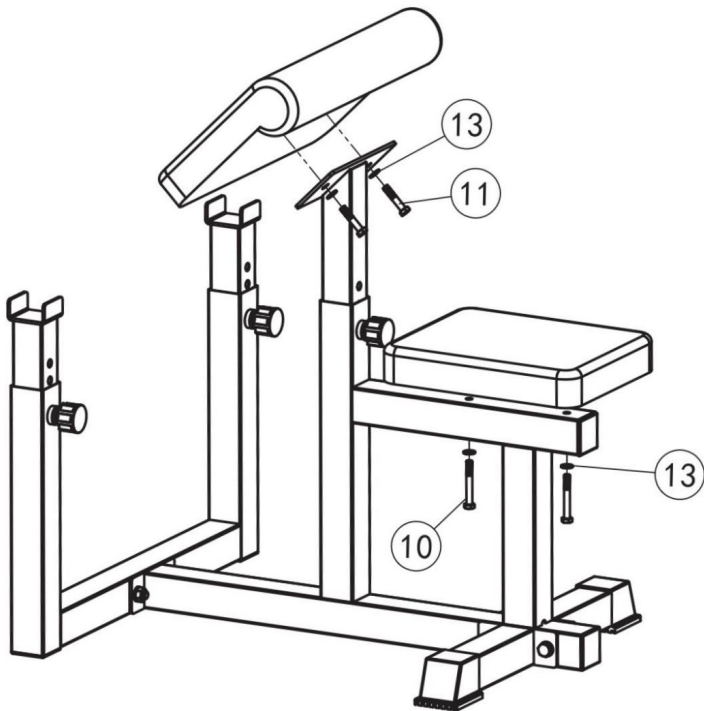

Tillverkare: Shanghaimuxinmuyeyouxiangongsi **Adress:**

Shuangchenglu 803nong11 hao1602A-1609shi, baoshanqu, shanghai 200000 CN.

Importerad till AUS: SI HAO PTY LTD. 1 ROKEVA STREETEASTWOOD NSW2122
Australien **Importerad**

till USA: Sanven Technology Ltd. Suite 250, 9166 Anaheim Place, Rancho Cucamonga,
CA91730

UK REP	
EC REP	

YH CONSULTING LIMITED. C/O YH Consulting Limited
Office 147, Centurion House, London Road, Staines-
upon-Thames, Surrey, TW18 4AX

E-CrossStu GmbH
Mainzer Landstr.69,
60329 Frankfurt am Main.