

# VEVOR

**Affordable. Reliable. Home Improvement.**



## **KIDS STORAGE BENCHES**

**MODEL: C250224D-01**

# VEVOR



Affordable. Reliable. Home Improvement.

## KIDS STORAGE BENCHES

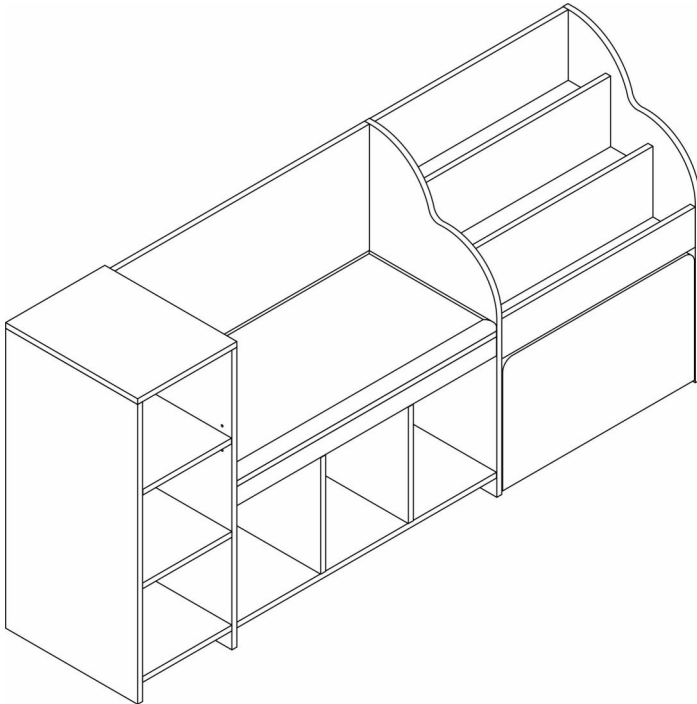
**MODEL: C250224D-01**



This is the original instruction, please read all manual instructions carefully before operating. VEVOR reserves a clear interpretation of our user manual. The appearance of the product shall be subject to the product you received. Please forgive us that we won't inform you again if there are any technology or software updates on our product.

	<p>Warning-To reduce the risk of injury, user must read instructions manual carefully.</p> <p><b>Note: Adult assembly required !</b></p>
	<p>Compliance is a CE security certification.</p>
<p><b>Ages</b></p>	<p>3 Years +</p>

**SAFETY INSTRUCTIONS**

**WARNING:**

**Read this material before using this product. Failure to do so may result in serious injury.**

**Assembly precautions**

1. Assemble only according to these instructions. Improper assembly may create hazards.
2. Keep the assembly area clean and well-lit.
3. The product capabilities apply to properly and completely assembled products only.
4. Assemble on a flat, level, hard and smooth surface capable of safely supporting the Kids Storage Benches.
5. For additional information regarding the parts listed in the following pages, please refer to the Assembly Diagram of this manual. Unwrap and separate all parts in a clean work area.

**Use precautions**

1. DO NOT SIT OR STAND ON THIS ITEM.
2. This product is not a toy. Do not allow children to play with or near this item.
3. Do not exceed specified weight capacities.
4. Use only on a flat, level, hard, and smooth surface that can safely support a fully loaded Kids Storage Benches.
5. Use as intended only.
6. Inspect before every use; do not use if parts are loose or damaged.

**SAVE THIS MANUAL**

## INSTALLATION OF CAMS AND PINS

Screw the pin into the hole. To set the cams correctly, ensure that the arrow on the cam is opening to the hole of the pin it is locking. Lock the cam by turning the cam head with a screwdriver until it is tightened. Please do not use an electric screwdriver to assemble the unit.

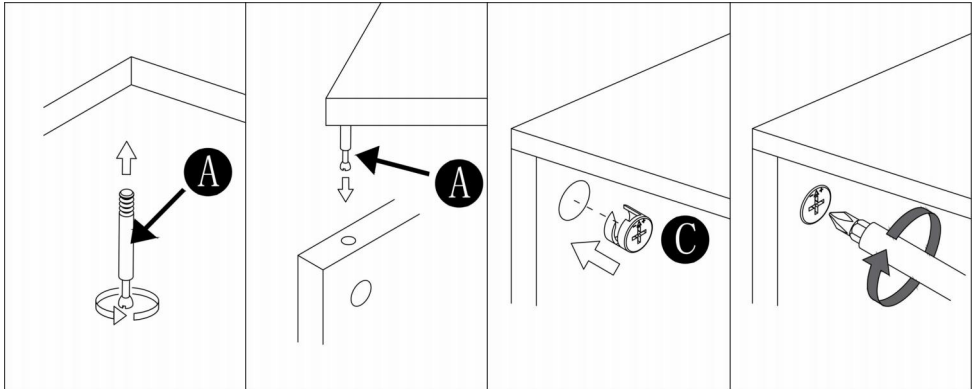



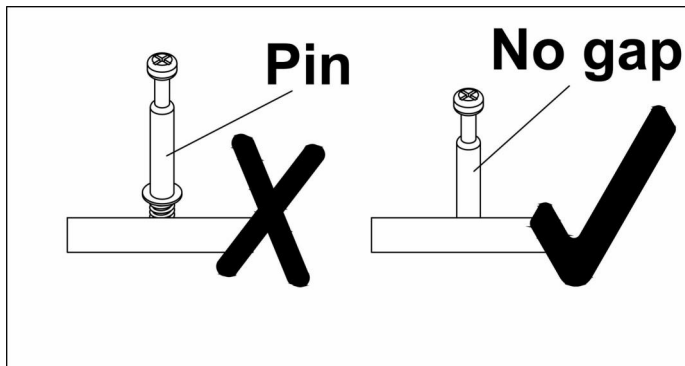



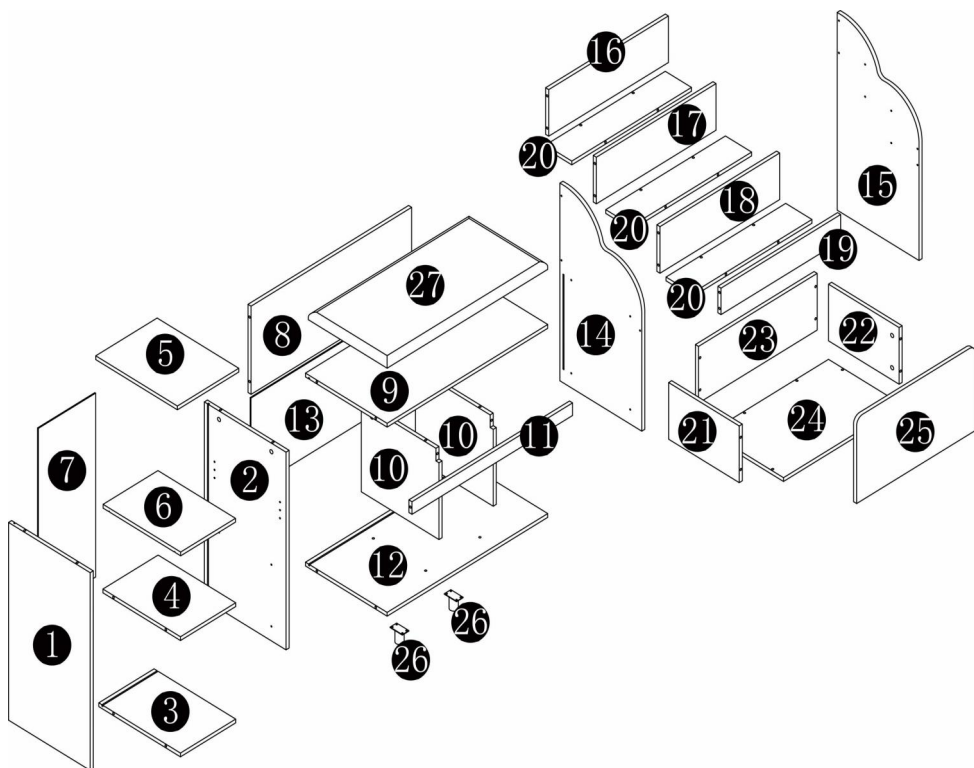

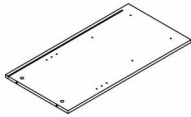
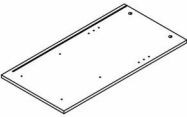

Read each step carefully before starting. It is very important that each step of instruction is performed in the correct order. If these steps are not followed in sequence, assembly difficulties will occur.



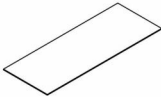

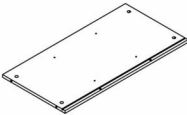

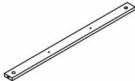
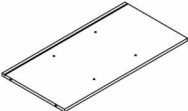
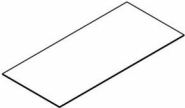
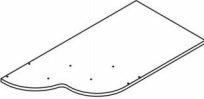
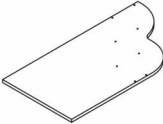
## PARTS & HARDWARE LIST

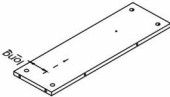
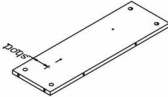
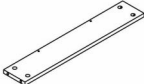
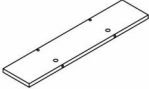

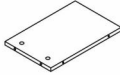
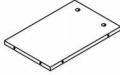

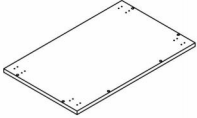

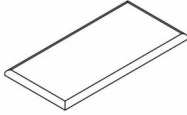





# Hardware List

 <b>1</b> 1pc	 <b>2</b> 1pc	 <b>3</b> 1pc	 <b>4</b> 1pc
 <b>5</b> 1pc	 <b>6</b> 1pc	 <b>7</b> 1pc	 <b>8</b> 1pc
 <b>9</b> 1pc	 <b>10</b> 2pcs	 <b>11</b> 1pc	 <b>12</b> 1pc
 <b>13</b> 1pc	 <b>14</b> 1pc	 <b>15</b> 1pc	 <b>16</b> 1pc
 <b>17</b> 1pc	 <b>18</b> 1pc	 <b>19</b> 1pc	 <b>20</b> 3pcs

 <b>21</b> 1pc	 <b>22</b> 1pc	 <b>23</b> 1pc	 <b>24</b> 1pc
 <b>25</b> 1pc	 <b>26</b> 2pcs	 <b>27</b> 1pc	

## Parts List

 <b>A</b> 58pcs	 <b>B</b> 22pcs M7X50MM	 <b>C</b> 58pcs	 <b>P</b> 36pcs M3.5X12MM	 <b>Q</b> 4pcs
 <b>U</b> 12pcs	 <b>Y</b> 4pcs 1.5"	 <b>Z</b> 58pcs φ20		

## ASSEMBLY STEP

1

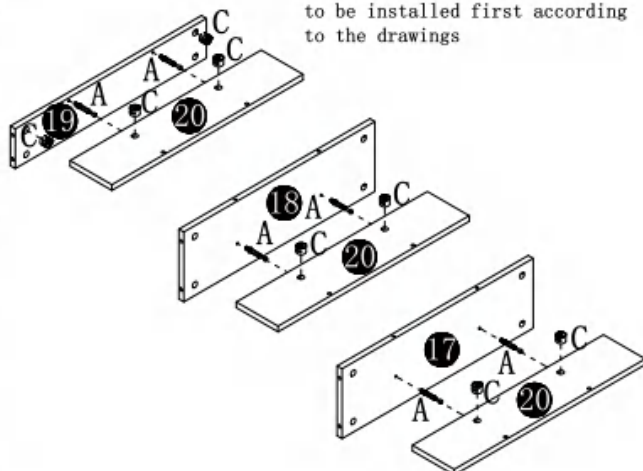
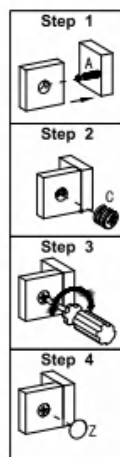

Please note that for Board 19, two accessories numbered C need to be installed first according to the drawings

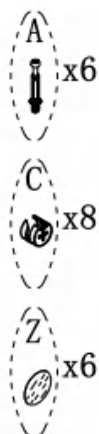

2

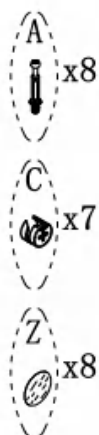
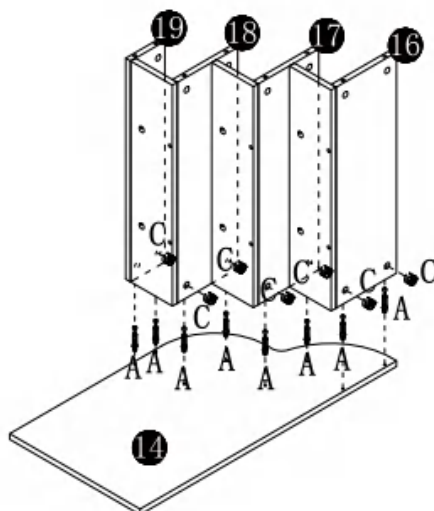
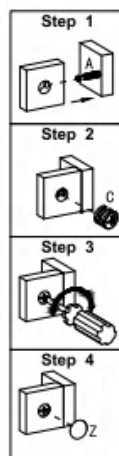

3

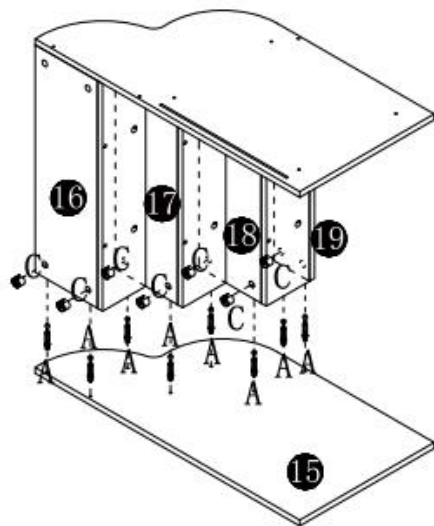
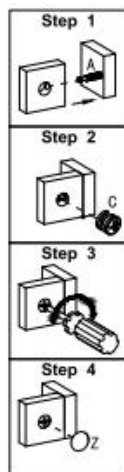

4

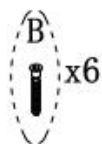
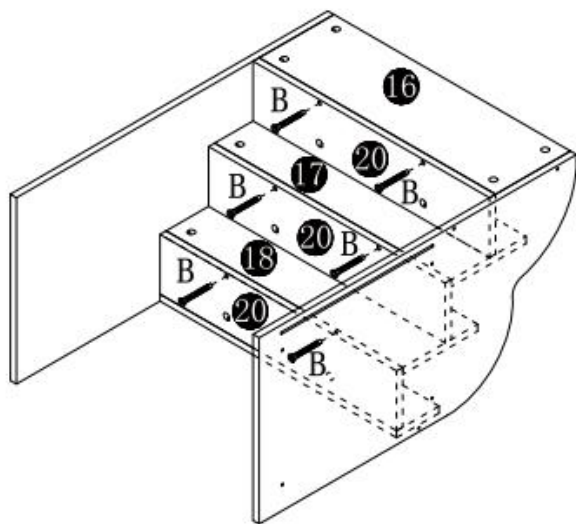

5

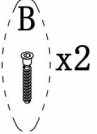
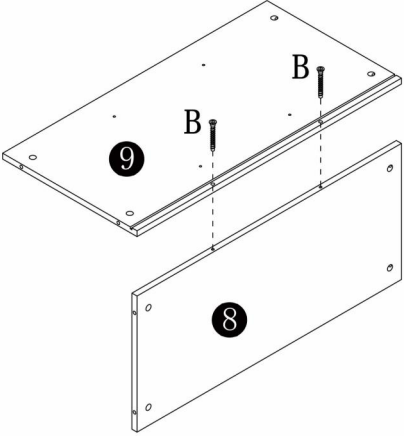

6

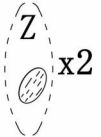
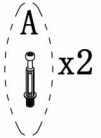
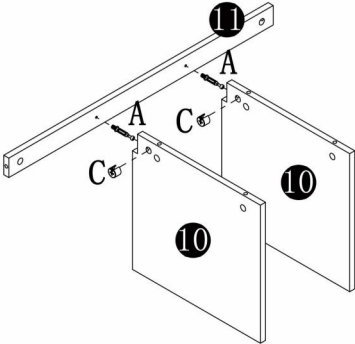
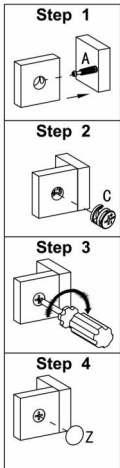

7

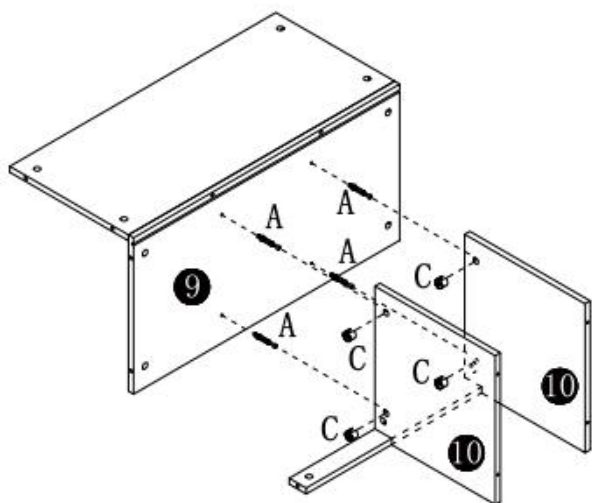
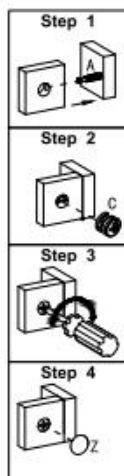

8

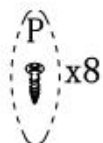
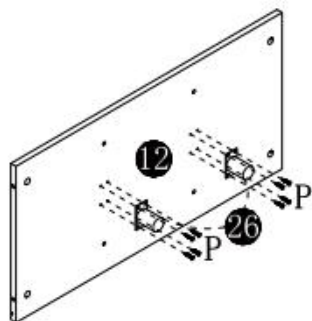

9

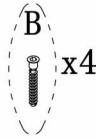
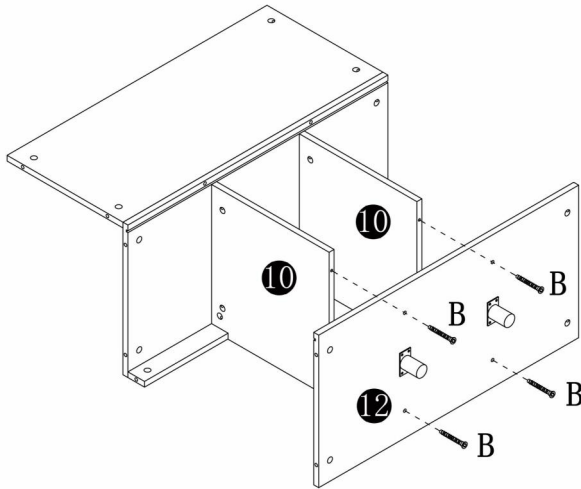

10

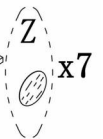
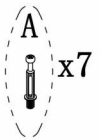
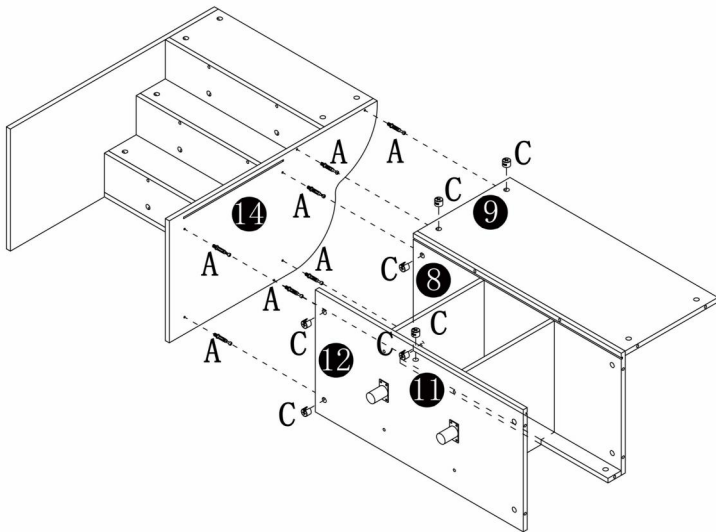
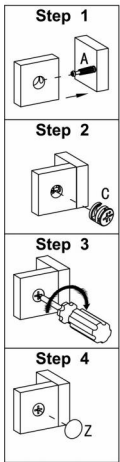

11

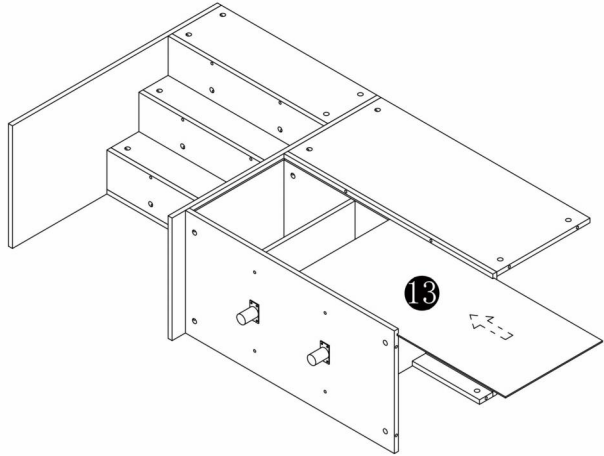

12

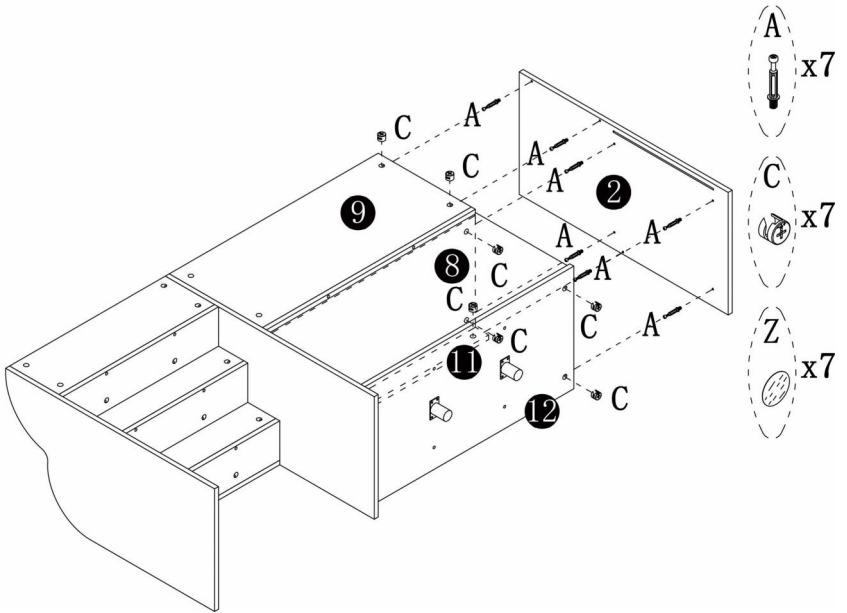
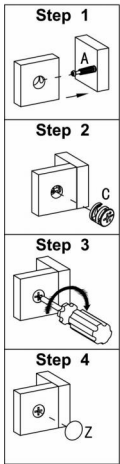

13

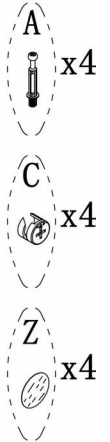
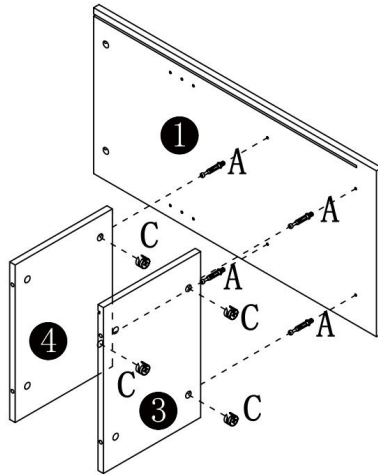
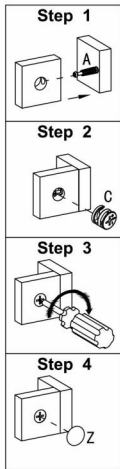

14

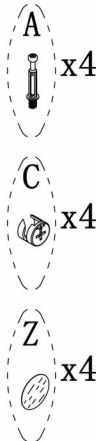
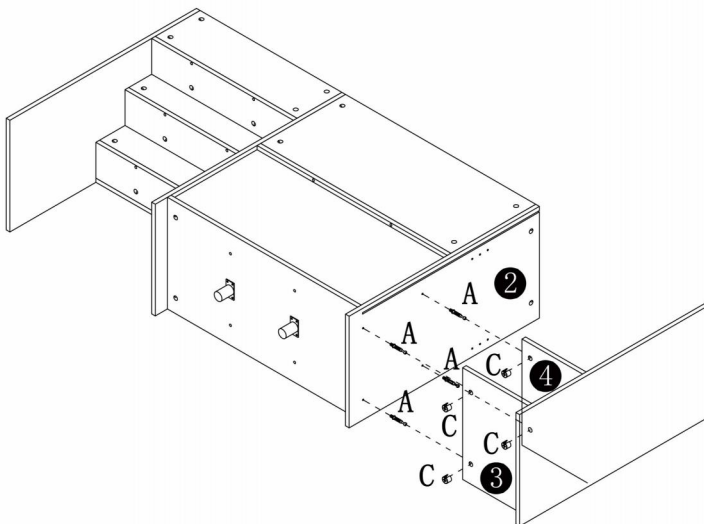
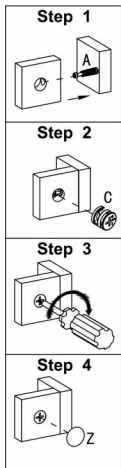

15

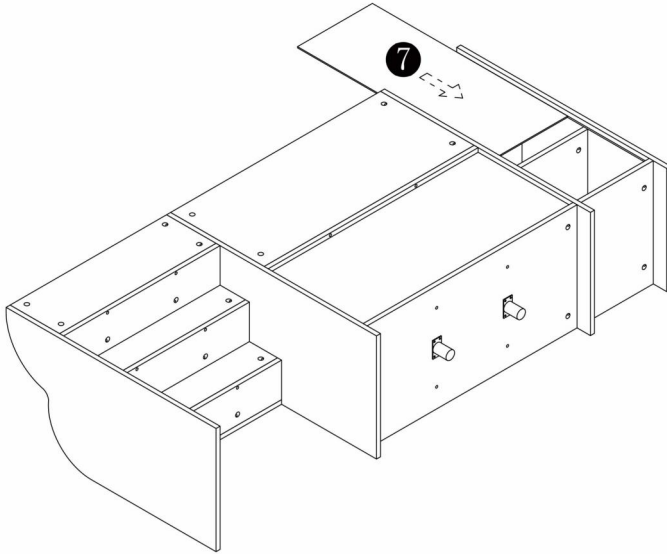

16

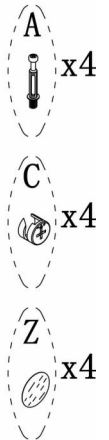
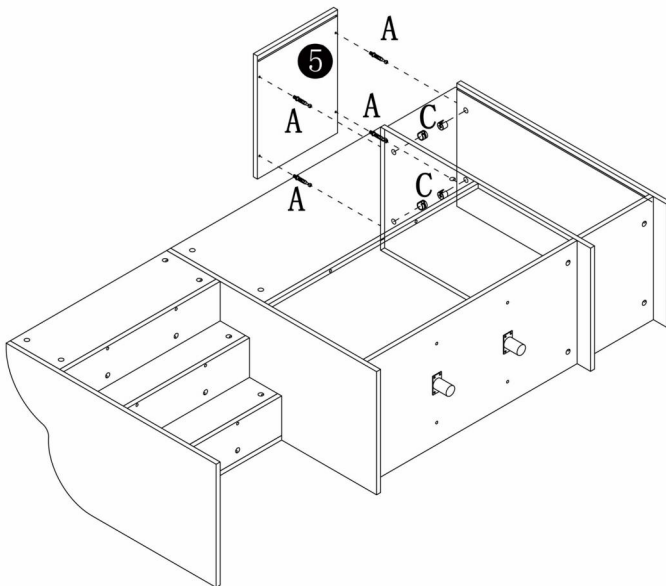
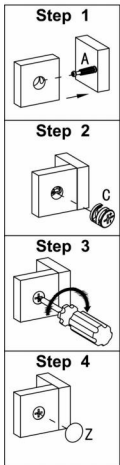

17

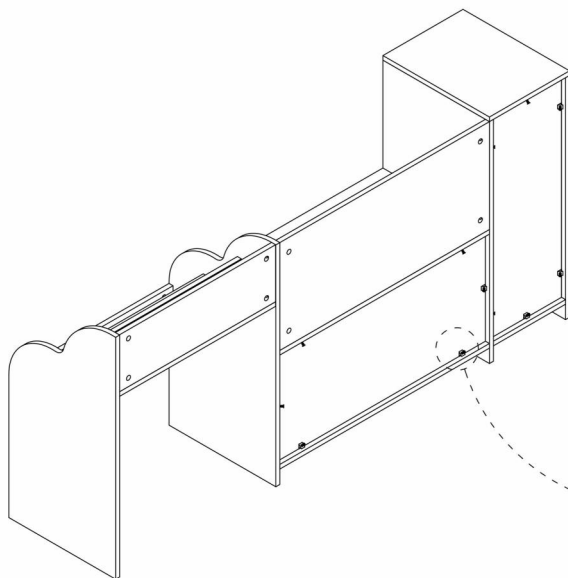

U  
x12

P  
x12

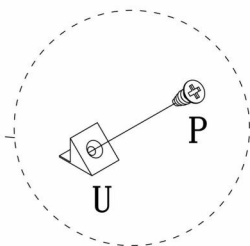

18

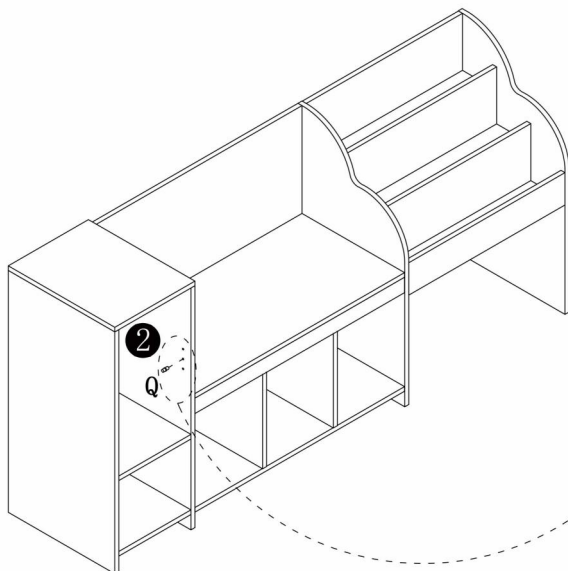

Q  
x4

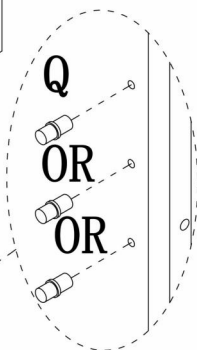

19

The movable shelf can be placed in three positions.

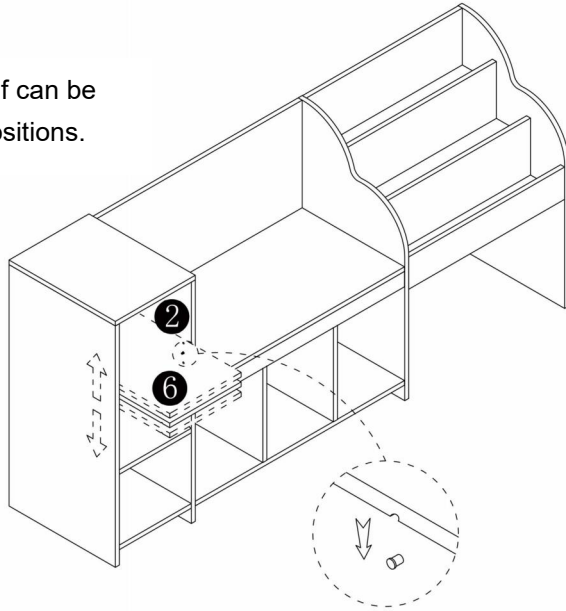

20

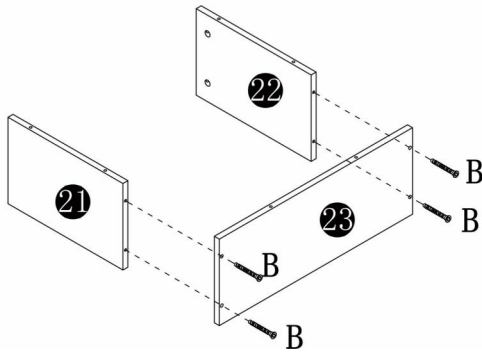
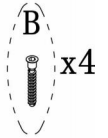

# 21

Directional wheels can only move forward and backward, while non-universal wheels cannot rotate 360 degrees.

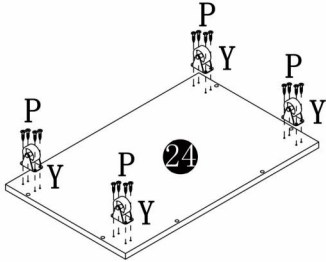
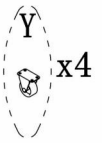
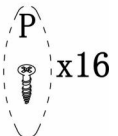

# 22

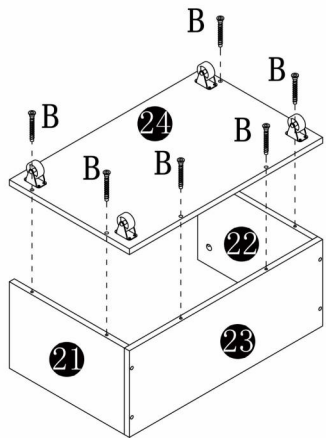
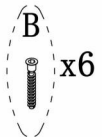

23

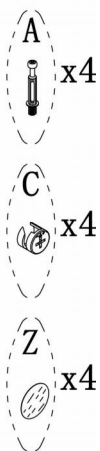
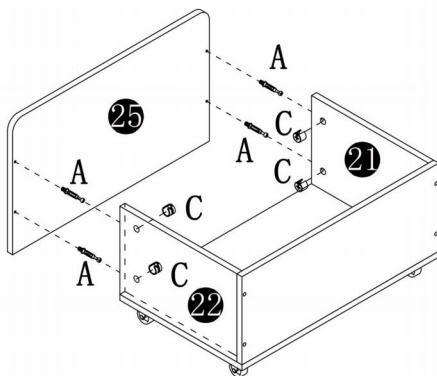
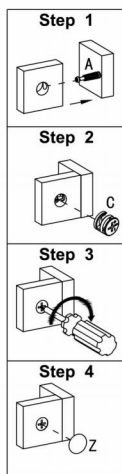

24

The seat cushion is zipped and detachable for cleaning.

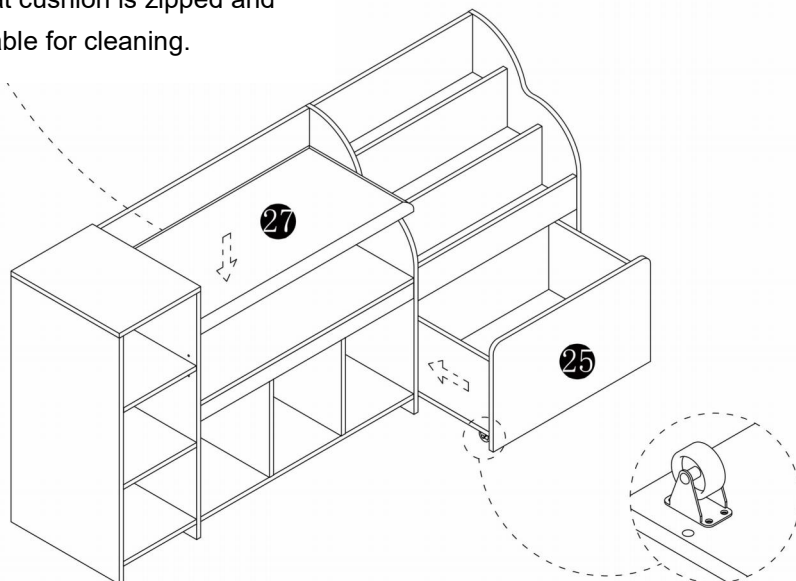

## PRODUCT PARAMETER

<b>Model</b>	C250224D-01
<b>Static Load-Bearing</b>	MAX 350lbs
<b>Colour</b>	White
<b>Product Size</b>	1700×400×800mm

**Manufacturer:** Guangzhou Dingxin Office Furniture Co., LTD

**Manufacturer Address:** No. 1700, Renhe Road, Aotou Town, Conghua District, Guangzhou, Guangdong Province

**Imported to AUS:** SIHAO PTY LTD. 1 ROKEVA STREET EASTWOOD NSW 2122 Australia

**Imported to USA:** Sanven Technology Ltd. Suite 250, 9166 Anaheim Place, Rancho Cucamonga, CA 91730

<b>UK</b>	<b>REP</b>
-----------	------------

YH CONSULTING LIMITED. C/O YH Consulting Limited Office 147, Centurion House, London Road, Staines-upon-Thames, Surrey, TW18 4AX

<b>EC</b>	<b>REP</b>
-----------	------------

E-CrossStu GmbH  
Mainzer Landstr.69,  
60329 Frankfurt am Main.



# VEVOR

**Affordable. Reliable. Home Improvement.**



BANCS DE RANGEMENT POUR ENFANTS

MODÈLE : C250224D-01

# VEVOR

Affordable. Reliable. Home Improvement.



RANGEMENT POUR ENFANTS

## BANCS

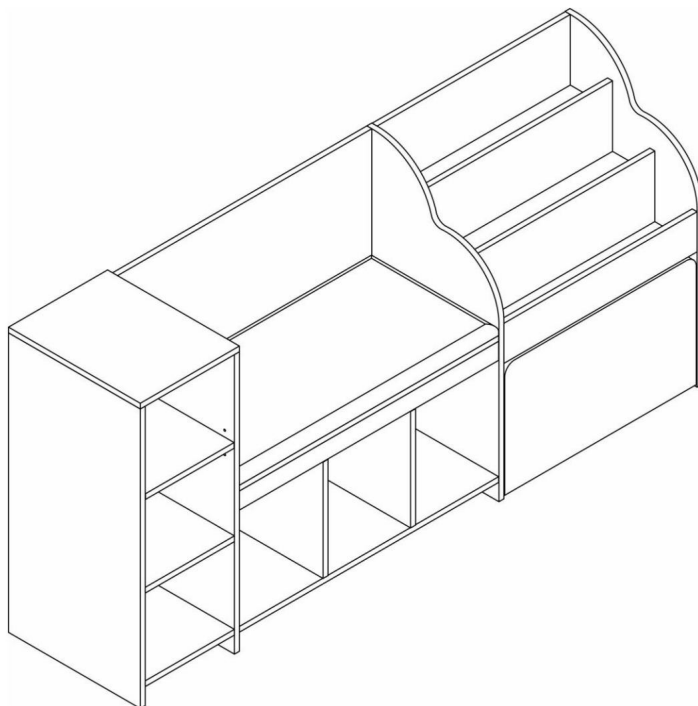
MODÈLE : C250224D-01



Ceci est le mode d'emploi d'origine. Veuillez lire attentivement l'intégralité du manuel avant utilisation. VEVOR se réserve le droit d'interpréter clairement ce manuel d'utilisation. L'apparence du produit dépend du produit que vous avez reçu. Veuillez nous excuser de ne pas vous informer ultérieurement des mises à jour technologiques ou logicielles de notre produit.

	<p>Avertissement - Pour réduire le risque de blessure, l'utilisateur doit lire Lisez attentivement le manuel d'instructions. Remarque : assemblage par un adulte requis !</p>
	<p>La conformité est une certification de sécurité CE.</p>
<p>Âge</p>	<p>3 ans et plus</p>

## CONSIGNES DE SÉCURITÉ

### AVERTISSEMENT:

Lire ce document avant d'utiliser ce produit. Le non-respect de cette consigne peut entraîner des blessures graves.

### Précautions de montage

1. Assembler uniquement selon ces instructions. Un assemblage incorrect peut créer des dangers.
2. Gardez la zone de montage propre et bien éclairée.
3. Les capacités du produit s'appliquent aux produits correctement et complètement assemblés. produits uniquement.
4. Assemblez sur une surface plane, de niveau, dure et lisse capable de supporter en toute sécurité soutenir les bancs de rangement pour enfants.
5. Pour plus d'informations sur les pièces répertoriées ci-dessous pages, veuillez vous référer au schéma d'assemblage de ce manuel. Déballer et séparer toutes les pièces dans une zone de travail propre.

### Précautions d'emploi

1. NE PAS S'ASSEOIR NI SE TENIR DEBOUT SUR CET ARTICLE.
2. Ce produit n'est pas un jouet. Ne laissez pas les enfants jouer avec ou à proximité. article.
3. Ne pas dépasser les capacités de poids spécifiées.
4. Utiliser uniquement sur une surface plane, nivelée, dure et lisse qui peut être utilisée en toute sécurité soutenir un banc de rangement pour enfants entièrement chargé.
5. Utiliser uniquement comme prévu.
6. Inspectez avant chaque utilisation ; ne pas utiliser si des pièces sont desserrées ou endommagées.

CONSERVEZ CE MANUEL

## INSTALLATION DE CAMES ET DE GOUPILLES

Vissez la goupille dans le trou. Pour régler correctement les cames, assurez-vous que la flèche de la came s'ouvre vers le trou de la goupille qu'elle verrouille. Verrouillez la came en tournant la tête de came avec un tournevis jusqu'à ce qu'elle soit serrée. Veuillez ne pas utiliser d'outil électrique. tournevis pour assembler l'ensemble.

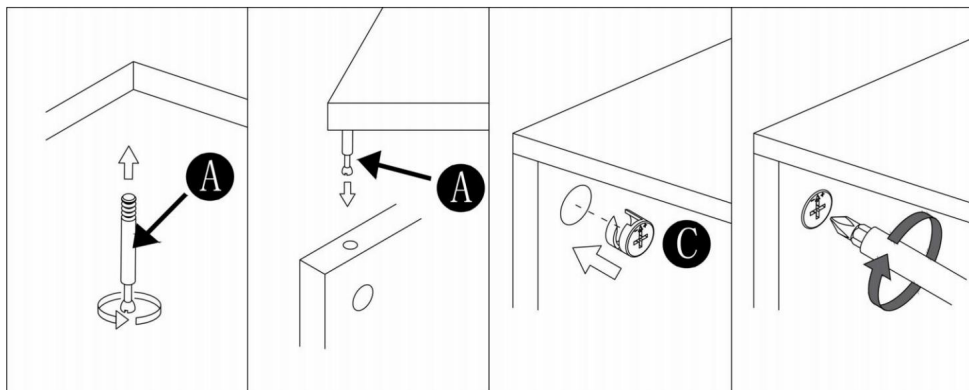



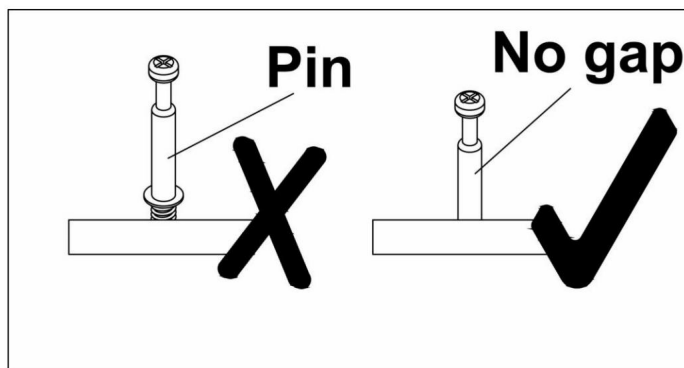



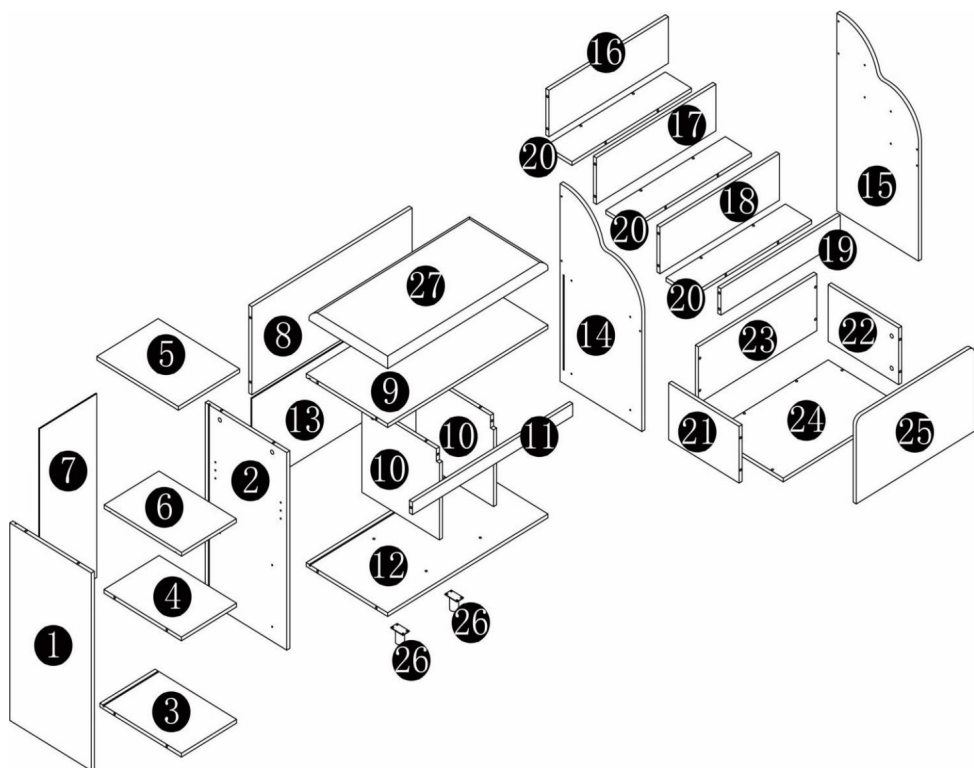



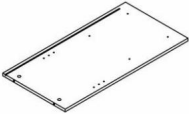
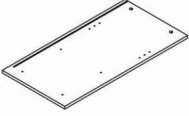

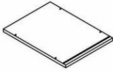

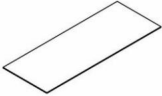
Lisez attentivement chaque étape avant de commencer. Il est essentiel de suivre chaque étape des instructions dans le bon ordre. Si ces étapes ne sont pas suivies dans l'ordre, des difficultés d'assemblage surviendront.

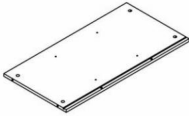

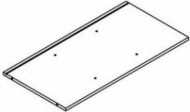
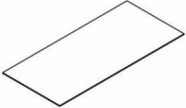

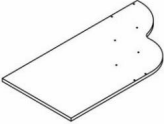

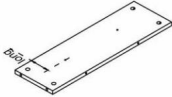
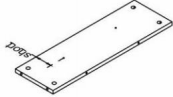

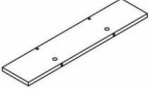
LISTE DES PIÈCES ET DU MATÉRIEL







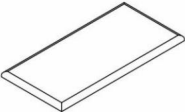





# Liste du matériel

 <p><b>1</b> 1pc</p>	 <p><b>2</b> 1pc</p>	 <p><b>3</b> 1pc</p>	 <p><b>4</b> 1pc</p>
 <p><b>5</b> 1pc</p>	 <p><b>6</b> 1pc</p>	 <p><b>7</b> 1pc</p>	 <p><b>8</b> 1pc</p>
 <p><b>9</b> 1pc</p>	 <p><b>10</b> 2pcs</p>	 <p><b>11</b> 1pc</p>	 <p><b>12</b> 1pc</p>
 <p><b>13</b> 1pc</p>	 <p><b>14</b> 1pc</p>	 <p><b>15</b> 1pc</p>	 <p><b>16</b> 1pc</p>
 <p><b>17</b> 1pc</p>	 <p><b>18</b> 1pc</p>	 <p><b>19</b> 1pc</p>	 <p><b>20</b> 3pcs</p>

 <b>21</b> 1pc	 <b>22</b> 1pc	 <b>23</b> 1pc	 <b>24</b> 1pc
 <b>25</b> 1pc	 <b>26</b> 2pcs	 <b>27</b> 1pc	

### Liste des pièces

 <b>A</b> 58pcs	 <b>B</b> M7X50MM 22pcs	 <b>C</b> 58pcs	 <b>P</b> M3. 5X12MM 36pcs	 <b>Q</b> 4pcs
 <b>U</b> 12pcs	 <b>Y</b> 1.5" 4pcs	 <b>Z</b> φ20 58pcs		

## ÉTAPE D'ASSEMBLAGE

# 1

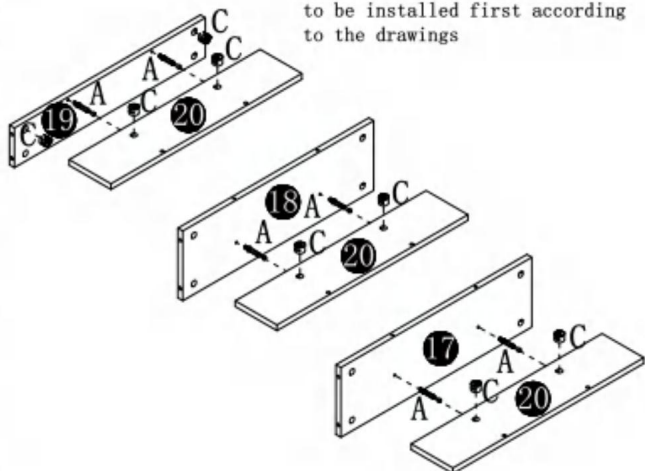
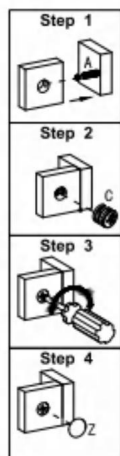

Please note that for Board 19, two accessories numbered C need to be installed first according to the drawings

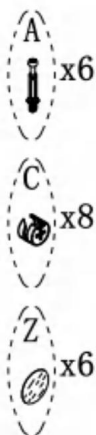

# 2

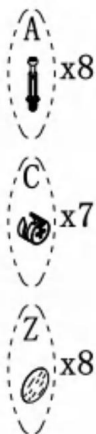
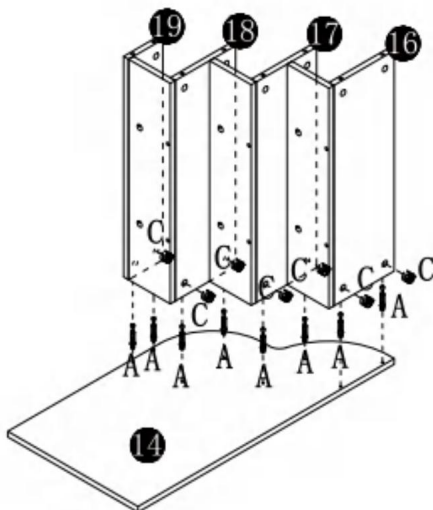
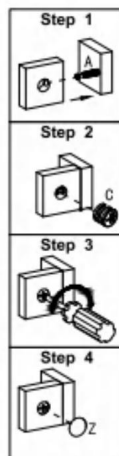

3

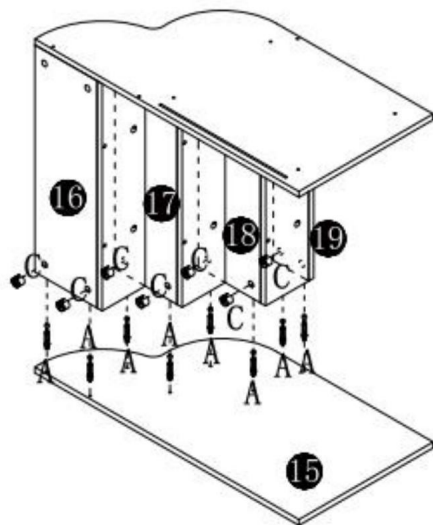
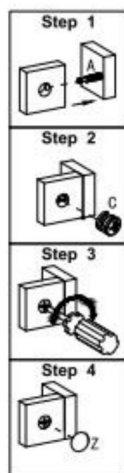

4

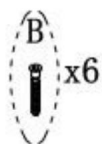
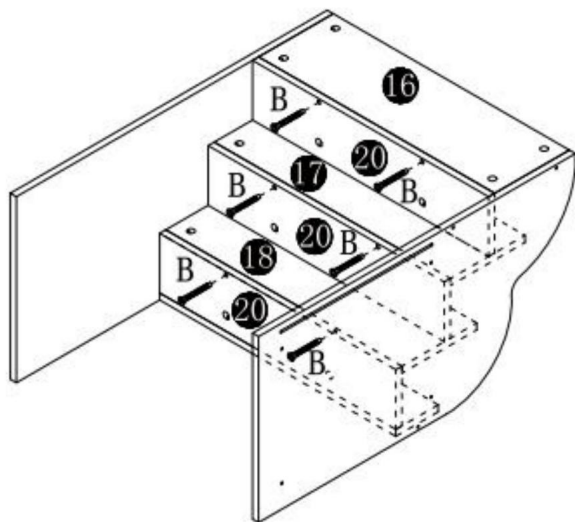

5

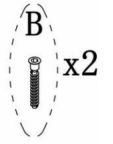
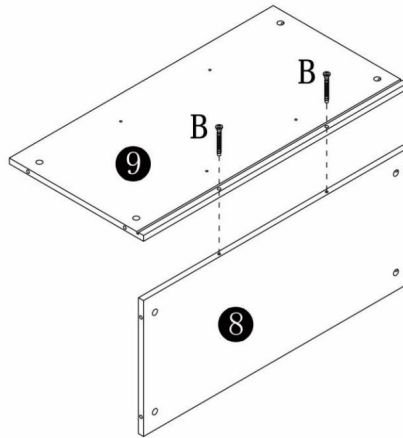

6

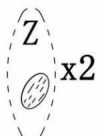
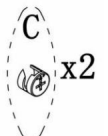
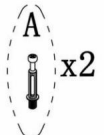
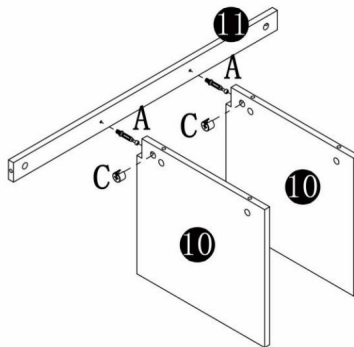
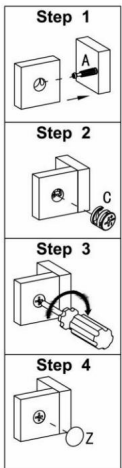

7

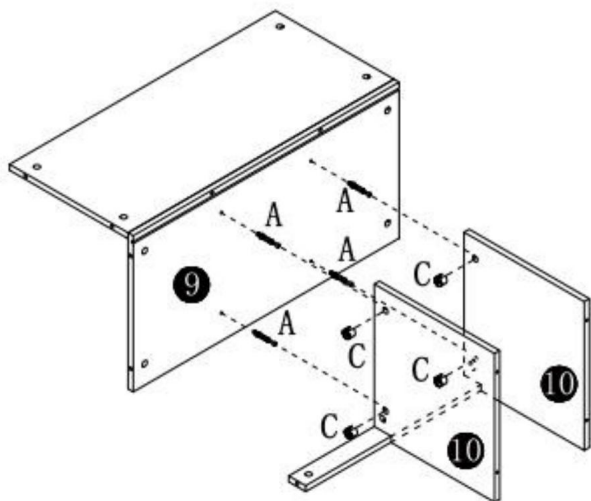
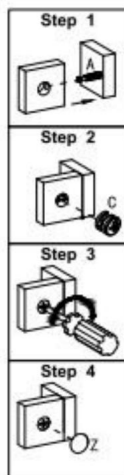

8

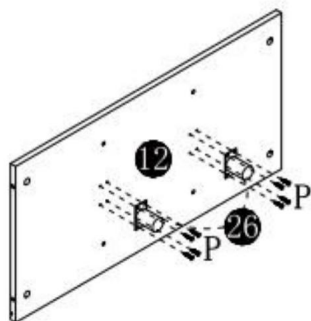
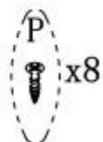

9

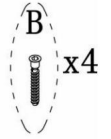
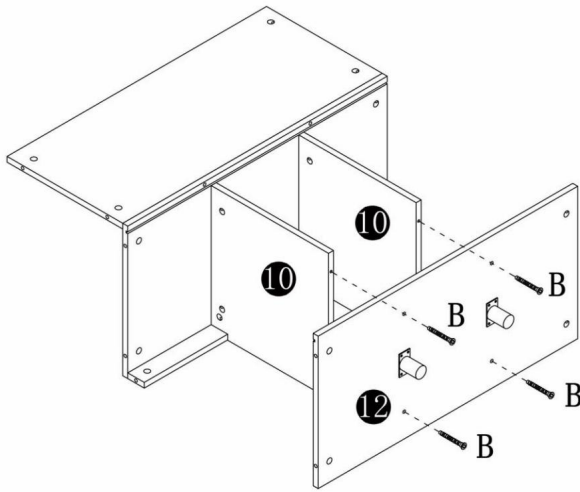

10

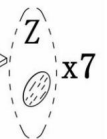
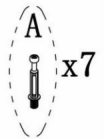
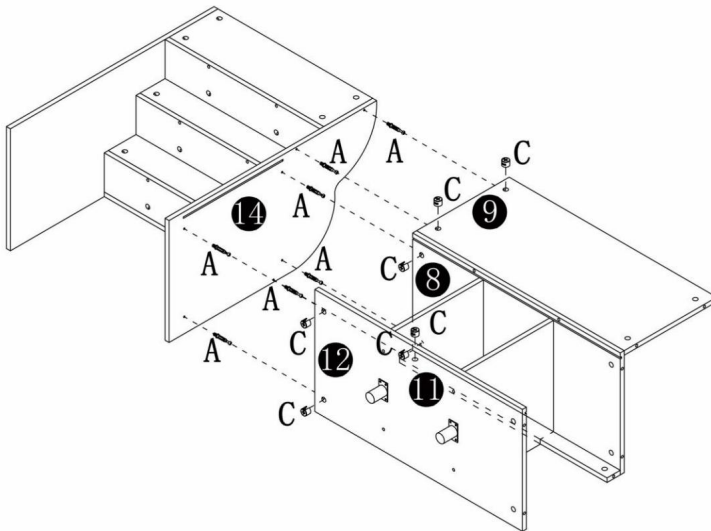
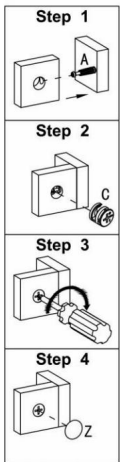

11

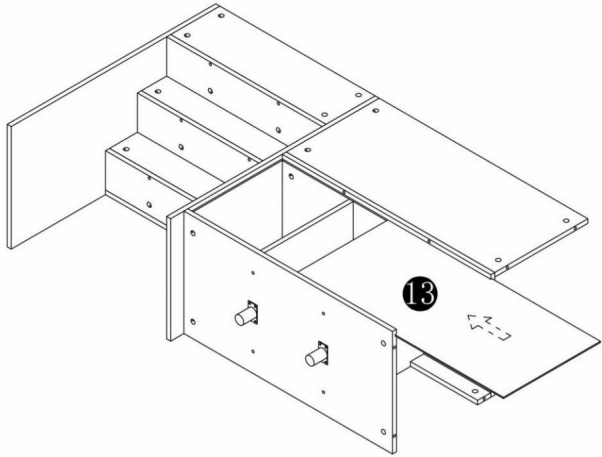

12

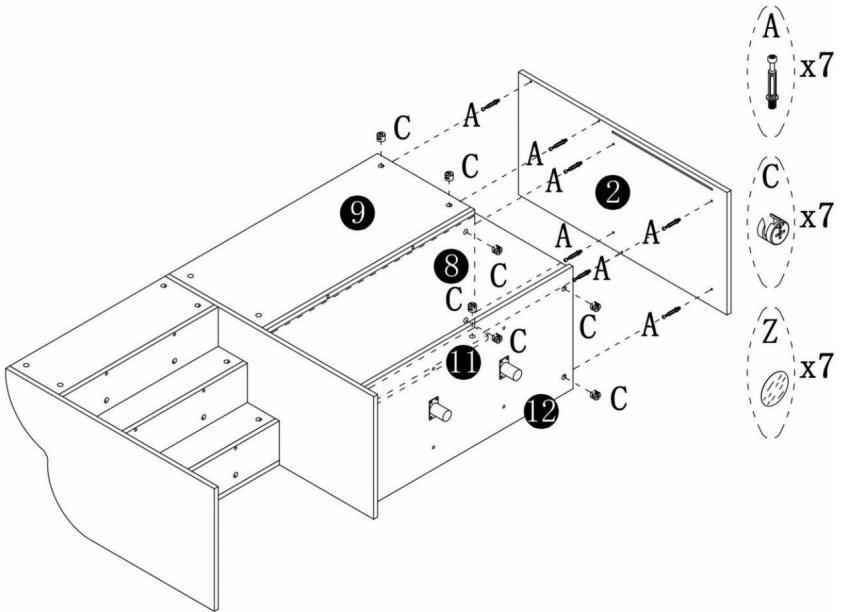
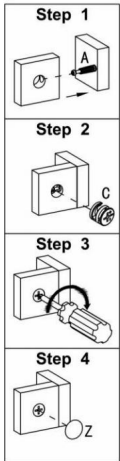

13

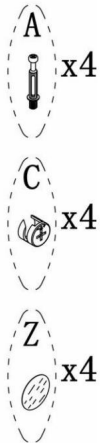
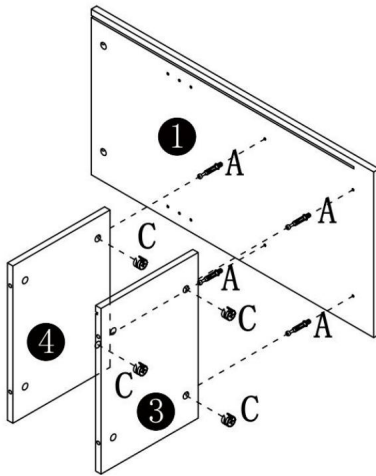
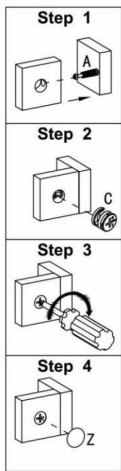

14

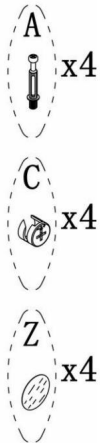
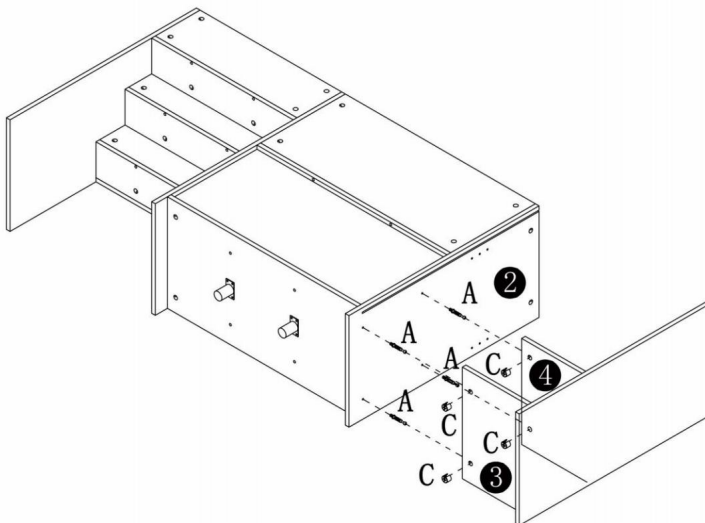
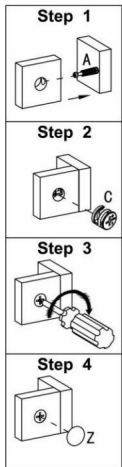

15

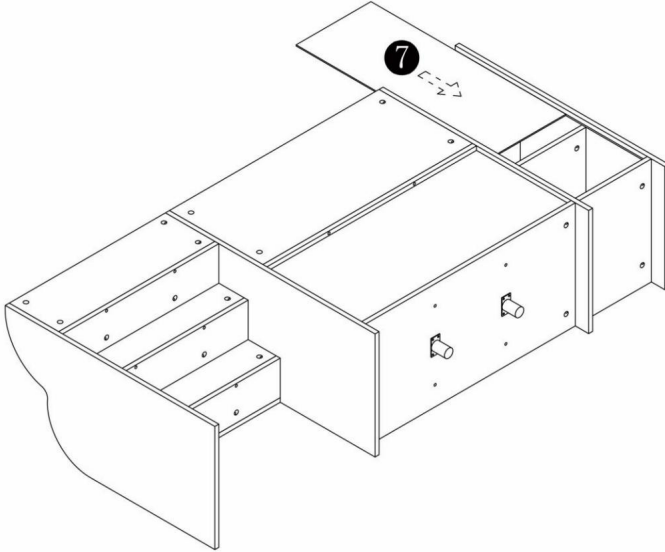

16

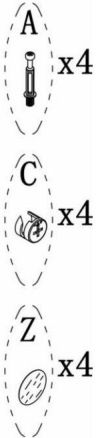
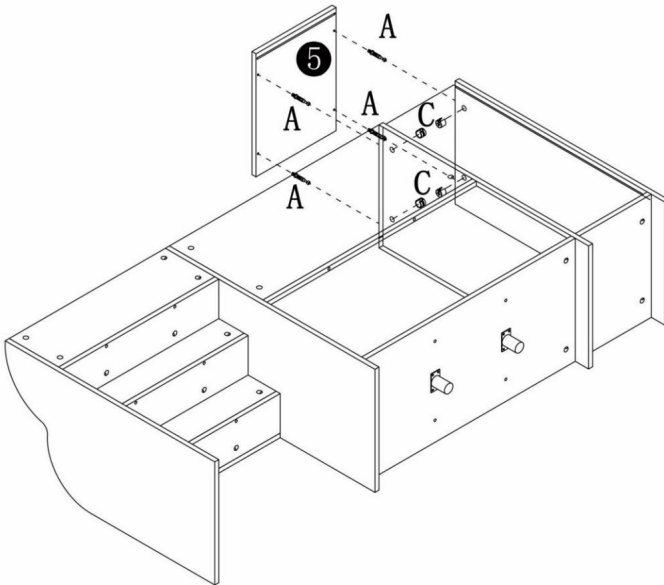
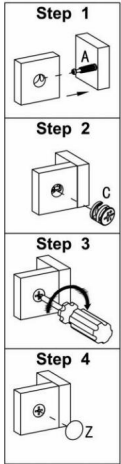

17

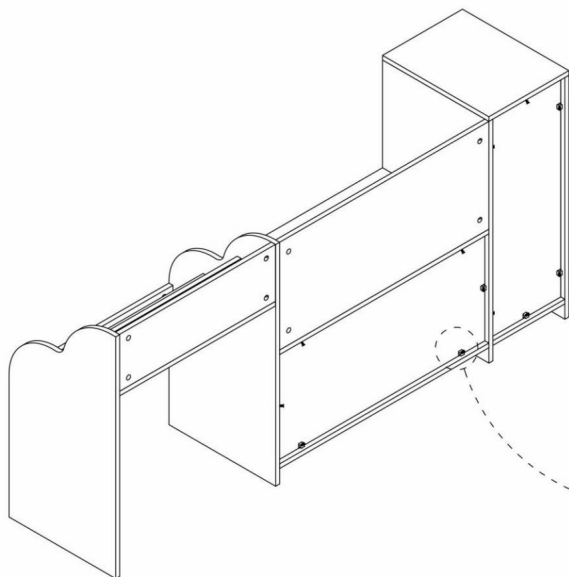

U  
x12

P  
x12

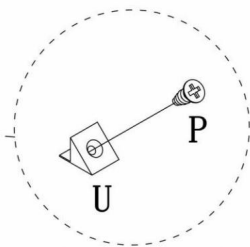

18

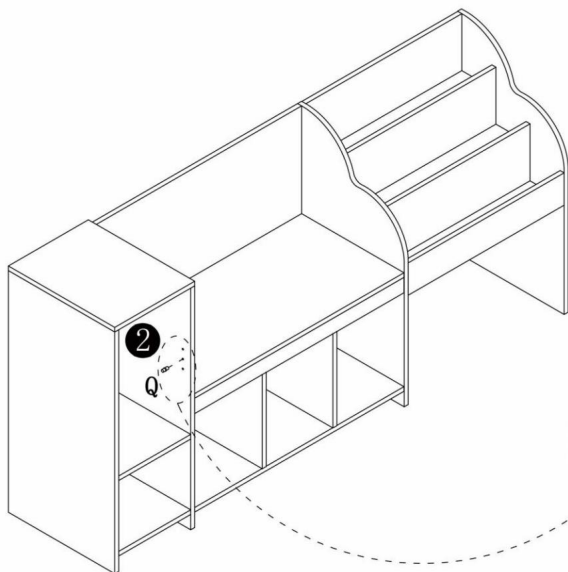

Q  
x4

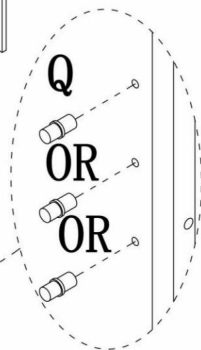

19

L'étagère mobile peut être placée dans trois positions.

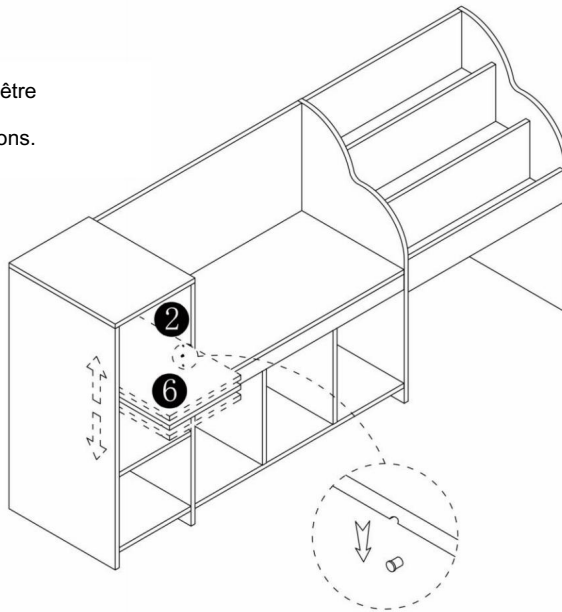

20

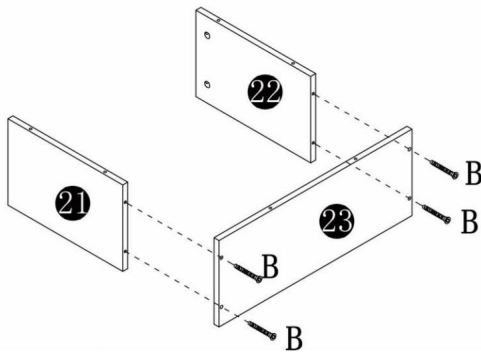
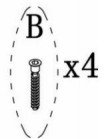

21

Les roues directionnelles ne peuvent se déplacer que vers l'avant et vers l'arrière, tandis que les roues non universelles ne peuvent pas tourner à 360 degrés.

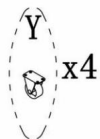
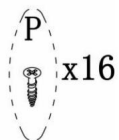
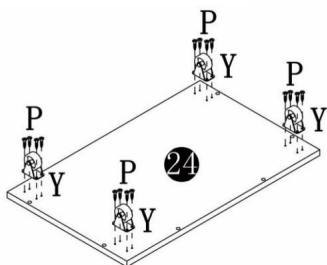

22

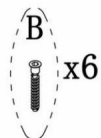
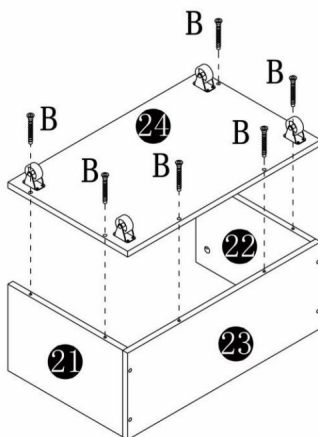

23

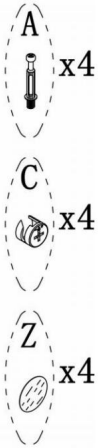
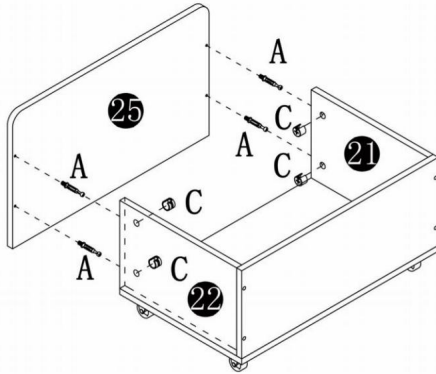
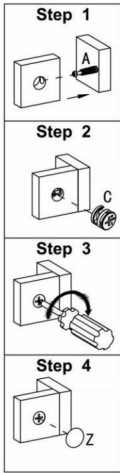

24

Le coussin de toilette est zippé et amovible pour le nettoyage.

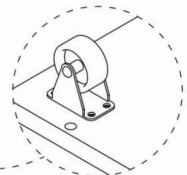
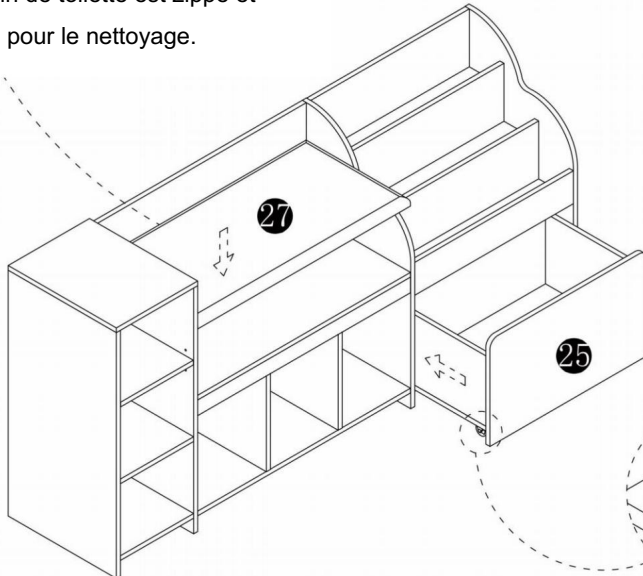

## PARAMÈTRE DU PRODUIT

Modèle	C250224D-01
Charge statique	MAX 350 lb
Couleur	Blanc
Taille du produit	1700 × 400 × 800 mm

Fabricant : Guangzhou Dingxin Office Furniture Co., LTD Adresse du fabricant : No. 1700, Renhe Road, Aotou Town, Conghua District, Guangzhou, Guangdong Province Importé en Australie : SIHAO PTY LTD. 1 ROKEVA STREET, ASTWOOD NSW 2122 Australie

Importé aux États-Unis : Sanven Technology Ltd. Suite 250, 9166 Anaheim Place, Rancho Cucamonga, CA 91730

REPRÉSENTANT	DU ROYAUME-UNI
--------------	----------------

YH CONSULTING LIMITED. A/S YH Consulting Limited, bureau 147, Centurion House, London Road, Staines-upon-Thames, Surrey, TW18 4AX

REPRÉSENTANT	DE LA CE
--------------	----------

E-CrossStu GmbH  
Mainzer Landstr.69,  
60329 Francfort-sur-le-Main.



# VEVOR

**Affordable. Reliable. Home Improvement.**





**KINDER-AUFBEWAHRUNGSBÄNKE**

**MODELL: C250224D-01**

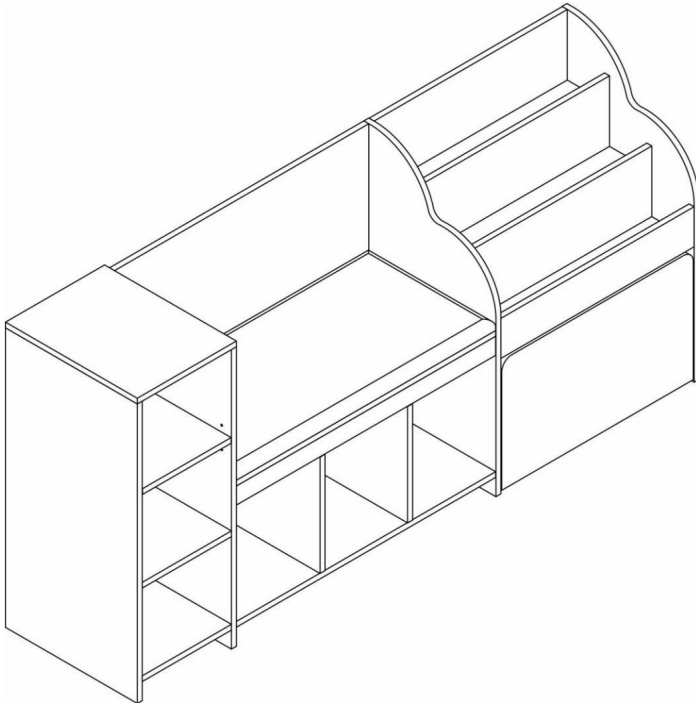
MODELL: C250224D-01



Dies ist die Originalanleitung. Bitte lesen Sie alle Anweisungen sorgfältig durch, bevor Sie das Gerät in Betrieb nehmen. VEVOR behält sich eine klare Auslegung unserer Bedienungsanleitung vor. Das Aussehen des Produkts hängt vom gelieferten Produkt ab. Bitte haben Sie Verständnis dafür, dass wir Sie nicht erneut über Technologie- oder Software-Updates informieren.

	<p>Warnung - Um das Verletzungsrisiko zu verringern, muss der Benutzer Lesen Sie die Bedienungsanleitung sorgfältig durch.</p> <p><b>Hinweis: Montage durch Erwachsene erforderlich!</b></p>
	<p>Die Konformität erfolgt durch eine CE-Sicherheitszertifizierung.</p>
<p><b>Alter</b></p>	<p>3 Jahre +</p>

## SICHERHEITSHINWEISE

### WARNUNG:

**Lesen Sie dieses Material, bevor Sie dieses Produkt verwenden. Die Nichtbeachtung kann zu schweren Verletzungen führen.**

### Vorsichtsmaßnahmen bei der Montage

1. Die Montage muss gemäß dieser Anleitung erfolgen. Unsachgemäße Montage kann Gefahren verursachen.
2. Halten Sie den Versammlungsbereich sauber und gut beleuchtet.
3. Die Produkteigenschaften gelten für ordnungsgemäß und vollständig montierte Nur Produkte.
4. Montieren Sie das Gerät auf einer flachen, ebenen, harten und glatten Oberfläche, auf der es sicher Unterstützung der Kinder-Aufbewahrungsbänke.
5. Weitere Informationen zu den im Folgenden aufgeführten Teilen finden Sie  
Seiten finden Sie im Montagediagramm dieses Handbuchs. Auspacken  
und trennen Sie alle Teile in einem sauberen Arbeitsbereich.

### Vorsichtsmaßnahmen treffen

1. Setzen oder stellen Sie sich nicht auf diesen Artikel.
2. Dieses Produkt ist kein Spielzeug. Erlauben Sie Kindern nicht, mit diesem Produkt zu spielen oder in der Nähe Artikel.
3. Überschreiten Sie nicht die angegebene Gewichtskapazität.
4. Nur auf einer flachen, ebenen, harten und glatten Oberfläche verwenden, die sicher unterstützen eine voll beladene Kinder-Aufbewahrungsbank.
5. Nur bestimmungsgemäß verwenden.
6. Vor jedem Gebrauch prüfen; nicht verwenden, wenn Teile lose oder beschädigt sind.

**BEWAHREN SIE DIESES HANDBUCH AUF**

## MONTAGE VON NOCKEN UND STIFTEN

Schrauben Sie den Stift in die Bohrung. Um die Nocken richtig einzustellen, achten Sie darauf, dass der Pfeil auf der Nocke zum Loch des Stifts zeigt, den sie verriegelt. Verriegeln Sie die Nocke, indem Sie den Nockenkopf mit einem Schraubendreher drehen, bis er fest sitzt. Bitte verwenden Sie keinen elektrischen Schraubendreher, um das Gerät zusammenzubauen.

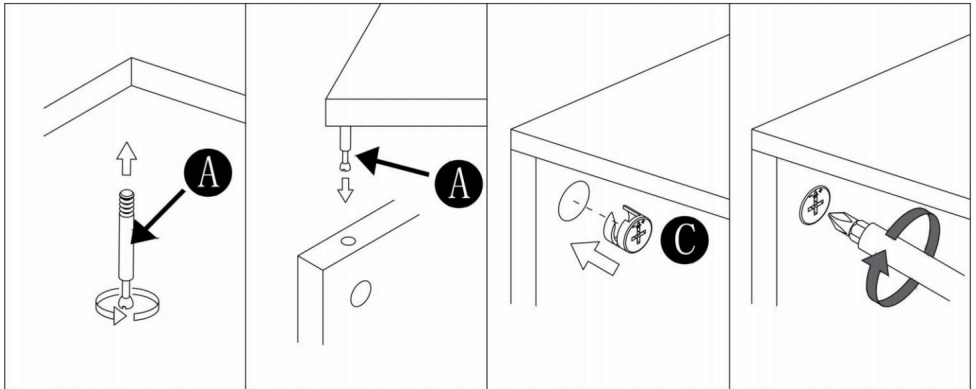



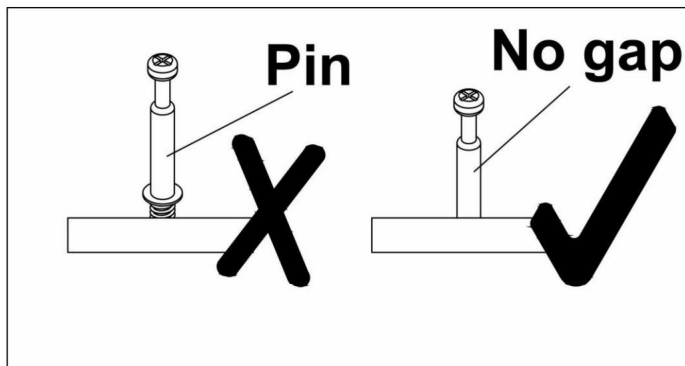



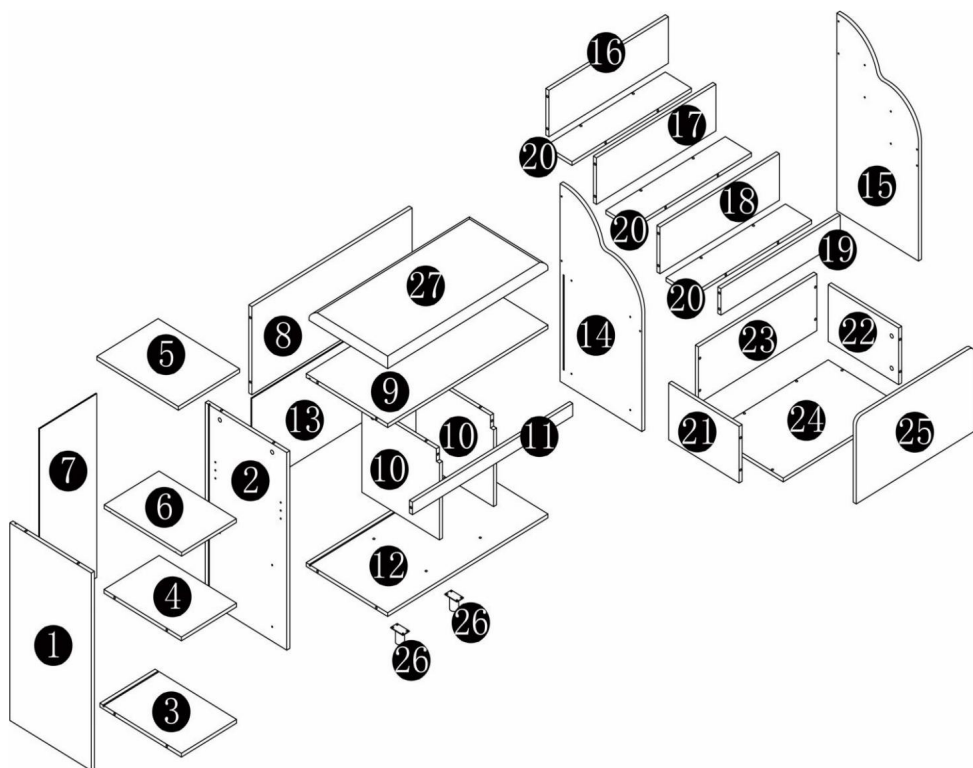



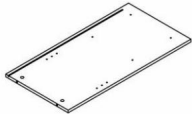
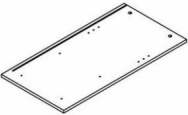

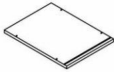
Lesen Sie jeden Schritt sorgfältig durch, bevor Sie beginnen. Es ist sehr wichtig, dass jeder Schritt der Anleitung in der richtigen Reihenfolge ausgeführt wird. Wenn diese Schritte nicht in der richtigen Reihenfolge ausgeführt werden, treten Montageschwierigkeiten auf.

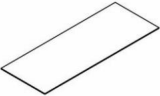



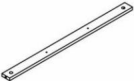
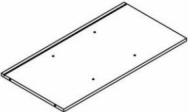
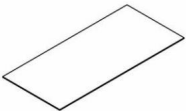
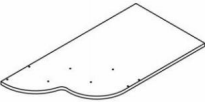
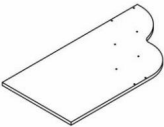

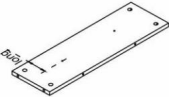
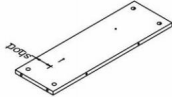
## TEILE- UND HARDWARELISTE

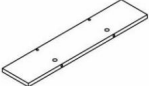



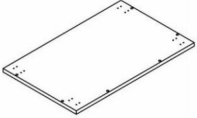

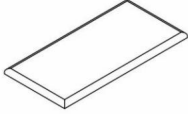





# Hardwareliste

 <b>1</b> 1pc	 <b>2</b> 1pc	 <b>3</b> 1pc	 <b>4</b> 1pc
 <b>5</b> 1pc	 <b>6</b> 1pc	 <b>7</b> 1pc	 <b>8</b> 1pc
 <b>9</b> 1pc	 <b>10</b> 2pcs	 <b>11</b> 1pc	 <b>12</b> 1pc
 <b>13</b> 1pc	 <b>14</b> 1pc	 <b>15</b> 1pc	 <b>16</b> 1pc
 <b>17</b> 1pc	 <b>18</b> 1pc	 <b>19</b> 1pc	 <b>20</b> 3pcs

 <b>21</b> 1pc	 <b>22</b> 1pc	 <b>23</b> 1pc	 <b>24</b> 1pc
 <b>25</b> 1pc	 <b>26</b> 2pcs	 <b>27</b> 1pc	

## Teilleiste

 <b>A</b> 58pcs	 <b>B</b> M7X50MM 22pcs	 <b>C</b> 58pcs	 <b>P</b> M3.5X12MM 36pcs	 <b>Q</b> 4pcs
 <b>U</b> 12pcs	 <b>Y</b> 1.5" 4pcs	 <b>Z</b> φ20 58pcs		

# MONTAGESTRITT

1

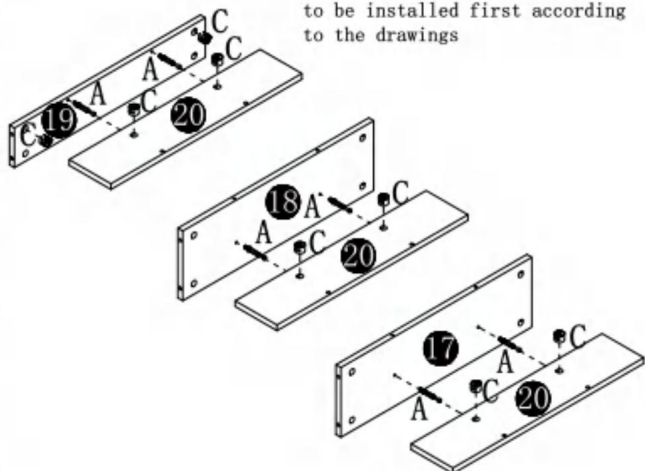
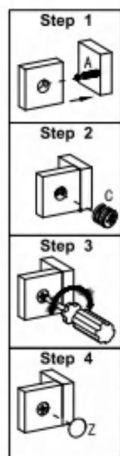

Please note that for Board 19, two accessories numbered C need to be installed first according to the drawings

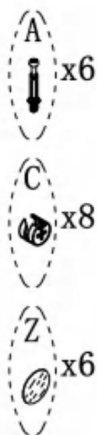

2

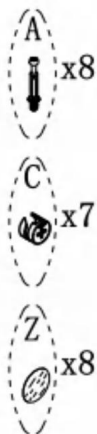
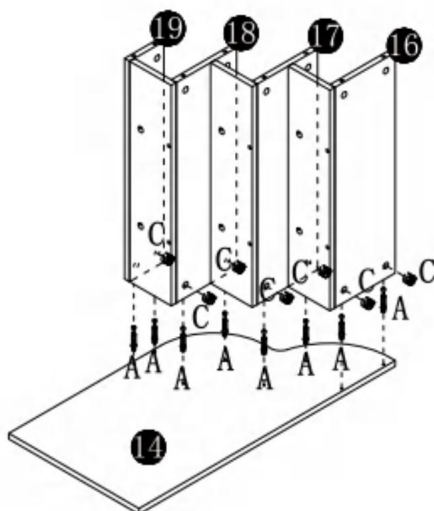
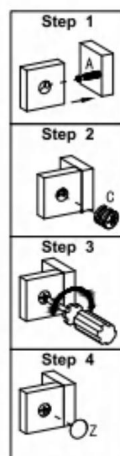

3

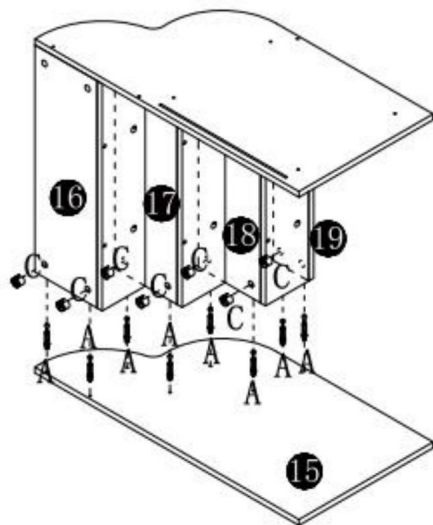
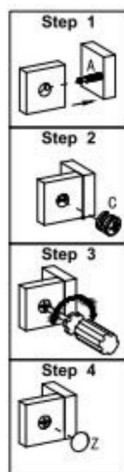

4

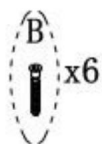
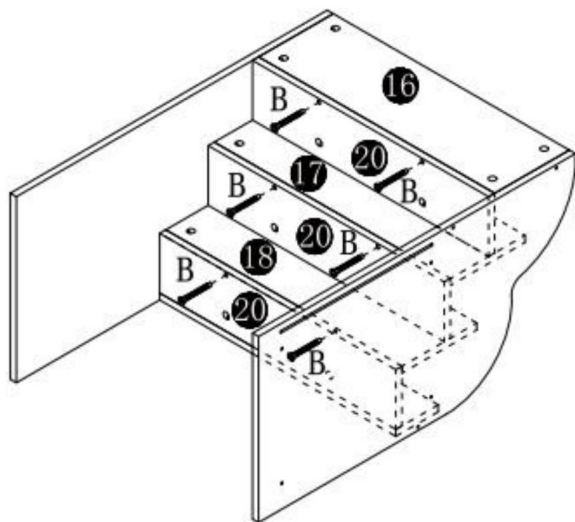

5

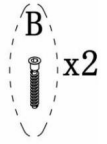
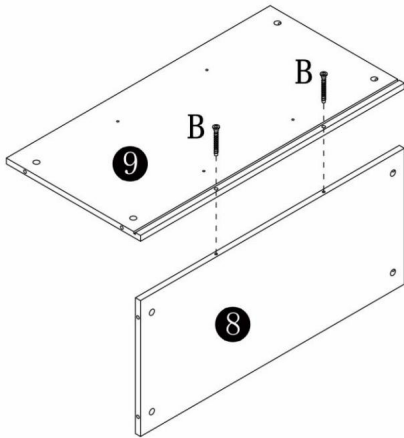

6

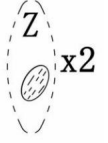
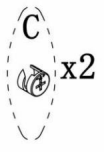
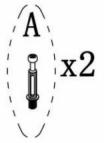
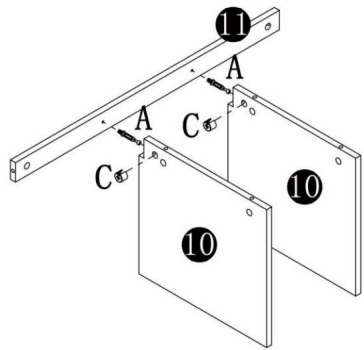
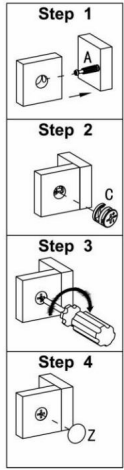

7

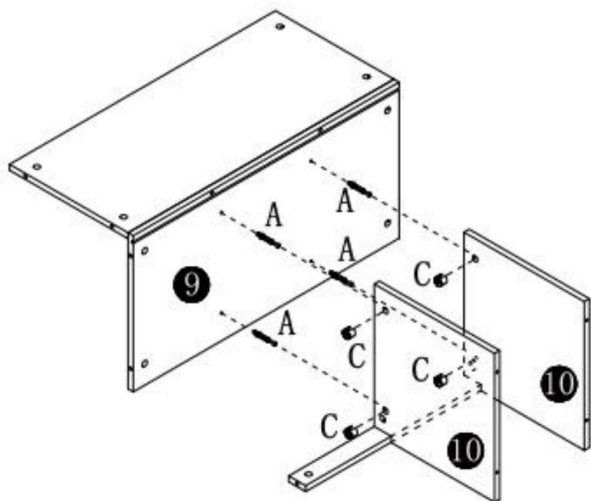
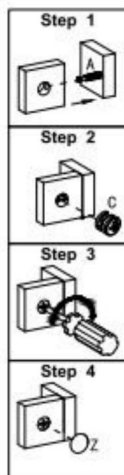

8

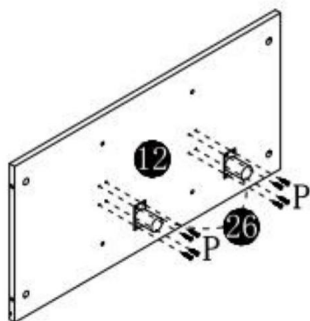
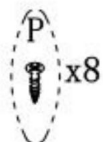

9

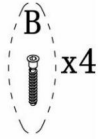
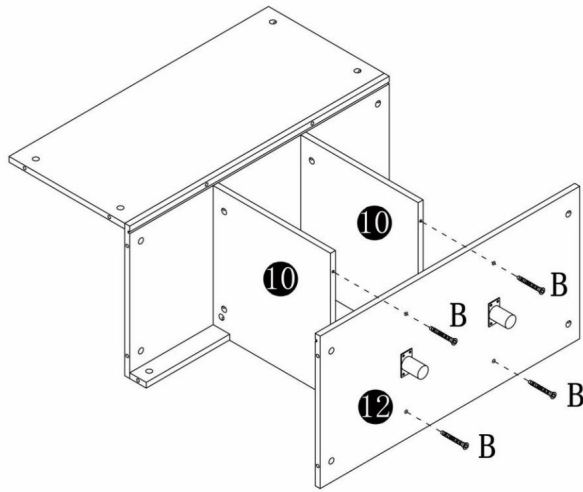

10

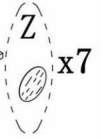
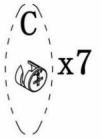
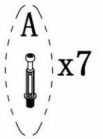
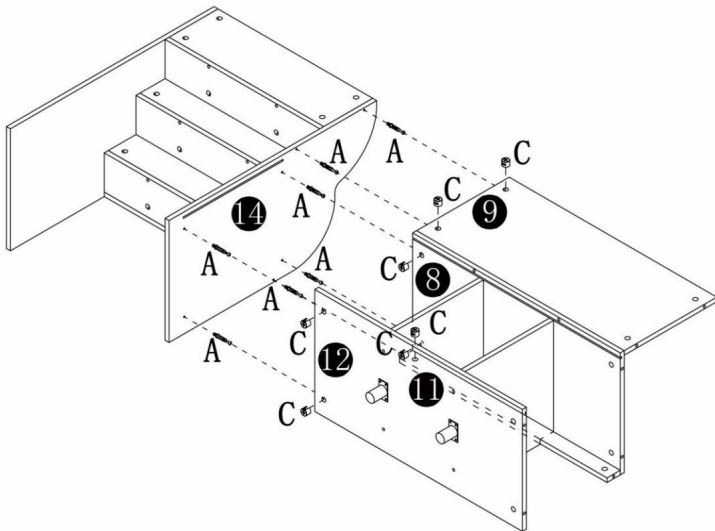
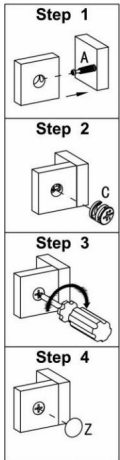

11

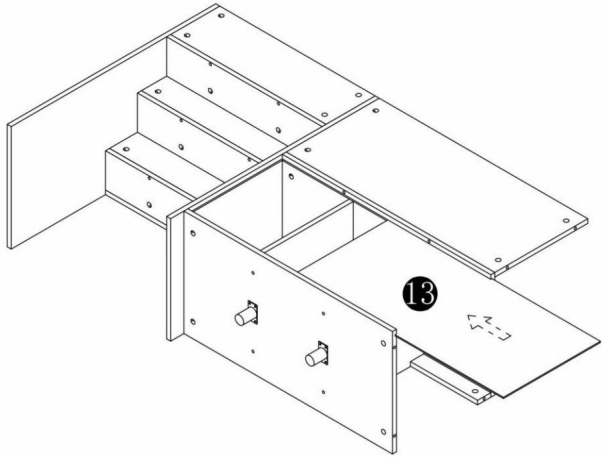

12

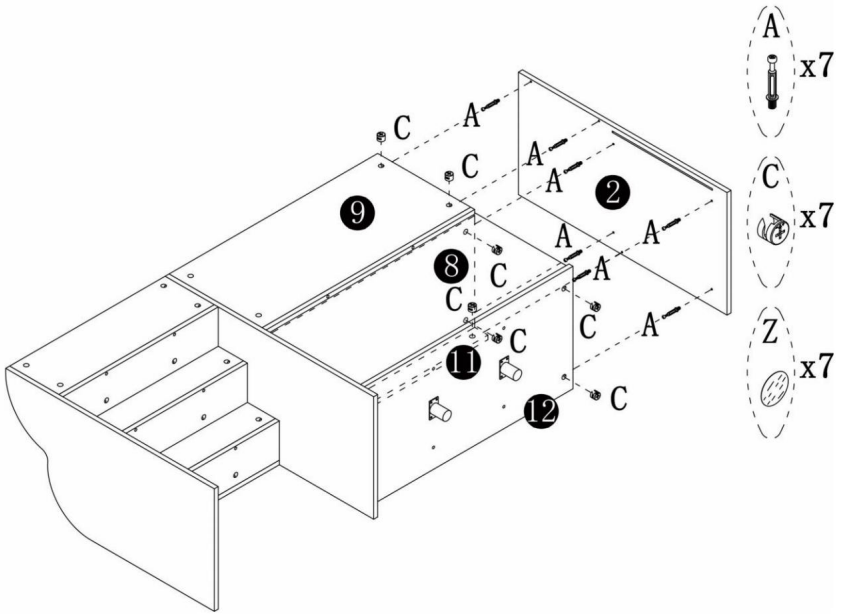
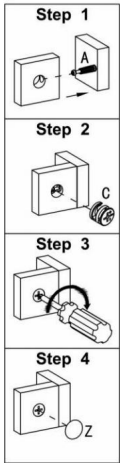

# 13

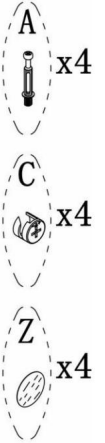
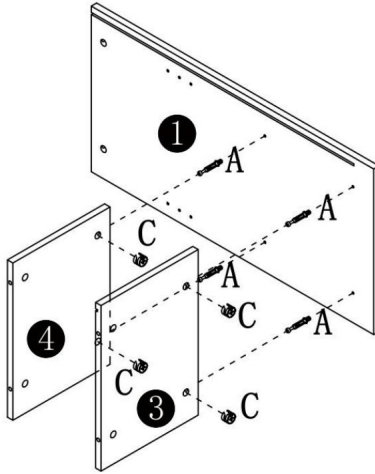
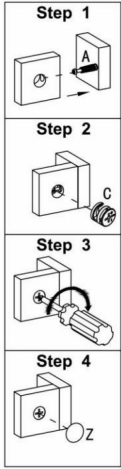

# 14

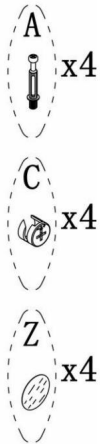
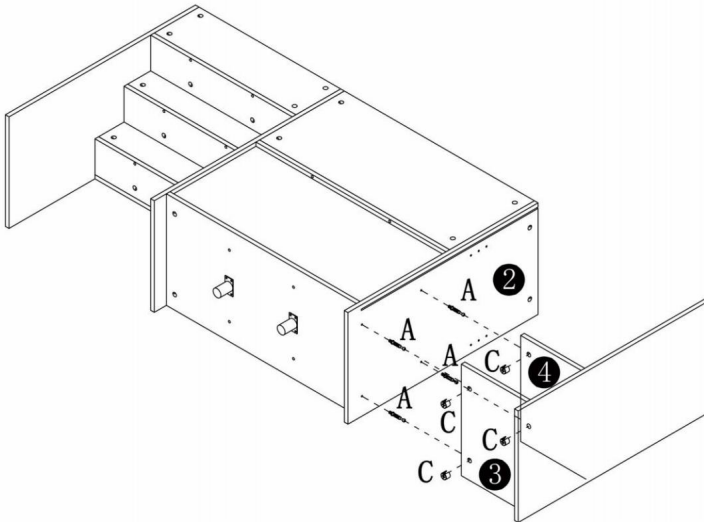
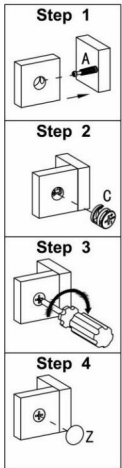

15

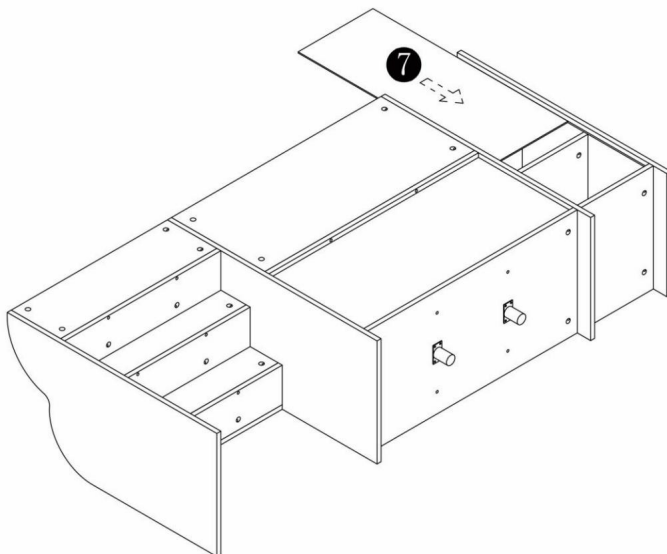

16

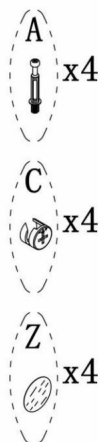
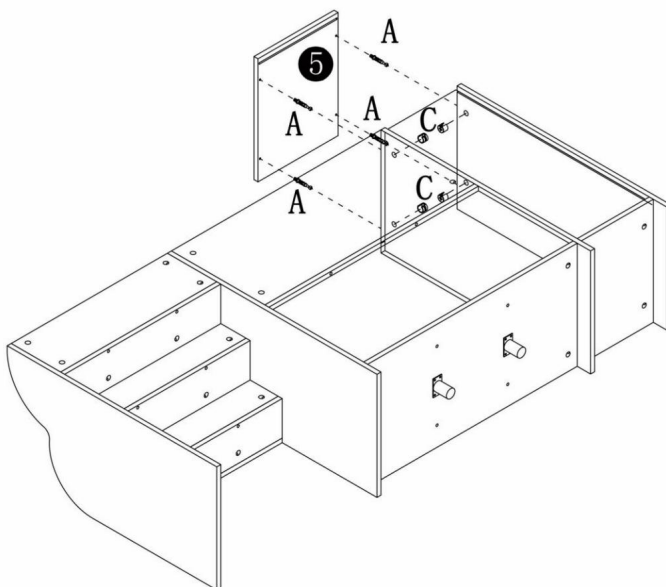
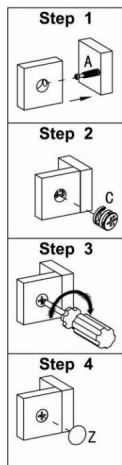

17

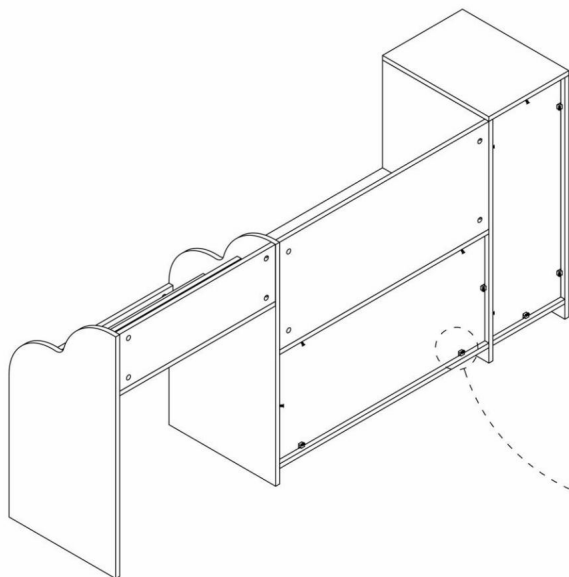

U  
x12

P  
x12

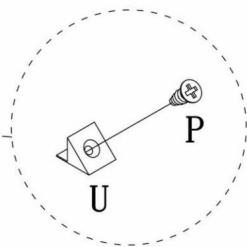

18

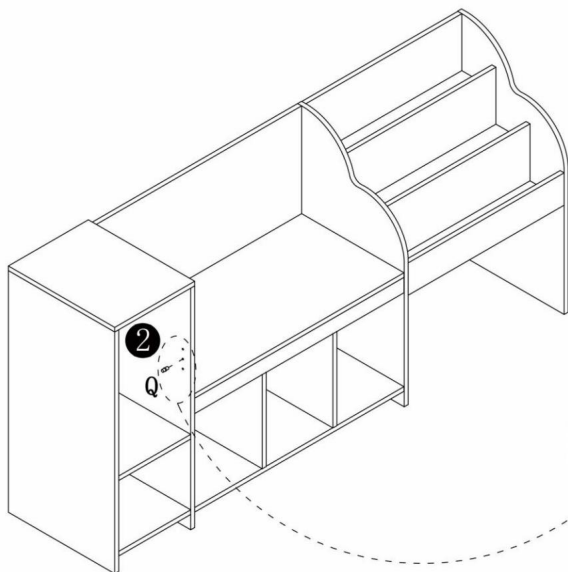

Q  
x4

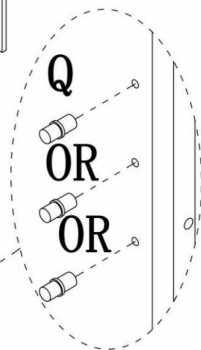

19

Das verschiebbare Regal kann  
an drei Positionen platziert.

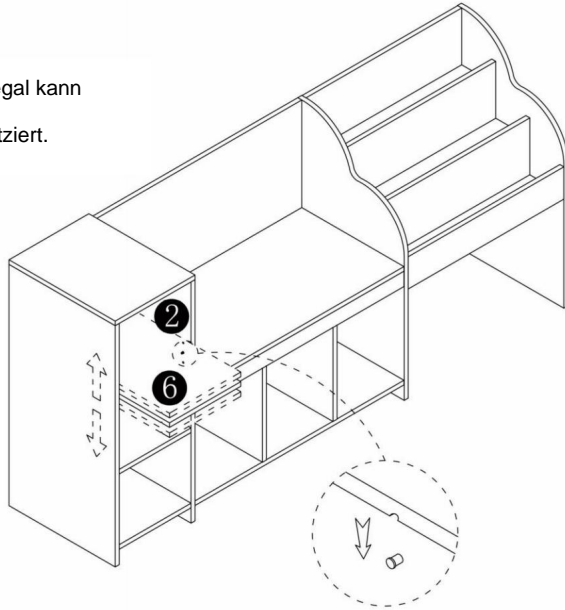

20

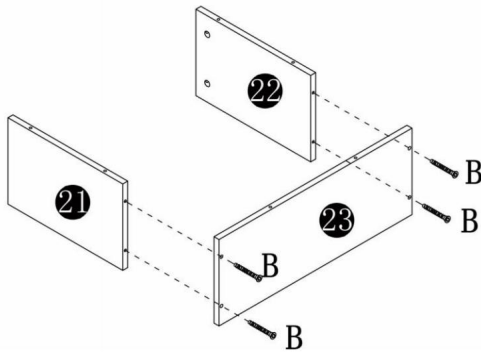

# 21

Richtungsräder können sich nur vorwärts und rückwärts bewegen, während nicht-universelle Räder sich nicht um 360 Grad drehen können.

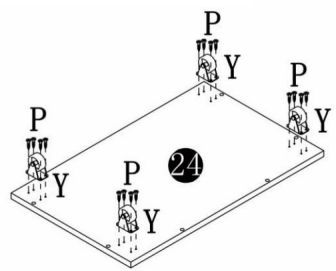
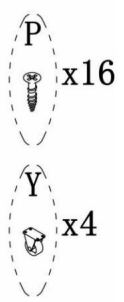

# 22

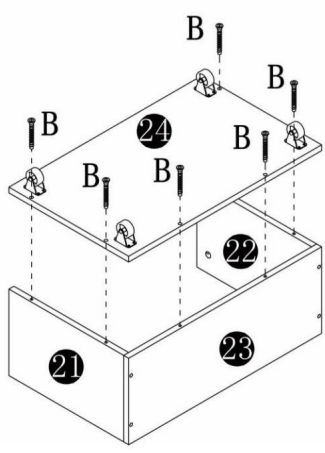
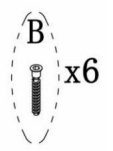

23

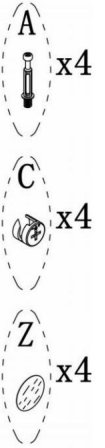
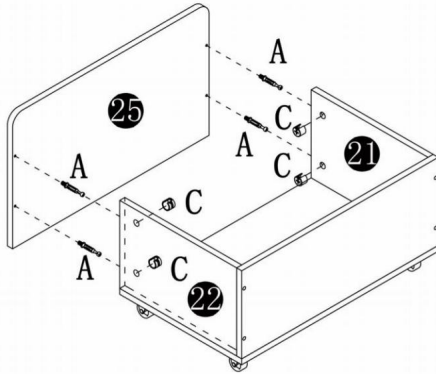
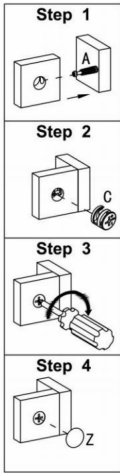

24

Das Sofakissen ist mit einem Reißverschluss versehen und zum Reinigen abnehmbar.

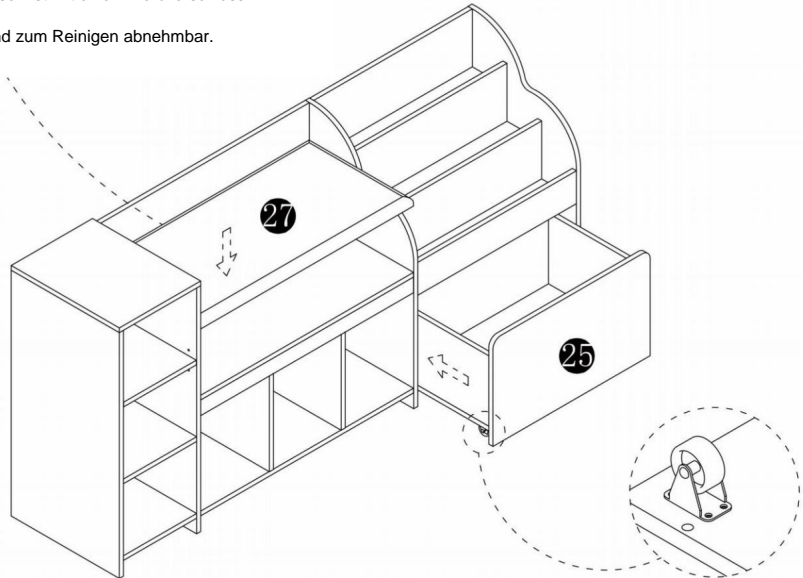

## PRODUKTPARAMETER

<b>Modell</b>	C250224D-01
<b>Statische Tragfähigkeit</b>	MAX. 350 Pfund
<b>Farbe</b>	Weiß
<b>Produktgröße</b>	1700×400×800mm

**Hersteller:** Guangzhou Dingxin Office Furniture Co., LTD. **Adresse des**

**Herstellers:** Nr. 1700, Renhe Road, Aotou Town, Conghua District, Guangzhou, Provinz Guangdong. **Importiert nach Australien:** SIHAO

PTY LTD. 1 ROKEVA STREETEASTWOOD NSW 2122 Australien

**Importiert in die USA:** Sanven Technology Ltd. Suite 250, 9166 Anaheim Place, Rancho Cucamonga, CA 91730



YH CONSULTING LIMITED. C/O YH Consulting Limited,  
Büro 147, Centurion House, London Road, Staines-upon-  
Thames, Surrey, TW18 4AX



E-CrossStu GmbH  
Mainzer Landstr.69,  
60329 Frankfurt am Main.



# VEVOR

**Affordable. Reliable. Home Improvement.**

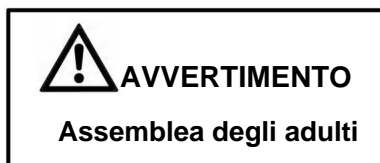

**PANCHE CONTENITORE PER BAMBINI**

**MODELLO: C250224D-01**

# VEVOR



Affordable. Reliable. Home Improvement.

DEPOSITO PER BAMBINI  
PANCHE

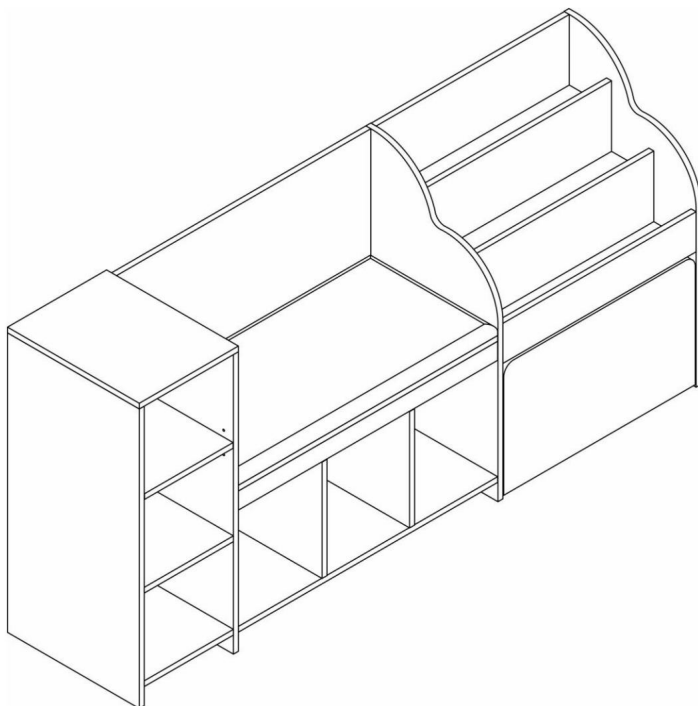
**MODELLO: C250224D-01**



Queste sono le istruzioni originali, si prega di leggere attentamente tutte le istruzioni del manuale prima dell'uso. VEVOR si riserva la piena interpretazione del proprio manuale utente. L'aspetto del prodotto dipenderà dal prodotto ricevuto. Vi preghiamo di scusarci se non vi informeremo più in caso di aggiornamenti tecnologici o software sul nostro prodotto.

	<p>Avvertenza: per ridurre il rischio di lesioni, l'utente deve leggere attentamente il manuale di istruzioni.</p> <p><b>Nota: è richiesto il montaggio da parte di un adulto!</b></p>
	<p>La conformità è una certificazione di sicurezza CE.</p>
<p><b>Età</b></p>	<p>3 anni +</p>

## ISTRUZIONI DI SICUREZZA

### AVVERTIMENTO:

**Leggere attentamente questo materiale prima di utilizzare il prodotto. In caso contrario, si potrebbe provocare lesioni gravi.**

### Precauzioni di montaggio

1. Montare solo secondo queste istruzioni. Montaggio improprio può creare pericoli.
2. Mantenere l'area di assemblaggio pulita e ben illuminata.
3. Le capacità del prodotto si applicano a prodotti correttamente e completamente assemblati solo prodotti.
4. Montare su una superficie piana, livellata, dura e liscia in grado di resistere in modo sicuro a supporto delle panche portaoggetti per bambini.
5. Per ulteriori informazioni riguardanti le parti elencate di seguito pagine, fare riferimento allo schema di montaggio di questo manuale. Disimballare e separare tutte le parti in un'area di lavoro pulita.

### Precauzioni d'uso

1. NON SEDERSI O STARE IN PIEDI SU QUESTO OGGETTO.
2. Questo prodotto non è un giocattolo. Non permettere ai bambini di giocare con o vicino a questo prodotto. articolo.
3. Non superare le capacità di peso specificate.
4. Utilizzare solo su una superficie piana, livellata, dura e liscia che possa essere utilizzata in sicurezza supportare una panca portaoggetti per bambini completamente carica.
5. Utilizzare solo come previsto.
6. Ispezionare prima di ogni utilizzo; non utilizzare se alcune parti sono allentate o danneggiate.

**CONSERVARE QUESTO MANUALE**

## INSTALLAZIONE DI CAMME E PERNI

Avvitare il perno nel foro. Per impostare correttamente le camme, assicurarsi che la freccia sulla camma si apra verso il foro del perno che si sta bloccando. Bloccare la camma ruotando la testa della camma con un cacciavite fino a quando non è serrata. Non utilizzare un cacciavite elettrico. cacciavite per assemblare l'unità.

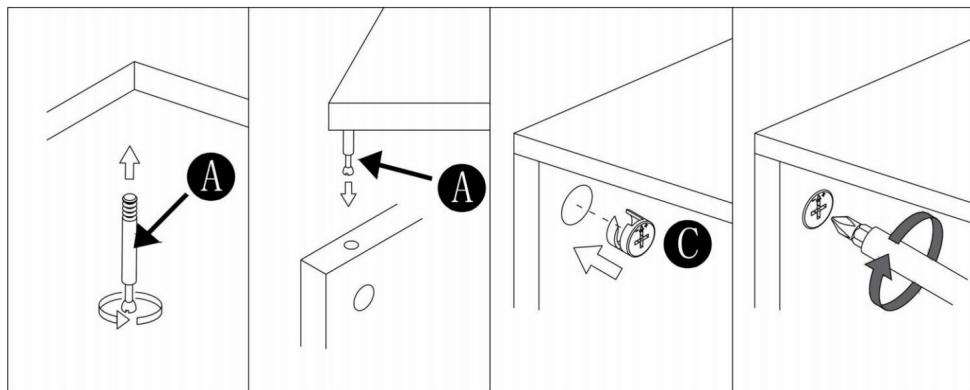



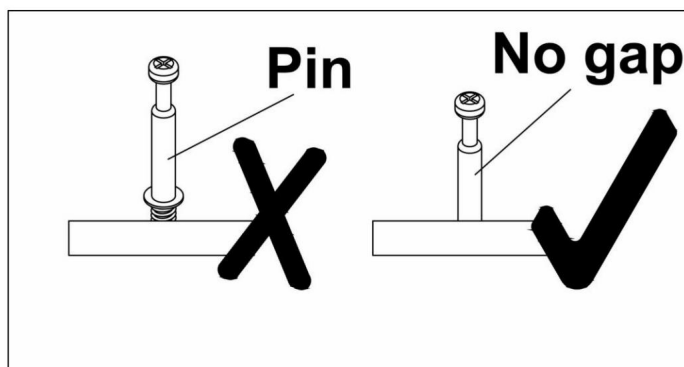



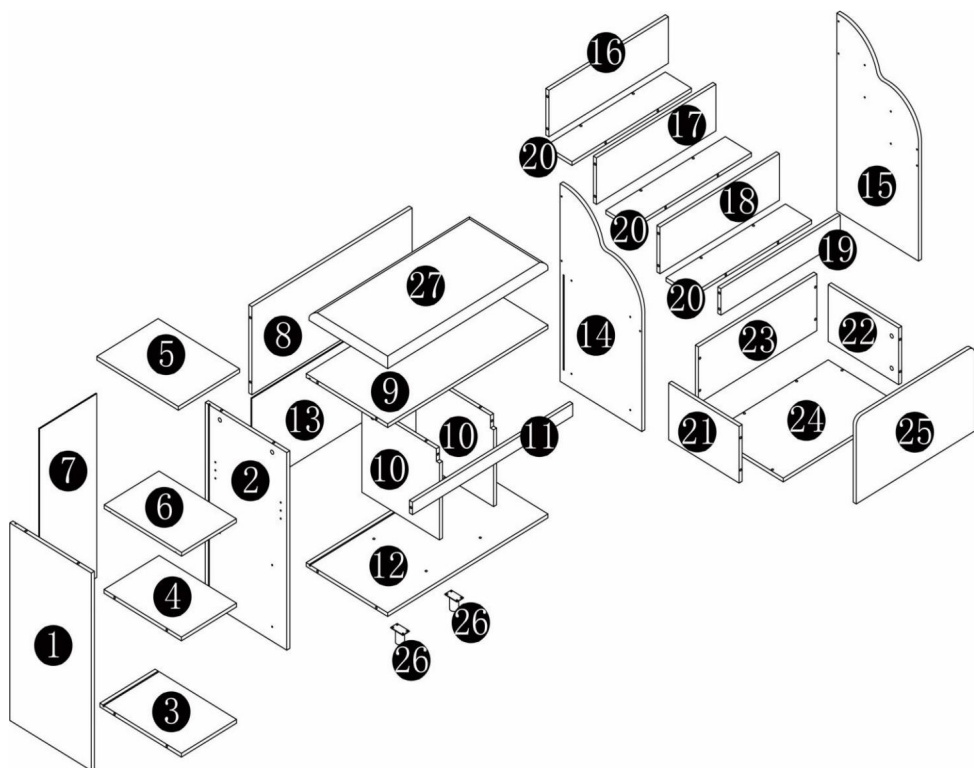



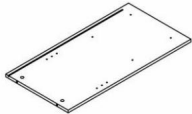
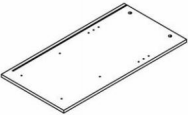

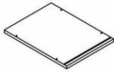
Leggere attentamente ogni passaggio prima di iniziare. È fondamentale che ogni passaggio delle istruzioni venga eseguito nell'ordine corretto. Se non si seguono questi passaggi in sequenza, si verificheranno difficoltà di montaggio.

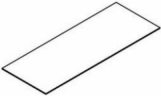



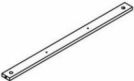
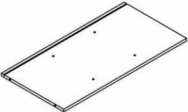
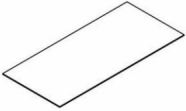

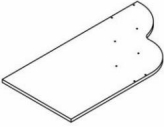

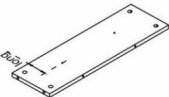
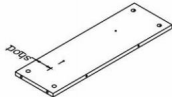
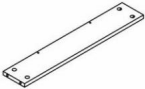
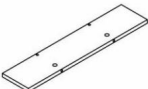
## ELENCO PARTI E HARDWARE







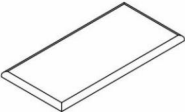





# Elenco hardware

 <b>1</b> 1pc	 <b>2</b> 1pc	 <b>3</b> 1pc	 <b>4</b> 1pc
 <b>5</b> 1pc	 <b>6</b> 1pc	 <b>7</b> 1pc	 <b>8</b> 1pc
 <b>9</b> 1pc	 <b>10</b> 2pcs	 <b>11</b> 1pc	 <b>12</b> 1pc
 <b>13</b> 1pc	 <b>14</b> 1pc	 <b>15</b> 1pc	 <b>16</b> 1pc
 <b>17</b> 1pc	 <b>18</b> 1pc	 <b>19</b> 1pc	 <b>20</b> 3pcs

 <b>21</b> 1pc	 <b>22</b> 1pc	 <b>23</b> 1pc	 <b>24</b> 1pc
 <b>25</b> 1pc	 <b>26</b> 2pcs	 <b>27</b> 1pc	

### Elenco delle parti

 <b>A</b> 58pcs	 <b>B</b> 22pcs	 <b>C</b> 58pcs	 <b>P</b> 36pcs	 <b>Q</b> 4pcs
 <b>U</b> 12pcs	 <b>Y</b> 4pcs	 <b>Z</b> 58pcs		

## FASE DI MONTAGGIO

1

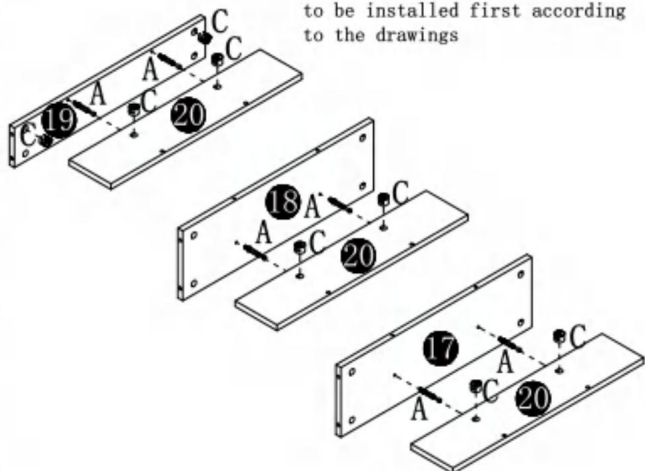
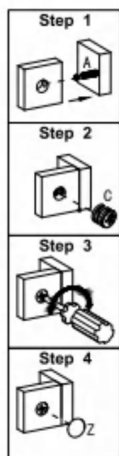

Please note that for Board 19, two accessories numbered C need to be installed first according to the drawings

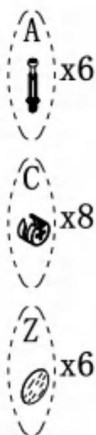

2

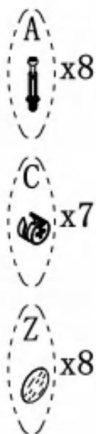
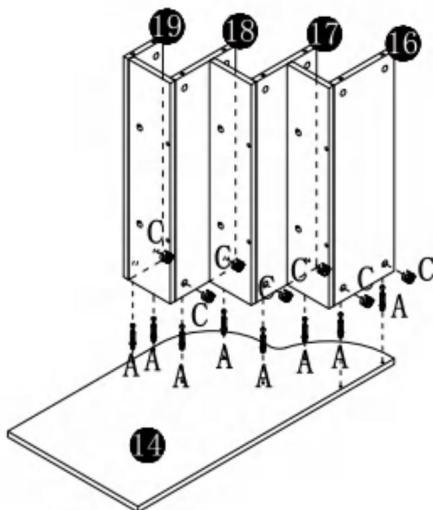
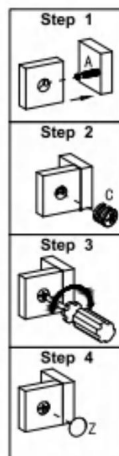

3

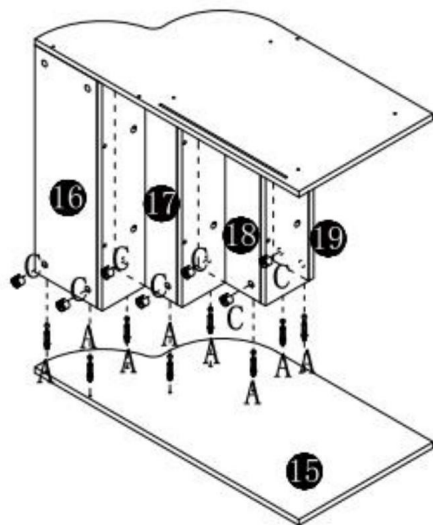
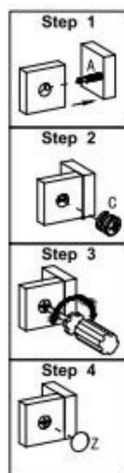

4

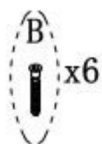
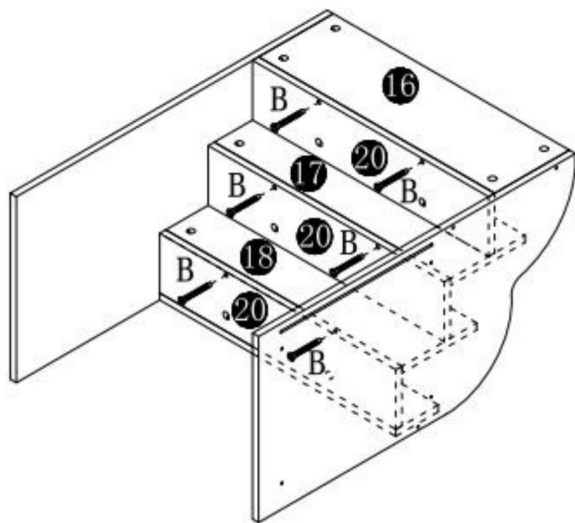

5

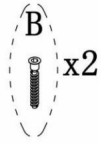
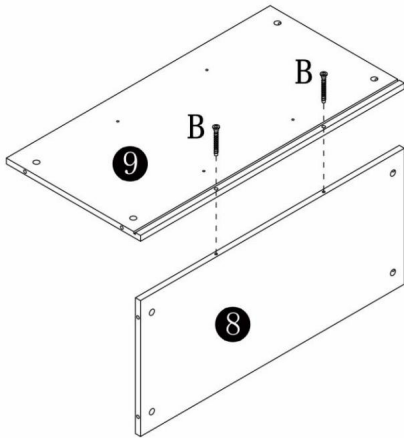

6

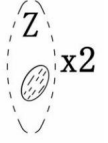
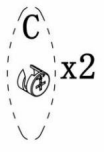
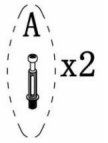
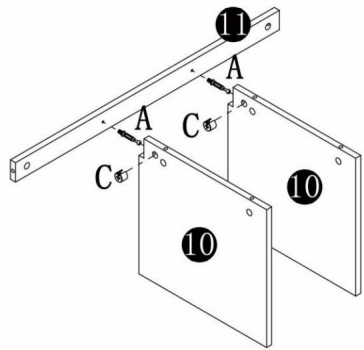
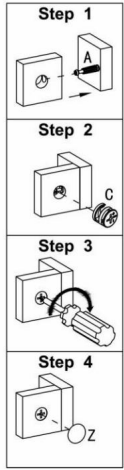

7

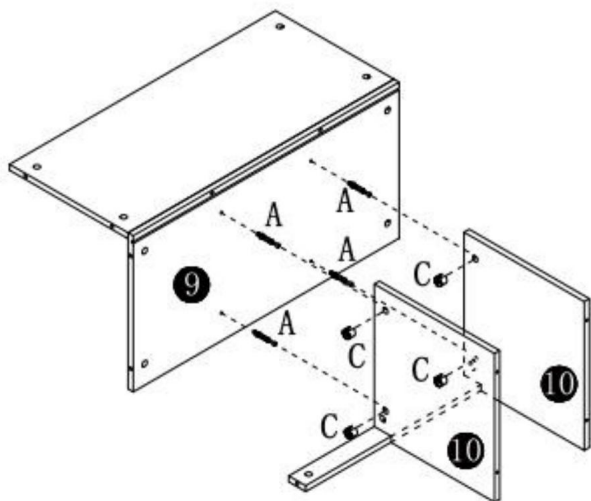
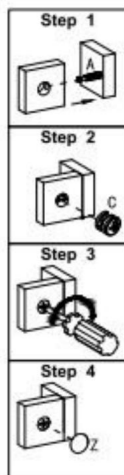

8

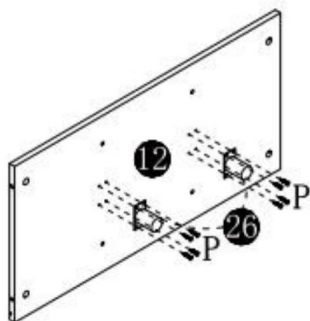
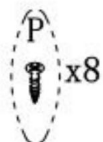

9

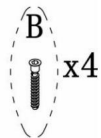
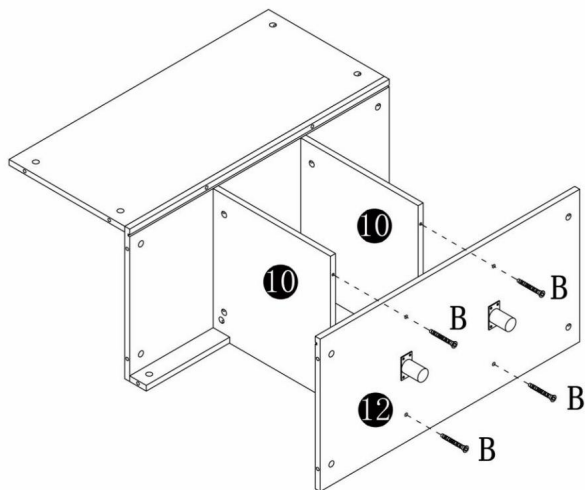

10

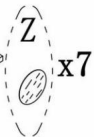
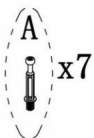
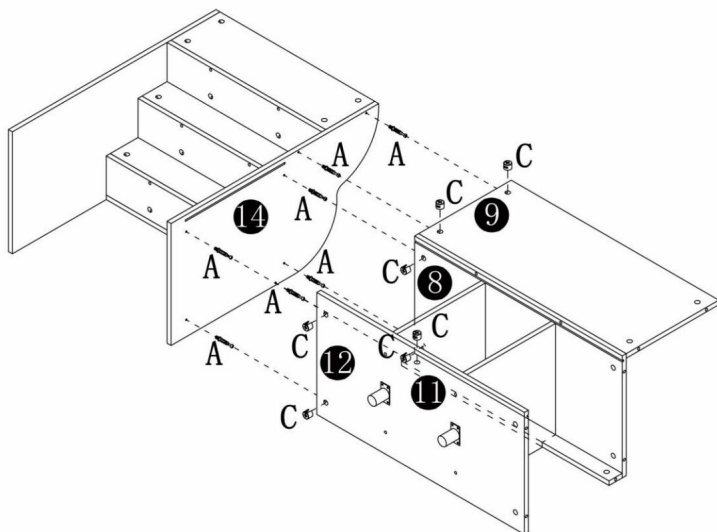
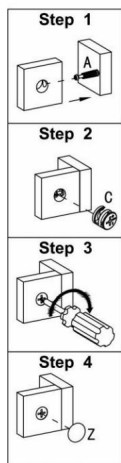

11

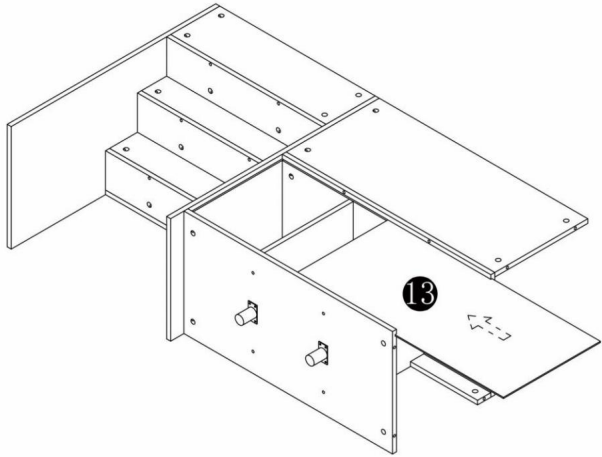

12

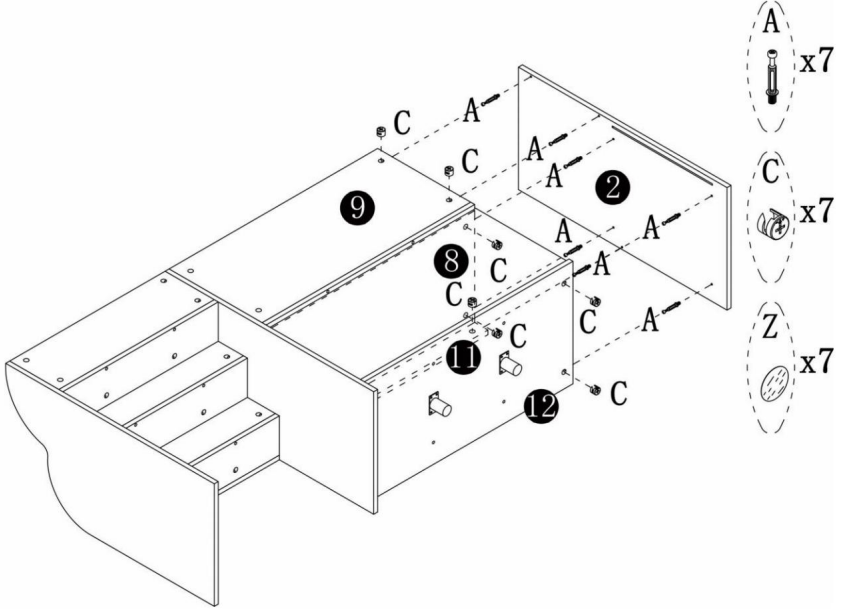
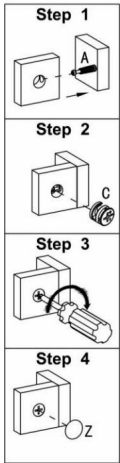

13

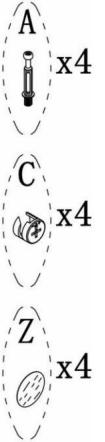
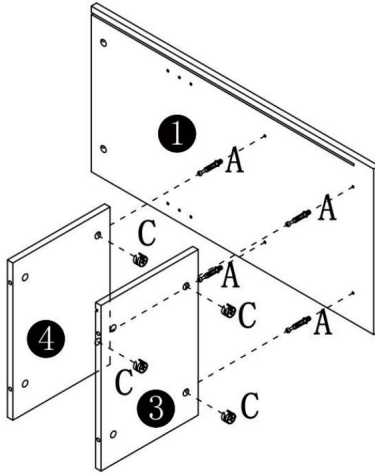
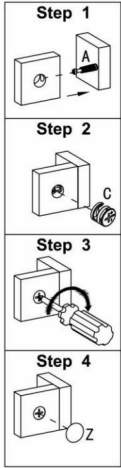

14

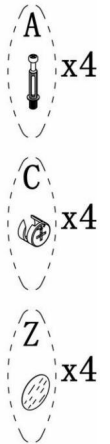
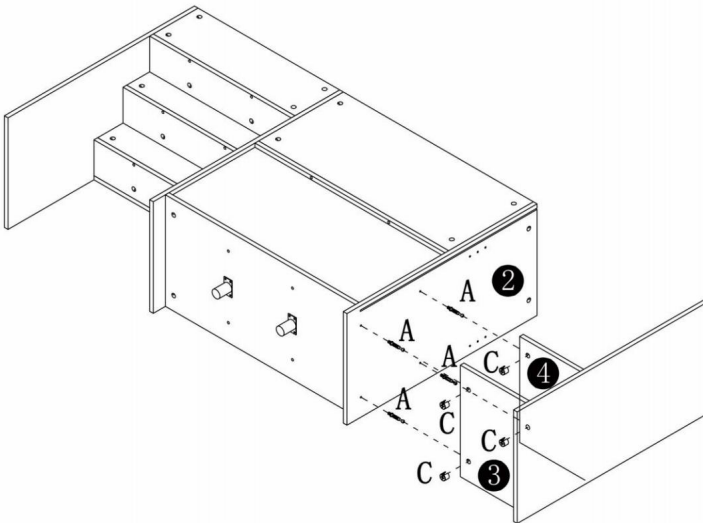
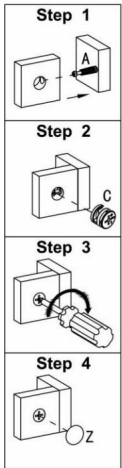

15

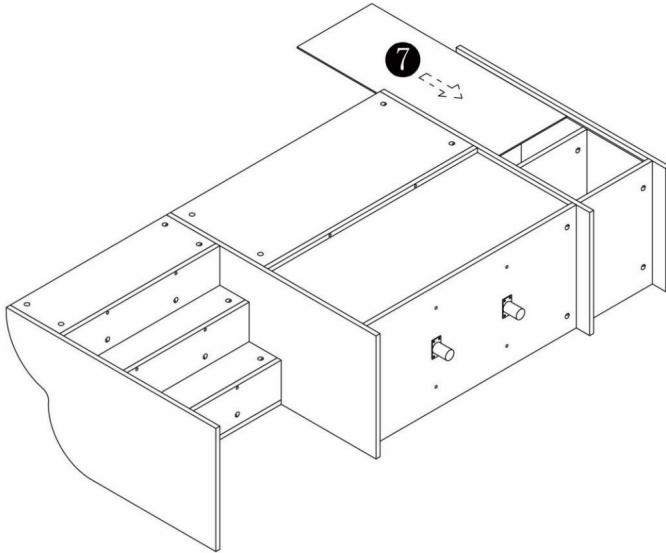

16

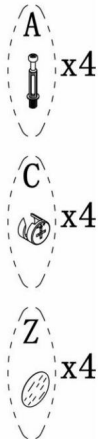
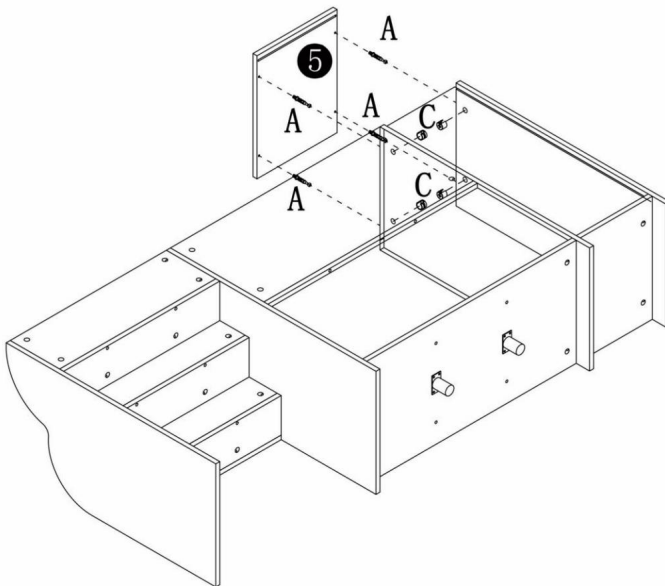
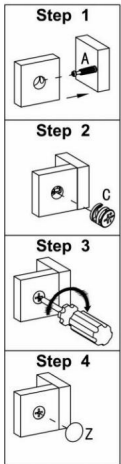

17

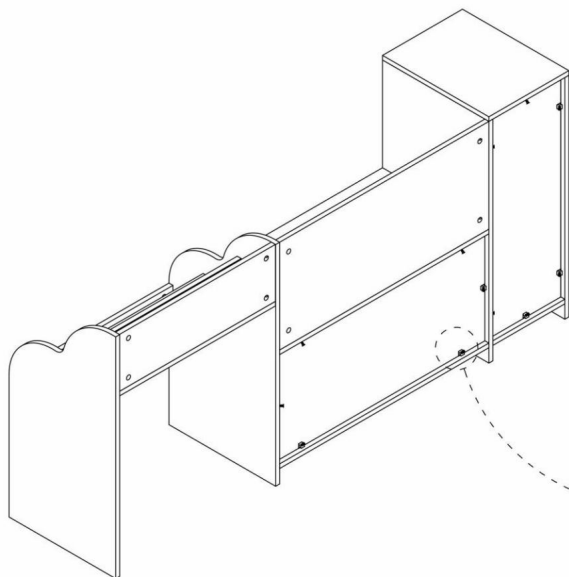

U  
x12

P  
x12

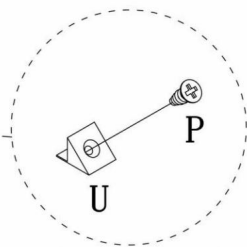

18

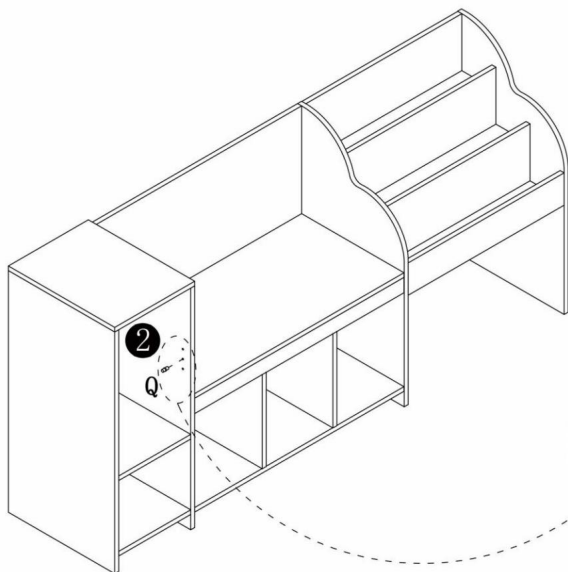

Q  
x4

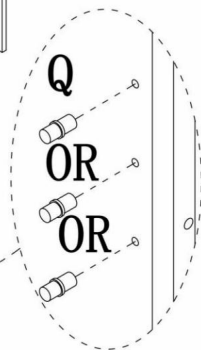

19

Il ripiano mobile può essere collocati in tre posizioni.

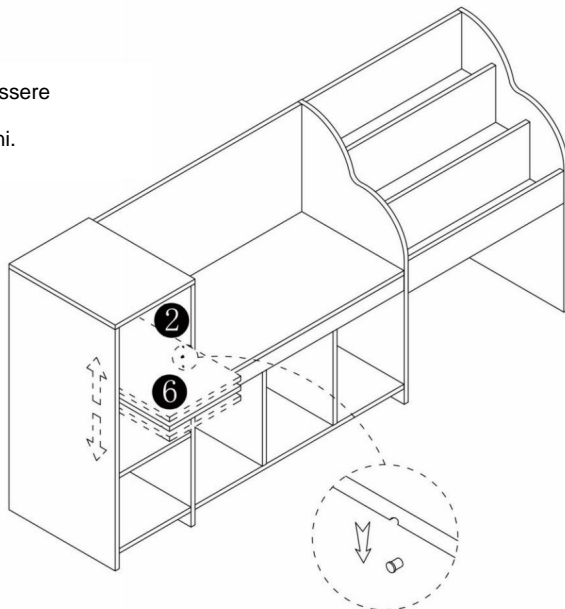

20

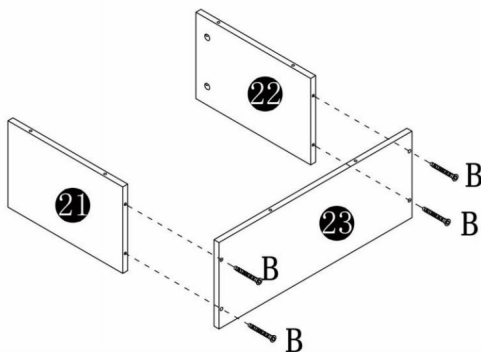
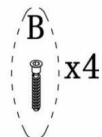

21

Le ruote direzionali possono muoversi solo in avanti e indietro, mentre le ruote non universali non possono ruotare di 360 gradi.

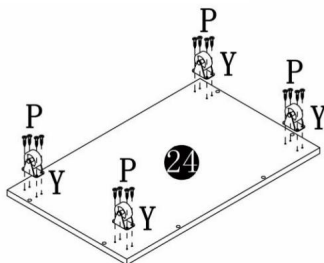
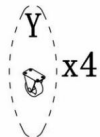
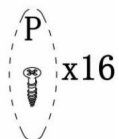

22

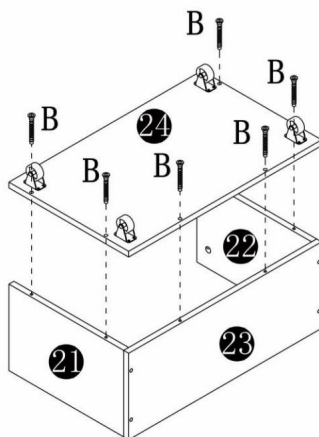
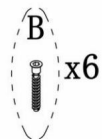

23

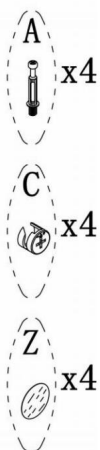
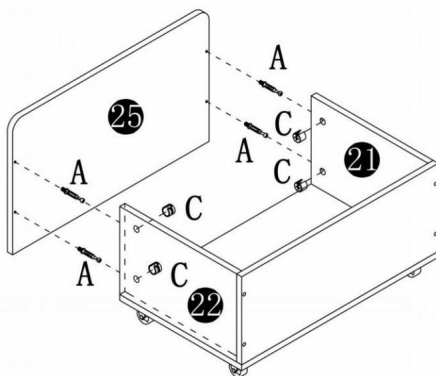
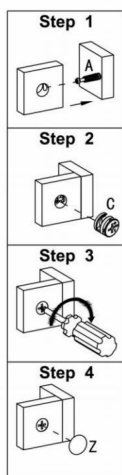

24

Il cuscino di sapone è dotato di cerniera e può essere staccato per la pulizia.

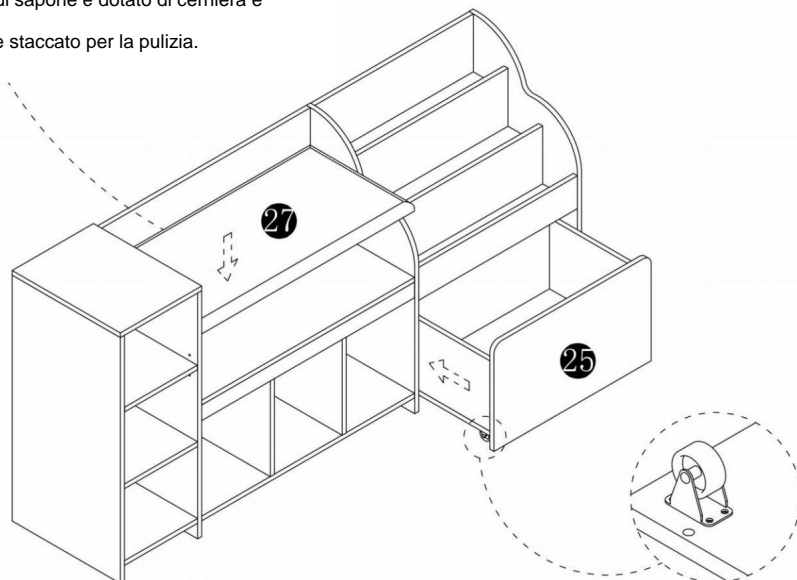

## PARAMETRO DEL PRODOTTO

<b>Modello</b>	C250224D-01
<b>Portante statico</b>	MAX 350 libbre
<b>Colore</b>	Bianco
<b>Dimensioni del prodotto</b>	1700×400×800mm

**Produttore:** Guangzhou Dingxin Office Furniture Co., LTD **Indirizzo del produttore:** n. 1700, Renhe Road, città di Aotou, distretto di Conghua, Guangzhou, provincia del Guangdong **Importato in AUS:** SIHAO PTY LTD. 1 ROKEVA STREETEASTWOOD NSW 2122 Australia

**Importato negli USA:** Sanven Technology Ltd. Suite 250, 9166 Anaheim Place, Rancho Cucamonga, CA 91730



YH CONSULTING LIMITED. C/O YH Consulting Limited  
Ufficio 147, Centurion House, London Road, Staines-upon-Thames, Surrey, TW18 4AX



E-CrossStu GmbH  
Mainzer Landstr.69,  
60329 Francoforte sul Meno.



# VEVOR

**Affordable. Reliable. Home Improvement.**

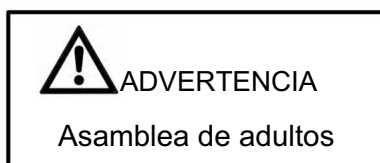



BANCOS DE ALMACENAMIENTO PARA NIÑOS

MODELO: C250224D-01

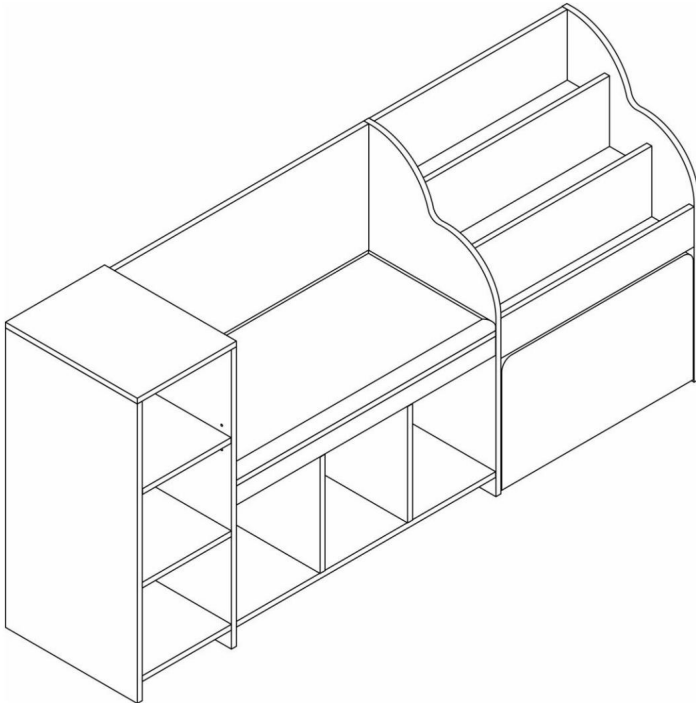
MODELO: C250224D-01



Estas son las instrucciones originales; lea atentamente todas las instrucciones del manual antes de utilizarlo. VEVOR se reserva el derecho de interpretar este manual de usuario. La apariencia del producto dependerá del producto que haya recibido. Le rogamos que nos disculpe si no le informamos de nuevo si hay actualizaciones tecnológicas o de software en nuestro producto.

	<p>Advertencia: Para reducir el riesgo de lesiones, el usuario debe leer Lea atentamente el manual de instrucciones.</p> <p>Nota: ¡Requiere ensamblaje por parte de un adulto!</p>
	<p>Compliance es una certificación de seguridad CE.</p>
<p><b>Siglos</b></p>	<p>3 años +</p>

## INSTRUCCIONES DE SEGURIDAD

### ADVERTENCIA:

Lea este material antes de usar este producto. De lo contrario, podría...  
provocar lesiones graves.

### Precauciones de montaje

1. Ensamble únicamente según estas instrucciones. Montaje incorrecto.  
Puede crear peligros.
2. Mantenga el área de reunión limpia y bien iluminada.
3. Las capacidades del producto se aplican a productos ensamblados correctamente y completamente.  
Sólo productos.
4. Montar sobre una superficie plana, nivelada, dura y lisa capaz de soportar cargas de forma segura.  
Apoyando los bancos de almacenamiento para niños.
5. Para obtener información adicional sobre las piezas enumeradas a continuación,  
páginas, consulte el diagrama de montaje de este manual. Desenvuelva  
y separe todas las piezas en un área de trabajo limpia.

### Tome precauciones

1. **NO SE SIENTA NI SE PARE SOBRE ESTE ARTÍCULO.**
2. Este producto no es un juguete. No permita que los niños jueguen con él ni cerca de él.  
artículo.
3. No exceda las capacidades de peso especificadas.
4. Úselo solo sobre una superficie plana, nivelada, dura y lisa que pueda  
Admite bancos de almacenamiento para niños completamente cargados.
5. Úselo únicamente según lo previsto.
6. Inspeccione antes de cada uso; no lo utilice si las piezas están sueltas o dañadas.

**GUARDE ESTE MANUAL**

## INSTALACIÓN DE LEVAS Y PASADORES

Enrosque el pasador en el orificio. Para ajustar las levas correctamente, asegúrese de que la flecha de la leva esté orientada hacia el orificio del pasador que bloquea. Bloquee la leva girando la cabeza de la leva con un destornillador hasta que esté apretada. No utilice un aparato eléctrico. destornillador para montar la unidad.

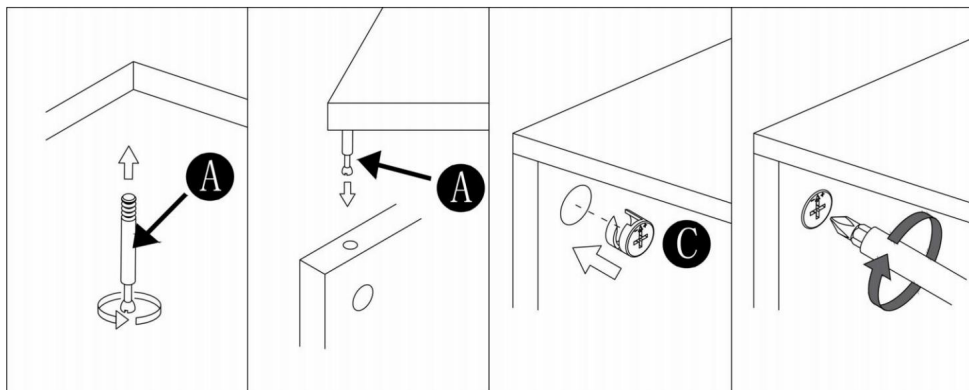



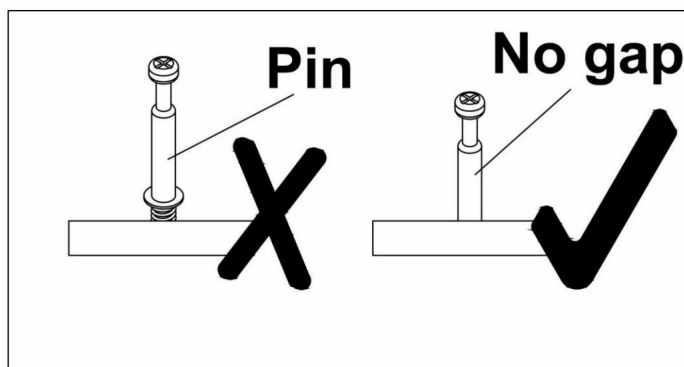



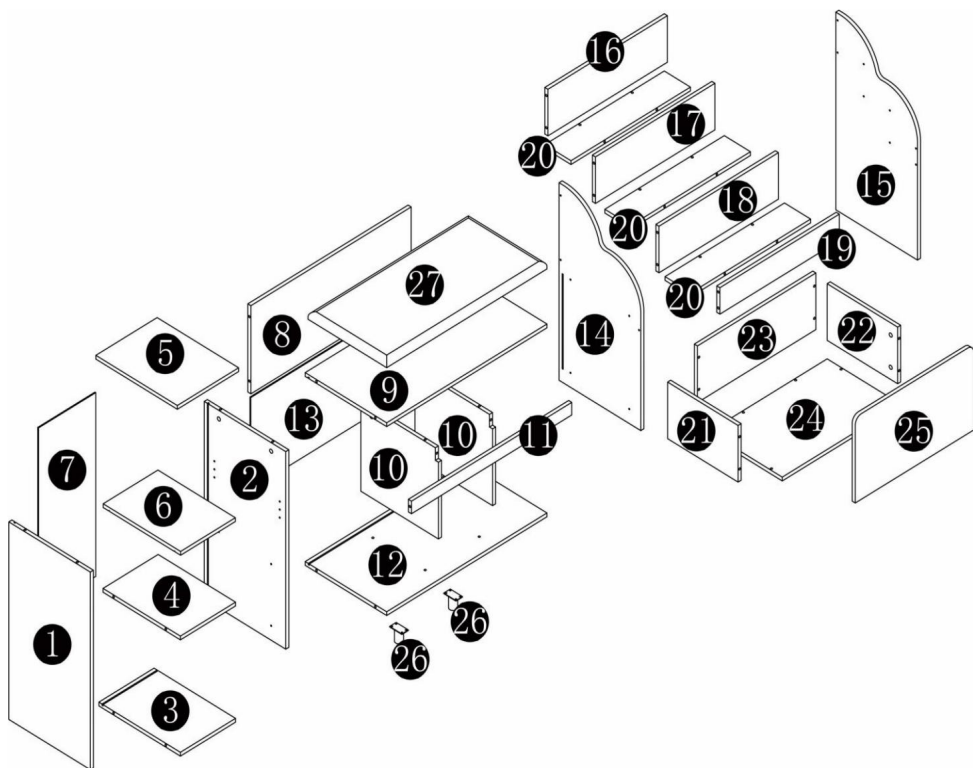



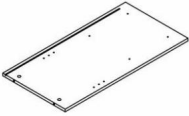
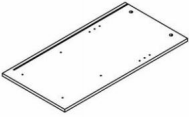

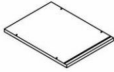

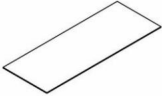
Lea cada paso detenidamente antes de comenzar. Es fundamental realizar cada paso de las instrucciones en el orden correcto. Si no se siguen en secuencia, podrían surgir dificultades de montaje.

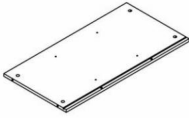

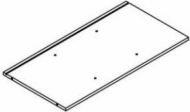
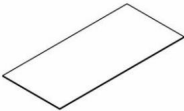

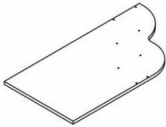

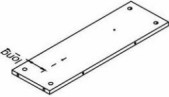
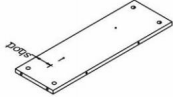
LISTA DE PIEZAS Y HERRAMIENTAS

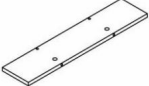



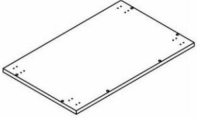

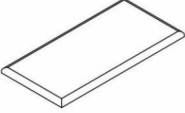





# Lista de hardware

 <p><b>1</b> 1pc</p>	 <p><b>2</b> 1pc</p>	 <p><b>3</b> 1pc</p>	 <p><b>4</b> 1pc</p>
 <p><b>5</b> 1pc</p>	 <p><b>6</b> 1pc</p>	 <p><b>7</b> 1pc</p>	 <p><b>8</b> 1pc</p>
 <p><b>9</b> 1pc</p>	 <p><b>10</b> 2pcs</p>	 <p><b>11</b> 1pc</p>	 <p><b>12</b> 1pc</p>
 <p><b>13</b> 1pc</p>	 <p><b>14</b> 1pc</p>	 <p><b>15</b> 1pc</p>	 <p><b>16</b> 1pc</p>
 <p><b>17</b> 1pc</p>	 <p><b>18</b> 1pc</p>	 <p><b>19</b> 1pc</p>	 <p><b>20</b> 3pcs</p>

 <b>21</b> 1pc	 <b>22</b> 1pc	 <b>23</b> 1pc	 <b>24</b> 1pc
 <b>25</b> 1pc	 <b>26</b> 2pcs	 <b>27</b> 1pc	

Lista de piezas

 <b>A</b> 58pcs	 <b>B</b> M7X50MM 22pcs	 <b>C</b> 58pcs	 <b>P</b> M3. 5X12MM 36pcs	 <b>Q</b> 4pcs
 <b>U</b> 12pcs	 <b>Y</b> 1.5" 4pcs	 <b>Z</b> φ20 58pcs		

## PASO DE MONTAJE

1

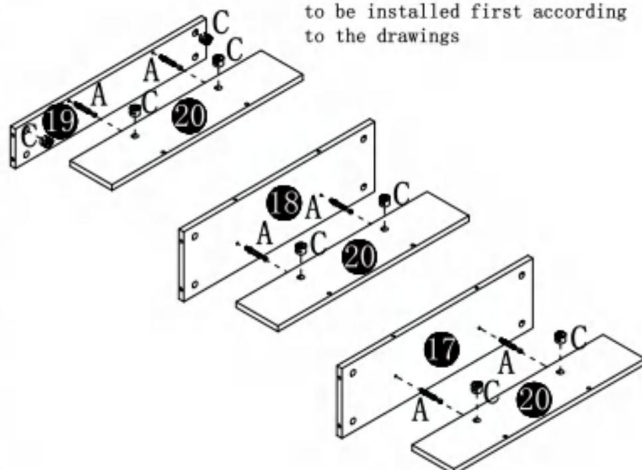
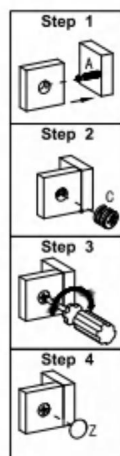

Please note that for Board 19, two accessories numbered C need to be installed first according to the drawings

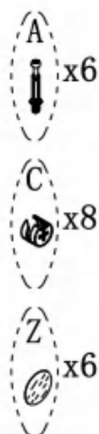

2

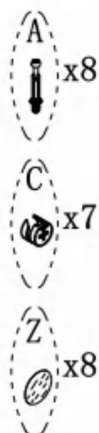
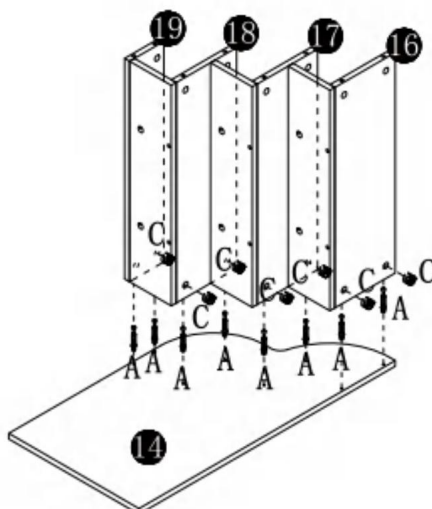
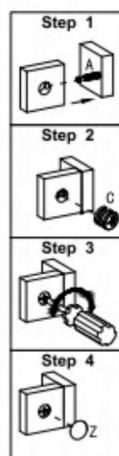

3

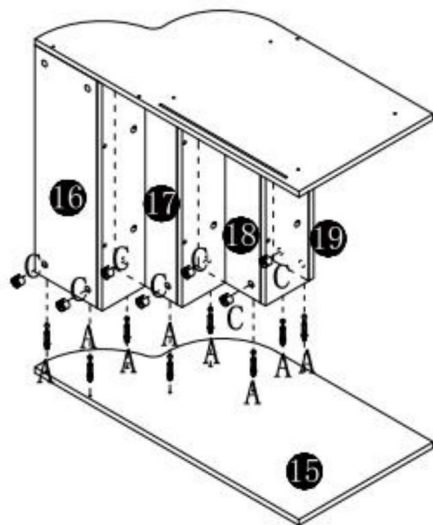
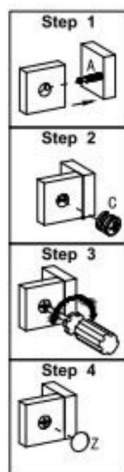

4

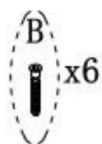
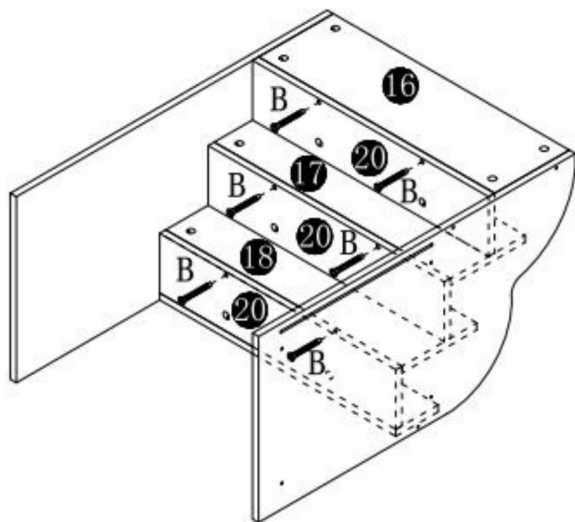

5

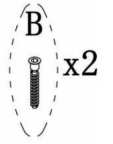
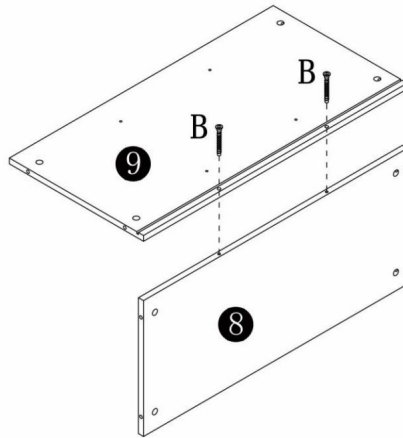

6

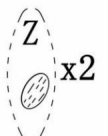
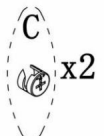
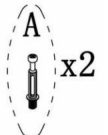
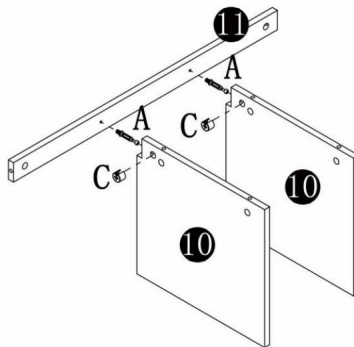
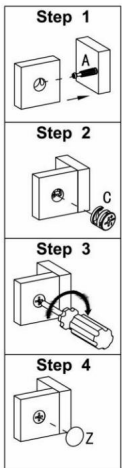

7

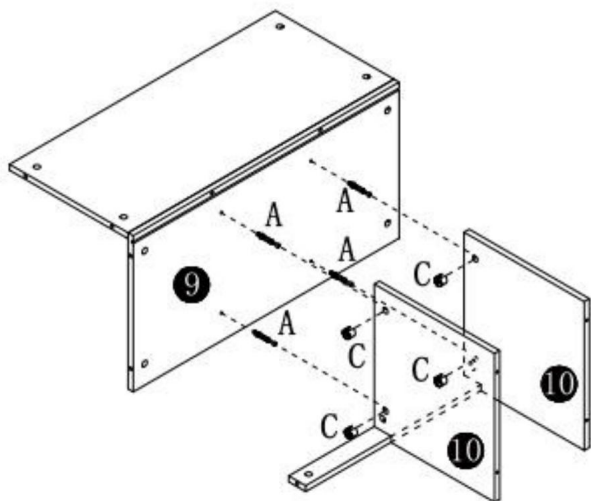
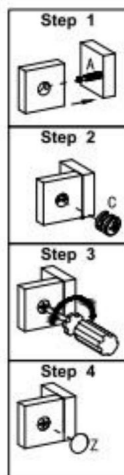

8

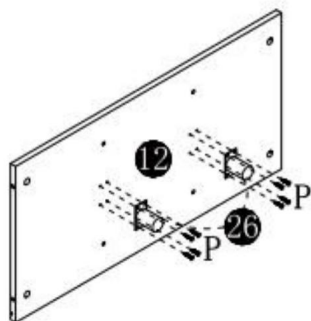
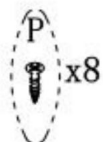

9

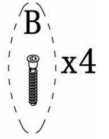
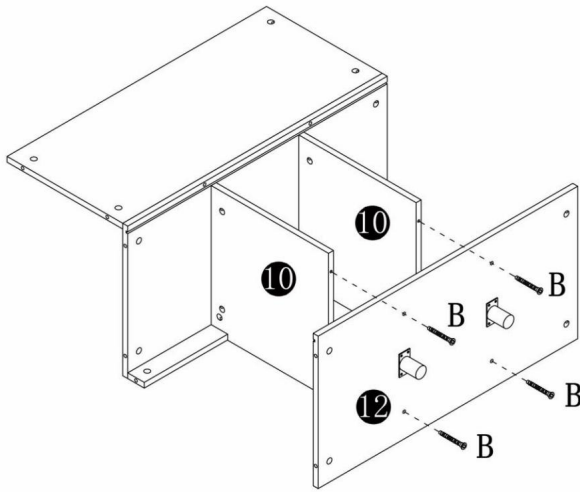

10

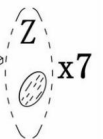
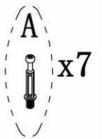
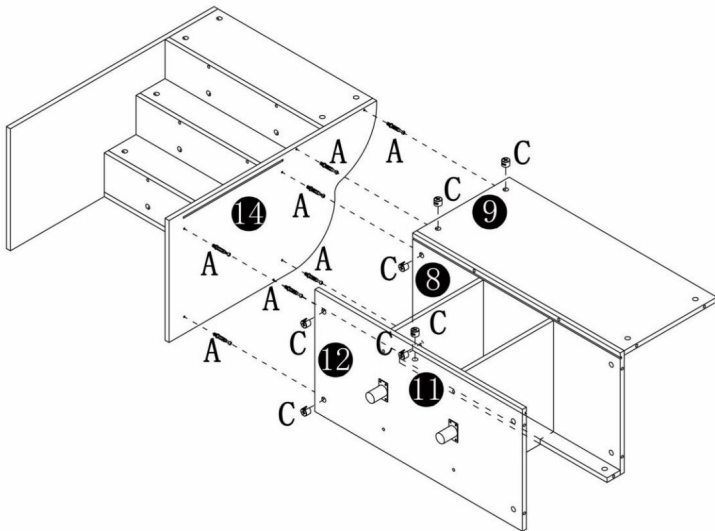
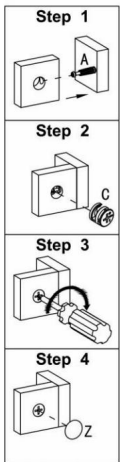

11

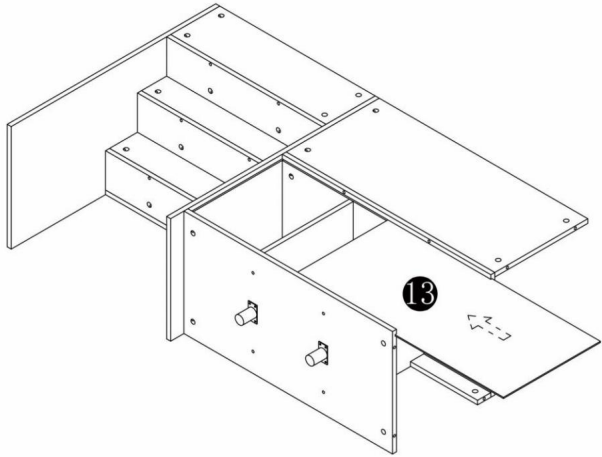

12

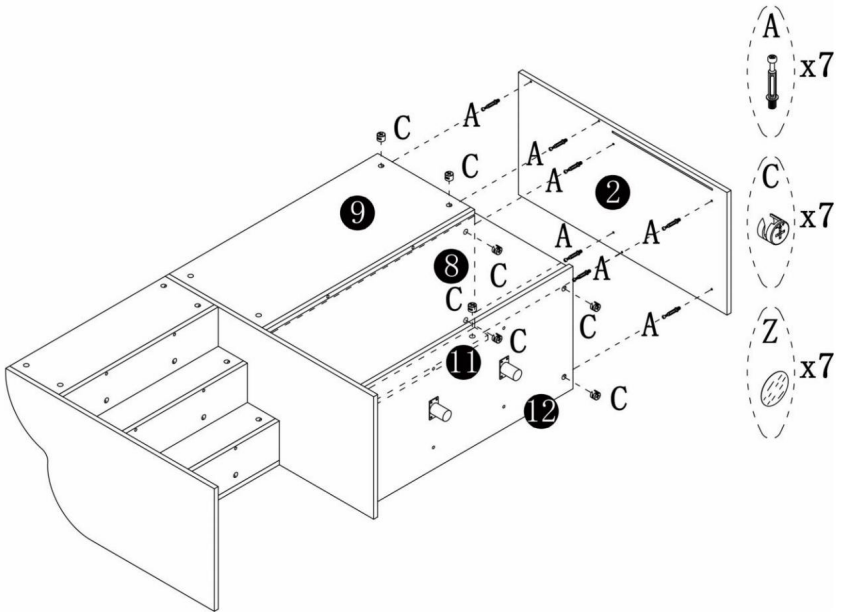
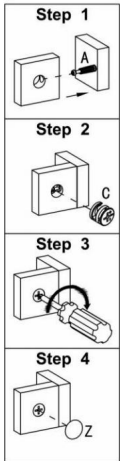

13

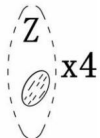
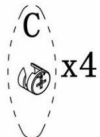
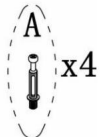
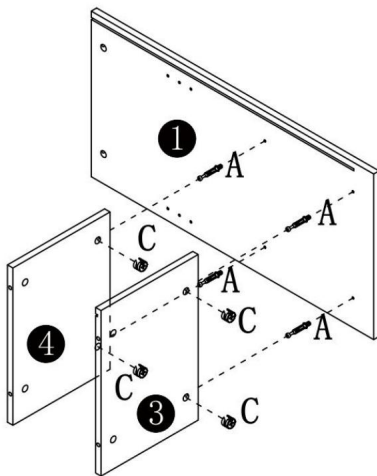
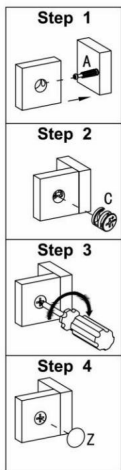

14

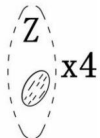
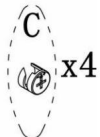
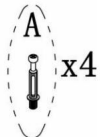
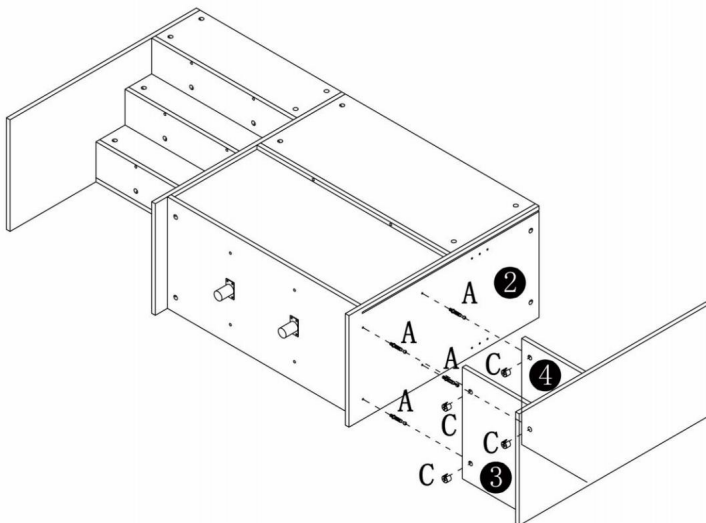
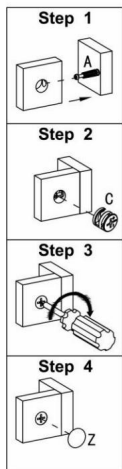

15

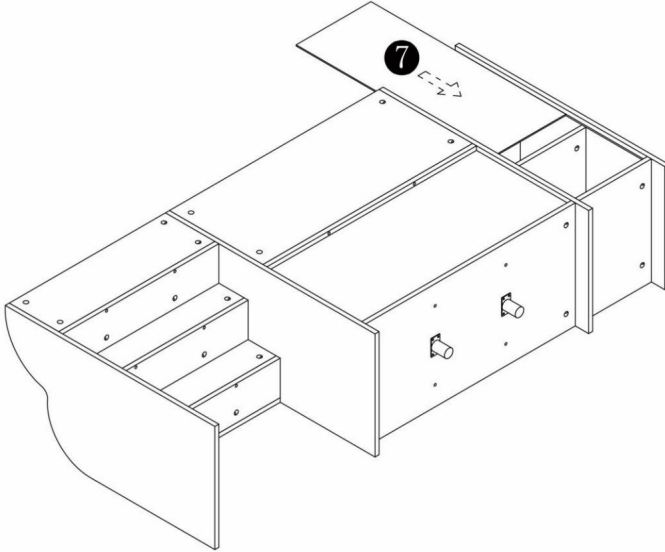

16

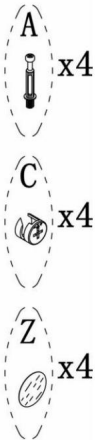
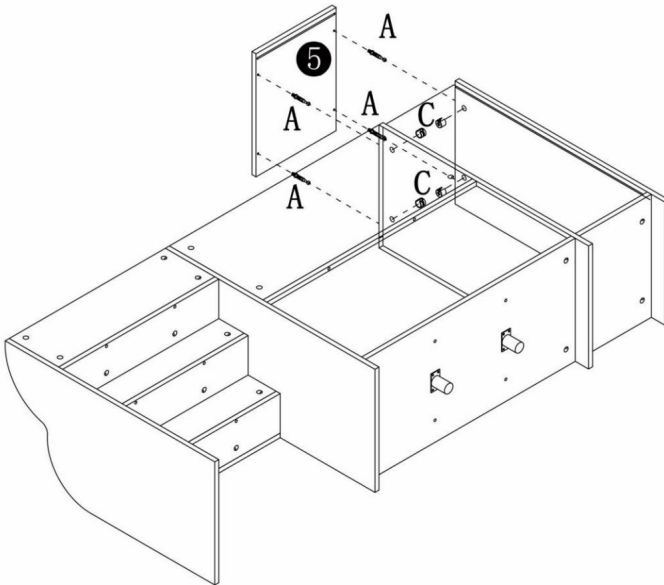
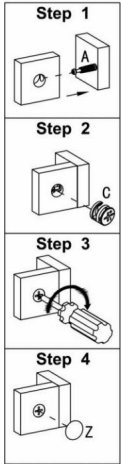

17

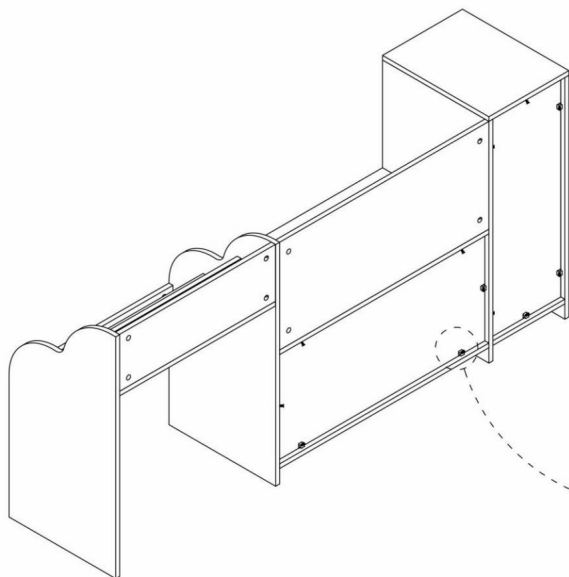

U  
x12

P  
x12

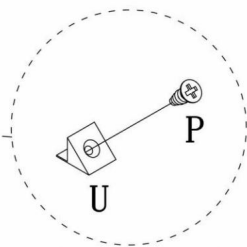

18

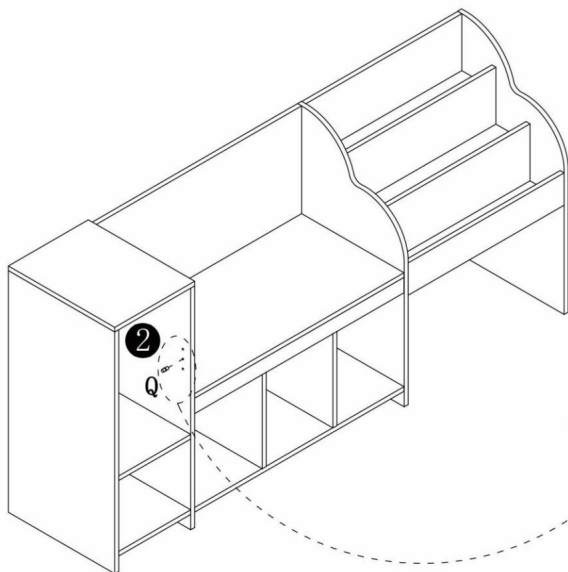

Q  
x4

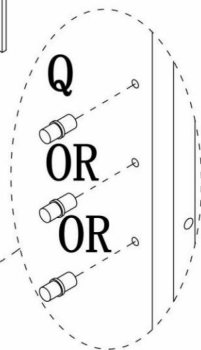

19

El estante móvil puede ser colocado en tres posiciones.

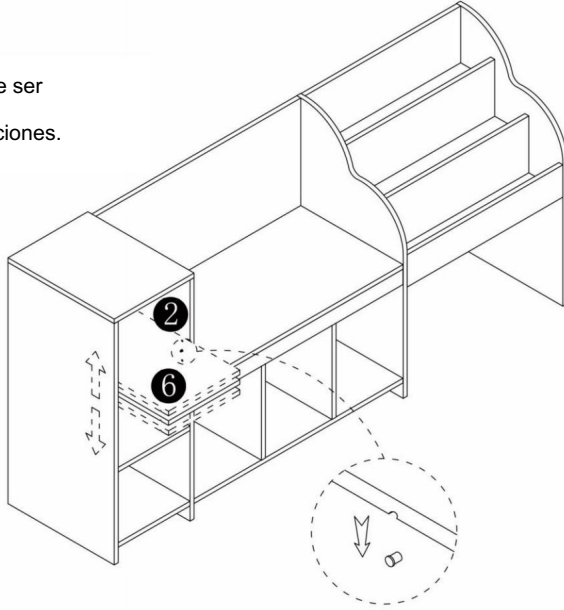

20

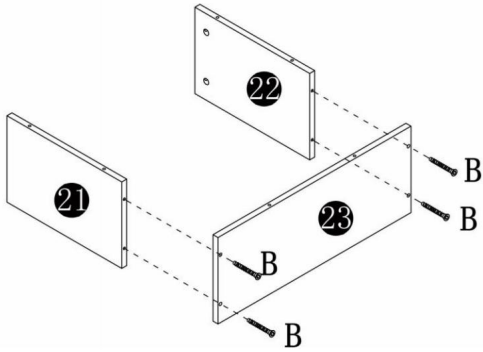
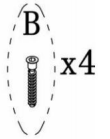

# 21

Las ruedas direccionales solo pueden moverse hacia adelante y hacia atrás, mientras que las ruedas universales no pueden girar 360 grados.

- P x16
- Y x4

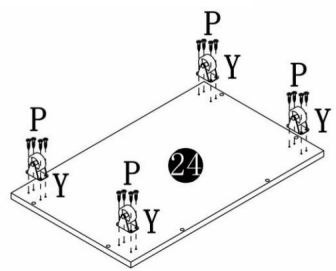

# 22

- B x6

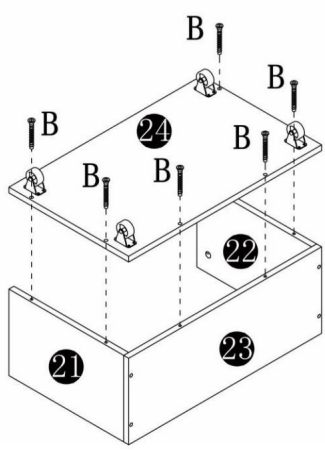

23

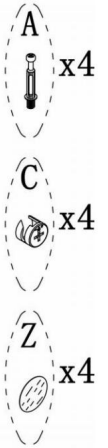
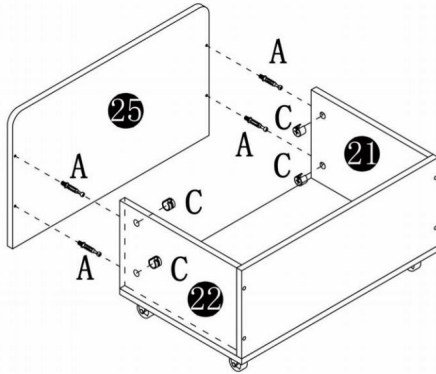
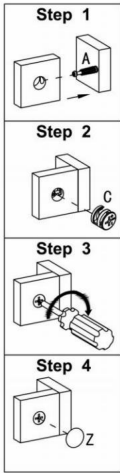

24

El cojín de jabón tiene cremallera y es desmontable para limpiarlo.

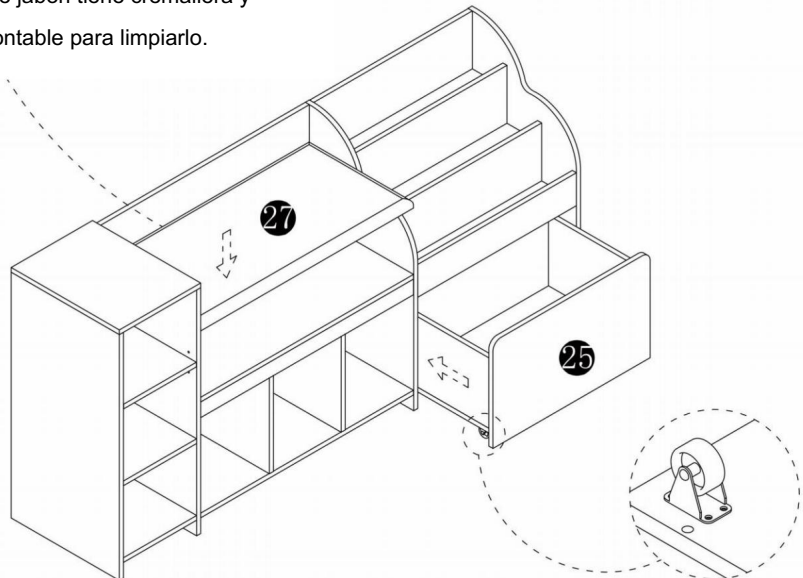

## PARÁMETRO DEL PRODUCTO

Modelo	C250224D-01
Soporte de carga estática	MÁXIMO 350 libras
Color	Blanco
Tamaño del producto	1700×400×800 mm

Fabricante: Guangzhou Dingxin Office Furniture Co., LTD Dirección del fabricante: No. 1700, Renhe Road, Aotou Town, Conghua District, Guangzhou, Guangdong Province Importado a AUS: SIHAO PTY LTD. 1  
 ROKEVA STREETEASTWOOD NSW 2122 Australia

Importado a EE. UU.: Sanven Technology Ltd. Suite 250, 9166 Anaheim Place, Rancho Cucamonga, CA 91730

Representante del Reino Unido	
-------------------------------	--

YH CONSULTING LIMITED. A/C YH Consulting Limited  
 Oficina 147, Centurion House, London Road, Staines-upon-Thames, Surrey, TW18 4AX

Representante de la CE	
------------------------	--

E-CrossStu GmbH  
 Mainzer Landstr.69,  
 60329 Fráncfort del Meno.



# VEVOR

**Affordable. Reliable. Home Improvement.**



ŁAWKI Z PRZECHOWYWANIEM DLA DZIECI

MODEL: C250224D-01

# VEVOR

Affordable. Reliable. Home Improvement.



PRZECHOWYWANIE DLA DZIECI

ŁAWKI

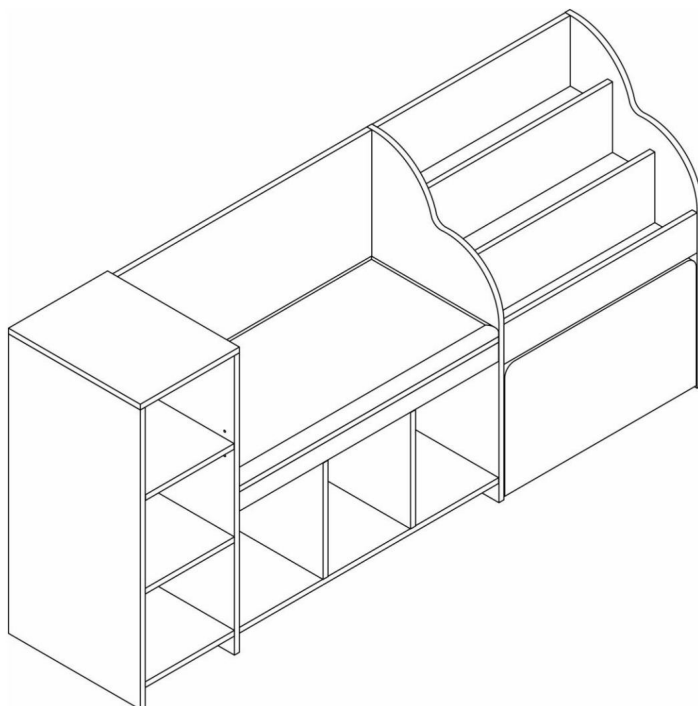
MODEL: C250224D-01



To jest oryginalna instrukcja obsługi. Przed użyciem prosimy o dokładne zapoznanie się z treścią instrukcji. Firma VEVOR zastrzega sobie prawo do jednoznacznej interpretacji niniejszej instrukcji obsługi. Wygląd produktu zależy od stanu, w jakim go otrzymali Państwo. Prosimy o wyrozumiałość, ale nie będziemy Państwa ponownie informować o aktualizacjach technologicznych lub oprogramowania naszego produktu.

	<p>Ostrzeżenie – Aby zmniejszyć ryzyko obrażeń, użytkownik musi przeczytać uważnie przeczytaj instrukcję obsługi.</p> <p>Uwaga: Wymagany montaż przez osobę dorosłą!</p>
	<p>Zgodność oznacza certyfikat bezpieczeństwa CE.</p>
<p>Wieczność</p>	<p>3 lata +</p>

## INSTRUKCJE BEZPIECZEŃSTWA

### OSTRZEŻENIE:

Przed użyciem produktu należy zapoznać się z treścią niniejszego dokumentu. Niezastosowanie się do tego zalecenia może spowodować poważne obrażenia.

### Środki ostrożności podczas montażu

1. Montaż należy wykonywać wyłącznie zgodnie z niniejszą instrukcją. Nieprawidłowy montaż może stwarzać zagrożenie.
2. Utrzymuj miejsce zgromadzenia w czystości i dobrym oświetleniu.
3. Możliwość produktu dotyczą produktu prawidłowo i całkowicie zmontowanego tylko produkty.
4. Montaż należy wykonać na płaskiej, równej, twardej i gładkiej powierzchni, która będzie bezpieczna. wspieranie ławek dziecięcych ze schowkami.
5. Aby uzyskać dodatkowe informacje dotyczące części wymienionych poniżej stron, zapoznaj się ze schematem montażu w niniejszej instrukcji. Rozpakuj i oddzielić wszystkie części w czystym miejscu pracy.

### Zachowaj środki ostrożności

1. **NIE WOLNO SIEDZIEĆ ANI STAWAĆ NA TYM PRZEDMIOCIE.**
2. Ten produkt nie jest zabawką. Nie pozwalaj dzieciom bawić się nim ani przebywać w jego pobliżu. przedmiot.
3. Nie przekraczać dopuszczalnego obciążenia.
4. Używaj wyłącznie na płaskiej, równej, twardej i gładkiej powierzchni, która może być bezpiecznie używana. obsługuje w pełni załadowane ławki dziecięce ze schowkami.
5. Używać wyłącznie zgodnie z przeznaczeniem.
6. Przed każdym użyciem należy przeprowadzić kontrolę. Nie należy używać produktu, jeśli jakieś części są luźne lub uszkodzone.

ZAPISZ TĘ INSTRUKCJĘ

## MONTAŻ KRZYWEK I SWORZNI

Wkręć sworznię w otwór. Aby prawidłowo ustawić krzywkę, upewnij się, że strzałka na krzywce jest skierowana w stronę otworu blokującego sworzni. Zablokuj krzywkę, obracając głowicę krzywki śrubokrętem, aż będzie dokręcona. Nie używaj elektrycznego narzędzia. Śrubokręt do montażu urządzenia.

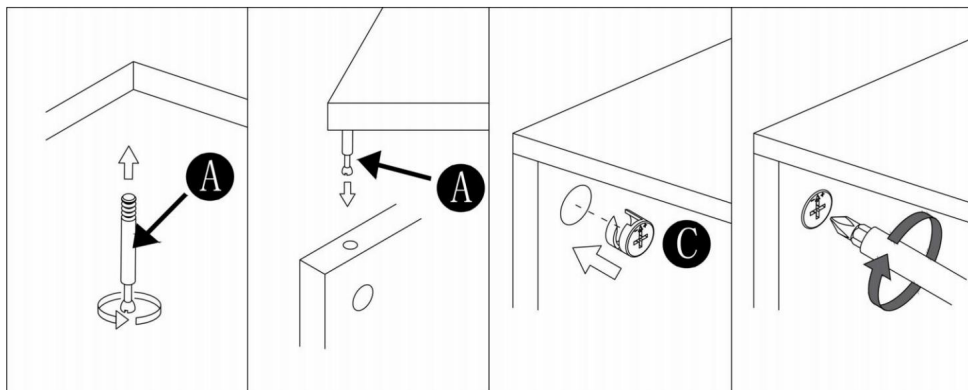



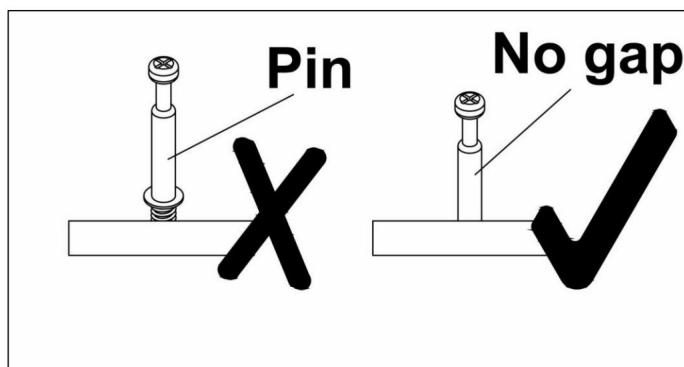



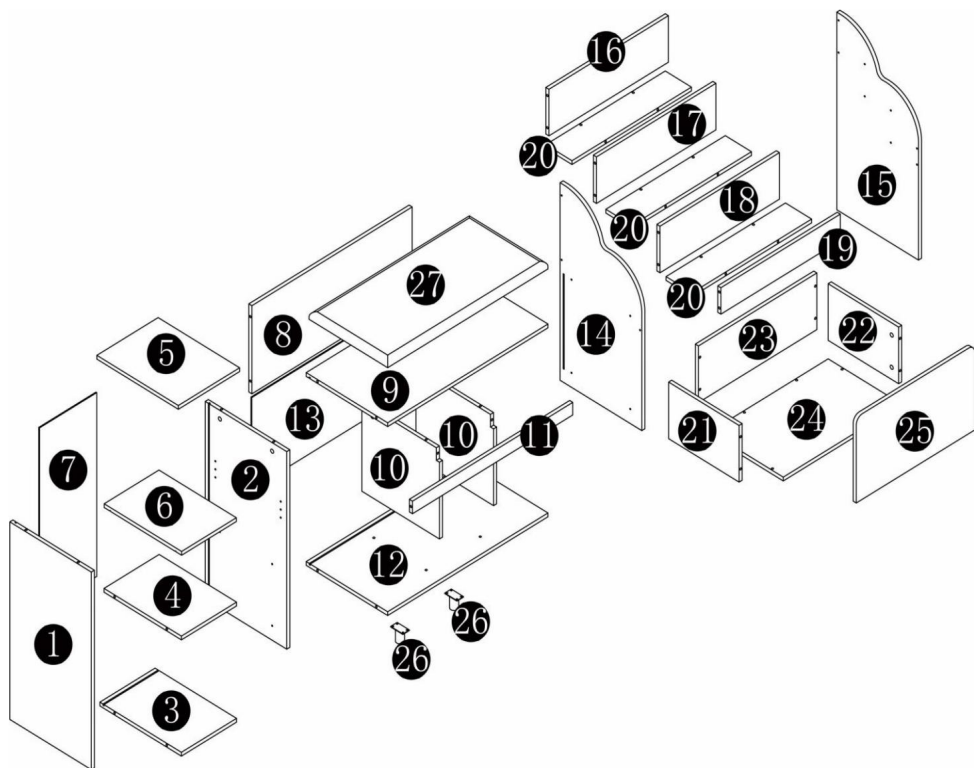



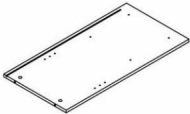
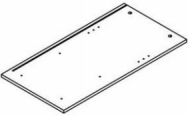

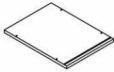
Przed rozpoczęciem pracy należy uważnie przeczytać każdy krok. Bardzo ważne jest, aby każdy krok instrukcji został wykonany we właściwej kolejności. Niewykonanie tych kroków w odpowiedniej kolejności może spowodować trudności w montażu.

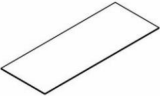



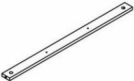
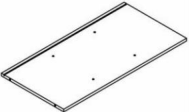
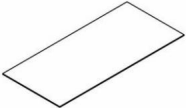
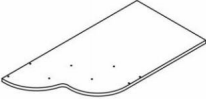
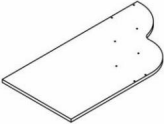

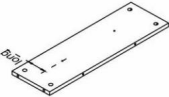
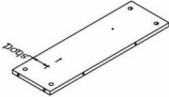

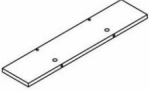
LISTA CZĘŚCI I SPRZĘTU







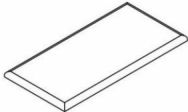





# Lista sprzętu

 <b>1</b> 1pc	 <b>2</b> 1pc	 <b>3</b> 1pc	 <b>4</b> 1pc
 <b>5</b> 1pc	 <b>6</b> 1pc	 <b>7</b> 1pc	 <b>8</b> 1pc
 <b>9</b> 1pc	 <b>10</b> 2pcs	 <b>11</b> 1pc	 <b>12</b> 1pc
 <b>13</b> 1pc	 <b>14</b> 1pc	 <b>15</b> 1pc	 <b>16</b> 1pc
 <b>17</b> 1pc	 <b>18</b> 1pc	 <b>19</b> 1pc	 <b>20</b> 3pcs

 <b>21</b> 1pc	 <b>22</b> 1pc	 <b>23</b> 1pc	 <b>24</b> 1pc
 <b>25</b> 1pc	 <b>26</b> 2pcs	 <b>27</b> 1pc	

## Lista części

 <b>A</b> 58pcs	 <b>B</b> 22pcs	 <b>C</b> 58pcs	 <b>P</b> 36pcs	 <b>Q</b> 4pcs
 <b>U</b> 12pcs	 <b>Y</b> 4pcs	 <b>Z</b> 58pcs		

# KROK MONTAŽU

1

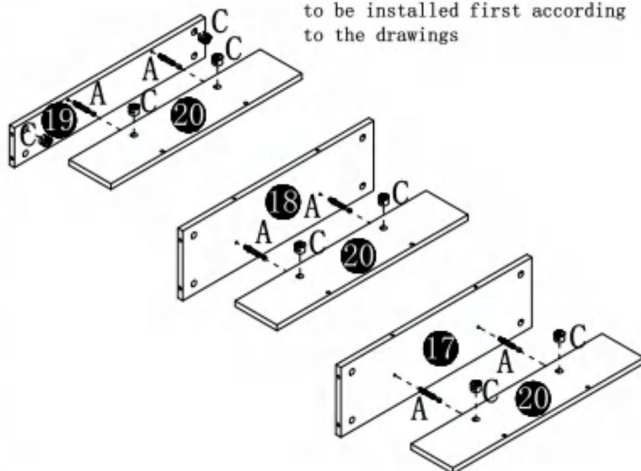
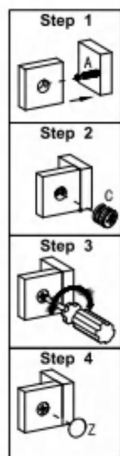

Please note that for Board 19, two accessories numbered C need to be installed first according to the drawings

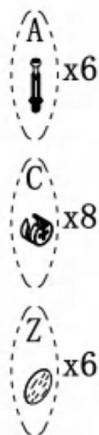

2

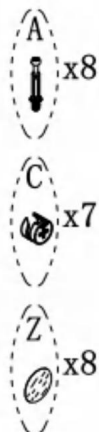
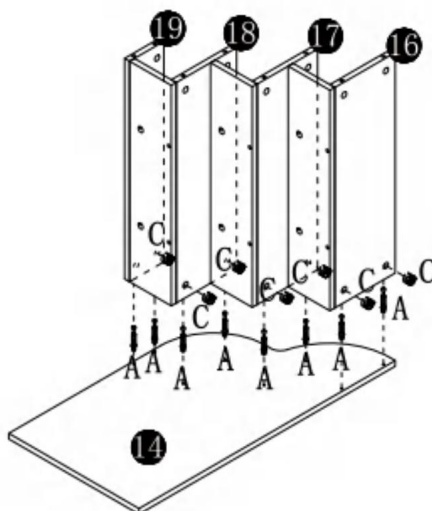
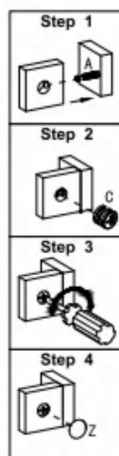

3

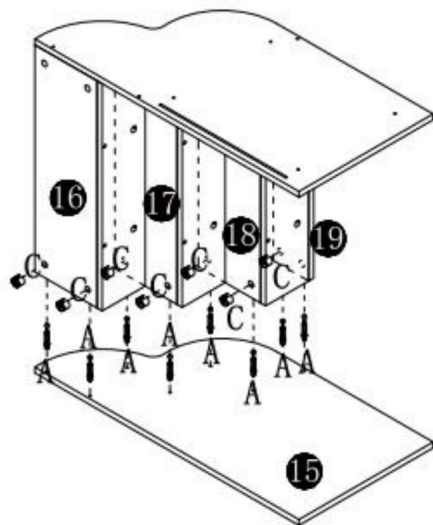
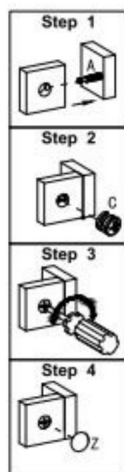

4

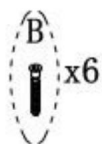
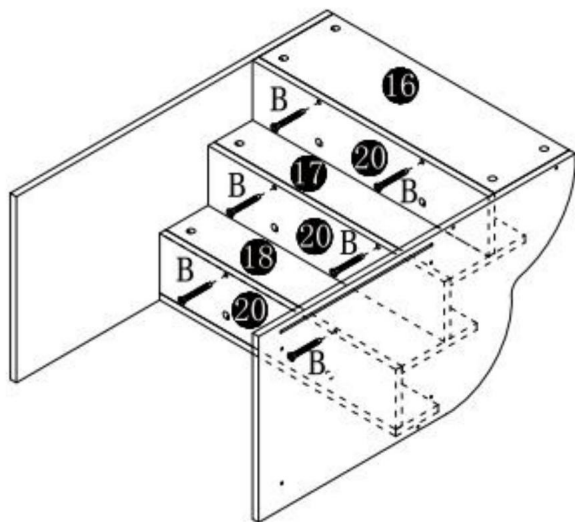

5

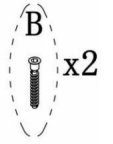
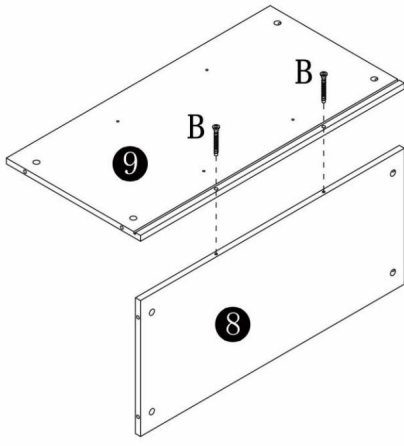

6

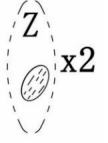
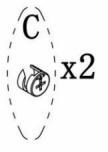
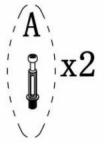
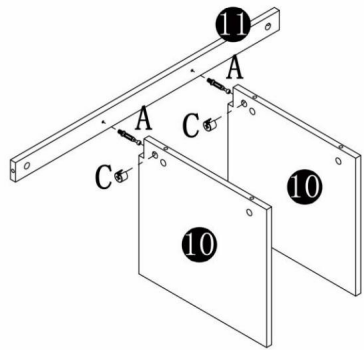
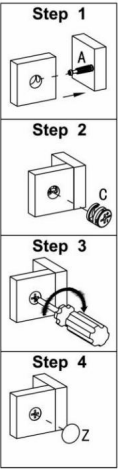

7

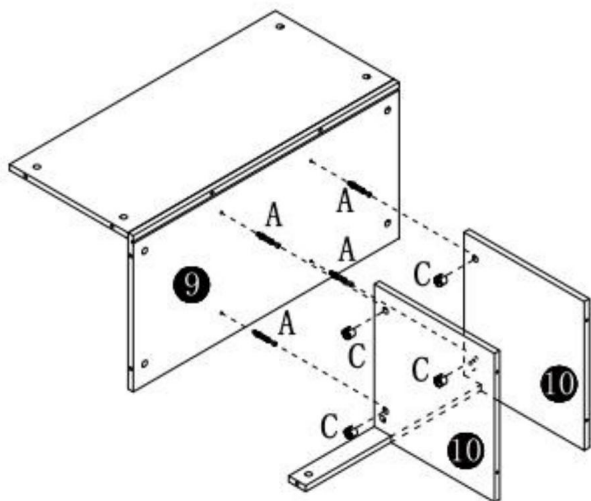
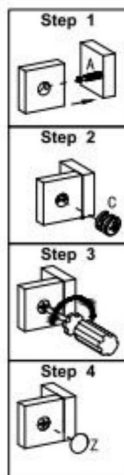

8

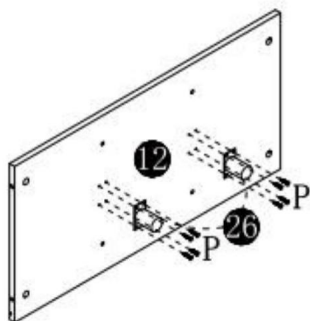
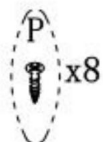

9

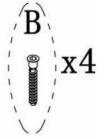
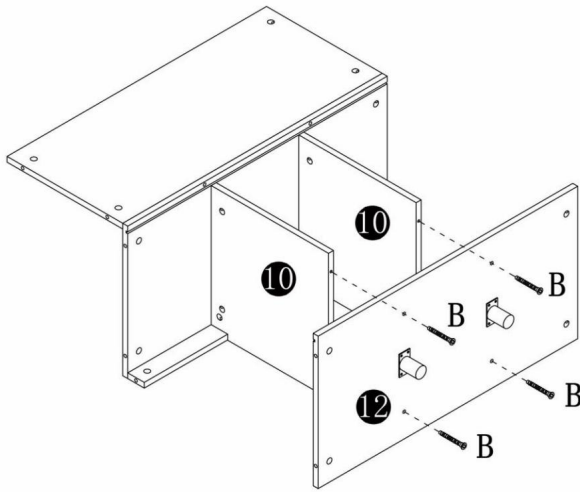

10

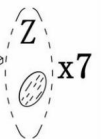
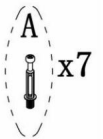
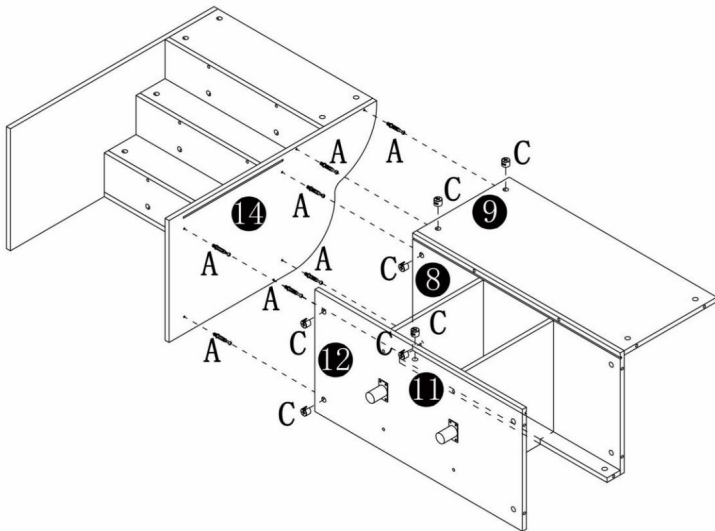
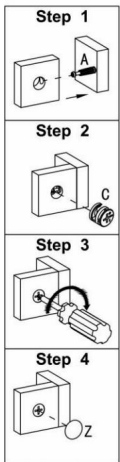

11

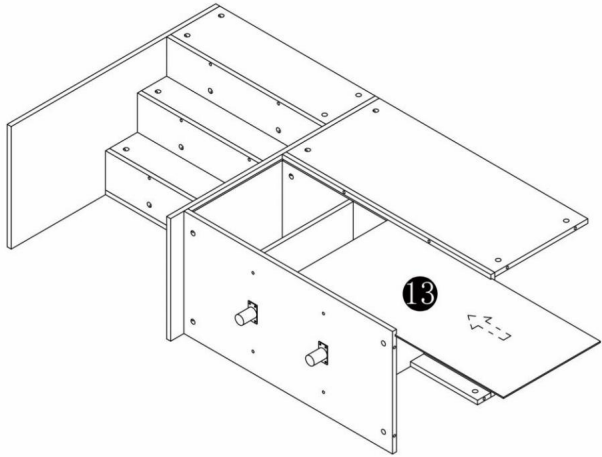

12

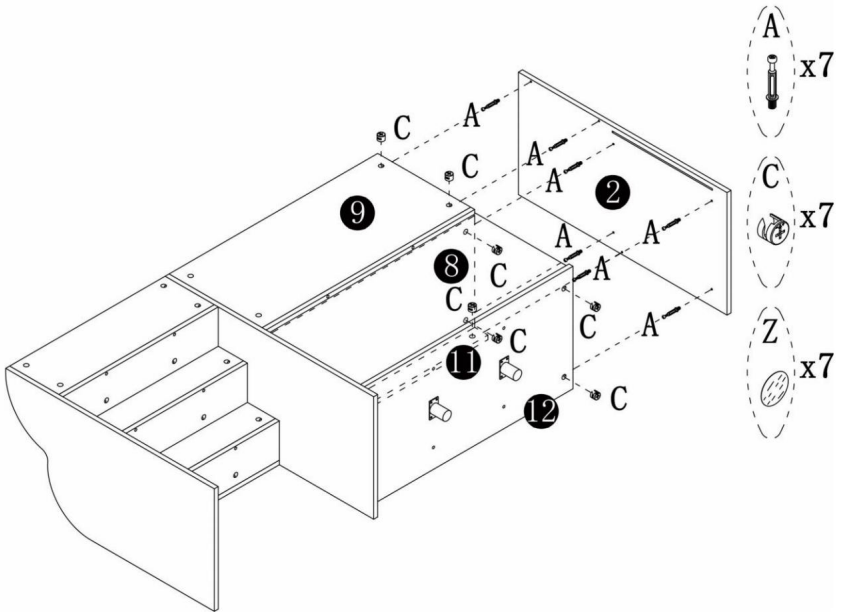
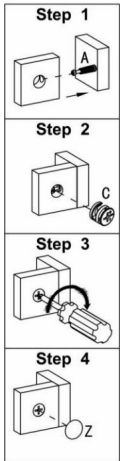

13

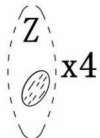
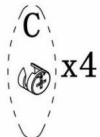
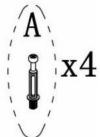
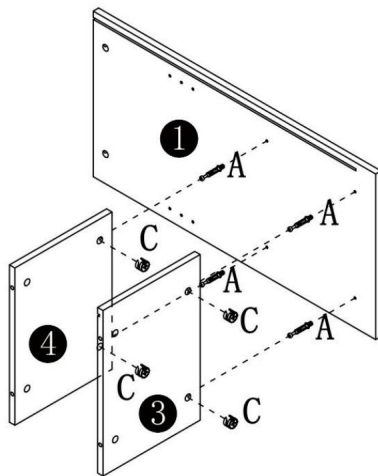
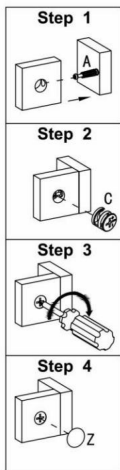

14

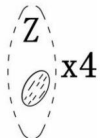
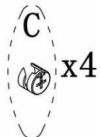
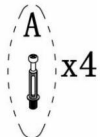
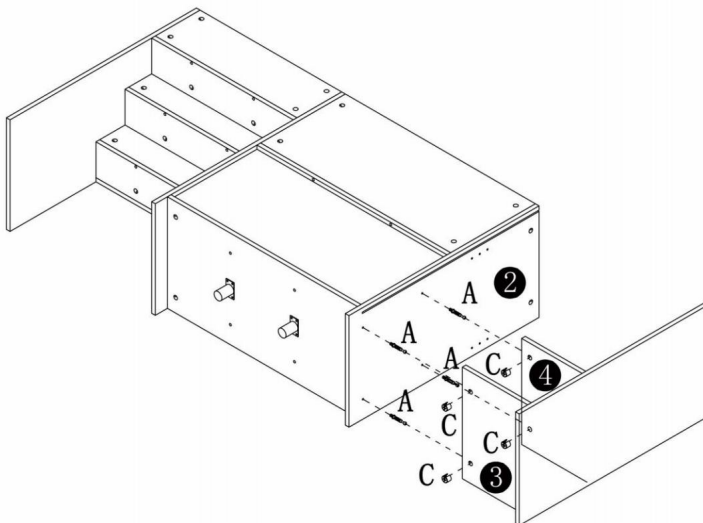
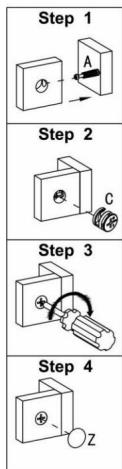

15

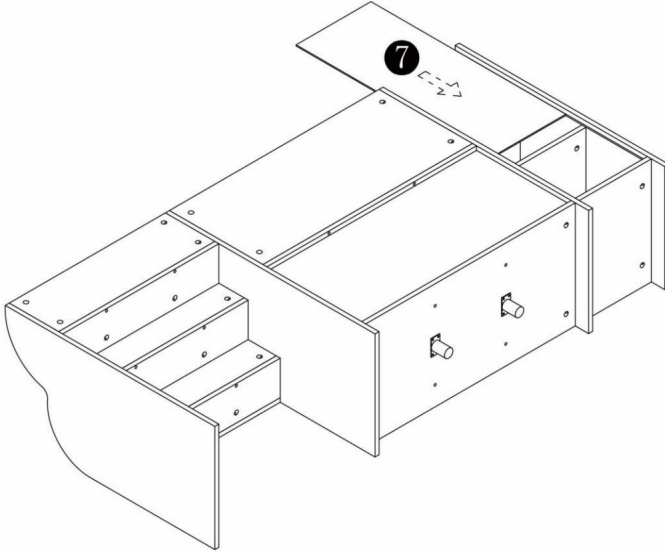

16

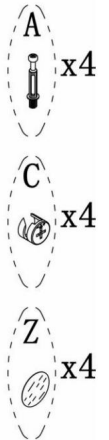
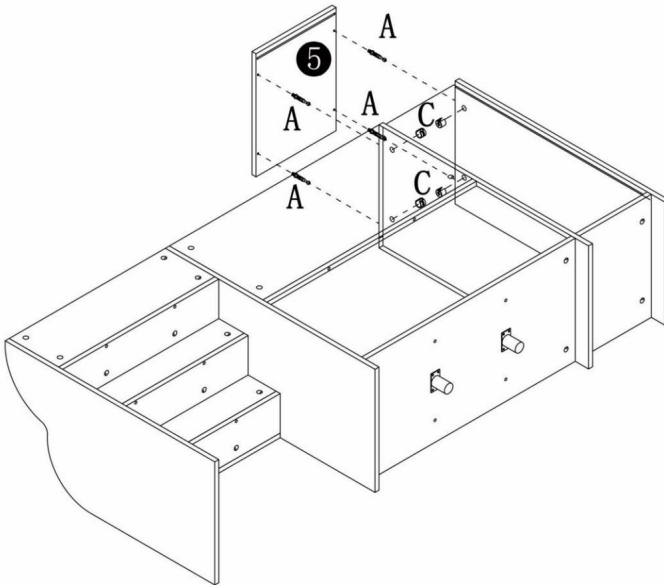
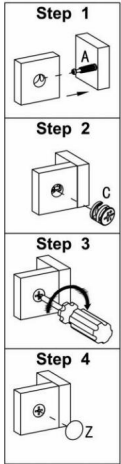

17

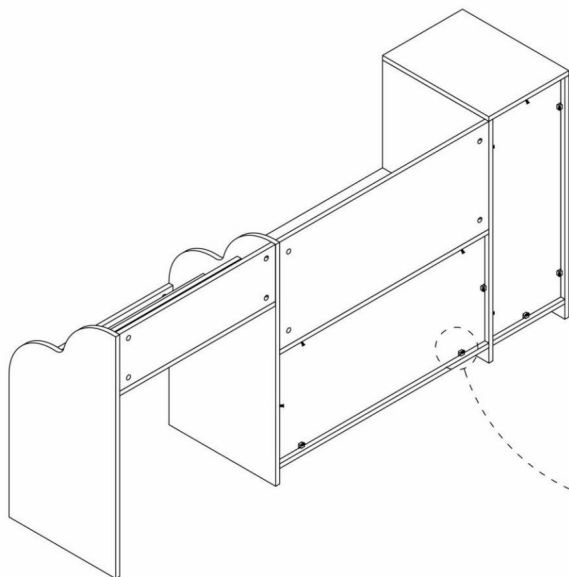

U  
x12

P  
x12

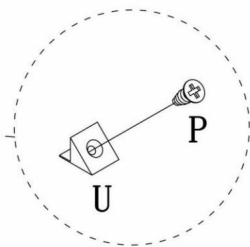

18

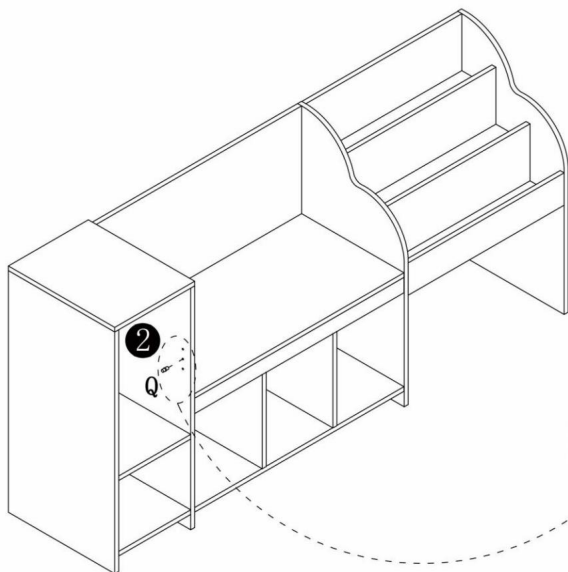

Q  
x4

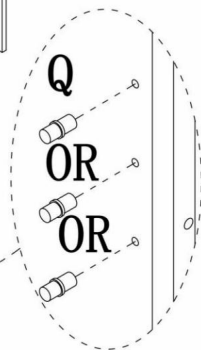

19

Ruchomą półkę można  
umieścić w trzech pozycjach.

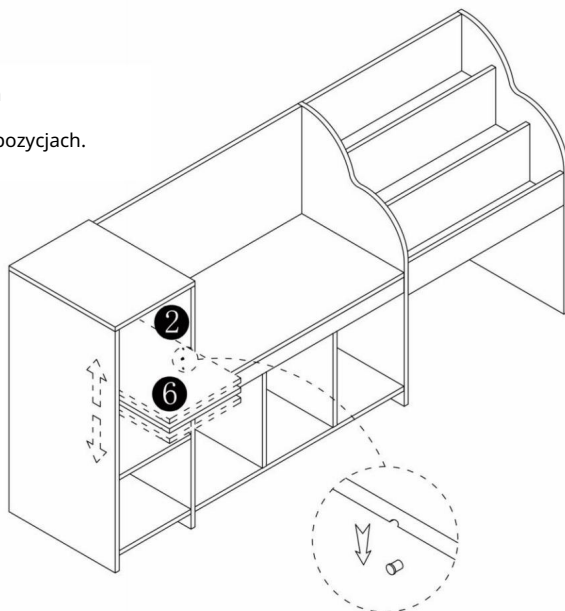

20

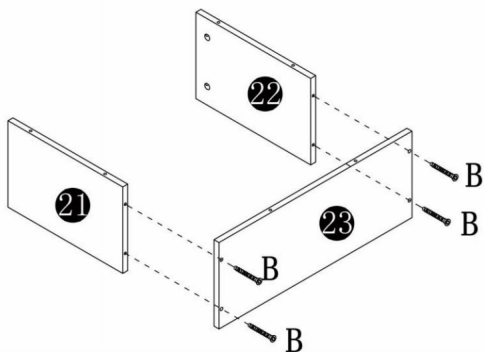
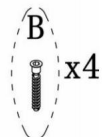

21

Koła kierunkowe mogą poruszać się tylko do przodu i do tyłu, natomiast koła nieuniwersalne nie mogą obracać się o 360 stopni.

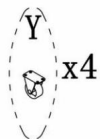
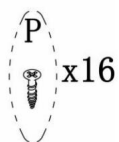
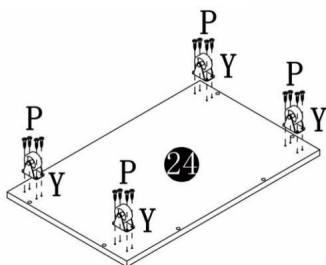

22

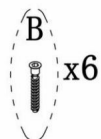
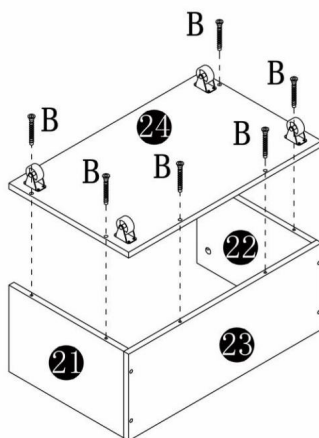

# 23

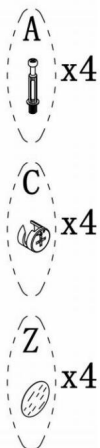
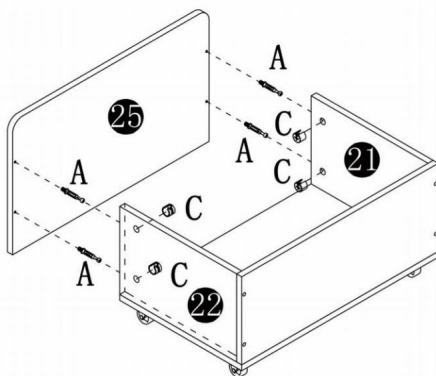
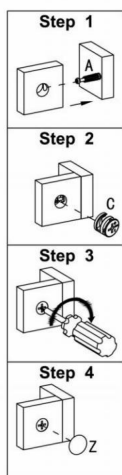

# 24

Poduszka sojowa jest zapinana na zamek i można ją zdjąć w celu czyszczenia.

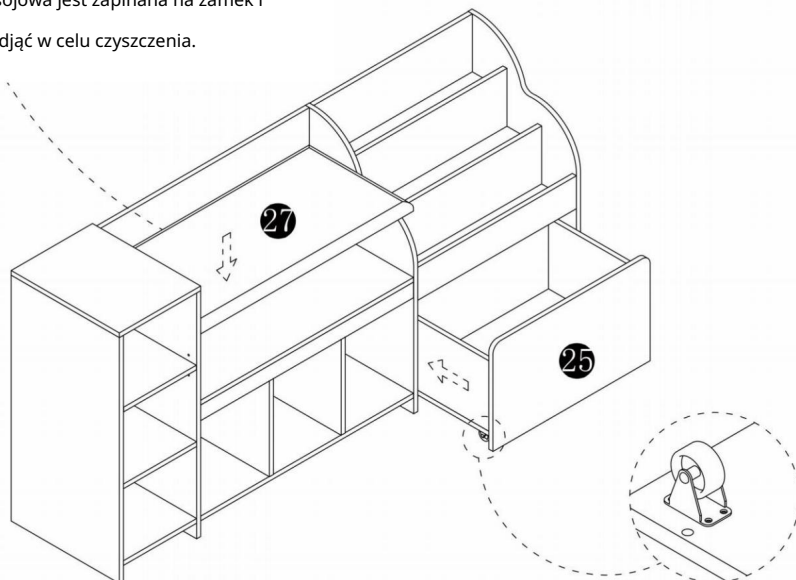

## PARAMETR PRODUKTU

Model	C250224D-01
Nośność statyczna	MAKSYMALNIE 350 funtów
Kolor	Biały
Rozmiar produktu	1700×400×800 mm

Producent: Guangzhou Dingxin Office Furniture Co., LTD Adres producenta:  
No. 1700, Renhe Road, Aotou Town, Conghua District, Guangzhou, prowincja Guangdong  
Importer do Australii: SIHAO PTY LTD. 1 ROKEVA  
STREETEASTWOOD NSW 2122 Australia

Importowane do USA: Sanven Technology Ltd. Suite 250, 9166 Anaheim Place, Rancho  
Cucamonga, CA 91730

REP WIELKIEJ BRYTANII
-----------------------

YH CONSULTING LIMITED. C/O YH Consulting Limited  
Biuro 147, Centurion House, London Road, Staines-  
upon-Thames, Surrey, TW18 4AX

Przedstawiciel WE
-------------------

E-CrossStu GmbH  
Mainzer Landstr.69,  
60329 Frankfurt nad Menem.



# VEVOR

**Affordable. Reliable. Home Improvement.**

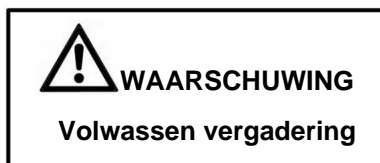



**KINDEROPBERGBANKEN**

**MODEL: C250224D-01**

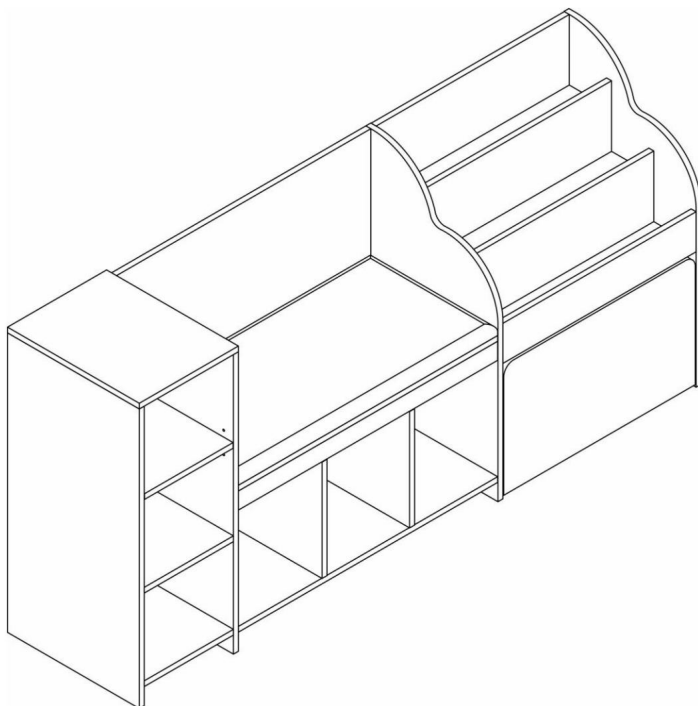
MODEL: C250224D-01



Dit is de originele handleiding. Lees alle instructies zorgvuldig door voordat u het product gebruikt. VEVOR behoudt zich het recht voor om de gebruiksaanwijzing duidelijk te interpreteren. Het uiterlijk van het product is afhankelijk van het product dat u hebt ontvangen. Neemt u het ons niet kwalijk dat we u niet meer op de hoogte stellen van eventuele technologische of software-updates voor ons product.

	<p>Waarschuwing - Om het risico op letsel te verminderen, moet de gebruiker de gebruiksaanwijzing lezen</p> <p>Lees de gebruiksaanwijzing zorgvuldig door.</p> <p><b>Let op: Montage door volwassenen vereist!</b></p>
	<p>Compliance is een CE-beveiligingscertificering.</p>
<p><b>Leeftijden</b></p>	<p>3 jaar +</p>

## VEILIGHEIDSINSTRUCTIES

### WAARSCHUWING:

**Lees dit materiaal voordat u dit product gebruikt. Als u dit niet doet, kan dit leiden tot: ernstig letsel tot gevolg hebben.**

### Vorzorgsmaatregelen bij de montage

1. Monteer uitsluitend volgens deze instructies. Onjuiste montage kan gevaren opleveren.
2. Zorg ervoor dat de verzamelplaats schoon en goed verlicht is.
3. De producteigenschappen gelden voor correct en volledig gemonteerde producten. alleen producten.
4. Monteer op een vlak, egaal, hard en glad oppervlak dat veilig kan worden gebruikt ter ondersteuning van de Kids Storage Benches.
5. Voor aanvullende informatie over de onderdelen die in de volgende lijst staan vermeld, Voor meer informatie over de montage, zie het montageschema van deze handleiding. Uitpakken en scheid alle onderdelen in een schone werkruimte.

### Gebruik voorzorgsmaatregelen

1. NIET OP DIT ITEM ZITTEN OF STAAN.
2. Dit product is geen speelgoed. Laat kinderen niet met of in de buurt van dit product spelen. item.
3. Overschrijd de aangegeven gewichtscapaciteit niet.
4. Gebruik het alleen op een vlak, egaal, hard en glad oppervlak dat veilig kan worden gebruikt. ondersteunen een volledig geladen Kids Storage Benches.
5. Gebruik het product alleen zoals bedoeld.
6. Controleer het product voor elk gebruik. Gebruik het product niet als er onderdelen loszitten of beschadigd zijn.

### BEWAAR DEZE HANDLEIDING

## INSTALLATIE VAN NOKKEN EN PENNEN

Schroef de pen in het gat. Om de nokken correct in te stellen, zorg ervoor dat de pijl op de nok naar het gat van de pen wijst die hij blokkeert. Vergrendel de nok door de nokkop met een schroevendraaier te draaien totdat deze vastzit.

Gebruik geen elektrische schroevendraaier om het apparaat te monteren.

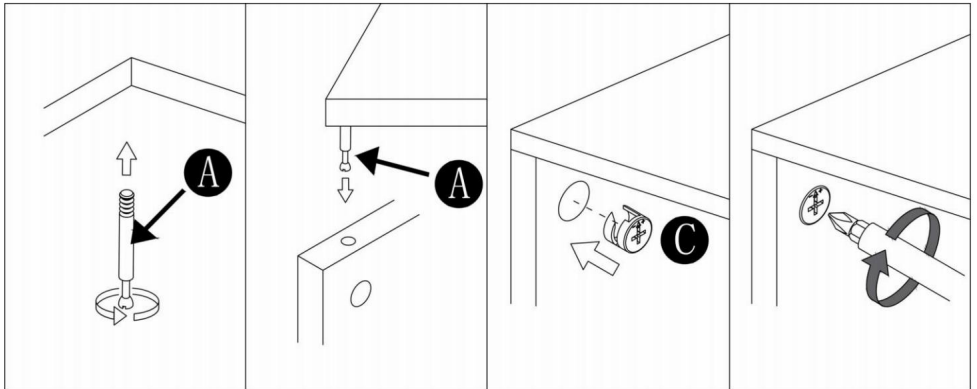



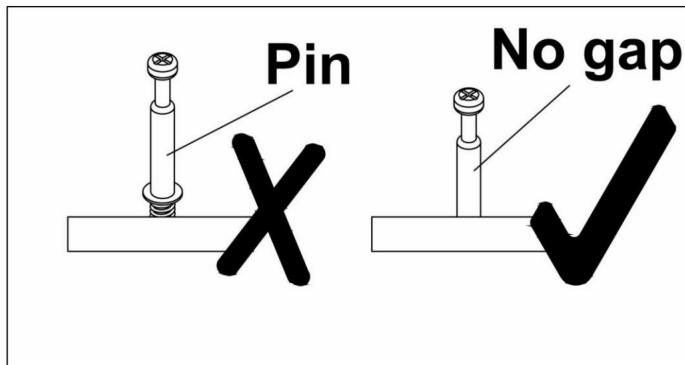



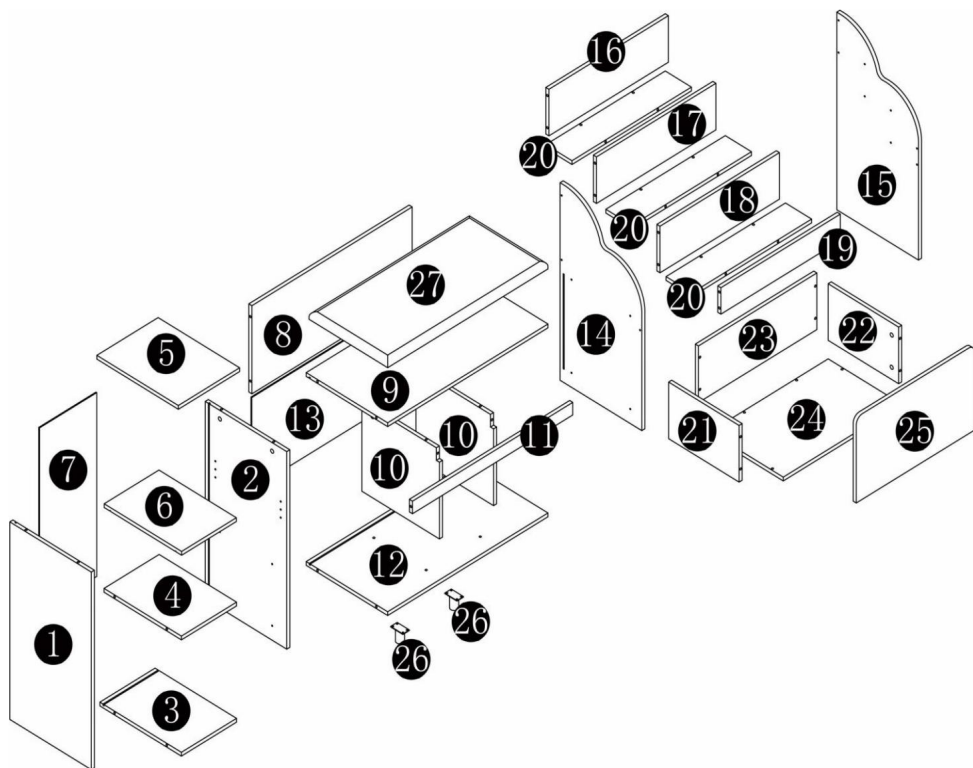



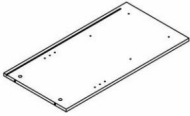
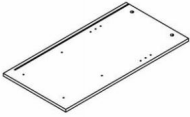

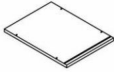
Lees elke stap zorgvuldig door voordat u begint. Het is erg belangrijk dat elke stap van de instructie in de juiste volgorde wordt uitgevoerd. Als deze stappen niet in de juiste volgorde worden gevolgd, kunnen er montageproblemen ontstaan.

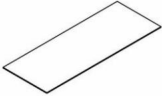

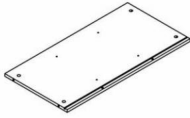

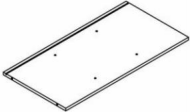
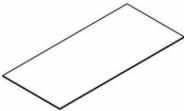
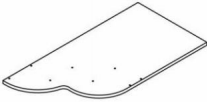
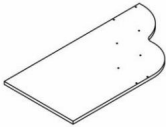

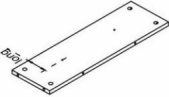
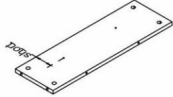
LIJST MET ONDERDELEN EN HARDWAREN

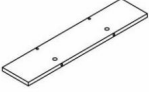



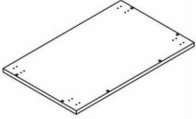

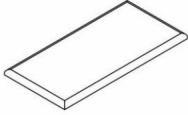





# Hardwarelijst

 <p><b>1</b> 1pc</p>	 <p><b>2</b> 1pc</p>	 <p><b>3</b> 1pc</p>	 <p><b>4</b> 1pc</p>
 <p><b>5</b> 1pc</p>	 <p><b>6</b> 1pc</p>	 <p><b>7</b> 1pc</p>	 <p><b>8</b> 1pc</p>
 <p><b>9</b> 1pc</p>	 <p><b>10</b> 2pcs</p>	 <p><b>11</b> 1pc</p>	 <p><b>12</b> 1pc</p>
 <p><b>13</b> 1pc</p>	 <p><b>14</b> 1pc</p>	 <p><b>15</b> 1pc</p>	 <p><b>16</b> 1pc</p>
 <p><b>17</b> 1pc</p>	 <p><b>18</b> 1pc</p>	 <p><b>19</b> 1pc</p>	 <p><b>20</b> 3pcs</p>

 <b>21</b> 1pc	 <b>22</b> 1pc	 <b>23</b> 1pc	 <b>24</b> 1pc
 <b>25</b> 1pc	 <b>26</b> 2pcs	 <b>27</b> 1pc	

### Onderdelenlijst

 <b>A</b> 58pcs	 <b>B</b> M7X50MM 22pcs	 <b>C</b> 58pcs	 <b>P</b> M3. 5X12MM 36pcs	 <b>Q</b> 4pcs
 <b>U</b> 12pcs	 <b>Y</b> 1.5" 4pcs	 <b>Z</b> φ20 58pcs		

# MONTAGESTAP

1

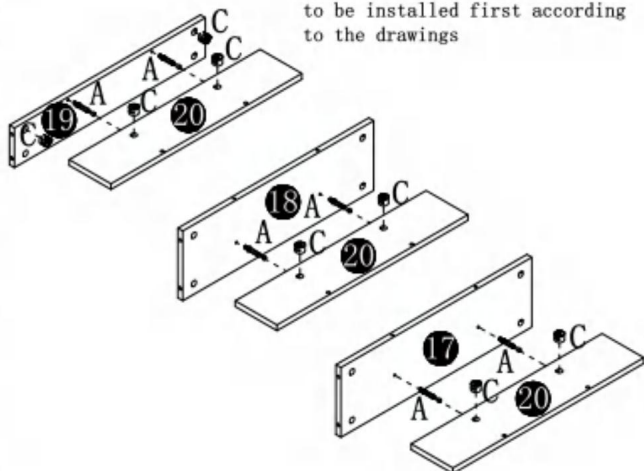
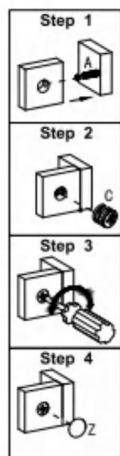

Please note that for Board 19, two accessories numbered C need to be installed first according to the drawings

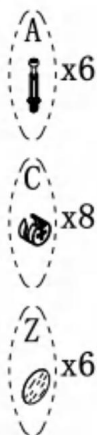

2

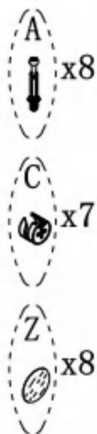
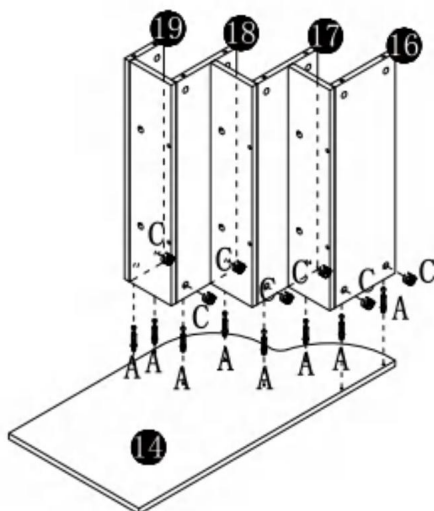
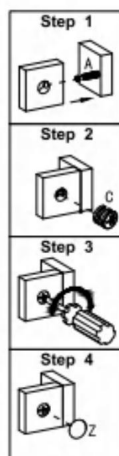

3

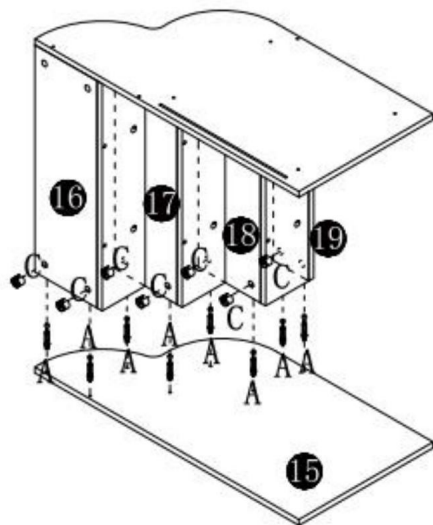
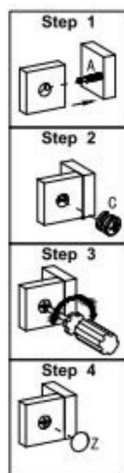

4

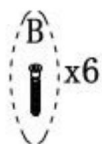
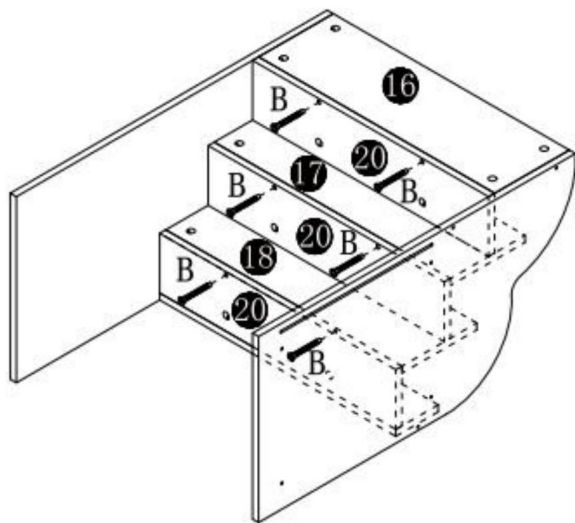

5

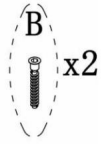
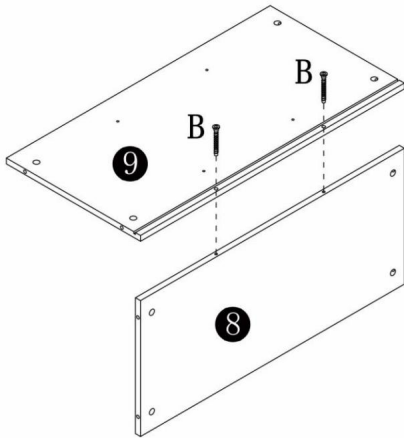

6

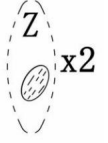
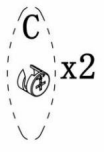
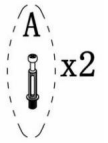
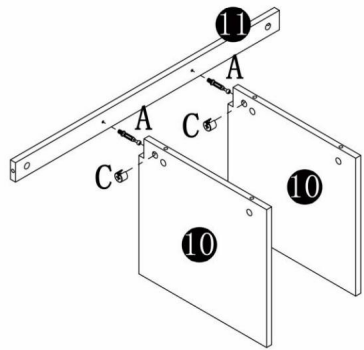
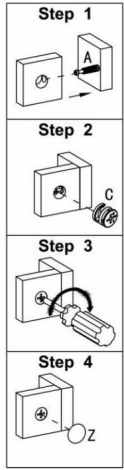

7

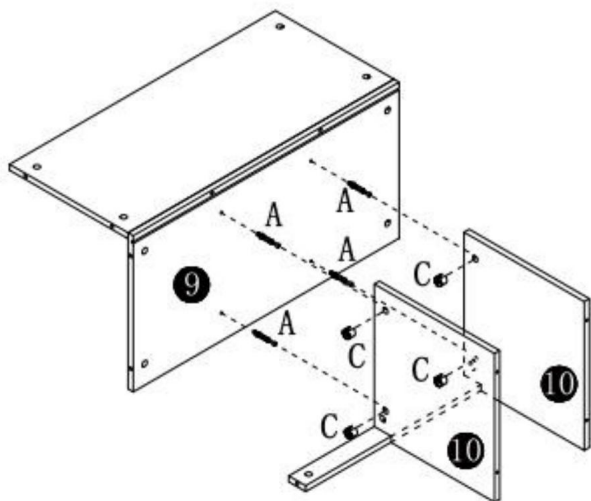
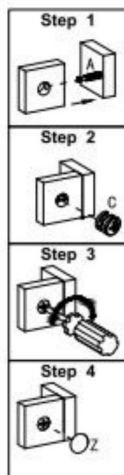

8

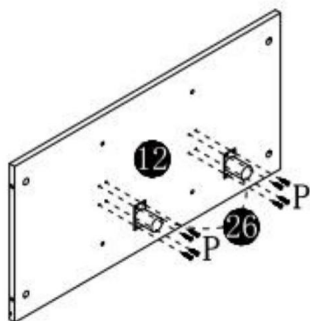
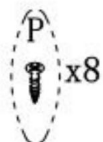

9

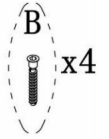
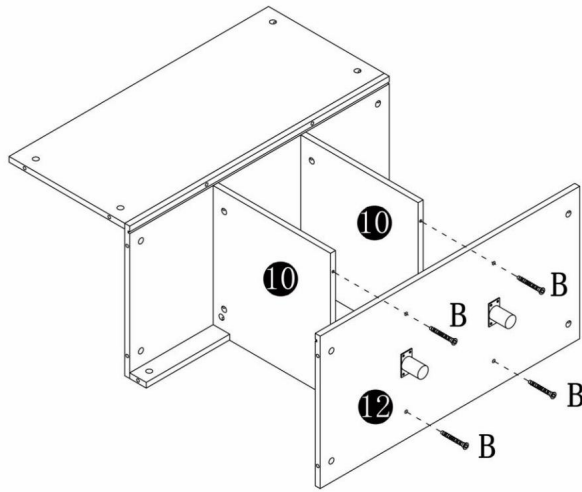

10

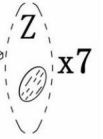
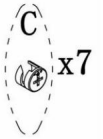
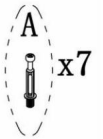
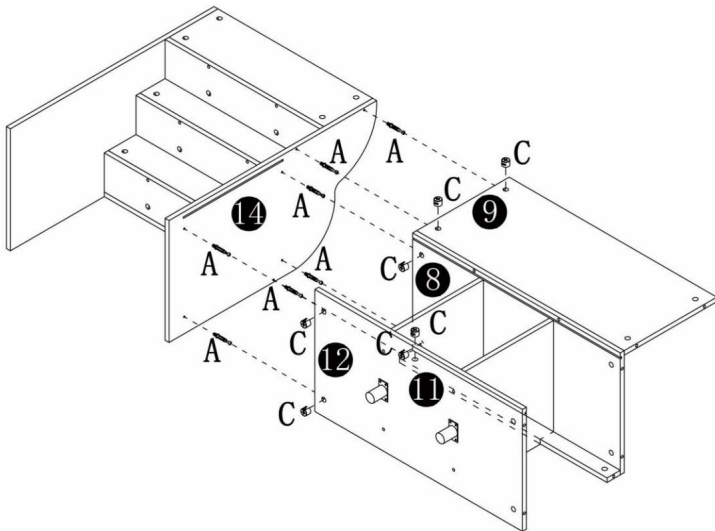
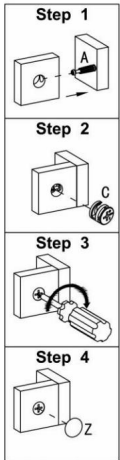

11

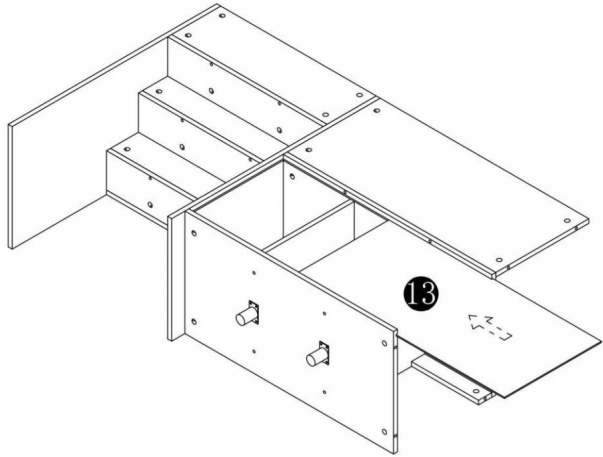

12

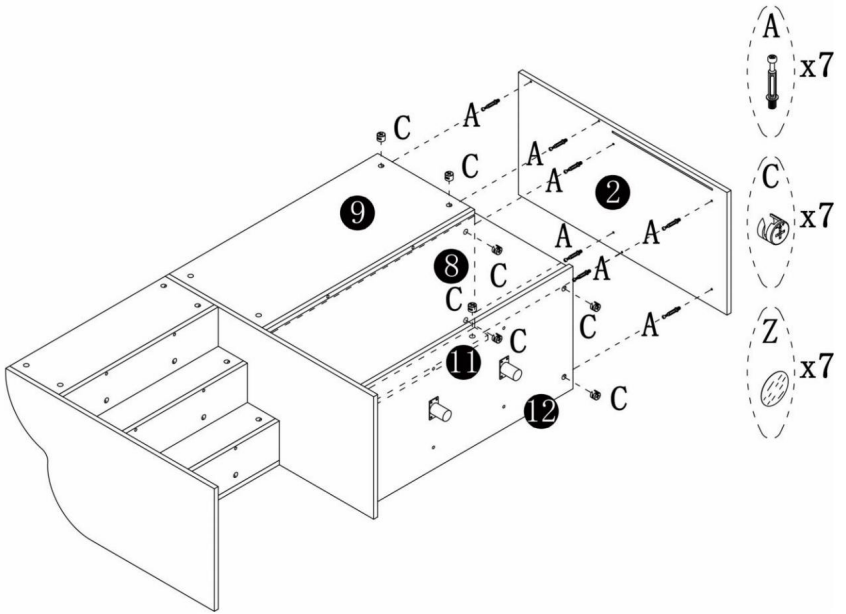
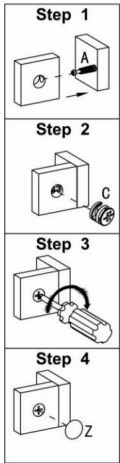

13

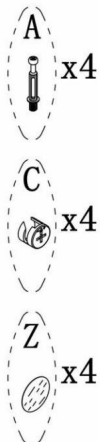
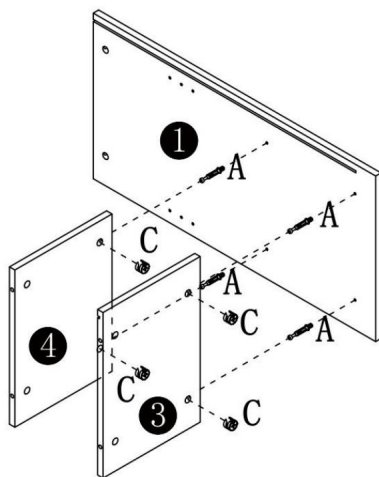
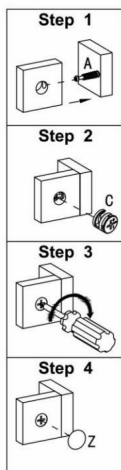

14

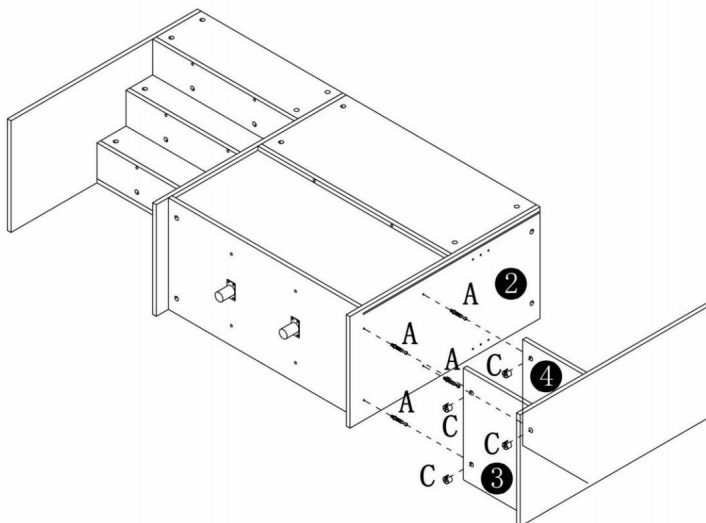
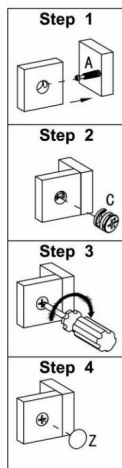

15

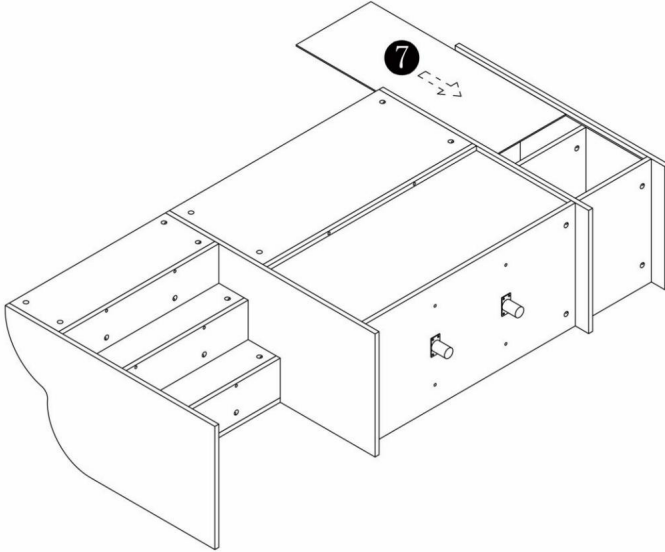

16

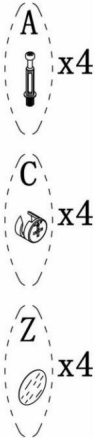
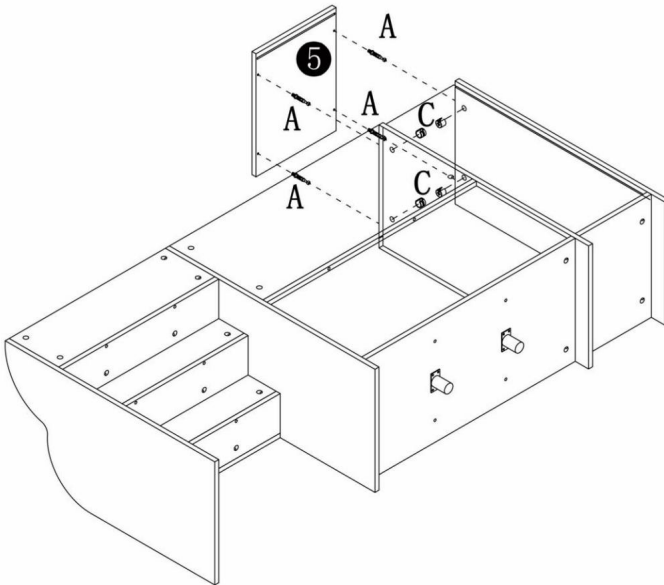
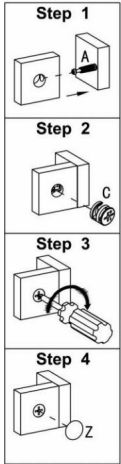

17

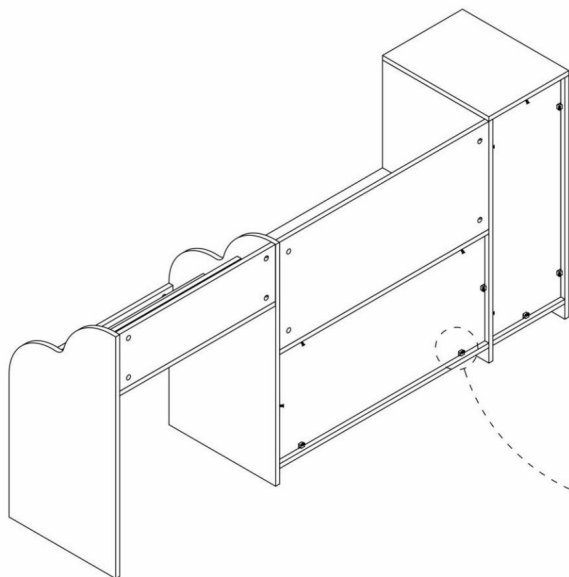

U  
x12

P  
x12

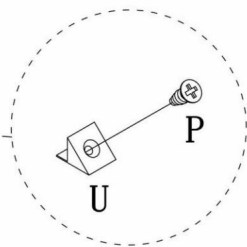

18

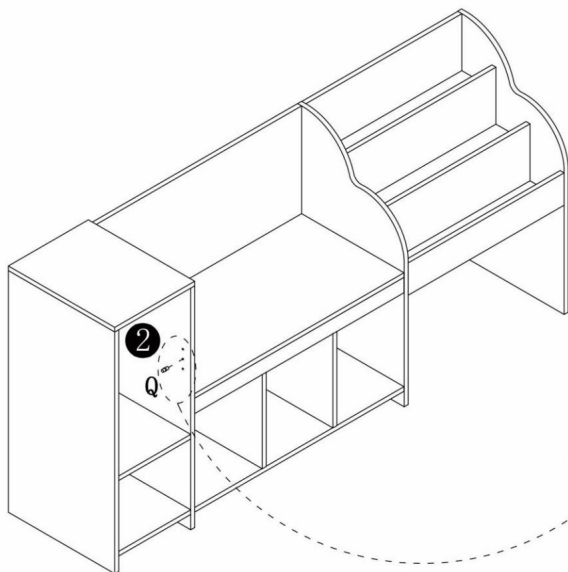

Q  
x4

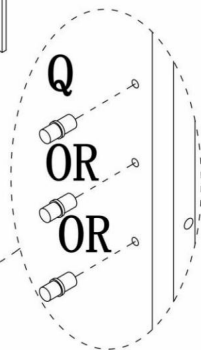

19

De verplaatsbare plank kan worden op drie posities geplaatst.

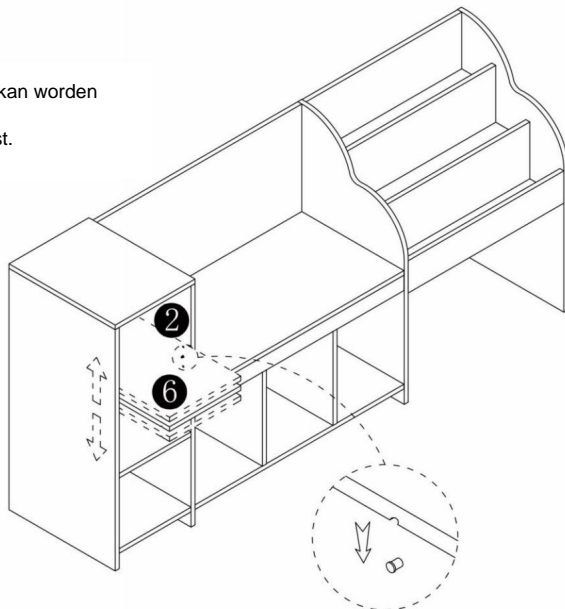

20

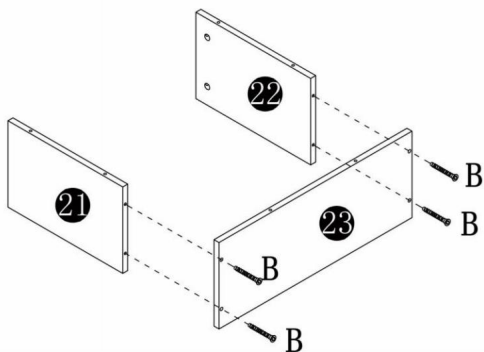
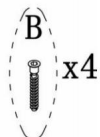

# 21

Richtingswielen kunnen alleen vooruit en achteruit bewegen, terwijl niet-universele wielen niet 360 graden kunnen draaien.

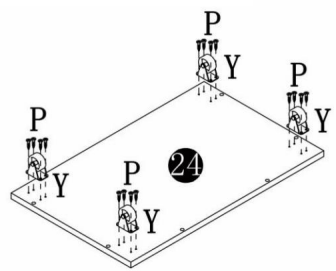
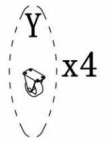
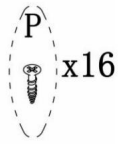

# 22

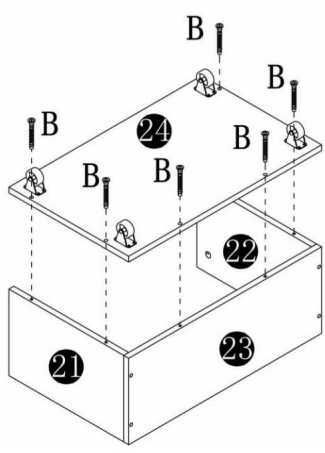
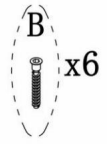

23

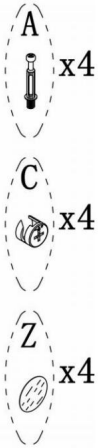
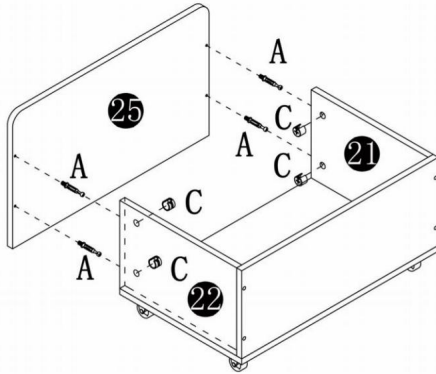
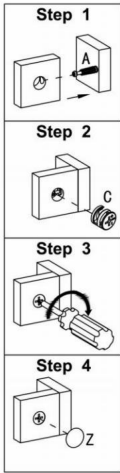

24

Het zeepkussen heeft een rits en is afneembaar voor reiniging.

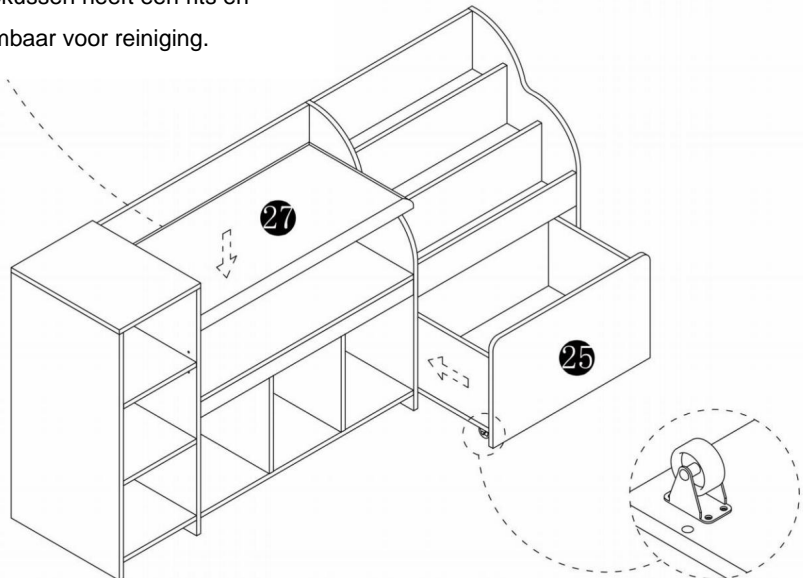

## PRODUCTPARAMETER

<b>Model</b>	C250224D-01
<b>Statische lastdragende</b>	MAXIMAAL 350 pond
<b>Kleur</b>	Wit
<b>Productgrootte</b>	1700×400×800mm

**Fabrikant:** Guangzhou Dingxin Office Furniture Co., LTD **Adres van de**

**fabrikant:** No. 1700, Renhe Road, Aotou Town, Conghua District, Guangzhou, provincie

Guangdong **Geïmporteerd naar AUS:** SIHAO PTY

LTD. 1 ROKEVA STREETEASTWOOD NSW 2122 Australië

**Geïmporteerd naar de VS:** Sanven Technology Ltd. Suite 250, 9166 Anaheim Place,

Rancho Cucamonga, CA 91730



YH CONSULTING LIMITED. T.a.v. YH Consulting Limited

Kantoor 147, Centurion House, London Road, Staines-

upon-Thames, Surrey, TW18 4AX



E-CrossStu GmbH

Mainzer Landstr.69,

60329 Frankfurt am Main.



# VEVOR

**Affordable. Reliable. Home Improvement.**





**FÖRVARINGSBÄNKAR FÖR BARN**

**MODELL: C250224D-01**

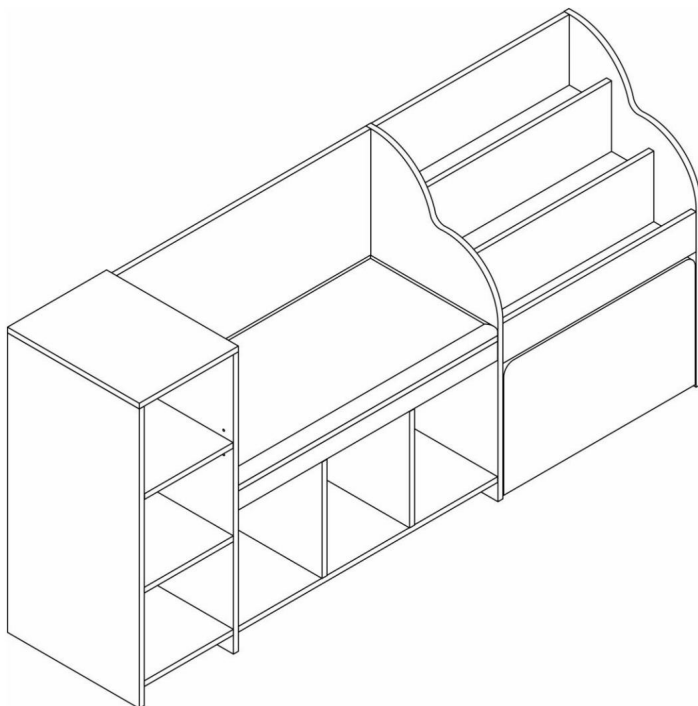
MODELL: C250224D-01



Detta är originalinstruktionerna, vänligen läs alla instruktioner noggrant innan du använder produkten. VEVOR förbehåller sig en tydlig tolkning av vår användarmanual. Produktens utseende ska vara beroende av den produkt du mottagit. Vi ber om ursäkt för att vi inte kommer att informera dig igen om det finns några teknik- eller programuppdateringar för vår produkt.

	Varning – För att minska risken för skador måste användaren läsa bruksanvisningen noggrant. <b>Obs: Montering krävs av vuxna!</b>
	Efterlevnad är en CE-säkerhetscertifiering.
<b>Åldrar</b>	3 år +

## SÄKERHETSINSTRUKTIONER

### VARNING:

**Läs detta material innan du använder produkten. Underlåtenhet att göra det kan resultera i allvarliga skador.**

### Monteringsförsiktighetsåtgärder

1. Montera endast enligt dessa instruktioner. Felaktig montering kan skapa faror.
2. Håll samlingsområdet rent och väl upplyst.
3. Produktens egenskaper gäller för korrekt och fullständigt monterade endast produkter.
4. Montera på en plan, jämn, hård och slät yta som säkert kan användas stödjer förvaringsbänkarna för barn.
5. För ytterligare information om de delar som listas i följande sidor, vänligen se monterings-schemat i denna manual. Packa upp och separera alla delar på en ren arbetsyta.

### Använd försiktighetsåtgärder

1. SITTA ELLER STÅ INTE PÅ DENNA FÖRENING.
2. Denna produkt är inte en leksak. Låt inte barn leka med eller i närheten av denna punkt.
3. Överskrid inte angivna viktkapaciteter.
4. Använd endast på en plan, jämn, hård och slät yta som säkert kan stödja en fullt lastad förvaringsbänk för barn.
5. Använd endast enligt avsikten.
6. Kontrollera före varje användning; använd inte om delar är lösa eller skadade.

### SPARA DENNA HANDBOK

## INSTALLATION AV KAMMAR OCH STIFT

Skruva fast stiftet i hålet. För att justera kammarna korrekt, se till att pilen på kammen öppnas mot hålet på stiftet den låser. Lås kammen genom att vrida kamhuvudet med en skruvmejsel tills det är åtdraget.

Använd inte en elektrisk

skruvmejsel för att montera enheten.

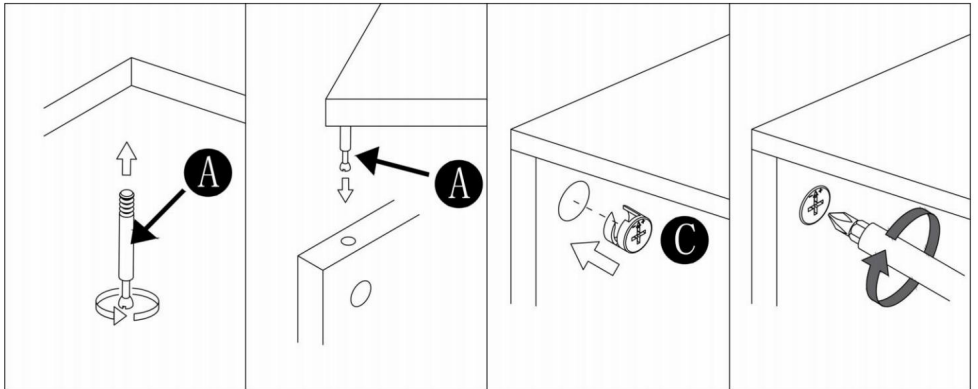



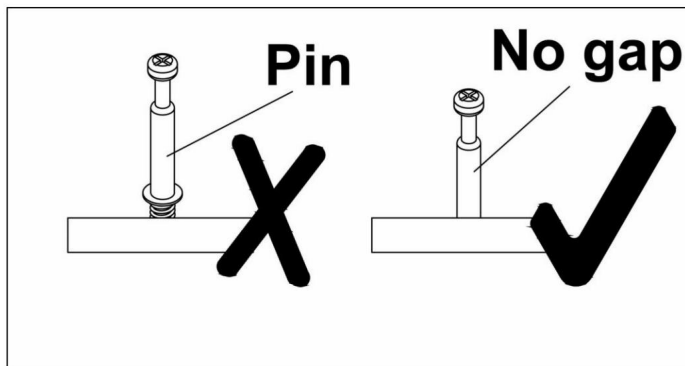



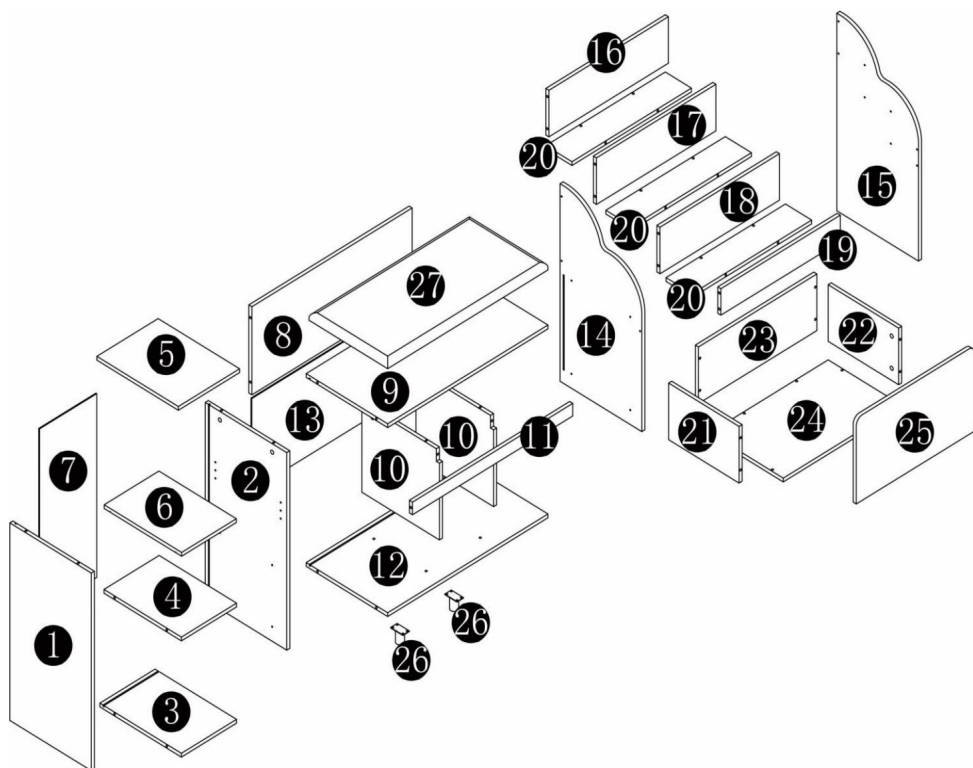



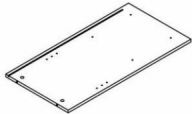
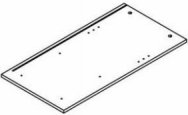

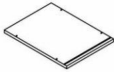

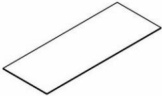
Läs varje steg noggrant innan du börjar. Det är mycket viktigt att varje steg i instruktionerna utförs i rätt ordning. Om dessa steg inte följs i rätt ordning kommer monteringsproblem att uppstå.



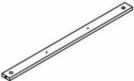
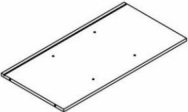
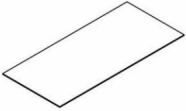

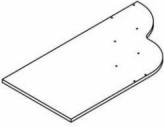

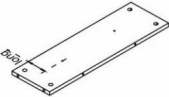
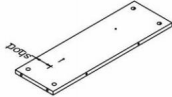
## DEL- OCH HÅRDVARULISTA

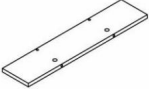



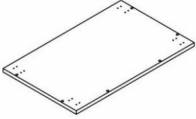

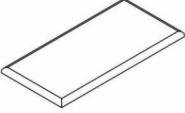





# Hårdvarulista

 <p><b>1</b> 1pc</p>	 <p><b>2</b> 1pc</p>	 <p><b>3</b> 1pc</p>	 <p><b>4</b> 1pc</p>
 <p><b>5</b> 1pc</p>	 <p><b>6</b> 1pc</p>	 <p><b>7</b> 1pc</p>	 <p><b>8</b> 1pc</p>
 <p><b>9</b> 1pc</p>	 <p><b>10</b> 2pcs</p>	 <p><b>11</b> 1pc</p>	 <p><b>12</b> 1pc</p>
 <p><b>13</b> 1pc</p>	 <p><b>14</b> 1pc</p>	 <p><b>15</b> 1pc</p>	 <p><b>16</b> 1pc</p>
 <p><b>17</b> 1pc</p>	 <p><b>18</b> 1pc</p>	 <p><b>19</b> 1pc</p>	 <p><b>20</b> 3pcs</p>

 <b>21</b> 1pc	 <b>22</b> 1pc	 <b>23</b> 1pc	 <b>24</b> 1pc
 <b>25</b> 1pc	 <b>26</b> 2pcs	 <b>27</b> 1pc	

## Dellista

 <b>A</b> 58pcs	 <b>B</b> 22pcs M7X50MM	 <b>C</b> 58pcs	 <b>P</b> 36pcs M3.5X12MM	 <b>Q</b> 4pcs
 <b>U</b> 12pcs	 <b>Y</b> 4pcs 1.5"	 <b>Z</b> 58pcs φ20		

## MONTERINGSSTEG

1

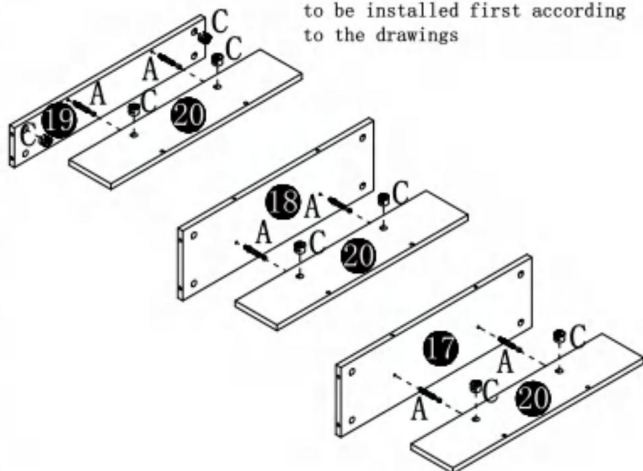
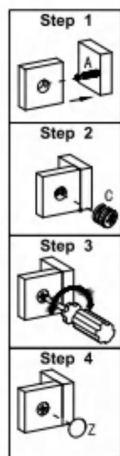

Please note that for Board 19, two accessories numbered C need to be installed first according to the drawings

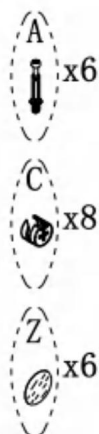

2

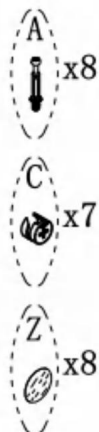
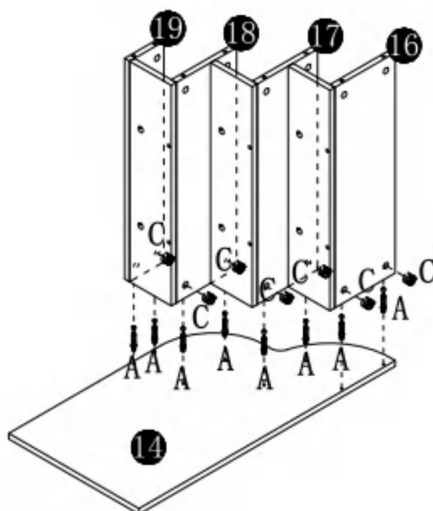
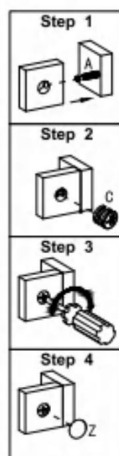

3

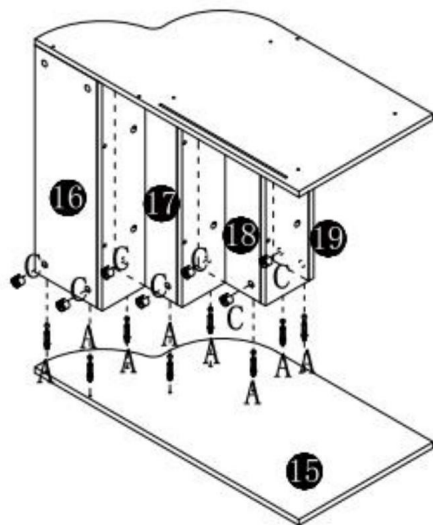
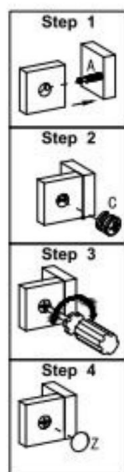

4

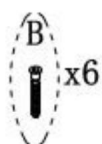
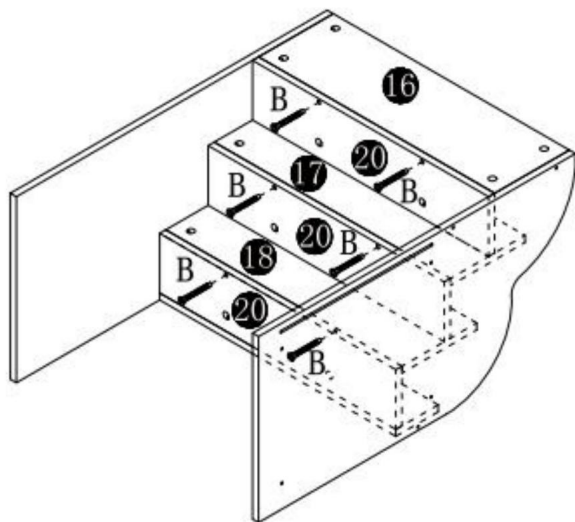

5

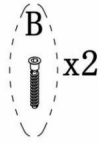
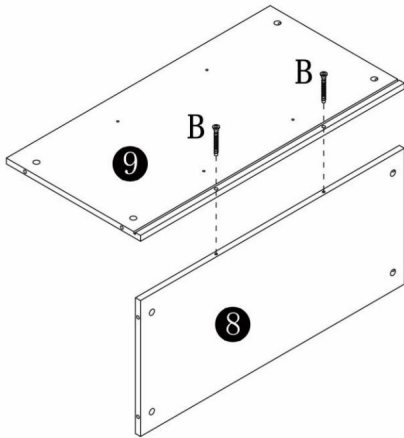

6

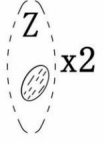
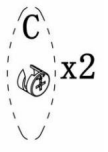
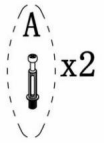
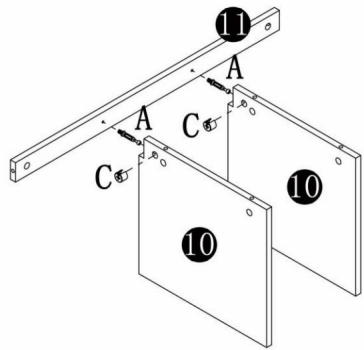
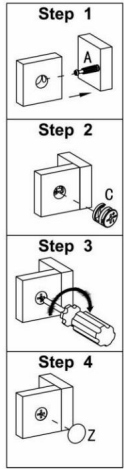

7

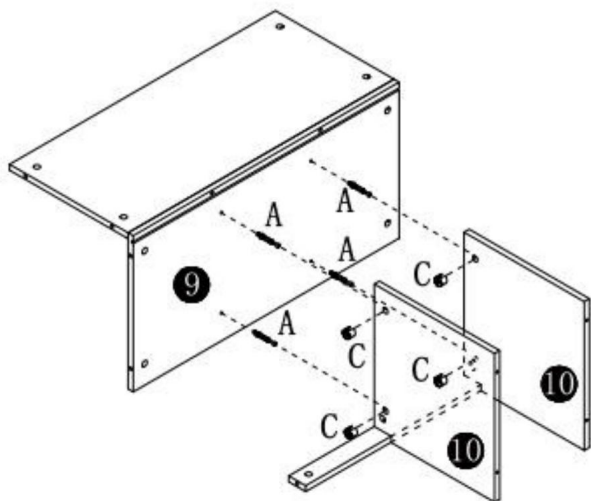
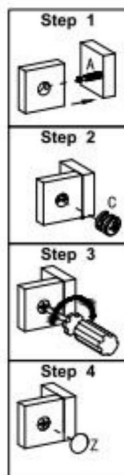

8

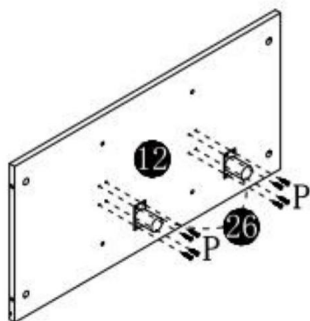
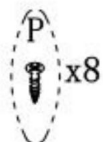

9

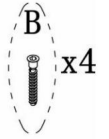
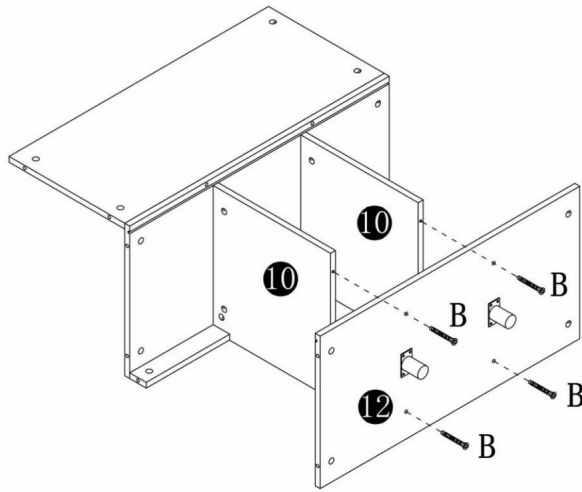

10

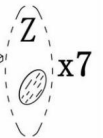
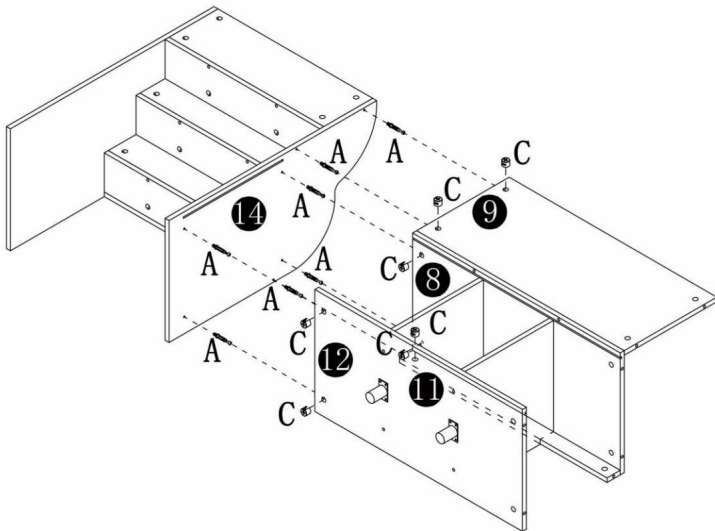
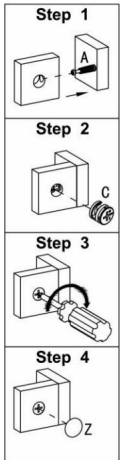

11

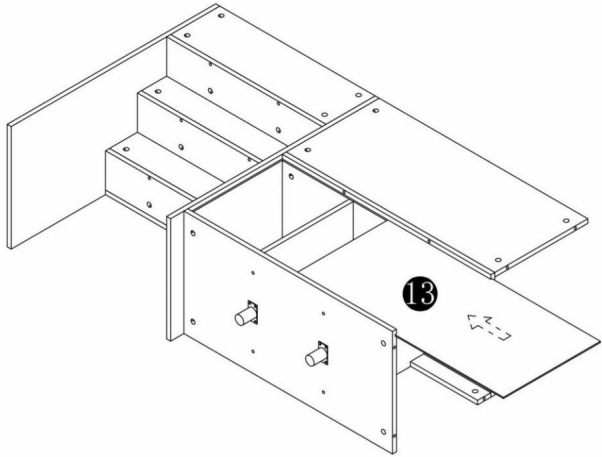

12

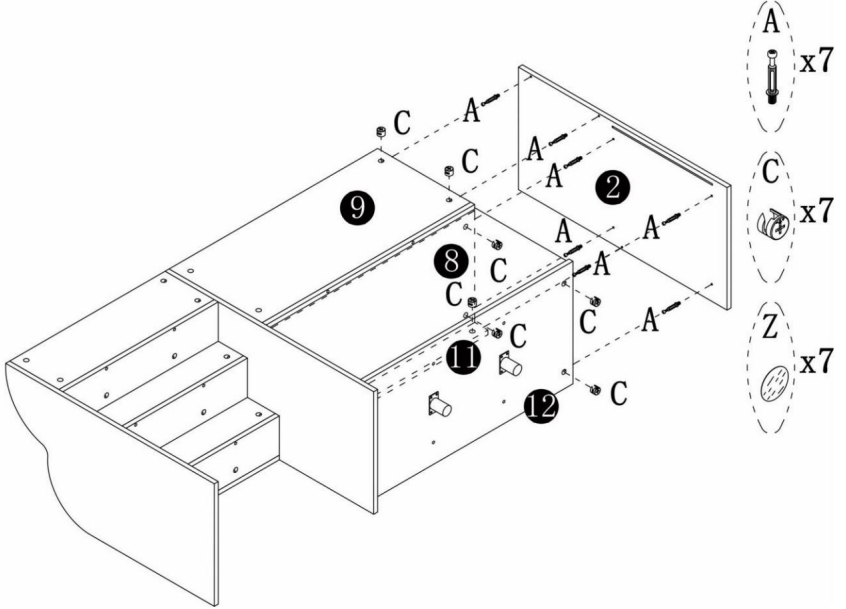
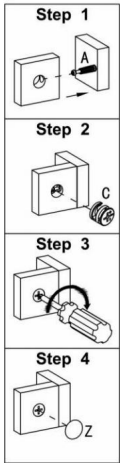

# 13

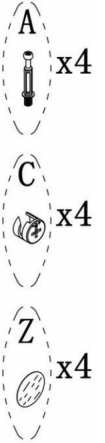
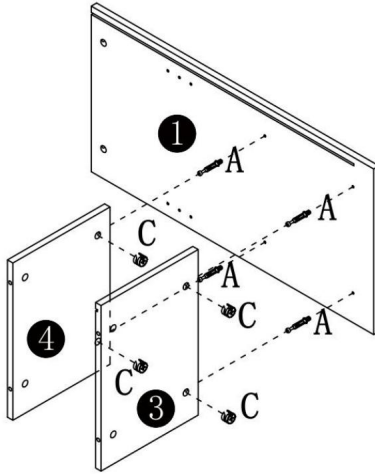
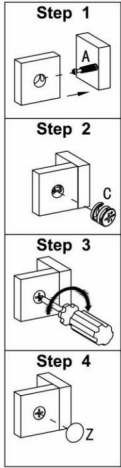

# 14

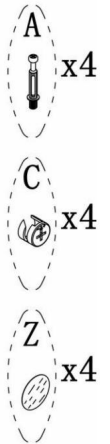
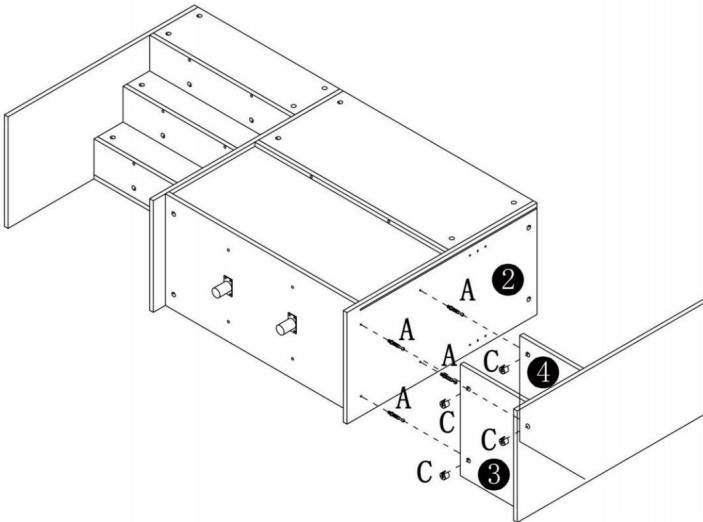
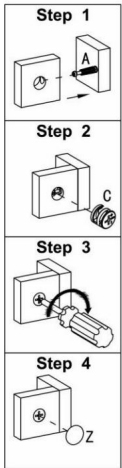

15

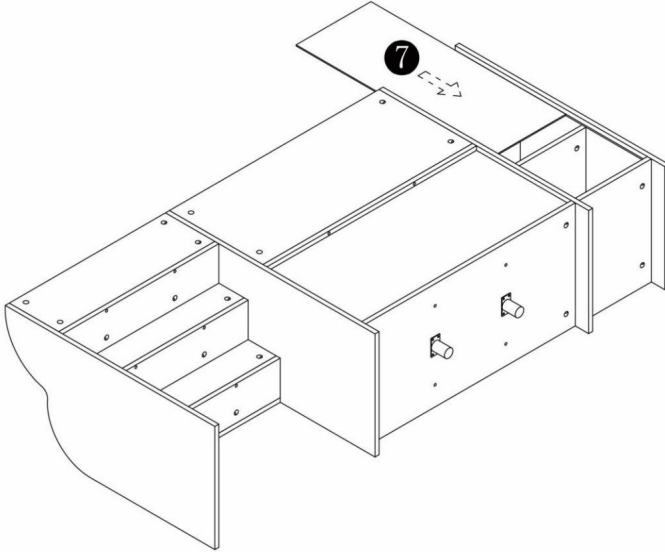

16

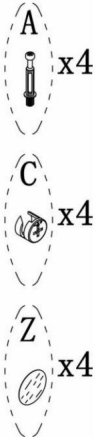
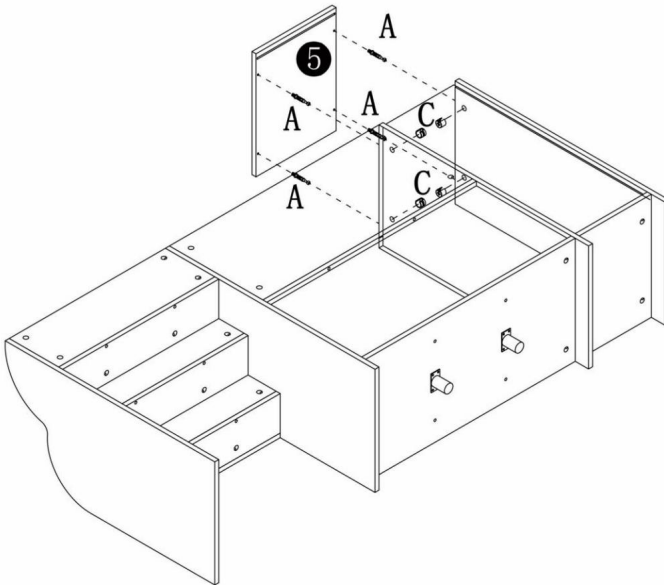
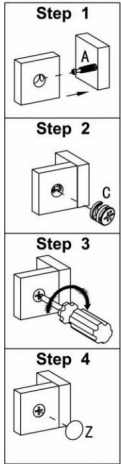

17

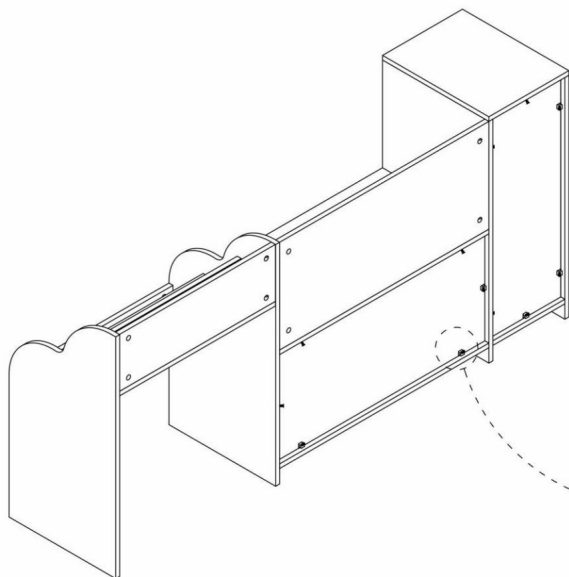

U  
x12

P  
x12

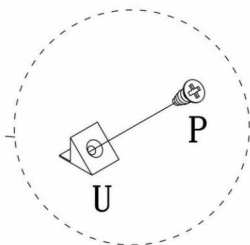

18

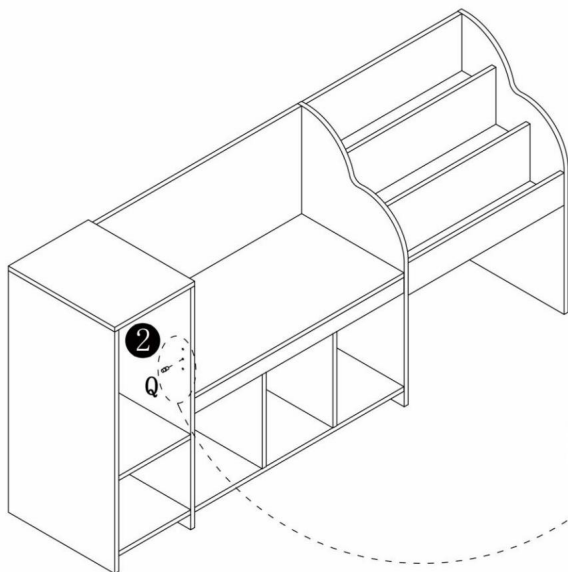

Q  
x4

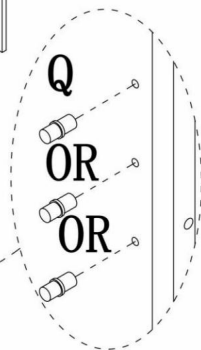

19

Den flyttbara hyllan kan vara  
placerade på tre positioner.

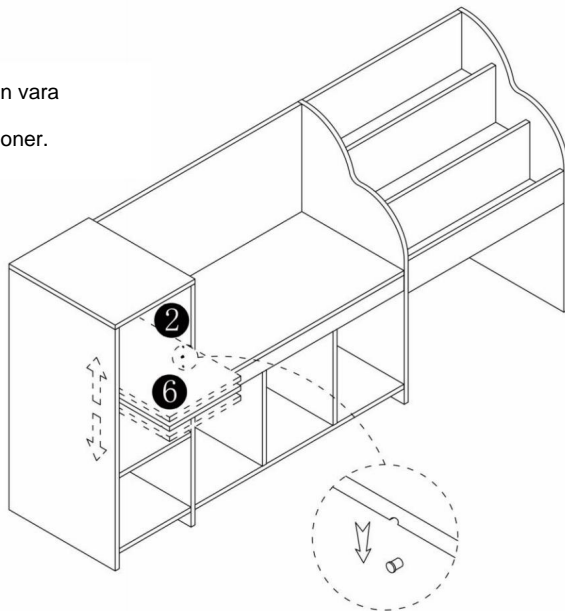

20

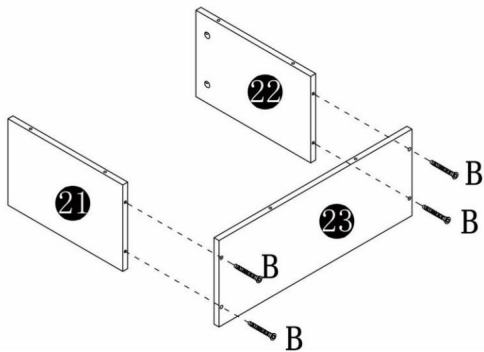
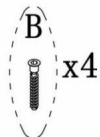

21

Riktningshjul kan bara röra sig framåt och bakåt, medan icke-universella hjul inte kan rotera 360 grader.

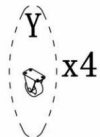
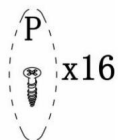
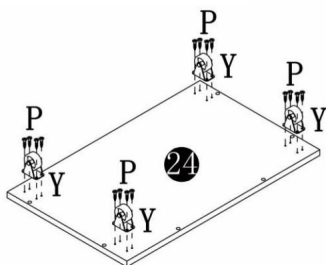

22

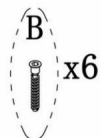
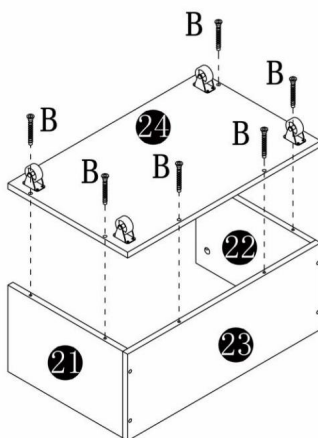

23

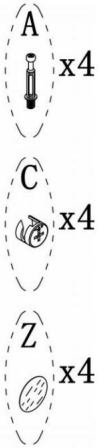
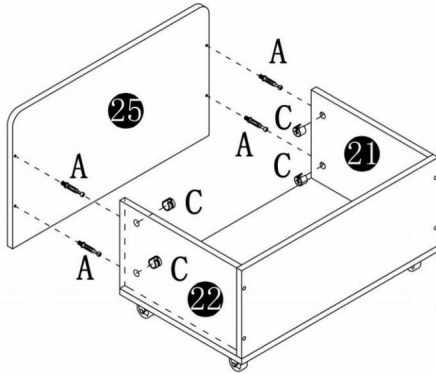
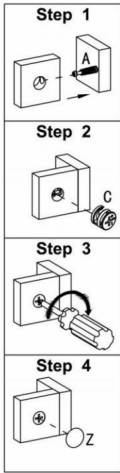

24

Sittdynan har dragkedja och är avtagbar för rengöring.

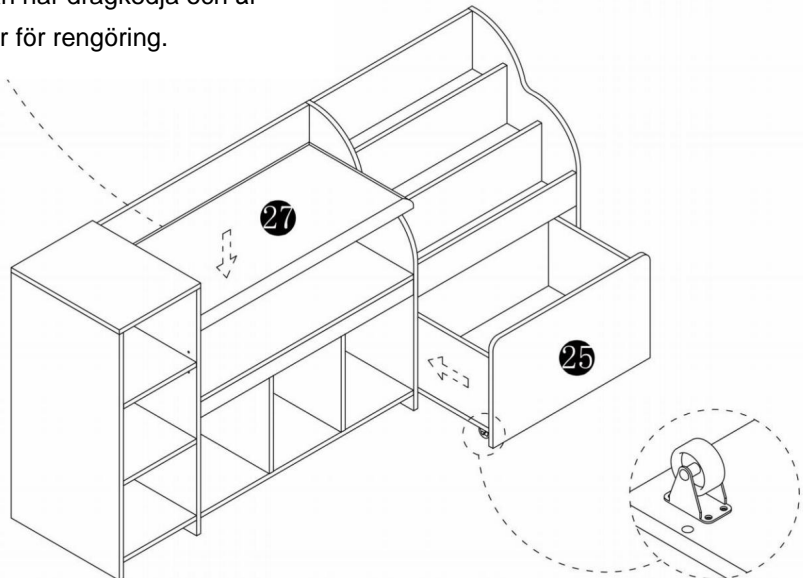

## PRODUKTPARAMETER

<b>Modell</b>	C250224D-01
<b>Statisk lastbärande</b>	MAX 147 kg
<b>Färg</b>	Vit
<b>Produktstorlek</b>	1700×400×800 mm

**Tillverkare:** Guangzhou Dingxin Office Furniture Co., LTD **Tillverkarens**

**adress:** No. 1700, Renhe Road, Aotou Town, Conghua District, Guangzhou, Guangdong-provinsen **Importerad till Australien:** SIHAO PTY

LTD. 1 ROKEVA STREETEASTWOOD NSW 2122 Australien

**Importerad till USA:** Sanven Technology Ltd. Suite 250, 9166 Anaheim Place, Rancho Cucamonga, CA 91730

Storbritanniens republikane	
-----------------------------	--

YH CONSULTING LIMITED. C/O YH Consulting Limited  
Kontor 147, Centurion House, London Road, Staines-upon-Thames, Surrey, TW18 4AX

EG-representant	
-----------------	--

E-CrossStu GmbH  
Mainzer Landstr. 69,  
60329 Frankfurt am Main.

