

VEVOR

Affordable. Reliable. Home Improvement.

EXECUTIVE DESK

MODEL: C250243D-01

VEVOR

Affordable. Reliable. Home Improvement.

EXECUTIVE DESK

MODEL: C250243D-01

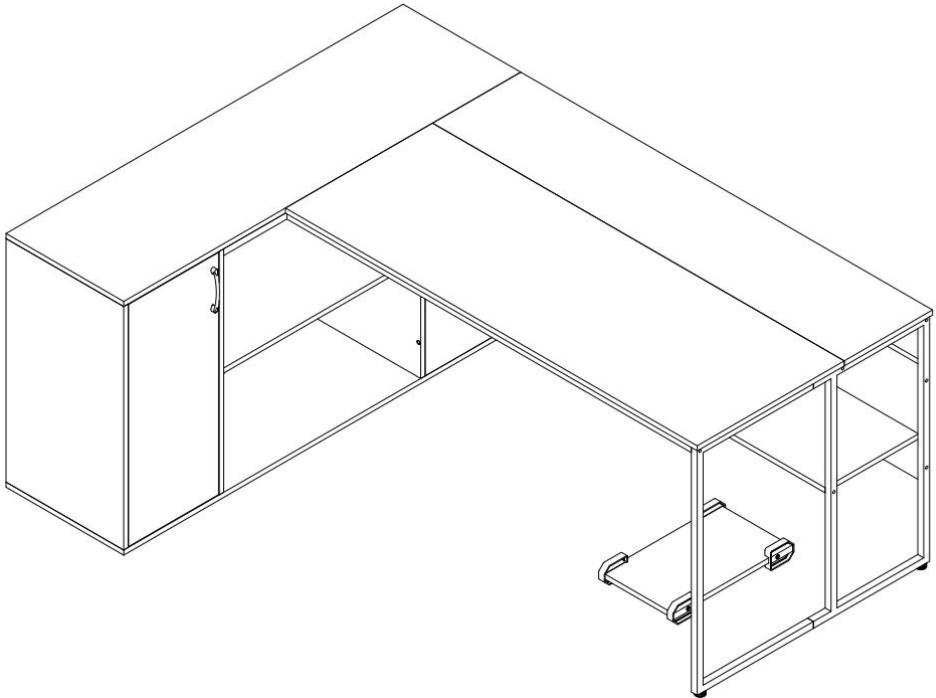

This is the original instruction, please read all manual instructions carefully before operating. VEVOR reserves a clear interpretation of our user manual. The appearance of the product shall be subject to the product you received. Please forgive us that we won't inform you again if there are any technology or software updates on our product.

SAFETY INSTRUCTIONS

INTRODUCTION

Thank you for purchasing our products. Committed to providing customers with the best quality products and service has always been our lifelong goal. Before using the product, please read this instruction manual carefully to ensure correct use. Keep the instruction manual in a place where the user can find it at any time.

ASSEMBLY PRECAUTIONS

There are many components and accessories in the package. Each component and accessory is labeled with a letter or a number, check carefully before using any of them. Keep them away from children to prevent accidents.

1. Assemble only according to these instructions. Improper assembly may create hazards.
2. Wear ANSI-approved safety goggles and heavy-duty work gloves during assembly.
3. Keep the assembly area clean and well-lit.
4. Keep bystanders out of the area during assembly.
5. Do not assemble if tired or when under the influence of alcohol, drugs or medication.
6. The product capabilities apply to properly and completely assembled products only.
7. Please install the product on a clean and soft underlay(such as carpet or cardboard)to avoid scratching or damaging the surface of the product.
8. If possible, you can use power tools to make assembly easier.
9. The main components of the product is relatively heavy. Please pay attention to safety during installation.
10. The product is not stable during installation, Please do not move it randomly before it is completely installed.

11. For additional information regarding the parts listed in the following pages, please refer to the Assembly Diagram of this manual. Unwrap and separate all parts in a clean work area.

***PLEASE BE SURE TO FOLLOW THE INSTALLATION STEPS IN THE MANUAL TO AVOID UNNECESSARY LOSSES CAUSED BY IMPROPER INSTALLATION.**

USE PRECAUTIONS







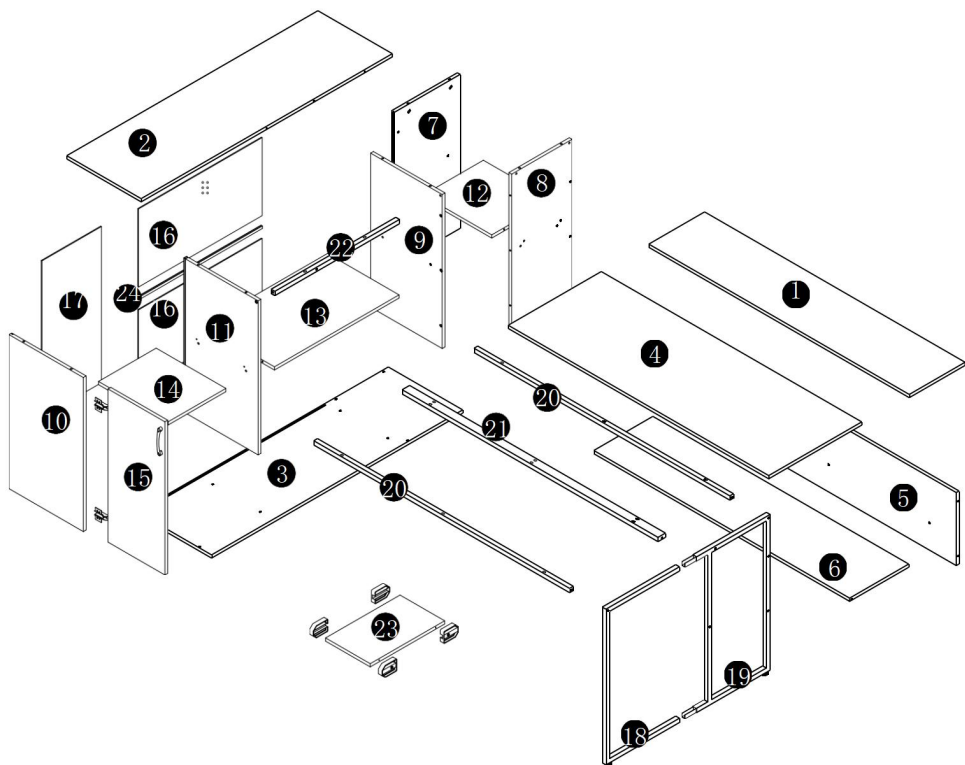







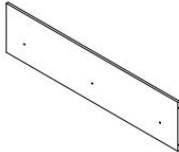

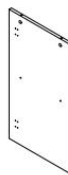

- 1) Do not exceed specified weight capacities.
- 2) Use only on a flat, level, hard, and smooth surface that can safely support a fully loaded Executive Desk.
- 3) Use as intended only.
- 4) Inspect before every use; do not use if parts are loose or damaged.

SAVE THIS MANUAL



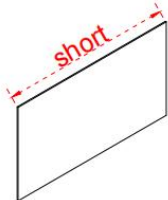
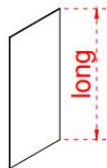

EXPLODED VIEW



















PARTS LIST

 <p>1 1pc</p>	 <p>2 1pc</p>	 <p>3 1pc</p>	 <p>4 1pc</p>
 <p>5 1pc</p>	 <p>6 1pc</p>	 <p>7 1pc</p>	 <p>8 1pc</p>
 <p>9 1pc</p>	 <p>10 1pc</p>	 <p>11 1pc</p>	 <p>12 1pc</p>
 <p>13 1pc</p>	 <p>14 1pc</p>	 <p>15 1pc</p>	 <p>16 2pcs</p>
 <p>17 1pc</p>	 <p>18 1pc</p>	 <p>19 1pc</p>	 <p>20 2pcs</p>

PARTS LIST

 21 1pc	 22 1pc	 23 1pc	 24 1pc
---	--	--	--

 M6X40MM A 14pcs	 M7X50MM B 34pcs	 C 14pcs	 M6X30MM F 14pcs	 M6X40MM H 8pcs
 K 22pcs	 M6X10MM N 4pcs	 M4X18MM O 2pcs	 ST3. 5X12MM P 38pcs	 Q 1pc
 DWX15MM T 2pcs	 U 4pcs	 X 3pcs	 M8X14MM Y 2pcs	 1pc
				

ASSEMBLY STEP

Installation of Cams and Pins

Screw the pin into the hole. To set the cams correctly, ensure that the arrow on the cam is opening to the hole of the pin it is locking. Lock the cam by turning the cam head with a screwdriver until it is tightened. Please do not use an electric screwdriver to assemble the unit.

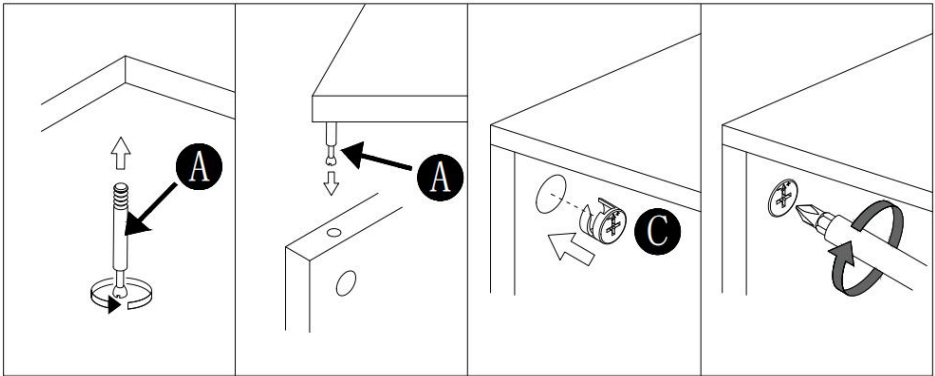

Read each step carefully before starting. It is very important that each step of instruction is performed in the correct order. If these steps are not followed in sequence, assembly difficulties will occur.

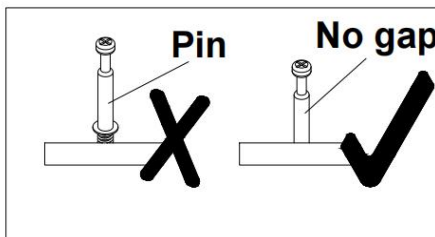

ASSEMBLY STEP

1

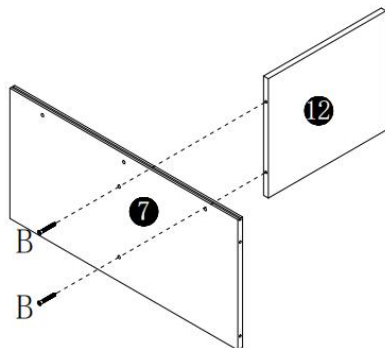
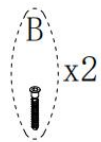

2

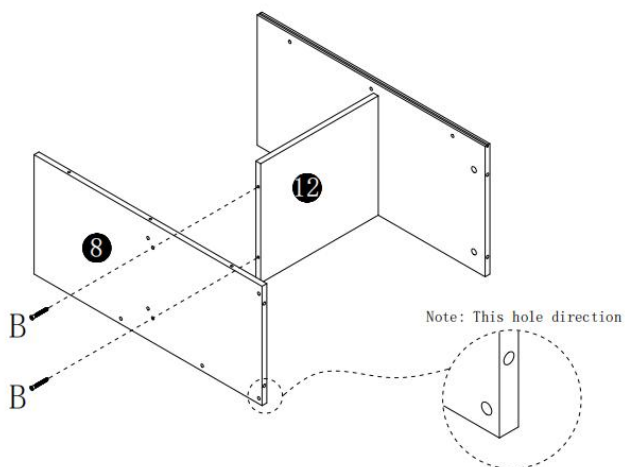
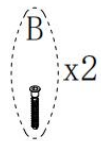

ASSEMBLY STEP

3

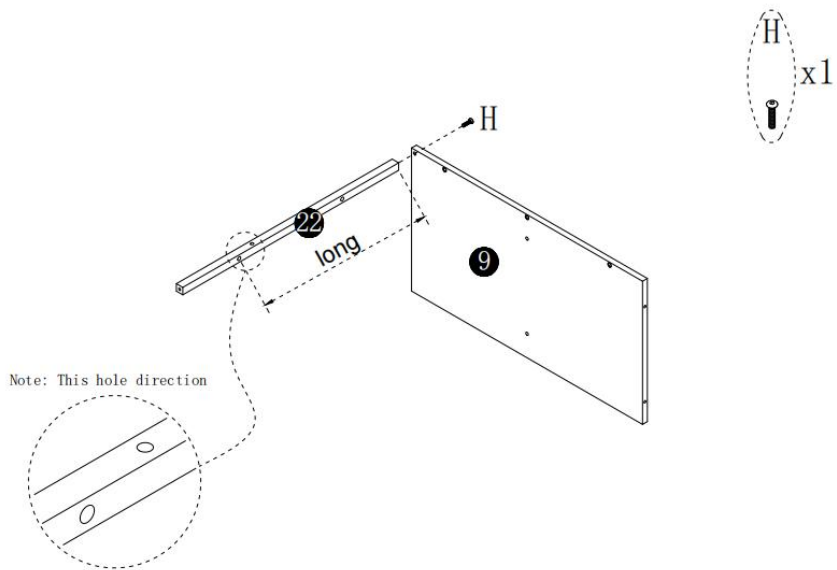

4

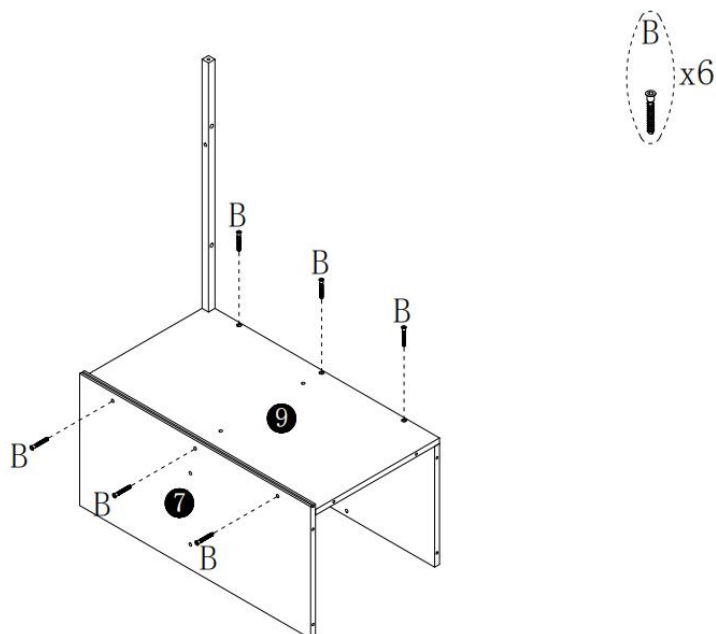

ASSEMBLY STEP

5

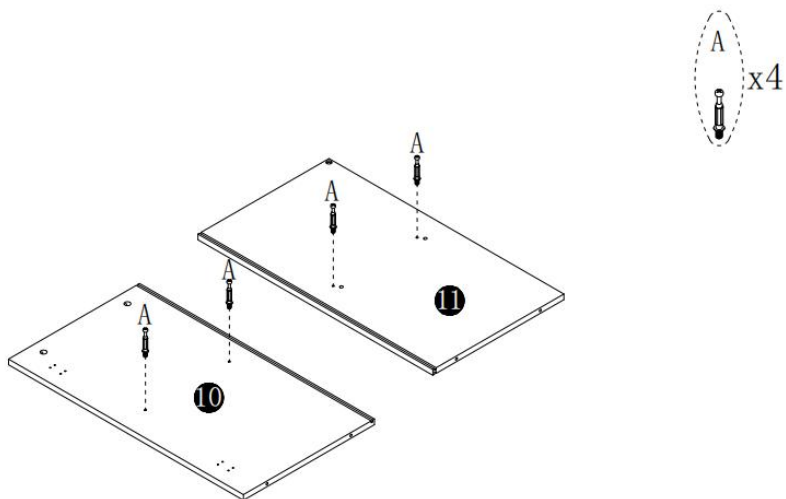

6

Note: This hole direction

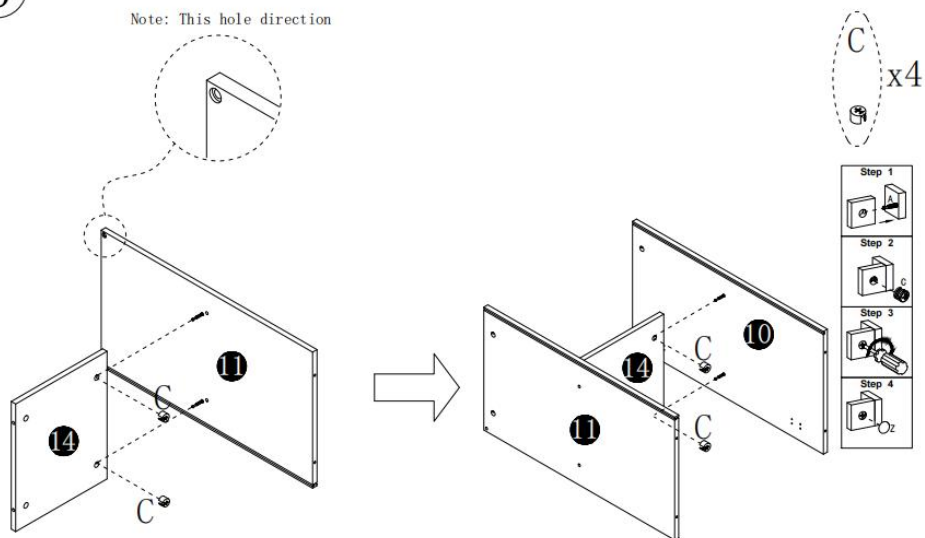

ASSEMBLY STEP

7

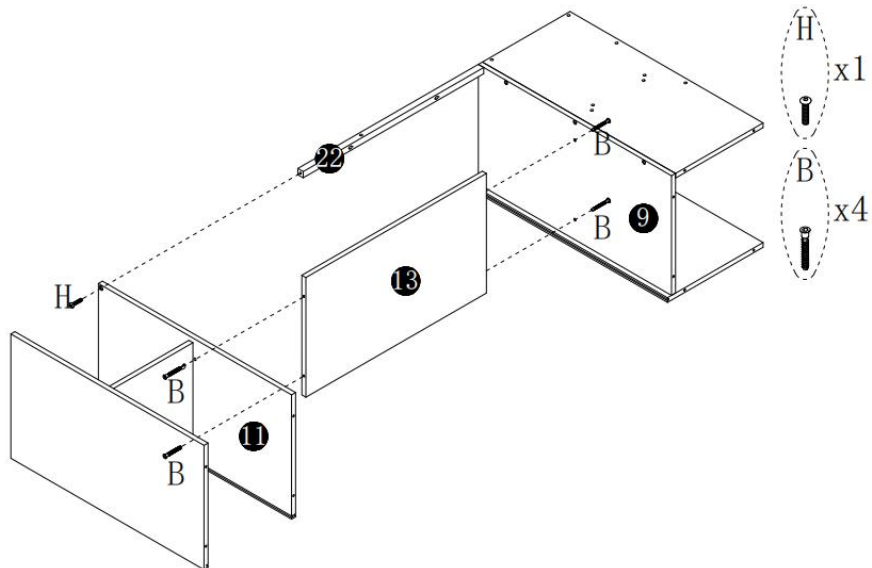

8

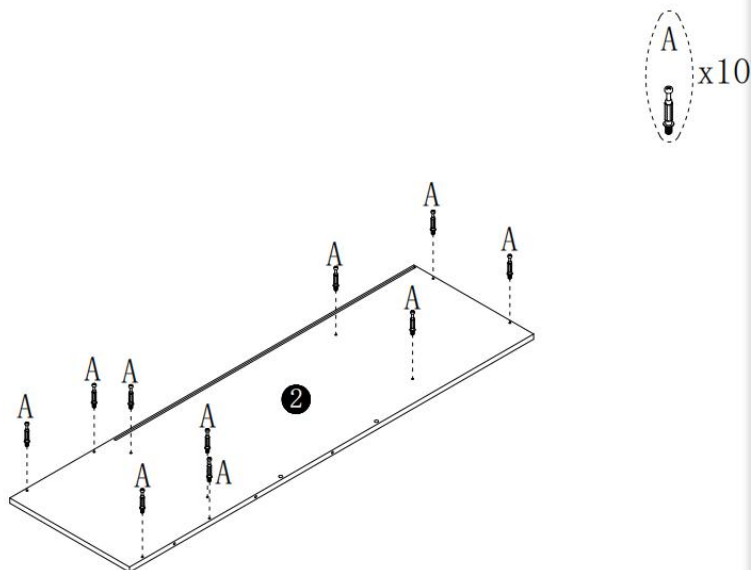

ASSEMBLY STEP

9

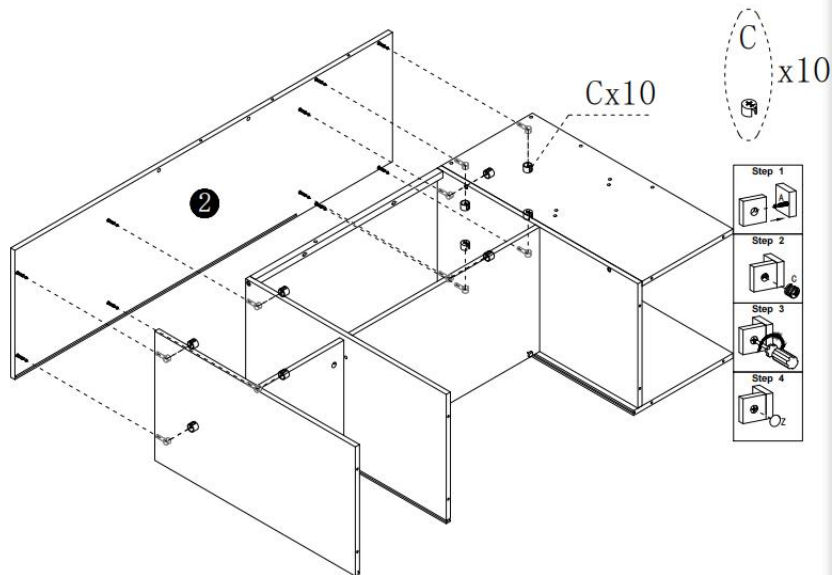

10

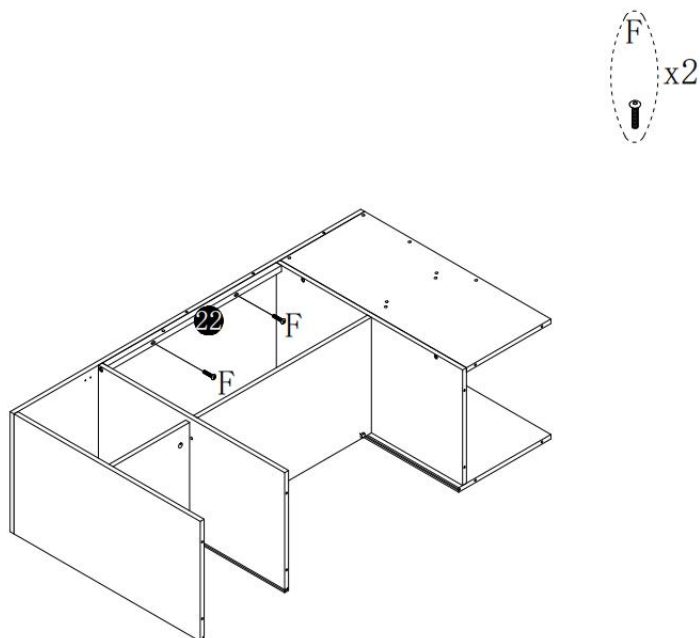

ASSEMBLY STEP

11

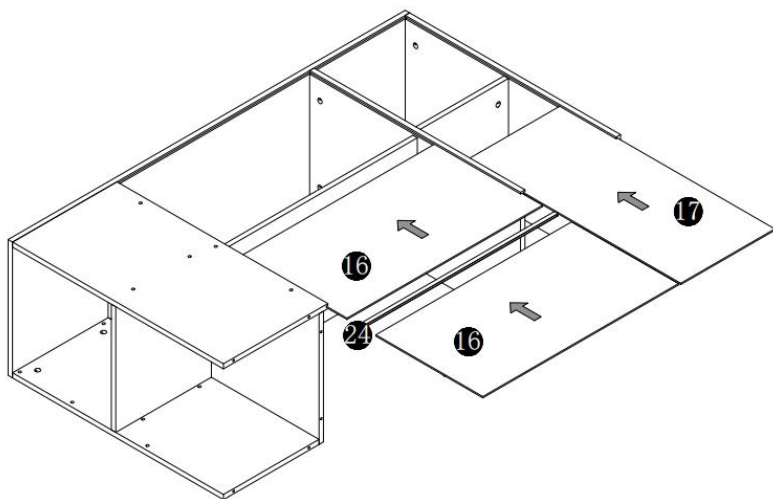

12

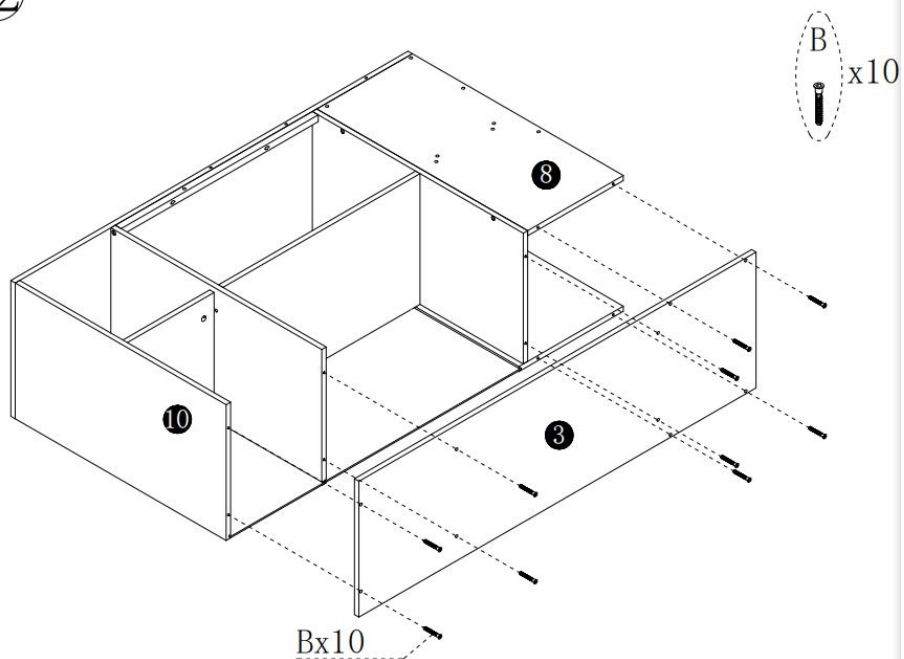

ASSEMBLY STEP

13

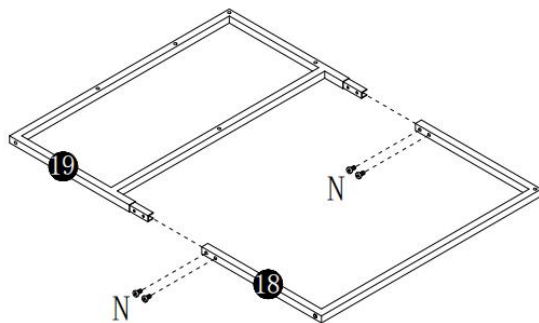
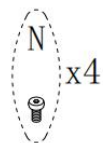

14

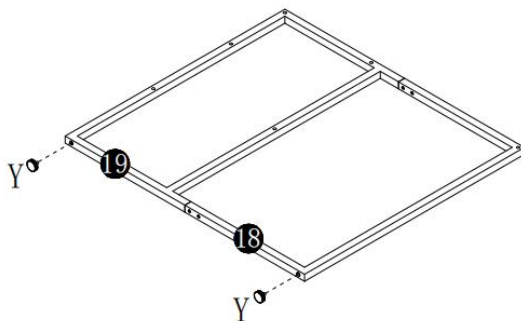
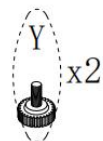

ASSEMBLY STEP

15

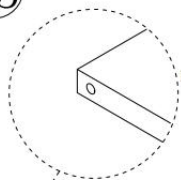

Note: This hole direction

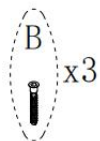
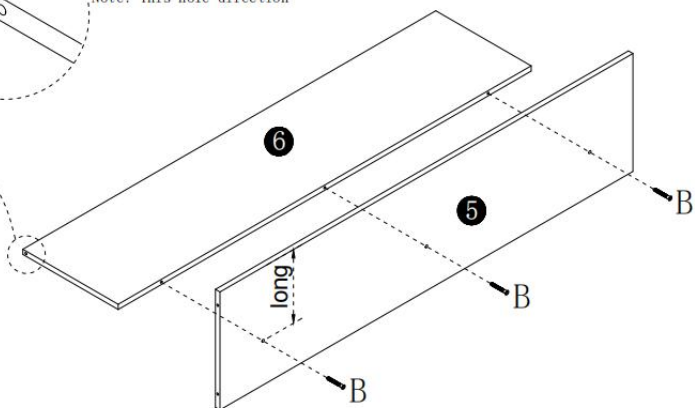

16

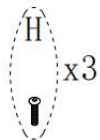
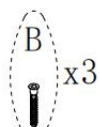
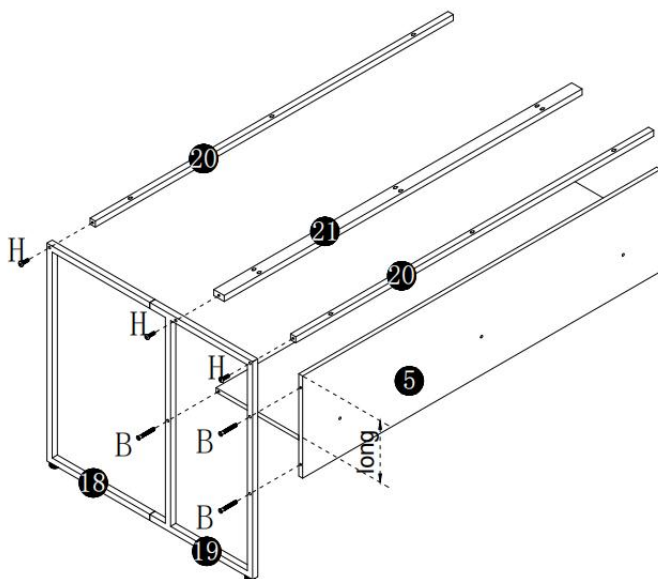

ASSEMBLY STEP

17

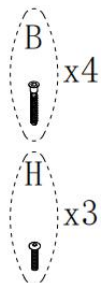
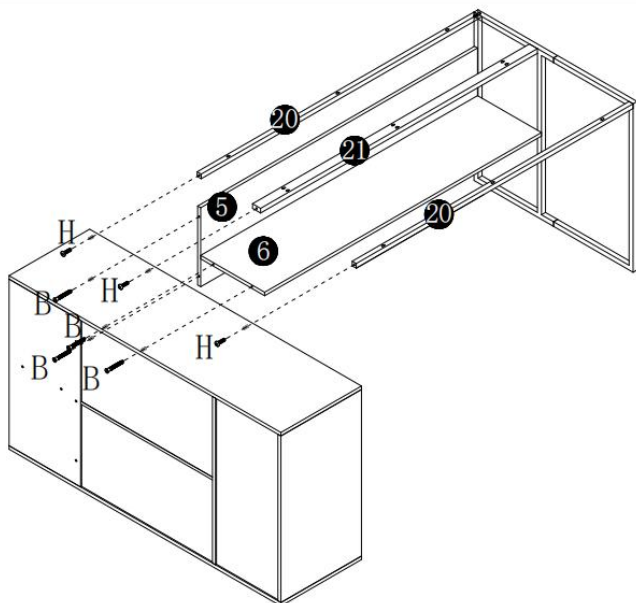

18

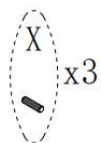
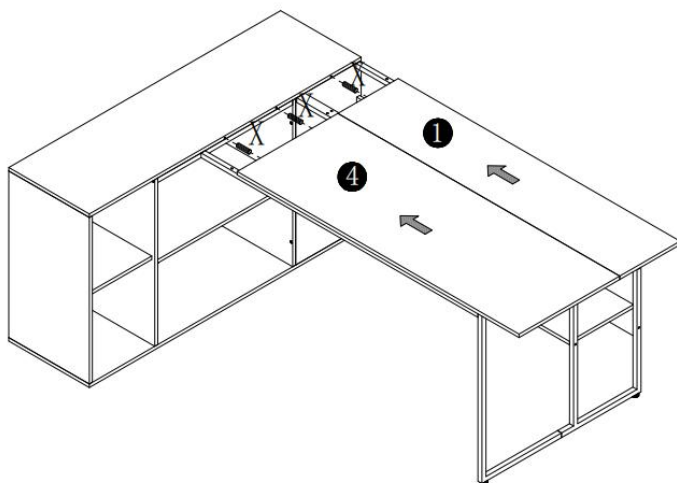

ASSEMBLY STEP

19

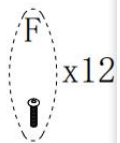
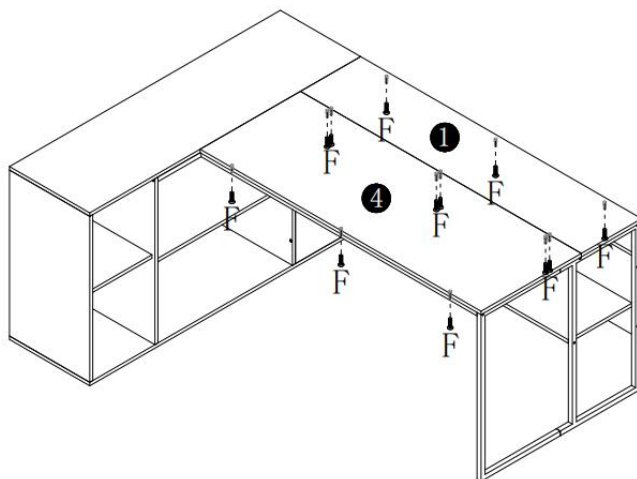

20

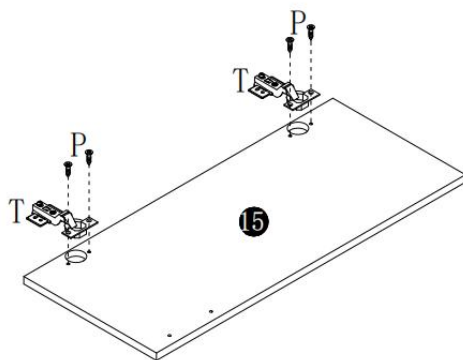

ASSEMBLY STEP

21

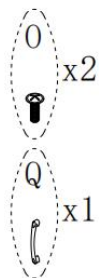
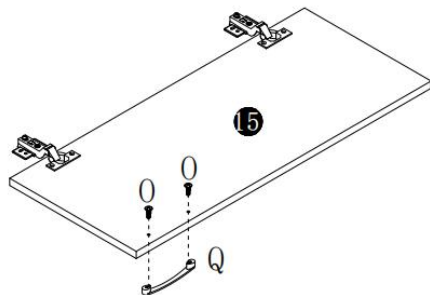

22

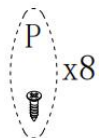
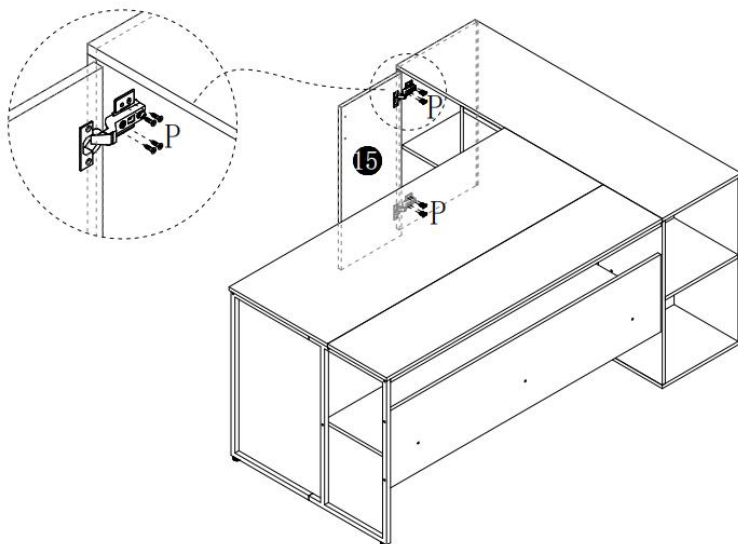

ASSEMBLY STEP

23

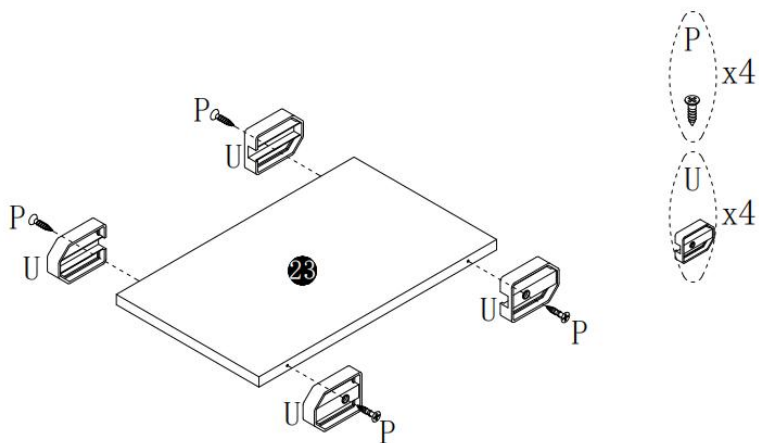

24

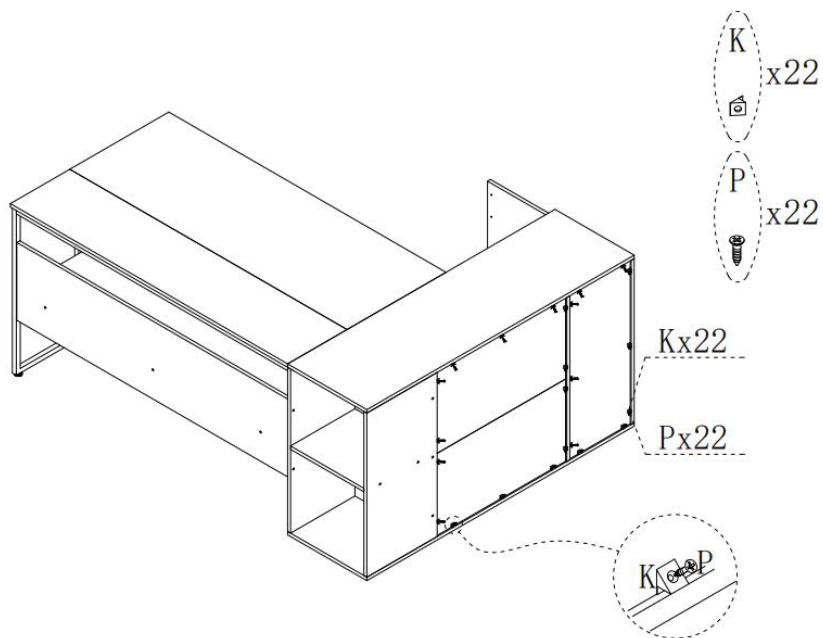

ASSEMBLY STEP

25

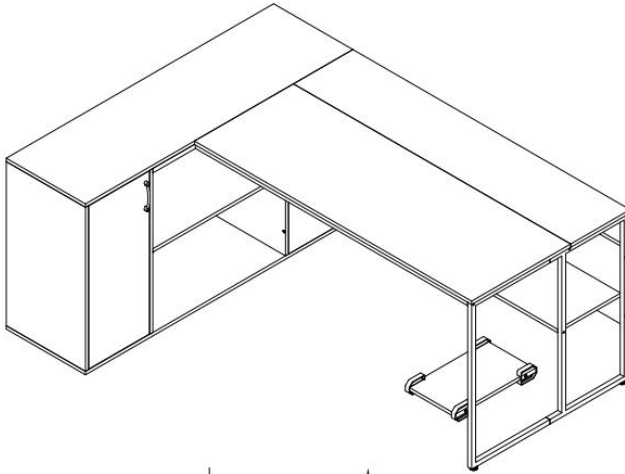

↓
OR
↑

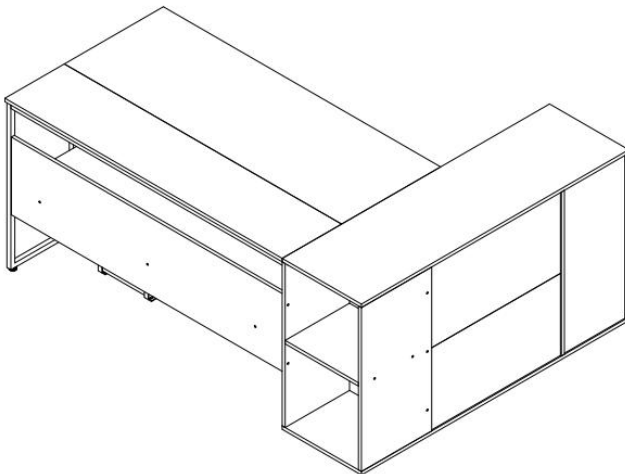

PRODUCT PARAMETER

Model	C250243D-01
Safe Loading Weight	350 lbs
Product Size(D*W*H)	1800*800*750mm

* Products such as specifications, appearance, and design are subject to modification without prior notice.

Manufacturer: Shanghaimuxinmuyeyouxiangongsi

Address: Shuangchenglu 803nong11hao1602A-1609shi, baoshanqu, shanghai 200000 CN.

Imported to AUS: SIHAO PTY LTD. 1 ROKEVA STREETEASTWOOD NSW 2122 Australia

Imported to USA: Sanven Technology Ltd. Suite 250, 9166 Anaheim Place, Rancho Cucamonga, CA 91730

EC	REP
-----------	------------

E-CrossStu GmbH
Mainzer Landstr.69, 60329 Frankfurt am Main.

UK	REP
-----------	------------

YH CONSULTING LIMITED.
C/O YH Consulting Limited Office 147, Centurion House, London Road, Staines-upon-Thames, Surrey, TW18 4AX



VEVOR

Affordable. Reliable. Home Improvement.

BUREAU EXÉCUTIF

MODÈLE: C250243D-01

VEVOR

Affordable. Reliable. Home Improvement.

EXECUTIVE DESK

MODÈLE: C25024 3 D-01

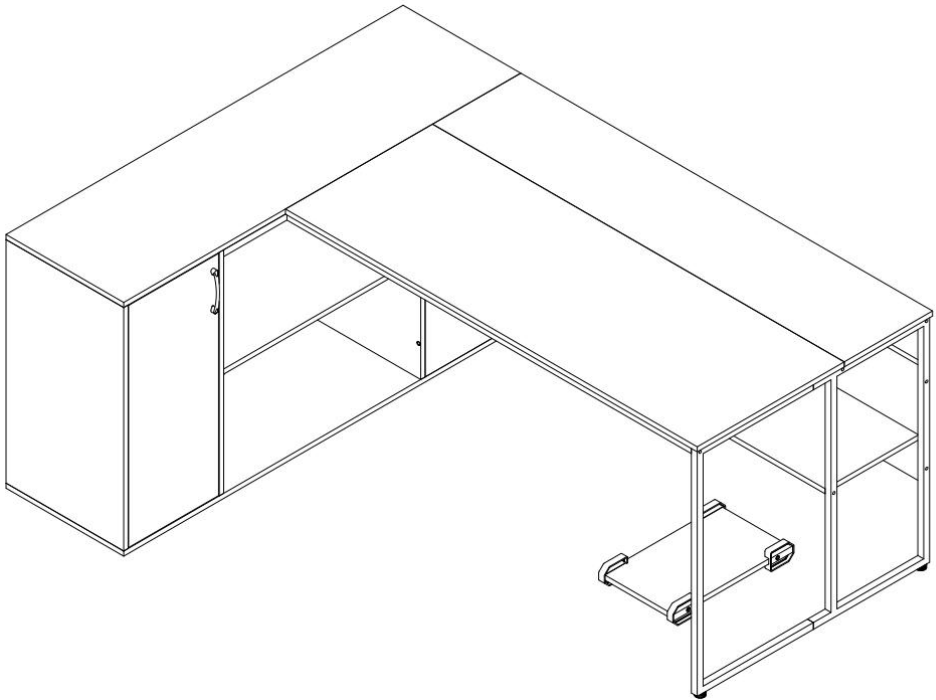

Ceci est le mode d'emploi d'origine. Veuillez lire attentivement l'intégralité du manuel avant utilisation. VEVOR se réserve le droit d'interpréter clairement ce manuel d'utilisation. L'apparence du produit dépend du produit que vous avez reçu. Veuillez nous excuser de ne pas vous informer ultérieurement des mises à jour technologiques ou logicielles de notre produit.

SAFETY INSTRUCTIONS

INTRODUCTION

Merci d'avoir acheté nos produits. Notre engagement à fournir à nos clients des produits et un service de la meilleure qualité a toujours été notre priorité. Avant d'utiliser ce produit, veuillez lire ceci. manuel d'instructions soigneusement pour garantir une utilisation correcte. Conservez le manuel d'instructions dans un endroit où l'utilisateur peut le retrouver à tout moment.

ASSEMBLÉE PRÉCAUTIONS

Il y en a beaucoup composants et accessoires dans l'emballage. Chaque le composant et l'accessoire sont étiquetés avec une lettre ou un numéro, vérifiez soigneusement avant d'utiliser l'un d'entre eux. Gardez-les hors de portée des enfants pour prévenir les accidents.

12. Assembler uniquement conformément à ces instructions. Un assemblage incorrect peut créer des dangers.
13. Portez des lunettes de sécurité approuvées ANSI et des gants de travail robustes pendant l' assemblage.
14. Gardez la zone de montage propre et bien éclairée.
15. Gardez les spectateurs hors de la zone pendant le montage.
16. Ne montez pas si vous êtes fatigué ou sous l'influence de l'alcool, de drogues ou de médicaments.
17. Les capacités du produit s'appliquent uniquement aux produits correctement et entièrement assemblés.
18. Veuillez installer le produit sur une sous-couche propre et douce (comme de la moquette) ou carton) pour éviter de rayer ou d'endommager la surface du produit .
19. Si possible, vous pouvez utiliser des outils électriques pour faciliter le montage.
20. Les principaux composants du produit sont relativement lourds. Veuillez payer attention à la sécurité lors de l'installation .

21. Le produit n'est pas stable lors de l'installation, veuillez ne pas le déplacer au hasard avant qu'il ne soit complètement installé .
22. Pour plus d'informations sur les pièces répertoriées ci-dessous pages, veuillez vous référer au schéma d'assemblage de ce manuel. Déballez et séparez toutes les pièces dans une zone de travail propre.

***ASSUREZ-VOUS DE SUIVRE LES ÉTAPES D'INSTALLATION DANS LE MANUEL POUR ÉVITER LES PERTES INUTILES CAUSÉES PAR UNE MAUVAISE INSTALLATION.**

UTILISER PRÉCAUTIONS







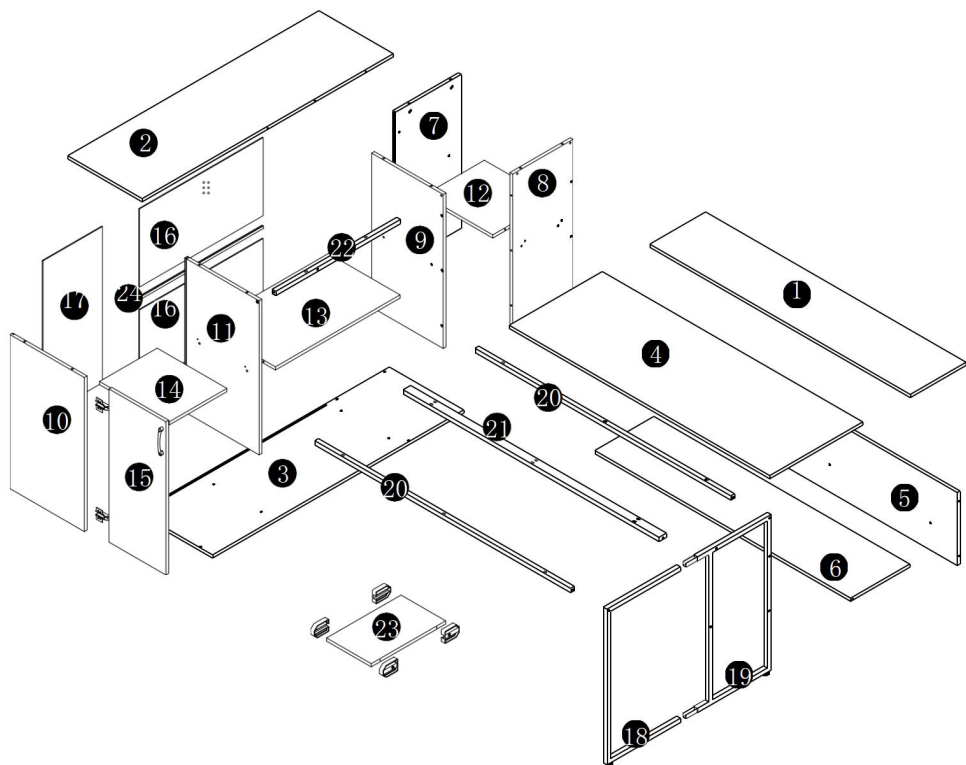







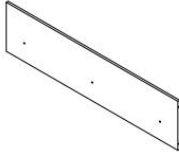

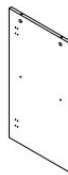

- 5) Ne pas dépasser la dose spécifiée capacités de poids.
- 6) Utiliser uniquement sur une surface plane, de niveau, dure et lisse pouvant supporter en toute sécurité un bureau de direction entièrement chargé.
- 7) Utiliser uniquement comme prévu.
- 8) Inspectez avant chaque utilisation ; ne pas utiliser si des pièces sont desserrées ou endommagées.

CONSERVEZ CE MANUEL



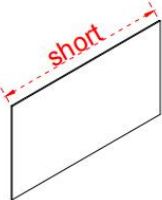
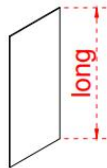

EXPLODED VIEW







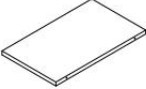







PARTS LIST

 <p>1 1pc</p>	 <p>2 1pc</p>	 <p>3 1pc</p>	 <p>4 1pc</p>
 <p>5 1pc</p>	 <p>6 1pc</p>	 <p>7 1pc</p>	 <p>8 1pc</p>
 <p>9 1pc</p>	 <p>10 1pc</p>	 <p>11 1pc</p>	 <p>12 1pc</p>
 <p>13 1pc</p>	 <p>14 1pc</p>	 <p>15 1pc</p>	 <p>16 2pcs</p>
 <p>17 1pc</p>	 <p>18 1pc</p>	 <p>19 1pc</p>	 <p>20 2pcs</p>

PARTS LIST

 <p>21 1pc</p>	 <p>22 1pc</p>	 <p>23 1pc</p>	 <p>24 1pc</p>
---	--	--	--

 <p>M6X40MM A 14pcs</p>	 <p>M7X50MM B 34pcs</p>	 <p>C 14pcs</p>	 <p>M6X30MM F 14pcs</p>	 <p>M6X40MM H 8pcs</p>
 <p>K 22pcs</p>	 <p>M6X10MM N 4pcs</p>	 <p>M4X18MM O 2pcs</p>	 <p>ST3. 5X12MM P 38pcs</p>	 <p>Q 1pc</p>
 <p>DWX15MM T 2pcs</p>	 <p>U 4pcs</p>	 <p>X 3pcs</p>	 <p>M8X14MM Y 2pcs</p>	 <p>1pc</p>
				

ASSEMBLY STEP

Installation de cames et de broches

Vissez la goupille dans le trou. Pour régler correctement les cames, assurez-vous que la flèche de la came s'ouvre vers le trou de la goupille qu'elle verrouille. Verrouillez la came en tournant la tête de came avec un tournevis jusqu'à ce qu'elle soit serrée. N'utilisez pas de tournevis électrique pour assembler les cames. unité.

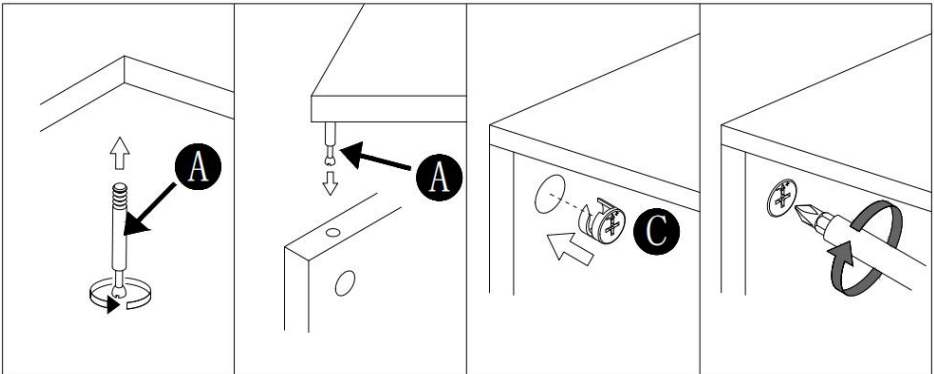

Lisez attentivement chaque étape avant de commencer. Il est très important que chaque étape des instructions soit effectuée dans le bon ordre. Si ces étapes ne sont pas suivies dans l'ordre, des difficultés d'assemblage surviendront. se produire.

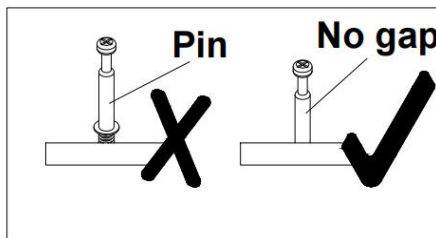

ASSEMBLY STEP

1

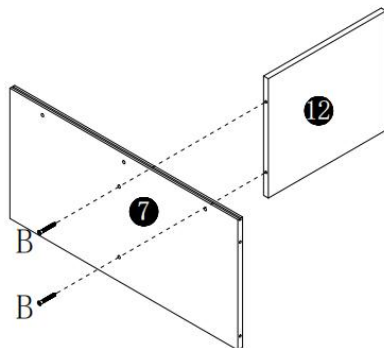
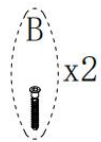

2

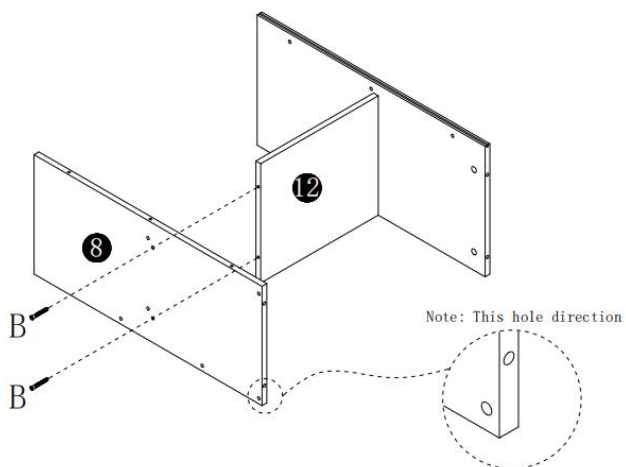
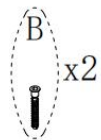

ASSEMBLY STEP

3

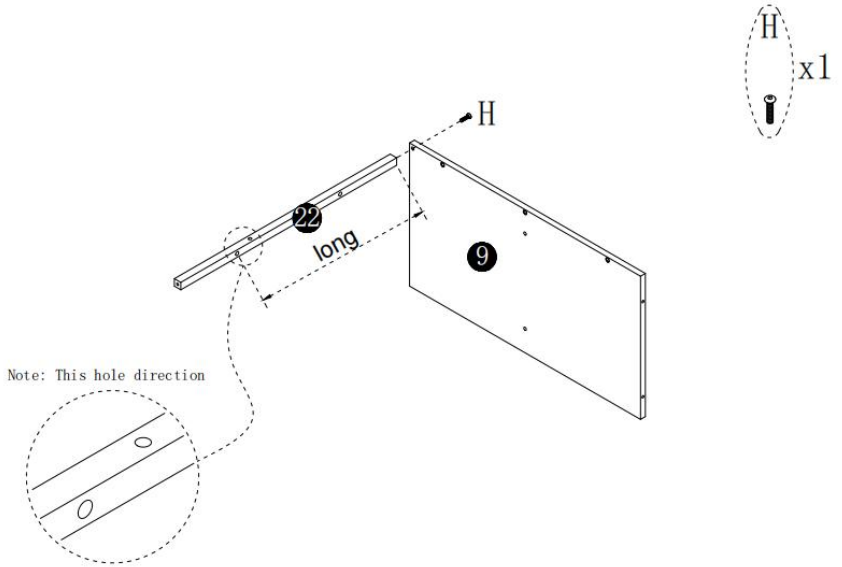

4

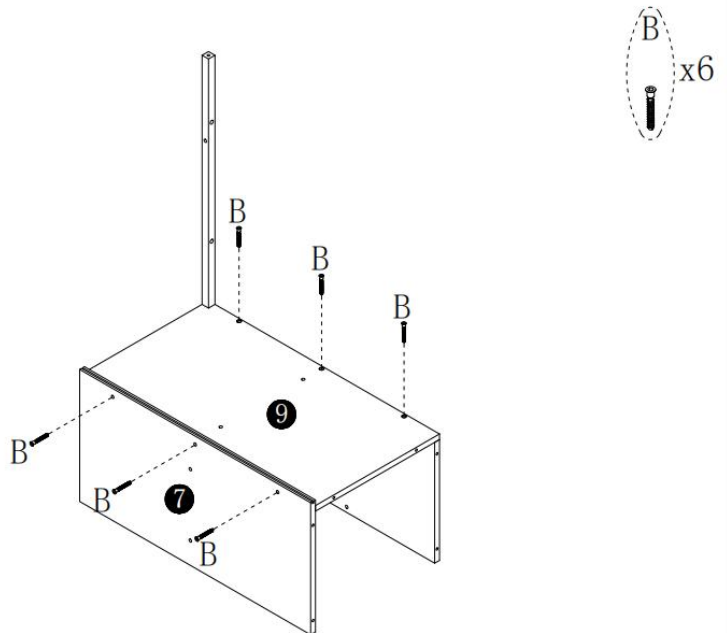

ASSEMBLY STEP

5

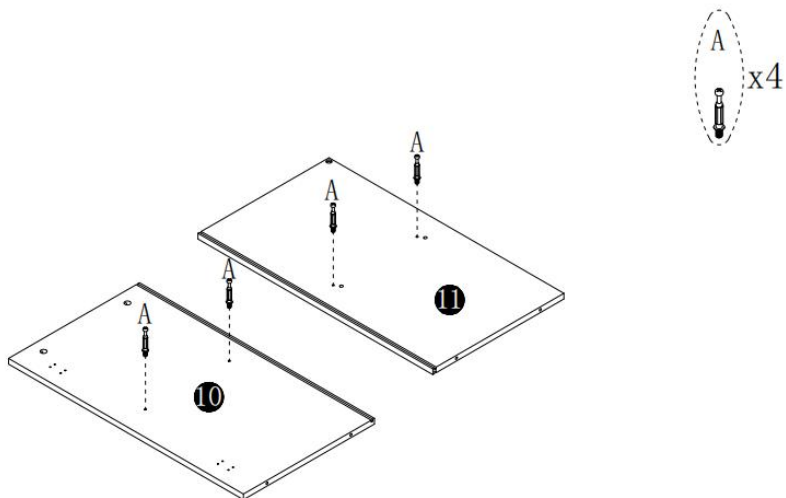

6

Note: This hole direction

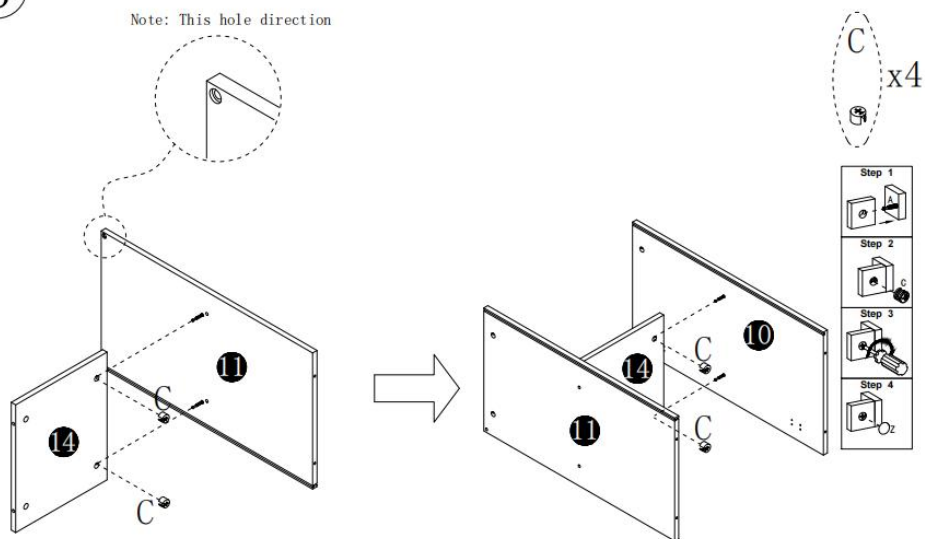

ASSEMBLY STEP

7

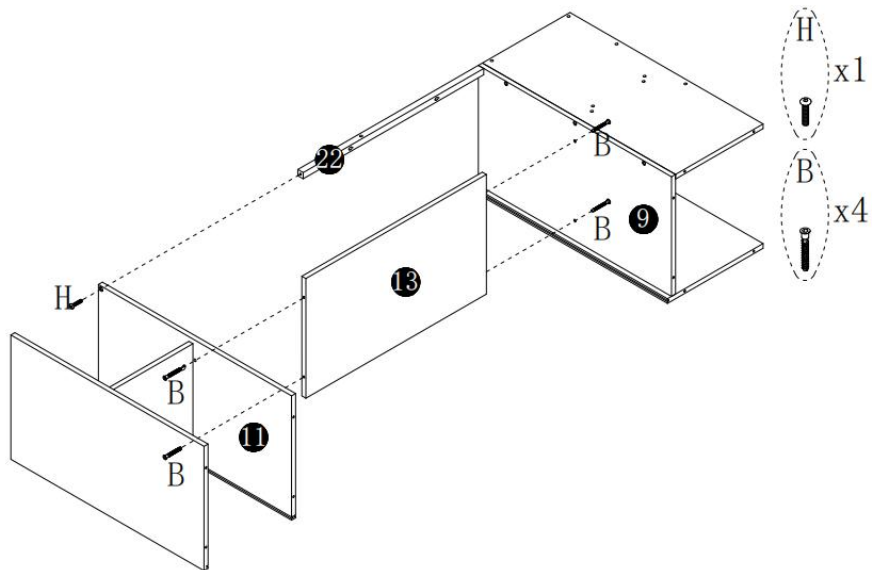

8

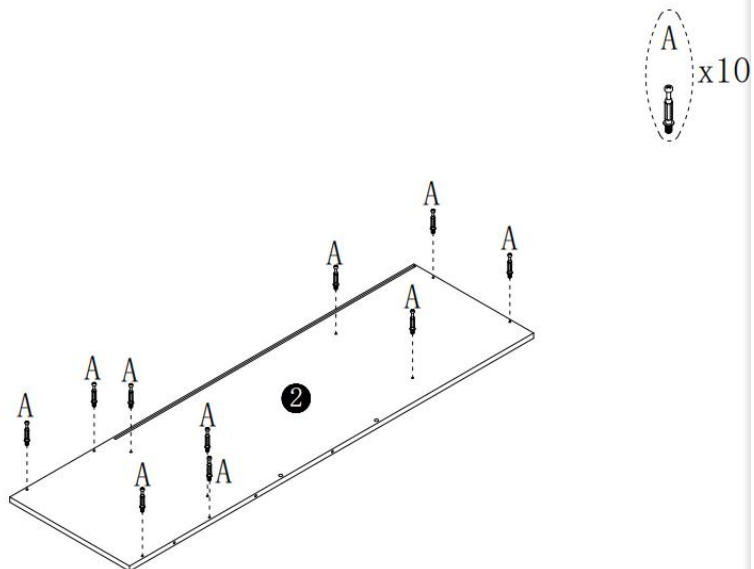

ASSEMBLY STEP

9

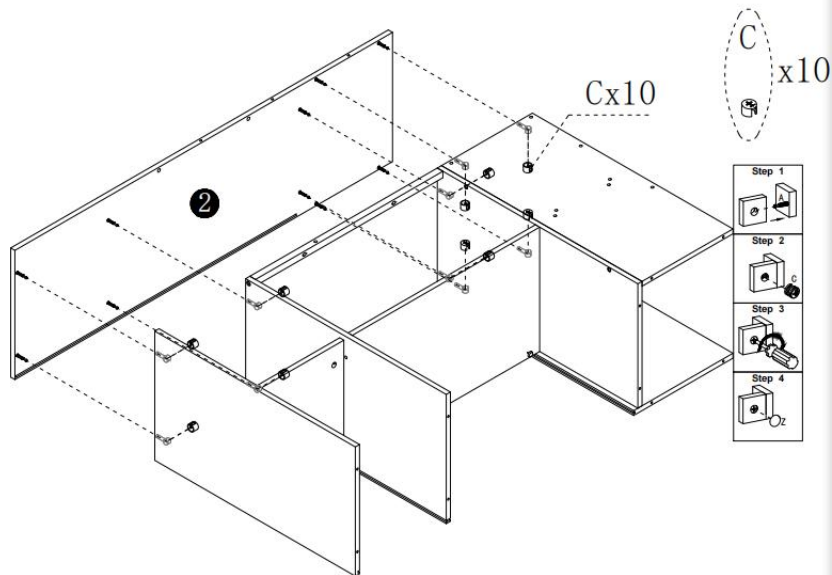

10

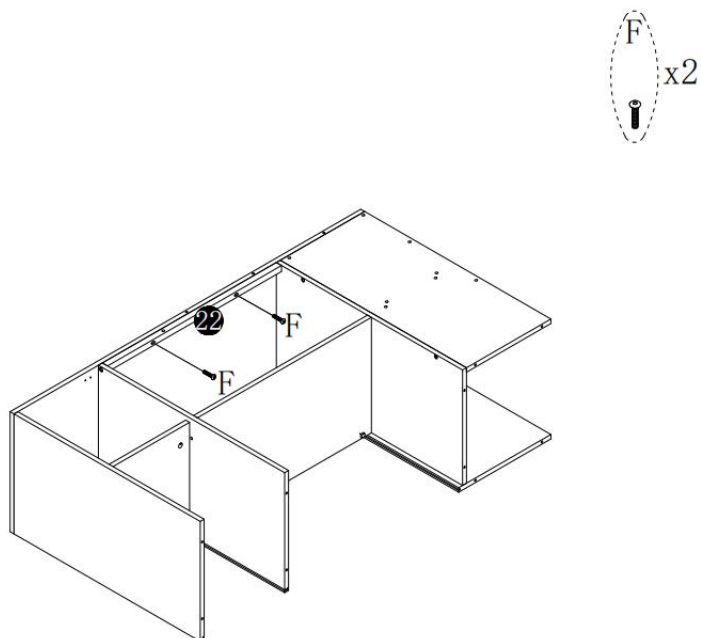

ASSEMBLY STEP

11

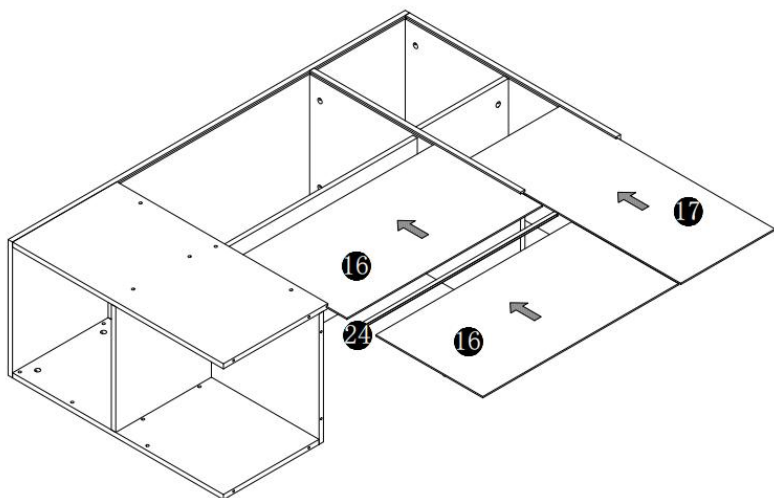

12

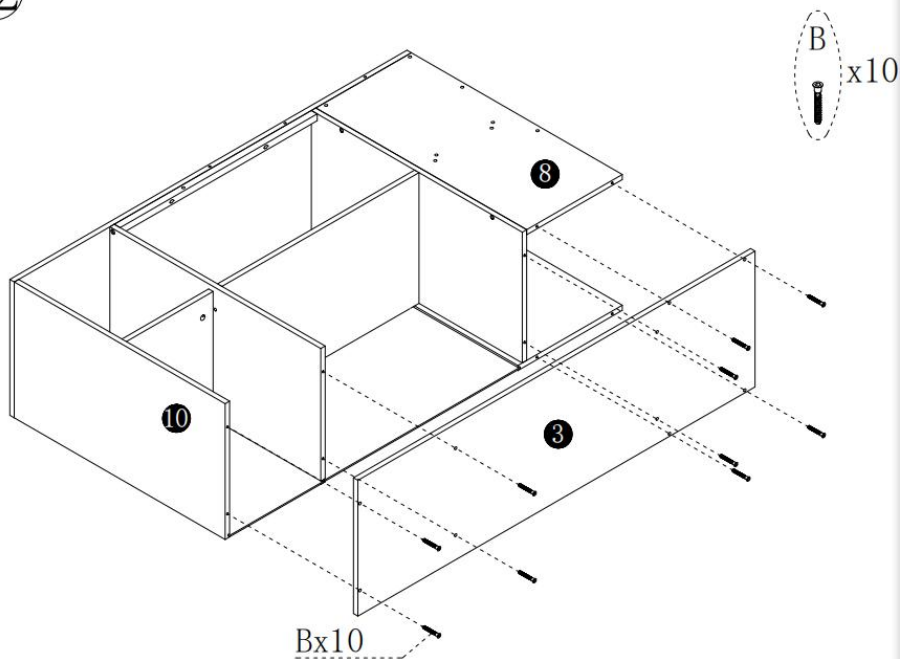

ASSEMBLY STEP

13

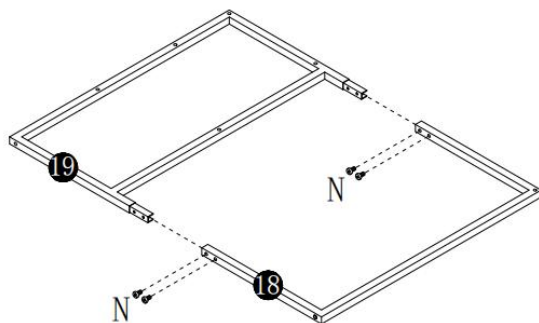
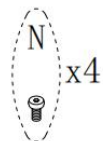

14

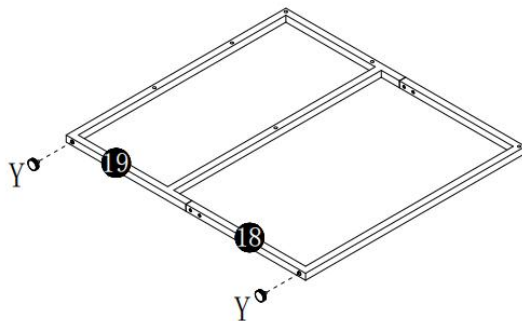
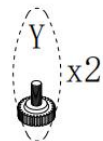

ASSEMBLY STEP

15

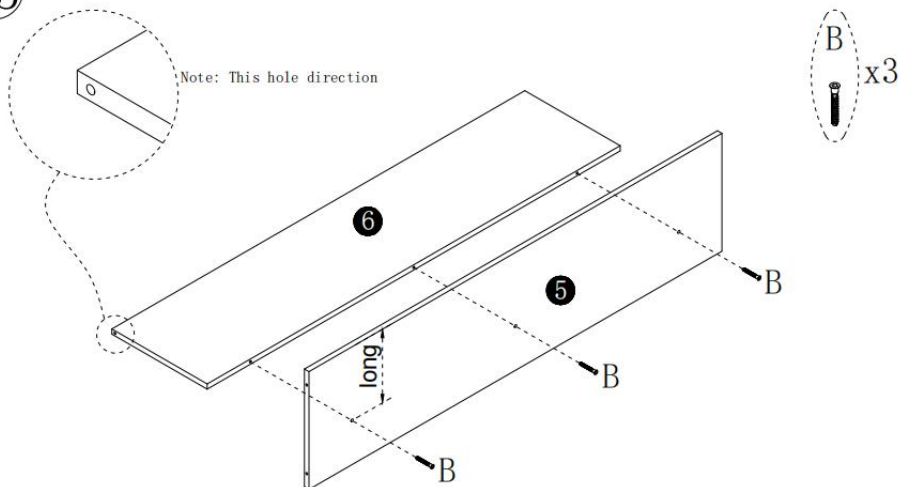

16

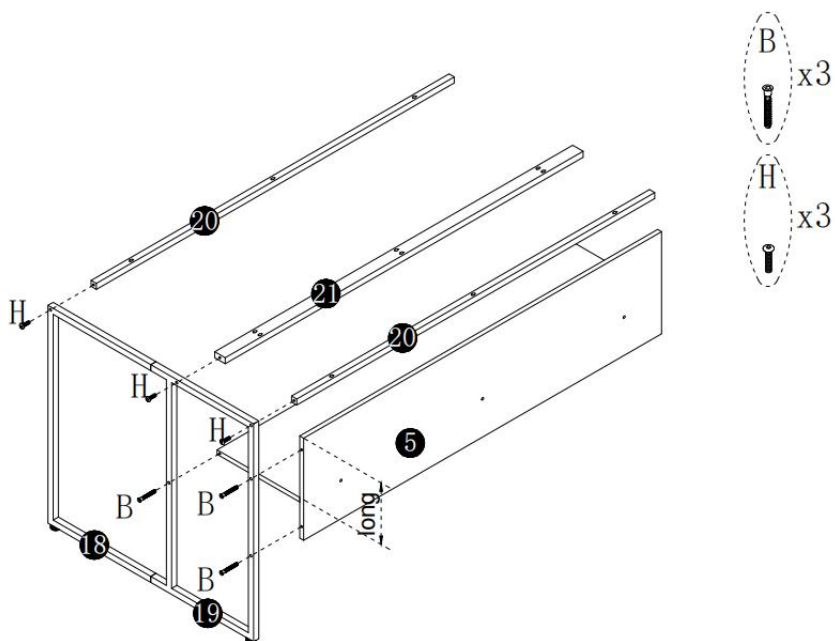

ASSEMBLY STEP

17

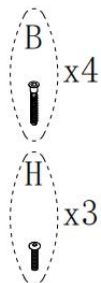
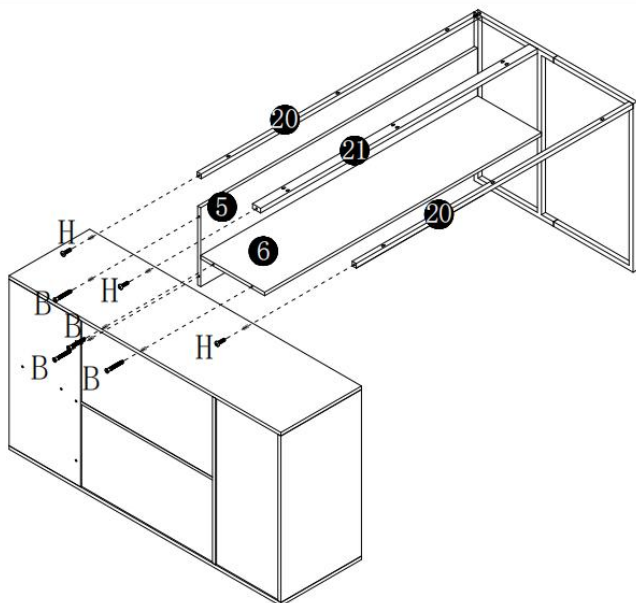

18

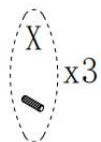
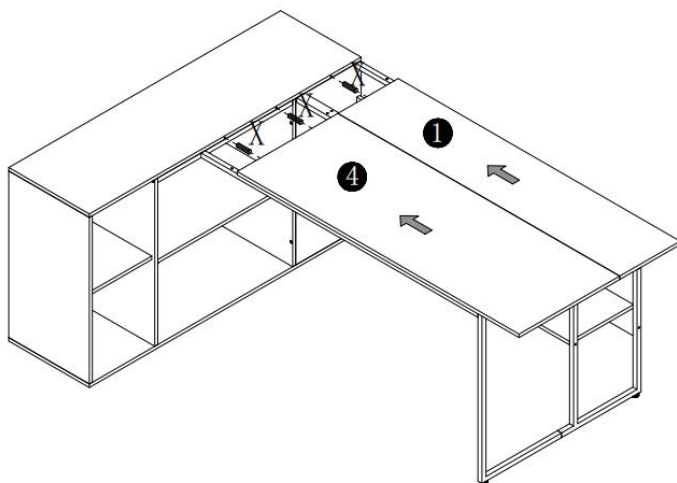

ASSEMBLY STEP

19

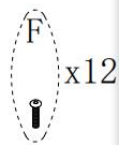
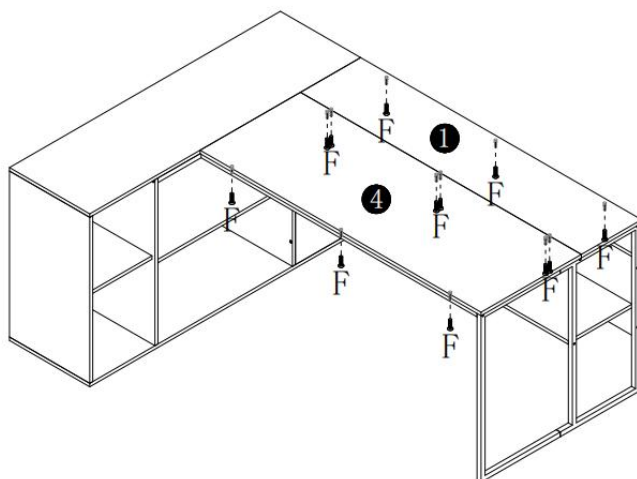

20

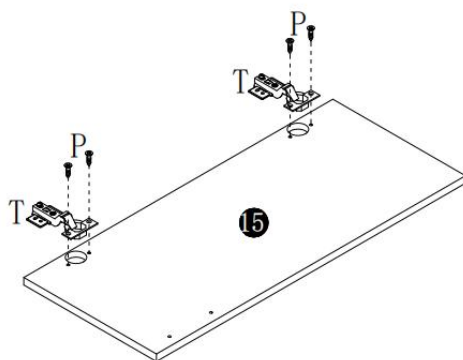

ASSEMBLY STEP

21

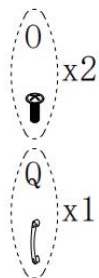
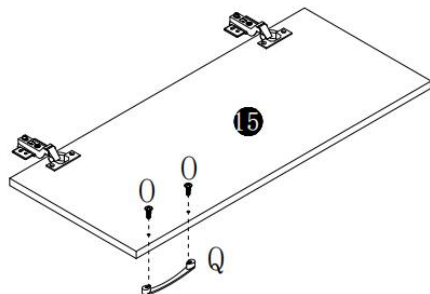

22

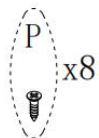
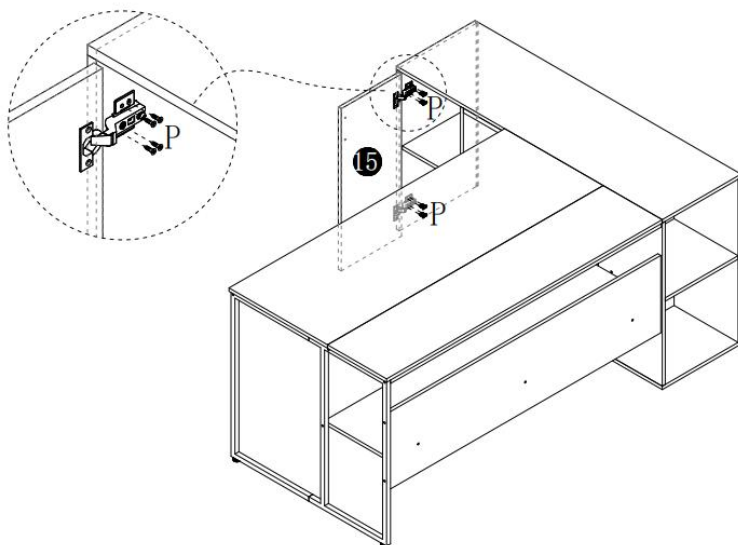

543

ASSEMBLY STEP

23

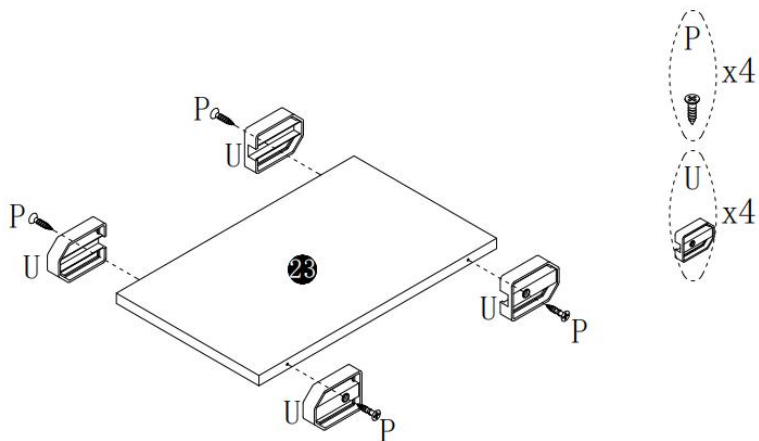

24

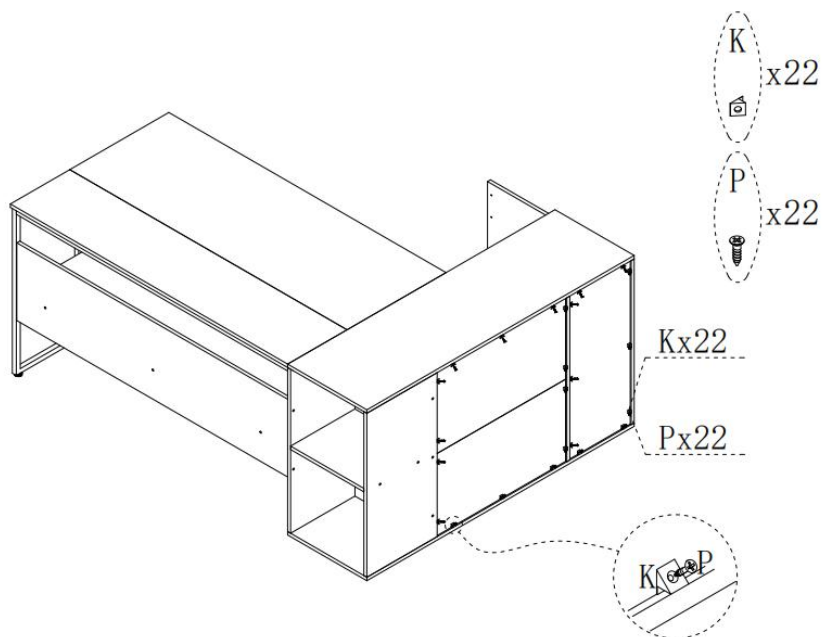

ASSEMBLY STEP

25

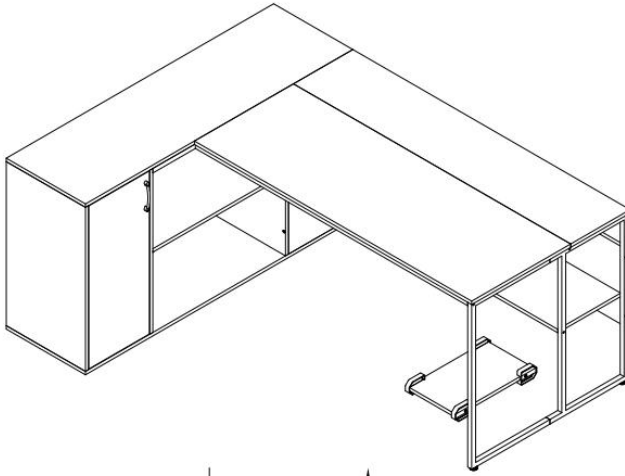

↓
OR
↑

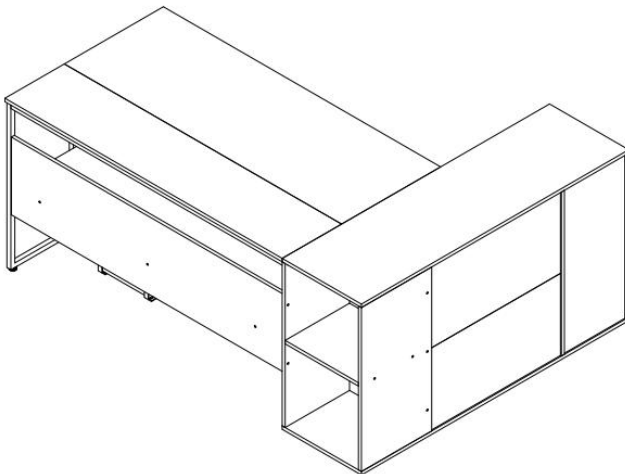

PRODUCT PARAMETER

Modèle	C25024 3 D-01
Poids de chargement sécuritaire	350 livres
Dimensions du produit (P*L*H)	1 8 00* 80 0* 75 0 mm

* Les produits tels que les spécifications, l'apparence et la conception sont sujets à modification sans préavis.

Fabricant : Shanghaimuxinmuyeyouxiangongsi

Adresse : Shuangchenglu 803nong11hao1602A-1609shi, baoshanqu, shanghai 200000 CN.

Importé en Australie : SIHAO PTY LTD. 1 ROKEVA STREET, ASTWOOD, NSW 2122, Australie

Importé aux États-Unis : Sanven Technology Ltd. Suite 250, 9166 Anaheim Place, Rancho Cucamonga, CA 91730

EC	REP
-----------	------------

E-CrossStu GmbH
Mainzer Landstr.69, 60329 Frankfurt am Main.

UK	REP
-----------	------------

YH CONSULTING LIMITED.
C/O YH Consulting Limited Office 147, Centurion House, London Road, Staines-upon-Thames, Surrey, TW18 4AX



VEVOR

Affordable. Reliable. Home Improvement.

CHEFSCHREIBTISCH

MODELL: C250243D-01

VEVOR

Affordable. Reliable. Home Improvement.

EXECUTIVE DESK

MODELL: C25024 3 D-01

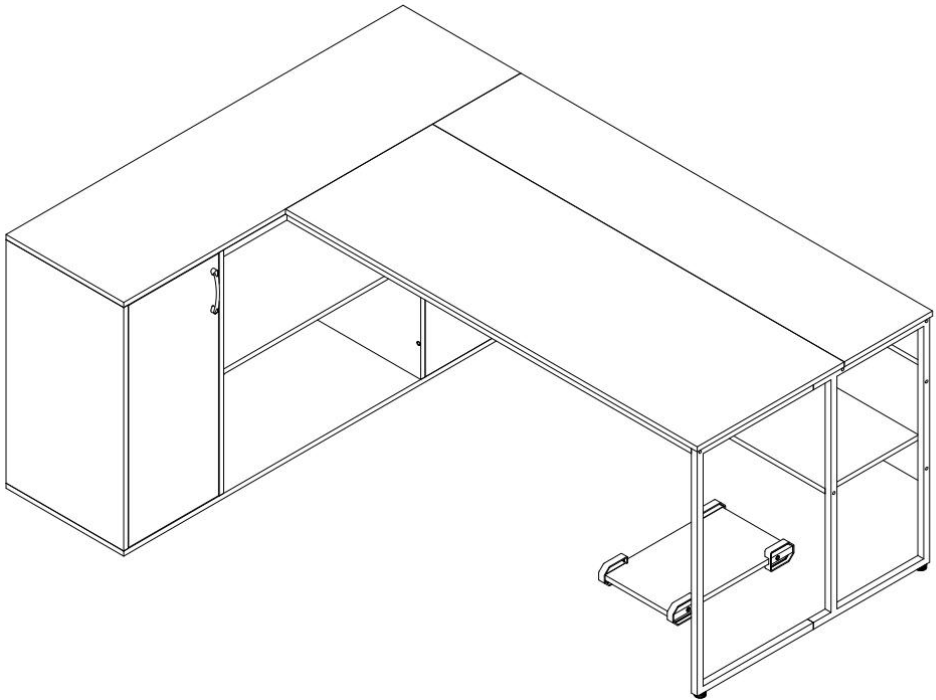

Dies ist die Originalanleitung. Bitte lesen Sie alle Anweisungen sorgfältig durch, bevor Sie das Gerät in Betrieb nehmen. VEVOR behält sich eine klare Auslegung unserer Bedienungsanleitung vor. Das Aussehen des Produkts hängt vom gelieferten Produkt ab. Bitte haben Sie Verständnis dafür, dass wir Sie nicht erneut über Technologie- oder Software-Updates informieren.

SAFETY INSTRUCTIONS

EINFÜHRUNG

Vielen Dank für den Kauf unserer Produkte. Unser Ziel ist es, unseren Kunden Produkte und Dienstleistungen von höchster Qualität zu bieten. Bitte lesen Sie vor der Verwendung des Produkts diese Bedienungsanleitung sorgfältig, um eine korrekte Verwendung zu gewährleisten. Bewahren Sie die Bedienungsanleitung an einem wo der Benutzer es jederzeit finden kann.

MONTAGE VORSICHTSMASSNAHMEN

Es gibt viele Komponenten und Zubehör im Paket. Jeder Komponente und Zubehör mit einem Buchstaben oder einer Zahl gekennzeichnet ist, überprüfen Lesen Sie diese sorgfältig durch, bevor Sie sie verwenden. Bewahren Sie sie außerhalb der Reichweite von Kindern auf, Unfälle verhindern.

23. Führen Sie die Montage ausschließlich gemäß dieser Anleitung durch. Eine unsachgemäße Montage kann zu Gefahren führen.
24. Tragen Sie während der Montage eine ANSI-zugelassene Schutzbrille und strapazierfähige Arbeitshandschuhe.
25. Halten Sie den Versammlungsbereich sauber und gut beleuchtet.
26. Halten Sie während der Montage unbeteiligte Personen vom Bereich fern.
27. Nicht zusammenbauen, wenn Sie müde sind oder unter dem Einfluss von Alkohol, Drogen oder Medikamenten stehen.
28. Die Produkteigenschaften gelten nur für ordnungsgemäß und vollständig montierte Produkte.
29. Bitte installieren Sie das Produkt auf einer sauberen und weichen Unterlage (z. B. Teppich oder Pappe), um Kratzer oder Beschädigungen der Oberfläche des Produkt .
30. Um die Montage zu erleichtern, können Sie nach Möglichkeit Elektrowerkzeuge verwenden.
31. Die Hauptkomponenten des Produkts sind relativ schwer. Bitte zahlen

Sie Achten Sie bei der Installation auf die Sicherheit .

32. Das Produkt ist während der Installation nicht stabil. Bitte bewegen Sie es nicht willkürlich. bevor es vollständig installiert ist .

33. Weitere Informationen zu den im Folgenden aufgeführten Teilen finden Sie

Seiten finden Sie im Montagediagramm dieses Handbuchs.

Auspacken und trennen Sie alle Teile in einem sauberen Arbeitsbereich.

***BITTE BEFOLGEN SIE DIE INSTALLATIONSSCHRITTE IM HANDBUCH, UM VERMEIDEN SIE UNNÖTIGE VERLUSTE DURCH UNSACHGEMÄSSE INSTALLATION.**

VERWENDEN VORSICHTSMASSNAHMEN

9) Überschreiten Sie nicht die angegebene Gewichtskapazitäten.

10) Nur auf einer flachen, ebenen, harten und glatten Oberfläche verwenden, die einen voll beladenen Chefschreibtisch sicher tragen kann.

11) Nur bestimmungsgemäß verwenden.







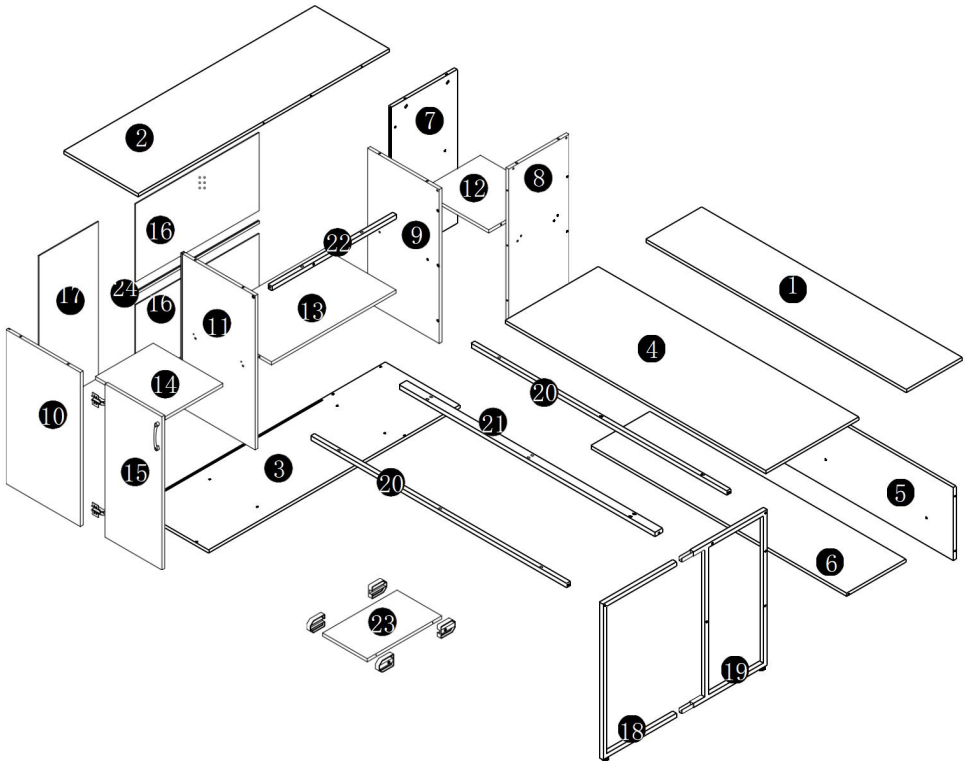







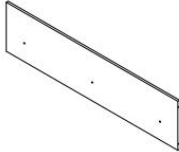

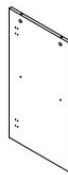

12) Vor jedem Gebrauch prüfen; nicht verwenden, wenn Teile lose oder beschädigt sind.

BEWAHREN SIE DIESES HANDBUCH AUF



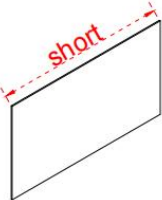
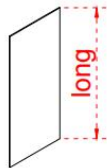

EXPLODED VIEW



















PARTS LIST

 <p>1 1pc</p>	 <p>2 1pc</p>	 <p>3 1pc</p>	 <p>4 1pc</p>
 <p>5 1pc</p>	 <p>6 1pc</p>	 <p>7 1pc</p>	 <p>8 1pc</p>
 <p>9 1pc</p>	 <p>10 1pc</p>	 <p>11 1pc</p>	 <p>12 1pc</p>
 <p>13 1pc</p>	 <p>14 1pc</p>	 <p>15 1pc</p>	 <p>16 2pcs</p>
 <p>17 1pc</p>	 <p>18 1pc</p>	 <p>19 1pc</p>	 <p>20 2pcs</p>

PARTS LIST

			
21 1pc	22 1pc	23 1pc	24 1pc

 M6X40MM A 14pcs	 M7X50MM B 34pcs	 C 14pcs	 M6X30MM F 14pcs	 M6X40MM H 8pcs
 K 22pcs	 M6X10MM N 4pcs	 M4X18MM O 2pcs	 ST3. 5X12MM P 38pcs	 Q 1pc
 DWX15MM T 2pcs	 U 4pcs	 X 3pcs	 M8X14MM Y 2pcs	 1pc
				

Installation von Nocken und Stiften

Schrauben Sie den Stift in die Bohrung. Um die Nocken korrekt einzustellen, achten Sie darauf, dass der Pfeil auf der Nocke zur Bohrung des Stifts zeigt, den sie verriegelt. Verriegeln Sie die Nocke, indem Sie den Nockenkopf mit einem Schraubendreher drehen, bis er fest sitzt. Bitte verwenden Sie keinen Akkuschauber zur Montage. Einheit.

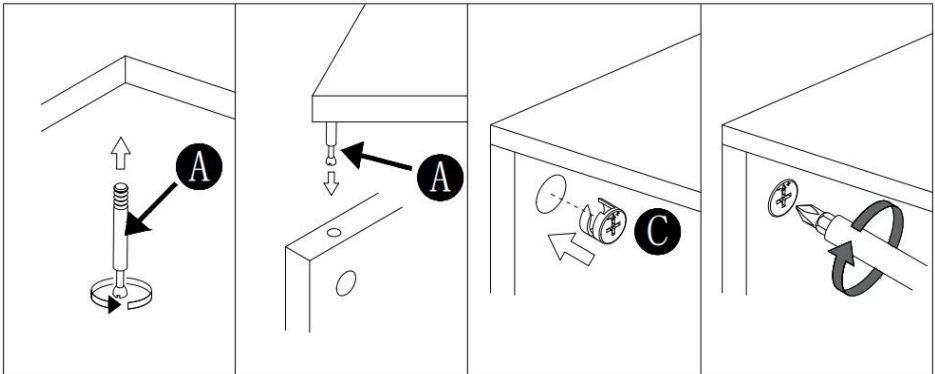

Lesen Sie jeden Schritt sorgfältig durch, bevor Sie beginnen. Es ist sehr wichtig, dass jeder Schritt der Anleitung in der richtigen Reihenfolge ausgeführt wird. Wenn diese Schritte nicht in der richtigen Reihenfolge ausgeführt werden, kann es zu Montageschwierigkeiten kommen. auftreten.!

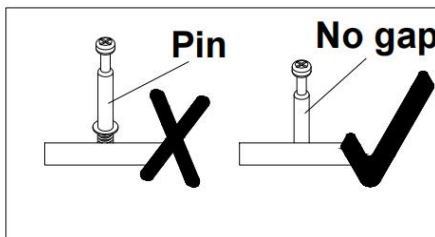

ASSEMBLY STEP

1

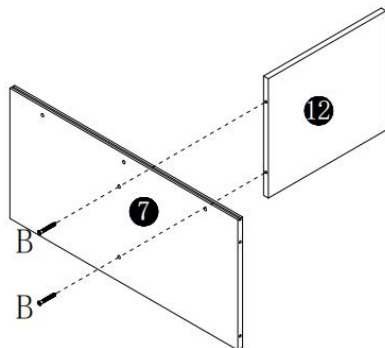
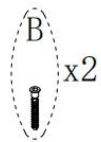

2

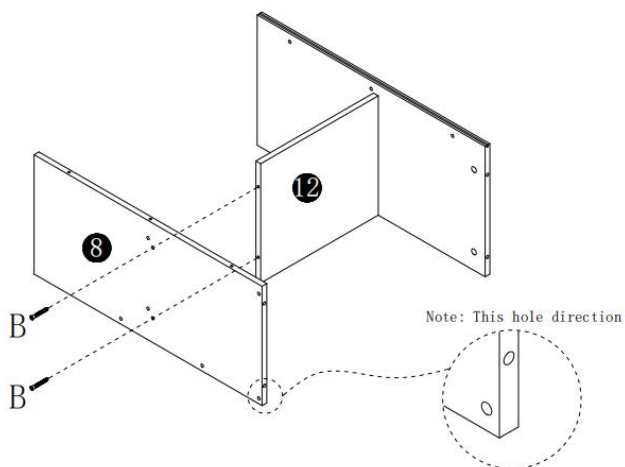
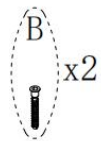

ASSEMBLY STEP

3

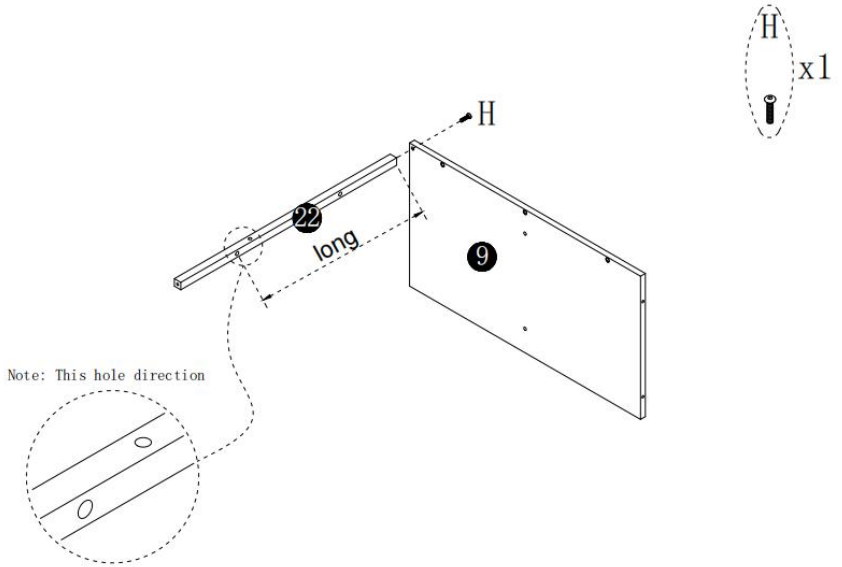

4

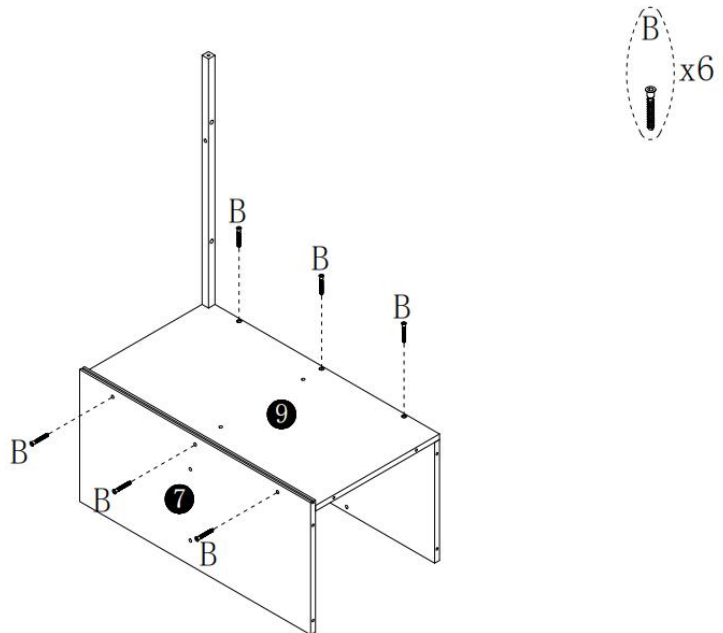

ASSEMBLY STEP

5

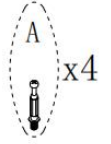
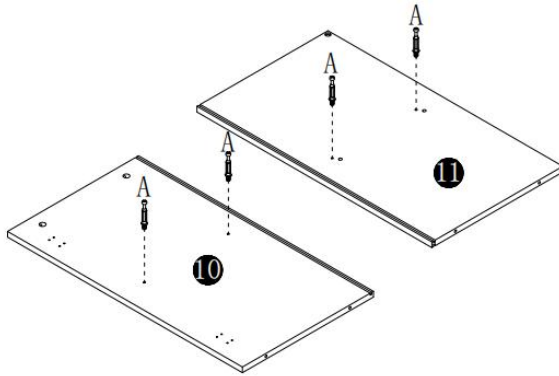

6

Note: This hole direction

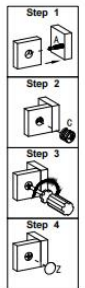
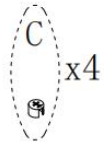
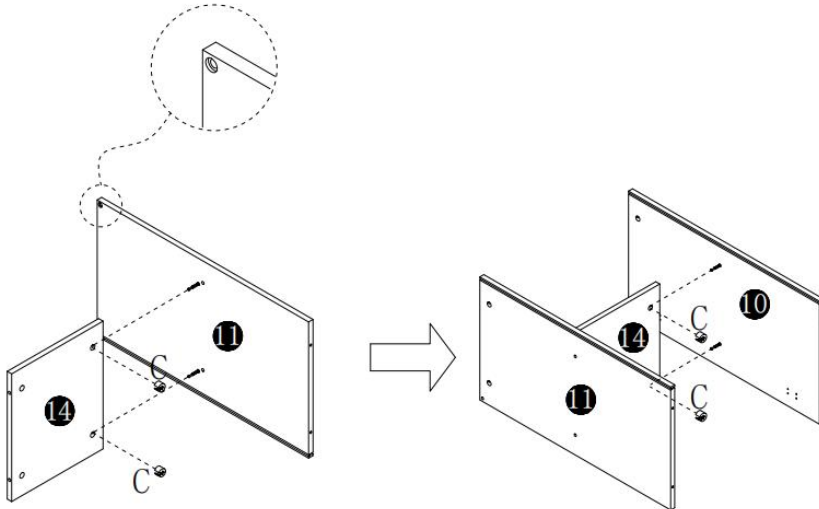

ASSEMBLY STEP

7

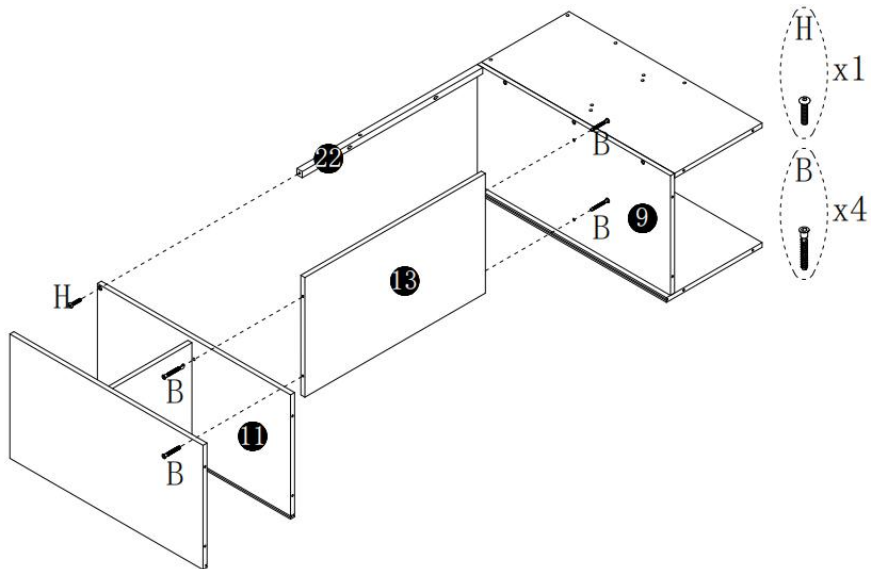

8

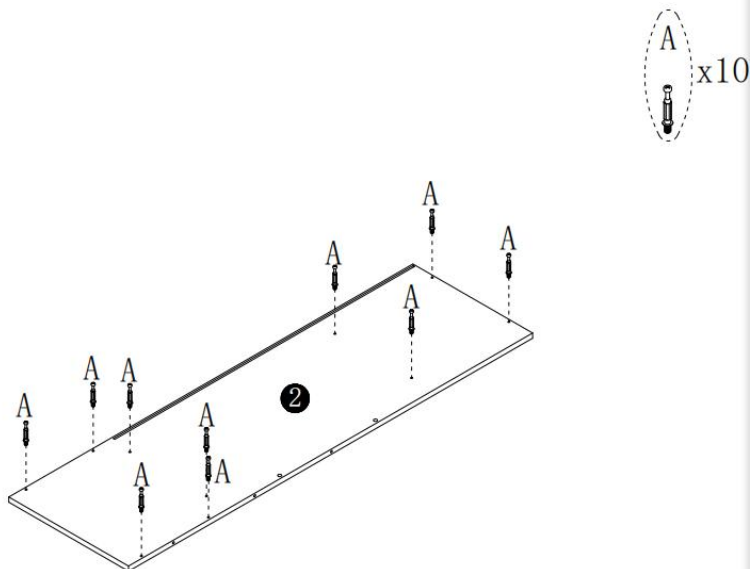

ASSEMBLY STEP

9

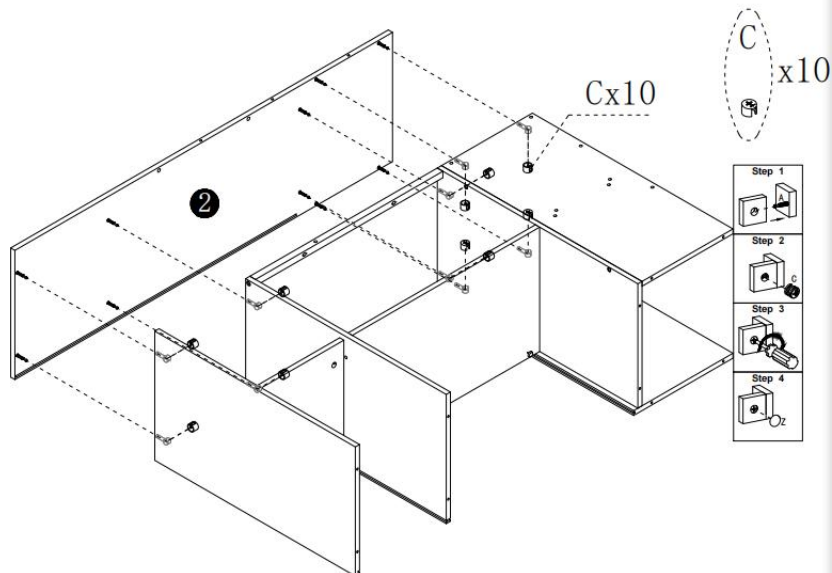

10

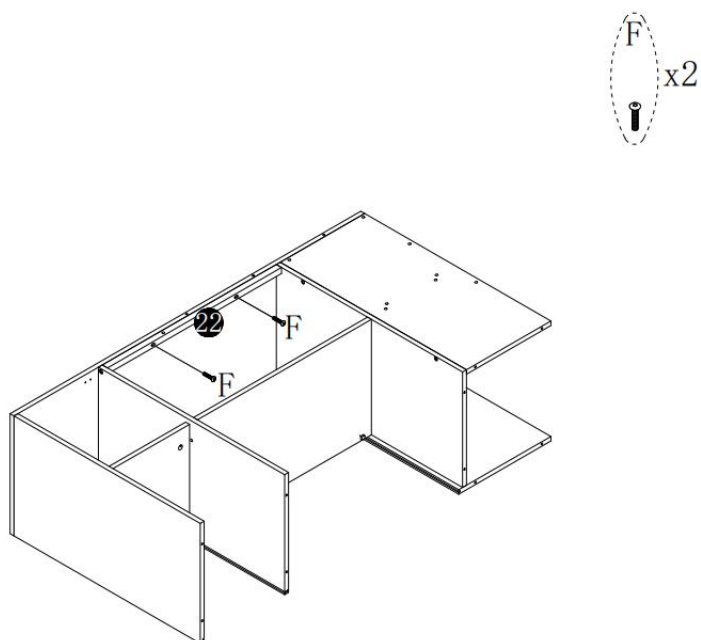

ASSEMBLY STEP

11

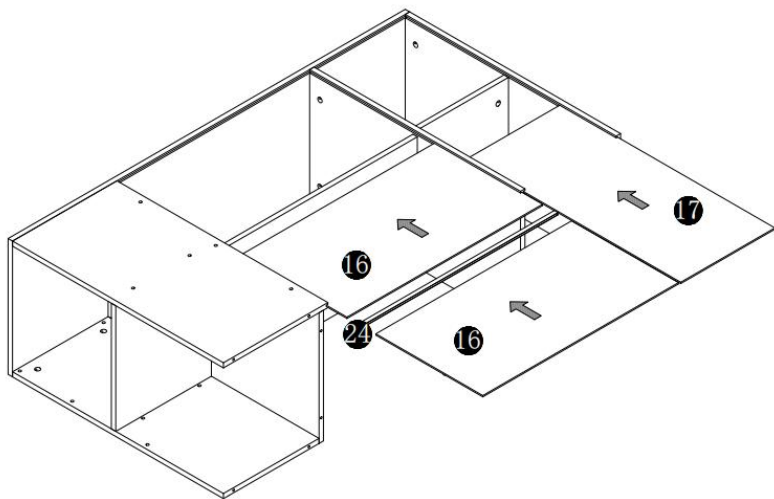

12

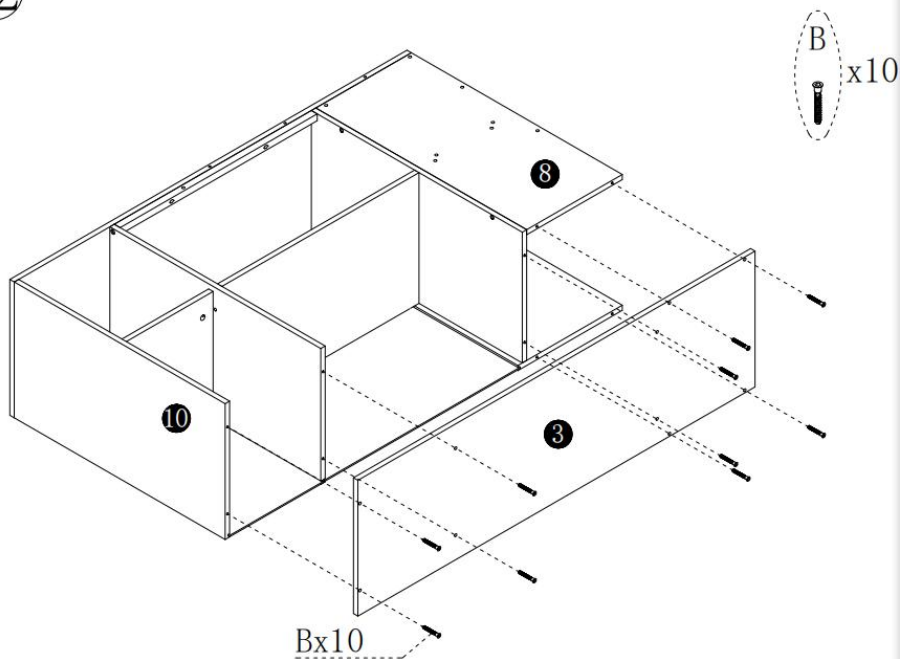

ASSEMBLY STEP

13

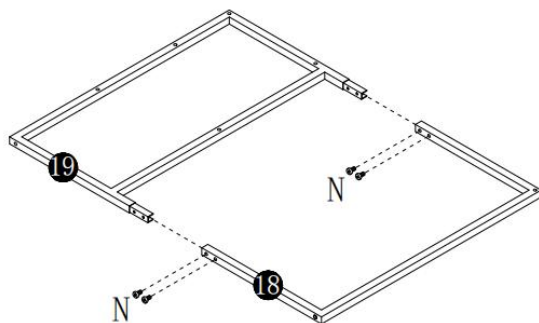
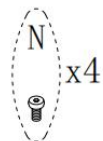

14

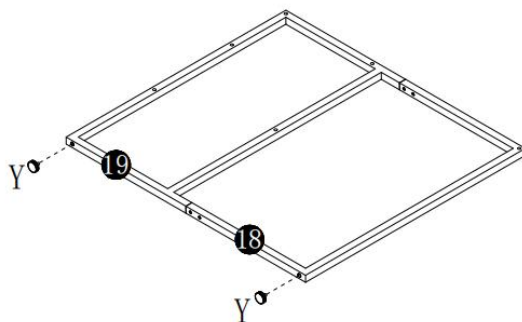
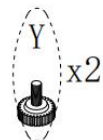

ASSEMBLY STEP

15

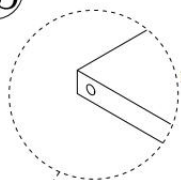

Note: This hole direction

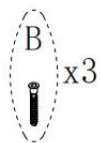
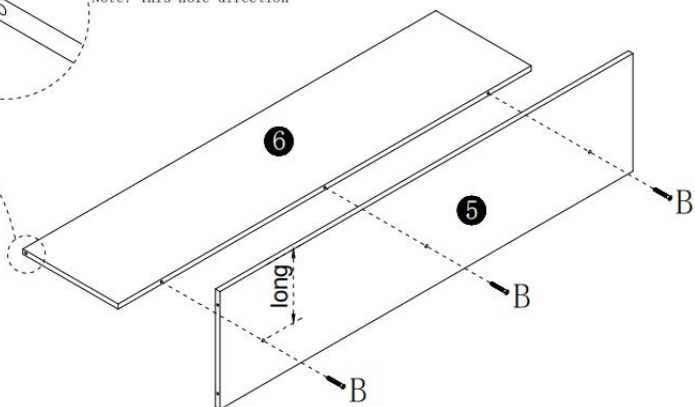

16

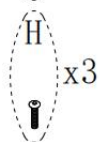
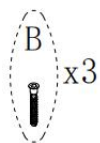
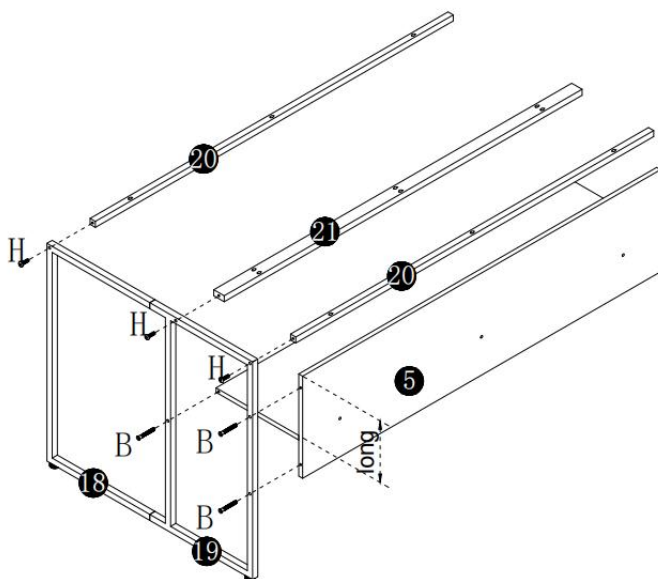

ASSEMBLY STEP

17

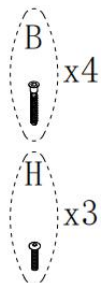
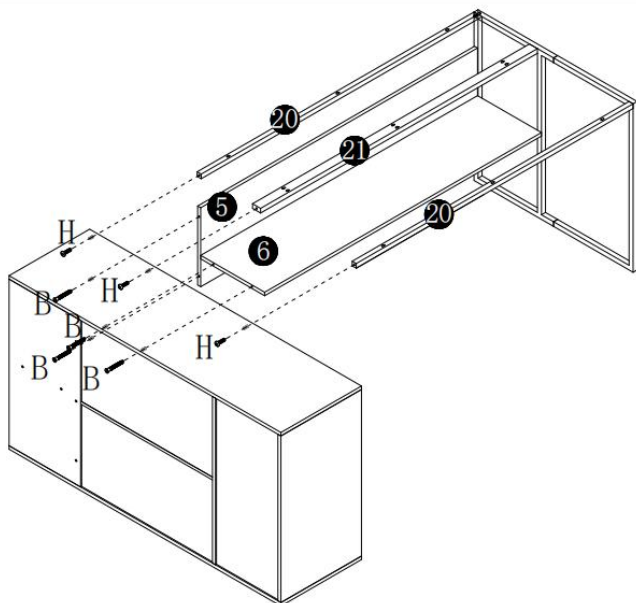

18

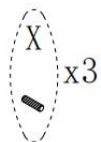
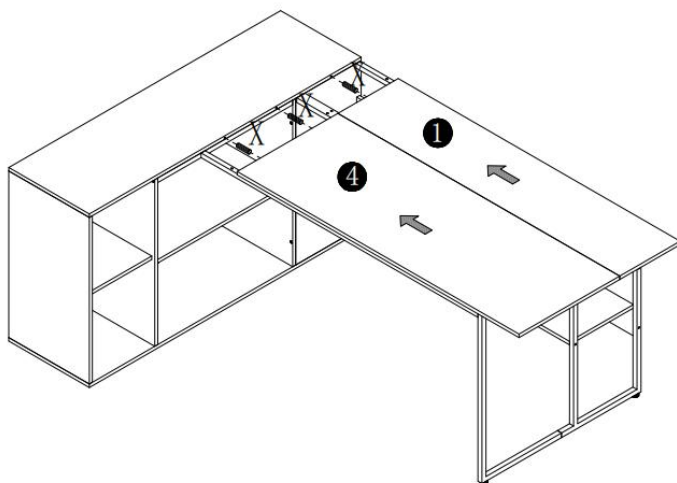

ASSEMBLY STEP

19

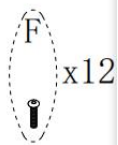
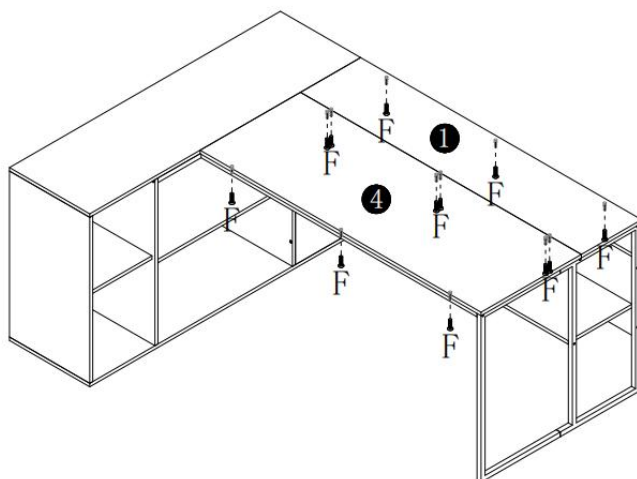

20

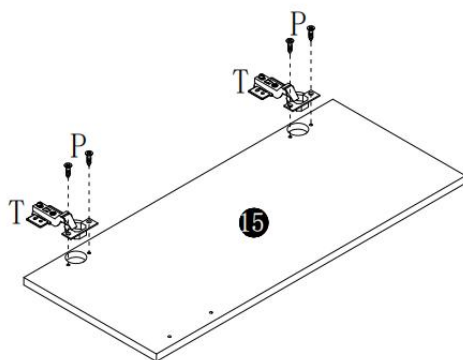

ASSEMBLY STEP

21

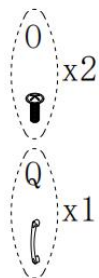
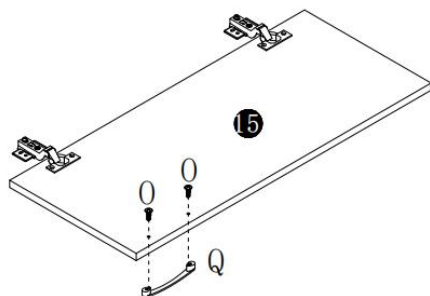

22

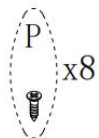
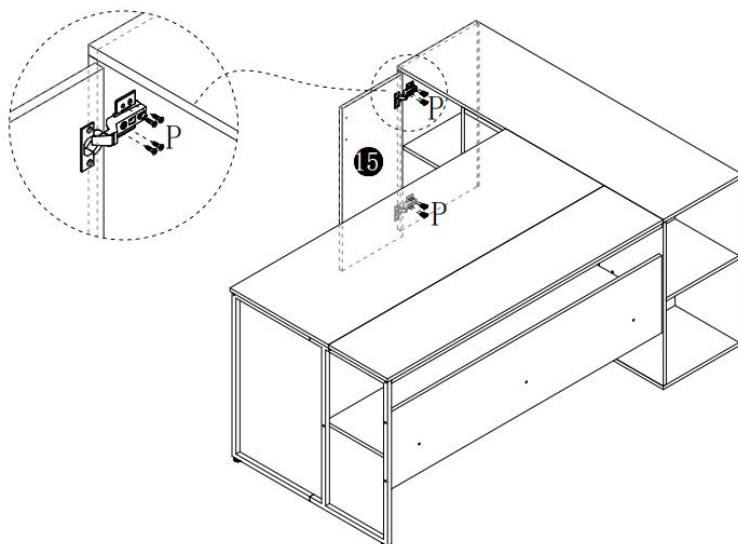

ASSEMBLY STEP

23

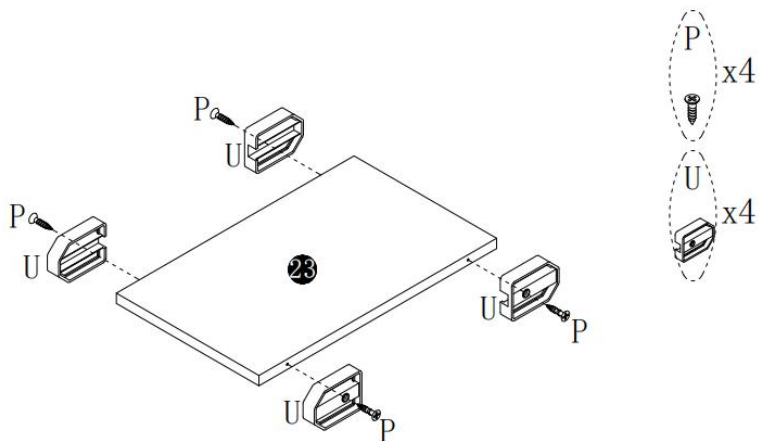

24

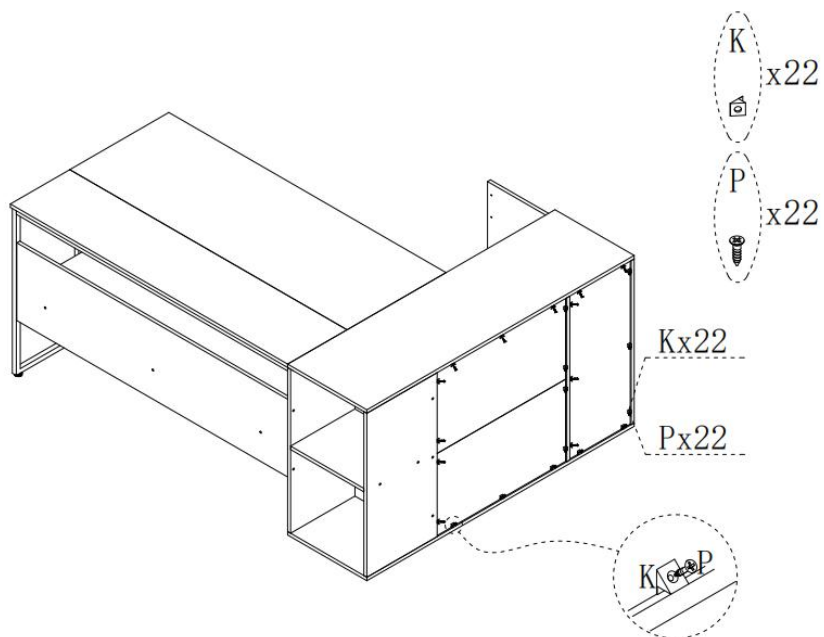

ASSEMBLY STEP

25

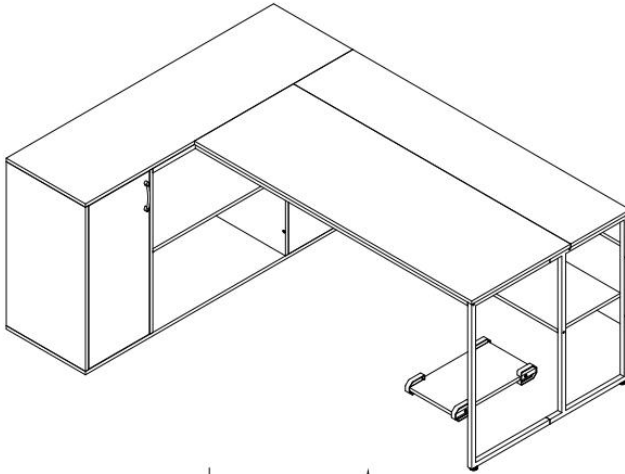

↓
OR
↑

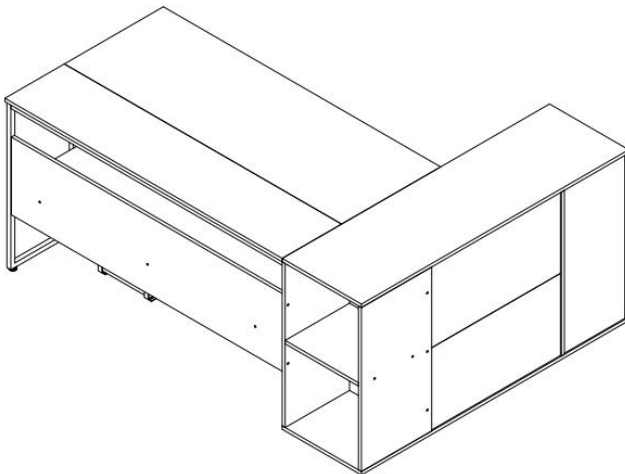

PRODUCT PARAMETER

Modell	C25024 3 D-01
Sicheres Ladegewicht	350 Pfund
Produktgröße (T*B*H)	1 8 00* 80 0* 75 0mm

* Produktspezifikationen, Aussehen und Design können ohne vorherige Ankündigung geändert werden.

Hersteller: Shanghai muxinmuyeyouxiangongsi

Adresse: Shuangchenglu 803nong11hao1602A-1609shi, baoshanqu, Shanghai 200000 CN.

Importiert nach AUS: SIHAO PTY LTD. 1 ROKEVA STREETEASTWOOD NSW 2122 Australien

Importiert in die USA: Sanven Technology Ltd. Suite 250, 9166 Anaheim Place, Rancho Cucamonga, CA 91730

EC	REP
-----------	------------

E-CrossStu GmbH
Mainzer Landstr.69, 60329 Frankfurt am Main.

UK	REP
-----------	------------

YH CONSULTING LIMITED.
C/O YH Consulting Limited Office 147, Centurion House, London Road, Staines-upon-Thames, Surrey, TW18 4AX



VEVOR

Affordable. Reliable. Home Improvement.

SCRIVANIA DIREZIONALE

MODELLO: C250243D-01

VEVOR

Affordable. Reliable. Home Improvement.

EXECUTIVE DESK

MODELLO: C25024 3 D-01

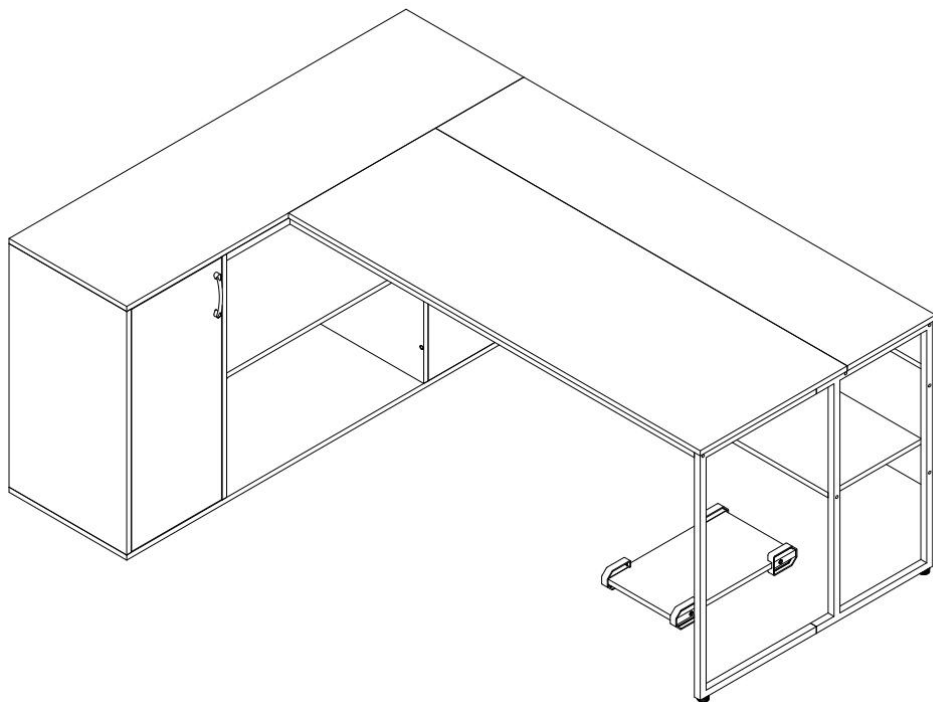

Queste sono le istruzioni originali, si prega di leggere attentamente tutte le istruzioni del manuale prima dell'uso. VEVOR si riserva la piena interpretazione del proprio manuale utente. L'aspetto del prodotto dipenderà dal prodotto ricevuto. Vi preghiamo di scusarci se non vi informeremo più in caso di aggiornamenti tecnologici o software sul nostro prodotto.

SAFETY INSTRUCTIONS

INTRODUZIONE

Grazie per aver acquistato i nostri prodotti. Il nostro obiettivo principale è sempre stato quello di fornire ai clienti prodotti e servizi della migliore qualità. Prima di utilizzare il prodotto, leggere attentamente questo documento.

manuale di istruzioni attentamente per garantirne il corretto utilizzo. Conservare il manuale di istruzioni in un luogo dove l'utente può trovarlo in qualsiasi momento.

ASSEMBLEA PRECAUZIONI

Ce ne sono molti componenti e accessori nella confezione. Ogni il componente e l'accessorio sono etichettati con una lettera o un numero, controllare attentamente prima di utilizzarli. Tenerli lontano dalla portata dei bambini prevenire gli incidenti.

34. Montare solo secondo queste istruzioni. Un montaggio improprio può comportare pericoli.
35. Durante il montaggio, indossare occhiali di sicurezza omologati ANSI e guanti da lavoro resistenti.
36. Mantenere l'area di assemblaggio pulita e ben illuminata.
37. Durante l'assemblea, tenere gli astanti lontani dall'area.
38. Non montare se si è stanchi o sotto l'effetto di alcol, droghe o medicinali.
39. Le capacità del prodotto si applicano solo ai prodotti correttamente e completamente assemblati.
40. Si prega di installare il prodotto su un sottofondo pulito e morbido (ad esempio un tappeto) o cartone) per evitare di graffiare o danneggiare la superficie del prodotto .
41. Se possibile, è possibile utilizzare utensili elettrici per facilitare il montaggio.
42. I componenti principali del prodotto sono relativamente pesanti. Si prega di pagare attenzione alla sicurezza durante l'installazione .

43. Il prodotto non è stabile durante l'installazione. Non spostarlo in modo casuale, prima che sia completamente installato .
44. Per ulteriori informazioni riguardanti le parti elencate di seguito pagine, fare riferimento allo schema di montaggio di questo manuale. Disimballare e separare tutte le parti in un'area di lavoro pulita.

***ASSICURATI DI SEGUIRE I PASSAGGI DI INSTALLAZIONE NEL MANUALE PER EVITARE PERDITE INUTILI CAUSATE DA UN'INSTALLAZIONE NON CORRETTA.**

UTILIZZO PRECAUZIONI







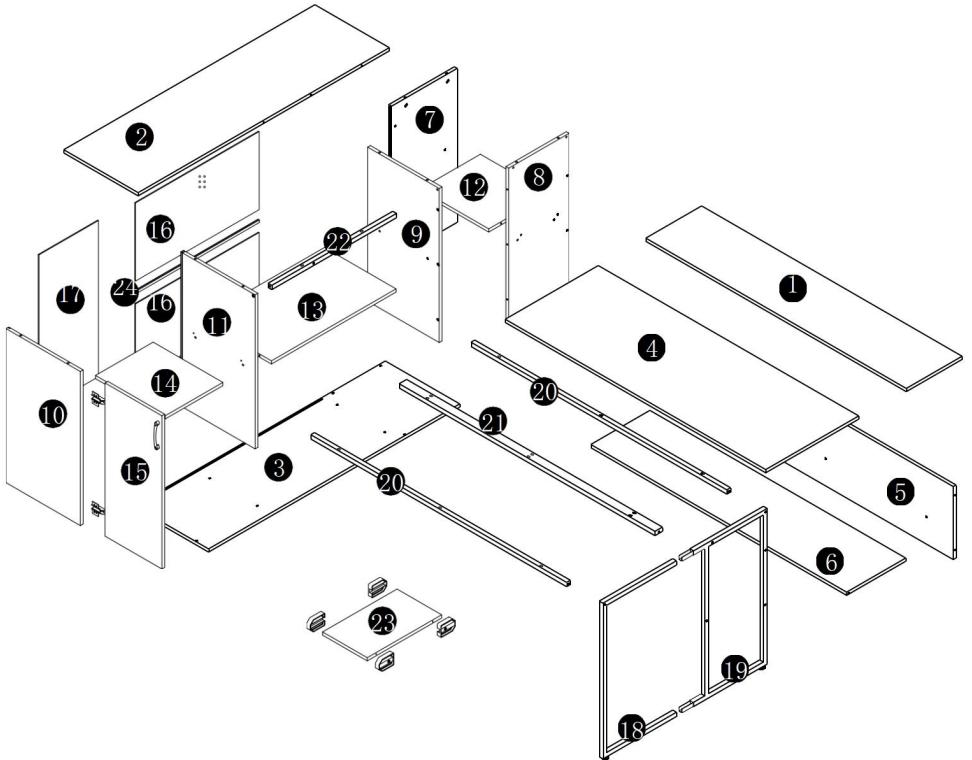







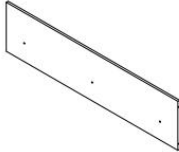

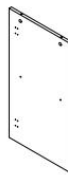

- 13) Non superare i valori specificati capacità di peso.
- 14) Utilizzare solo su una superficie piana, orizzontale, dura e liscia, in grado di sostenere in sicurezza una scrivania Executive completamente carica.
- 15) Utilizzare solo come previsto.
- 16) Ispezionare prima di ogni utilizzo; non utilizzare se alcune parti sono allentate o danneggiate.

CONSERVARE QUESTO MANUALE



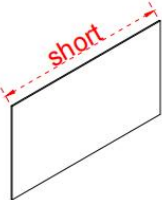
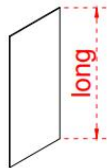

EXPLODED VIEW



















PARTS LIST

 <p>1 1pc</p>	 <p>2 1pc</p>	 <p>3 1pc</p>	 <p>4 1pc</p>
 <p>5 1pc</p>	 <p>6 1pc</p>	 <p>7 1pc</p>	 <p>8 1pc</p>
 <p>9 1pc</p>	 <p>10 1pc</p>	 <p>11 1pc</p>	 <p>12 1pc</p>
 <p>13 1pc</p>	 <p>14 1pc</p>	 <p>15 1pc</p>	 <p>16 2pcs</p>
 <p>17 1pc</p>	 <p>18 1pc</p>	 <p>19 1pc</p>	 <p>20 2pcs</p>

PARTS LIST

			
21 1pc	22 1pc	23 1pc	24 1pc

 M6X40MM A 14pcs	 M7X50MM B 34pcs	 C 14pcs	 M6X30MM F 14pcs	 M6X40MM H 8pcs
 K 22pcs	 M6X10MM N 4pcs	 M4X18MM O 2pcs	 ST3. 5X12MM P 38pcs	 Q 1pc
 DWX15MM T 2pcs	 U 4pcs	 X 3pcs	 M8X14MM Y 2pcs	 1pc
				

ASSEMBLY STEP

Installazione di camme e perni

Avvitare il perno nel foro. Per impostare correttamente le camme, assicurarsi che la freccia sulla camma si apra verso il foro del perno che si sta bloccando. Bloccare la camma ruotando la testa della camma con un cacciavite fino a quando non è serrata. Non utilizzare un cacciavite elettrico per assemblare. unità.

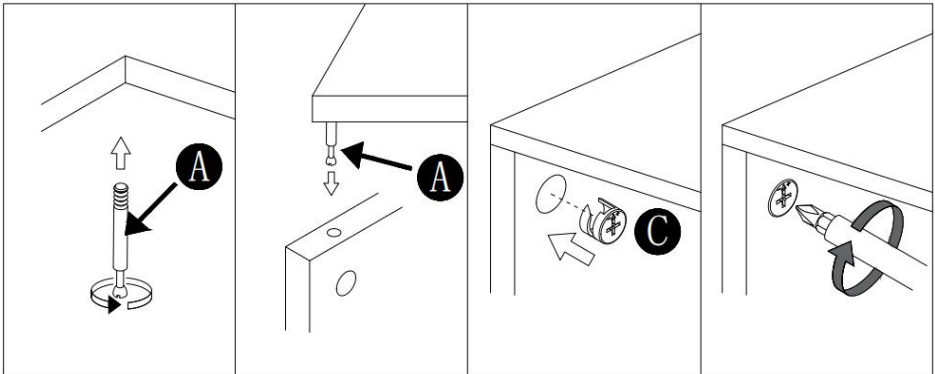

Leggere attentamente ogni passaggio prima di iniziare. È molto importante che ogni passaggio delle istruzioni venga eseguito nell'ordine corretto. Se questi passaggi non vengono seguiti in sequenza, si verificheranno difficoltà di montaggio. verificarsi.

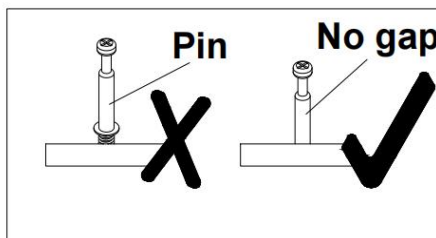

ASSEMBLY STEP

1

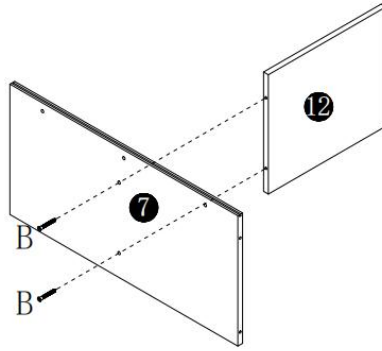
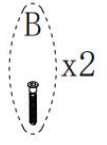

2

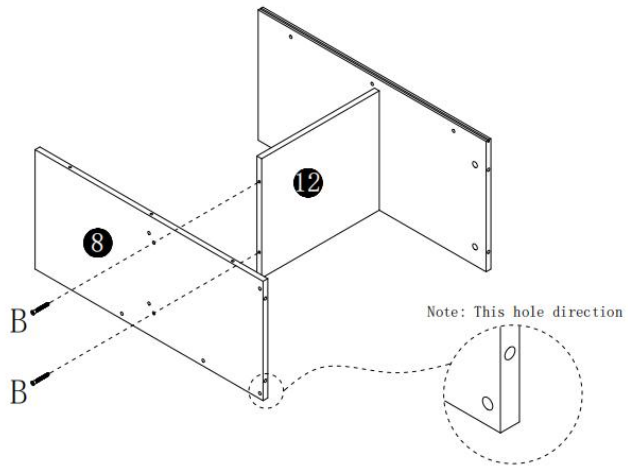
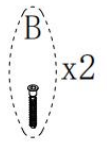

ASSEMBLY STEP

3

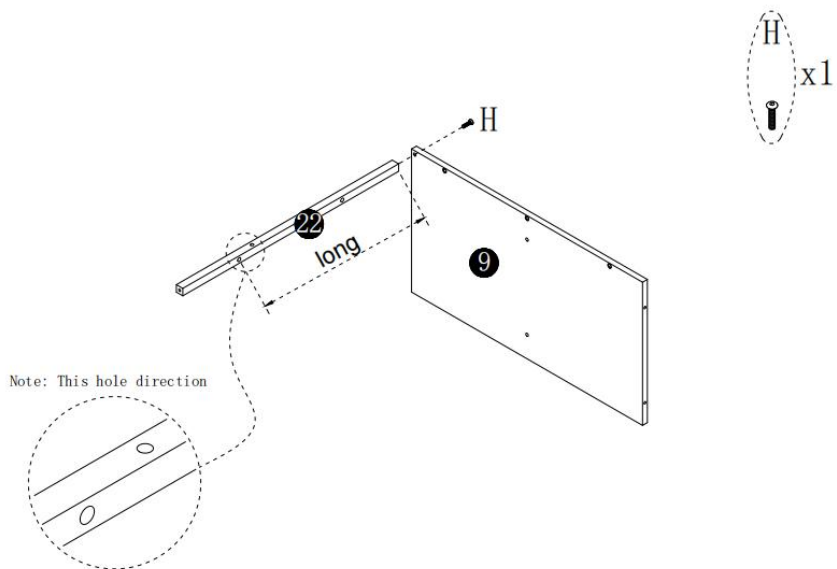

4

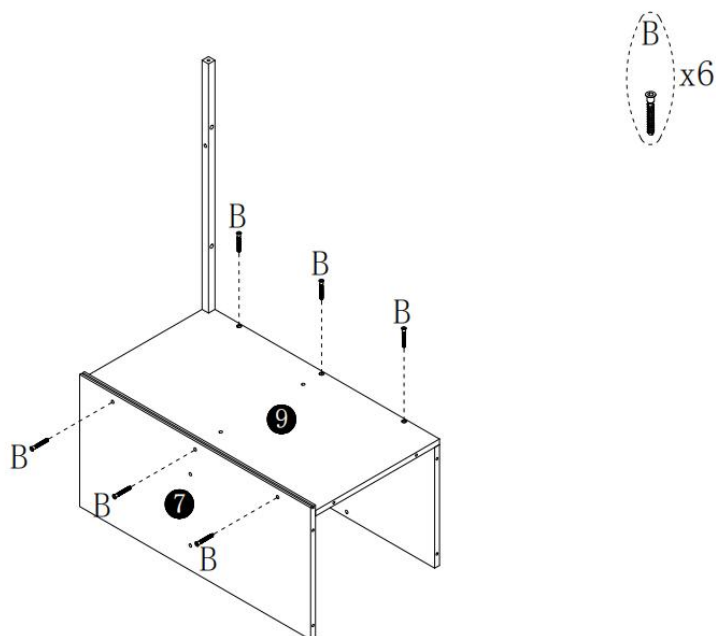

ASSEMBLY STEP

5

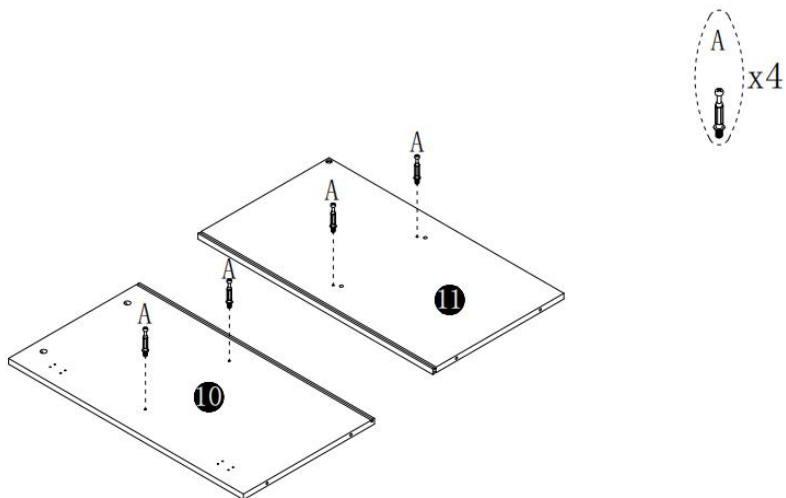

6

Note: This hole direction

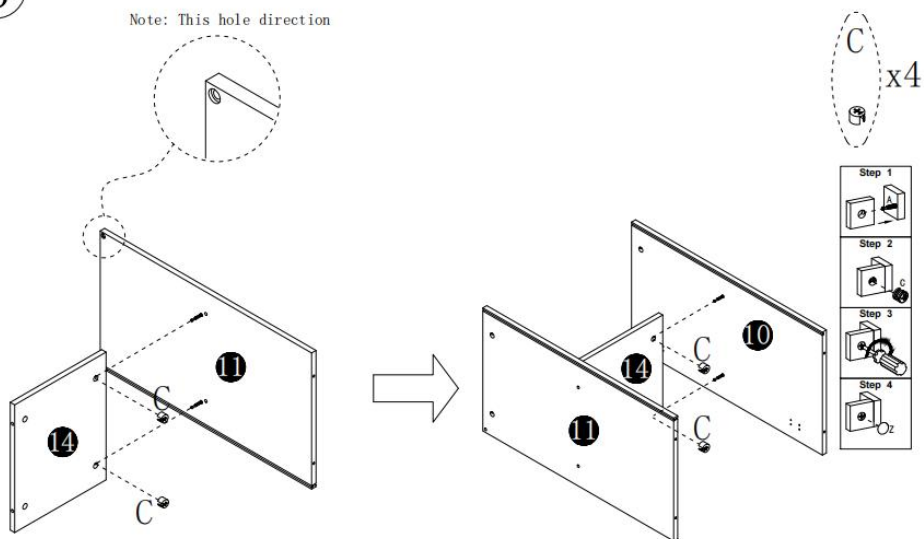

ASSEMBLY STEP

7

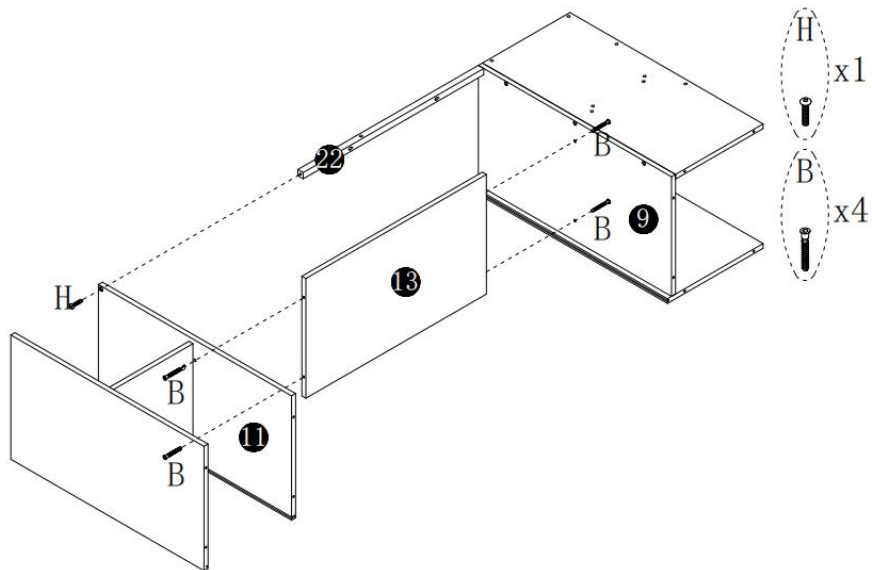

8

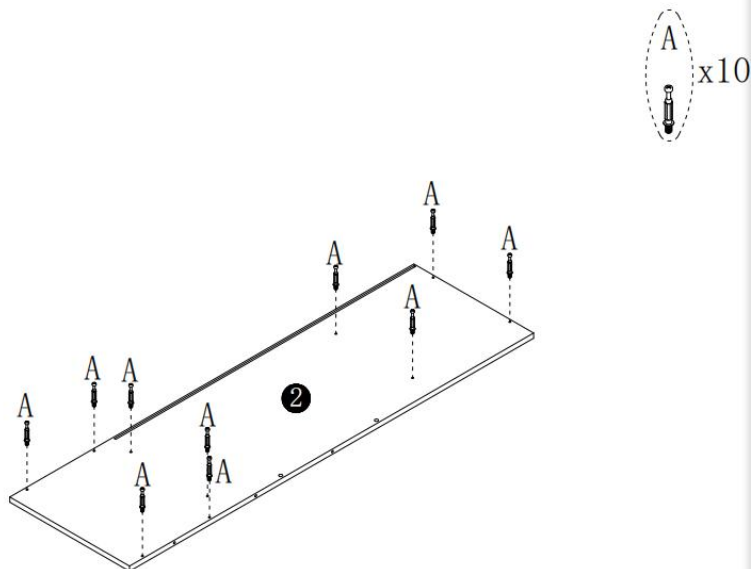

ASSEMBLY STEP

9

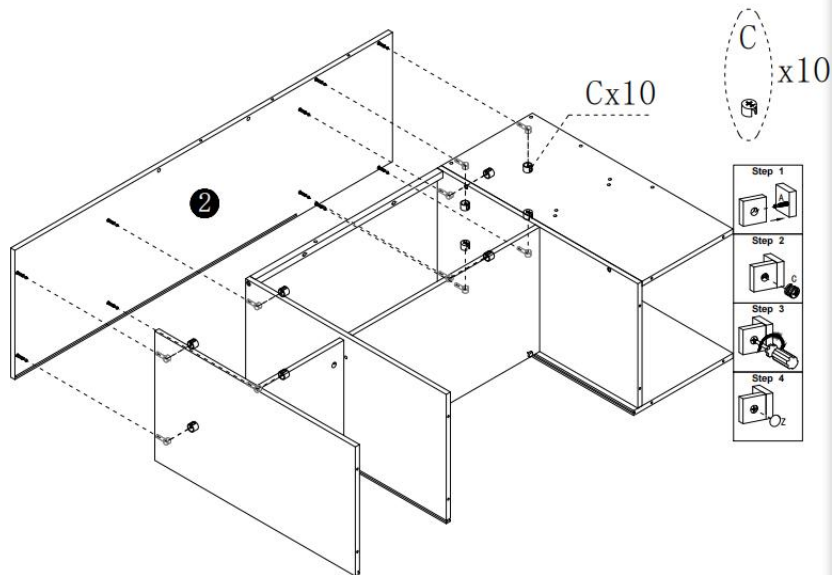

10

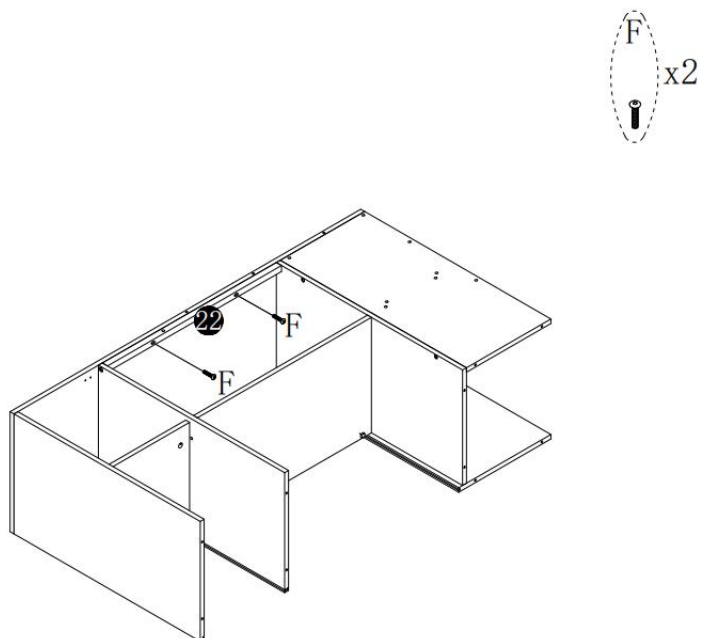

ASSEMBLY STEP

11

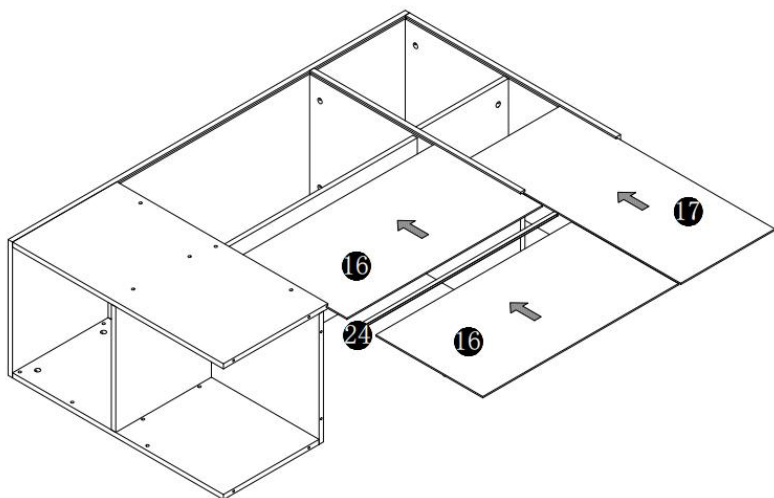

12

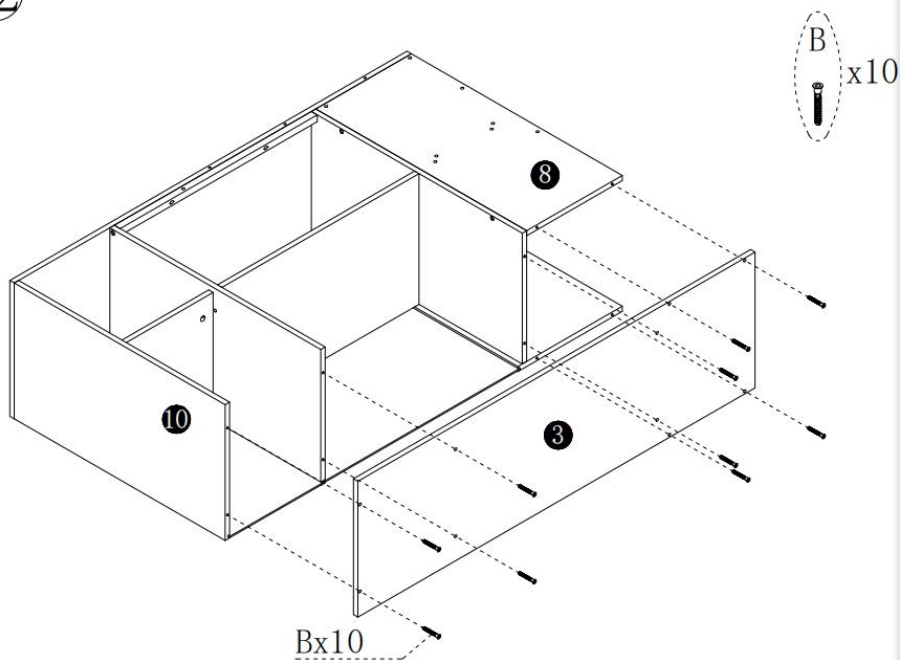

ASSEMBLY STEP

13

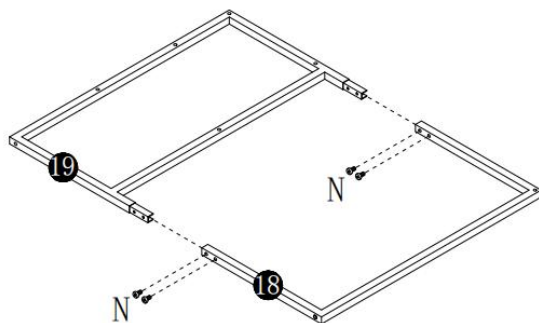
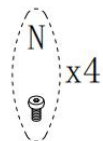

14

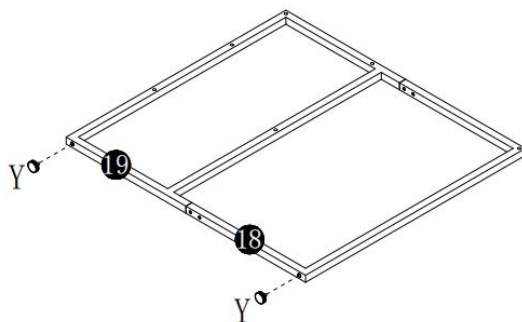
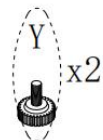

ASSEMBLY STEP

15

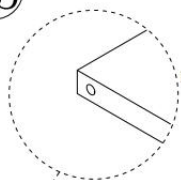

Note: This hole direction

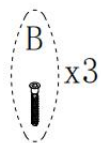
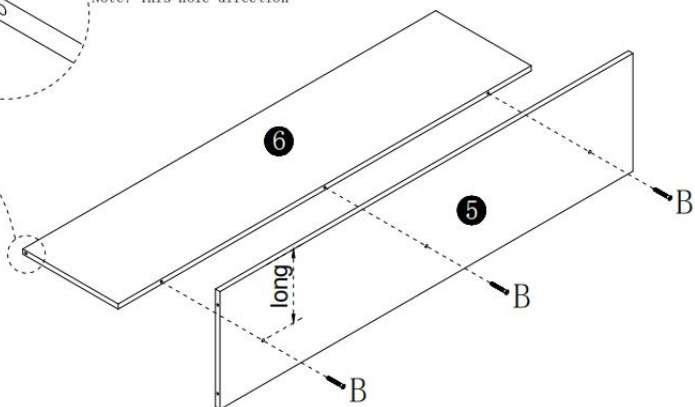

16

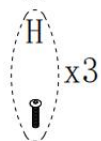
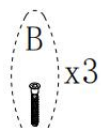
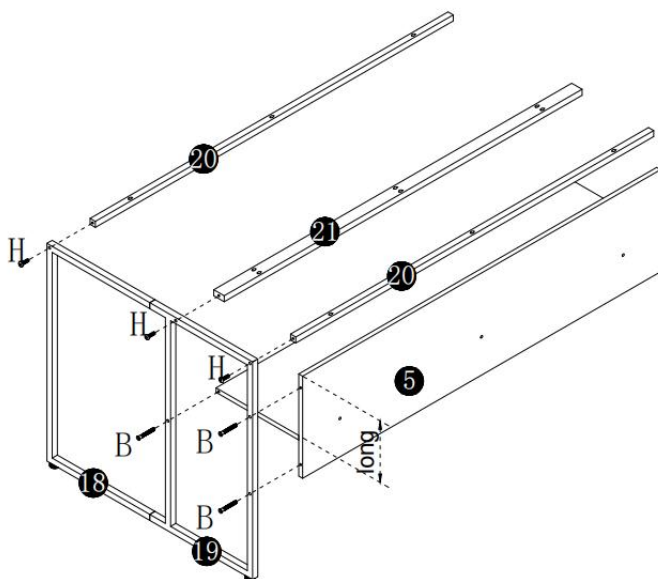

ASSEMBLY STEP

17

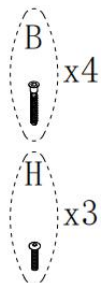
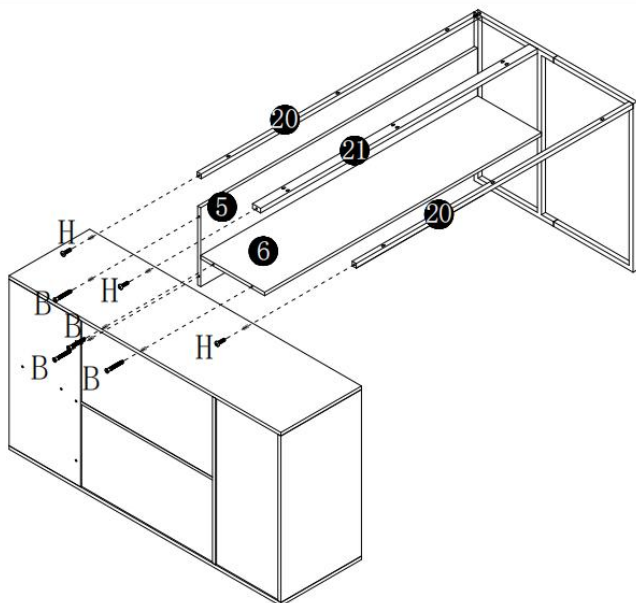

18

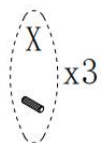
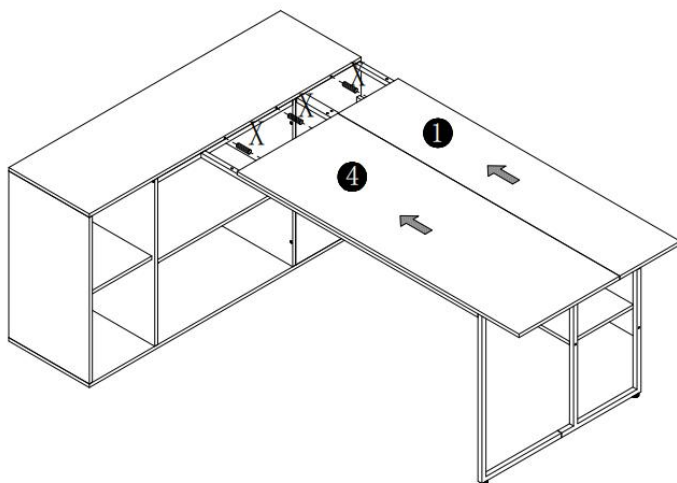

ASSEMBLY STEP

19

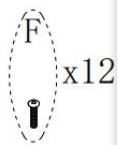
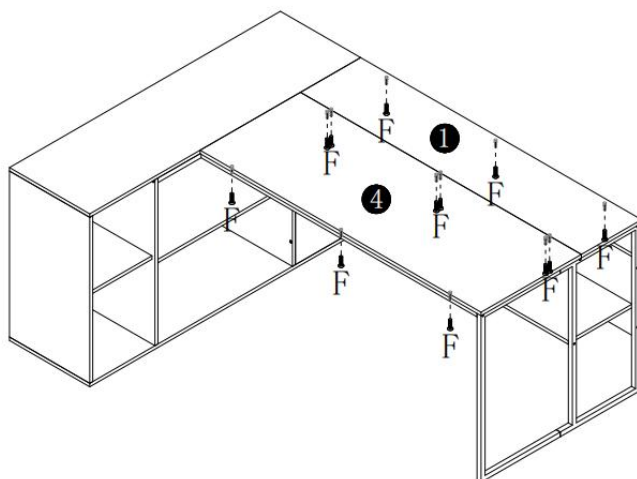

20

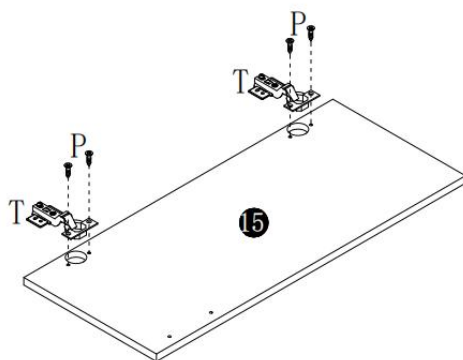

ASSEMBLY STEP

21

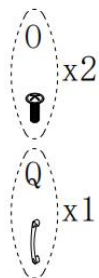
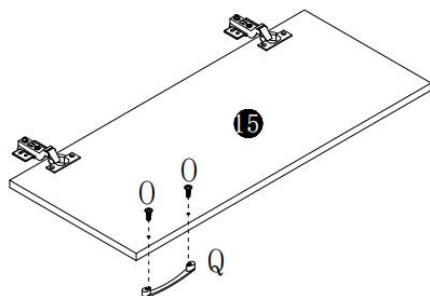

22

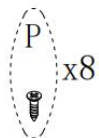
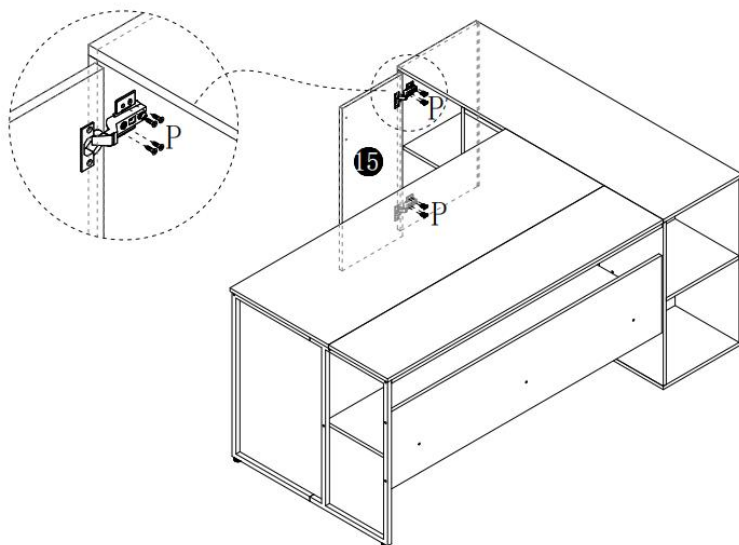

ASSEMBLY STEP

23

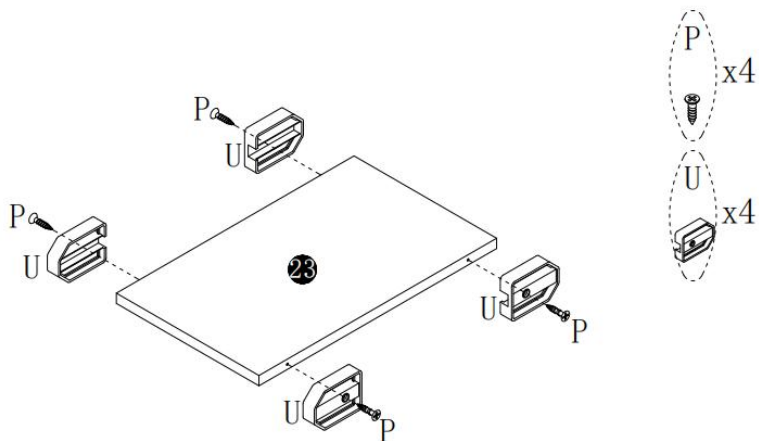

24

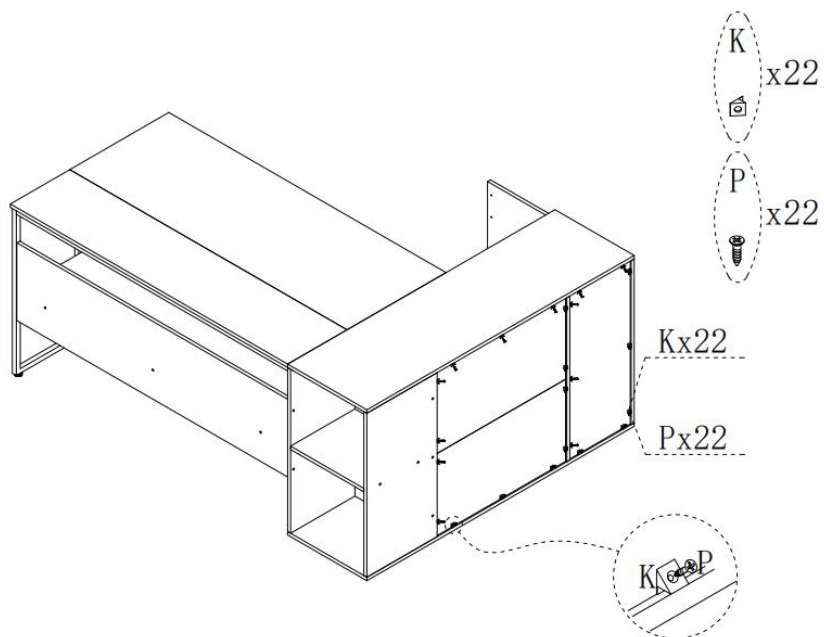

ASSEMBLY STEP

25

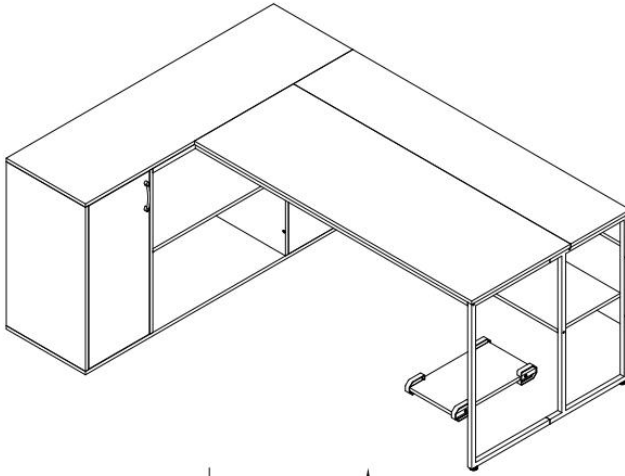

↓
OR
↑

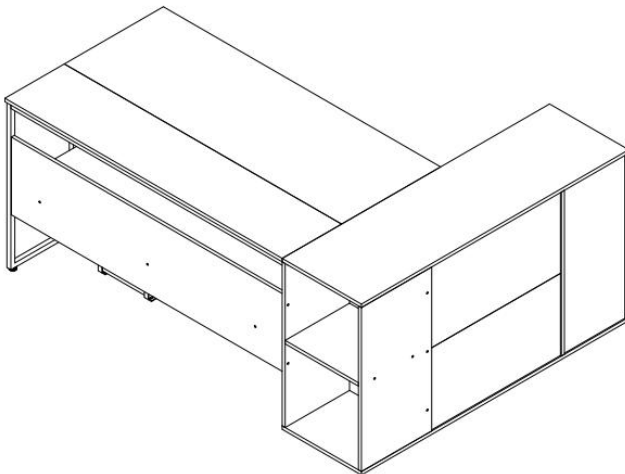

PRODUCT PARAMETER

Modello	C25024 3 D-01
Peso di carico sicuro	350 libbre
Dimensioni del prodotto (P*L*A)	1 8 00* 80 0* 75 0mm

* Le specifiche, l'aspetto e il design dei prodotti sono soggetti a modifiche senza preavviso.

Produttore: Shanghaimuxinmuyeyouxiangongsi

Indirizzo: Shuangchenglu 803nong11hao1602A-1609shi, baoshanqu, shanghai 200000 CN.

Importato in AUS: SIHAO PTY LTD. 1 ROKEVA STREETEASTWOOD NSW 2122 Australia

Importato negli USA: Sanven Technology Ltd. Suite 250, 9166 Anaheim Place, Rancho Cucamonga, CA 91730

EC	REP
-----------	------------

E-CrossStu GmbH
Mainzer Landstr.69, 60329 Frankfurt am Main.

UK	REP
-----------	------------

YH CONSULTING LIMITED.
C/O YH Consulting Limited Office 147, Centurion House, London Road, Staines-upon-Thames, Surrey, TW18 4AX



VEVOR

Affordable. Reliable. Home Improvement.

ESCRITORIO EJECUTIVO

MODELO: C250243D-01

VEVOR

Affordable. Reliable. Home Improvement.

EXECUTIVE DESK

MODELO: C25024 3 D-01

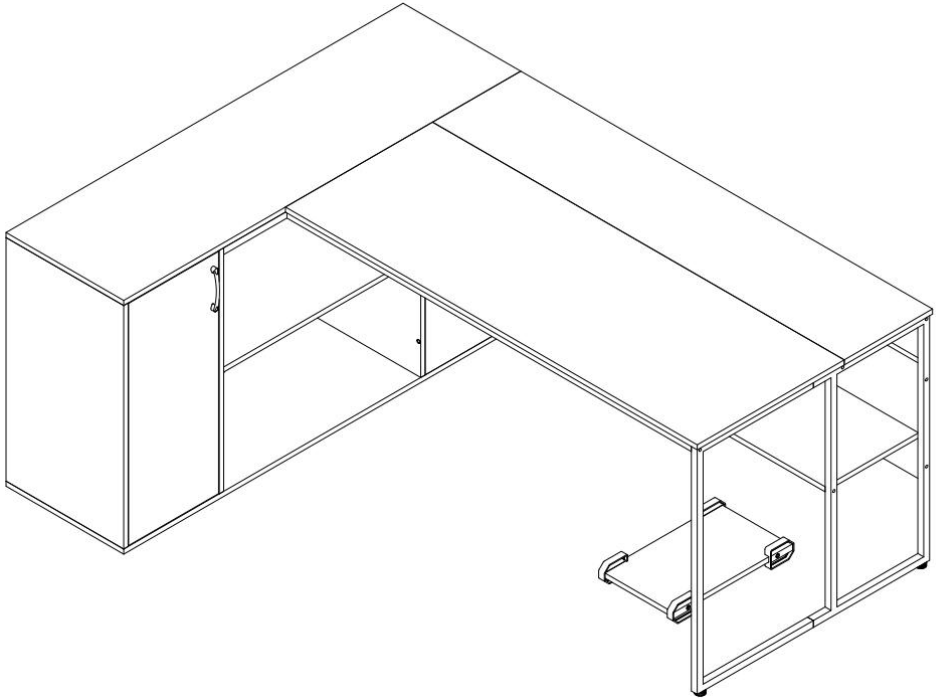

Estas son las instrucciones originales; lea atentamente todas las instrucciones del manual antes de utilizarlo. VEVOR se reserva el derecho de interpretar este manual de usuario. La apariencia del producto dependerá del producto que haya recibido. Le rogamos que nos disculpe si no le informamos de nuevo si hay actualizaciones tecnológicas o de software en nuestro producto.

SAFETY INSTRUCTIONS

INTRODUCCIÓN

Gracias por adquirir nuestros productos. Nuestro compromiso con la mejor calidad y el mejor servicio siempre ha sido nuestro objetivo. Antes de usar el producto, lea esto. manual de instrucciones con cuidado para garantizar un uso correcto. Conserve el manual de instrucciones en un lugar donde el usuario puede encontrarlo en cualquier momento.

ASAMBLEA PRECAUCIONES

Hay muchos Componentes y accesorios incluidos en el paquete. Cada uno El componente y el accesorio están etiquetados con una letra o un número, verifique cuidadosamente antes de utilizar cualquiera de ellos. Manténgalos fuera del alcance de los niños. Prevenir accidentes.

45. Ensamble únicamente según estas instrucciones. Un montaje incorrecto puede causar peligros.
46. Use gafas de seguridad aprobadas por ANSI y guantes de trabajo resistentes durante el montaje.
47. Mantenga el área de reunión limpia y bien iluminada.
48. Mantenga a los transeúntes fuera del área durante el montaje.
49. No se reúna si está cansado o bajo la influencia del alcohol, drogas o medicamentos.
50. Las capacidades del producto se aplican únicamente a productos ensamblados de forma correcta y completa.
51. Instale el producto sobre una base limpia y suave (como una alfombra). o cartón) para evitar rayar o dañar la superficie del producto .
52. Si es posible, puedes utilizar herramientas eléctricas para facilitar el montaje.
53. Los componentes principales del producto son relativamente pesados. Por favor, preste atención. Atención a la seguridad durante la

instalación .

54. El producto no es estable durante la instalación. No lo mueva de forma aleatoria. antes de que esté completamente instalado .
55. Para obtener información adicional sobre las piezas enumeradas a continuación
páginas, consulte el diagrama de montaje de este manual.
Desenvuelva y separe todas las piezas en un área de trabajo limpia.

***ASEGÚRESE DE SEGUIR LOS PASOS DE INSTALACIÓN DEL MANUAL PARA EVITE PÉRDIDAS INNECESARIAS CAUSADAS POR UNA INSTALACIÓN INCORRECTA.**

USAR PRECAUCIONES







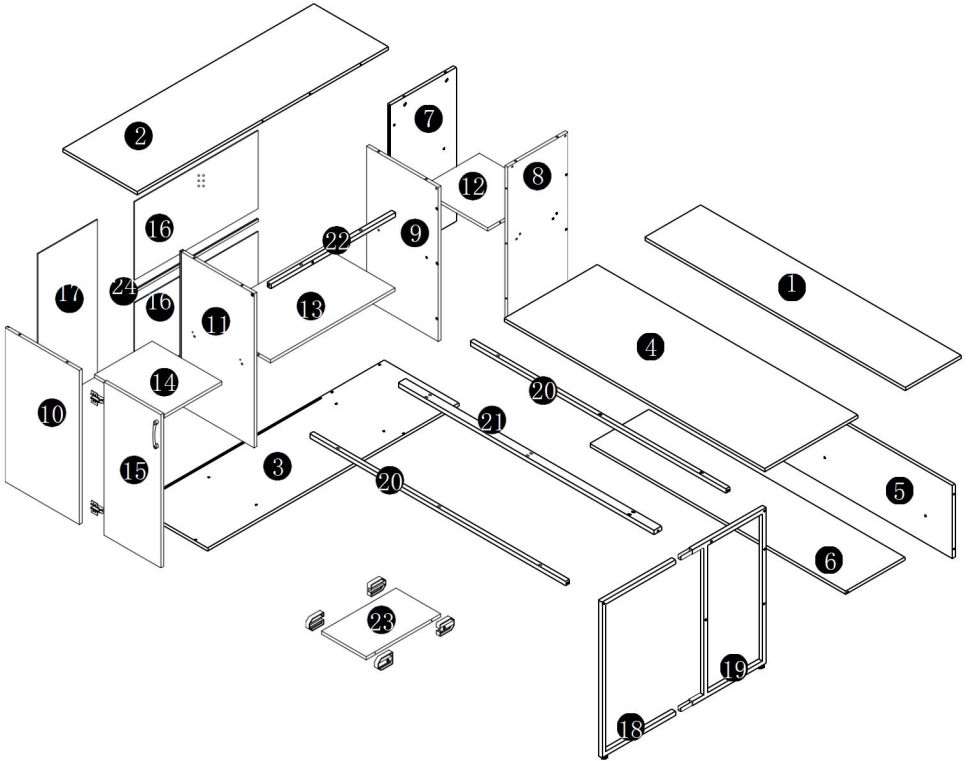







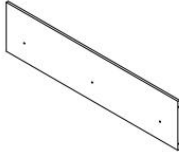

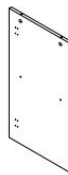

- 17) No exceda lo especificado capacidades de peso.
- 18) Úselo únicamente sobre una superficie plana, nivelada, dura y lisa que pueda soportar de forma segura un escritorio ejecutivo completamente cargado.
- 19) Úselo únicamente según lo previsto.
- 20) Inspeccione antes de cada uso; no lo utilice si las piezas están sueltas o dañadas.

GUARDE ESTE MANUAL



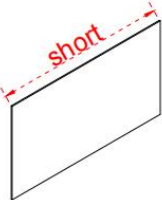
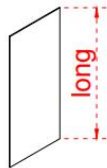

EXPLODED VIEW



















PARTS LIST

 <p>1 1pc</p>	 <p>2 1pc</p>	 <p>3 1pc</p>	 <p>4 1pc</p>
 <p>5 1pc</p>	 <p>6 1pc</p>	 <p>7 1pc</p>	 <p>8 1pc</p>
 <p>9 1pc</p>	 <p>10 1pc</p>	 <p>11 1pc</p>	 <p>12 1pc</p>
 <p>13 1pc</p>	 <p>14 1pc</p>	 <p>15 1pc</p>	 <p>16 2pcs</p>
 <p>17 1pc</p>	 <p>18 1pc</p>	 <p>19 1pc</p>	 <p>20 2pcs</p>

PARTS LIST

			
21 1pc	22 1pc	23 1pc	24 1pc

 M6X40MM A 14pcs	 M7X50MM B 34pcs	 C 14pcs	 M6X30MM F 14pcs	 M6X40MM H 8pcs
 K 22pcs	 M6X10MM N 4pcs	 M4X18MM O 2pcs	 ST3. 5X12MM P 38pcs	 Q 1pc
 DWX15MM T 2pcs	 U 4pcs	 X 3pcs	 M8X14MM Y 2pcs	 1pc
				

ASSEMBLY STEP

Instalación de levas y pasadores

Enrosque el pasador en el orificio. Para ajustar las levas correctamente, asegúrese de que la flecha de la leva esté orientada hacia el orificio del pasador que bloquea. Bloquee la leva girando la cabeza de la leva con un destornillador hasta que esté apretada. No utilice un destornillador eléctrico para ensamblar. unidad.

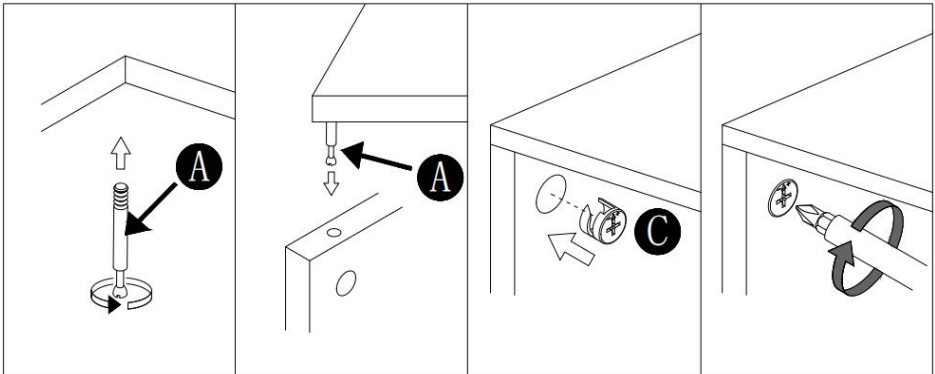

Lea cada paso detenidamente antes de comenzar. Es muy importante que cada paso de las instrucciones se realice en el orden correcto. Si no se siguen estos pasos en secuencia, surgirán dificultades de montaje. ocurrir.

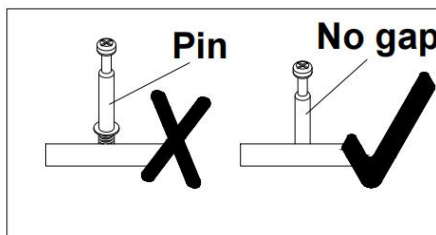

ASSEMBLY STEP

1

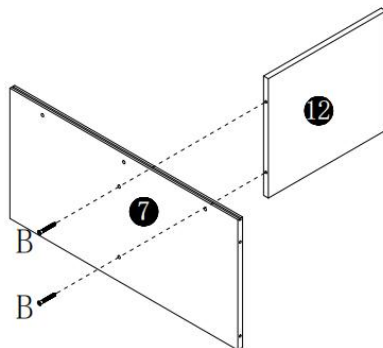
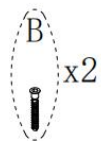

2

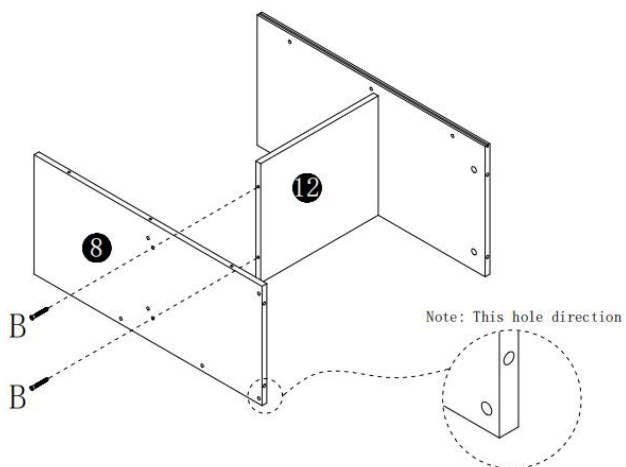
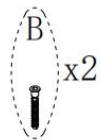

ASSEMBLY STEP

3

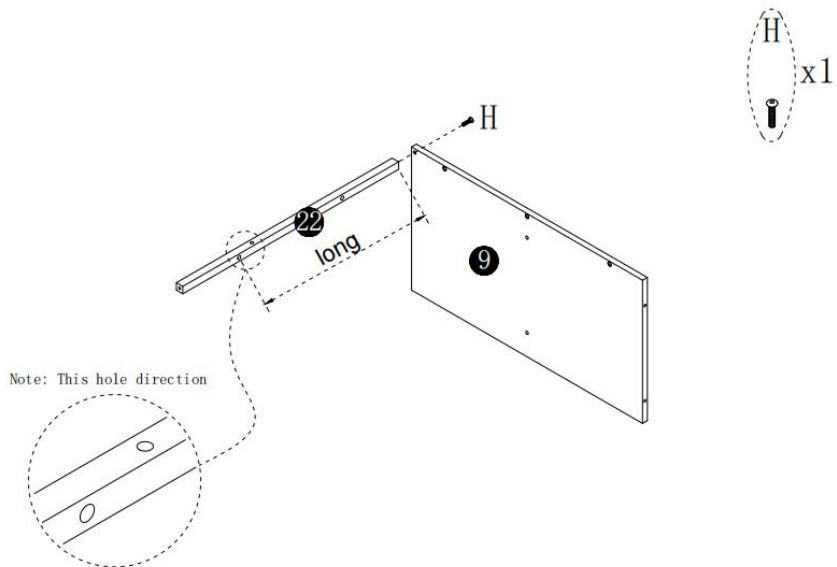

4

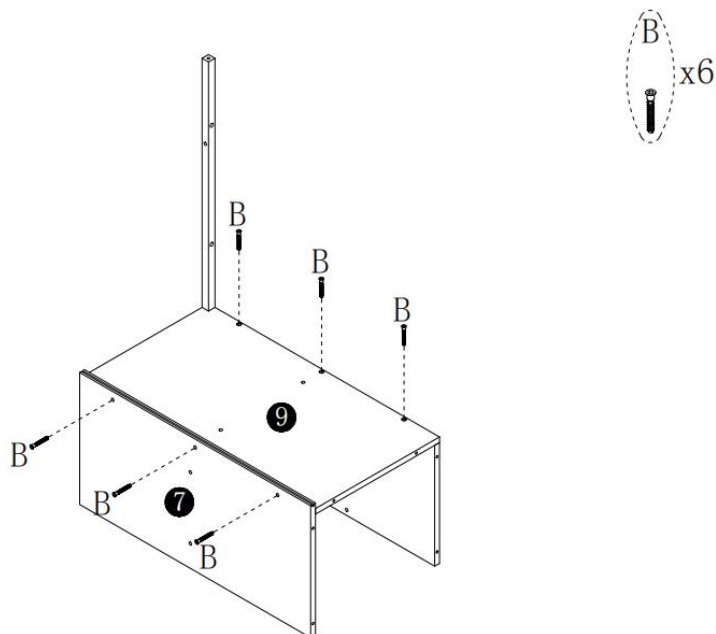

ASSEMBLY STEP

5

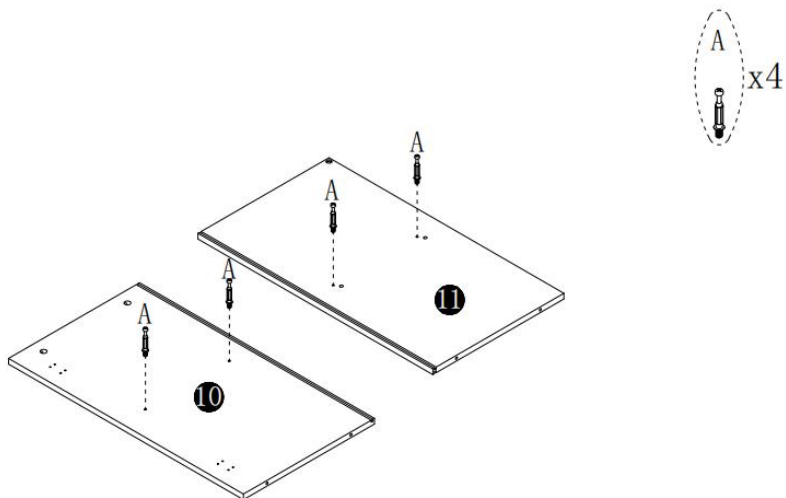

6

Note: This hole direction

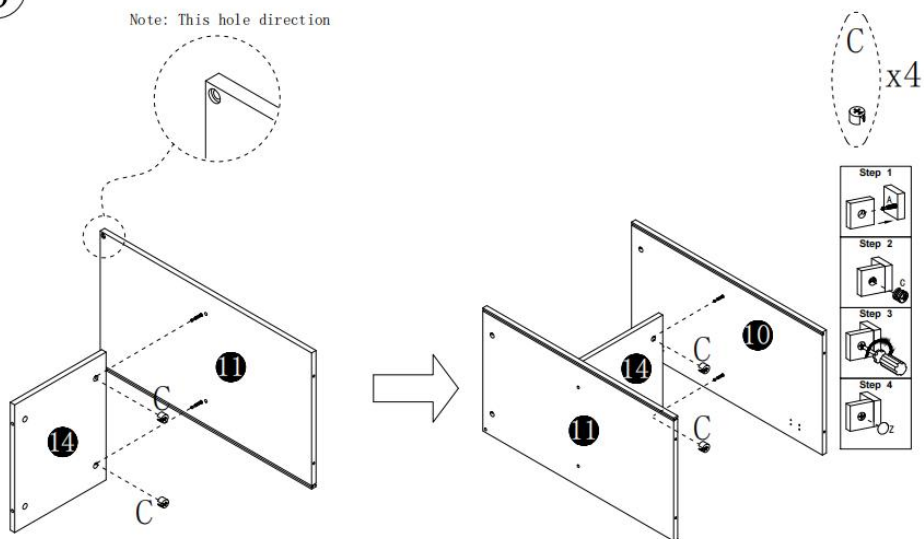

ASSEMBLY STEP

7

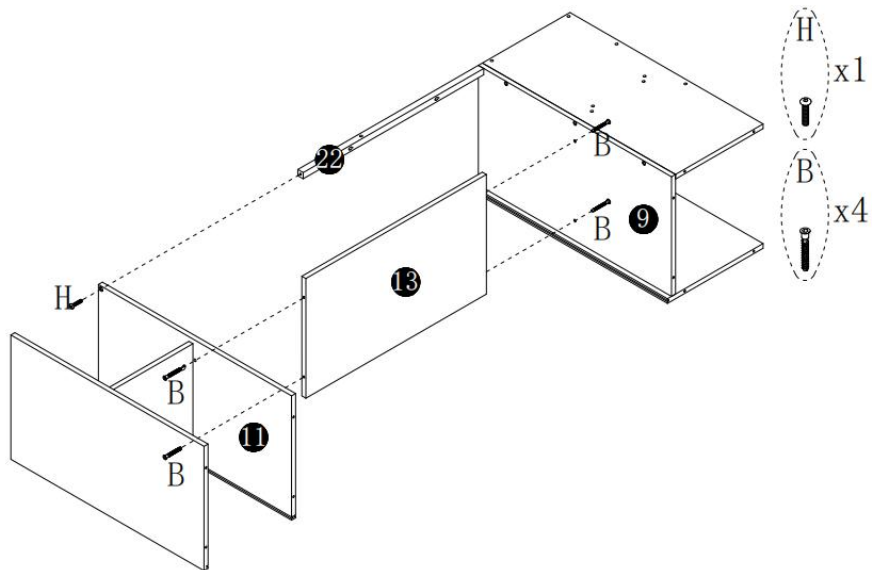

8

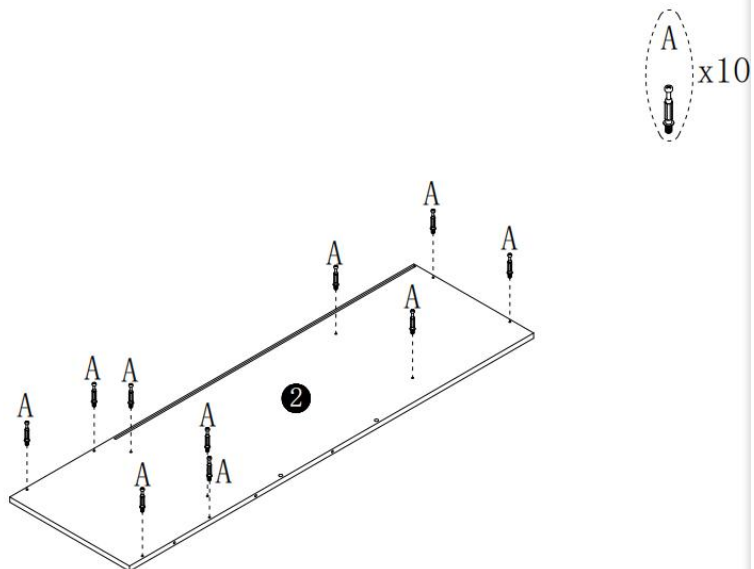

ASSEMBLY STEP

9

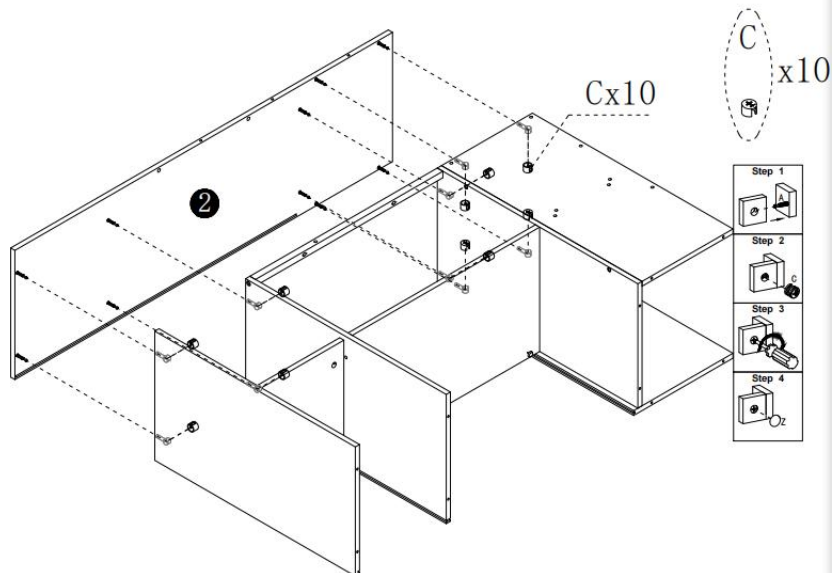

10

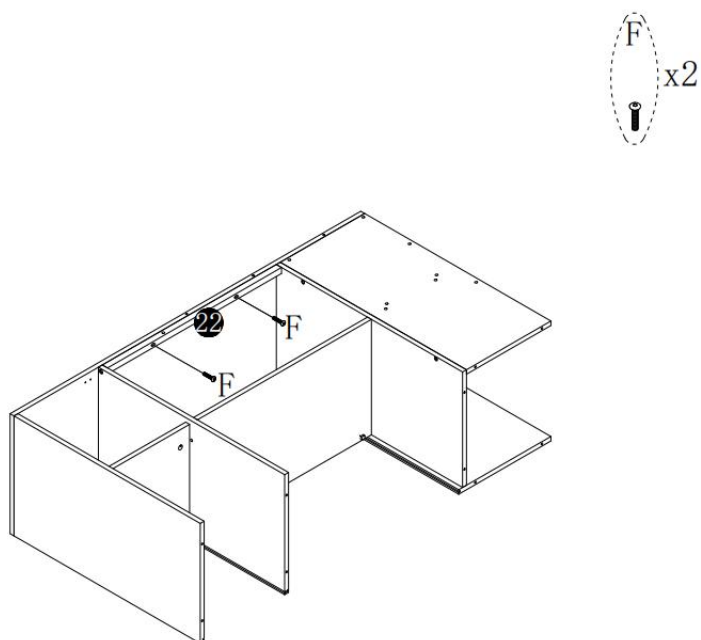

ASSEMBLY STEP

11

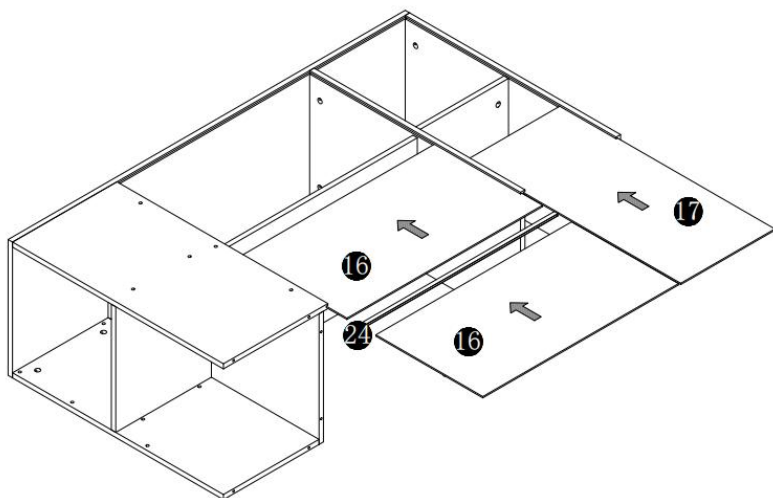

12

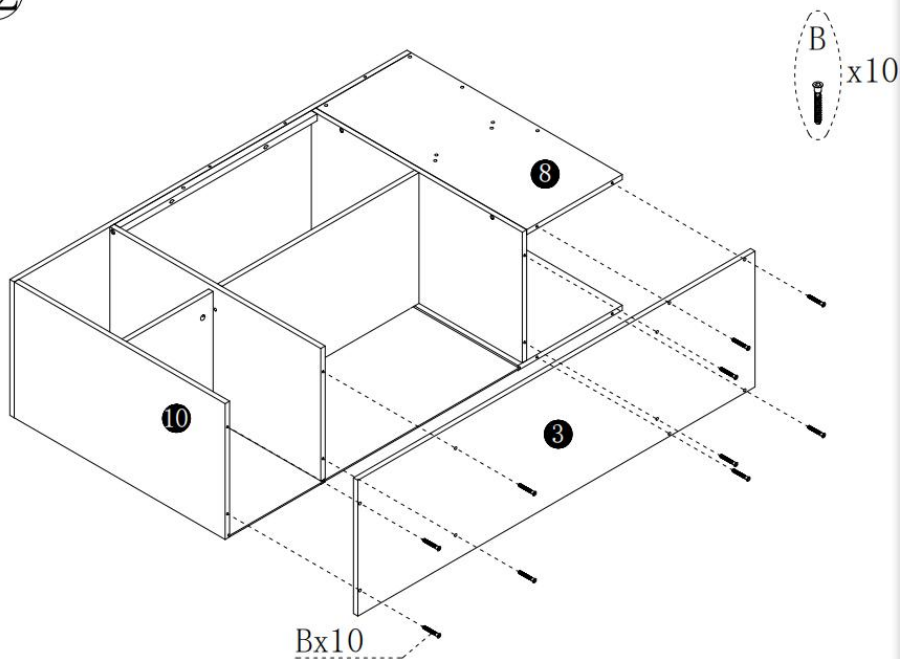

ASSEMBLY STEP

13

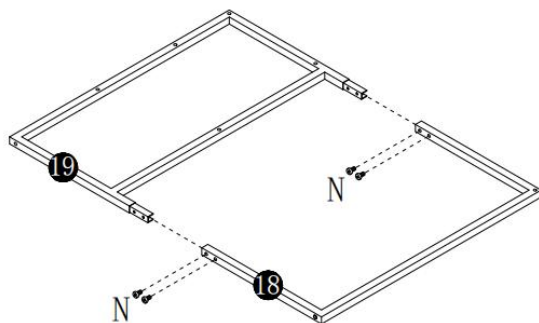
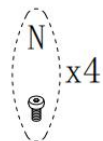

14

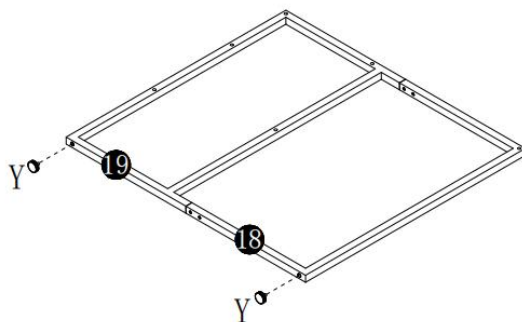
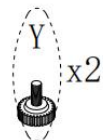

ASSEMBLY STEP

15

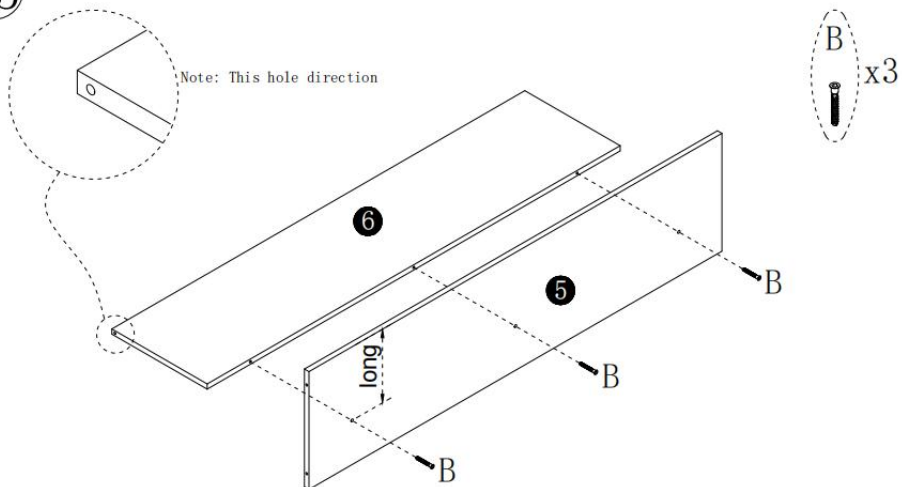

16

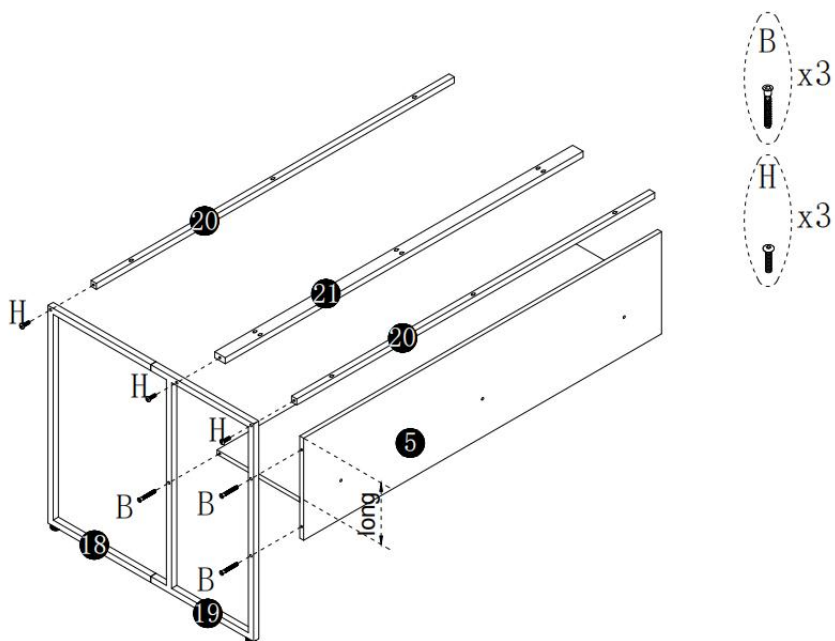

ASSEMBLY STEP

17

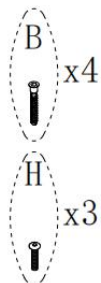
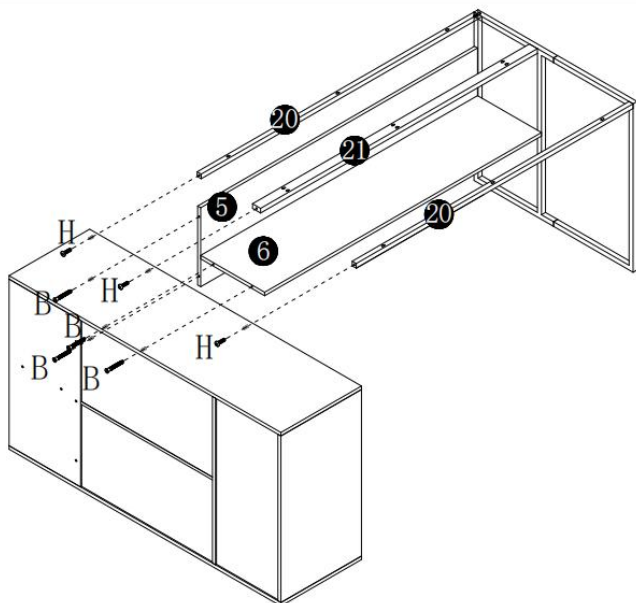

18

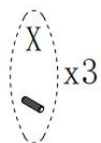
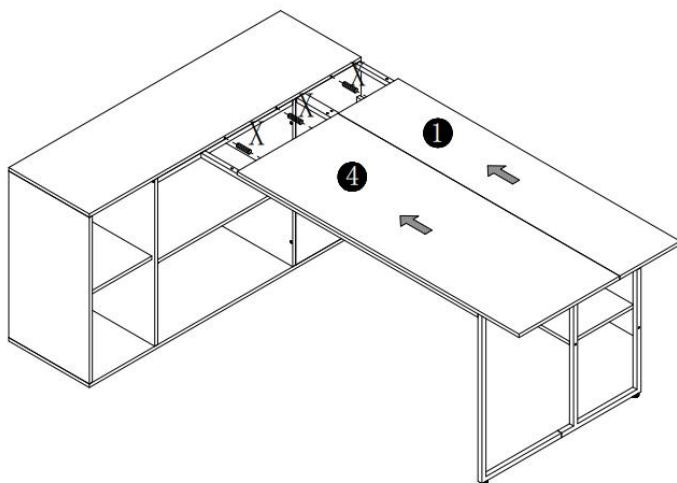

ASSEMBLY STEP

19

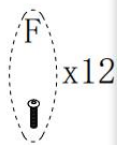
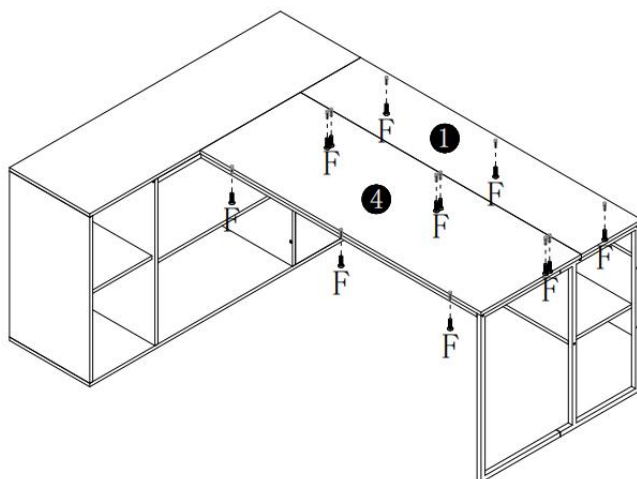

20

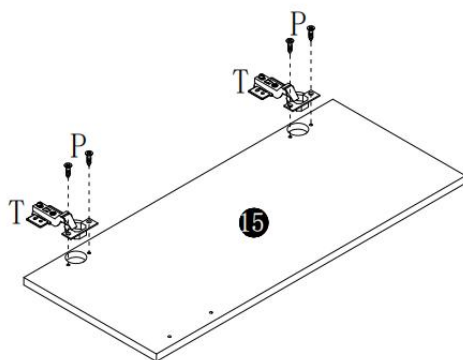

ASSEMBLY STEP

21

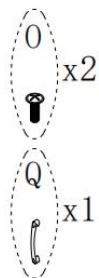
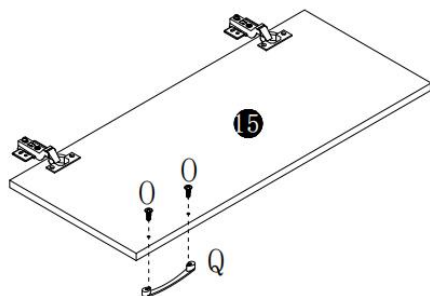

22

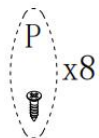
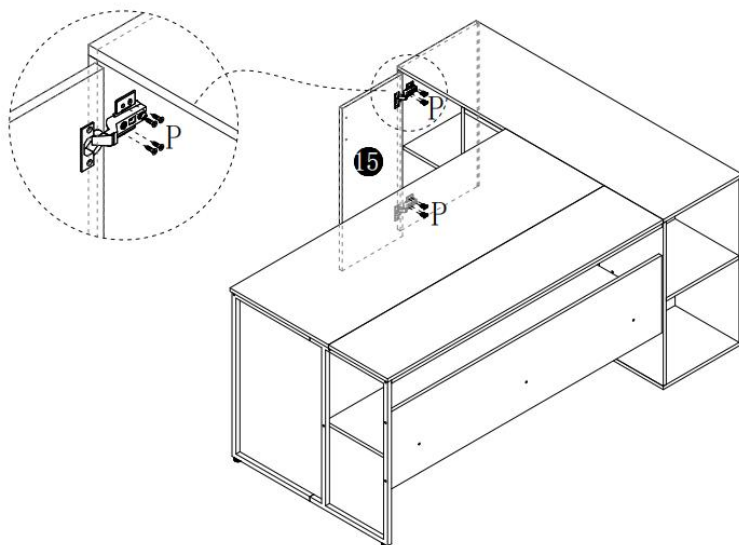

543

ASSEMBLY STEP

23

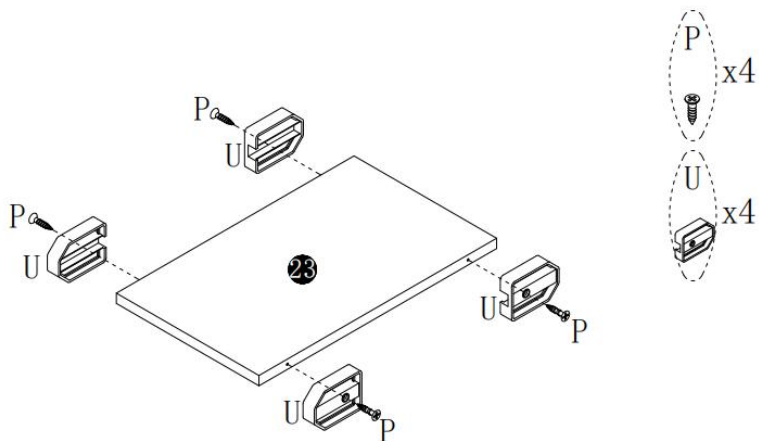

24

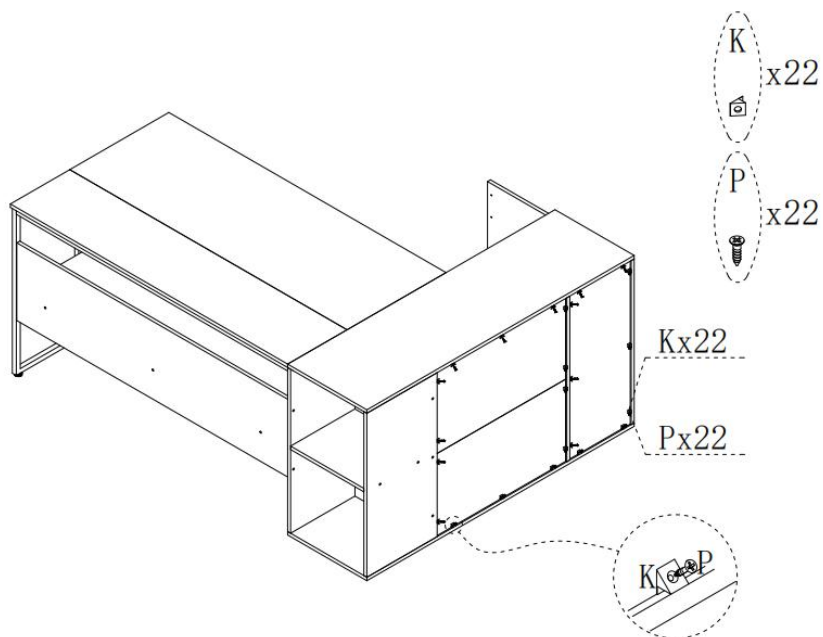

ASSEMBLY STEP

25

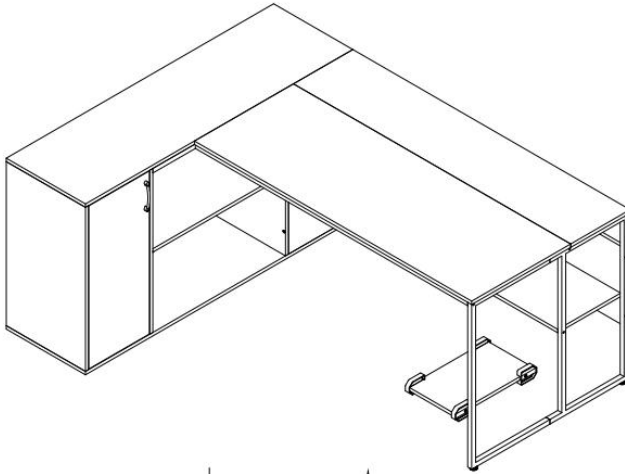

↓
OR
↑

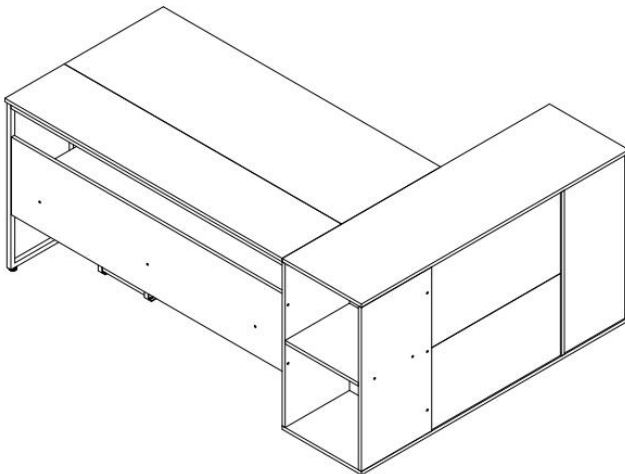

PRODUCT PARAMETER

Modelo	C25024 3 D-01
Peso de carga seguro	350 libras
Tamaño del producto (D*An*Al)	1800 * 800 * 750mm

* Los productos como las especificaciones, la apariencia y el diseño están sujetos a modificaciones sin previo aviso.

Fabricante: Shanghaimuxinmuyeyouxiangongsi

Dirección: Shuangchenglu 803nong11hao1602A-1609shi, baoshanqu, shanghai 200000 CN.

Importado a AUS: SIHAO PTY LTD. 1 ROKEVA STREET, EASTWOOD, NSW 2122, Australia

Importado a EE. UU.: Sanven Technology Ltd. Suite 250, 9166 Anaheim Place, Rancho Cucamonga, CA 91730

EC	REP
-----------	------------

E-CrossStu GmbH
Mainzer Landstr.69, 60329 Frankfurt am Main.

UK	REP
-----------	------------

YH CONSULTING LIMITED.
C/O YH Consulting Limited Office 147, Centurion House, London Road, Staines-upon-Thames, Surrey, TW18 4AX



VEVOR

Affordable. Reliable. Home Improvement.

BIURKO KIEROWNICZE

MODEL: C250243D-01

VEVOR

Affordable. Reliable. Home Improvement.

EXECUTIVE DESK

MODEL: C25024 3 D-01

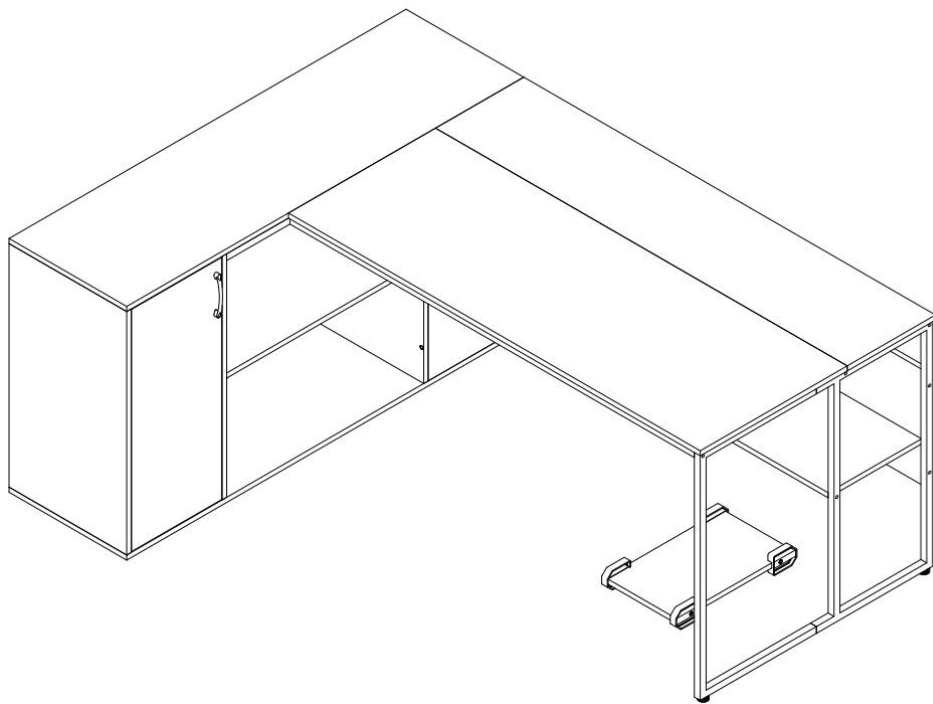

To jest oryginalna instrukcja obsługi. Przed użyciem prosimy o dokładne zapoznanie się z treścią instrukcji. Firma VEVOR zastrzega sobie prawo do jednoznacznej interpretacji niniejszej instrukcji obsługi. Wygląd produktu zależy od stanu, w jakim go otrzymali Państwo. Prosimy o wyrozumiałość, ale nie będziemy Państwa ponownie informować o aktualizacjach technologicznych lub oprogramowania naszego produktu.

SAFETY INSTRUCTIONS

WSTĘP

Dziękujemy za zakup naszych produktów. Naszym życiowym celem zawsze było zapewnienie klientom produktów i usług najwyższej jakości. Przed użyciem produktu prosimy o zapoznanie się z treścią instrukcja obsługi ostrożnie, aby zapewnić prawidłowe użytkowanie. Przechowuj instrukcję obsługi w miejscu gdzie użytkownik może je znaleźć w dowolnym momencie.

MONTAŻ ŚRODKI OSTROŻNOŚCI

Jest ich wiele elementy i akcesoria w opakowaniu. Każdy element i akcesorium są oznaczone literą lub cyfrą, sprawdź Przed użyciem któregokolwiek z nich należy zachować ostrożność. Trzymaj je z dala od dzieci zapobiegać wypadkom.

56. Montaż należy wykonywać wyłącznie zgodnie z niniejszą instrukcją. Nieprawidłowy montaż może stwarzać zagrożenie.
57. Podczas montażu należy nosić okulary ochronne zatwierdzone przez ANSI oraz wytrzymałe rękawice robocze.
58. Utrzymuj miejsce zgromadzenia w czystości i zapewnij dobre oświetlenie.
59. Nie dopuszczać osób postronnych na teren montażu w trakcie jego trwania.
60. Nie przychodź na zgromadzenie, jeśli jesteś zmęczony lub pod wpływem alkoholu, narkotyków lub leków.
61. Możliwości produktu odnoszą się wyłącznie do produktów prawidłowo i całkowicie zmontowanych.
62. Proszę zainstalować produkt na czystym i miękkim podkładzie (np. dywanie) lub tektury), aby uniknąć zarysowania lub uszkodzenia powierzchni produkt .
63. Jeżeli to możliwe, możesz użyć elektronarzędzi, aby ułatwić sobie montaż.
64. Główne elementy produktu są stosunkowo ciężkie. Proszę o zapłatę

należy zachować szczególną ostrożność podczas instalacji .

65. Produkt nie jest stabilny podczas montażu. Nie należy go przenosić losowo. przed całkowitym zainstalowaniem .

66. Aby uzyskać dodatkowe informacje dotyczące części wymienionych poniżej

stron, zapoznaj się ze schematem montażu w niniejszej instrukcji.

Rozpakuj i oddziel wszystkie części w czystym miejscu pracy.

***PAMIĘTAJ O POSTĘPOWANIU ZGODNIE Z INSTRUKCJĄ
INSTRUKCJI INSTALACJI, UNIKNIJ NIEPOTRZEBNYCH STRAT
SPOWODOWANYCH NIEWŁAŚCIWĄ INSTALACJĄ.
UŻYWAĆ ŚRODKI OSTROŻNOŚCI**

21) Nie przekraczać określonej wartości nośności.

22) Używać wyłącznie na płaskiej, równej, twardej i gładkiej powierzchni, która może bezpiecznie utrzymać w pełni załadowane biurko kierownicze.

23) Stosować wyłącznie zgodnie z przeznaczeniem.







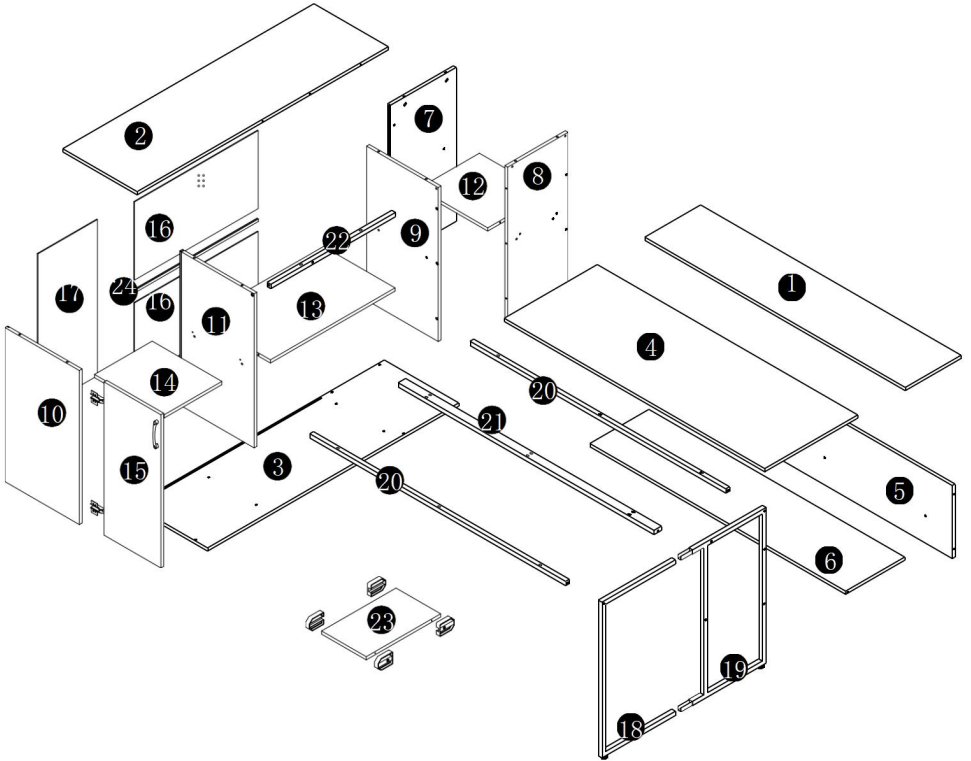







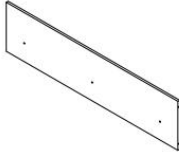

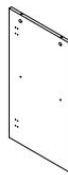

24) Przed każdym użyciem należy przeprowadzić kontrolę. Nie używać produktu, jeśli części są luźne lub uszkodzone.

ZAPISZ TĘ INSTRUKCJĘ



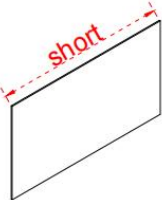
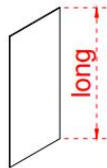

EXPLODED VIEW



















PARTS LIST

 <p>1 1pc</p>	 <p>2 1pc</p>	 <p>3 1pc</p>	 <p>4 1pc</p>
 <p>5 1pc</p>	 <p>6 1pc</p>	 <p>7 1pc</p>	 <p>8 1pc</p>
 <p>9 1pc</p>	 <p>10 1pc</p>	 <p>11 1pc</p>	 <p>12 1pc</p>
 <p>13 1pc</p>	 <p>14 1pc</p>	 <p>15 1pc</p>	 <p>16 2pcs</p>
 <p>17 1pc</p>	 <p>18 1pc</p>	 <p>19 1pc</p>	 <p>20 2pcs</p>

PARTS LIST

			
21 1pc	22 1pc	23 1pc	24 1pc

 M6X40MM A 14pcs	 M7X50MM B 34pcs	 C 14pcs	 M6X30MM F 14pcs	 M6X40MM H 8pcs
 K 22pcs	 M6X10MM N 4pcs	 M4X18MM O 2pcs	 ST3. 5X12MM P 38pcs	 Q 1pc
 DWX15MM T 2pcs	 U 4pcs	 X 3pcs	 M8X14MM Y 2pcs	 1pc
				

Montaż krzywek i sworzni

Wkręć sworznię w otwór. Aby prawidłowo ustawić krzywkę, upewnij się, że strzałka na krzywce jest skierowana w stronę otworu blokującego sworzni. Zablockuj krzywkę, obracając głowicę krzywki śrubokrętem, aż będzie dokręcona. Nie używaj wkrętarki elektrycznej do montażu. jednostka.

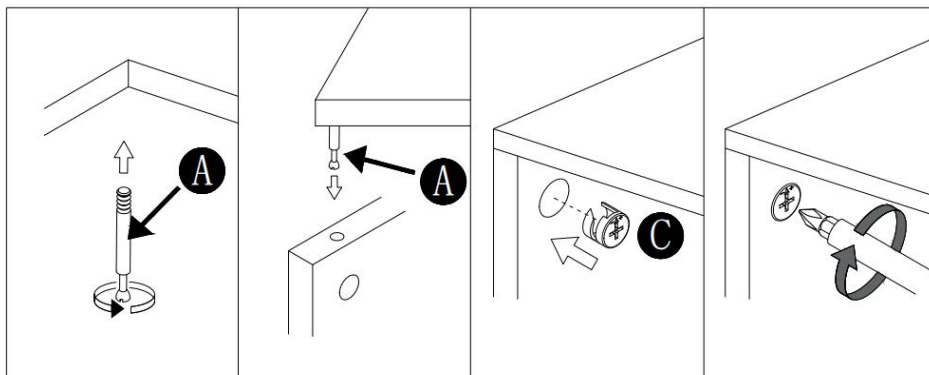

Przed rozpoczęciem pracy należy uważnie przeczytać każdy krok. Bardzo ważne jest, aby każdy krok instrukcji został wykonany we właściwej kolejności. Jeśli kroki te nie zostaną wykonane w odpowiedniej kolejności, mogą wystąpić problemy z montażem. wystąpić.

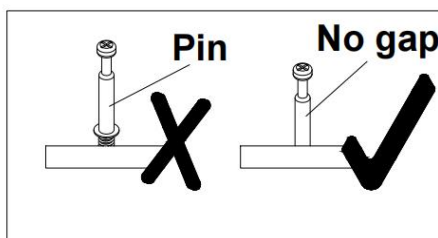

ASSEMBLY STEP

1

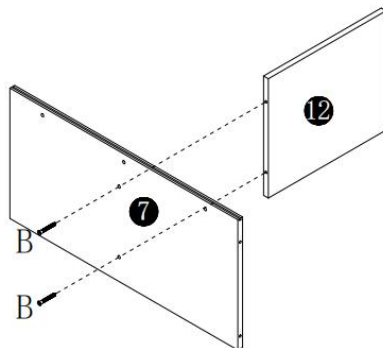
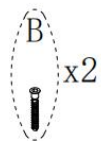

2

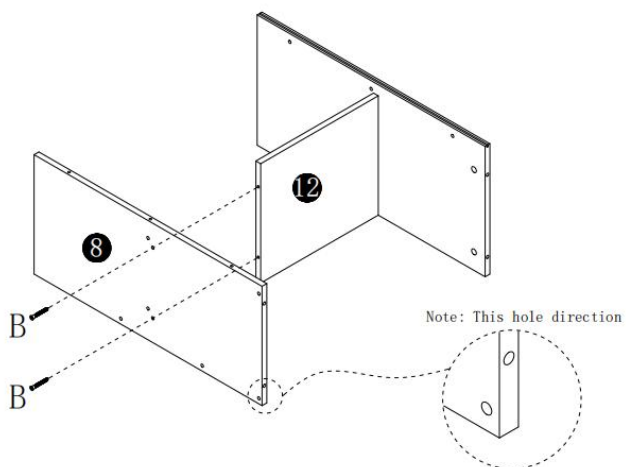
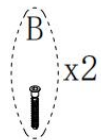

ASSEMBLY STEP

3

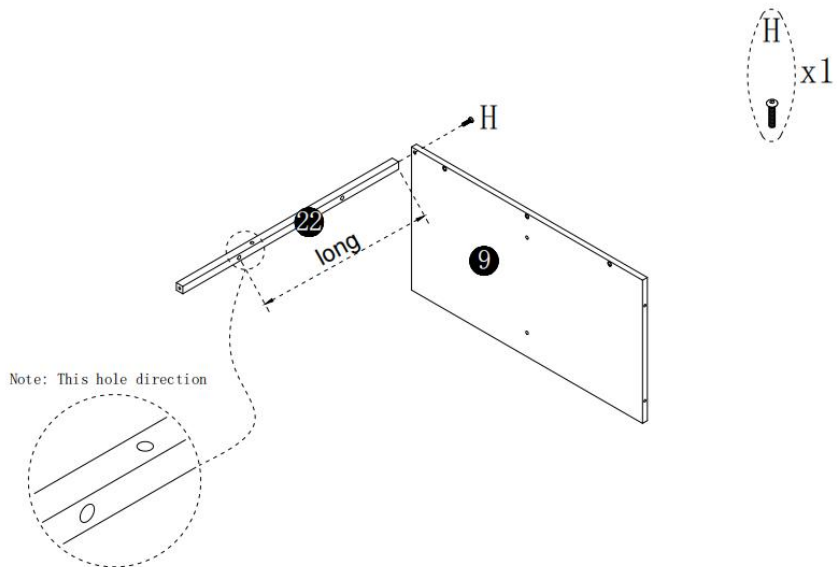

4

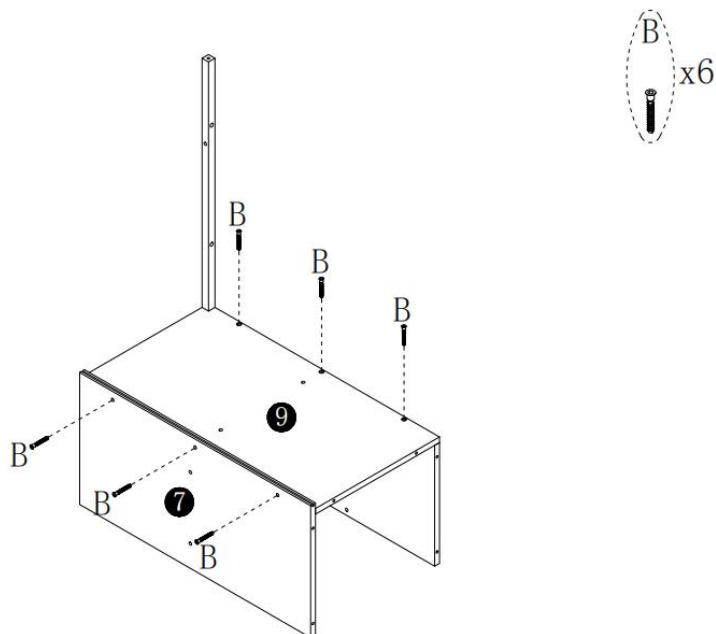

ASSEMBLY STEP

5

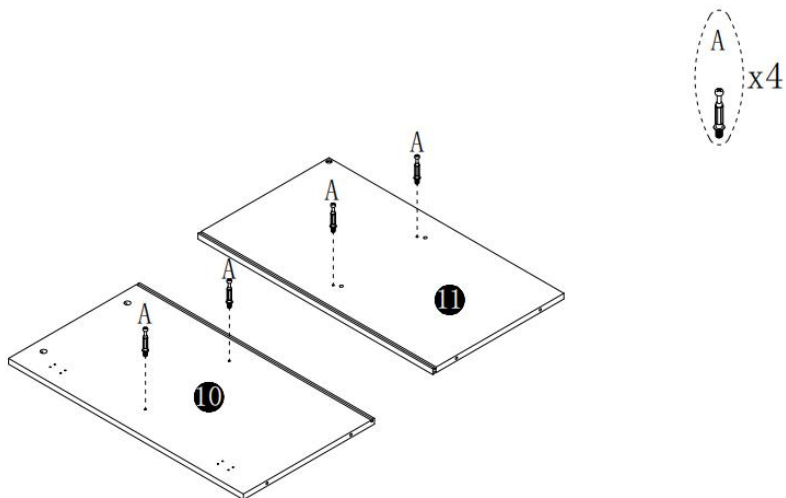

6

Note: This hole direction

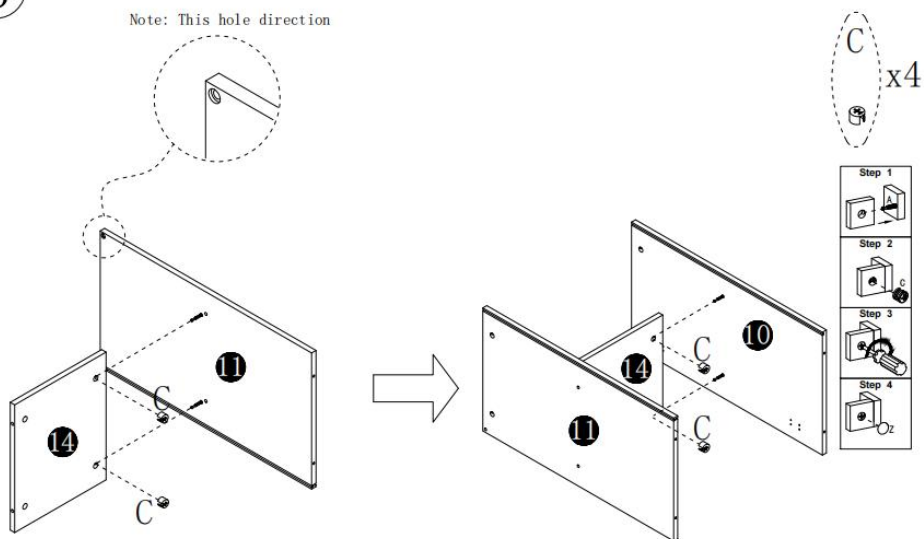

ASSEMBLY STEP

7

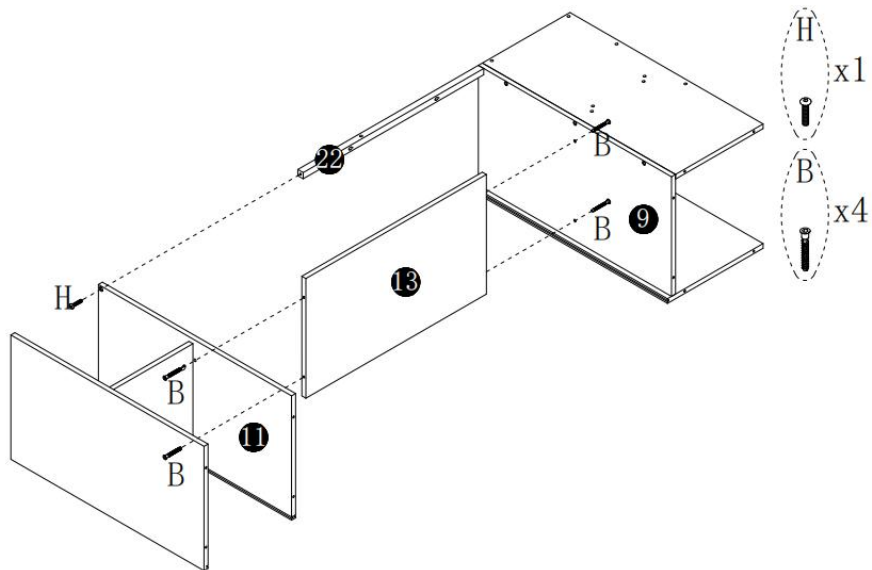

8

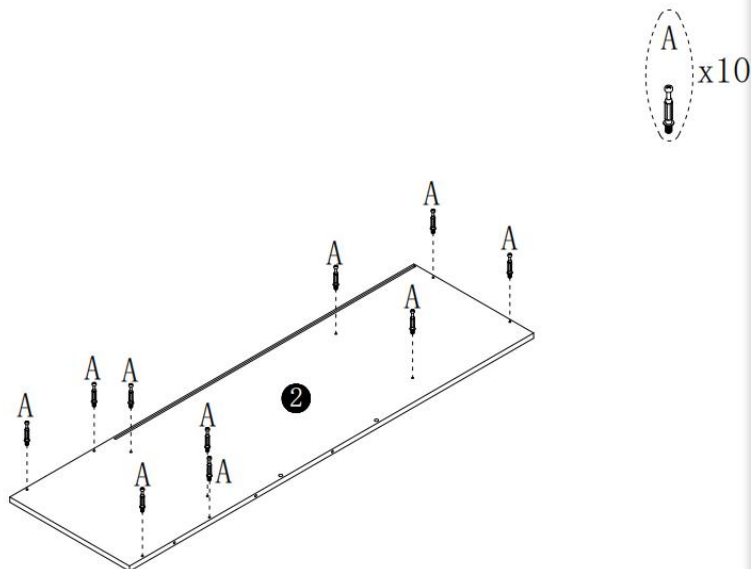

ASSEMBLY STEP

9

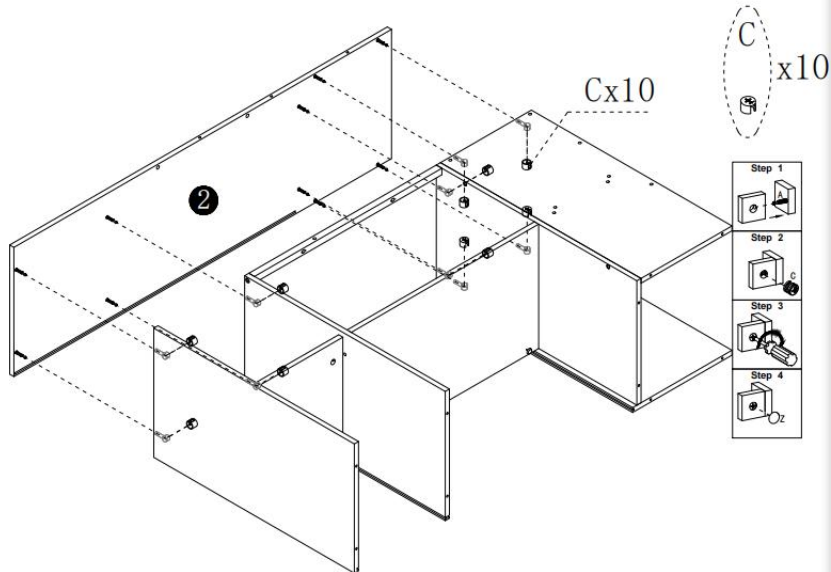

10

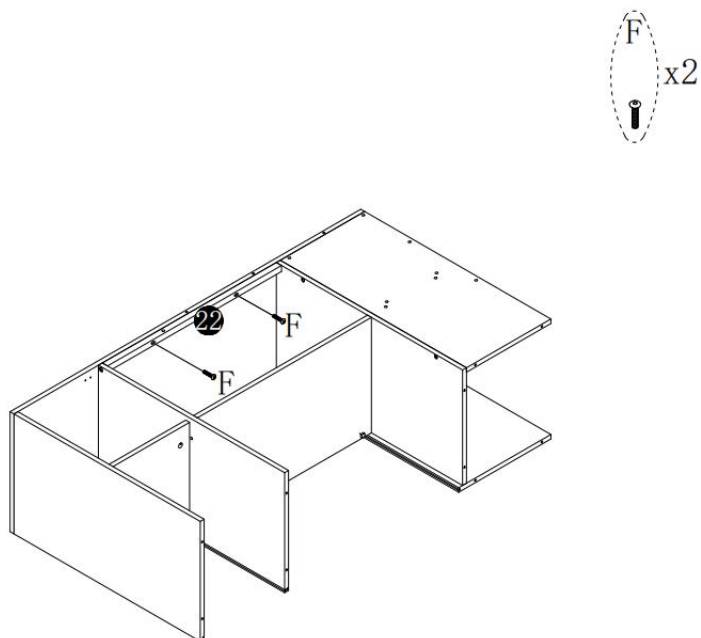

ASSEMBLY STEP

11

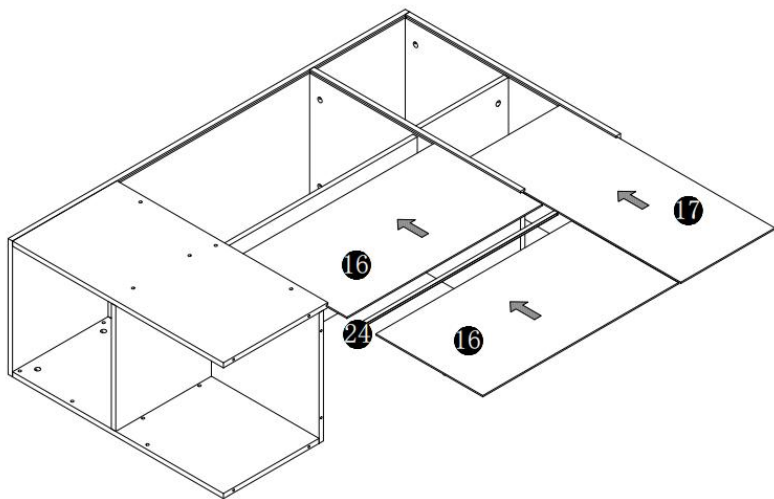

12

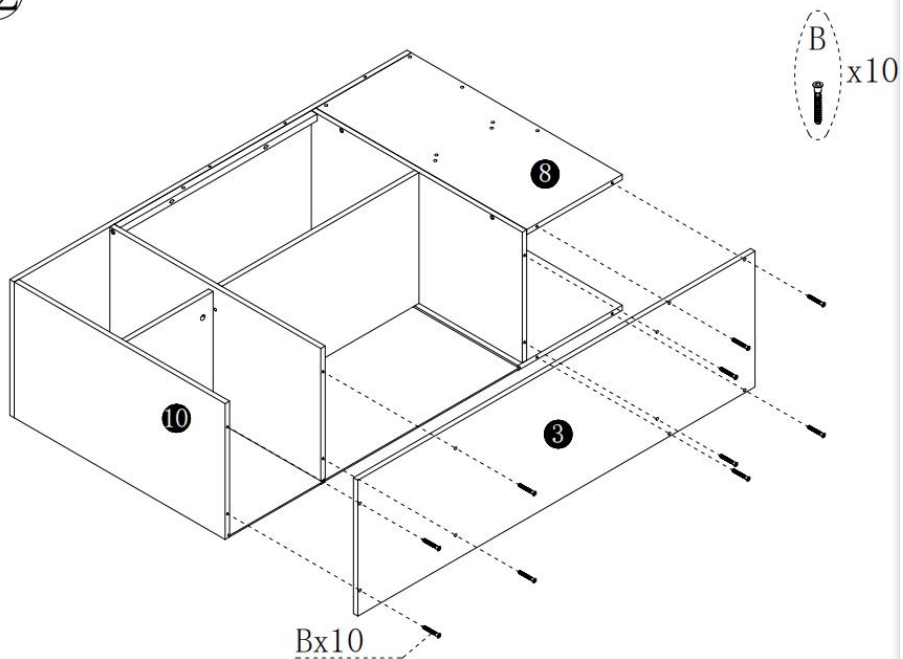

ASSEMBLY STEP

13

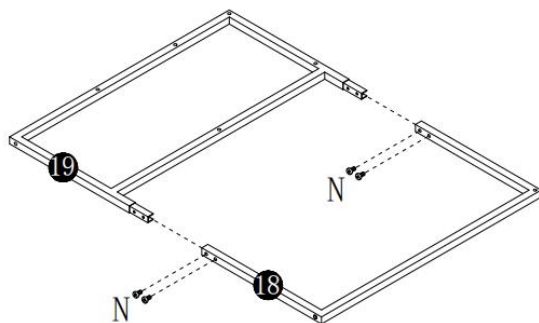
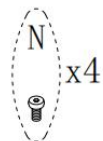

14

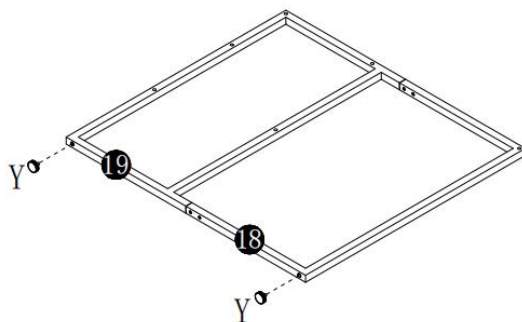
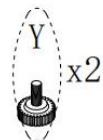

ASSEMBLY STEP

15

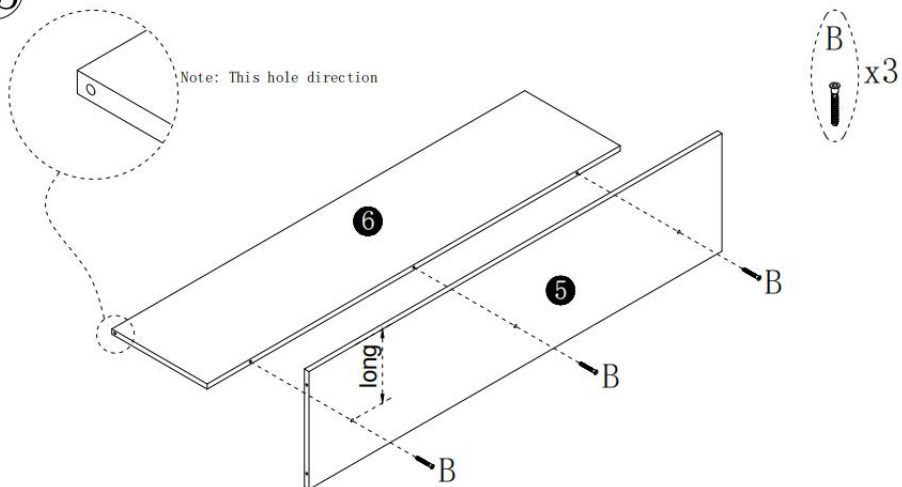

16

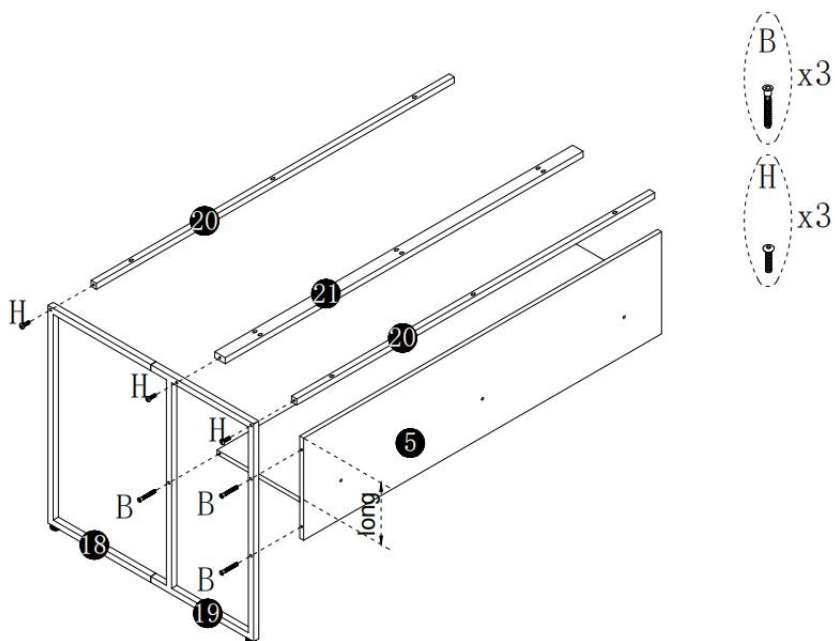

ASSEMBLY STEP

17

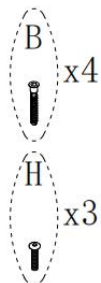
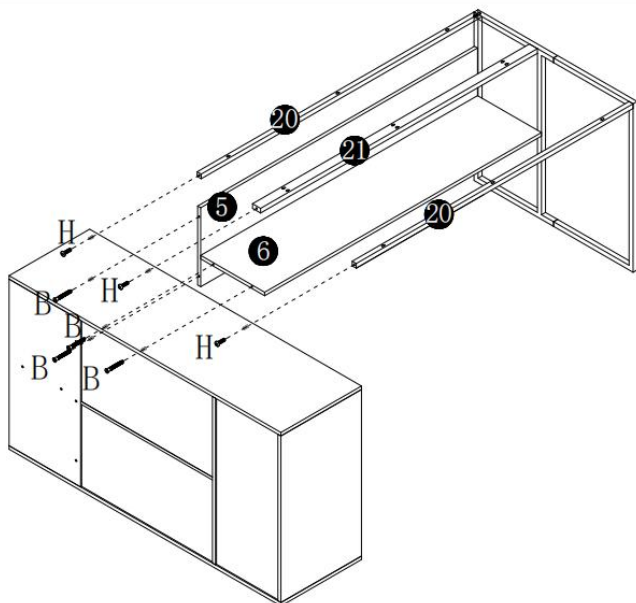

18

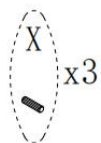
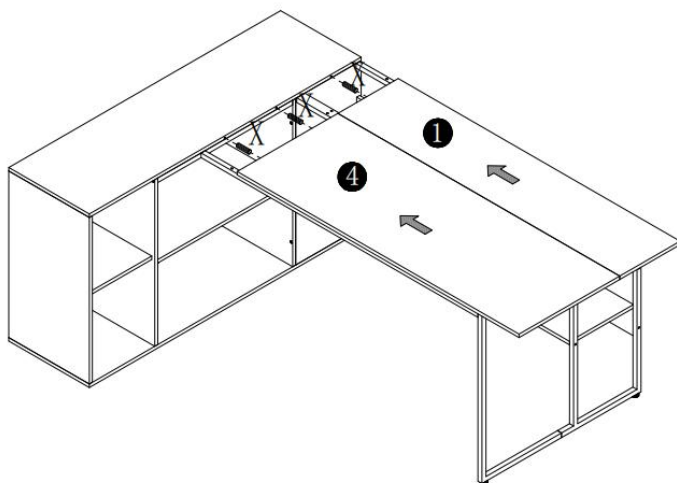

ASSEMBLY STEP

19

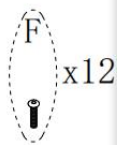
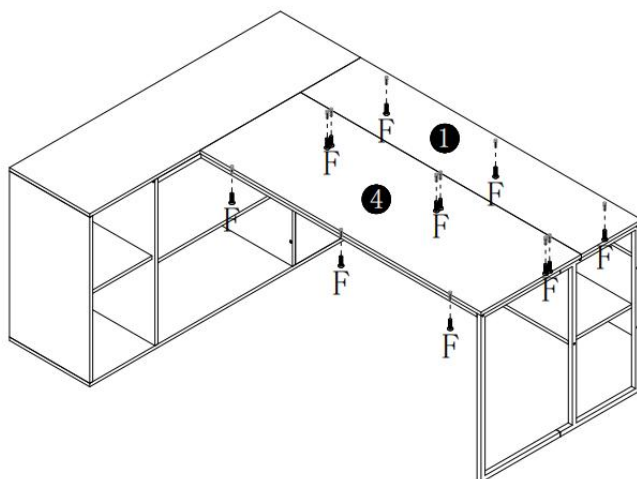

20

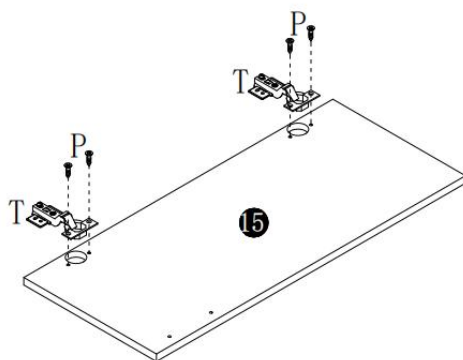

ASSEMBLY STEP

21

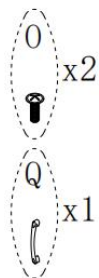
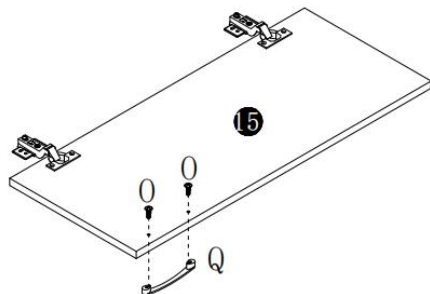

22

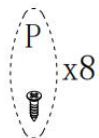
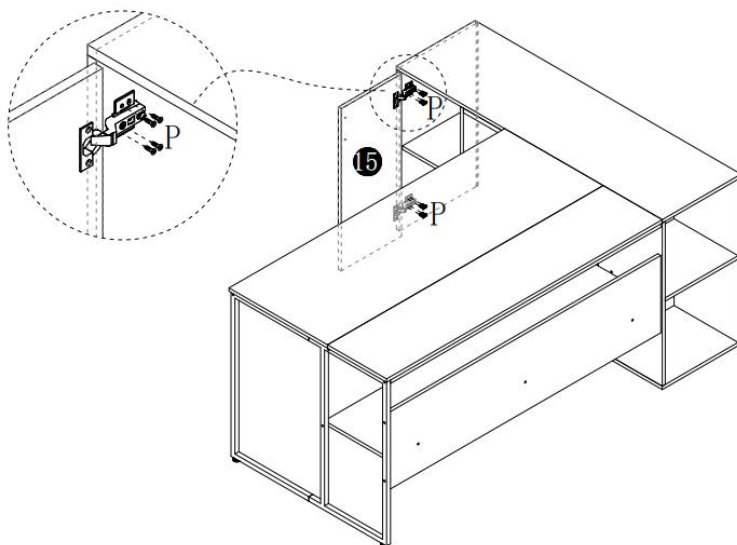

ASSEMBLY STEP

23

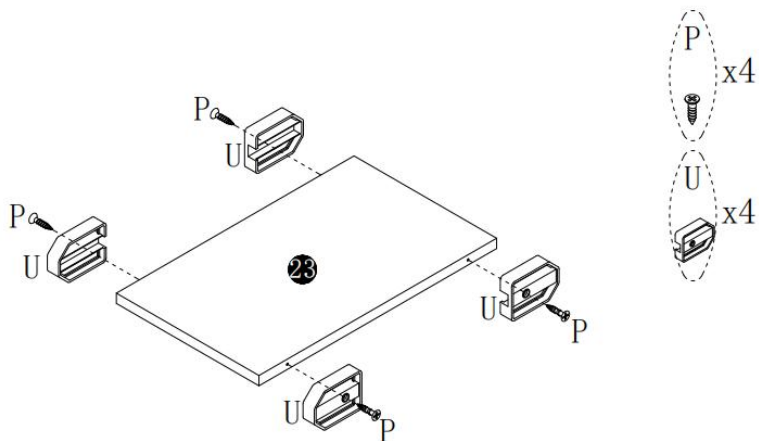

24

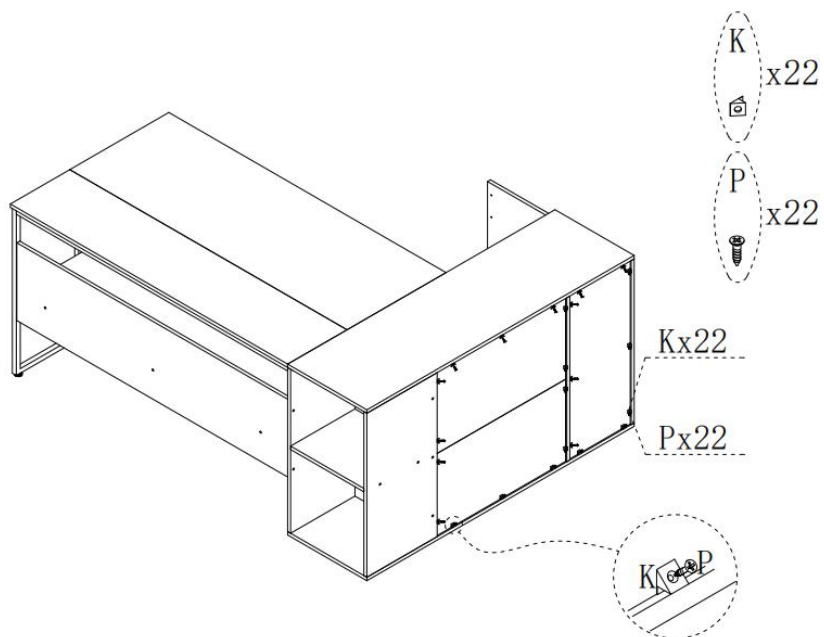

ASSEMBLY STEP

25

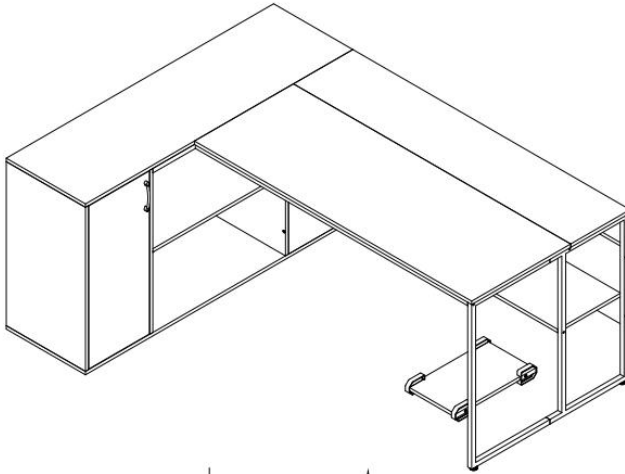

↓
OR
↑

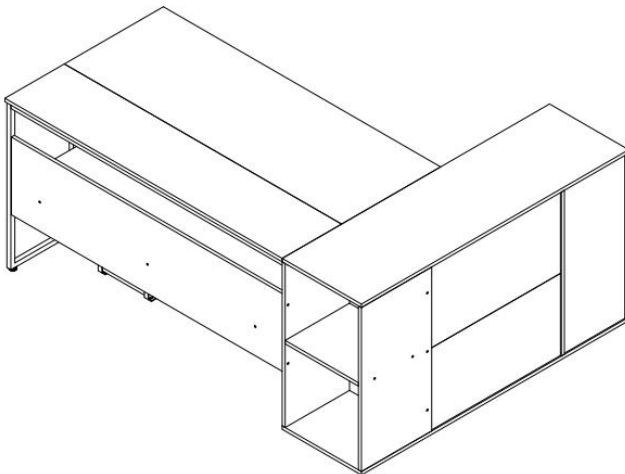

PRODUCT PARAMETER

Model	C25024 3 D-01
Bezpieczna waga załadunku	350 funtów
Wymiary produktu (gł.*szer.*wys.)	1 8 00* 80 0* 75 0mm

* Produkty mogą podlegać zmianom dotyczącym specyfikacji, wyglądu i konstrukcji bez wcześniejszego powiadomienia.

Producent: Shanghaimuxinmuyeyouxiangongsi

Adres: Shuangchenglu 803nong11hao1602A-1609shi, baoshanqu, szanghaj 200000 CN.

Importowane do Australii: SIHAO PTY LTD. 1 ROKEVA
STREETEASTWOOD NSW 2122 Australia

Importowane do USA: Sanven Technology Ltd. Suite 250, 9166 Anaheim
Place, Rancho Cucamonga, CA 91730

EC	REP
-----------	------------

E-CrossStu GmbH
Mainzer Landstr.69, 60329 Frankfurt am Main.

UK	REP
-----------	------------

YH CONSULTING LIMITED.
C/O YH Consulting Limited Office 147, Centurion
House, London Road, Staines-upon-Thames, Surrey,
TW18 4AX



VEVOR

Affordable. Reliable. Home Improvement.

DIRECTIEBUREAU

MODEL: C250243D-01

VEVOR

Affordable. Reliable. Home Improvement.

EXECUTIVE DESK

MODEL: C25024 3 D-01

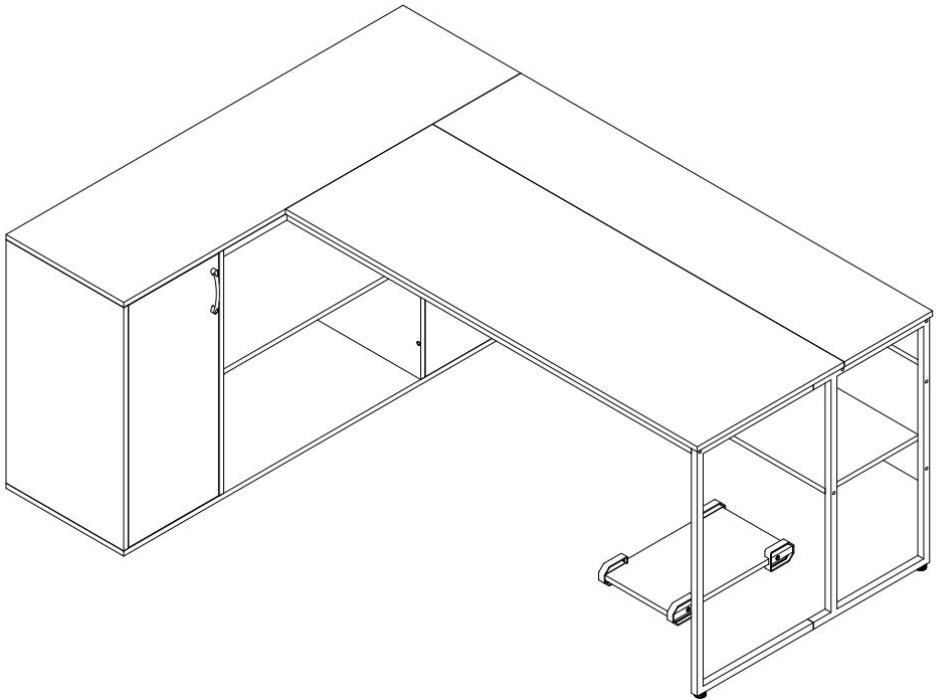

Dit is de originele handleiding. Lees alle instructies zorgvuldig door voordat u het product gebruikt. VEVOR behoudt zich het recht voor om de gebruiksaanwijzing duidelijk te interpreteren. Het uiterlijk van het product is afhankelijk van het product dat u hebt ontvangen. Neemt u het ons niet kwalijk dat we u niet meer op de hoogte stellen van eventuele technologische of software-updates voor ons product.

SAFETY INSTRUCTIONS

INVOERING

Bedankt voor uw aankoop van onze producten. Ons doel is altijd geweest om onze klanten de beste kwaliteit producten en service te bieden. Lees dit aandachtig door voordat u het product gebruikt. Gebruiksaanwijzing zorgvuldig door om correct gebruik te garanderen. Bewaar de gebruiksaanwijzing op een plaats waar de gebruiker deze op elk gewenst moment kan vinden.

MONTAGE VOORZORGSMATREGELEN

Er zijn er veel componenten en accessoires in het pakket. Elk Als een onderdeel of accessoire is gemarkeerd met een letter of een cijfer, controleer dan zorgvuldig door voordat u ze gebruikt. Houd ze buiten bereik van kinderen. ongelukken voorkomen.

67. Monteer het product uitsluitend volgens deze instructies. Onjuiste montage kan gevaarlijk zijn.
68. Draag tijdens de montage een ANSI-goedgekeurde veiligheidsbril en stevige werkhandschoenen.
69. Houd de verzamelplaats schoon en goed verlicht.
70. Houd omstanders tijdens de montage uit de buurt.
71. Kom niet in actie als u moe bent of onder invloed van alcohol, drugs of medicijnen.
72. De producteigenschappen gelden uitsluitend voor correct en volledig gemonteerde producten.
73. Installeer het product op een schone en zachte ondervloer (zoals tapijt). of karton) om krassen of beschadigingen aan het oppervlak van de product .
74. Indien mogelijk kunt u elektrisch gereedschap gebruiken om de montage te vergemakkelijken.
75. De hoofdcomponenten van het product zijn relatief zwaar. Betaal alstublieft aandacht voor veiligheid tijdens de installatie .
76. Het product is niet stabiel tijdens de installatie. Verplaats het niet

willekeurig. voordat het volledig is geïnstalleerd .

77. Voor aanvullende informatie over de onderdelen die in de volgende lijst staan vermeld:

Voor meer informatie over de montage, zie het montageschema van deze handleiding. Uitpakken en scheid alle onderdelen in een schone werkruimte.

***VOLG DE INSTALLATIESTAPPEN IN DE HANDLEIDING OM VOORKOM ONNODIGE VERLIEZEN ALS GEVOLG VAN ONJUISTE INSTALLATIE.**

GEBRUIK VOORZORGSMAATREGELEN







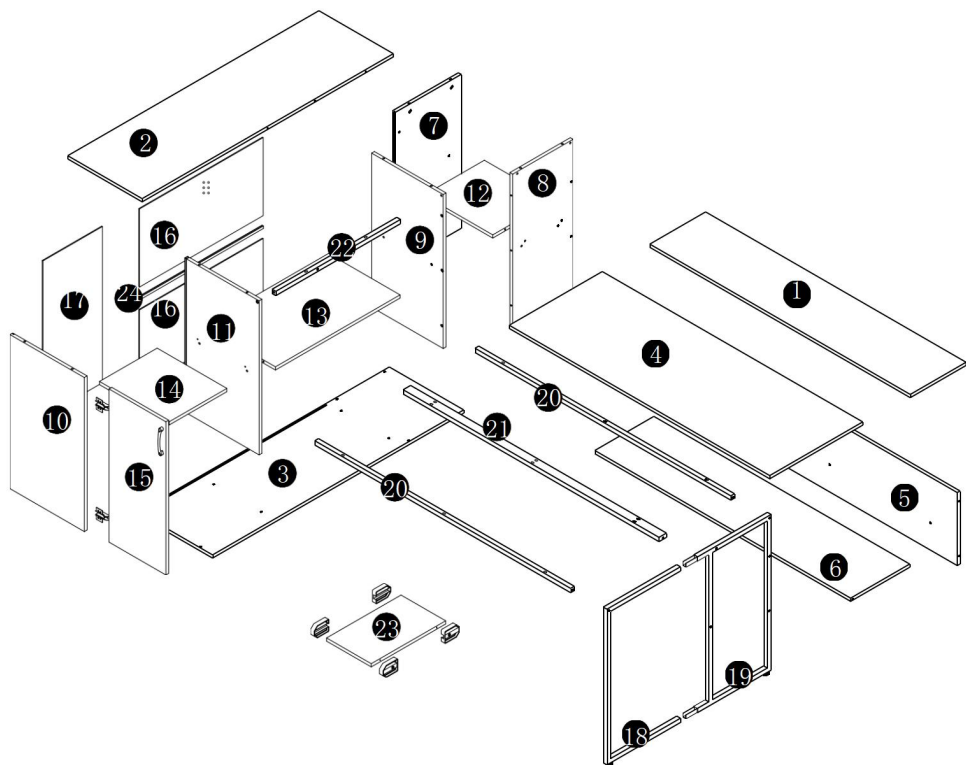







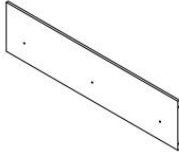

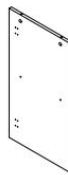

- 25) Niet overschrijden aangegeven gewichtscapaciteiten.
- 26) Gebruik het product alleen op een vlak, egaal, hard en glad oppervlak dat een volledig beladen directiebureau veilig kan dragen.
- 27) Alleen gebruiken zoals bedoeld.
- 28) Controleer het product voor elk gebruik. Niet gebruiken als er onderdelen loszitten of beschadigd zijn.

BEWAAR DEZE HANDLEIDING



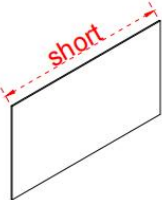
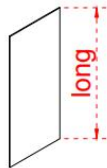

EXPLODED VIEW



















PARTS LIST

 <p>1 1pc</p>	 <p>2 1pc</p>	 <p>3 1pc</p>	 <p>4 1pc</p>
 <p>5 1pc</p>	 <p>6 1pc</p>	 <p>7 1pc</p>	 <p>8 1pc</p>
 <p>9 1pc</p>	 <p>10 1pc</p>	 <p>11 1pc</p>	 <p>12 1pc</p>
 <p>13 1pc</p>	 <p>14 1pc</p>	 <p>15 1pc</p>	 <p>16 2pcs</p>
 <p>17 1pc</p>	 <p>18 1pc</p>	 <p>19 1pc</p>	 <p>20 2pcs</p>

PARTS LIST

			
21 1pc	22 1pc	23 1pc	24 1pc

 M6X40MM A 14pcs	 M7X50MM B 34pcs	 C 14pcs	 M6X30MM F 14pcs	 M6X40MM H 8pcs
 K 22pcs	 M6X10MM N 4pcs	 M4X18MM O 2pcs	 ST3. 5X12MM P 38pcs	 Q 1pc
 DWX15MM T 2pcs	 U 4pcs	 X 3pcs	 M8X14MM Y 2pcs	 1pc
				

Installatie van nokken en pennen

Schroef de pen in het gat. Om de nokken correct te plaatsen, zorg ervoor dat de pijl op de nok naar het gat van de pen wijst die hij blokkeert. Vergrendel de nok door de nokkop met een schroevendraaier te draaien totdat deze vastzit. Gebruik geen elektrische schroevendraaier om de nokken te monteren. eenheid.

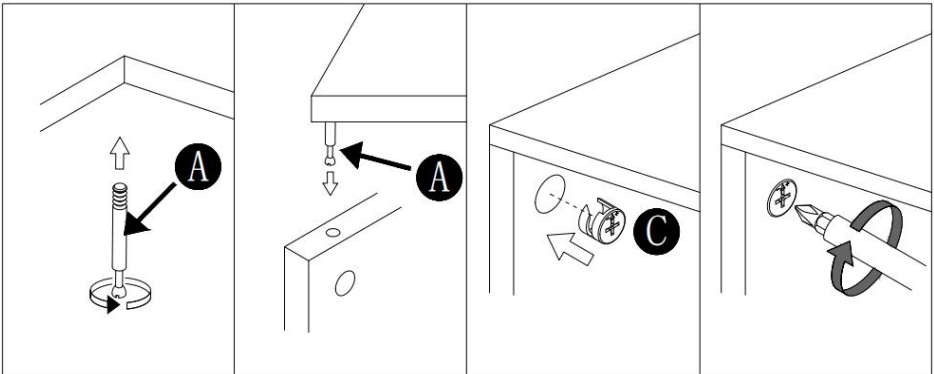

Lees elke stap zorgvuldig door voordat u begint. Het is erg belangrijk dat elke stap van de instructie in de juiste volgorde wordt uitgevoerd. Als deze stappen niet in de juiste volgorde worden gevolgd, kunnen er montageproblemen ontstaan. optreden.!

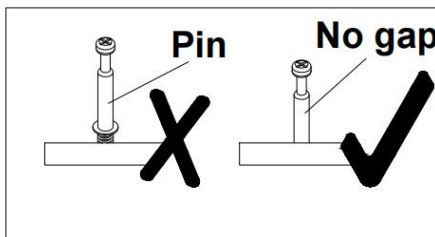

ASSEMBLY STEP

1

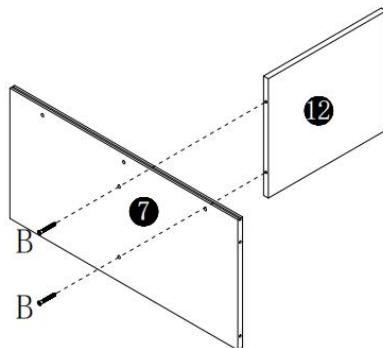
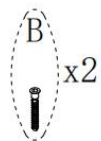

2

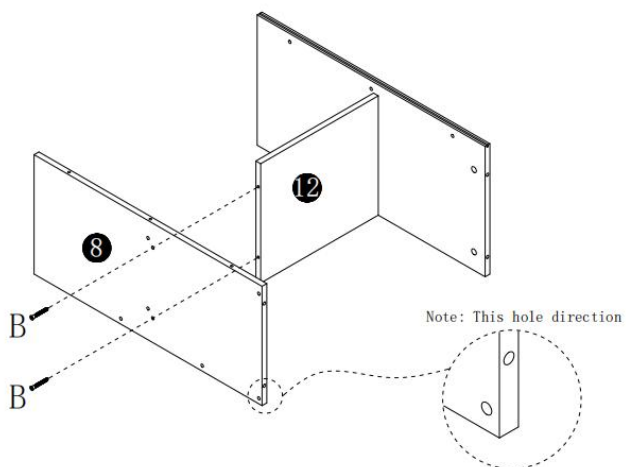
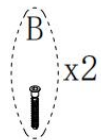

ASSEMBLY STEP

3

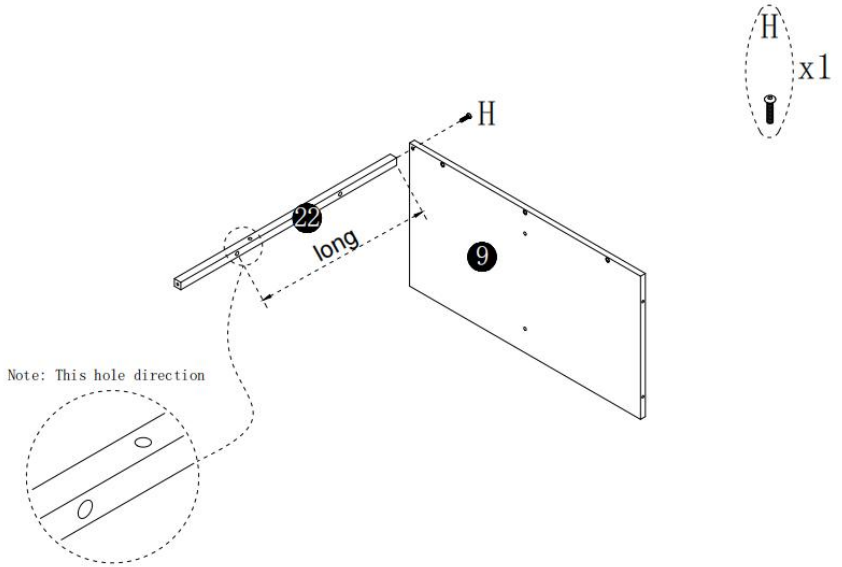

4

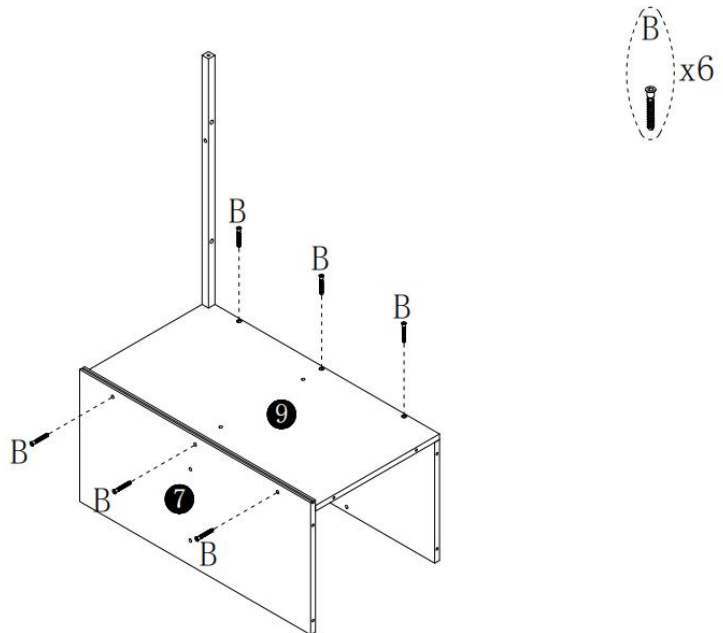

ASSEMBLY STEP

5

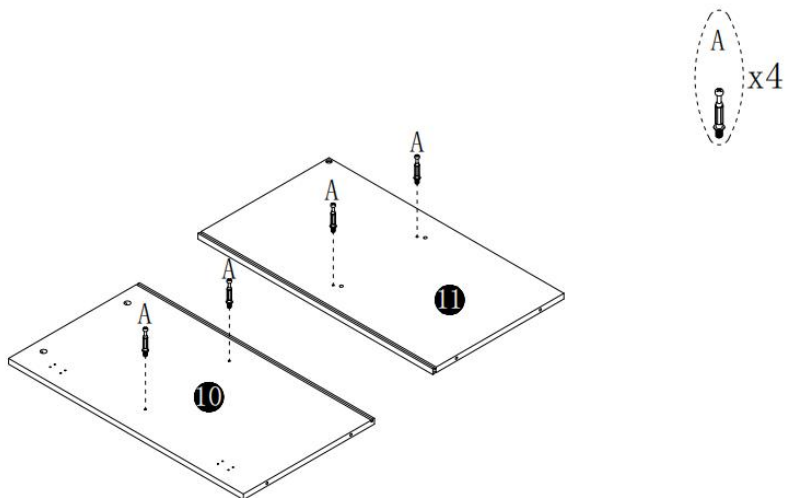

6

Note: This hole direction

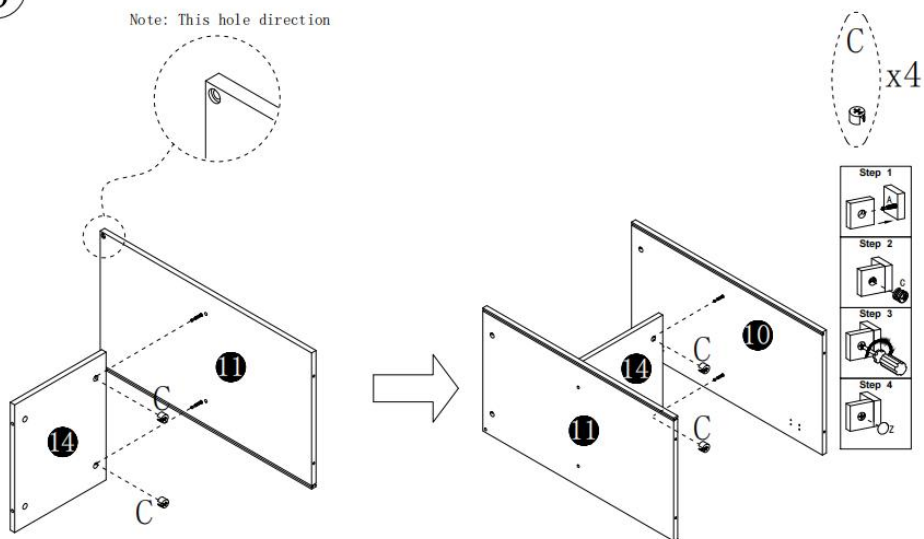

ASSEMBLY STEP

7

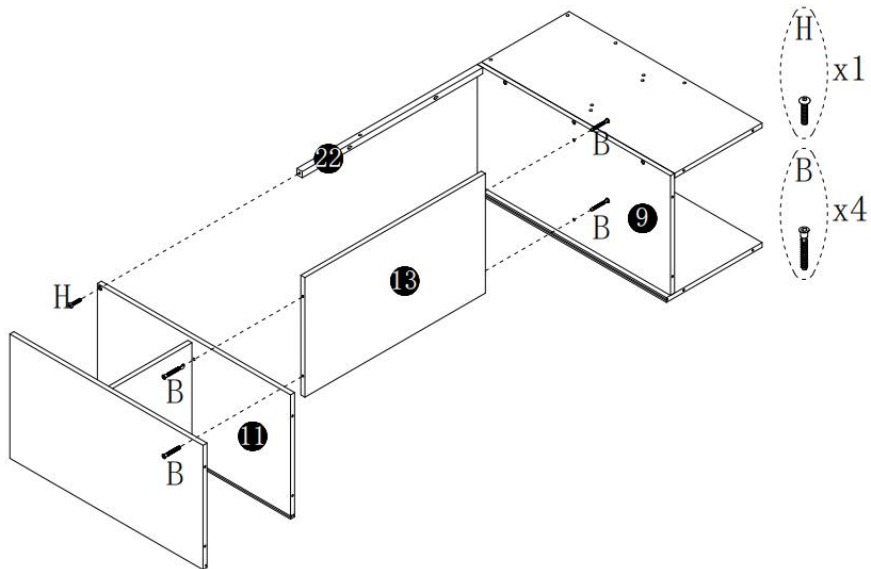

8

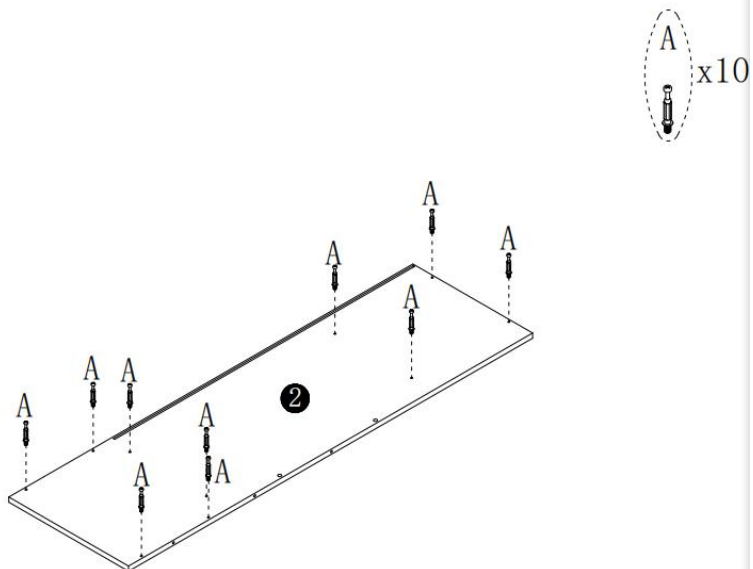

ASSEMBLY STEP

9

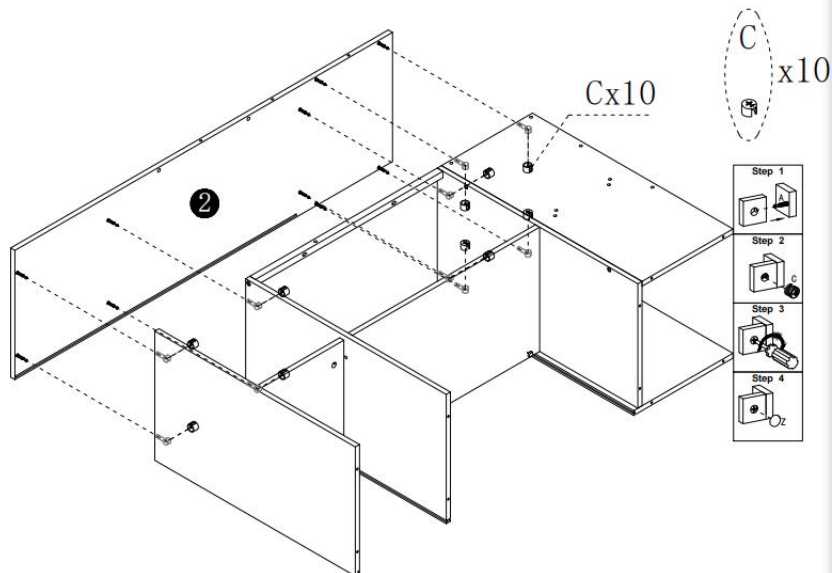

10

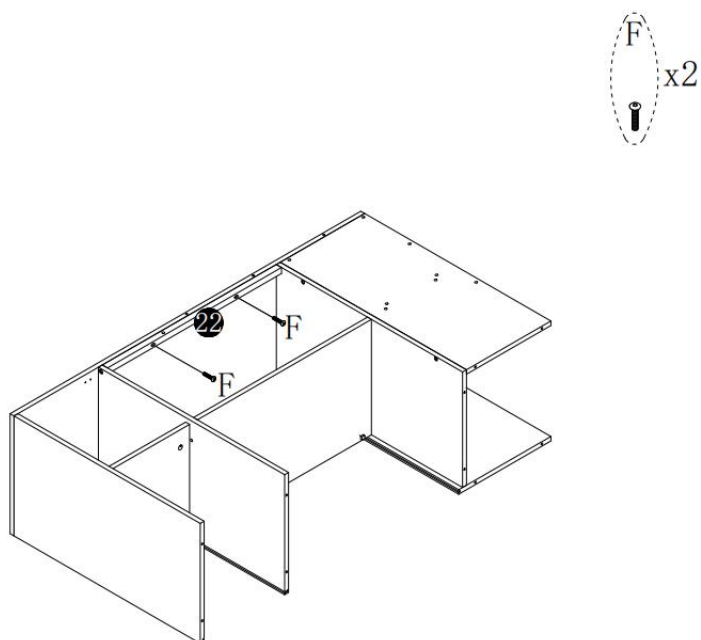

ASSEMBLY STEP

11

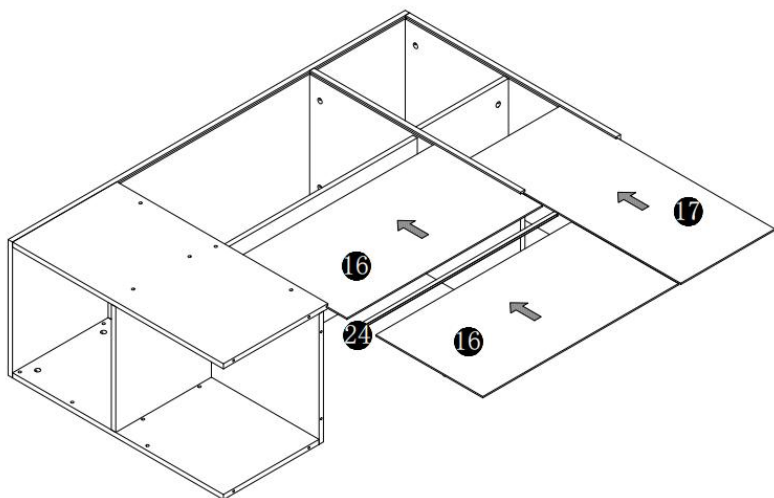

12

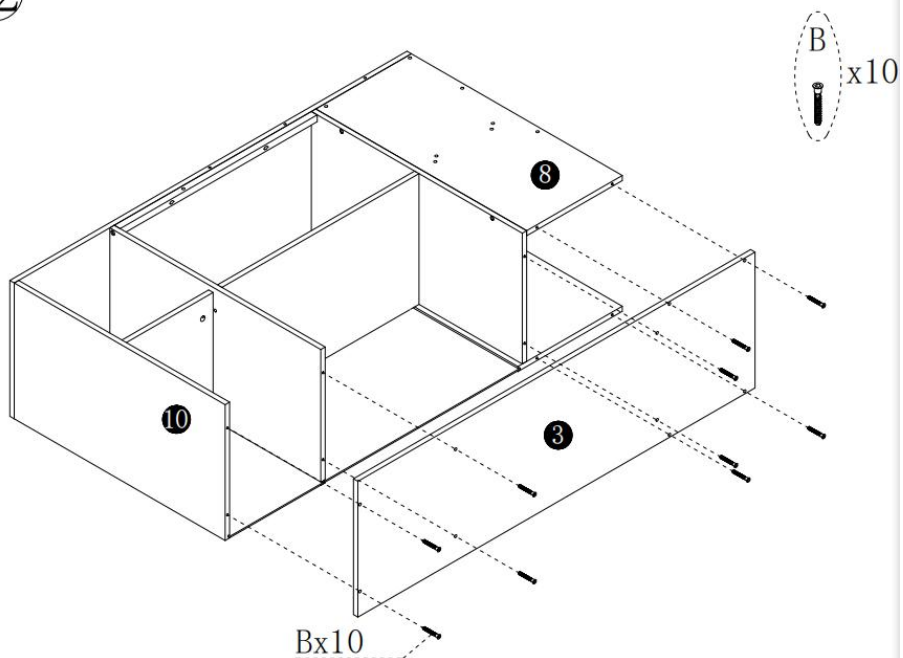

ASSEMBLY STEP

13

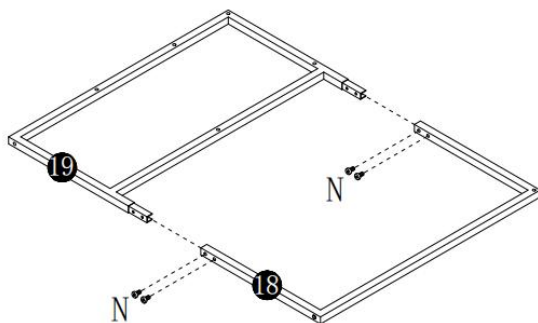
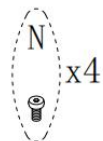

14

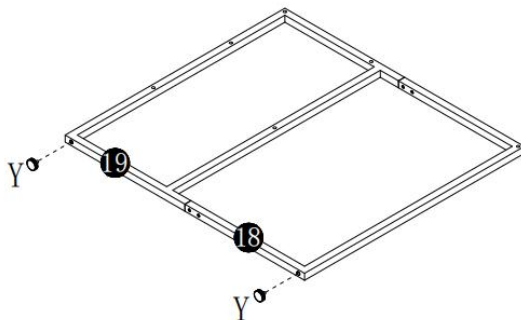
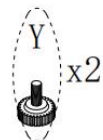

ASSEMBLY STEP

15

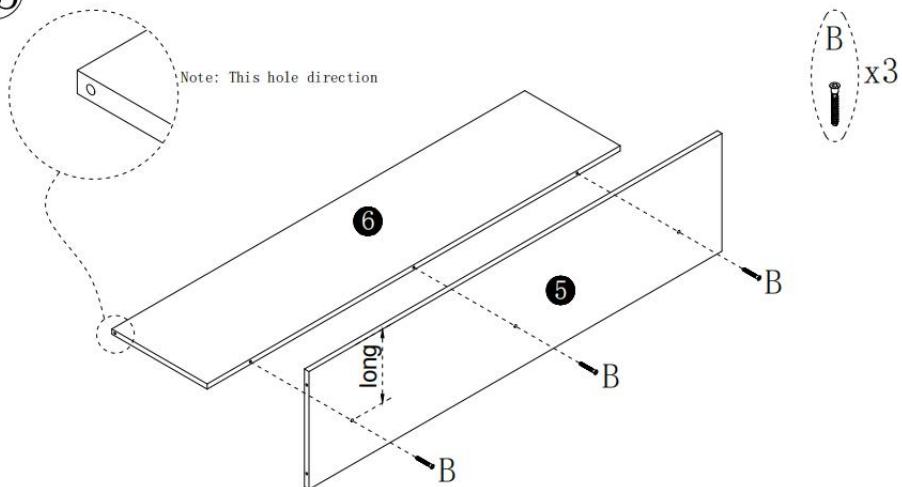

16

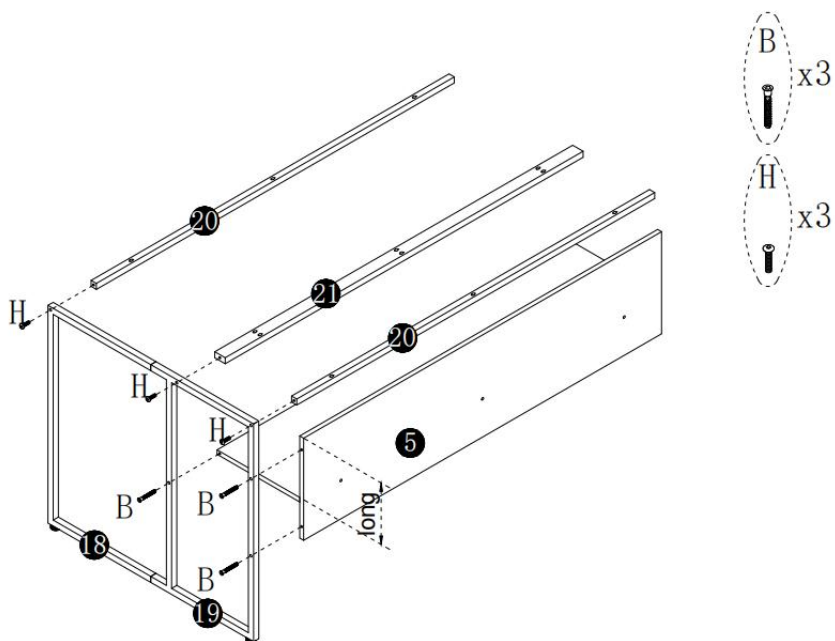

ASSEMBLY STEP

17

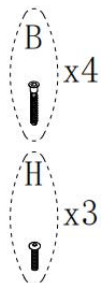
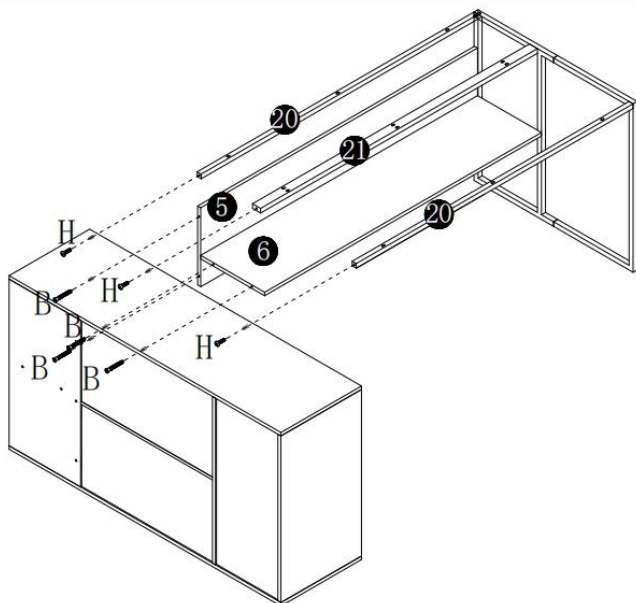

18

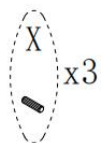
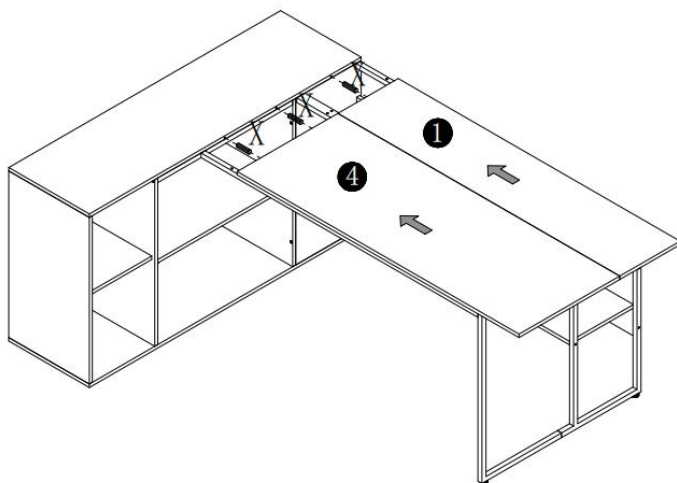

ASSEMBLY STEP

19

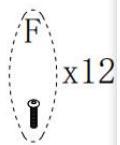
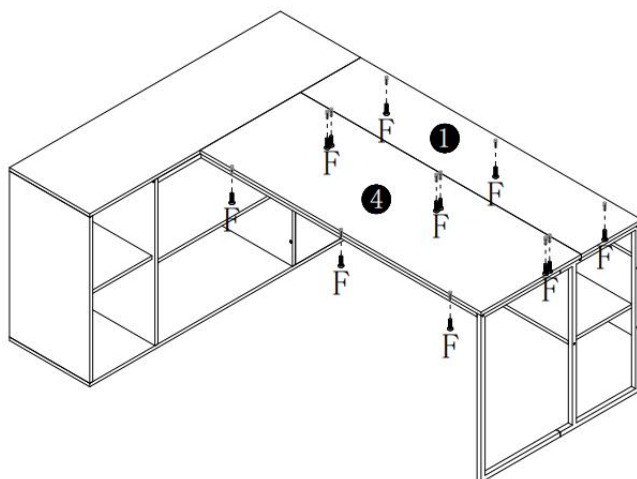

20

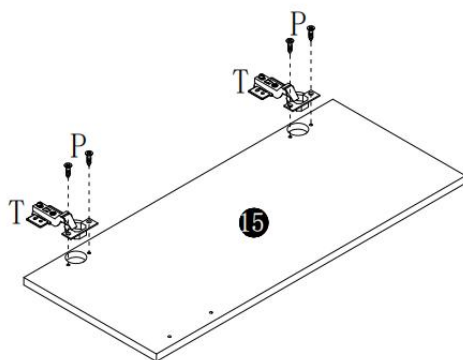

ASSEMBLY STEP

21

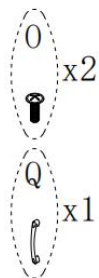
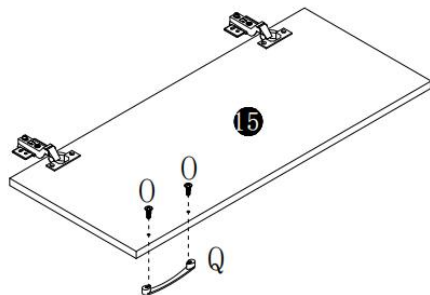

22

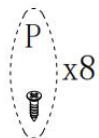
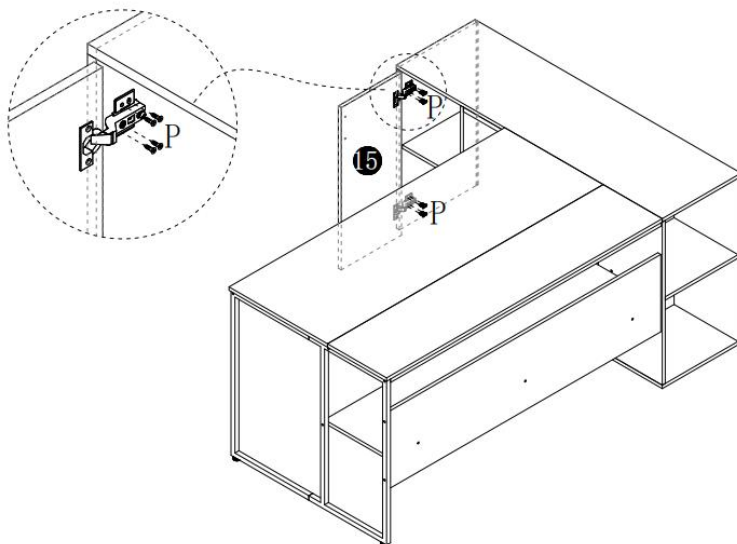

ASSEMBLY STEP

23

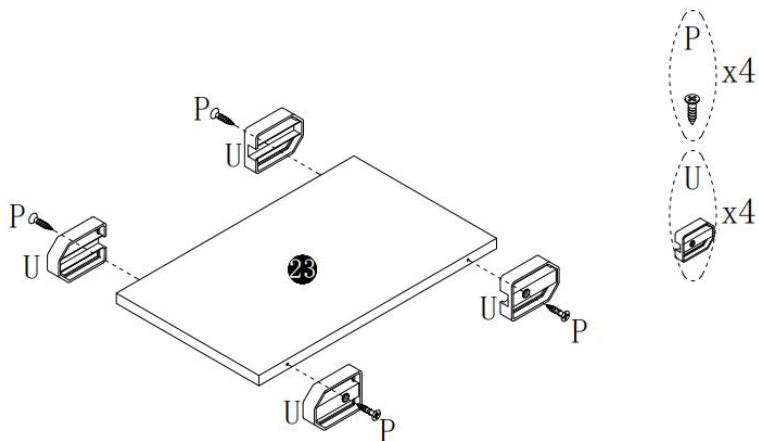

24

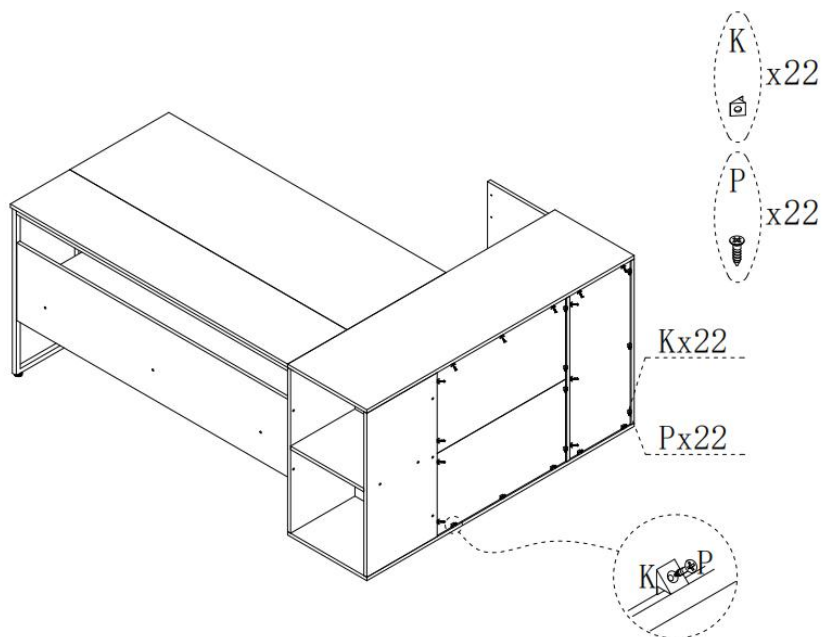

ASSEMBLY STEP

25

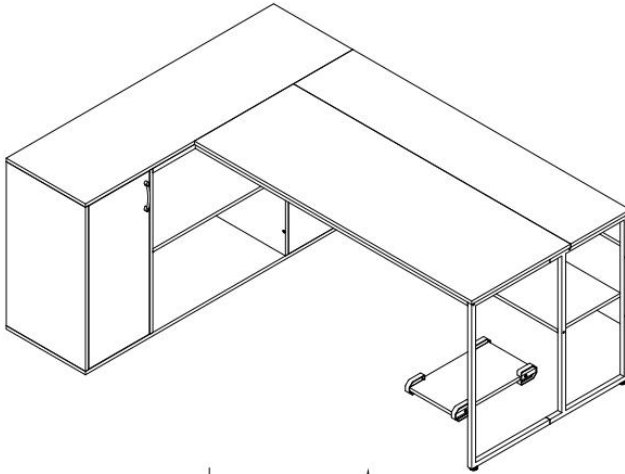

↓
OR
↑

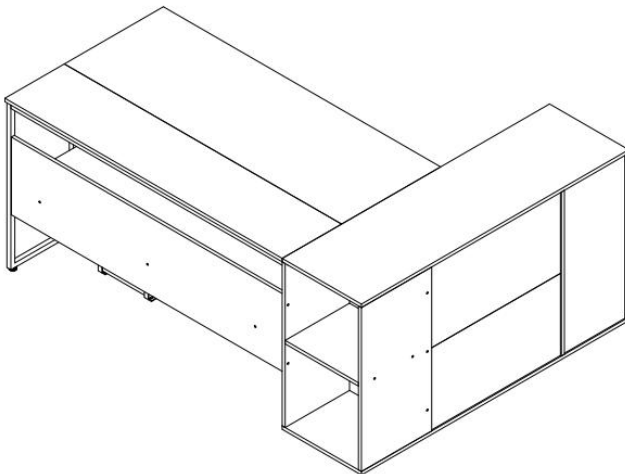

PRODUCT PARAMETER

Model	C25024 3 D-01
Veilig laadgewicht	350 pond
Productafmetingen (D*B*H)	1 8 00* 80 0* 75 0mm

* Productspecificaties, zoals het uiterlijk en het ontwerp, kunnen zonder voorafgaande kennisgeving worden gewijzigd.

Fabrikant: Shanghaimuxinmuyeyouxiangongsi

Adres: Shuangchenglu 803nong11hao1602A-1609shi, baoshanqu, shanghai 200000 CN.

Geïmporteerd naar AUS: SIHAO PTY LTD. 1 ROKEVA STREETEASTWOOD NSW 2122 Australië

Geïmporteerd naar de VS: Sanven Technology Ltd. Suite 250, 9166 Anaheim Place, Rancho Cucamonga, CA 91730

EC	REP
-----------	------------

E-CrossStu GmbH
Mainzer Landstr.69, 60329 Frankfurt am Main.

UK	REP
-----------	------------

YH CONSULTING LIMITED.
C/O YH Consulting Limited Office 147, Centurion House, London Road, Staines-upon-Thames, Surrey, TW18 4AX



VEVOR

Affordable. Reliable. Home Improvement.

SKRIVBORD

MODELL: C250243D-01

VEVOR

Affordable. Reliable. Home Improvement.

EXECUTIVE DESK

MODELL: C25024 3 D-01

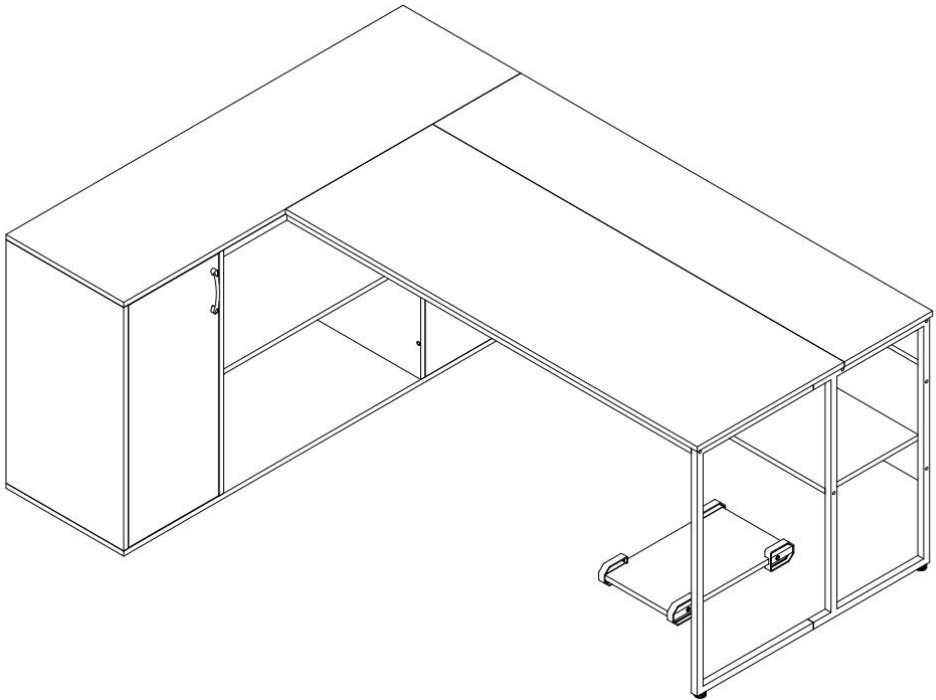

Detta är originalinstruktionerna, vänligen läs alla instruktioner noggrant innan du använder produkten. VEVOR förbehåller sig en tydlig tolkning av vår användarmanual. Produktens utseende ska vara beroende av den produkt du mottagit. Vi ber om ursäkt för att vi inte kommer att informera dig igen om det finns några teknik- eller programuppdateringar för vår produkt.

SAFETY INSTRUCTIONS

INTRODUKTION

Tack för att du köpt våra produkter. Vårt livslånga mål är att förse våra kunder med produkter och service av bästa kvalitet. Läs detta innan du använder produkten.

instruktionsmanual noggrant för att säkerställa korrekt användning. Förvara bruksanvisningen på en plats där användaren kan hitta den när som helst.

MONTERING FÖRSIKTIGHETSÅTGÄRDER

Det finns många komponenter och tillbehör i paketet. Varje en komponent och tillbehör är märkt med en bokstav eller siffra, kontrollera noggrant innan du använder någon av dem. Håll dem utom räckhåll för barn förhindra olyckor.

78. Montera endast enligt dessa instruktioner. Felaktig montering kan orsaka risker.
79. Använd ANSI-godkända skyddsglasögon och kraftiga arbetshandskar under monteringen.
80. Håll samlingsområdet rent och väl upplyst.
81. Håll åskådare borta från området under monteringen.
82. Montera inte om du är trött eller påverkad av alkohol, droger eller mediciner.
83. Produktens egenskaper gäller endast korrekt och fullständigt monterade produkter.
84. Installera produkten på ett rent och mjukt underlag (t.ex. en matta eller kartong) för att undvika repor eller skador på ytan på produkt .
85. Om möjligt kan du använda elverktyg för att underlätta monteringen.
86. Produktens huvudkomponenter är relativt tunga. Vänligen betala uppmärksamhet på säkerheten under installationen .
87. Produkten är inte stabil under installationen. Flytta den inte slumpmässigt. innan den är helt installerad .

88. För ytterligare information om de delar som listas i följande sidor, vänligen se monterings schemat i denna manual. Packa upp och separera alla delar på en ren arbetsyta.

***VÄNLIGEN FÖLJ INSTALLATIONSSTEGEN I HANDBOKEN FÖR ATT UNDVIK ONÖDIGA FÖRLUSTER ORSAKAD AV FELAKTIG INSTALLATION.**

ANVÄND FÖRSIKTIGHETSÅTGÄRDER







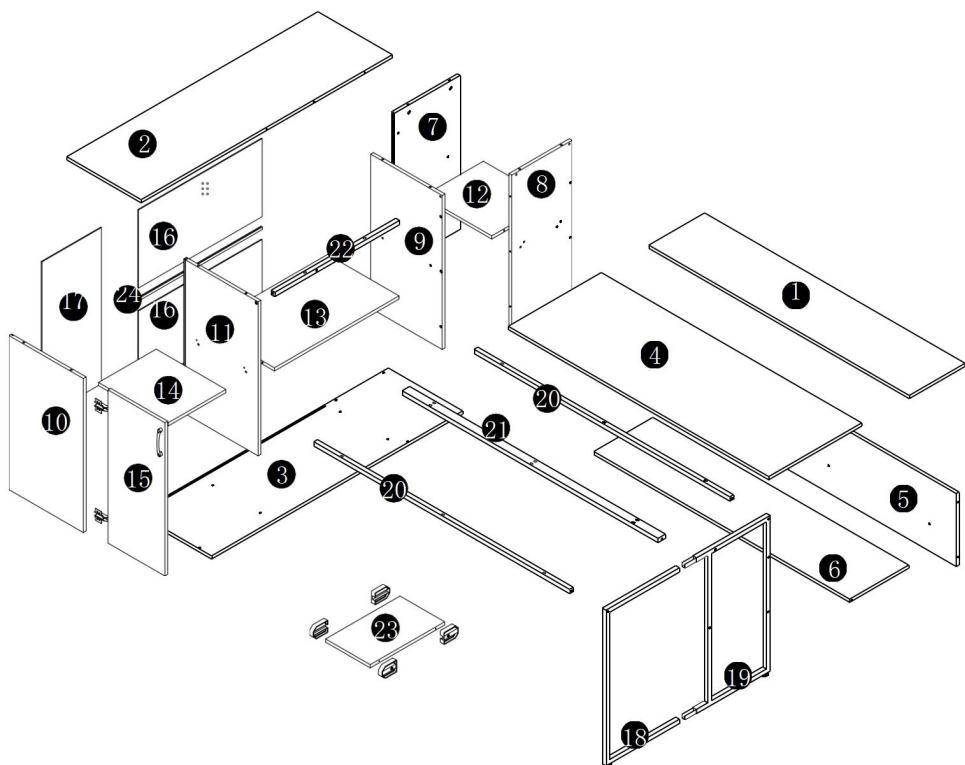







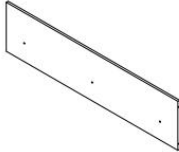

- 29) Överskrid inte angivna viktkapacitet.
- 30) Använd endast på en plan, jämn, hård och slät yta som säkert kan bära ett fullt lastat chefsskrivbord.
- 31) Använd endast som avsett.
- 32) Kontrollera före varje användning; använd inte om delar är lösa eller skadade.

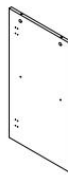
SPARA DENNA HANDBOK



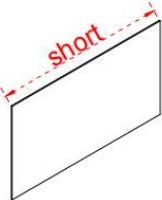
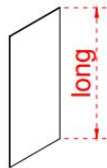
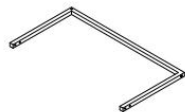
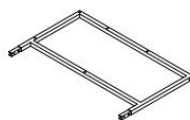

EXPLODED VIEW







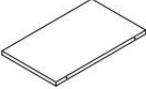









PARTS LIST

 <p>1 1pc</p>	 <p>2 1pc</p>	 <p>3 1pc</p>	 <p>4 1pc</p>
 <p>5 1pc</p>	 <p>6 1pc</p>	 <p>7 1pc</p>	 <p>8 1pc</p>
 <p>9 1pc</p>	 <p>10 1pc</p>	 <p>11 1pc</p>	 <p>12 1pc</p>
 <p>13 1pc</p>	 <p>14 1pc</p>	 <p>15 1pc</p>	 <p>16 2pcs</p>
 <p>17 1pc</p>	 <p>18 1pc</p>	 <p>19 1pc</p>	 <p>20 2pcs</p>

PARTS LIST

			
21 1pc	22 1pc	23 1pc	24 1pc

 M6X40MM A 14pcs	 M7X50MM B 34pcs	 C 14pcs	 M6X30MM F 14pcs	 M6X40MM H 8pcs
 K 22pcs	 M6X10MM N 4pcs	 M4X18MM O 2pcs	 ST3. 5X12MM P 38pcs	 Q 1pc
 DWX15MM T 2pcs	 U 4pcs	 X 3pcs	 M8X14MM Y 2pcs	 1pc
				

ASSEMBLY STEP

Installation av kammar och stift

Skruva fast stiftet i hålet. För att justera kammarna korrekt, se till att pilen på kammens öppnas mot hålet på stiftet som den låser. Lås kammens genom att vrida kamhuvudet med en skruvmejsel tills den är åtdragen. Använd inte en elektrisk skruvmejsel för att montera. enhet.

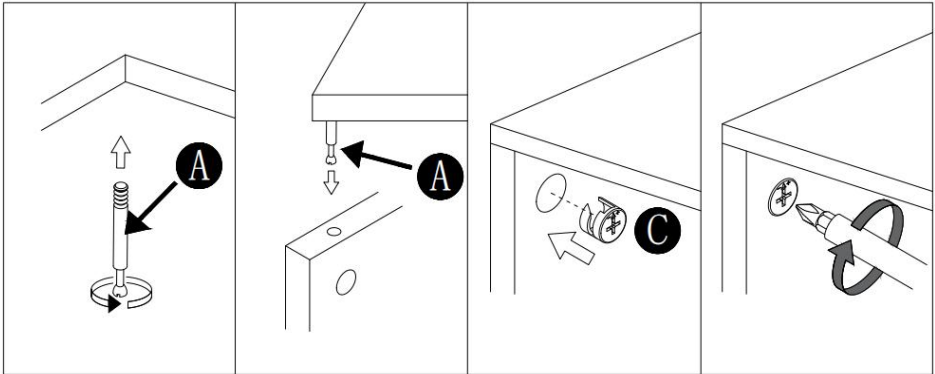

Läs varje steg noggrant innan du börjar. Det är mycket viktigt att varje steg i instruktionerna utförs i rätt ordning. Om dessa steg inte följs i rätt ordning kan monteringsproblem uppstå.
inträffa.

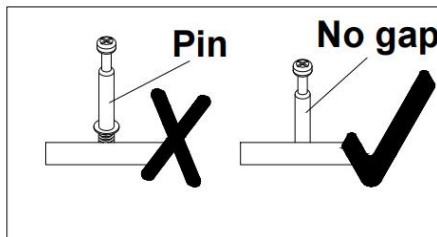

ASSEMBLY STEP

1

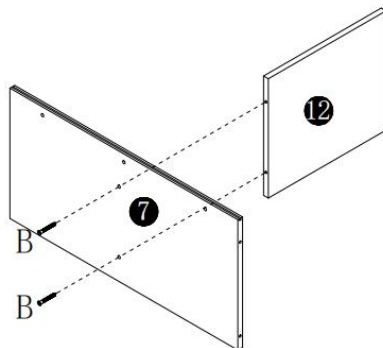
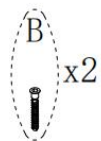

2

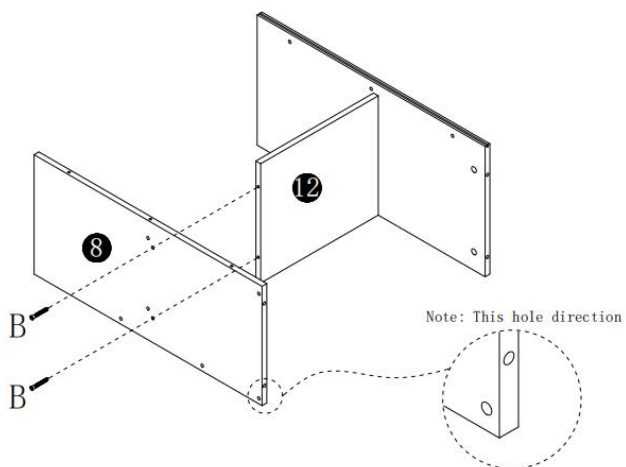
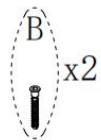

ASSEMBLY STEP

3

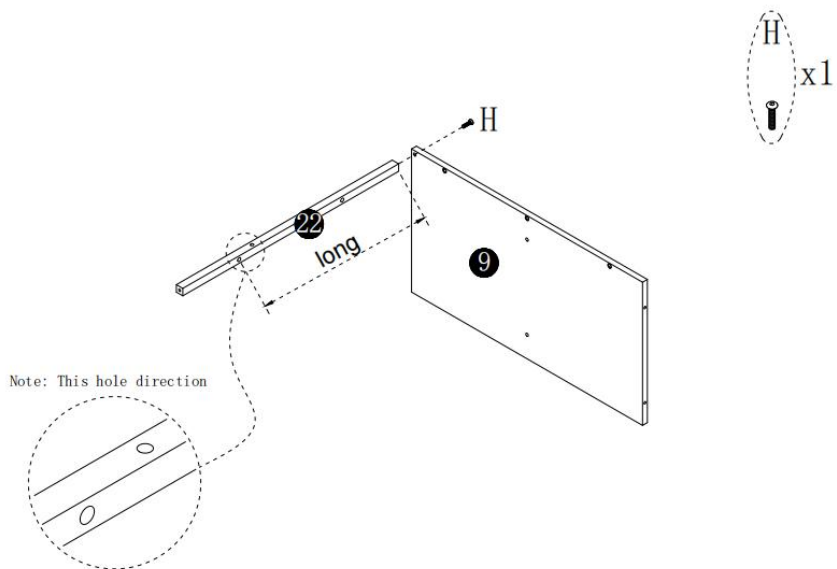

4

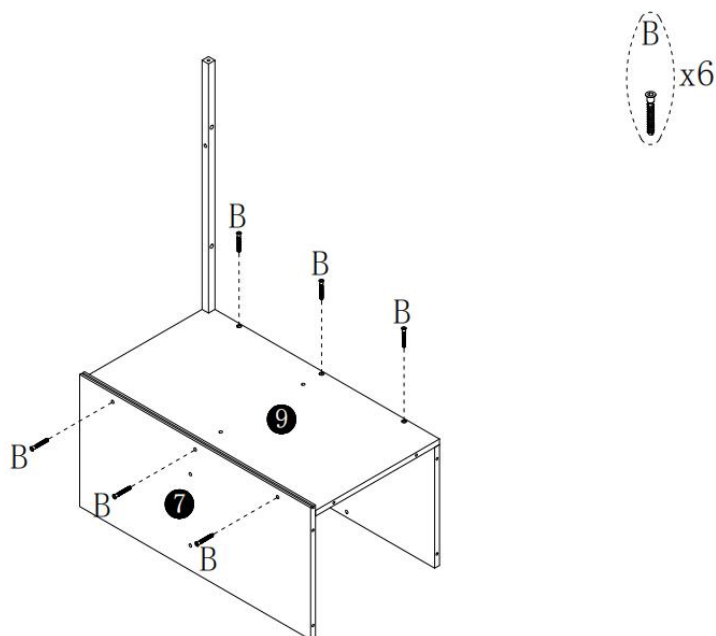

ASSEMBLY STEP

5

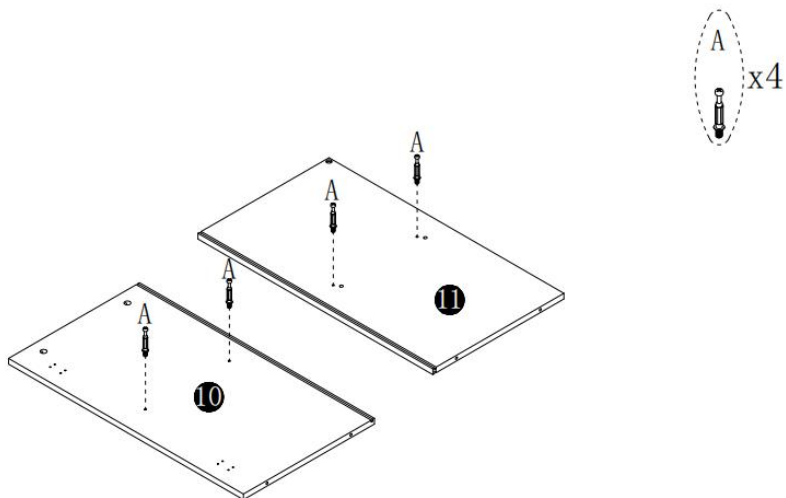

6

Note: This hole direction

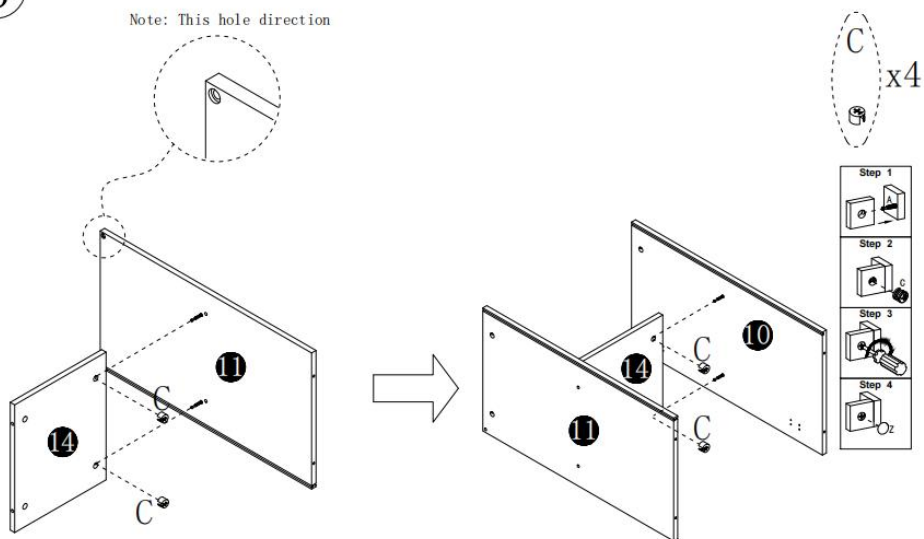

ASSEMBLY STEP

7

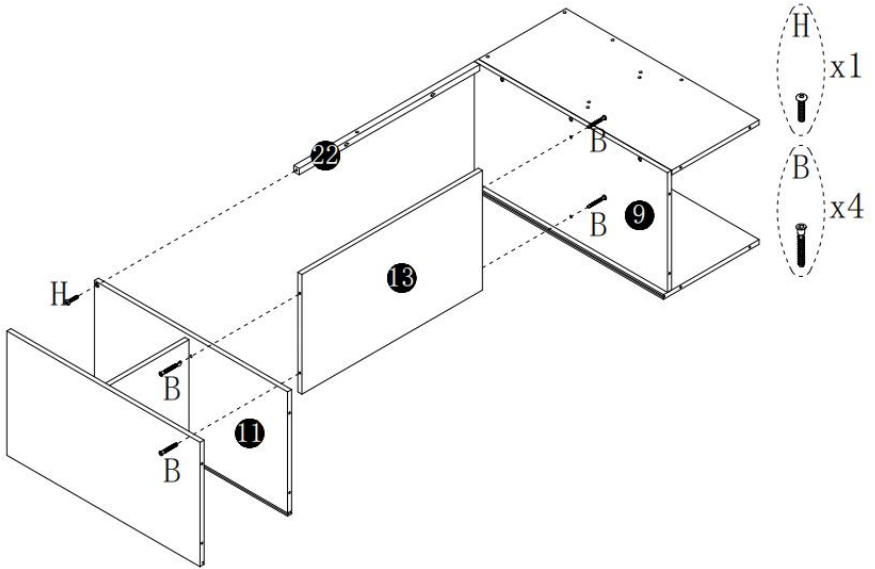

8

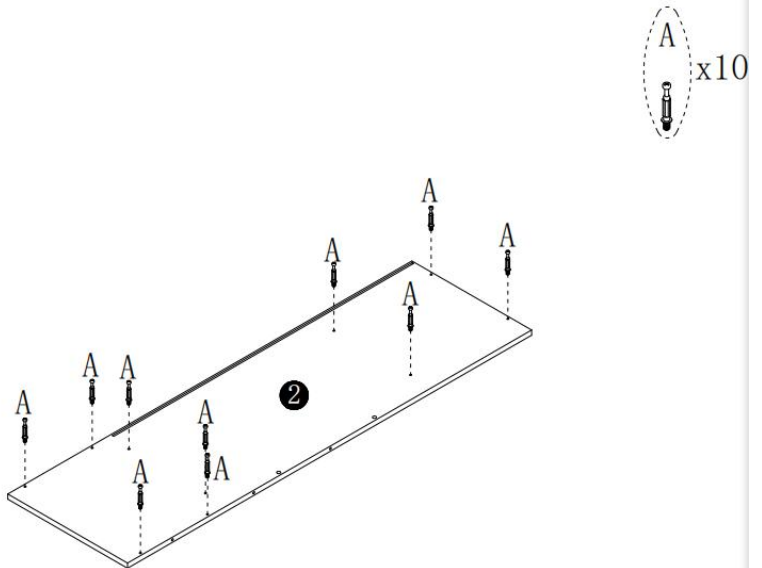

ASSEMBLY STEP

9

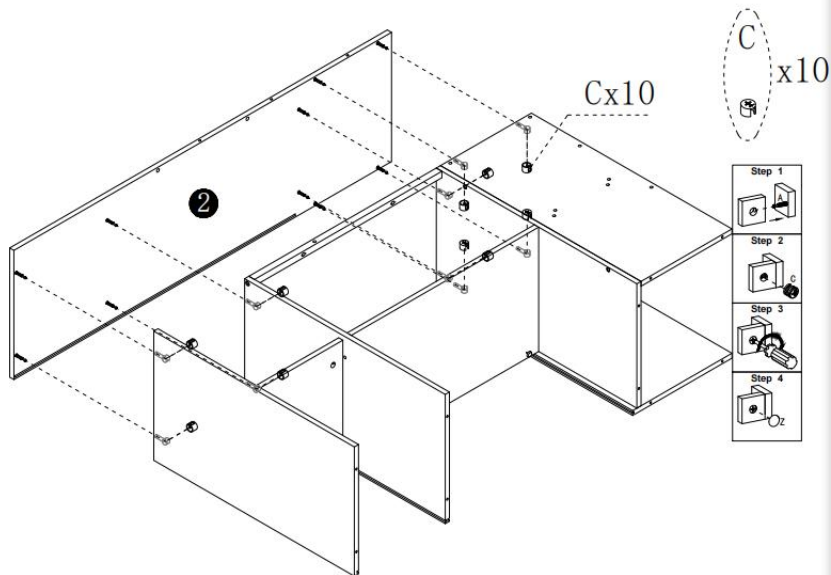

10

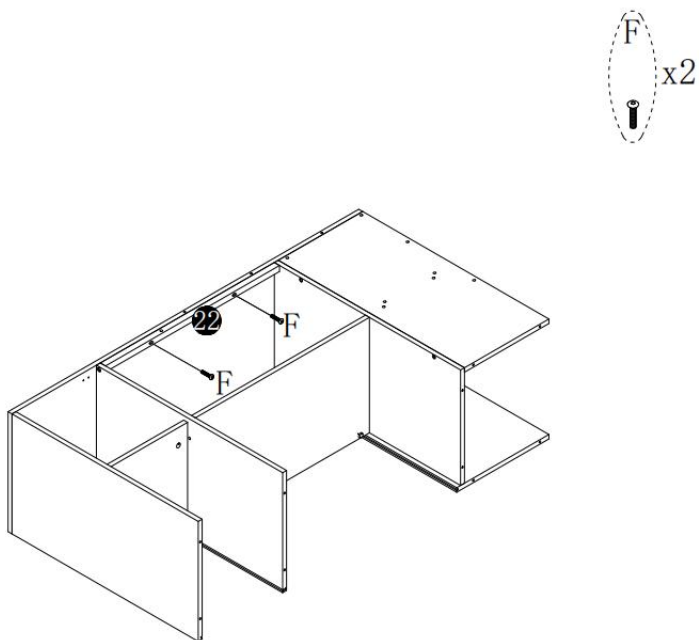

ASSEMBLY STEP

11

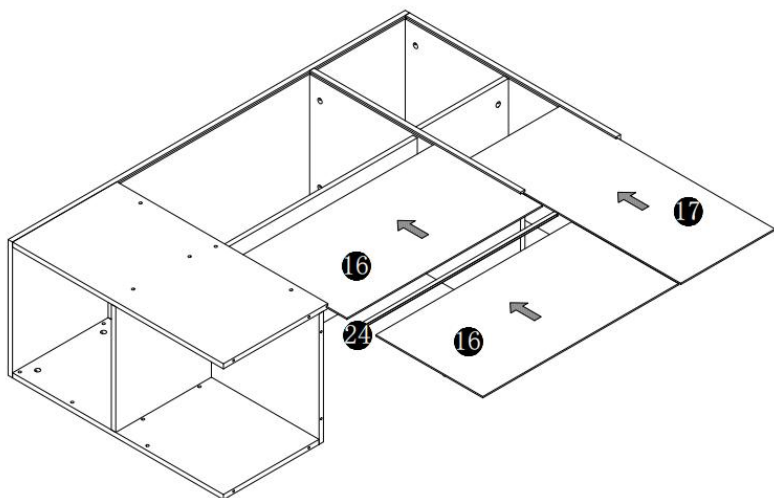

12

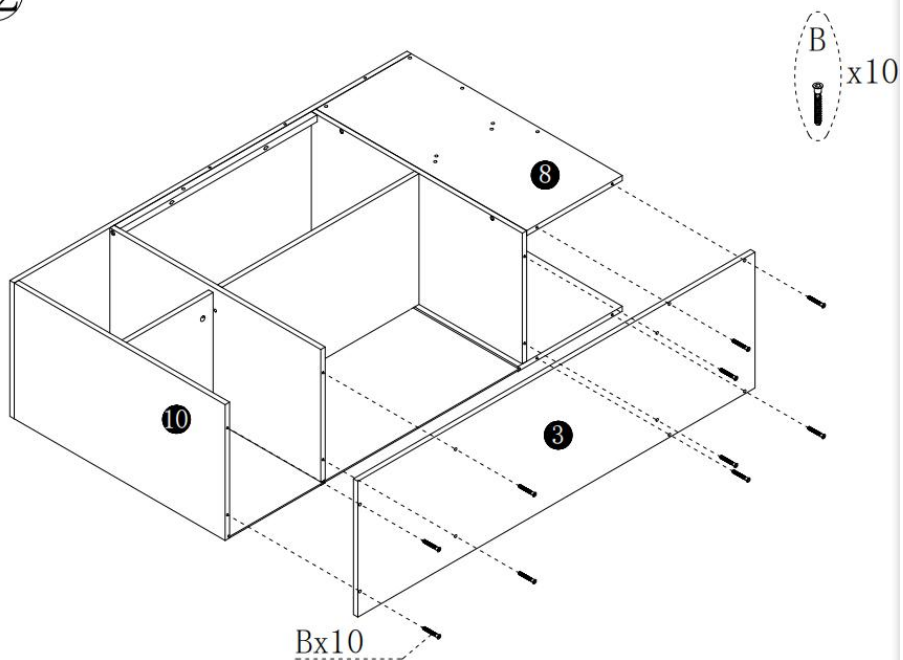

ASSEMBLY STEP

13

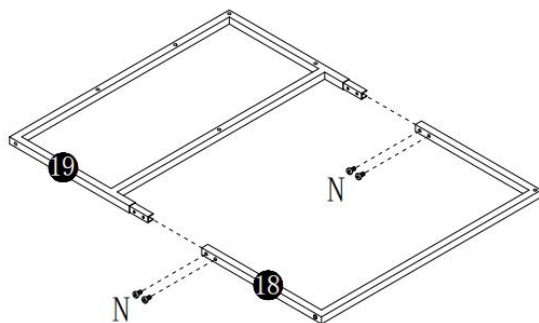
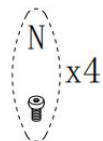

14

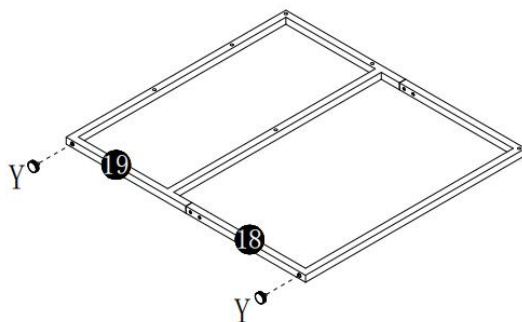
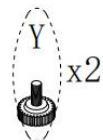

ASSEMBLY STEP

15

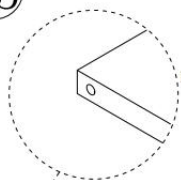

Note: This hole direction

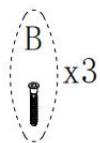
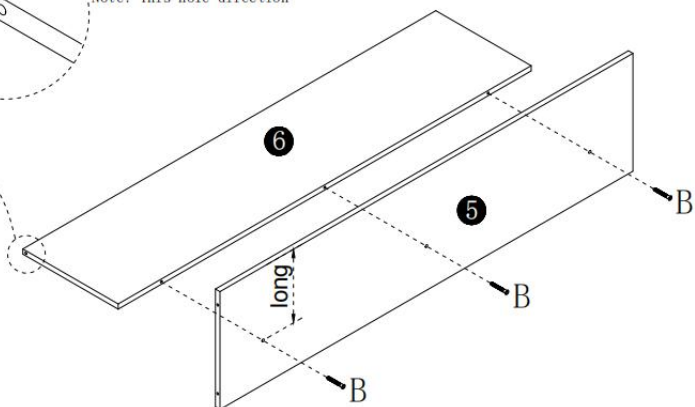

16

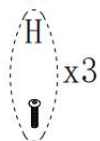
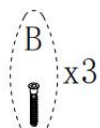
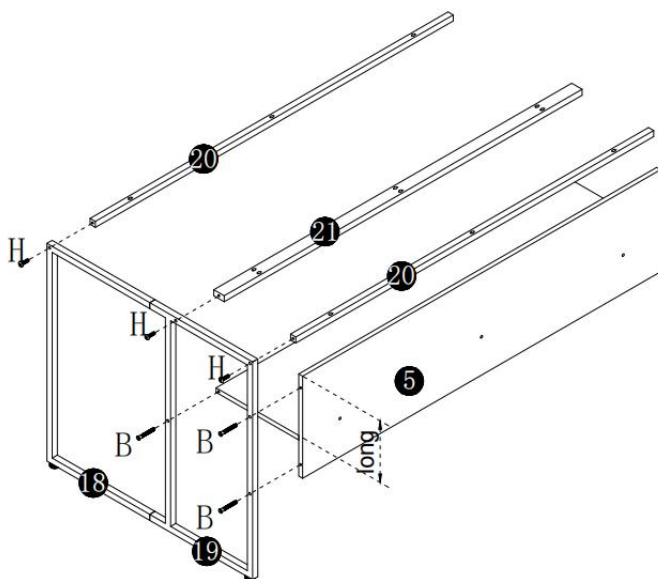

ASSEMBLY STEP

17

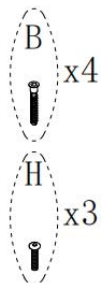
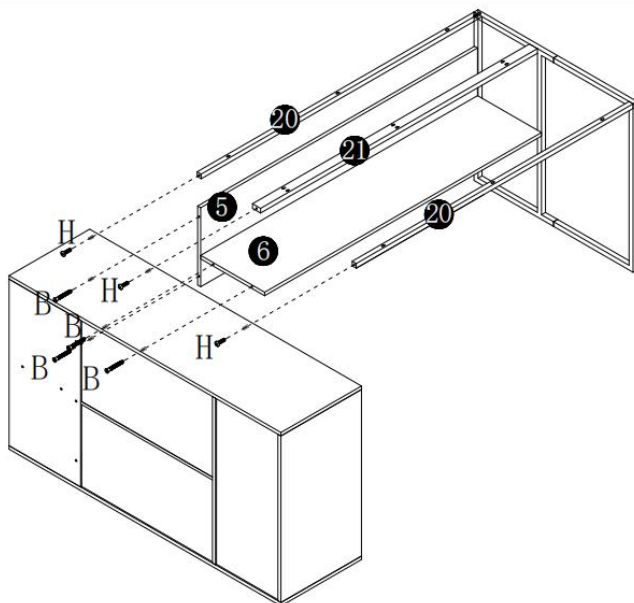

18

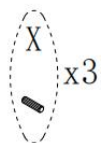
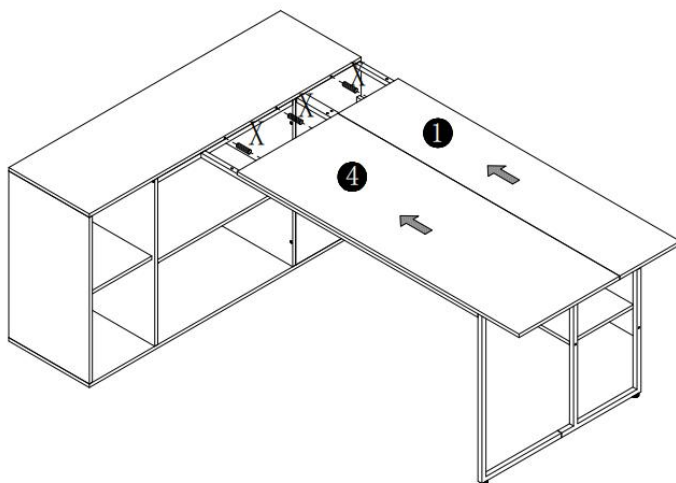

ASSEMBLY STEP

19

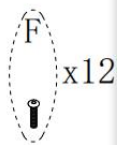
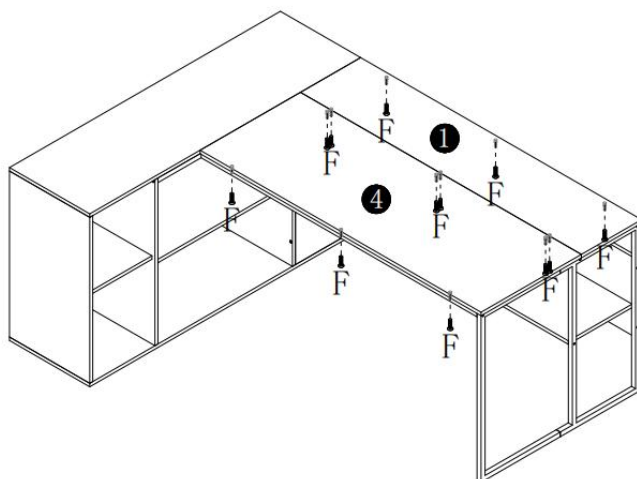

20

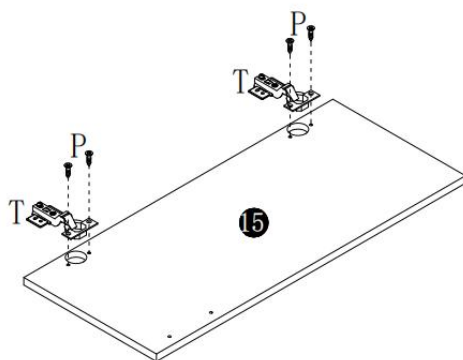

ASSEMBLY STEP

21

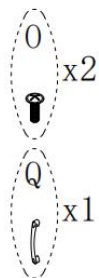
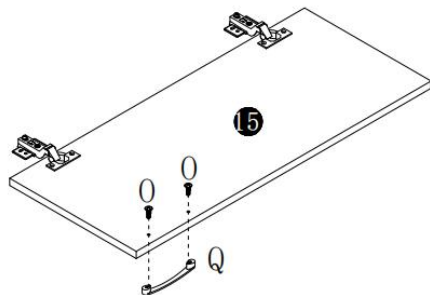

22

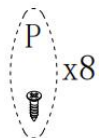
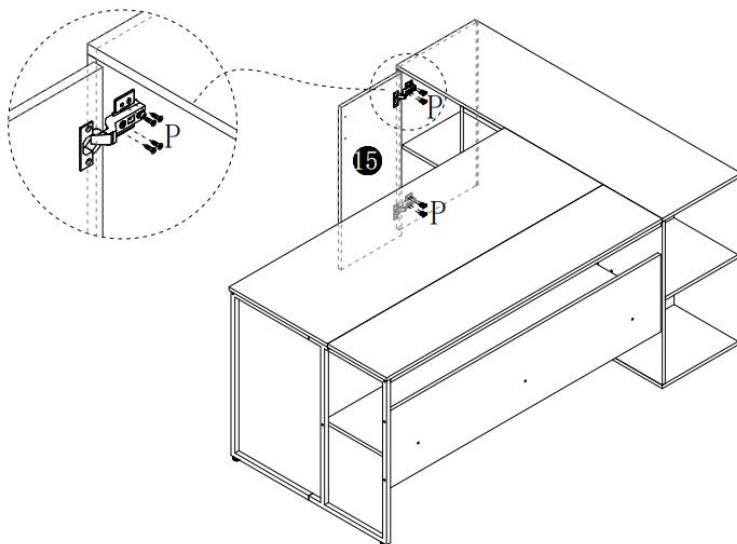

ASSEMBLY STEP

23

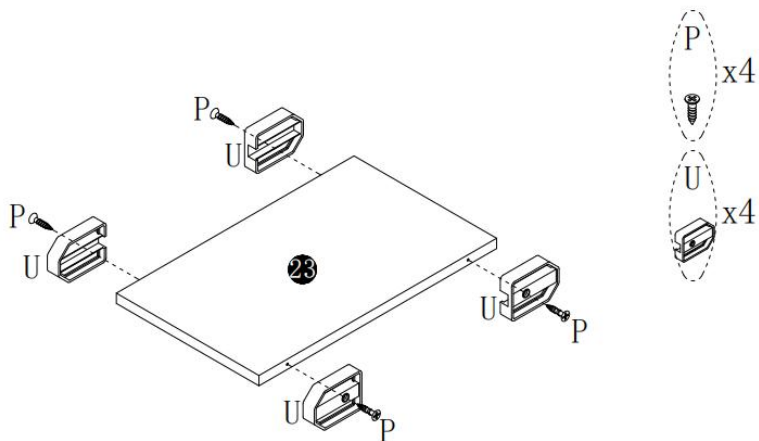

24

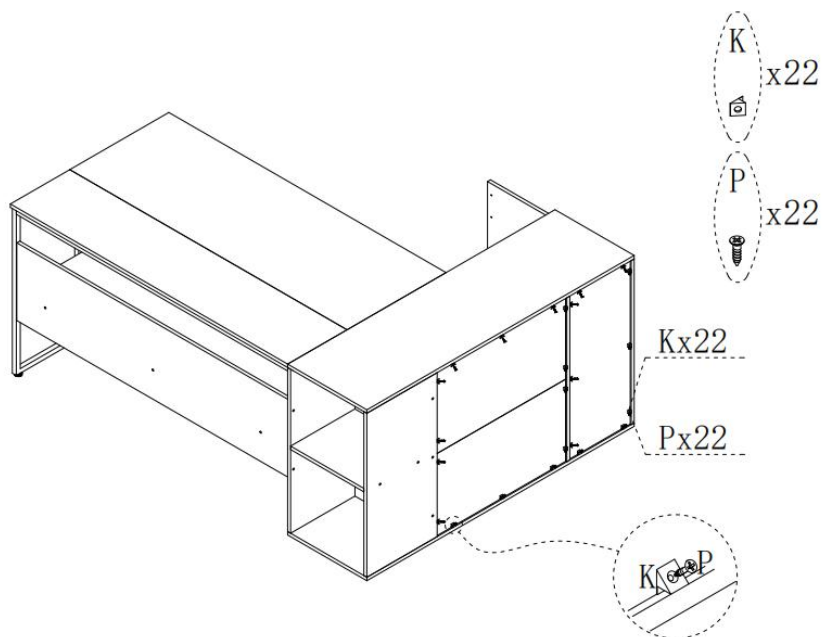

ASSEMBLY STEP

25

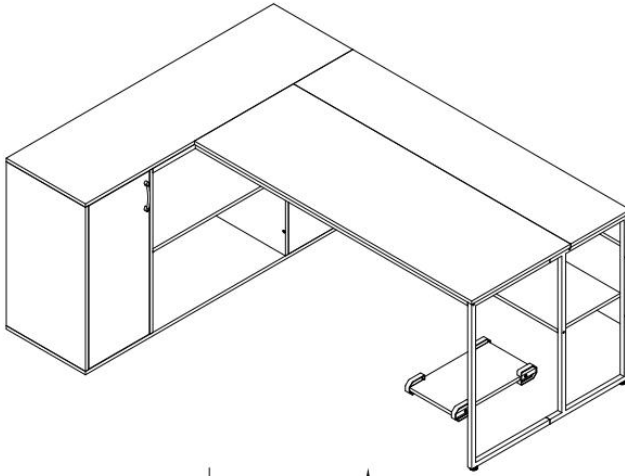

↓
OR
↑

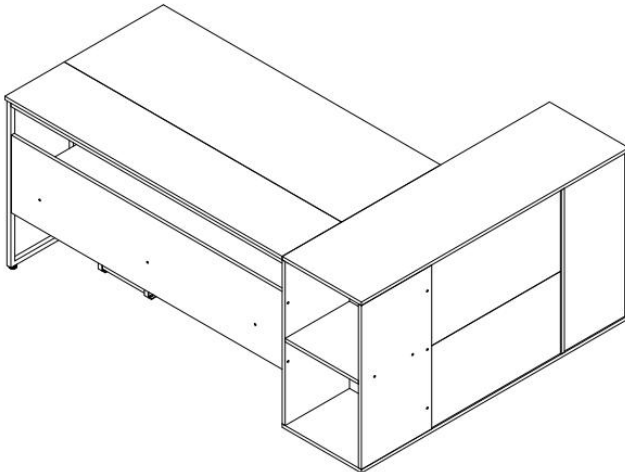

PRODUCT PARAMETER

Modell	C25024 3 D-01
Säker lastvikt	350 pund
Produktstorlek (D*B*H)	1800 * 800 * 750mm

* Produkters specifikationer, utseende och design kan komma att ändras utan föregående meddelande.

Tillverkare: Shanghaimuxinmuyeyouxiangongsi

Address: Shuangchenglu 803nong11hao1602A-1609shi, baoshanqu, shanghai 200000 CN.

Importerad till Australien: SIHAO PTY LTD. 1 ROKEVA
STREETEASTWOOD NSW 2122 Australien

Importerad till USA: Sanven Technology Ltd. Suite 250, 9166 Anaheim
Place, Rancho Cucamonga, CA 91730

EC	REP
-----------	------------

E-CrossStu GmbH
Mainzer Landstr.69, 60329 Frankfurt am Main.

UK	REP
-----------	------------

YH CONSULTING LIMITED.
C/O YH Consulting Limited Office 147, Centurion
House, London Road, Staines-upon-Thames, Surrey,
TW18 4AX

