

VEVOR[®]

TOUGH TOOLS, HALF PRICE

Technical Support and E-Warranty Certificate

www.vevor.com/support

LOCKOUT TAGOUT KIT

USER MANUAL

We continue to be committed to provide you tools with competitive price.

"Save Half", "Half Price" or any other similar expressions used by us only represents an estimate of savings you might benefit from buying certain tools with us compared to the major top brands and does not necessarily mean to cover all categories of tools offered by us. You are kindly reminded to verify carefully when you are placing an order with us if you are actually saving half in comparison with the top major brands.

VEVOR[®]

TOUGH TOOLS, HALF PRICE

LOCKOUT TAGOUT KIT

MODEL: BY002



NEED HELP? CONTACT US!

Have product questions? Need technical support? Please feel free to contact us:

Technical Support and E-Warranty Certificate
www.vevor.com/support

This is the original instruction, please read all manual instructions carefully before operating. VEVOR reserves a clear interpretation of our user manual. The appearance of the product shall be subject to the product you received. Please forgive us that we won't inform you again if there are any technology or software updates on our product.

SAFETY INSTRUCTIONS

WARNING:

Read this material before using this product. Failure to do so can result in serious injury.

Assembly precautions

1. Assemble only according to these instructions. Improper assembly can create hazards.
2. Wear safety goggles and duty work gloves during assembly.
3. Keep the assembly area clean and well-lit.
4. Keep bystanders out of the area during assembly.
5. Do not assemble when tired or when under the influence of alcohol, drugs or medication.
6. The product capabilities apply to properly and completely assembled products only.
7. Assemble on a flat, level, hard and smooth surface capable of safely supporting the Lockout Tagout Kit.
8. For additional information regarding the parts listed in the following pages, please refer to the Assembly Diagram of this manual. Unwrap and separate all parts in a clean work area.

Use precautions

1. **DO NOT SIT OR STAND ON THIS ITEM.**
2. This product is not a toy. Do not allow children to play with or near this item.
3. Do not exceed capacities.
4. Use only on a flat, level, hard and smooth surface capable of safely supporting a fully loaded Lockout Tagout Kit.
5. Use as intended only.
6. Inspect before every use; do not use if parts are loose or damaged.

SAVE THIS MANUAL

PRODUCT PARAMETER

Model	BY002
Number Of Sets	42
Product Size	495*300*300 mm

PARTS LIST

Name	Code	qty
Storage Case	Z30	1
Safety padlock	G01 (2keys per lock)	4
Lockout Tagout	P01	16
PA coated steel hasp	K01	2
	K02	2
Nylon coated steel hasp	K42	2
Miniature circuit breaker lockout	D01	2
	D02	2
Clamp-on breaker lockout	D12	2
Multi-function miniature breaker lockout	D14	2

Medium circuit breaker lockout	D17	1
	D18	1
Electrical plug lockout	D41	1
	D42	1
Adjustable ball valve lockout	F01	1
Adjustable gate valve lockout	F16	1
Adjustable cable lockout	L11	1
Cable tie	/	16

INSTRUCTIONS

STORAGE CASE



Model:: Z30

Size: 400*240*240 mm

PA COATED STEEL HASP

- Made from Engineering plastic nylon PA injection molding, galvanized rustproof surface.
- Lock hole diameter: 10.5mm(2/5").
- Lock shackle diameter: 25mm(1")&38mm(1.5").
- Such as custom made stainless steel material, the model behind plus "S".

Part Code	Description
BD-K01	Lock shackle 25mm(1")
BD-K02	Lock shackle 38mm (1.5")

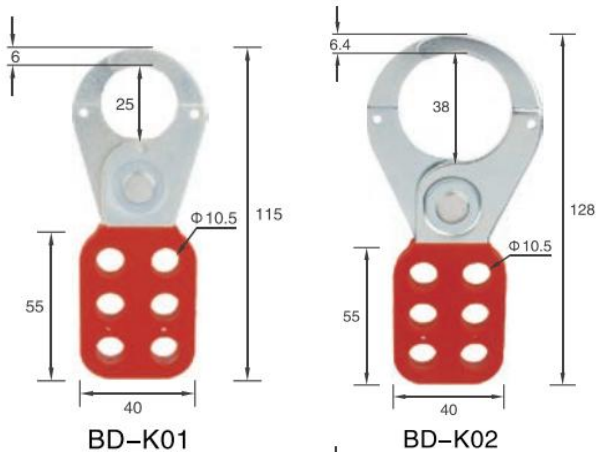

NYLON LOCKOUT HASP

- a. High fire-resistant aluminum alloy.
- b. Apply to places where need electric power isolation and lock and has high requires about corrosive and explosion-proof,
Opening: push up and down.

Part Code	Description
BD-K41	Allow to 6 padlocks
BD-K42	Allow to 6 padlocks

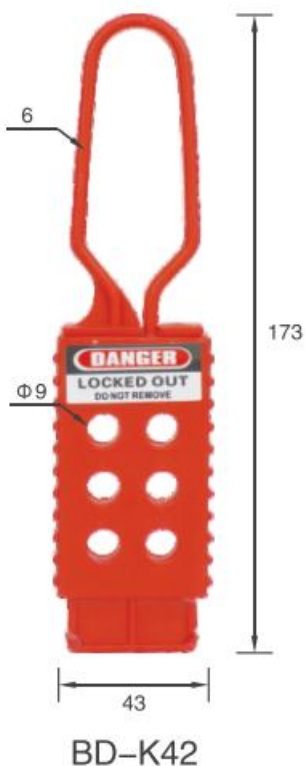

SAFETY PADLOCK

Shackle Type:



Steel shackle Nylon shackle Short/ultra short shackle
 Long steel shackle Long nylon shackle Cable shackle

With rewritable safety warning signs
 (can customize luminous PVC material,
 language, logo, department and so on)



Can print key number



Suitable for use in closed space, such as: chemical, Military, oil extraction and power industry

Normal color: ●RED, ●YLW, ●BLU, ●GRN, ●ORG, ●PRP, ●BLK, WHT,

Other colors can be custom made.
 Durable non-conductive PA lock body,
 withstand temperature from -20°C to 150°C, resistance of UV rays.



Copper cylinder Zinc alloy cylinder

- Normal version, old version padlock (copper/ zinc alloy lock cylinder)
 Key retention-the key cannot be pulled out in the open state, ensuring that the padlock will not be left behind
- New padlock (zinc alloy lock cylinder)
Self-rebound self-reset -lock shackle with self-elastic function
 When the padlock is opened, the key is automatically reset to the initial position and the key can be removed.



(Unit: mm)

LOCKOUT TAGOUT

- a. Lockout tagout can be used to make a holistic control of the equipment to protect workers from accident and equipment from damage.
- b. Use with padlock to remind that the device has been locked and can not be operated. It can only be opened by the one who lock it. It enables people to know who lock it and so that they know it is danger to operate the device.
- c. On the tag, you can see "Danger/Do not operate/caution" etc security warning language and also "Name/department/Date" etc blank for you to fill in.
- d. Offer language customization.



MINIATURE CIRCUIT BREAKER LOCKOUT

- e. Made from engineering plastic strengthened nylon PA.
- f. Fit most existing types of European and Asia Circuit Breaker.
- g. Easily installed with the aid a push button or rotate roller.
- h. Available for single and multi-pole circuit breaker
- i. Recommended to use in combination with a padlock for added safety.
- j. Can use padlocks with a shackle diameter up to 7mm.

Part Code	Description
BD-D01	POS (Pin Out Standard), hole spacing $\leq 12\text{mm}$
BD-D02	PIS (Pin In Standard), hole spacing $\leq 12\text{mm}$

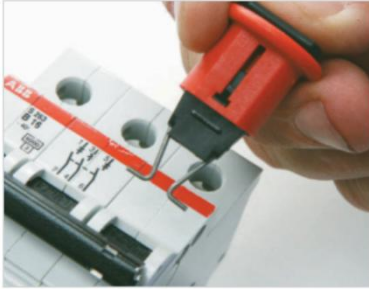

BD-D01(Pin Out Standard)

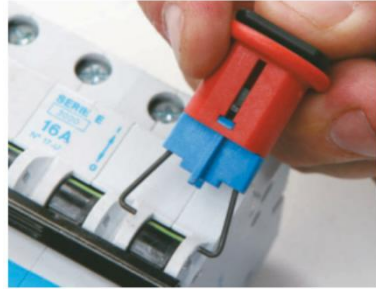

BD-D02(Pin In Standard)

CLAMP-ON BREAKER LOCKOUT

- Made from rugged polypropylene PP and impact modified PA.
- Use thumbscrew to clamp lockout securely onto switch tongue, then pull cover and lock in place to prevent clamp from being loosened.
- New blade design provides tighter grip with less torque on thumb screw.
- Detachable cleats expand the range of applicable breakers.
- The lockouts can take padlocks with a shackle diameter up to 7mm.

Part Code	Description
BD-D12	Can lock handle width $\leq 42\text{mm}$



Lockable range: 13mm \times 38mm

BD-D12

MULTI-FUNCTION MINIATURE BREAKER LOCKOUT

- a. Made from engineering plastic strengthened nylon PA and chrome plated brass screw.
- b. With locking screws, can be locked without tools.
- c. Widely used: applicable to all kinds of small and medium sized MCCB, and any miniature circuit breaker.
- d. Can be customized stainless steel brand.

Part Code	Description
BD-D14	Allow 1 padlock with shackle diameter $\leq 7\text{mm}$



MEDIUM CIRCUIT BREAKER LOCKOUT

- a. Made from Die-cast aluminum alloy & Nylon & ABS, The surface sprays metal.
- b. With locking screws, can be locked without tools.
- c. Widely used,

BD-D17, suitable for small and medium sized circuit breaker (handle < 12mm)

BD-D18, suitable for small and medium sized circuit breaker (handle < 16mm)

Part Code	Description
BD-D17	$7.5\text{mm} \leq a \leq 12\text{mm}$
BD-D18	$8\text{mm} \leq a \leq 16\text{mm}$



BD-D17



BD-D18

ELECTRICAL PLUG LOCKOUT

- a. Made from rugged polypropylene.
- b. Double open and hexagon lockout design, suitable for all kinds of industrial plugs.
- c. Accommodates 2 to 4 pieces padlocks with shackle diameter less than 7mm to lock it at the same time.

Part Code	Description
BD-D41	51mm(height)*51mm(thickness)*89mm(width), for cable diameter 13mm
BD-D42	65mm(height)*65mm(thickness)*118mm(width), for cable diameter 20mm

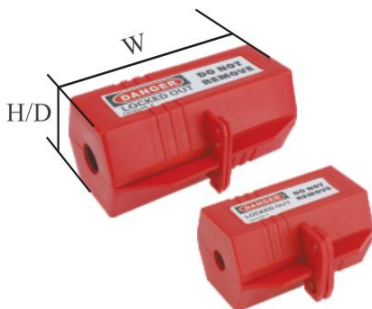

ADJUSTABLE BALLVALVE LOCKOUT

- a. Made from polypropylene PP.
- b. Applied Sizes:
BD-F01 locks out pipes from 13mm(1/2")to 64mm(2 1/2")in diameterb)
- c. Padlock locked shackle max diameter:9mm
- d. d.Color:red,other colors need to be customized.

Part Code	Description
BD-F01	Suitable for 13mm(1/2")to 64mm(2 1/2")pipes



ADJUSTABLE GATE VALVE LOCKOUT

- a. Made from polypropylene PP.
- b. Lock range can be adjusted.Lock the hand wheel diameter 25mm-165mm(1"-6.5")valve.
- c. Locked by one padlock,locked shackle diameter max 7mm.
- d. Color:red,other colors need to be customized.Tagout is available.

Part Code	Description
BD-F16	Valve rod diameter 25mm-165mm(1"-6.5")



ADJUSTABLE CABLE LOCKOUT

- e. Made from impact resistant engineering plastic PC, other colors can be customized.
- f. Used 1.8 meter cable, the outer layer of cable is made from anti-UV PVC(diameter 6mm), the cable can be customized with different length and colors.
- g. Withstand extra temperatures of -46°C to 149°C .
- h. Locked with 4 padlocks, lock shackle diameter is less than 7mm.

Part Code	Description
BD-L11-1	Cable specification: 4mm*1.8m
BD-L11-2	Cable specification: 6mm*1.8m



BD-L11

Manufacturer: Shanghaimuxinmuyeyouxiangongsi

Address: Baoshanqu Shuangchenglu 803long 11hao 1602A-1609shi
Shanghai

Imported to AUS: SIHAO PTY LTD, 1 ROKEVA STREETEASTWOOD
NSW 2122 Australia

Imported to USA: Sanven Technology Ltd.

Suite 250,9166 Anaheim Place, Rancho Cucamonga, CA 91730



SHUNSHUN GmbH

Römeräcker 9 Z2021,76351

Linkenheim-Hochstetten, Germany

euvertreter@gmail.com

+49 1727041930



Pooledas Group Ltd

Unit 5 Albert Edward House, The

Pavilions Preston, United Kingdom

pooledas123@gmail.com

Tel: 01772418127

Made In China

VEVOR[®]

TOUGH TOOLS, HALF PRICE

Technical Support and E-Warranty Certificate

www.vevor.com/support

VEVOR[®]

TOUGH TOOLS, HALF PRICE

Techniczny Wsparcie i certyfikat e-gwarancji

www.vevor.com/support

ZESTAW DO BLOKOWANIA I ETYKIETOWANIA INSTRUKCJA obsługi

We continue to be committed to provide you tools with competitive price.

"Save Half", "Half Price" or any other similar expressions used by us only represents an estimate of savings you might benefit from buying certain tools with us compared to the major top brands and does not necessarily mean to cover all categories of tools offered by us. You are kindly reminded to verify carefully when you are placing an order with us if you are actually saving half in comparison with the top major brands.

VEVOR®

TOUGH TOOLS, HALF PRICE

LOCKOUT TAGOUT KIT

MODEL: BY00 2



NEED HELP? CONTACT US!

Have product questions? Need technical support? Please feel free to contact us:

Technical Support and E-Warranty Certificate
www.vevor.com/support

This is the original instruction, please read all manual instructions carefully before operating. VEVOR reserves a clear interpretation of our user manual. The appearance of the product shall be subject to the product you received. Please forgive us that we won't inform you again if there are any technology or software updates on our product.

SAFETY INSTRUCTIONS

OSTRZEŻENIE:

Przeczytaj ten materiał przed użyciem tego produktu. Nieprzestrzeganie tego może spowodować poważne obrażenia.

Środki ostrożności podczas montażu

1. Montaż należy wykonywać wyłącznie zgodnie z niniejszą instrukcją. Nieprawidłowy montaż może stwarzać zagrożenia.
2. Podczas montażu należy nosić okulary ochronne i rękawice robocze.
3. Utrzymuj miejsce zgromadzenia w czystości i zapewnij dobre oświetlenie.
4. Nie dopuszczać osób postronnych na teren montażu podczas jego trwania.
5. Nie przychodź na spotkania, jeśli jesteś zmęczony lub pod wpływem alkoholu, narkotyków lub leków.
6. Możliwości produktu odnoszą się wyłącznie do produktów prawidłowo i kompletnie zmontowanych.
7. Zmontuj na płaskiej, równej, twardej i gładkiej powierzchni, która będzie w stanie bezpiecznie utrzymać zestaw Lockout Tagout .
8. Aby uzyskać dodatkowe informacje dotyczące części wymienionych na kolejnych stronach, zapoznaj się ze schematem montażu w tym podręczniku. Rozpakuj i oddziel wszystkie części w czystym miejscu pracy.

Stosuj środki ostrożności

1. NIE SIADAĆ ANI NIE STAWAĆ NA TYM PRZEDMIOCIE.
2. Ten produkt nie jest zabawką. Nie pozwalaj dzieciom bawić się tym przedmiotem ani przebywać w jego pobliżu.
3. Nie przekraczać dopuszczalnych limitów.
4. Stosować wyłącznie na płaskiej, równej, twardej i gładkiej powierzchni, która może bezpiecznie utrzymać w pełni załadowany zestaw Lockout Tagout .
5. Stosować wyłącznie zgodnie z przeznaczeniem.

6. Przed każdym użyciem należy przeprowadzić kontrolę. Nie należy używać produktu, jeśli jakieś części są luźne lub uszkodzone.

ZAPISZ TĘ INSTRUKCJĘ

PRODUCT PARAMETER

Model	BY00 2
Liczba zestawów	42
Rozmiar produktu	Wymiary: 495*300*300 mm

PARTS LIST

Nazwa	Kod	ilość
Etui do przechowywania	Z30	1
Kłódka bezpieczeństwa	G01 (2 klucze na zamek)	4
Blokada i etykietowanie	P01	16
Stalowa klamra powlekana PA	K01	2
	K02	2
Stalowa klamra powlekana nylonem	K42	2
Blokada wyłącznika nadprądowego	D01	2
	D02	2

Blokada wyłącznika zaciskowego	D12	2
Wielofunkcyjna blokada wyłącznika miniaturowego	D14	2
Blokada wyłącznika średniego	D17	1
	D18	1
Blokada wtyczki elektrycznej	D41	1
	D42	1
Regulowana blokada zaworu kulowego	F01	1
Regulowana blokada zaworu zasuwowego	F16	1
Regulowana blokada kabla	L11	1
Opaska zaciskowa	/	16

INSTRUCTIONS

SPRAWA STARAGE



Model:: Z30

Size: 400*240*240 mm

UCHWYT STALOWY POWLEKANY PA

- a. Wykonane z tworzywa sztucznego inżynierskiego nylonu PA formowanego wtryskowo, ocynkowane powierzchnia odporna na rdzę.
- b. Średnica otworu blokującego: 10,5 mm (2/5 ").
- c. Średnica pałaka zamka: 25 mm (1 ") i 38 mm (1,5 ").
- d. Taki jak niestandardowy materiał ze stali nierdzewnej, model z tyłu plus "S".

Part Code	Description
BD-K01	Lock shackle 25mm(1")
BD-K02	Lock shackle 38mm (1.5")

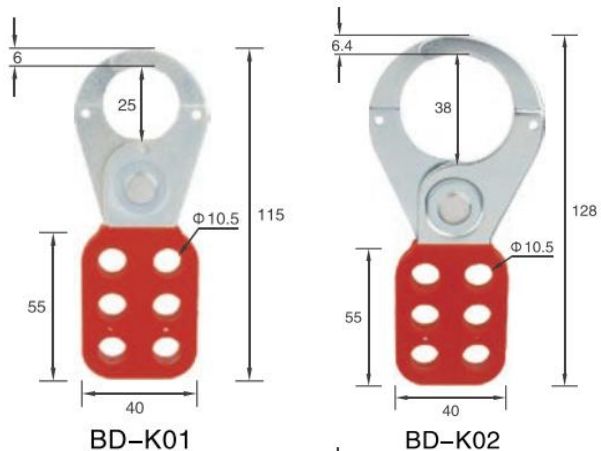

NYLONOWA BLOKADA HASP

- Stop aluminium o wysokiej ognioodporności.
- Stosować w miejscach, w których wymagana jest izolacja i blokada zasilania elektrycznego oraz gdzie występują wysokie wymagania dotyczące odporności na korozję i wybuchy.

Otwieranie: pchnij w górę i w dół.

Part Code	Description
BD-K41	Allow to 6 padlocks
BD-K42	Allow to 6 padlocks

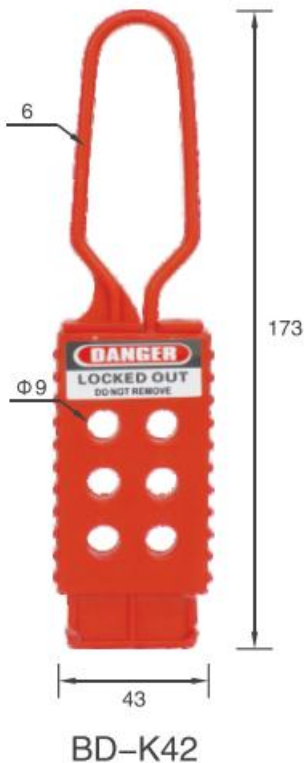

SAFETY PADLOCK

Shackle Type:



With rewritable safety warning signs (can customize luminous PVC material, language, logo, department and so on)



Can print key number

Suitable for use in closed space, such as: chemical, Military, oil extraction and power industry

Normal color: ●RED, ●YLW, ●BLU, ●GRN, ●ORG, ●PRP, ●BLK, WHT,

Other colors can be custom made. Durable non-conductive PA lock body, withstand temperature from -20°C to 150°C, resistance of UV rays.



- Normal version, old version padlock (copper/ zinc alloy lock cylinder)
Key retention-the key cannot be pulled out in the open state, ensuring that the padlock will not be left behind
- New padlock (zinc alloy lock cylinder)
Self-rebound self-reset -lock shackle with self-elastic function
When the padlock is opened, the key is automatically reset to the initial position and the key can be removed.



ZABLOKOWANE ETYKIETY

- a. Blokadę i etykietę można stosować w celu zapewnienia kompleksowej kontroli nad sprzętem, aby chronić pracowników przed wypadkami i sprzęt przed uszkodzeniem.
- b. Użyj z kłódką, aby przypomnieć, że urządzenie zostało zablokowane i nie można go obsługiwać. Można to zrobić tylko otwierane przez tego, kto je zamyka. Umożliwia ludziom poznanie, kto je zamyka i dzięki temu wiedzą, że jest to niebezpieczne obsługiwać urządzenie.
- c. Na etykiecie widnieje ostrzeżenie o bezpieczeństwie w postaci napisów „Niebezpieczeństwo/Nie używać/Ostrożnie” itp., a także puste pole do wypełnienia „Nazwa / Dział/Data” itp.
- d. Zaoferuj dostosowanie języka.

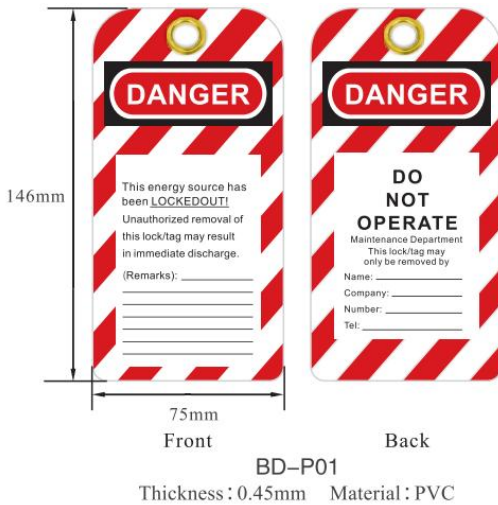

BLOKADA WYŁĄCZNIKA MINIATUROWEGO

- e. Wykonane z tworzywa sztucznego wzmocnionego nylonem PA.
- f. Pasują do większości istniejących typów wyłączników automatycznych w Europie i Azji.
- g. Łatwy montaż za pomocą przycisku lub obrotowego wałka.
- h. Dostępne dla wyłączników jedno- i wielobiegunowych
- i. Zaleca się używanie w połączeniu z kłódką dla większego bezpieczeństwa.
- j. Można stosować kłódkę o średnicy pałąka do 7 mm.

Part Code	Description
BD-D01	POS (Pin Out Standard), hole spacing $\leq 12\text{mm}$
BD-D02	PIS (Pin In Standard), hole spacing $\leq 12\text{mm}$

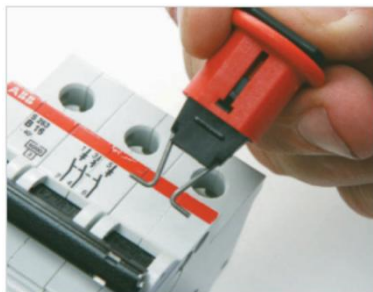

BD-D01(Pin Out Standard)



BD-D02(Pin In Standard)

Blokada wyłącznika zaciskowego

- a. Wykonane z wytrzymałego polipropylenu (PP) i modyfikowanego udarowo PA .
- b. Za pomocą śruby motylkowej zaciśnij blokadę na języczku przełącznika, a następnie pociągnij za pokrywą i zablokuj miejsce zapobiegające poluzowaniu się zacisku.
- c. Nowa konstrukcja ostrza zapewnia mocniejszy chwyt przy mniejszym momencie obrotowym na śrubie motylkowej.
- d. Odłączane bloki zwiększają zakres stosowanych wyłączników.
- e. Blokady mogą obsługiwać kłódki o średnicy pałąka do 7 mm.

Part Code	Description
BD-D12	Can lock handle width ≤ 42 mm



Lockable range: 13mm x 38mm
BD-D12

WIELOFUNKCYJNA BLOKADA WYŁĄCZNIKA MINIATUROWEGO

- a. Wykonane z tworzywa sztucznego wzmocnionego nylonem PA i śrubą mosiężną chromowaną.

- b. Ze śrubami blokującymi, możliwość zablokowania bez użycia narzędzi .
- c. Szerokie zastosowanie: można stosować do wszystkich rodzajów małych i średnich MCCB oraz wszelkie wyłączniki nadprądowe.
- d. Możliwość dostosowania marki stali nierdzewnej .

Part Code	Description
BD-D14	Allow 1 padlock with shackle diameter $\leq 7\text{mm}$



ŚREDNIA BLOKADA WYŁĄCZNIKA

- a. Wykonany z odlewanego ciśnieniowo stopu aluminium, nylonu i ABS, powierzchnia natryskuje metal.
 - b. Ze śrubami blokującymi, możliwość zablokowania bez użycia narzędzi.
 - c. Szeroko stosowane,
- BD-D17, odpowiedni do małych i średnich wyłączników (rączka <12 mm)
- BD-D18, odpowiedni do małych i średnich wyłączników (rączka <16mm)

Part Code	Description
BD-D17	$7.5\text{mm} \leq a \leq 12\text{mm}$
BD-D18	$8\text{mm} \leq a \leq 16\text{mm}$



BD-D17



BD-D18

BLOKADA WTYCZKI ELEKTRYCZNEJ

- Wykonane z wytrzymałego polipropylenu.
- Podwójnie otwarta i sześciokątna konstrukcja blokady, odpowiednia do wszystkich rodzajów wtyczek przemysłowych.
- Mieści od 2 do 4 kłódek o średnicy pałaka mniejszej niż 7 mm, aby je jednocześnie zablokować.

Part Code	Description
BD-D41	51mm(height)*51mm(thickness)*89mm(width), for cable diameter 13mm
BD-D42	65mm(height)*65mm(thickness)*118mm(width), for cable diameter 20mm

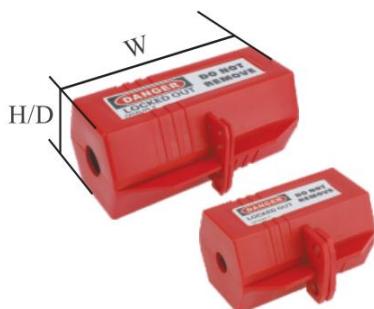

REGULOWANA BLOKADA ZAWORU KULOWEGO

- a. Wykonane z polipropylenu PP.
- b. Zastosowane rozmiary:
BD-F01 blokuje rury o średnicy od 13 mm (1/2") do 64 mm (2 1/2")
- c. Maksymalna średnica pałaka kłódki: 9 mm
- d. Kolor: czerwony, inne kolory wymagają dostosowania.

Part Code	Description
BD-F01	Suitable for 13mm(1/2")to 64mm(2 1/2")pipes



REGULOWANA BLOKADA ZAWORU ZASUWOWEGO

- a. Wykonane z polipropylenu PP.
- b. Zakres blokady można regulować. Zablokuj pokrętko ręczny zawór o średnicy 25mm-165mm(1"-6.5").
- c. Zamykane na jedną kłódkę, średnica pałaka maks. 7 mm.
- d. Kolor: czerwony, inne kolory wymagają dostosowania. Dostępne jest etykietowanie .

Part Code	Description
BD-F16	Valve rod diameter 25mm-165mm(1"-6.5")



REGULOWANA BLOKADA LINKOWA

e. Wykonane z odpornego na uderzenia tworzywa sztucznego PC, dostępne również inne kolory.

f. Zastosowano kabel o długości 1,8 metra, warstwa zewnętrzna Kabel wykonany jest z odpornego na promieniowanie UV P VC (średnica 6 mm), kabel może być dostosowany do różnych długości i kolorów.

g. Wytrzymuje dodatkowe temperatury od -46°C do 149°C .

h. Zamykany na 4 kłódki, średnica pałąka kłódki mniejsza niż 7 mm.

Part Code	Description
BD-L11-1	Cable specification:4mm*1.8m
BD-L11-2	Cable specification:6mm*1.8m





BD-L11

Producent: Shanghaimuxinmuyeyouxiangongsi

Adres: Baoshanqu Shuangchenglu 803long 11hao 1602A-1609shi
Szanghaj

Importowane do AUS: SIHAO PTY LTD, 1 ROKEVA
STREETEASTWOOD NSW 2122 Australia

Importowane do USA: Sanven Technology Ltd.

Apartament 250 , 9166 Anaheim Place, Rancho Cucamonga, CA 91730



SHUNSHUN GmbH
Römeräcker 9 Z2021,76351
Linkenheim-Hochstetten, Germany
euvertreter@gmail.com
+49 1727041930



Pooledas Group Ltd
Unit 5 Albert Edward House, The
Pavilions Preston, United Kingdom
pooledas123@gmail.com
Tel: 01772418127

Wyprodukowano w Chinach

VEVOR[®]

TOUGH TOOLS, HALF PRICE

Techniczny Wsparcie i certyfikat e-gwarancji

www.vevor.com/support

VEVOR[®]

TOUGH TOOLS, HALF PRICE

Technisch Support und E-Garantie-Zertifikat

www.vevor.com/support

LOCKOUT-TAGOUT-KIT

Benutzerhandbuch

We continue to be committed to provide you tools with competitive price.

"Save Half", "Half Price" or any other similar expressions used by us only represents an estimate of savings you might benefit from buying certain tools with us compared to the major top brands and does not necessarily mean to cover all categories of tools offered by us. You are kindly reminded to verify carefully when you are placing an order with us if you are actually saving half in comparison with the top major brands.

VEVOR®

TOUGH TOOLS, HALF PRICE

LOCKOUT TAGOUT KIT

MODELL: BY00 2



NEED HELP? CONTACT US!

Have product questions? Need technical support? Please feel free to contact us:

Technical Support and E-Warranty Certificate
www.vevor.com/support

This is the original instruction, please read all manual instructions carefully before operating. VEVOR reserves a clear interpretation of our user manual. The appearance of the product shall be subject to the product you received. Please forgive us that we won't inform you again if there are any technology or software updates on our product.

SAFETY INSTRUCTIONS

WARNUNG:

Lesen Sie dieses Material, bevor Sie dieses Produkt verwenden. Andernfalls kann es zu schweren Verletzungen kommen.

Vorsichtsmaßnahmen bei der Montage

1. Führen Sie die Montage nur gemäß dieser Anleitung durch. Eine unsachgemäße Montage kann zu Gefahren führen.
2. Tragen Sie während der Montage eine Schutzbrille und Arbeitshandschuhe.
3. Halten Sie den Versammlungsbereich sauber und gut beleuchtet.
4. Halten Sie während der Montage unbeteiligte Zuschauer vom Bereich fern.
5. Nicht zusammenbauen, wenn Sie müde sind oder unter Einfluss von Alkohol, Drogen oder Medikamenten stehen.
6. Die Produktfunktionen gelten nur für ordnungsgemäß und vollständig montierte Produkte.
7. Lockout-Tagout-Kit sicher getragen werden kann .
8. Weitere Informationen zu den auf den folgenden Seiten aufgeführten Teilen finden Sie im Montagediagramm dieses Handbuchs. Packen Sie alle Teile in einem sauberen Arbeitsbereich aus und trennen Sie sie.

Vorsichtsmaßnahmen treffen

1. SETZEN ODER STELLEN SIE SICH NICHT AUF DIESEN GEGENSTAND.
2. Dieses Produkt ist kein Spielzeug. Erlauben Sie Kindern nicht, mit oder in der Nähe dieses Artikels zu spielen.
3. Kapazitäten nicht überschreiten.
4. Lockout-Tagout-Kit sicher tragen kann .
5. Nur bestimmungsgemäß verwenden.
6. Vor jedem Gebrauch prüfen; nicht verwenden, wenn Teile lose oder beschädigt sind.

BEWAHREN SIE DIESES HANDBUCH AUF

PRODUCT PARAMETER

Modell	BY00 2
Anzahl der Sets	42
Produktgröße	495*300*300 mm

PARTS LIST

Name	Code	Men ge
Aufbewahrungskoffer	Z30	1
Sicherheitsvorhängeschloss	G01 (2 Schlüssel pro Schloss)	4
Lockout/Tagout	P01	16
PA-beschichteter Stahlbügel	K01	2
	K02	2
Haspe aus nylonbeschichtetem Stahl	K42	2
Verriegelung für Miniatur-Leistungsschalter	T01 - Die wunderbare Welt der Träume	2

	T02 - Die wunderbare Welt der Träume	2
Klemmbare Leistungsschalterverriegelung	T12 - Die wunderbare Welt des Lebens	2
Multifunktions-Miniatur-Leistungsschalterverriegelung	T14 - Die wunderbare Welt der Träume	2
Verriegelung für mittleren Leistungsschalter	T17 - Die wunderbare Welt der Träume	1
	T18 - Die wunderbare Welt der Träume	1
Elektrische Steckersperre	T41 - Die wunderbare Welt der Träume	1
	T42 - Die wunderbare Welt der Träume	1
Einstellbare Kugelhahnverriegelung	F01	1
Einstellbare Absperrklappe	F16	1

Einstellbare Kabelverriegelung	L11	1
Kabelbinder	/	16

INSTRUCTIONS

STARAGE-KOFFER



Model:: Z30

Size: 400*240*240 mm

PA-BESCHICHTETER STAHLHASPE

- a. Hergestellt aus technischem Kunststoff Nylon PA Spritzguss, verzinkt rostfreie Oberfläche.
- b. Schlosslochdurchmesser: 10,5 mm (2/5 Zoll).
- c. Schlossbügeldurchmesser: 25 mm (1 Zoll) und 38 mm (1,5 Zoll).
- d. Beispielsweise maßgefertigtes Edelstahlmaterial, das Modell dahinter weist ein Pluszeichen „S“ auf.

Part Code	Description
BD-K01	Lock shackle 25mm(1")
BD-K02	Lock shackle 38mm (1.5")

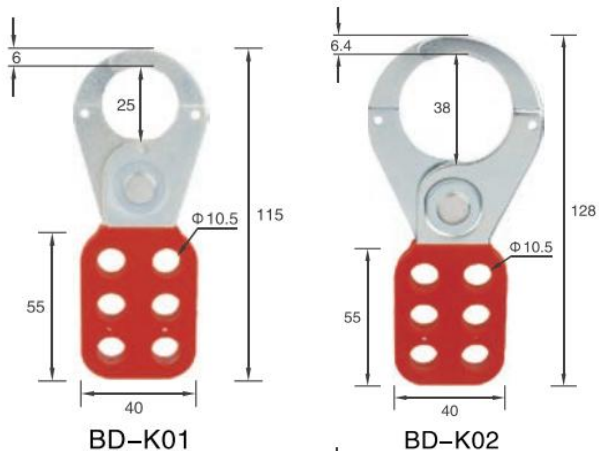

NYLON-VERRIEGELUNGSHASP

- a. Hochfeuerbeständige Aluminiumlegierung.
- b. An Orten anwenden, wo elektrische Stromisolierung und -verriegelung erforderlich sind und hohe Anforderungen an Korrosions- und Explosionsschutz gestellt werden.
- Öffnen: nach oben und unten drücken.

Part Code	Description
BD-K41	Allow to 6 padlocks
BD-K42	Allow to 6 padlocks

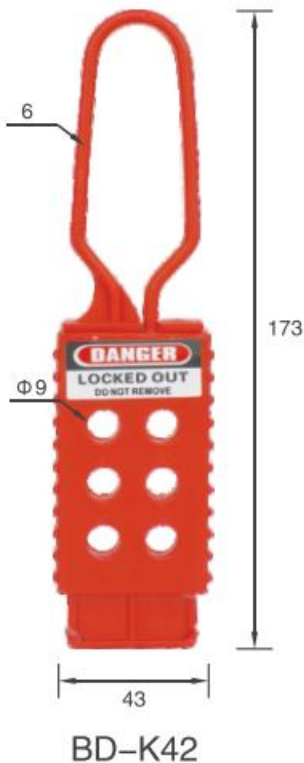

SAFETY PADLOCK

Shackle Type:



With rewritable safety warning signs (can customize luminous PVC material, language, logo, department and so on)



Can print key number

Suitable for use in closed space, such as: chemical, Military, oil extraction and power industry

Normal color: ●RED, ●YLW, ●BLU, ●GRN, ●ORG, ●PRP, ●BLK, WHT,

Other colors can be custom made. Durable non-conductive PA lock body, withstand temperature from -20°C to 150°C, resistance of UV rays.



- Normal version, old version padlock (copper/ zinc alloy lock cylinder)
Key retention-the key cannot be pulled out in the open state, ensuring that the padlock will not be left behind
- New padlock (zinc alloy lock cylinder)
Self-rebound self-reset -lock shackle with self-elastic function
When the padlock is opened, the key is automatically reset to the initial position and the key can be removed.



S PERRIEREFREIHEIT

- Lockout Tagout kann verwendet werden, um eine ganzheitliche Kontrolle der Ausrüstung zu ermöglichen und die Mitarbeiter vor Unfällen zu schützen. und Ausrüstung vor Beschädigungen.
- Mit Vorhängeschloss als Hinweis darauf, dass das Gerät gesperrt ist und nicht bedient werden kann. Es kann nur geöffnet werden kann, indem man es abschließt. So wissen die Leute, wer es abschließt, und wissen, dass es eine Gefahr für sie darstellt. zur Bedienung des Gerätes.
- Auf dem Etikett ist ein Sicherheitswarnhinweis mit den Worten „Gefahr/Nicht bedienen/Achtung“ usw. zu sehen, außerdem sind die Felder „Name / Abteilung/Datum“ usw. frei, die Sie ausfüllen können.
- Bieten Sie eine Sprachanpassung an.

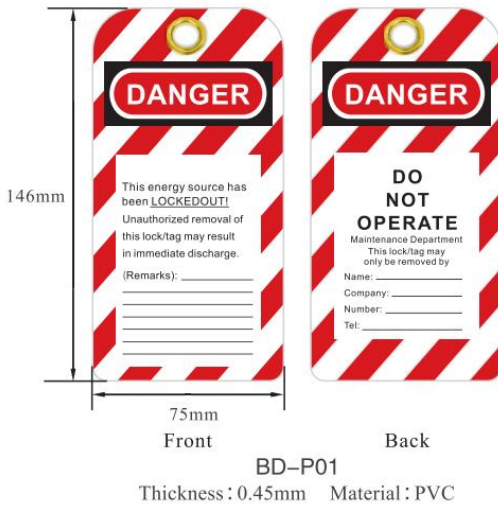

Verriegelung für Miniatur-Leistungsschalter

- e. Hergestellt aus mit technischem Kunststoff verstärktem Nylon PA.
- f. Passend für die meisten vorhandenen Typen europäischer und asiatischer Leistungsschalter.
- g. Einfache Installation mit Hilfe eines Druckknopfs oder einer Drehrolle.
- h. Verfügbar für ein- und mehrpolige Leistungsschalter
- i. Für zusätzliche Sicherheit wird die Verwendung in Kombination mit einem Vorhängeschloss empfohlen.
- j. Kann Vorhängeschlösser mit einem Bügeldurchmesser bis zu 7 mm verwenden.

Part Code	Description
BD-D01	POS (Pin Out Standard), hole spacing $\leq 12\text{mm}$
BD-D02	PIS (Pin In Standard), hole spacing $\leq 12\text{mm}$

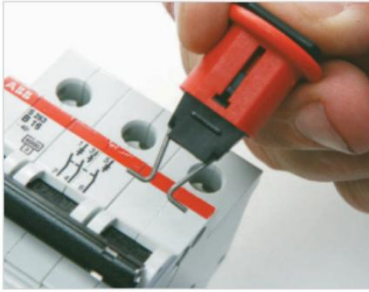

BD-D01(Pin Out Standard)

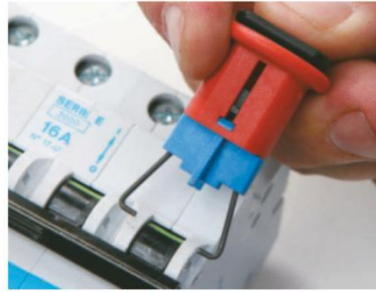

BD-D02(Pin In Standard)

Klemmbarer Leistungsschalter-Verriegelung

- a. Hergestellt aus robustem Polypropylen (PP) und schlagzähmodifiziertem PA .
- b. Mit der Flügelschraube die Sperre sicher auf der Zunge des Schalters festklemmen, dann die Abdeckung abziehen und verriegeln um zu verhindern, dass sich die Klemme löst.
- c. Das neue Klingendesign bietet festeren Halt bei geringerem Drehmoment an der Flügelschraube.
- d. Abnehmbare Klampen erweitern den Bereich der anwendbaren Brecher.
- e. Die Verriegelungen können Vorhängeschlösser mit einem Bügeldurchmesser von bis zu 7 mm aufnehmen.

Part Code	Description
BD-D12	Can lock handle width $\leq 42\text{mm}$



Lockable range: 13mm x 38mm
BD-D12

MULTIFUNKTIONS-MINIATURSCHUTZSCHALTER-VERRIEGELUNG

- a. Hergestellt aus technischem Kunststoff verstärktem Nylon PA und verchromter Messingschraube.
- b. Mit Feststellschrauben, werkzeuglos feststellbar .
- c. Weit verbreitet: anwendbar für alle Arten von kleine und mittelgroße MCCBs und alle Miniatur-Leistungsschalter.
- d. Kann eine individuelle Edelstahlmarke sein .

Part Code	Description
BD-D14	Allow 1 padlock with shackle diameter $\leq 7\text{mm}$



SPERRUNG FÜR MITTLERE LEISTUNGSSCHALTER

- a. Hergestellt aus einer Aluminium-Druckguss-Legierung und Nylon und ABS. Die Oberfläche wirkt metallisch.
- b. Mit Feststellschrauben, werkzeuglos feststellbar.
- c. Weit verbreitet,
BD-D17, geeignet für kleine und mittelgroße Leistungsschalter (Griff < 12 mm)
BD-D18, geeignet für kleine und mittelgroße Leistungsschalter (Griff < 16 mm)

Part Code	Description
BD-D17	$7.5\text{mm} \leq a \leq 12\text{mm}$
BD-D18	$8\text{mm} \leq a \leq 16\text{mm}$

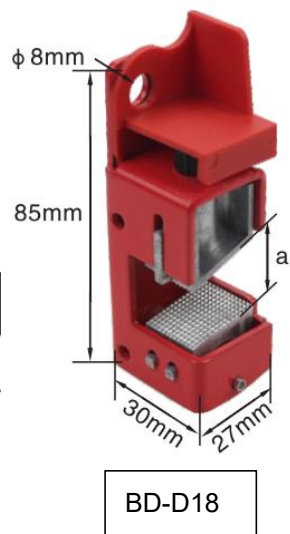
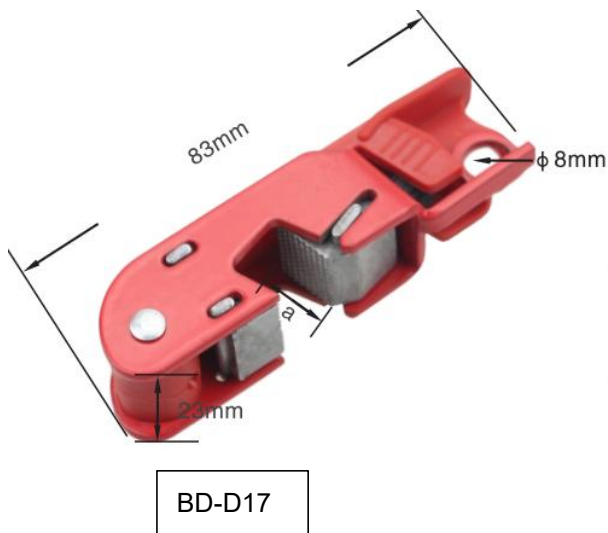

SPERRUNG DES STECKER

- a. Aus robustem Polypropylen.
- b. Doppelt offenes und sechseckiges Verriegelungsdesign, geeignet für alle Arten von Industriesteckern.
- c. Bietet Platz für 2 bis 4 Vorhängeschlösser mit einem Bügeldurchmesser von weniger als 7 mm, um sie gleichzeitig zu verriegeln.

Part Code	Description
BD-D41	51mm(height)*51mm(thickness)*89mm(width), for cable diameter 13mm
BD-D42	65mm(height)*65mm(thickness)*118mm(width), for cable diameter 20mm

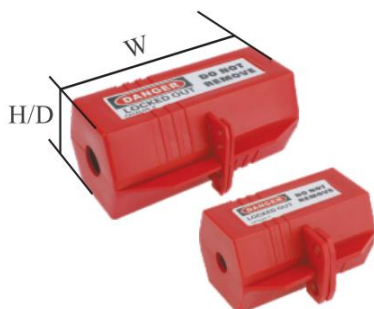

EINSTELLBARE KUGELHAHN-SPERRE

- a. Hergestellt aus Polypropylen PP.
- b. Verwendete Größen:
BD-F01 sperrt Rohre mit einem Durchmesser von 13 mm (1/2 Zoll) bis 64 mm (2 1/2 Zoll) ab.
- c. Vorhängeschloss mit verriegeltem Bügel, max. Durchmesser: 9 mm
- d. d.Farbe: rot, andere Farben müssen angepasst werden.

Part Code	Description
BD-F01	Suitable for 13mm(1/2")to 64mm(2 1/2")pipes



EINSTELLBARE SCHIEBERVENTIL-SPERRE

- a. Hergestellt aus Polypropylen PP.
- b. Sperrbereich kann eingestellt werden. Sperren Sie das Handrad Durchmesser 25 mm – 165 mm (1 Zoll – 6,5 Zoll) Ventil.
- c. Verriegelung durch ein Vorhängeschloss, Bügeldurchmesser max. 7 mm.
- d. Farbe: Rot, andere Farben müssen angepasst werden. Tagout ist verfügbar .

Part Code	Description
BD-F16	Valve rod diameter 25mm-165mm(1"-6.5")



EINSTELLBARE KABELVERRIEGELUNG

e. Hergestellt aus schlagfestem technischem Kunststoff PC, andere Farben können individuell angepasst werden.

f. Verwendet 1,8 Meter Kabel, die äußere Schicht von Das Kabel besteht aus UV-beständigem PVC (Durchmesser 6 mm). Das Kabel kann in verschiedenen Längen und Farben individuell angepasst werden.

g. Hält zusätzlichen Temperaturen von -46 °C bis 149 °C stand.

h. Mit 4 Vorhängeschlössern verriegelt, der Durchmesser des Schlossbügels beträgt weniger als 7 mm.

Part Code	Description
BD-L11-1	Cable specification:4mm*1.8m
BD-L11-2	Cable specification:6mm*1.8m





BD-L11

Hersteller: Shanghaimuxinmuyeyouxiangongsi

Adresse: Baoshanqu Shuangchenglu 803long 11hao 1602A-1609shi
Shanghai

Nach AUS importiert: SIHAO PTY LTD, 1 ROKEVA
STREETEASTWOOD NSW 2122 Australien

In die USA importiert: Sanven Technology Ltd.
Suite 250 , 9166 Anaheim Place, Rancho Cucamonga, CA 91730



SHUNSHUN GmbH
Römeräcker 9 Z2021,76351
Linkenheim-Hochstetten, Germany
euvertreter@gmail.com
+49 1727041930



Pooledas Group Ltd
Unit 5 Albert Edward House, The
Pavilions Preston, United Kingdom
pooledas123@gmail.com
Tel: 01772418127

In China hergestellt

VEVOR[®]

TOUGH TOOLS, HALF PRICE

Technisch Support und E-Garantie-Zertifikat

www.vevor.com/support

VEVOR[®]

TOUGH TOOLS, HALF PRICE

Technique Certificat d'assistance et de garantie électronique

www.vevor.com/support

KIT DE VERROUILLAGE ET D'ÉTIQUETAGE MANUEL D' utilisation

We continue to be committed to provide you tools with competitive price.

"Save Half", "Half Price" or any other similar expressions used by us only represents an estimate of savings you might benefit from buying certain tools with us compared to the major top brands and does not necessarily mean to cover all categories of tools offered by us. You are kindly reminded to verify carefully when you are placing an order with us if you are actually saving half in comparison with the top major brands.

VEVOR®

TOUGH TOOLS, HALF PRICE

LOCKOUT TAGOUT KIT

MODÈLE: BY00 2



NEED HELP? CONTACT US!

Have product questions? Need technical support? Please feel free to contact us:

Technical Support and E-Warranty Certificate
www.vevor.com/support

This is the original instruction, please read all manual instructions carefully before operating. VEVOR reserves a clear interpretation of our user manual. The appearance of the product shall be subject to the product you received. Please forgive us that we won't inform you again if there are any technology or software updates on our product.

SAFETY INSTRUCTIONS

AVERTISSEMENT:

Lisez ce document avant d'utiliser ce produit. Le non-respect de ces instructions peut entraîner des blessures graves.

Précautions de montage

1. Assembler uniquement selon ces instructions. Un assemblage incorrect peut créer des dangers.
2. Portez des lunettes de sécurité et des gants de travail pendant l'assemblage.
3. Gardez la zone de montage propre et bien éclairée.
4. Gardez les spectateurs hors de la zone pendant le montage.
5. Ne pas monter si vous êtes fatigué ou sous l'influence de l'alcool, de drogues ou de médicaments.
6. Les capacités du produit s'appliquent uniquement aux produits correctement et entièrement assemblés.
7. Assemblez-le sur une surface plane, de niveau, dure et lisse capable de supporter en toute sécurité le kit de verrouillage et d'étiquetage .
8. Pour plus d'informations sur les pièces répertoriées dans les pages suivantes, reportez-vous au schéma d'assemblage de ce manuel. Déballer et séparer toutes les pièces dans un espace de travail propre.

Précautions d'emploi

1. NE PAS S'ASSEOIR OU SE TENIR DEBOUT SUR CET ARTICLE.
2. Ce produit n'est pas un jouet. Ne laissez pas les enfants jouer avec ou à proximité de cet article.
3. Ne pas dépasser les capacités.
4. Utiliser uniquement sur une surface plane, dure et lisse capable de supporter en toute sécurité un kit de verrouillage et d'étiquetage entièrement chargé .
5. Utiliser uniquement comme prévu.

6. Inspectez avant chaque utilisation ; ne pas utiliser si des pièces sont desserrées ou endommagées.

CONSERVER CE MANUEL

PRODUCT PARAMETER

Modèle	BY00 2
Nombre d' ensembles	42
Taille du produit	495*300*300 mm

PARTS LIST

Nom	Code	qté
Étui de rangement	Z30	1
Cadenas de sécurité	G01 (2 clés par serrure)	4
Verrouillage et étiquetage	P01	16
Moraillon en acier revêtu de PA	K01	2
	K02	2
Moraillon en acier recouvert de nylon	K42	2
Disjoncteur miniature de verrouillage	D01	2
	D02	2

Blocage de disjoncteur à pince	D12	2
Disjoncteur miniature multifonction	D14	2
Disjoncteur de sécurité moyen	D17	1
	D18	1
Blocage de la prise électrique	D41	1
	D42	1
Verrouillage réglable du robinet à boisseau sphérique	F01	1
Verrouillage réglable de la vanne à guillotine	F16	1
Verrouillage de câble réglable	L11	1
Collier de serrage	/	16

INSTRUCTIONS

ÉTUI STORAGE



Model:: Z30

Size: 400*240*240 mm

Morillon en acier revêtu de PA

- Fabriqué en plastique technique nylon PA moulé par injection, galvanisé surface antirouille.
- Diamètre du trou de verrouillage : 10,5 mm (2/5 ").
- Diamètre de l'anse du verrou : 25 mm (1 ") et 38 mm (1,5 ").
- Comme le matériau en acier inoxydable fabriqué sur mesure, le modèle derrière plus "S".

Part Code	Description
BD-K01	Lock shackle 25mm(1")
BD-K02	Lock shackle 38mm (1.5")

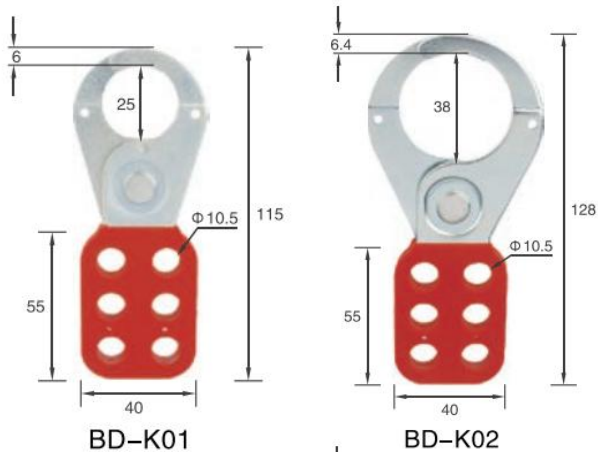

MORCEAU DE VERROUILLAGE EN NYLON

- a. Alliage d'aluminium hautement résistant au feu.
 - b. S'applique aux endroits où l'isolation et le verrouillage de l'alimentation électrique sont nécessaires et ont des exigences élevées en matière de résistance à la corrosion et aux explosions,
- Ouverture : pousser vers le haut et vers le bas.

Part Code	Description
BD-K41	Allow to 6 padlocks
BD-K42	Allow to 6 padlocks

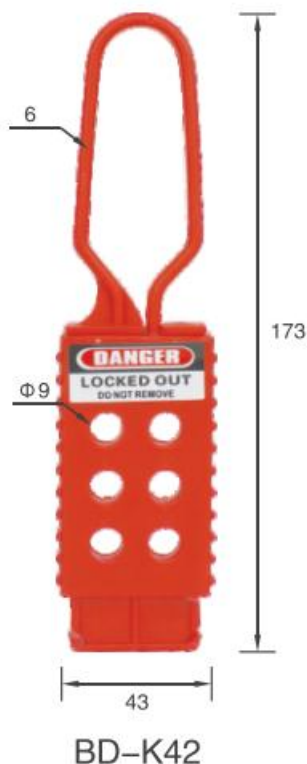

SAFETY PADLOCK

Shackle Type:



Steel shackle Nylon shackle Short/ultra short shackle
 Long steel shackle Long nylon shackle Cable shackle

With rewritable safety warning signs (can customize luminous PVC material, language, logo, department and so on)



Can print key number



Suitable for use in closed space, such as: chemical, Military, oil extraction and power industry

Normal color: ●RED, ●YLW, ●BLU, ●GRN, ●ORG, ●PRP, ●BLK, WHT,

Other colors can be custom made. Durable non-conductive PA lock body, withstand temperature from -20°C to 150°C, resistance of UV rays.



Copper cylinder Zinc alloy cylinder

- Normal version, old version padlock (copper/ zinc alloy lock cylinder)
Key retention-the key cannot be pulled out in the open state, ensuring that the padlock will not be left behind
- New padlock (zinc alloy lock cylinder)
Self-rebound self-reset -lock shackle with self-elastic function
When the padlock is opened, the key is automatically reset to the initial position and the key can be removed.



(Unité: mm)

Verrouillage et étiquetage

- a. Le verrouillage et l'étiquetage peuvent être utilisés pour effectuer un contrôle global de l'équipement afin de protéger les travailleurs contre les accidents. et l'équipement contre les dommages.
- b. Utiliser avec un cadenas pour rappeler que l'appareil a été verrouillé et ne peut pas être utilisé. Il ne peut être utilisé que ouvert par celui qui le verrouille. Cela permet aux gens de savoir qui le verrouille et ainsi ils savent qu'il est dangereux pour faire fonctionner l'appareil.
- c. Sur l'étiquette, vous pouvez voir les avertissements de sécurité « Danger/Ne pas utiliser/Attention », etc., ainsi que « Nom / Service/Date », etc., que vous pouvez remplir.
- d. Offrir une personnalisation linguistique.



DISPOSITIF DE VERROUILLAGE DE DISJONCTEUR MINIATURE

- e. Fabriqué en nylon PA renforcé de plastique technique.
- f. Convient à la plupart des types de disjoncteurs européens et asiatiques existants.
- g. S'installe facilement à l'aide d'un bouton poussoir ou d'un rouleau rotatif.
- h. Disponible pour disjoncteur unipolaire et multipolaire

- i. Il est recommandé de l'utiliser en combinaison avec un cadenas pour plus de sécurité.
- j. Peut utiliser des cadenas avec un diamètre d'anse jusqu'à 7 mm.

Part Code	Description
BD-D01	POS (Pin Out Standard), hole spacing $\leq 12\text{mm}$
BD-D02	PIS (Pin In Standard), hole spacing $\leq 12\text{mm}$

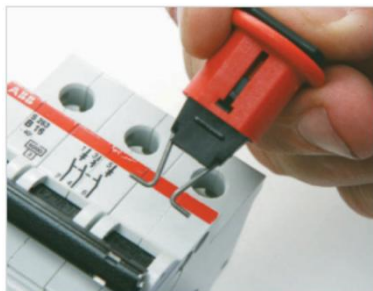

BD-D01(Pin Out Standard)



BD-D02(Pin In Standard)

DISPOSITIF DE BLOCAGE DE DISJONCTEUR À PINCE

- a. Fabriqué en polypropylène PP robuste et PA modifié aux chocs .
- b. Utilisez la vis à oreilles pour fixer solidement le verrouillage sur la languette de l'interrupteur, puis tirez le couvercle et verrouillez-le. endroit pour empêcher le desserrage de la pince.
- c. La nouvelle conception de la lame offre une prise plus serrée avec moins de couple sur la vis à oreilles.
- d. Les taquets amovibles élargissent la gamme de disjoncteurs applicables.
- e. Les dispositifs de verrouillage peuvent accepter des cadenas avec un diamètre d'anse jusqu'à 7 mm.

Part Code	Description
BD-D12	Can lock handle width $\leq 42\text{mm}$



Lockable range: 13mm x 38mm
BD-D12

DISPOSITIF DE VERROUILLAGE DE DISJONCTEUR MINIATURE MULTIFONCTION

- a. Fabriqué en nylon PA renforcé de plastique technique et vis en laiton chromé.
- b. Avec vis de verrouillage, peut être verrouillé sans outils .
- c. Largement utilisé : applicable à tous les types de MCCB de petite et moyenne taille, et tout disjoncteur miniature.
- d. Peut être personnalisé en acier inoxydable .

Part Code	Description
BD-D14	Allow 1 padlock with shackle diameter $\leq 7\text{mm}$



DISPOSITIF DE VERROUILLAGE DE DISJONCTEUR MOYEN

a. Fabriqué en alliage d'aluminium moulé sous pression, en nylon et en ABS, la surface pulvérisée du métal.

b. Avec vis de verrouillage, peut être verrouillé sans outils.

c. Largement utilisé,

BD-D17, convient aux disjoncteurs de petite et moyenne taille (poignée < 12 mm)

BD-D18, convient aux disjoncteurs de petite et moyenne taille (poignée < 16 mm)

Part Code	Description
BD-D17	$7.5\text{mm} \leq a \leq 12\text{mm}$
BD-D18	$8\text{mm} \leq a \leq 16\text{mm}$

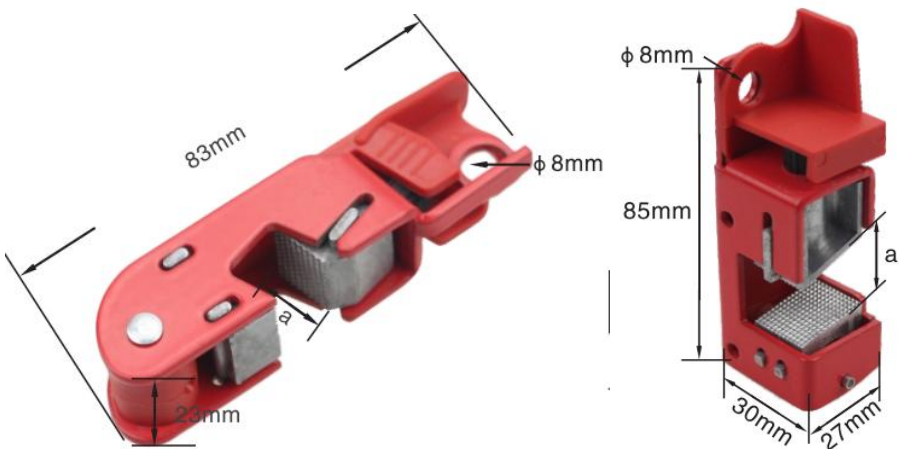

BD-D17

BD-D18

BLOCAGE DE PRISE ELECTRIQUE

- Fabriqué en polypropylène robuste.
- Conception à double ouverture et verrouillage hexagonal, adaptée à tous les types de fiches industrielles.
- Peut accueillir 2 à 4 cadenas avec un diamètre de manille inférieur à 7 mm pour le verrouiller en même temps.

Part Code	Description
BD-D41	51mm(height)*51mm(thickness)*89mm(width), for cable diameter 13mm
BD-D42	65mm(height)*65mm(thickness)*118mm(width), for cable diameter 20mm

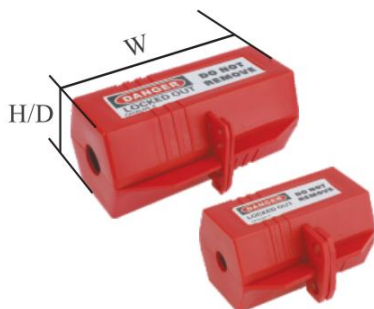

VERROUILLAGE DE VANNE À BILLE RÉGLABLE

- Fabriqué en polypropylène PP.
- Tailles appliquées :
Le BD-F01 verrouille les tuyaux de 13 mm (1/2") à 64 mm (2 1/2") de diamètreb
- Diamètre max de l'anse verrouillée par cadenas : 9 mm
- d. Couleur : rouge, les autres couleurs doivent être personnalisées.

Part Code	Description
BD-F01	Suitable for 13mm(1/2")to 64mm(2 1/2")pipes



VERROUILLAGE DE VANNE À GUILLOTINE RÉGLABLE

- a. Fabriqué en polypropylène PP.
- b. La plage de verrouillage peut être ajustée. Verrouillez le volant diamètre de la valve 25mm-165mm(1"-6,5").
- c. Verrouillé par un cadenas, diamètre de l'anse verrouillée max 7 mm.
- d. Couleur : rouge, d'autres couleurs doivent être personnalisées. L'étiquetage est disponible .

Part Code	Description
BD-F16	Valve rod diameter 25mm-165mm(1"-6.5")



BLOCAGE DE CÂBLE RÉGLABLE

- e. Fabriqué en plastique technique PC résistant aux chocs, d'autres couleurs peuvent être personnalisées.
- f. Câble utilisé de 1,8 mètre, la couche extérieure de le câble est fabriqué en PVC anti-UV (diamètre 6 mm), le câble peut être personnalisé avec différentes longueurs et couleurs.
- g. Résiste à des températures supplémentaires de -46°C à 149°C.
- h. Verrouillé avec 4 cadenas, le diamètre de l'anse du verrou est inférieur à 7 mm.

Part Code	Description
BD-L11-1	Cable specification:4mm*1.8m
BD-L11-2	Cable specification:6mm*1.8m



BD-L11

Fabricant : Shanghaimuxinmuyeyouxiangongsi

Adresse : Baoshanqu Shuangchenglu 803long 11hao 1602A-1609shi
Shanghai

Importé en Australie : SIHAO PTY LTD, 1 ROKEVA STREET, ASTWOOD
NSW 2122 Australie

Importé aux États-Unis : Sanven Technology Ltd.

Suite 250 , 9166 Anaheim Place, Rancho Cucamonga, CA 91730



SHUNSHUN GmbH
Römeräcker 9 Z2021,76351
Linkenheim-Hochstetten, Germany
euvertreter@gmail.com
+49 1727041930



Pooledas Group Ltd
Unit 5 Albert Edward House, The
Pavilions Preston, United Kingdom
pooledas123@gmail.com
Tel: 01772418127

Fabriqué en Chine

VEVOR[®]

TOUGH TOOLS, HALF PRICE

Technique Certificat d'assistance et de garantie électronique

www.vevor.com/support

VEVOR[®]

TOUGH TOOLS, HALF PRICE

Technisch Ondersteuning en E-garantiecertificaat

www.vevor.com/support

LOCKOUT TAGOUT-KIT

Gebruikershandleiding

We continue to be committed to provide you tools with competitive price.

"Save Half", "Half Price" or any other similar expressions used by us only represents an estimate of savings you might benefit from buying certain tools with us compared to the major top brands and does not necessarily mean to cover all categories of tools offered by us. You are kindly reminded to verify carefully when you are placing an order with us if you are actually saving half in comparison with the top major brands.

VEVOR®

TOUGH TOOLS, HALF PRICE

LOCKOUT TAGOUT KIT

MODEL: DOOR00 2



NEED HELP? CONTACT US!

Have product questions? Need technical support? Please feel free to contact us:

Technical Support and E-Warranty Certificate
www.vevor.com/support

This is the original instruction, please read all manual instructions carefully before operating. VEVOR reserves a clear interpretation of our user manual. The appearance of the product shall be subject to the product you received. Please forgive us that we won't inform you again if there are any technology or software updates on our product.

SAFETY INSTRUCTIONS

WAARSCHUWING:

Lees dit materiaal voordat u dit product gebruikt. Als u dit niet doet, kan dit leiden tot ernstig letsel.

Voorzorgsmaatregelen bij de montage

1. Monteer alleen volgens deze instructies. Onjuiste montage kan gevaren opleveren.
2. Draag tijdens de montage een veiligheidsbril en werkhandschoenen.
3. Zorg ervoor dat de verzamelplaats schoon en goed verlicht is.
4. Houd omstanders uit de buurt tijdens de montage.
5. Kom niet bijeen als u moe bent of onder invloed van alcohol, drugs of medicijnen.
6. De producteigenschappen gelden uitsluitend voor correct en volledig gemonteerde producten.
7. Lockout Tagout Kit veilig kan dragen .
8. Voor aanvullende informatie over de onderdelen die op de volgende pagina's worden vermeld, raadpleegt u het montageschema van deze handleiding. Pak alle onderdelen uit en scheid ze in een schone werkruimte.

Neem voorzorgsmaatregelen

1. NIET OP DIT ARTIKEL ZITTEN OF STAAN.
2. Dit product is geen speelgoed. Laat kinderen niet met of in de buurt van dit item spelen.
3. Overschrijd de capaciteit niet.
4. Lockout Tagout Kit veilig kan dragen .
5. Alleen gebruiken zoals bedoeld.
6. Controleer het product voor elk gebruik. Gebruik het niet als er onderdelen loszitten of beschadigd zijn.

BEWAAR DEZE HANDLEIDING

PRODUCT PARAMETER

Model	DOOR00 2
Aantal sets	42
Productgrootte	495*300*300mm

PARTS LIST

Naam	Code	hoeveelheid
Opbergkoffer	Z30	1
Veiligheidshangslot	G01 (2 sleutels per slot)	4
Uitsluiting Tagout	P01	16
PA-gecoate stalen grendel	K01	2
	K02	2
Nylon gecoate stalen beugel	K42	2
Vergrendeling van miniaturstroomonderbrekers	D01	2
	D02	2
Klem-op-schakelaarvergrendeling	D12	2

Multifunctionele miniatuur-stroomonderbrekervergren- deling	D14	2
Vergrendeling van middelgrote stroomonderbrekers	D17	1
	D18	1
Vergrendeling van elektrische stekker	D41	1
	D42	1
Verstelbare kogelkraanvergrendeling	F01	1
Instelbare afsluitervergrendeling	F16	1
Verstelbare kabelvergrendeling	L11	1
Kabelbinder	/	16

INSTRUCTIONS

STORAGE-ZAAK



Model:: Z30

Size: 400*240*240 mm

PA GECOATE STALEN HASP

- Gemaakt van technisch kunststof nylon PA spuitgieten, gegalvaniseerd roestvrij oppervlak.
- Diameter slotgat: 10,5 mm (2/5 ").
- Diameter van de slotbeugel: 25 mm (1 ") en 38 mm (1,5 ").
- Zoals op maat gemaakt roestvrij staal materiaal, het model achter plus "S".

Part Code	Description
BD-K01	Lock shackle 25mm(1")
BD-K02	Lock shackle 38mm (1.5")

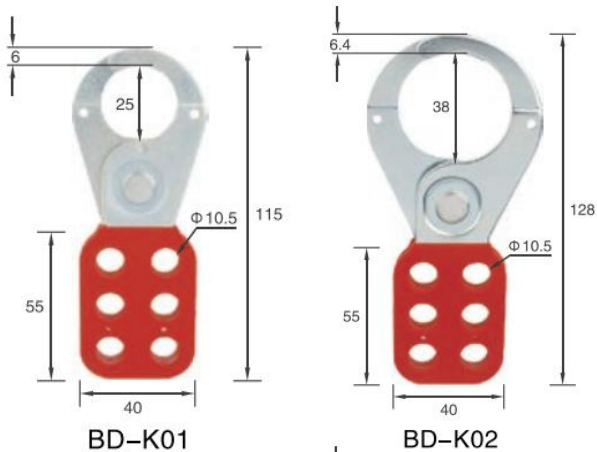

NYLON LOCKOUT HASP

- a. Zeer brandwerende aluminiumlegering.
- b. Toepasbaar op plaatsen waar elektrische isolatie en vergrendeling nodig zijn en waar hoge eisen worden gesteld aan corrosie en explosieveiligheid.

Openen: omhoog en omlaag duwen.

Part Code	Description
BD-K41	Allow to 6 padlocks
BD-K42	Allow to 6 padlocks



BD-K42

SAFETY PADLOCK

Shackle Type:



Steel shackle Nylon shackle Short/ultra short shackle
Long steel shackle Long nylon shackle Cable shackle

With rewritable safety warning signs
(can customize luminous PVC material, language, logo, department and so on)



Can print key number



Suitable for use in closed space, such as: chemical, Military, oil extraction and power industry

Normal color: ●RED, ●YLW, ●BLU, ●GRN, ●ORG, ●PRP, ●BLK, WHT,

Other colors can be custom made.
Durable non-conductive PA lock body, withstand temperature from -20°C to 150°C, resistance of UV rays.



Copper cylinder Zinc alloy cylinder

- Normal version, old version padlock (copper/ zinc alloy lock cylinder)
Key retention-the key cannot be pulled out in the open state, ensuring that the padlock will not be left behind
- New padlock (zinc alloy lock cylinder)
Self-rebound self-reset -lock shackle with self-elastic function
When the padlock is opened, the key is automatically reset to the initial position and the key can be removed.

6 | |



UITSLUITING TAGOUT

- a. Lockout tagout kan worden gebruikt om een holistische controle van de apparatuur uit te voeren om werknemers te beschermen tegen ongevallen en apparatuur tegen schade.
- b. Gebruik met hangslot om eraan te herinneren dat het apparaat is vergrendeld en niet kan worden bediend. Het kan alleen geopend door degene die het op slot doet. Het stelt mensen in staat om te weten wie het op slot doet en zodat ze weten dat het gevaarlijk is voor het apparaat bedienen.
- c. Op het label ziet u de veiligheidswaarschuwing "Gevaar/Niet gebruiken/Voorzichtig" etc. en ook "Naam / afdeling/Datum" etc. is leeg, zodat u het zelf kunt invullen.
- d. Bied taalaanpassingen aan.



MINIATUUR-STROOMONDERBREKERVERGREDELING

- e. Gemaakt van technisch kunststof versterkt nylon PA.
- f. Geschikt voor de meeste bestaande typen Europese en Aziatische stroomonderbrekers.
- g. Eenvoudig te installeren met behulp van een drukknop of draairol.
- h. Beschikbaar voor enkelpolige en meerpolige stroomonderbrekers

- i. Voor extra veiligheid wordt het gebruik in combinatie met een hangslot aanbevolen.
- j. Geschikt voor hangsloten met een beugeldiameter tot 7 mm.

Part Code	Description
BD-D01	POS (Pin Out Standard), hole spacing $\leq 12\text{mm}$
BD-D02	PIS (Pin In Standard), hole spacing $\leq 12\text{mm}$

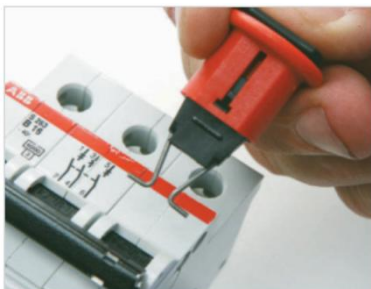

BD-D01(Pin Out Standard)



BD-D02(Pin In Standard)

KLEM-OP SCHAKELAARVERGREDELING

- a. Gemaakt van robuust polypropyleen PP en slagvast PA .
- b. Gebruik de duimschroef om de vergrendeling stevig op de schakelaartong te klemmen, trek vervolgens de kap omhoog en vergrendel deze plaats om te voorkomen dat de klem losraakt.
- c. Het nieuwe ontwerp van het blad zorgt voor een stevigere grip met minder koppel op de duimschroef.
- d. Afneembare noppen vergroten het bereik van toepasbare brekers.
- e. De vergrendelingen zijn geschikt voor hangsloten met een beugeldiameter tot 7 mm.

Part Code	Description
BD-D12	Can lock handle width $\leq 42\text{mm}$



Lockable range: 13mm x 38mm
BD-D12

MULTIFUNCTIONELE MINIATUURSCHAKELAARSVERGREDELING

- Gemaakt van technisch plastic versterkt nylon PA en verchromde messing schroef.
- Met borgschroeven, kan zonder gereedschap worden vergrendeld .
- Breed toepasbaar: toepasbaar op alle soorten kleine en middelgrote MCCB's en alle miniatuur stroomonderbreker.
- Kan op maat worden gemaakt van roestvrij staal .

Part Code	Description
BD-D14	Allow 1 padlock with shackle diameter $\leq 7\text{mm}$



MIDDELGROTE CIRCUIT ONDERBREKER VERGRENDELING

- a. Gemaakt van gegoten aluminiumlegering, nylon en ABS. Het oppervlak is bespoten met metaal.
- b. Met borgschroeven, kan zonder gereedschap worden vergrendeld.
- c. Veel gebruikt,

BD-D17, geschikt voor kleine en middelgrote stroomonderbrekers (handgreep <12 mm)

BD-D18, geschikt voor kleine en middelgrote stroomonderbrekers (handgreep < 16 mm)

Part Code	Description
BD-D17	$7.5\text{mm} \leq a \leq 12\text{mm}$
BD-D18	$8\text{mm} \leq a \leq 16\text{mm}$

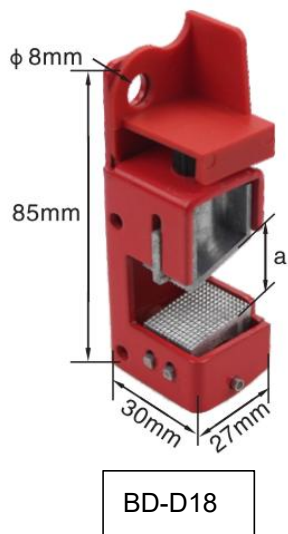
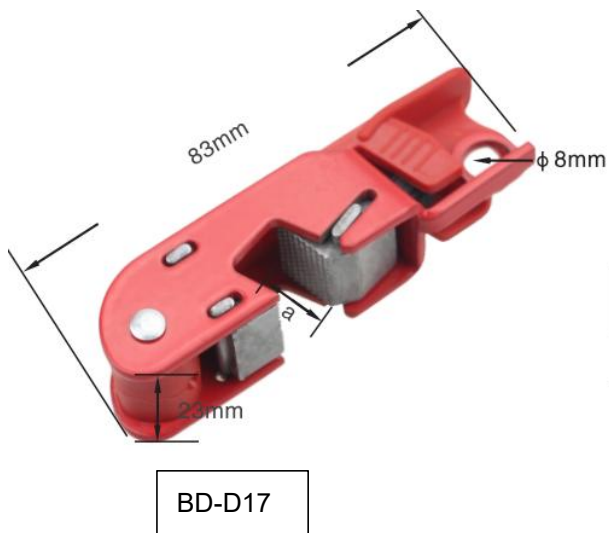

ELEKTRISCHE STEKKERVERGREDELING

- a. Gemaakt van robuust polypropyleen.
- b. Dubbel open en zeshoekig vergrendelingsontwerp, geschikt voor alle soorten industriële stekkers.
- c. Geschikt voor 2 tot 4 hangsloten met een beugeldiameter van minder dan 7 mm, zodat deze tegelijkertijd kunnen worden afgesloten.

Part Code	Description
BD-D41	51mm(height)*51mm(thickness)*89mm(width), for cable diameter 13mm
BD-D42	65mm(height)*65mm(thickness)*118mm(width), for cable diameter 20mm

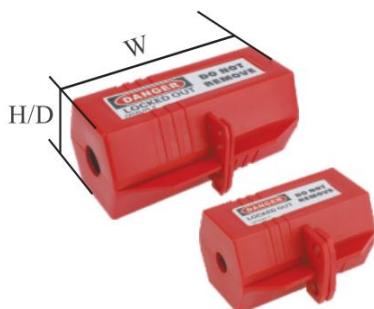

VERSTELBARE KOGELKRAANVERGREDELING

- a. Gemaakt van polypropyleen PP.
- b. Toegepaste maten:
BD-F01 vergrendelt leidingen met een diameter van 13 mm (1/2") tot 64 mm (2 1/2")
- c. Beugel met hangslot, maximale diameter: 9 mm
- d. d.Kleur: rood, andere kleuren moeten worden aangepast.

Part Code	Description
BD-F01	Suitable for 13mm(1/2")to 64mm(2 1/2")pipes



VERSTELBARE AFSLUITKLEPVERGREDELING

- a. Gemaakt van polypropyleen PP.
- b. Het vergrendelingsbereik kan worden aangepast. Vergrendel het handwiel diameter 25mm-165mm(1"-6.5") klep.
- c. Afsluitbaar met één hangslot, diameter van de beugel max. 7 mm.
- d. Kleur: rood, andere kleuren moeten worden aangepast. Tagout is beschikbaar .

Part Code	Description
BD-F16	Valve rod diameter 25mm-165mm(1"-6.5")



VERSTELBARE KABELVERGREDELING

- e. Gemaakt van slagvast PC-kunststof. Andere kleuren kunnen op maat worden gemaakt.
- f. Gebruikte 1,8 meter kabel, de buitenste laag van De kabel is gemaakt van anti-UV P VC (diameter 6 mm). De kabel kan worden aangepast met verschillende lengtes en kleuren.
- g. Bestand tegen extra temperaturen van -46°C tot 149°C .
- h. Vergrendeld met 4 hangsloten, de diameter van de beugel is kleiner dan 7 mm.

Part Code	Description
BD-L11-1	Cable specification:4mm*1.8m
BD-L11-2	Cable specification:6mm*1.8m





BD-L11

Fabrikant: Shanghaimuxinmuyeyouxiangongsi

Adres: Baoshanqu Shuangchenglu 803long 11hao 1602A-1609shi
Shanghai

Geïmporteerd naar AUS: SIHAO PTY LTD, 1 ROKEVA
STREETEASTWOOD NSW 2122 Australië

Geïmporteerd naar de VS: Sanven Technology Ltd.
Suite 250 , 9166 Anaheim Place, Rancho Cucamonga, CA 91730



SHUNSHUN GmbH
Römeräcker 9 Z2021,76351
Linkenheim-Hochstetten, Germany
euvertreter@gmail.com
+49 1727041930



Pooledas Group Ltd
Unit 5 Albert Edward House, The
Pavilions Preston, United Kingdom
pooledas123@gmail.com
Tel: 01772418127

Gemaakt in China

VEVOR[®]

TOUGH TOOLS, HALF PRICE

Technisch Ondersteuning en E-garantiecertificaat

www.vevor.com/support

VEVOR[®]

TOUGH TOOLS, HALF PRICE

Teknisk Support och e-garanticertifikat

www.vevor.com/support

LOCKOUT TAGOUT KIT

Användarmanual

We continue to be committed to provide you tools with competitive price.

"Save Half", "Half Price" or any other similar expressions used by us only represents an estimate of savings you might benefit from buying certain tools with us compared to the major top brands and does not necessarily mean to cover all categories of tools offered by us. You are kindly reminded to verify carefully when you are placing an order with us if you are actually saving half in comparison with the top major brands.

VEVOR®

TOUGH TOOLS, HALF PRICE

LOCKOUT TAGOUT KIT

MODELL: BY00 2



NEED HELP? CONTACT US!

Have product questions? Need technical support? Please feel free to contact us:

Technical Support and E-Warranty Certificate
www.vevor.com/support

This is the original instruction, please read all manual instructions carefully before operating. VEVOR reserves a clear interpretation of our user manual. The appearance of the product shall be subject to the product you received. Please forgive us that we won't inform you again if there are any technology or software updates on our product.

SAFETY INSTRUCTIONS

WARNING:

Läs detta material innan du använder denna produkt. Underlåtenhet att göra det kan resultera i allvarliga skador.

Försiktighetsåtgärder vid montering

1. Montera endast enligt dessa instruktioner. Felaktig montering kan skapa faror.
2. Använd skyddsglasögon och arbetshandskar vid montering.
3. Håll monteringsområdet rent och väl upplyst.
4. Håll åskådare borta från området under monteringen.
5. Sätt dig inte ihop när du är trött eller påverkad av alkohol, droger eller mediciner.
6. Produktegenskaperna gäller endast för korrekt och färdigmonterade produkter.
7. Montera på en plan, jämn, hård och slät yta som säkert kan stödja Lockout Tagout Kit .
8. För ytterligare information om delarna som listas på följande sidor, se monteringsdiagrammet i denna manual. Packa upp och separera alla delar på ett rent arbetsområde.

Använd försiktighetsåtgärder

1. SIT ELLER STÅ INTE PÅ DETTA FÖREMÅL.
2. Denna produkt är inte en leksak. Låt inte barn leka med eller nära detta föremål.
3. Överskrid inte kapaciteten.
4. Använd endast på en plan, jämn, hård och slät yta som säkert kan bära upp ett fullt laddat Lockout Tagout Kit .
5. Använd endast som avsett.
6. Inspektera före varje användning; Använd inte om delar är lösa eller skadade.

SPARA DENNA MANUAL

PRODUCT PARAMETER

Modell	BY00 2
Antal O f S ets	42
Produktstorlek	495*300*300 mm

PARTS LIST

Namn	Koda	antal
Förvaringsväska	Z30	1
Säkerhetshänglås	G01 (2 nycklar per lås)	4
Lockout Tagout	P01	16
PA-belagd stålhasp	K01	2
	K02	2
Nylonbelagd stålhasp	K42	2
Dvärgbrytare låsning	D01	2
	D02	2
Klämbrytare låsning	D12	2
Multifunktionell miniatyrbrytarlås	D14	2

Medelstor brytare spärr	D17	1
	D18	1
Elektrisk kontaktlås	D41	1
	D42	1
Justerbar kulventilspärr	F01	1
Justerbar spärrventil	F16	1
Justerbar kabelspärr	L11	1
Buntband	/	16

INSTRUCTIONS

STORAGE CASE



Model:: Z30

Size: 400*240*240 mm

PA BELAGD STÅL HASP

- Tillverkad av Engineering plast nylon PA formsprutning, galvaniserad rostsäker yta.
- Låshålets diameter: 10,5 mm (2/5 tum).
- Låsbygeldiameter: 25 mm (1 tum) & 38 mm (1,5 tum).
- Såsom specialtillverkat material i rostfritt stål, modellen bakom plus "S".

Part Code	Description
BD-K01	Lock shackle 25mm(1")
BD-K02	Lock shackle 38mm (1.5")

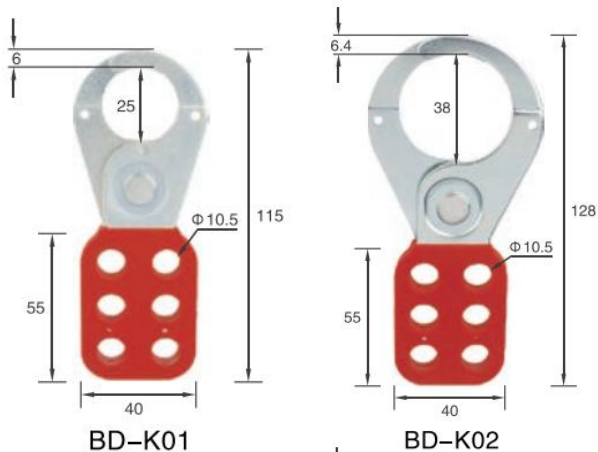

NYLON LOCKOUT HASP

- Hög brandsäker aluminiumlegering.
- Applicera på platser där det behövs elektrisk isolering och lås och har höga krav på korrosiv och explosionssäker, Öppning: tryck upp och ner.

Part Code	Description
BD-K41	Allow to 6 padlocks
BD-K42	Allow to 6 padlocks

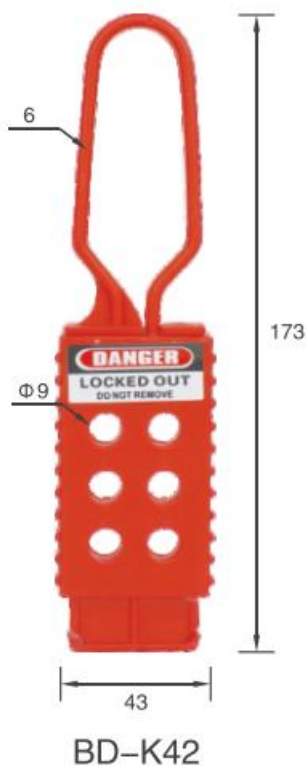

SAFETY PADLOCK

Shackle Type:



Steel shackle Nylon shackle Short/ultra short shackle
Long steel shackle Long nylon shackle Cable shackle

With rewritable safety warning signs
(can customize luminous PVC material,
language, logo, department and so on)



Can print key number



Suitable for use in closed space, such as: chemical, Military, oil extraction and power industry

Normal color: ●RED, ●YLW, ●BLU, ●GRN, ●ORG,
●PRP, ●BLK, WHT,

Other colors can be custom made.
Durable non-conductive PA lock body,
withstand temperature from -20°C to
150°C, resistance of UV rays.



Copper cylinder Zinc alloy cylinder

- Normal version, old version padlock (copper/ zinc alloy lock cylinder)
Key retention-the key cannot be pulled out in the open state, ensuring that the padlock will not be left behind
- New padlock (zinc alloy lock cylinder)

Self-rebound self-reset -lock shackle with self-elastic function
When the padlock is opened, the key is automatically reset to the initial position and the key can be removed.



(Enhet: mm)

L LOCKOUT TAGOUT

- Lockout-tagout kan användas för att göra en holistisk kontroll av utrustningen för att skydda arbetare från olyckor och utrustning från skada.
- Använd med hänglås för att påminna om att enheten är låst och inte kan användas. Det kan bara vara öppnas av den som låser den. Det gör det möjligt för människor att veta vem som låser den och så att de vet att det är en fara använda enheten.
- På taggen kan du se "Fara/Använd inte/försiktighet" etc säkerhetsvarningspråk och även "Namn / avdelning/Datum" etc tomt för dig att fylla i.
- Erbjud språkanpassning.



MINIATYRSKRETSBRYTARE LOCKOUT

- Tillverkad av teknisk plastförstärkt nylon PA.
- Passar de flesta befintliga typer av strömbrytare i Europa och Asien.
- Installeras enkelt med hjälp av en tryckknapp eller roterande rulle.
- Finns för en- och flerpolig brytare
- Rekommenderas att använda i kombination med ett hänglås för ökad säkerhet.
- Kan använda hänglås med en bygeldiameter upp till 7 mm.

Part Code	Description
BD-D01	POS (Pin Out Standard), hole spacing $\leq 12\text{mm}$
BD-D02	PIS (Pin In Standard), hole spacing $\leq 12\text{mm}$

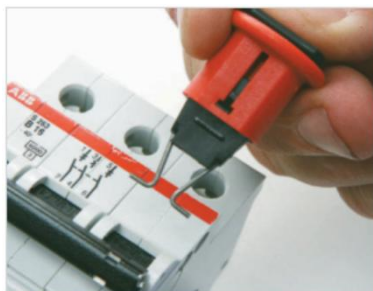

BD-D01(Pin Out Standard)

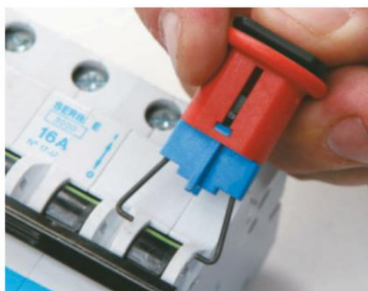

BD-D02(Pin In Standard)

CLAMP-ON BREAKER LOCKOUT

- Tillverkad av robust polypropen PP och slagmodifierad PA .
- Använd tumskruven för att klämma fast lockouten säkert på växlingstungan, dra sedan i locket och lås in plats för att förhindra att klämman lossas.
- Ny bladdesign ger stramare grepp med mindre vridmoment på tumskruven.
- Löstagbara klossar utökar utbudet av tillämpliga brytare.
- Lockouterna kan ta hänslås med en bygeldiameter på upp till 7 mm.

Part Code	Description
BD-D12	Can lock handle width $\leq 42\text{mm}$



Lockable range: 13mm \times 38mm

BD-D12

MULTIFUNKTIONER MINIATYR BREAKER LOCKOUT

- a. Tillverkad av teknisk plastförstärkt nylon PA och förkromad mässingsskruv.
- b. Med låsskruvar, kan låsas utan verktyg .
- c. Mycket använd: tillämplig på alla typer av små och medelstora MCCB och alla dvärgbrytare.
- d. Kan anpassas av märket i rostfritt stål .

Part Code	Description
BD-D14	Allow 1 padlock with shackle diameter $\leq 7\text{mm}$



MEDELKRETSBRYTARE LOCKOUT

- a. Tillverkad av pressgjuten aluminiumlegering & Nylon & ABS, utan sprutar metall.
- b. Med låsskruvar, kan låsas utan verktyg.
- c. Mycket använd,

BD-D17, lämplig för små och medelstora strömbrytare (handtag < 12 mm)

BD-D18, lämplig för små och medelstora strömbrytare (handtag < 16 mm)

Part Code	Description
BD-D17	$7.5\text{mm} \leq a \leq 12\text{mm}$
BD-D18	$8\text{mm} \leq a \leq 16\text{mm}$

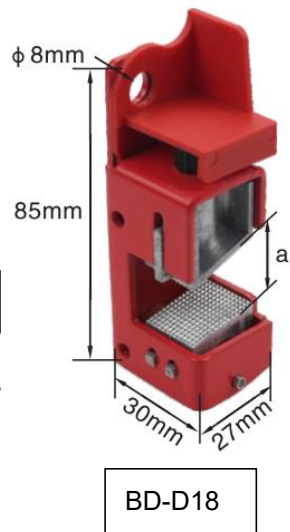
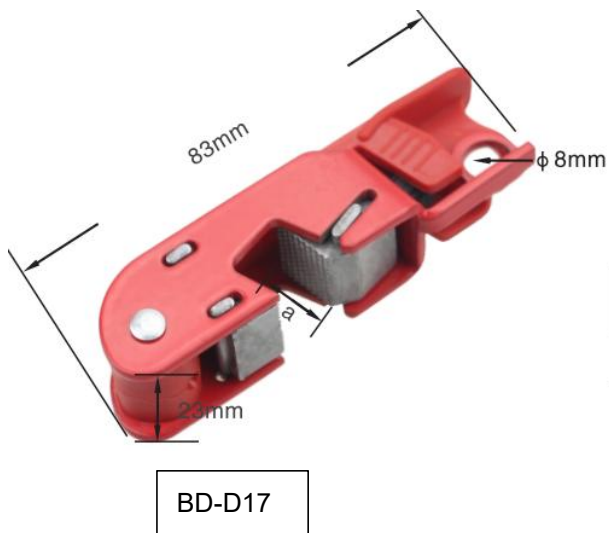

ELKOPPSLÅS

- Tillverkad av robust polypropen.
- Dubbel öppen och sexkantig lockout-design, lämplig för alla typer av industriella pluggar.
- Rymmer 2 till 4 delar av hänglås med bygeldiameter mindre än 7 mm för att låsa det samtidigt.

Part Code	Description
BD-D41	51mm(height)*51mm(thickness)*89mm(width), for cable diameter 13mm
BD-D42	65mm(height)*65mm(thickness)*118mm(width), for cable diameter 20mm

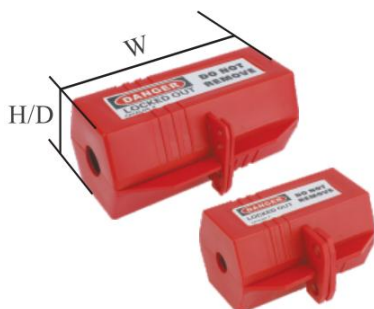

JUSTERBAR KULVENTILSLÅS

- a. Tillverkad av polypropen PP.
- b. Tillämpade storlekar:
BD-F01 låser ut rör från 13 mm (1/2") till 64 mm (2 1/2") i diameterb)
- c. Hänglås låst bygel max diameter: 9mm
- d. Färg: röd, andra färger måste anpassas.

Part Code	Description
BD-F01	Suitable for 13mm(1/2")to 64mm(2 1/2")pipes



JUSTERBAR GRUNDVENTILSLÅS

- a. Tillverkad av polypropen PP.
- b. Låsområdet kan justeras. Lås handratten diameter 25mm-165mm(1"-6,5") ventil.
- c. Låst med ett hänglås, låst bygel diameter max 7mm.
- d. Färg: röd, andra färger måste anpassas. Tagout är tillgänglig .

Part Code	Description
BD-F16	Valve rod diameter 25mm-165mm(1"-6.5")



JUSTERBART KABELLOCKOUT

- e. Tillverkad av slagtålig teknisk plast PC, andra färger kan anpassas.
- f. Används 1,8 meter kabel, det yttre lagret av kabeln är gjord av anti-UV P VC (diameter 6 mm), kabeln kan anpassas med olika längder och färger.
- g. Tål extra temperaturer på -46°C till 149°C.
- h. Låst med 4 hänglås, låsbygelnns diameter är mindre än 7 mm.

Part Code	Description
BD-L11-1	Cable specification:4mm*1.8m
BD-L11-2	Cable specification:6mm*1.8m



BD-L11

Tillverkare: Shanghaimuxinmuyeyouxiangongsi

Adress: Baoshanqu Shuangchenglu 803long 11hao 1602A-1609shi
Shanghai

Importerad till AUS: SIHAO PTY LTD, 1 ROKEVA STREETEASTWOOD
NSW 2122 Australien

Importerad till USA: Sanven Technology Ltd.
Suite 250 , 9166 Anaheim Place, Rancho Cucamonga, CA 91730



SHUNSHUN GmbH
Römeräcker 9 Z2021,76351
Linkenheim-Hochstetten, Germany
euvertreter@gmail.com
+49 1727041930



Pooledas Group Ltd
Unit 5 Albert Edward House, The
Pavilions Preston, United Kingdom
pooledas123@gmail.com
Tel: 01772418127

Tillverkad i Kina

VEVOR[®]

TOUGH TOOLS, HALF PRICE

Teknisk Support och e-garanticertifikat

www.vevor.com/support

VEVOR[®]

TOUGH TOOLS, HALF PRICE

Técnico Certificado de soporte y garantía electrónica

www.vevor.com/support

KIT DE BLOQUEO Y ETIQUETADO

MANUAL DE usuario

We continue to be committed to provide you tools with competitive price.

"Save Half", "Half Price" or any other similar expressions used by us only represents an estimate of savings you might benefit from buying certain tools with us compared to the major top brands and does not necessarily mean to cover all categories of tools offered by us. You are kindly reminded to verify carefully when you are placing an order with us if you are actually saving half in comparison with the top major brands.

VEVOR®

TOUGH TOOLS, HALF PRICE

LOCKOUT TAGOUT KIT

MODELO: POR00 2



NEED HELP? CONTACT US!

Have product questions? Need technical support? Please feel free to contact us:

Technical Support and E-Warranty Certificate
www.vevor.com/support

This is the original instruction, please read all manual instructions carefully before operating. VEVOR reserves a clear interpretation of our user manual. The appearance of the product shall be subject to the product you received. Please forgive us that we won't inform you again if there are any technology or software updates on our product.

SAFETY INSTRUCTIONS

ADVERTENCIA:

Lea este material antes de utilizar este producto. No hacerlo puede provocar lesiones graves.

Precauciones de montaje

1. Realice el montaje únicamente de acuerdo con estas instrucciones. Un montaje inadecuado puede generar peligros.
2. Utilice gafas de seguridad y guantes de trabajo durante el montaje.
3. Mantenga el área de reunión limpia y bien iluminada.
4. Mantenga a los transeúntes fuera del área durante el montaje.
5. No se reúna cuando esté cansado o bajo la influencia del alcohol, drogas o medicamentos.
6. Las capacidades del producto se aplican únicamente a productos ensamblados de forma correcta y completa.
7. Móntelo sobre una superficie plana, nivelada, dura y lisa capaz de soportar de forma segura el kit de bloqueo y etiquetado .
8. Para obtener información adicional sobre las piezas que se enumeran en las páginas siguientes, consulte el diagrama de ensamblaje de este manual. Desembale y separe todas las piezas en un área de trabajo limpia.

Tome precauciones

1. NO SE SIENTA NI SE PARE SOBRE ESTE ARTÍCULO.
2. Este producto no es un juguete. No permita que los niños jueguen con este artículo ni cerca de él.
3. No exceder las capacidades.
4. Úselo únicamente sobre una superficie plana, nivelada, dura y lisa capaz de soportar de forma segura un kit de bloqueo y etiquetado completamente cargado .
5. Úselo únicamente según lo previsto.
6. Inspeccione antes de cada uso; no utilice si las piezas están sueltas o dañadas.

GUARDE ESTE MANUAL

PRODUCT PARAMETER

Modelo	POR00 2
Número de conjuntos	42
Tamaño del producto	495*300*300 milímetros

PARTS LIST

Nombre	Código	cantidad
Estuche de almacenamiento	Z30	1
Candado de seguridad	G01 (2 llaves por cerradura)	4
Bloqueo y etiquetado	P01	16
Cerrojo de acero revestido de PA	K01	2
	K02	2
Cerrojo de acero revestido de nailon	K42	2
Bloqueo de disyuntor en miniatura	D01	2

	D02	2
Bloqueo de disyuntor con abrazadera	D12	2
Bloqueo de interruptor en miniatura multifunción	D14	2
Bloqueo de disyuntor mediano	D17	1
	D18	1
Bloqueo de enchufe eléctrico	D41	1
	D42	1
Bloqueo de válvula de bola ajustable	F01	1
Bloqueo de válvula de compuerta ajustable	F16	1
Bloqueo de cable ajustable	L11	1
Brida para cables	/	16

INSTRUCTIONS

ESTUCHE DE ALMACENAMIENTO



Model:: Z30

Size: 400*240*240 mm

CERROJO DE ACERO RECUBIERTO DE PA

a. Fabricado con nailon PA moldeado por inyección de plástico de ingeniería, galvanizado.

Superficie a prueba de óxido.

b. Diámetro del orificio de la cerradura: 10,5 mm (2/5 ").

c. Diámetro del grillete de bloqueo: 25 mm (1 ") y 38 mm (1,5 ").

d. Como material de acero inoxidable hecho a medida, el modelo detrás más "S".

Part Code	Description
BD-K01	Lock shackle 25mm(1")
BD-K02	Lock shackle 38mm (1.5")

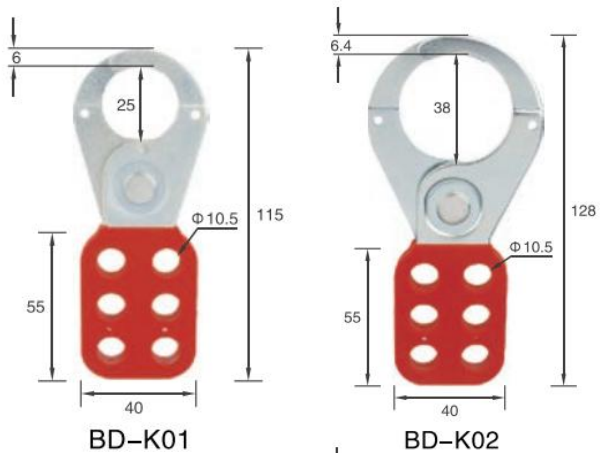

CERROJO DE BLOQUEO DE NYLON

- Aleación de aluminio de alta resistencia al fuego.
 - Aplicar en lugares donde se necesita aislamiento y bloqueo de energía eléctrica y tiene altos requisitos de corrosión y a prueba de explosiones.
- Apertura: empujar hacia arriba y hacia abajo.

Part Code	Description
BD-K41	Allow to 6 padlocks
BD-K42	Allow to 6 padlocks

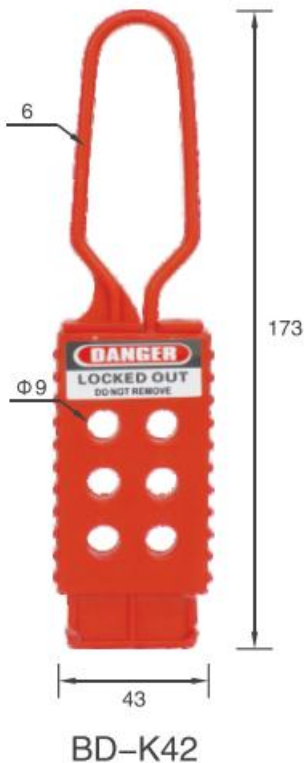

SAFETY PADLOCK

Shackle Type:



With rewritable safety warning signs (can customize luminous PVC material, language, logo, department and so on)



Can print key number

Suitable for use in closed space, such as: chemical, Military, oil extraction and power industry

Normal color: ●RED, ●YLW, ●BLU, ●GRN, ●ORG, ●PRP, ●BLK, WHT,

Other colors can be custom made. Durable non-conductive PA lock body, withstand temperature from -20°C to 150°C, resistance of UV rays.



- Normal version, old version padlock (copper/ zinc alloy lock cylinder)
Key retention-the key cannot be pulled out in the open state, ensuring that the padlock will not be left behind
- New padlock (zinc alloy lock cylinder)
Self-rebound self-reset -lock shackle with self-elastic function
When the padlock is opened, the key is automatically reset to the initial position and the key can be removed.



Y ETIQUETADO

- El bloqueo y etiquetado se puede utilizar para realizar un control integral del equipo para proteger a los trabajadores de accidentes. y equipos contra daños.
- Úselo con candado para recordar que el dispositivo ha sido bloqueado y no se puede utilizar. Solo se puede utilizar con un candado. Abre la puerta quien la cierra. Permite que la gente sepa quién la cierra y que sepa que es peligroso. operar el dispositivo.
- En la etiqueta, puede ver el lenguaje de advertencia de seguridad "Peligro/No operar/Precaución", etc. y también el espacio en blanco "Nombre / departamento/Fecha", etc. para que lo complete.
- Ofrecer personalización del idioma.

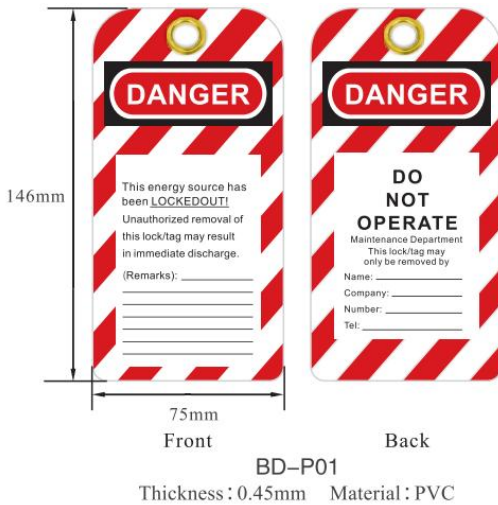

BLOQUEO DE DISYUNTOR MINIATURA

- e. Fabricado con nailon PA reforzado con plástico de ingeniería.
- f. Se adapta a la mayoría de los tipos existentes de disyuntores europeos y asiáticos.
- g. Se instala fácilmente con la ayuda de un botón pulsador o un rodillo giratorio.
- h. Disponible para disyuntores unipolares y multipolares.
- i. Se recomienda utilizar en combinación con un candado para mayor seguridad.
- j. Se pueden utilizar candados con un diámetro de arco de hasta 7 mm.

Part Code	Description
BD-D01	POS (Pin Out Standard), hole spacing $\leq 12\text{mm}$
BD-D02	PIS (Pin In Standard), hole spacing $\leq 12\text{mm}$

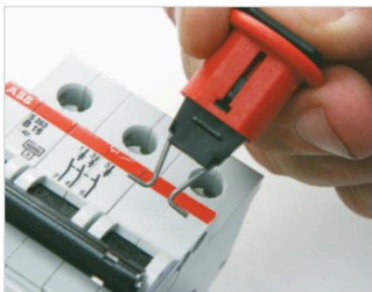

BD-D01(Pin Out Standard)



BD-D02(Pin In Standard)

BLOQUEO DE DISYUNTOR CON ABRAZADERA

- Fabricado con polipropileno resistente PP y PA modificado contra impactos .
- Utilice el tornillo de mariposa para sujetar firmemente el bloqueo en la lengüeta del interruptor, luego tire de la cubierta y bloquéela. Lugar para evitar que la abrazadera se afloje.
- El nuevo diseño de la hoja proporciona un agarre más firme con menos torsión en el tornillo de mariposa.
- Las abrazaderas desmontables amplían la gama de rompedores aplicables.
- Los bloqueos pueden aceptar candados con un diámetro de arco de hasta 7 mm.

Part Code	Description
BD-D12	Can lock handle width ≤ 42 mm



Lockable range: 13mm x 38mm
BD-D12

BLOQUEO DE DISYUNTOR MINIATURA MULTIFUNCIÓN

- Fabricado con nailon PA reforzado con plástico de ingeniería y tornillo de latón cromado.

- b. Con tornillos de bloqueo, se puede bloquear sin herramientas .
- c. Ampliamente utilizado: aplicable a todo tipo de MCCB de tamaño pequeño y mediano, y cualquier disyuntor miniatura
- d. Se puede personalizar la marca de acero inoxidable .

Part Code	Description
BD-D14	Allow 1 padlock with shackle diameter ≤ 7 mm



BLOQUEO DE DISYUNTOR MEDIANO

a. Hecho de aleación de aluminio fundido a presión, nailon y ABS, la superficie rocía metal.

b. Con tornillos de bloqueo, se puede bloquear sin herramientas.

c. Ampliamente utilizado,

BD-D17, adecuado para disyuntores de tamaño pequeño y mediano (mango <12 mm)

BD-D18, adecuado para disyuntores de tamaño pequeño y mediano (mango <16 mm)

Part Code	Description
BD-D17	$7.5\text{mm} \leq a \leq 12\text{mm}$
BD-D18	$8\text{mm} \leq a \leq 16\text{mm}$

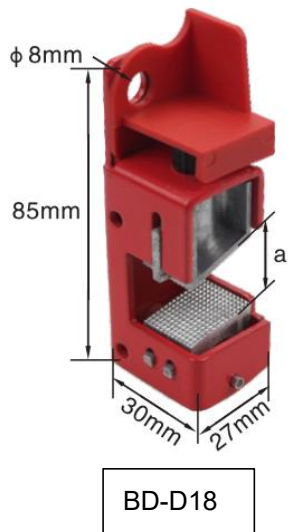
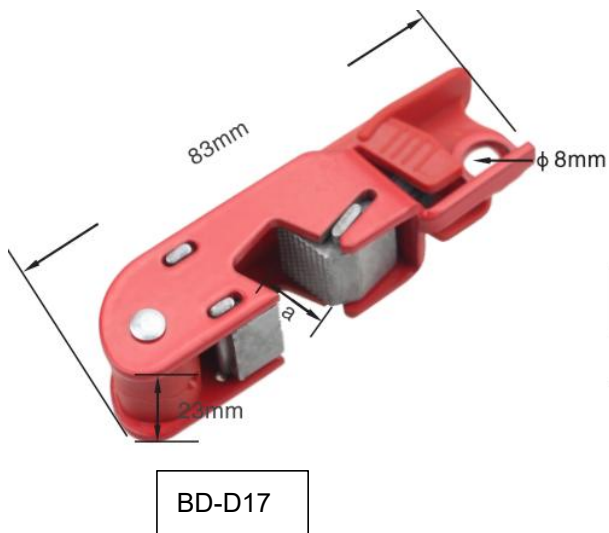

BLOQUEO DE ENCHUFE ELÉCTRICO

- a. Fabricado en polipropileno resistente.
- b. Diseño de doble apertura y bloqueo hexagonal, adecuado para todo tipo de enchufes industriales.
- c. Admite de 2 a 4 candados con un diámetro de arco inferior a 7 mm para bloquearlos al mismo tiempo.

Part Code	Description
BD-D41	51mm(height)*51mm(thickness)*89mm(width), for cable diameter 13mm
BD-D42	65mm(height)*65mm(thickness)*118mm(width), for cable diameter 20mm

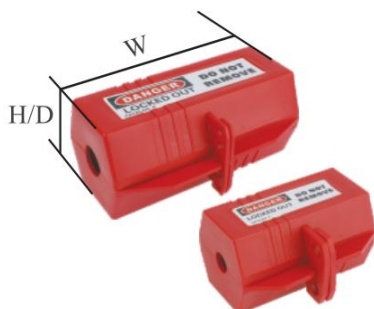

BLOQUEO DE VÁLVULA DE BOLA AJUSTABLE

- a. Fabricado en polipropileno PP.
- b. Tamaños aplicados:
BD-F01 bloquea tuberías de 13 mm (1/2") a 64 mm (2 1/2") de diámetro
- c. Diámetro máximo del arco del candado: 9 mm
- d. Color: rojo, otros colores deben personalizarse.

Part Code	Description
BD-F01	Suitable for 13mm(1/2")to 64mm(2 1/2")pipes



BLOQUEO DE VÁLVULA DE COMPUERTA AJUSTABLE

- a. Fabricado en polipropileno PP.
- b. El rango de bloqueo se puede ajustar. Bloquee el volante. Válvula de diámetro 25 mm-165 mm (1"-6,5").
- c. Bloqueado con un candado, diámetro máximo del grillete bloqueado: 7 mm.
- d. Color: rojo, otros colores deben personalizarse. El etiquetado está disponible .

Part Code	Description
BD-F16	Valve rod diameter 25mm-165mm(1"-6.5")



BLOQUEO DE CABLE AJUSTABLE

- e. Fabricado en plástico de ingeniería PC resistente al impacto, se pueden personalizar otros colores.
- f. Se utilizó un cable de 1,8 metros, la capa exterior de El cable está hecho de PVC anti-UV (diámetro de 6 mm), el cable se puede personalizar con diferentes longitudes y colores.
- g. Soporta temperaturas adicionales de -46°C a 149°C.
- h. Bloqueado con 4 candados, el diámetro del grillete de la cerradura es inferior a 7 mm.

Part Code	Description
BD-L11-1	Cable specification:4mm*1.8m
BD-L11-2	Cable specification:6mm*1.8m



BD-L11

Fabricante: Shanghaimuxinmuyeyouxiangongsi

Dirección: Baoshanqu Shuangchenglu 803long 11hao 1602A-1609shi
Shanghai

Importado a AUS: SIHAO PTY LTD, 1 ROKEVA STREETEASTWOOD
NSW 2122 Australia

Importado a EE. UU.: Sanven Technology Ltd.

Suite 250 , 9166 Anaheim Place, Rancho Cucamonga, CA 91730



SHUNSHUN GmbH
Römeräcker 9 Z2021,76351
Linkenheim-Hochstetten,Germany
euvertreter@gmail.com
+49 1727041930



Pooledas Group Ltd
Unit 5 Albert Edward House, The
Pavilions Preston, United Kingdom
pooledas123@gmail.com
Tel: 01772418127

Hecho en china

VEVOR[®]

TOUGH TOOLS, HALF PRICE

Técnico Certificado de soporte y garantía electrónica

www.vevor.com/support

VEVOR[®]

TOUGH TOOLS, HALF PRICE

Tecnico Supporto e certificato di garanzia elettronica

www.vevor.com/support

KIT DI BLOCCO E DISATTIVAZIONE

MANUALE D' uso

We continue to be committed to provide you tools with competitive price.

"Save Half", "Half Price" or any other similar expressions used by us only represents an estimate of savings you might benefit from buying certain tools with us compared to the major top brands and does not necessarily mean to cover all categories of tools offered by us. You are kindly reminded to verify carefully when you are placing an order with us if you are actually saving half in comparison with the top major brands.

VEVOR[®]

TOUGH TOOLS, HALF PRICE

LOCKOUT TAGOUT KIT

MODELLO: DI00 2



NEED HELP? CONTACT US!

Have product questions? Need technical support? Please feel free to contact us:

Technical Support and E-Warranty Certificate
www.vevor.com/support

This is the original instruction, please read all manual instructions carefully before operating. VEVOR reserves a clear interpretation of our user manual. The appearance of the product shall be subject to the product you received. Please forgive us that we won't inform you again if there are any technology or software updates on our product.

SAFETY INSTRUCTIONS

AVVERTIMENTO:

Leggere questo materiale prima di utilizzare questo prodotto. La mancata osservanza di questa precauzione può causare gravi lesioni.

Precauzioni di montaggio

1. Montare solo secondo queste istruzioni. Un montaggio improprio può creare pericoli.
2. Durante il montaggio indossare occhiali protettivi e guanti da lavoro.
3. Mantenere l'area di riunione pulita e ben illuminata.
4. Durante l'assemblea, tenere gli astanti lontani dall'area.
5. Non riunirsi quando si è stanchi o sotto l'effetto di alcol, droghe o farmaci.
6. Le capacità del prodotto si applicano solo ai prodotti correttamente e completamente assemblati.
7. Montare su una superficie piana, livellata, dura e liscia in grado di sostenere in modo sicuro il kit Lockout Tagout .
8. Per ulteriori informazioni sulle parti elencate nelle pagine seguenti, fare riferimento allo schema di montaggio di questo manuale. Disimballare e separare tutte le parti in un'area di lavoro pulita.

Usare precauzioni

1. **NON SEDERSI O STARE IN PIEDI SU QUESTO OGGETTO.**
2. Questo prodotto non è un giocattolo. Non permettere ai bambini di giocare con o vicino a questo articolo.
3. Non superare le capacità.
4. Utilizzare solo su una superficie piana, livellata, dura e liscia in grado di sostenere in modo sicuro un kit Lockout Tagout completamente carico .
5. Utilizzare solo come previsto.
6. Ispezionare prima di ogni utilizzo; non utilizzare se le parti sono allentate o danneggiate.

SALVA QUESTO MANUALE

PRODUCT PARAMETER

Modello	DI00 2
Numero di set	42
Dimensioni del prodotto	495*300*300 millimetri

PARTS LIST

Nome	Codice	quantità
Custodia di stoccaggio	Z30	1
Lucchetto di sicurezza	G01 (2 chiavi per serratura)	4
Blocco e contrassegno	P01	16
Ganci in acciaio rivestito in PA	K01	2
	K02	2
Ganci in acciaio rivestiti in nylon	K42	2
Blocco dell'interruttore automatico in miniatura	D01	2
	D02	2
Blocco dell'interruttore a pinza	Giorno 12	2

Interruttore di sicurezza multifunzione in miniatura	Giorno 14	2
Blocco dell'interruttore di circuito medio	Giorno 17	1
	Giorno 18	1
Blocco della spina elettrica	D41	1
	D42	1
Blocco valvola a sfera regolabile	F01	1
Blocco valvola a saracinesca regolabile	F16	1
Blocco del cavo regolabile	L11	1
Fascetta per cavi	/	16

INSTRUCTIONS

CASO STARGAGE



Model:: Z30

Size: 400*240*240 mm

CHIUSURA IN ACCIAIO RIVESTITO IN PA

- a. Realizzato in nylon PA di plastica ingegneristica stampato a iniezione, zincato
superficie antiruggine.
- b. Diametro foro serratura: 10,5 mm (2/5 ").
- c. Diametro dell'arco di bloccaggio: 25 mm (1 ") e 38 mm (1,5 ").
- d. Ad esempio, materiale in acciaio inossidabile realizzato su misura, il modello dietro più "S".

Part Code	Description
BD-K01	Lock shackle 25mm(1")
BD-K02	Lock shackle 38mm (1.5")

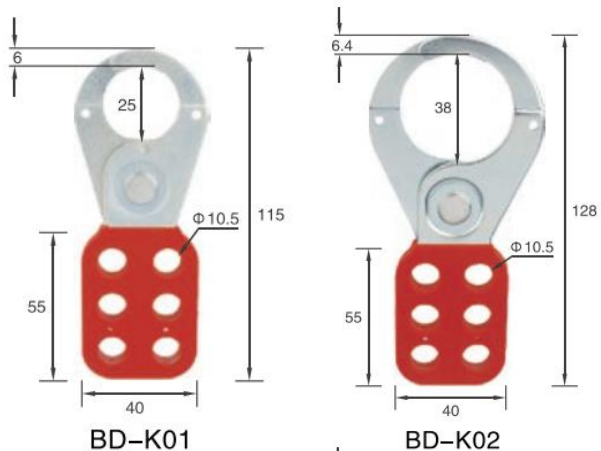

CHIUSURA CON CHIUSURA IN NYLON

- Legg di alluminio altamente resistente al fuoco.
- Applicare in luoghi in cui è necessario l'isolamento e il blocco dell'alimentazione elettrica e sono richiesti elevati requisiti di resistenza alla corrosione e alle esplosioni,

Apertura: spingere verso l'alto e verso il basso.

Part Code	Description
BD-K41	Allow to 6 padlocks
BD-K42	Allow to 6 padlocks

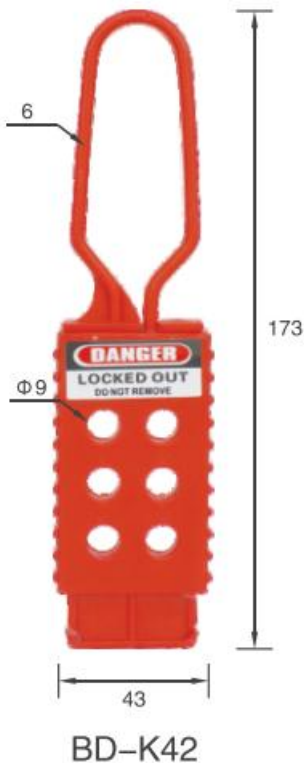

BD-K42

SAFETY PADLOCK

Shackle Type:



With rewritable safety warning signs (can customize luminous PVC material, language, logo, department and so on)



Can print key number

Suitable for use in closed space, such as: chemical, Military, oil extraction and power industry

Normal color: ●RED, ●YLW, ●BLU, ●GRN, ●ORG, ●PRP, ●BLK, WHT,

Other colors can be custom made. Durable non-conductive PA lock body, withstand temperature from -20°C to 150°C, resistance of UV rays.



- Normal version, old version padlock (copper/ zinc alloy lock cylinder)
Key retention-the key cannot be pulled out in the open state, ensuring that the padlock will not be left behind
- New padlock (zinc alloy lock cylinder)
Self-rebound self-reset -lock shackle with self-elastic function
When the padlock is opened, the key is automatically reset to the initial position and the key can be removed.



BLOCCO TAGOUT

- a. Il lockout tagout può essere utilizzato per effettuare un controllo olistico dell'attrezzatura per proteggere i lavoratori dagli incidenti e proteggere le attrezzature da eventuali danni.
- b. Utilizzare con il lucchetto per ricordare che il dispositivo è stato bloccato e non può essere utilizzato. Può essere utilizzato solo aperto da chi lo ha chiuso. Permette alle persone di sapere chi lo ha chiuso e quindi di sapere che è pericoloso per azionare il dispositivo.
- c. Sull'etichetta puoi vedere il testo di avviso di sicurezza "Pericolo/Non usare/Attenzione" ecc. e anche uno spazio vuoto da compilare "Nome / dipartimento/Data" ecc.
- d. Offri la personalizzazione della lingua.

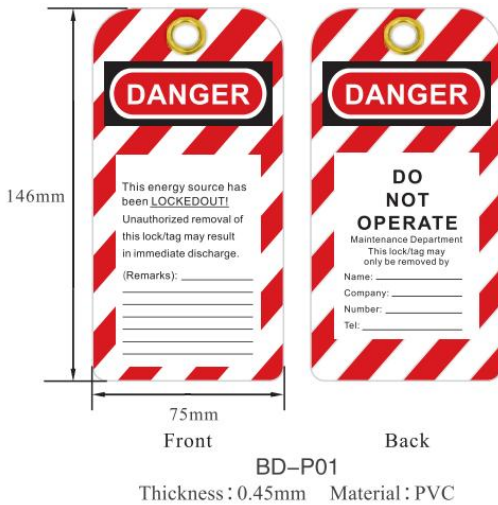

BLOCCO DELL'INTERRUTTORE AUTOMATICO IN MINIATURA

- e. Realizzato in nylon PA rinforzato con plastica tecnica.
- f. Adatto alla maggior parte degli interruttori automatici europei e asiatici esistenti.
- g. Facile da installare mediante l'ausilio di un pulsante o di un rullo rotante.
- h. Disponibile per interruttore unipolare e multipolare
- i. Per una maggiore sicurezza, si consiglia di utilizzarlo insieme a un lucchetto.
- j. Può utilizzare lucchetti con un diametro dell'arco fino a 7 mm.

Part Code	Description
BD-D01	POS (Pin Out Standard), hole spacing $\leq 12\text{mm}$
BD-D02	PIS (Pin In Standard), hole spacing $\leq 12\text{mm}$

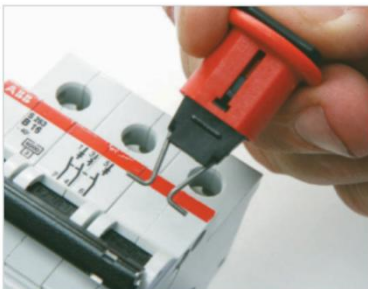

BD-D01(Pin Out Standard)



BD-D02(Pin In Standard)

BLOCCO DELL'INTERRUTTORE A MORSETTO

- a. Realizzato in robusto polipropilene PP e PA antiurto modificato .
- b. Utilizzare la vite a testa zigrinata per fissare saldamente il blocco sulla linguetta dell'interruttore, quindi tirare il coperchio e bloccarlo posto per evitare che il morsetto si allenti.
- c. Il nuovo design della lama garantisce una presa più salda con una coppia inferiore sulla vite a testa zigrinata.
- d. I morsetti staccabili ampliano la gamma di interruttori applicabili.
- e. I dispositivi di blocco possono accettare lucchetti con un diametro dell'arco fino a 7 mm.

Part Code	Description
BD-D12	Can lock handle width ≤ 42 mm



Lockable range: 13mm x 38mm
BD-D12

BLOCCO INTERRUTTORE MINIATURIZZATO MULTIFUNZIONE

- a. Realizzato in nylon rinforzato con plastica ingegneristica PA e vite in ottone cromato.
- b. Con viti di bloccaggio, può essere bloccato senza attrezzi .
- c. Ampiamente utilizzato: applicabile a tutti i tipi di MCCB di piccole e medie dimensioni e qualsiasi interruttore automatico in miniatura.
- d. Può essere personalizzato con il marchio in acciaio inossidabile .

Part Code	Description
BD-D14	Allow 1 padlock with shackle diameter $\leq 7\text{mm}$



BLOCCO INTERRUPTORE CIRCUITO MEDIO

- a. Realizzato in lega di alluminio pressofuso, nylon e ABS, la superficie spruzza metallo.
- b. Con viti di bloccaggio, può essere bloccato senza attrezzi.
- c. Ampiamente utilizzato,

BD-D17, adatto per interruttori automatici di piccole e medie dimensioni (maniglia $< 12\text{ mm}$)

BD-D18, adatto per interruttori automatici di piccole e medie dimensioni (maniglia $< 16\text{ mm}$)

Part Code	Description
BD-D17	$7.5\text{mm} \leq a \leq 12\text{mm}$
BD-D18	$8\text{mm} \leq a \leq 16\text{mm}$

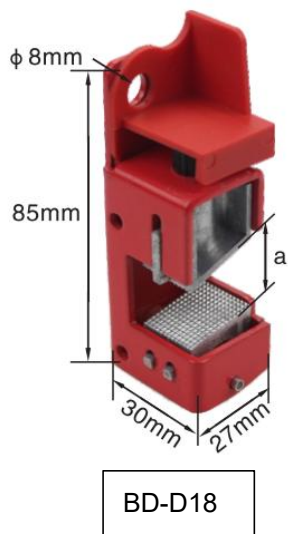
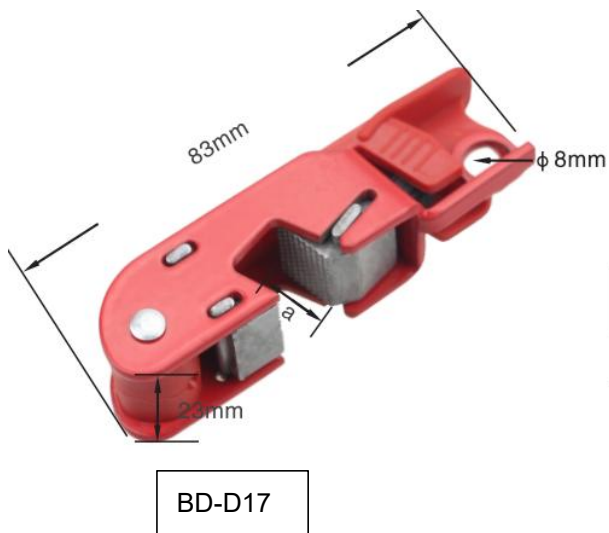

BLOCCO SPINA ELETTRICA

- a. Realizzato in robusto polipropilene.
- b. Design con doppia apertura e blocco esagonale, adatto a tutti i tipi di spine industriali.
- c. Può contenere da 2 a 4 lucchetti con diametro dell'arco inferiore a 7 mm per bloccarli contemporaneamente.

Part Code	Description
BD-D41	51mm(height)*51mm(thickness)*89mm(width), for cable diameter 13mm
BD-D42	65mm(height)*65mm(thickness)*118mm(width), for cable diameter 20mm

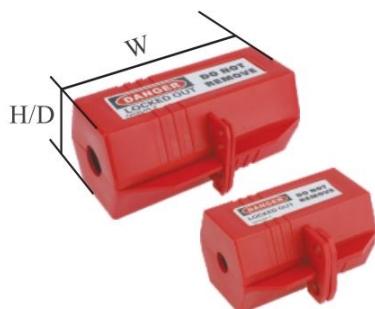

BLOCCAGGIO VALVOLA A SFERA REGOLABILE

- a. Realizzato in polipropilene PP.
- b. Dimensioni applicate:
BD-F01 blocca tubi da 13 mm (1/2") a 64 mm (2 1/2") di diametro
- c. Lucchetto con grillo bloccato diametro massimo: 9 mm
- d. Colore: rosso, gli altri colori devono essere personalizzati.

Part Code	Description
BD-F01	Suitable for 13mm(1/2")to 64mm(2 1/2")pipes



BLOCCO VALVOLA A SARACINESCA REGOLABILE

- a. Realizzato in polipropilene PP.
- b. L'intervallo di blocco può essere regolato. Bloccare il volantino valvola diametro 25mm-165mm(1"-6.5").
- c. Chiuso con un lucchetto, diametro massimo dell'arco di chiusura 7 mm.
- d. Colore: rosso, altri colori devono essere personalizzati. È disponibile il tagout .

Part Code	Description
BD-F16	Valve rod diameter 25mm-165mm(1"-6.5")



BLOCCO DEL CAVO REGOLABILE

- e. Realizzato in plastica tecnica PC resistente agli urti, personalizzabile in altri colori.
- f. Cavo da 1,8 metri utilizzato, lo strato esterno di il cavo è realizzato in P VC anti-UV (diametro 6 mm) e può essere personalizzato con diverse lunghezze e colori.
- g. Resiste a temperature estreme da -46°C a 149°C.
- h. Chiuso con 4 lucchetti, il diametro dell'arco del lucchetto è inferiore a 7 mm.

Part Code	Description
BD-L11-1	Cable specification:4mm*1.8m
BD-L11-2	Cable specification:6mm*1.8m



BD-L11

Produttore: Shanghaimuxinmuyeyouxiangongsi

Indirizzo: Baoshanqu Shuangchenglu 803long 11hao 1602A-1609shi
Shanghai

Importato in AUS: SIHAO PTY LTD, 1 ROKEVA STREETEASTWOOD
NSW 2122 Australia

Importato negli USA: Sanven Technology Ltd.

Suite 250 , 9166 Anaheim Place, Rancho Cucamonga, CA 91730



SHUNSHUN GmbH

Römeräcker 9 Z2021,76351

Linkenheim-Hochstetten, Germany

euvertreter@gmail.com

+49 1727041930



Pooledas Group Ltd

Unit 5 Albert Edward House, The

Pavilions Preston, United Kingdom

pooledas123@gmail.com

Tel: 01772418127

Made in China

VEVOR[®]

TOUGH TOOLS, HALF PRICE

Tecnico Supporto e certificato di garanzia elettronica

www.vevor.com/support