

# **VEVOR<sup>®</sup>**

## **TOUGH TOOLS, HALF PRICE**

Technical Support and E-Warranty Certificate

[www.vevor.com/support](http://www.vevor.com/support)

# **STEEL WIRE SHELF USER MANUAL**

We continue to be committed to provide you tools with competitive price.

"Save Half", "Half Price" or any other similar expressions used by us only represents an estimate of savings you might benefit from buying certain tools with us compared to the major top brands and does not necessarily mean to cover all categories of tools offered by us. You are kindly reminded to verify carefully when you are placing an order with us if you are actually saving half in comparison with the top major brands.

# VEVOR®

TOUGH TOOLS, HALF PRICE

## STEEL WIRE SHELF

**MODEL:** 6361QQUOV0 / 848E5KW7V0 / 040L9EDJV0 / 048EEK17V0  
448JA98TV0 / 8483M37BV0 / 040OGMXUV0

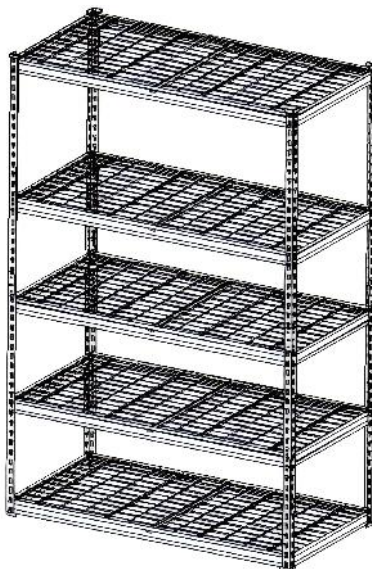



### NEED HELP? CONTACT US!

Have product questions? Need technical support? Please feel free to contact us:

**Technical Support and E-Warranty Certificate**  
**[www.vevor.com/support](http://www.vevor.com/support)**

This is the original instruction, please read all manual instructions carefully before operating. VEVOR reserves a clear interpretation of our user manual. The appearance of the product shall be subject to the product you received. Please forgive us that we won't inform you again if there are any technology or software updates on our product.

## IMPORTANT SAFETY INSTRUCTIONS

	Warning - To reduce the risk of injury, user must read instructions manual carefully.
	This symbol, placed before a safety comment, indicates a kind of precaution, warning, or danger. Ignoring this warning may lead to an accident. To reduce the risk of injury, fire, or electrocution, please always follow the recommendations shown below.
	Warning- Be sure to wear gloves when using this product.

### **WARNING!**

- 1) Keep this manual for the safety warnings and precautions. The manual offers important information on how to assemble, use and maintain this product.
- 2) Please handle metal edges carefully.
- 3) DO NOT stand on this product or use it as a ladder.
- 4) DO NOT alter this product in any manner that is not intended, as this may cause product damage or personal injury.
- 5) Always assemble on an even surface.
- 6) The maximum loaded weight for each shelf is no more than 180 kg, evenly distributed.
- 7) Store the heaviest items on lower shelves.
- 8) Attach the unit to the wall if filling to capacity (fittings not included).

## **ASSEMBLY PRECAUTIONS**

1. Please assemble the product in strict accordance with the instructions. Incorrect assembly could be hazardous.
2. Please wear safety goggles and work gloves properly during assembly.
3. Do not try to assemble the product when feeling tired or when under the influence of alcohol, drugs or medication.
4. Load-bearing capacity and other product parameters are applied to the properly and completely assembled product only.
5. A hammer and a pair of gloves may also be used, provided a cloth or wood block is placed between the hammer head and the parts.

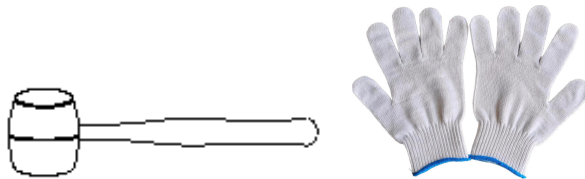

## **USE PRECAUTIONS**

1. This product is not a toy. Do not allow children to play with or get access to this item.
2. Check carefully before use. Do not use it if parts get loosened or damaged.
4. Use on flat, level, and hard surfaces only.
5. Do not exceed the listed load-bearing capacity. Tighten all the knobs securely before placing weights on it. Be aware of the dynamic load-bearing capacity! Sudden load changes may temporarily cause excessive load, resulting in product failure.

## **SAVE THESE INSTRUCTIONS**

## PRODUCT PARAMETERS





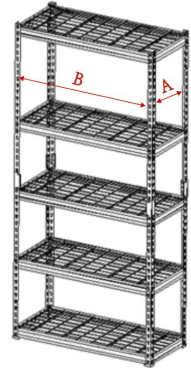







	1	2	3	4
Model	6361QQUOV0	848E5KW7V0	040L9EDJV0	048EEK17V0
Product size / inch	16×36×72	18×48×72	20×40×60	20×48×72
Dimension : A × B / inch	33.5 × 13.5	15.5 × 45.5	17.5 × 37.5	17.5 × 45.5
Color	Black	Black	Black	Black
Layers	5	5	4	5
Total load limit	2000lbs	2500lbs	2400lbs	3000lbs
load limit for each layer	400lbs	500lbs	600lbs	600lbs

	5	6	7
Model	448JA98TV0	8483M37BV0	040OGMXUV0
Product size	24×48×72inch	18×48×72inch	20×40×60inch
Dimension: A × B / inch	21.5 × 45.5	15.5 × 45.5	17.5 × 37.5
Color	Black	Orange	Orange
Layers	5	5	4
Total load limit	3000lbs	2500lbs	2400lbs
load limit for each layer	600lbs	500lbs	600lbs



**Note:** Heavy objects should be evenly distributed on the shelf to avoid deformation due to concentrated load. The maximum weight of a single heavy object should not exceed 30 kg.

## PART LIST

Part	Description	Picture	Part Qty			
			6361Q QUOV0	848E5 KW7V0	040L9 EDJV0	048EE K17V0
			16×36× 72inch	18×48× 72inch	20×40× 60inch	20×48× 72inch
A	Steel mesh		5	5	4	5
B	Upright post		8	8	8	8
C	Top shelf short beam		10	10	8	10
D	Top shelf long beam		10	10	8	10
E	Fixings		4	4	4	4
F	Post cap		16	16	16	16
G	Reinforcer		5	5	4	5
H	Hook		4	4	4	4
I	Gloves		1 pair	1 pair	1 pair	1 pair
J	Anti-tip accessories		2 sets	2 sets	2 sets	2 sets
K	Connector		2	2	2	2
L	Hammer		1	1	1	1
Height of separated shelves			36inch	36inch	30inch	36inch

Part	Description	Picture	Part Qty		
			448JA 98TV0	8483M 37BV0	040OG MXUV0
			24×48× 72inch	18×48× 72inch	20×40× 60inch
A	Steel mesh		5	5	4
B	Upright post		8	8	8
C	Top shelf short beam		10	10	8
D	Top shelf long beam		10	10	8
E	Fixings		4	4	4
F	Post cap		16	16	16
G	Reinforcer		5	5	4
H	Hook		4	4	4
I	Gloves		1 pair	1 pair	1 pair
J	Anti-tip accessories		2 sets	2 sets	2 sets
K	Connector		2	2	2
L	Hammer		1	1	1
Height of separated shelves			36inch	36inch	30inch

Top shelf beam rivets has a design that allowing Steel mesh to sit.

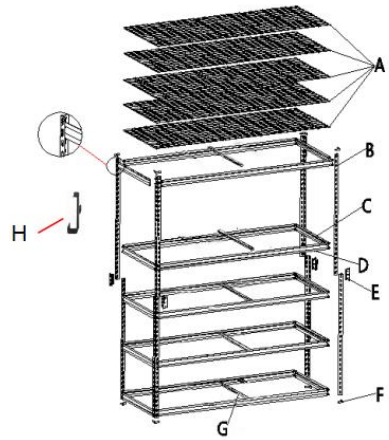

**Attention:**

For additional information regarding the parts listed below, please refer to the Assembly Diagram in this manual. Unwrap and separate all parts in a clear work area.

**ASSEMBLY STEP**

**Step 1: Post Cap Assembly**

1. Slide each post (B) into post cap (F) as shown.
2. Repeat for all 4 upright posts.

Attention: Post caps are for upright feet only.

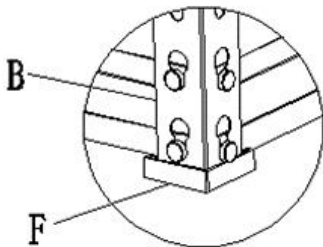



## Step 2: Short and Long Beam Assembly

1. Align short beams (C) & top shelf long beams (D) to aligned notches between four upright posts (B).
2. Once in position, tap firmly using a rubber mallet.
3. Repeat process for opposite side, ensuring both ends are set at the same height.

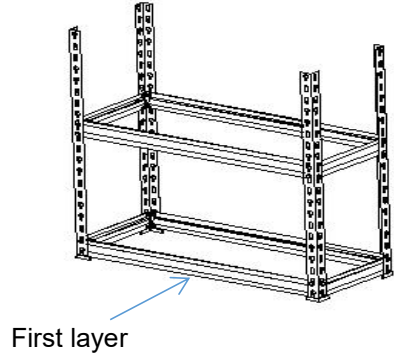
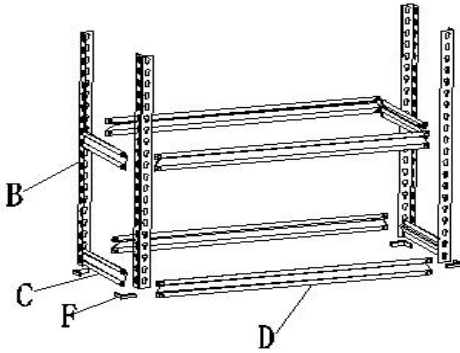

Note:

- Keep the first layer off the ground within 1 to 3 hole heights to prevent the columns from deforming and collapsing due to excessive height.
- Ensure that the height of each level is as uniform as possible.

## Step 3: Fixings Assembly

1. Fix fixings (E) at the top of the upright post (B), and tap down to the end.

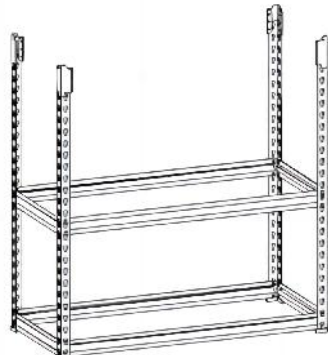
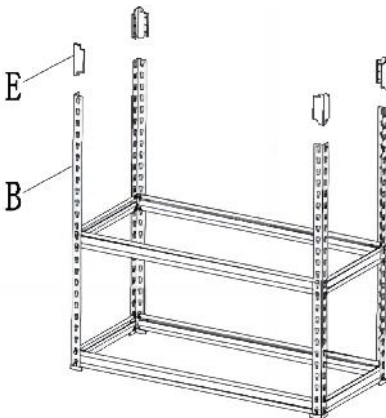

#### Step 4: Install The Upright Post

1. The bottom of the upright post(B) is secured to each fixing(E), and tap down to the end.

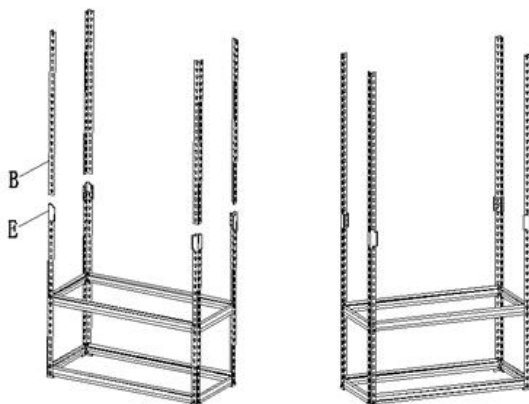

**Step 5: Install the third, fourth and fifth top shelf long beam(D) and short beam(C); the installation method is the same as Step 2.**



## Step 6: Install the Reinforcer.

1. install part G on each part D.

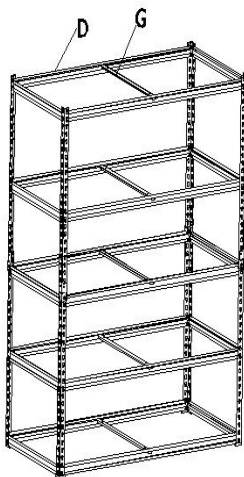

## Step 7: Steel Mesh Top Shelf Assembly

1. Insert steel mesh top shelf (A) onto the top shelf supports.
2. Ensure it sits flush with the top of the unit frame.

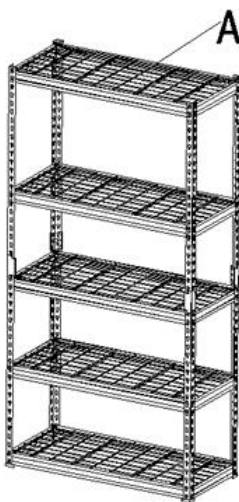

## Step 8: Install The Top Glue Foot

1. Slide each post (B) into post cap (F) as shown.
2. Repeat for all 4 upright posts.
3. Assembly is now complete, and your unit is ready for use.
4. Anti-tip accessories (Part J) can be used to secure the shelf to the wall to prevent tipping.

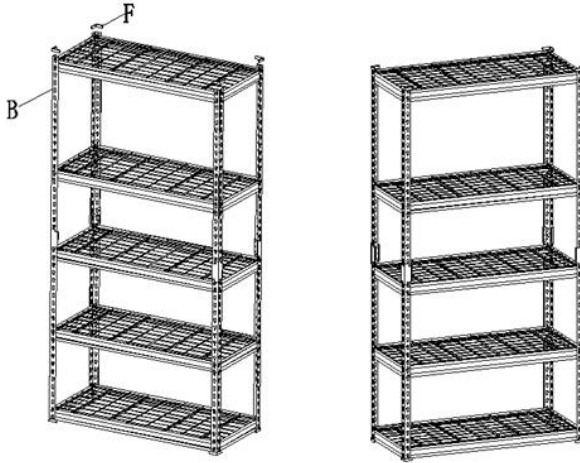

## Additional Functionality

1. This product can be separated into two shelves. You can find the height of each shelf in the table of part lists.

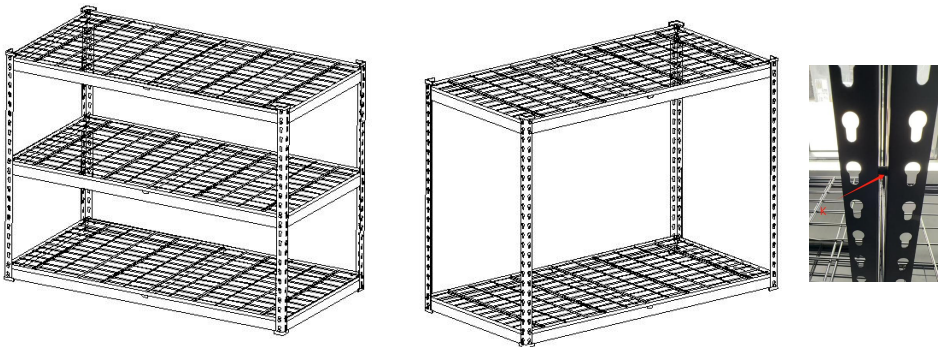

Note: When split for use, the two shelves can be connected with part K as shown.

## 2. Conversion of Steel Mesh to Side Panels:

Attach the steel mesh shelf to the side of the shelving unit using two(Part H).

### 2.1 Suitable Usage:

This setup is ideal for storing commonly used, lightweight tools such as tape measures, pliers, and hammers.

### 2.2 Safety Precautions:

Do not use excessively long hooks to hang large, heavy items to prevent potential injuries from hooks or falling objects.

Avoid hanging heavy items that could cause the shelving to tip over.

### 2.3 Hook Allocation:

- Each side panel should be supported by two hooks. A total of four hooks are provided, suitable for two side panels.
- Due to alignment issues with the holes, do not use all four hooks to hang a single side panel to ensure the panel can be installed properly.



Hook

**Manufacturer:** Shanghaimuxinmuyeyouxiangongsi

**Address:** Shuangchenglu 803nong11hao1602A-1609shi, baoshanqu, shanghai 200000 CN.

**Imported to AUS:** SIHAO PTY LTD, 1 ROKEVA STREETEASTWOOD NSW 2122 Australia

**Imported to USA:** Sanven Technology Ltd., Suite 250, 9166 Anaheim Place, Rancho Cucamonga, CA 91730

<b>EC</b>	<b>REP</b>
-----------	------------

E-CrossStu GmbH  
Mainzer Landstr.69, 60329 Frankfurt am Main.

<b>UK</b>	<b>REP</b>
-----------	------------

YH CONSULTING LIMITED.  
C/O YH Consulting Limited Office 147, Centurion House,  
London Road, Staines-upon-Thames, Surrey, TW18 4AX



**VEVOR<sup>®</sup>**

**TOUGH TOOLS, HALF PRICE**

**Technical Support and E-Warranty Certificate**

**[www.vevor.com/support](http://www.vevor.com/support)**



# **VEVOR<sup>®</sup>**

## **TOUGH TOOLS, HALF PRICE**

Assistance technique et certificat de garantie électronique

[www.vevor.com/support](http://www.vevor.com/support)

# **ÉTAGÈRE EN FIL D'ACIER**

## **MANUEL D' UTILISATION**

We continue to be committed to provide you tools with competitive price.

"Save Half", "Half Price" or any other similar expressions used by us only represents an estimate of savings you might benefit from buying certain tools with us compared to the major top brands and does not necessarily mean to cover all categories of tools offered by us. You are kindly reminded to verify carefully when you are placing an order with us if you are actually saving half in comparison with the top major brands.

# VEVOR®

TOUGH TOOLS, HALF PRICE

## STEEL WIRE SHELF

**MODÈLE** : 6361QQUOV0 / 848E5KW7V0 / 040L9EDJV0 / 048EEK17V0  
448JA98TV0 / 8483M37BV0 / 040OGMXUV0

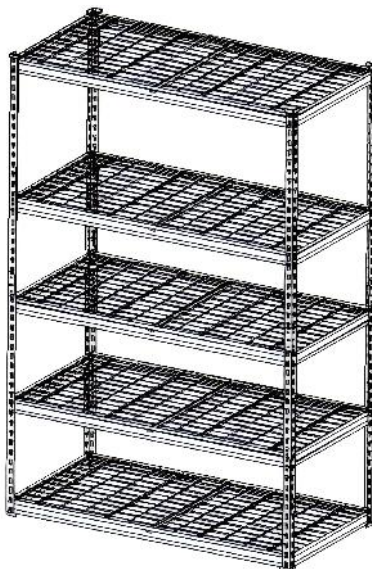



### NEED HELP? CONTACT US!

Have product questions? Need technical support? Please feel free to contact us:

**Technical Support and E-Warranty Certificate**  
**[www.vevor.com/support](http://www.vevor.com/support)**

This is the original instruction, please read all manual instructions carefully before operating. VEVOR reserves a clear interpretation of our user manual. The appearance of the product shall be subject to the product you received. Please forgive us that we won't inform you again if there are any technology or software updates on our product.

## IMPORTANT SAFETY INSTRUCTIONS

	Avertissement - Pour réduire le risque de blessure, l'utilisateur doit lire attentivement le manuel d'instructions.
	Ce symbole, placé avant un commentaire de sécurité, indique un type de précaution, d'avertissement ou de danger. Ignorer cet avertissement peut entraîner un accident. Pour réduire le risque de blessure, d'incendie ou d'électrocution, veuillez toujours suivre les recommandations ci-dessous.
	Avertissement – Assurez-vous de porter des gants lorsque vous utilisez ce produit.

### **WARNING!**

- 9) Conservez ce manuel pour connaître les avertissements et précautions de sécurité. Le manuel fournit des informations importantes sur la manière d'assembler, d'utiliser et d'entretenir ce produit.
- 10) Veuillez manipuler les bords métalliques avec précaution.
- 11) NE PAS monter sur ce produit ni l'utiliser comme échelle.
- 12) NE MODIFIEZ PAS ce produit d'une manière non prévue, car cela pourrait endommager le produit ou provoquer des blessures corporelles.
- 13) Assemblez toujours sur une surface plane.
- 14) Le poids maximal chargé pour chaque étagère ne dépasse pas 180 kg, uniformément réparti.
- 15) Rangez les articles les plus lourds sur les étagères inférieures.
- 16) Fixez l'unité au mur si vous la remplissez à pleine capacité (raccords non inclus).

## **PRÉCAUTIONS D'ASSEMBLAGE**

3. Veuillez assembler le produit en respectant scrupuleusement les instructions. Un assemblage incorrect peut être dangereux.
4. Veuillez porter des lunettes de sécurité et des gants de travail correctement pendant l'assemblage.
3. N'essayez pas d'assembler le produit lorsque vous vous sentez fatigué ou sous l'influence de l'alcool, de drogues ou de médicaments.
4. La capacité de charge et les autres paramètres du produit s'appliquent uniquement au produit correctement et complètement assemblé.
5. Un marteau et une paire de gants peut également être utilisé, à condition qu'un chiffon ou un bloc de bois soit placé entre la tête du marteau et les pièces.

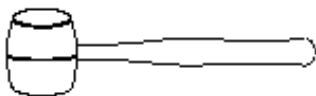

## **PRÉCAUTIONS D'EMPLOI**

1. Ce produit n'est pas un jouet. Ne laissez pas les enfants jouer avec cet article ou y accéder.
2. Vérifiez soigneusement avant utilisation. Ne l' utilisez pas si des pièces sont desserrées ou endommagées.
4. Utiliser uniquement sur des surfaces planes, nivelées et dures.
5. Ne dépassez pas la capacité de charge indiquée . Serrez fermement tous les boutons avant de placer des poids dessus . Soyez conscient de la capacité de charge dynamique ! Des changements de charge soudains peuvent temporairement provoquer une charge excessive, entraînant une défaillance du produit.

## **CONSERVEZ CES INSTRUCTIONS**

## PRODUCT PARAMETERS

	1	2	3	4
Modèle	6361QQUOV0	848E5KW7V0	040L9EDJV0	048EEK17V0
Taille du produit / pouce	16×36× 72	18 × 48 × 72	2 0 × 4 0 × 60	2 0 × 48 × 72
Dimension : Un × B / pouce	33,5 × 13. 5	15,5 × 45. 5	17,5 × 37. 5	17,5 × 45. 5
Couleur	Noir	Noir	Noir	Noir
Couches	5	5	4	5
Limite de charge totale	2000 lb	2 500 livres	2 4 00 livres	3000 lb
limite de charge pour chaque couche	400 livres	5 00 livres	6 00 livres	6 00 livres



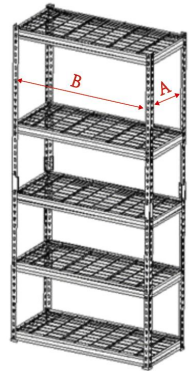





	5	6	7
Modèle	448JA98TV0	8483M37BV0	040OGMXUV0
Taille du produit	24 × 48 × 72 pouces	18 × 48 × 72 pouces	2 0 × 4 0 × 60 pouces
Dimension: Un × B / pouce	21,5 × 45. 5	15,5 × 45. 5	17,5 × 37. 5
Couleur	Noir	Orange	Orange
Couches	5	5	4
Limite de charge totale	3 000 lb	2 500 livres	2 4 00 livres
limite de charge pour chaque	6 00 livres	5 00 livres	6 00 livres















couche			
--------	--	--	--

**Remarque :** les objets lourds doivent être répartis uniformément sur l'étagère pour éviter toute déformation due à une charge concentrée. Le poids maximal d'un seul objet lourd ne doit pas dépasser 30 kg.

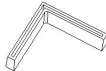
## PART LIST

Partie	Description	Image	Quantité de pièces			
			6361Q QUOV0	848E5 KW7V0	040L9 EDJV0	048EE K17V0
			16×36× 72 pouces	18 × 48 × 72 pouces	20 × 40 × 60 pouces	20 × 48 × 72 pouces
UN	Maille en acier		5	5	4	5
B	Poteau vertical		8	8	8	8
C	Poutre courte de l'étagère supérieure		10	10	8	10
D	Étagère supérieure à poutre longue		10	10	8	10
E	Fixations		4	4	4	4
F	Capuchon de poteau		16	16	16	16
G	Renforteur		5	5	4	5
H	Crochet		4	4	4	4

je	Gants		1 paire	1 paire	1 paire	1 paire
J	Accessoires anti-basculement		2 ensembles	2 ensembles	2 ensembles	2 ensembles
K	Connecteur		2	2	2	2
L	Marteau		1	1	1	1
Hauteur des étagères séparées			36 pouces	36 pouces	30 pouces	36 pouces

Partie	Description	Image	Quantité de pièces		
			448JA 98TV0	8483M 37BV0	040OG MXUV0
			24 × 48 × 72 pouces	18 × 48 × 72 pouces	20 × 40 × 60 pouces
UN	Maille en acier		5	5	4
B	Poteau vertical		8	8	8
C	Poutre courte de l'étagère supérieure		10	10	8
D	Étagère supérieure à poutre longue		10	10	8
E	Fixations		4	4	4
F	Capuchon de poteau		16	16	16
G	Renforteur		5	5	4
H	Crochet		4	4	4
je	Gants		1 paire	1 paire	1 paire
J	Accessoires anti-basculement		2 ensembles	2 ensembles	2 ensembles
K	Connecteur		2	2	2
L	Marteau		1	1	1
Hauteur des étagères séparées			36 pouces	36 pouces	30 pouces



Les rivets de la poutre de l'étagère supérieure sont dotés d'une conception qui permet au treillis en acier de s'asseoir .

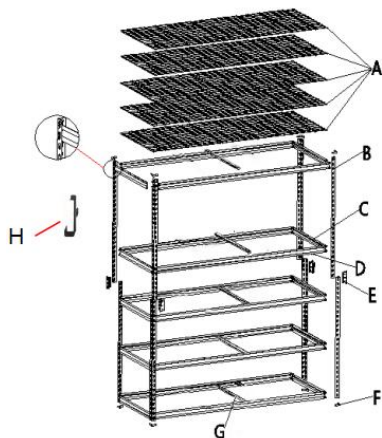

### Attention:

Pour plus d'informations sur les pièces répertoriées ci-dessous, reportez-vous au schéma d'assemblage de ce manuel. Déballez et séparez toutes les pièces dans une zone de travail dégagée.

## ASSEMBLY STEP

### Étape 1 : Assemblage du capuchon de poteau

1. Faites glisser chaque poteau (B) dans le capuchon de poteau (F) comme indiqué.

2. Répétez l'opération pour les 4 poteaux verticaux.

Attention : les capuchons de poteau sont destinés uniquement aux pieds verticaux.

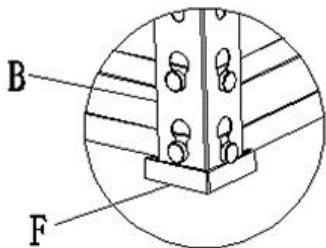

## Étape 2 : Assemblage des poutres courtes et longues

1. Alignez les poutres courtes ( C ) et les poutres longues de l'étagère supérieure ( D ) sur les encoches alignées entre les quatre poteaux verticaux ( B ).
2. Une fois en position, tapez fermement à l'aide d'un maillet en caoutchouc.
3. Répétez le processus pour le côté opposé, en vous assurant que les deux extrémités sont placés à la même hauteur.

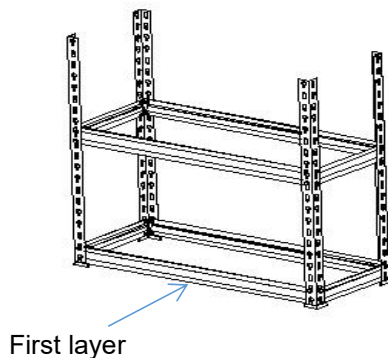
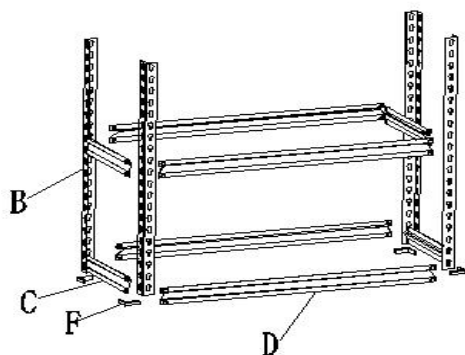

Note:

- Maintenez la première couche hors du sol dans une hauteur de 1 à 3 trous pour éviter que les colonnes ne se déforment et ne s'effondrent en raison d'une hauteur excessive.
- Assurez-vous que la hauteur de chaque niveau est aussi uniforme que possible.

## Étape 3 : Assemblage des fixations

1. Fixez les fixations (E) en haut du poteau vertical (B) et appuyez jusqu'au bout.

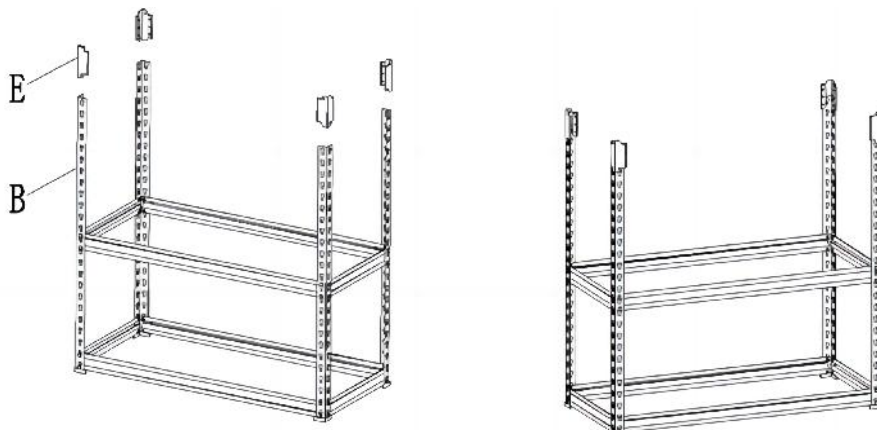

#### Étape 4 : Installer le poteau vertical

1. Le bas du poteau vertical (B) est fixé à chaque fixation (E) et enfoncé jusqu'au bout.

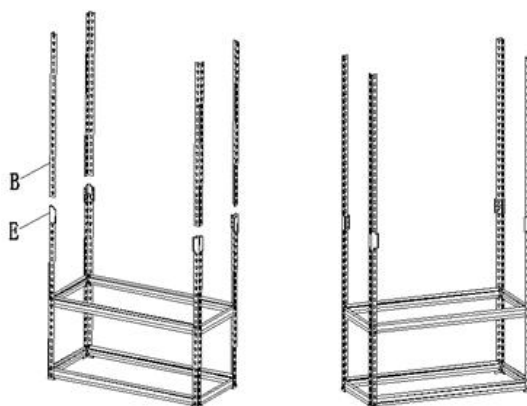

**Étape 5 : Installez la troisième, la quatrième et la cinquième poutre longue (D) et la poutre courte (C) de l'étagère supérieure ; la méthode d'installation est la même que celle de l'étape 2.**



## Étape 6 : Installez le renfort.

1. installer la pièce G sur chaque pièce D.

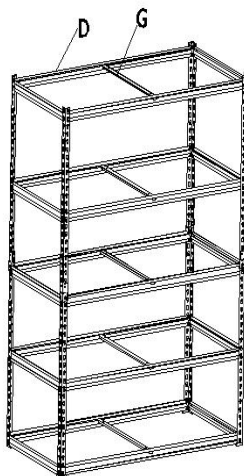

## Étape 7 : Assemblage de l'étagère supérieure en treillis d'acier

1. Insérez l'étagère supérieure en maille d'acier (A) sur les supports d'étagère supérieure.

2. Assurez-vous qu'il est bien aligné avec le haut du cadre de l'unité.

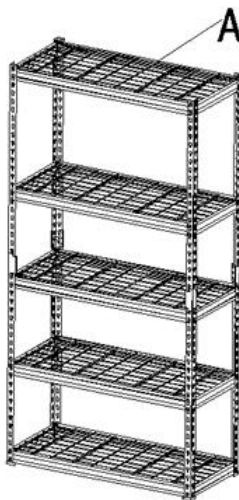

## Étape 8 : Installez le pied de colle supérieur

1. Faites glisser chaque poteau (B) dans le capuchon de poteau (F) comme indiqué.
2. Répétez l'opération pour les 4 poteaux verticaux.
3. L'assemblage est maintenant terminé et votre appareil est prêt à être utilisé.
4. Des accessoires anti-basculement (pièce J) peuvent être utilisés pour fixer l'étagère au mur afin d'éviter tout basculement.

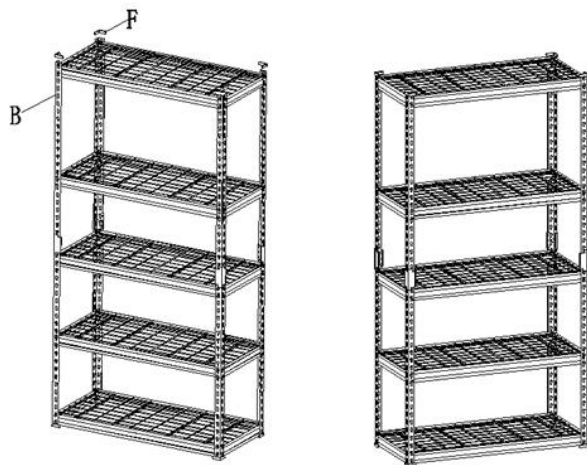

## Additional Functionality

3. Ce produit peut être séparé en deux étagères . Vous pouvez trouver la hauteur de chaque étagère dans le tableau des listes de pièces .

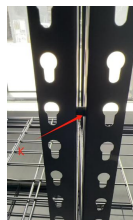
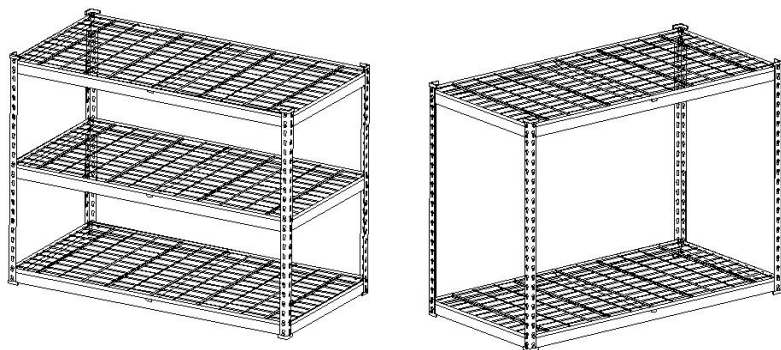

Note: Lorsqu'elles sont séparées pour l'utilisation, les deux étagères peuvent être reliées à la partie K comme montré .

#### **4. Conversion de treillis en acier en panneaux latéraux :**

Fixez l'étagère en treillis d'acier sur le côté de l'étagère à l'aide de deux (partie H).

##### **2.1 Utilisation appropriée :**

Cette configuration est idéale pour ranger des outils légers et couramment utilisés tels que des mètres rubans, des pinces et des marteaux.

##### **2.2 Précautions de sécurité :**

N'utilisez pas de crochets trop longs pour suspendre des objets volumineux et lourds afin d'éviter d'éventuelles blessures causées par les crochets ou les objets qui tombent.

Évitez de suspendre des objets lourds qui pourraient faire basculer l'étagère.

##### **2.3 Affectation des crochets :**

- Chaque panneau latéral doit être soutenu par deux crochets. Au total, quatre crochets sont fournis, adaptés à deux panneaux latéraux.
- En raison de problèmes d'alignement des trous, n'utilisez pas les quatre crochets pour accrocher un seul panneau latéral afin de garantir que le panneau puisse être installé correctement.

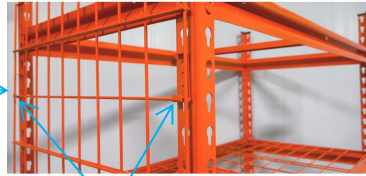

Hook

**Fabricant :** Shanghaimuxinmuyeyouxiangongsi

**Adresse :** Shuangchenglu 803nong11hao1602A-1609shi, baoshanqu, Shanghai 200000 CN.

**Importé en Australie :** SIHAO PTY LTD, 1 ROKEVA STREET, ASTWOOD NSW 2122 Australie

**Importé aux États-Unis :** Sanven Technology Ltd., Suite 250, 9166 Anaheim Place, Rancho Cucamonga, CA 91730

<b>EC</b>	<b>REP</b>
-----------	------------

E-CrossStu GmbH  
Mainzer Landstr.69, 60329 Frankfurt am Main.

<b>UK</b>	<b>REP</b>
-----------	------------

YH CONSULTING LIMITED.  
C/O YH Consulting Limited Office 147, Centurion House,  
London Road, Staines-upon-Thames, Surrey, TW18 4AX







**VEVOR<sup>®</sup>**

**TOUGH TOOLS, HALF PRICE**

**Technique Certificat d'assistance et de garantie électronique**

**[www.vevor.com/support](http://www.vevor.com/support)**

# **VEVOR<sup>®</sup>**

## **TOUGH TOOLS, HALF PRICE**

Technischer Support und E-Garantie-Zertifikat

[www.vevor.com/support](http://www.vevor.com/support)

# **STAHLDRAHTREGAL BENUTZERHANDBUCH**

We continue to be committed to provide you tools with competitive price.

"Save Half", "Half Price" or any other similar expressions used by us only represents an estimate of savings you might benefit from buying certain tools with us compared to the major top brands and does not necessarily mean to cover all categories of tools offered by us. You are kindly reminded to verify carefully when you are placing an order with us if you are actually saving half in comparison with the top major brands.

# VEVOR®

TOUGH TOOLS, HALF PRICE

## STEEL WIRE SHELF

**MODELL:** 6361QQUOV0 / 848E5KW7V0 / 040L9EDJV0 / 048EEK17V0  
448JA98TV0 / 8483M37BV0 / 040OGMXUV0

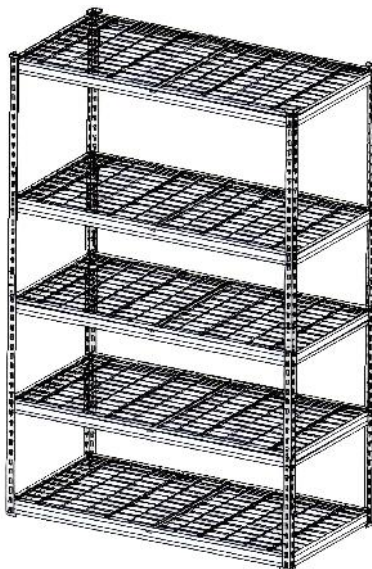



### NEED HELP? CONTACT US!

Have product questions? Need technical support? Please feel free to contact us:

**Technical Support and E-Warranty Certificate**  
**[www.vevor.com/support](http://www.vevor.com/support)**

This is the original instruction, please read all manual instructions carefully before operating. VEVOR reserves a clear interpretation of our user manual. The appearance of the product shall be subject to the product you received. Please forgive us that we won't inform you again if there are any technology or software updates on our product.

## IMPORTANT SAFETY INSTRUCTIONS

	Warnung – Um das Verletzungsrisiko zu verringern, muss der Benutzer die Bedienungsanleitung sorgfältig lesen.
	Dieses Symbol vor einem Sicherheitshinweis weist auf eine Vorsichtsmaßnahme, Warnung oder Gefahr hin. Das Ignorieren dieser Warnung kann zu einem Unfall führen. Um das Risiko von Verletzungen, Bränden oder Stromschlägen zu verringern, befolgen Sie bitte immer die unten aufgeführten Empfehlungen .
	Achtung: Tragen Sie bei der Verwendung dieses Produkts unbedingt Handschuhe.

### **WARNING!**

- 17) Bewahren Sie dieses Handbuch wegen der Sicherheitswarnungen und Vorsichtsmaßnahmen auf. Das Handbuch enthält wichtige Informationen zur Montage, Verwendung und Wartung dieses Produkts.
- 18) Bitte gehen Sie vorsichtig mit Metallkanten um.
- 19) Stellen Sie sich NICHT auf dieses Produkt und verwenden Sie es NICHT als Leiter.
- 20) Verändern Sie das Produkt NICHT in einer Weise, die nicht dafür vorgesehen ist, da dies zu Produktschäden oder Verletzungen führen kann.
- 21) Immer auf einer ebenen Fläche zusammenbauen.
- 22) Die maximale Belastung jedes Regalbodens beträgt bei gleichmäßiger Verteilung maximal 180 kg.
- 23) Lagern Sie die schwersten Gegenstände auf den unteren Regalen.
- 24) Befestigen Sie das Gerät an der Wand, wenn Sie es bis zum Rand füllen (Befestigungselemente nicht im Lieferumfang enthalten).

## **VORSICHTSMASSNAHMEN BEI DER MONTAGE**

5. Bitte montieren Sie das Produkt streng gemäß der Anleitung. Eine falsche Montage kann gefährlich sein.
6. Bitte tragen Sie während der Montage unbedingt eine Schutzbrille und Arbeitshandschuhe.
3. Versuchen Sie nicht, das Produkt zusammenzubauen, wenn Sie müde sind oder unter dem Einfluss von Alkohol, Drogen oder Medikamenten stehen.
4. Tragfähigkeit und andere Produktparameter gelten nur für das ordnungsgemäß und vollständig montierte Produkt.
5. Ein Hammer und ein Paar Handschuhe kann ebenfalls verwendet werden, sofern zwischen Hammerkopf und Teilen ein Tuch oder Holzblock platziert wird.

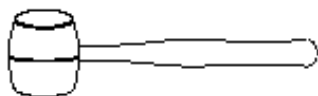

## **VORSICHTSMASSNAHMEN BEIM GEBRAUCH**

1. Dieses Produkt ist kein Spielzeug. Erlauben Sie Kindern nicht, mit diesem Artikel zu spielen oder darauf zuzugreifen.
2. Vor Gebrauch sorgfältig prüfen. Nicht verwenden, wenn Teile sich gelöst oder beschädigt haben.
4. Nur auf flachen, ebenen und harten Oberflächen verwenden.
5. Überschreiten Sie nicht die angegebene Tragfähigkeit . Ziehen Sie alle Knöpfe fest an, bevor Sie Gewichte darauf legen . Beachten Sie die dynamische Tragfähigkeit ! Plötzliche Laständerungen können vorübergehend zu einer Überlastung führen und zu einem Produktausfall führen.

## **BEWAHREN SIE DIESE ANWEISUNGEN AUF**

## PRODUCT PARAMETERS

Ar tikelnummer	1	2	3	4
Modell	6361QQUOV 0	848E5KW7V 0	040L9EDJV 0	048EEK17V 0
Produktgröße / Zoll	16×36× 72	18 ×48× 72	2 0 × 4 0 × 60	2 0 × 48 × 72
Dimension : A × B / Zoll	33. 5 × 13. 5	15. 5 × 45. 5	17, 5 × 37. 5	17, 5 × 45. 5
Farbe	Schwarz	Schwarz	Schwarz	Schwarz
Schichten	5	5	4	5
Gesamtbelastungsgrenze	2000 Pfund	2 5 00 Pfund	2 4 00 Pfund	3000 Pfund
Belastungsgrenze für jede Schicht	400 Pfund	5 00 Pfund	6 00 Pfund	6 00 Pfund

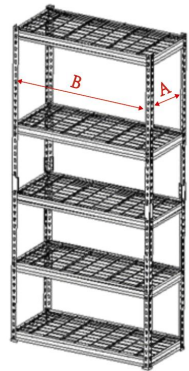

	5	6	7
Modell	448JA98TV0	8483M37BV0	040OGMXUV0
Produktgröße	24 × 48 × 72 Zoll	18 × 48 × 72 Zoll	2 0 × 4 0 × 60 Zoll
Dimension: A × B / Zoll	21. 5 × 45. 5	15. 5 × 45. 5	17, 5 × 37. 5
Farbe	Schwarz	Orange	Orange
Schichten	5	5	4
Gesamtbelastungsgrenze	3.000 Pfund	2 5 00 Pfund	2 4 00 Pfund
Belastungsgrenze für jede Schicht	6 00 Pfund	5 00 Pfund	6 00 Pfund













**Hinweis:** Schwere Gegenstände sollten gleichmäßig auf dem Regal verteilt werden, um Verformungen durch konzentrierte Last zu vermeiden. Das maximale Gewicht eines einzelnen schweren Gegenstandes sollte 30 kg nicht überschreiten.

## PART LIST

Teil	Beschreibung	Bild	Teilemenge			
			6361Q QUOV0	848E5 KW7V0	040L9 EDJV0	048EE K17V0
			16×36× 72 Zoll	18 ×48× 72 Zoll	20 × 40× 60 Zoll	20 × 48 × 72 Zoll
A	Stahlgeflecht		5	5	4	5
B	Aufrechter Pfosten		8	8	8	8
C	Oberes Regal, kurzer Balken		10	10	8	10
D	Oberes Regal mit langem Balken		10	10	8	10
E	Befestigungen		4	4	4	4
F	Pfostenkappe		16	16	16	16
G	Verstärker		5	5	4	5
H	Haken		4	4	4	4
ICH	Handschuhe		1 Paar	1 Paar	1 Paar	1 Paar

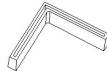
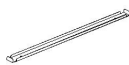
J	Kippschutz-Zubehör		2 Sätze	2 Sätze	2 Sätze	2 Sätze
K	Konnektor		2	2	2	2
M	Hammer		1	1	1	1
Höhe der getrennten Regale			36 Zoll	36 Zoll	30 Zoll	36 Zoll

Teil	Beschreibung	Bild	Teilemenge		
			448JA 98TV0	8483M 37BV0	040OG MXUV0
			24 × 48 × 72 Zoll	18 × 48 × 72 Zoll	20 × 40 × 60 Zoll
A	Stahlgeflecht		5	5	4
B	Aufrechter Pfosten		8	8	8
C	Oberes Regal, kurzer Balken		10	10	8
D	Oberes Regal mit langem Balken		10	10	8
E	Befestigungen		4	4	4
F	Pfostenkappe		16	16	16
G	Verstärker		5	5	4
H	Haken		4	4	4
ICH	Handschuhe		1 Paar	1 Paar	1 Paar
J	Kippschutz-Zubehör		2 Sätze	2 Sätze	2 Sätze
K	Konnektor		2	2	2
M	Hammer		1	1	1
Höhe der getrennten Regale			36 Zoll	36 Zoll	30 Zoll

Obere Regalträgernieten haben Ein Design , bei dem Stahlgeflecht sitzt .

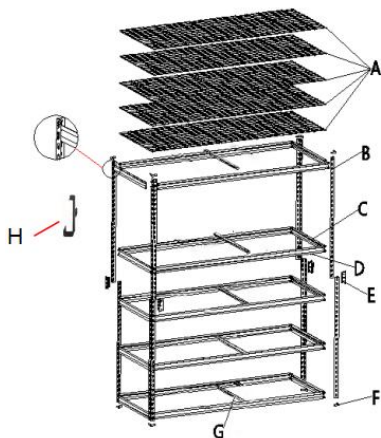

### Aufmerksamkeit:

Weitere Informationen zu den unten aufgeführten Teilen finden Sie im Montagediagramm in diesem Handbuch. Packen Sie alle Teile in einem freien Arbeitsbereich aus und trennen Sie sie voneinander.

## ASSEMBLY STEP

### Schritt 1: Montage der Pfostenkappen

1. Schieben Sie jeden Pfosten (B) wie gezeigt in die Pfostenkappe (F).
2. Wiederholen Sie dies für alle 4 aufrechten Pfosten.

Achtung: Pfostenkappen sind nur für Pfostenfüße geeignet.

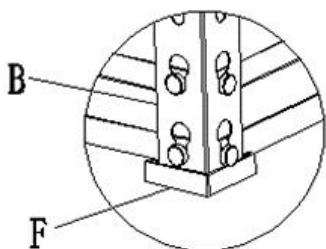

## Schritt 2: Zusammenbau des kurzen und langen Balkens

1. Richten Sie die kurzen Balken ( C ) und die langen Balken des oberen Regals ( D ) an den ausgerichteten Kerben zwischen den vier aufrechten Pfosten ( B ) aus.
2. Sobald es in Position ist, klopfen Sie mit einem Gummihammer fest darauf.
3. Wiederholen Sie den Vorgang für die gegenüberliegende Seite und stellen Sie sicher, dass beide Enden sind auf gleicher Höhe eingestellt.

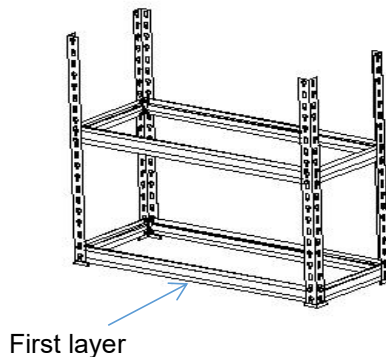
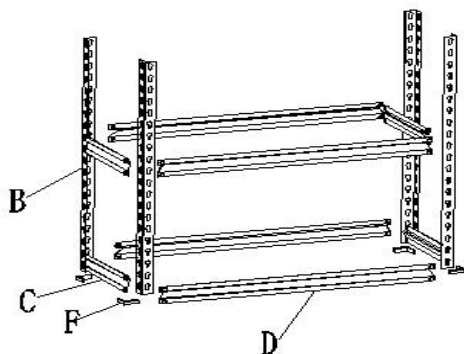

Notiz:

- Halten Sie die erste Schicht 1 bis 3 Lochhöhen über dem Boden, um zu verhindern, dass sich die Säulen aufgrund zu großer Höhe verformen und einstürzen.
- Achten Sie darauf, dass die Höhe der einzelnen Ebenen möglichst gleichmäßig ist.

## Schritt 3: Montage der Befestigungselemente

1. Befestigen Sie die Befestigungen ( E ) oben am aufrechten Pfosten ( B ) und klopfen Sie sie bis zum Ende fest.

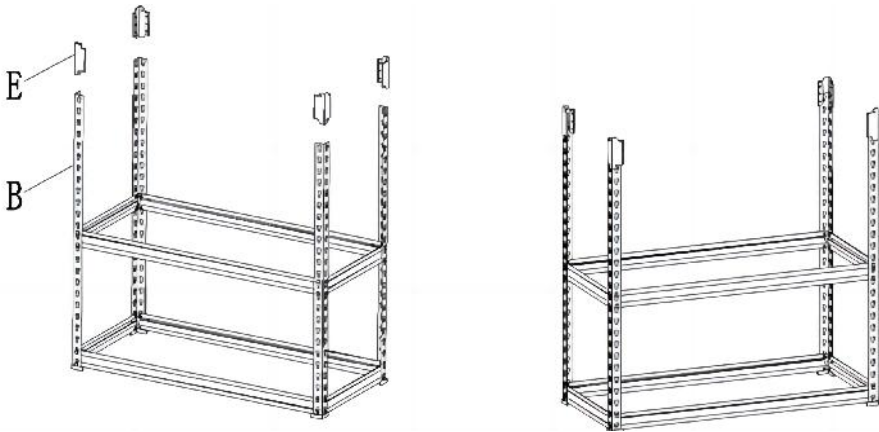

#### Schritt 4: Installieren Sie den aufrechten Pfosten

1. Die Unterseite des aufrechten Pfostens (B) wird an jeder Befestigung (E) befestigt und bis zum Ende festgeklopft.

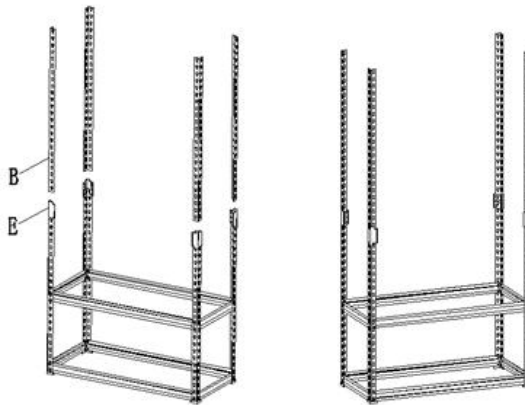

**Schritt 5: Installieren Sie den langen Balken (D) und den kurzen Balken (C) des dritten, vierten und fünften oberen Regals. Die Installationsmethode ist dieselbe wie in Schritt 2.**



## Schritt 6: Installieren Sie den Verstärker.

1. Installieren Sie Teil G auf jedem Teil D.

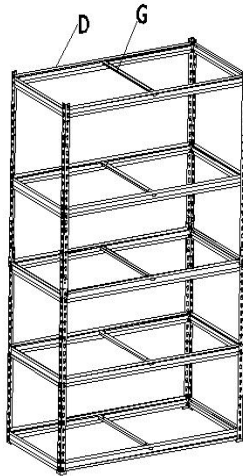

## Schritt 7: Montage des oberen Stahlgitterregals

1. Stecken Sie den oberen Regalboden (A) aus Stahlgitter auf die oberen Regalstützen.

2. Stellen Sie sicher, dass es bündig mit der Oberseite des Geräte Rahmens abschließt.

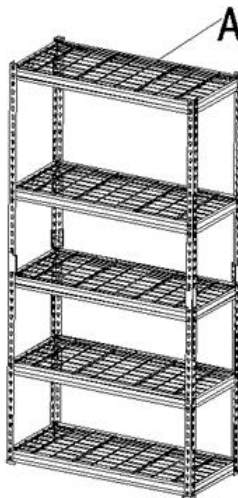



## Schritt 8: Installieren Sie den oberen Klebefuß

1. Schieben Sie jeden Pfosten (B) wie gezeigt in die Pfostenkappe (F).
2. Wiederholen Sie dies für alle 4 aufrechten Pfosten.
3. Die Montage ist nun abgeschlossen und Ihr Gerät ist einsatzbereit.
4. Mit Kippschutzzubehör (Teil J) kann das Regal an der Wand befestigt werden, um ein Umkippen zu verhindern.

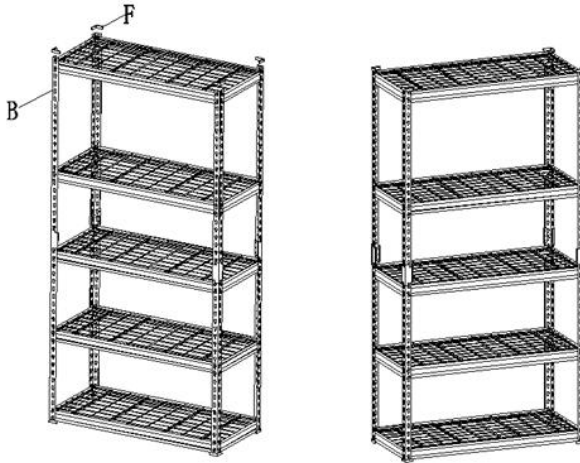

## Additional Functionality

5. Dieses Produkt kann in zwei Regale unterteilt werden. Die Höhe der einzelnen Regale finden Sie in der Tabelle der Stücklisten.

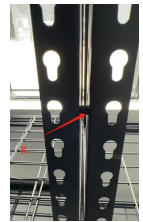
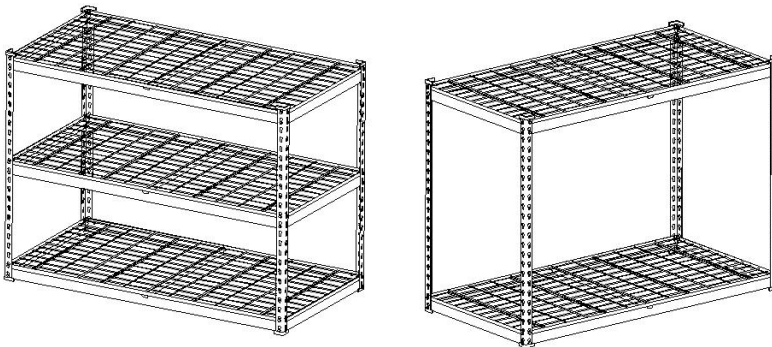

Notiz: Bei geteilter Nutzung können die beiden Regale mit Teil K verbunden werden. gezeigt.

## **6. Umbau von Stahlgeflecht zu Seitenwänden:**

Befestigen Sie den Stahlgitterboden mit zwei Stück (Teil H) an der Seite des Regals.

### **2.1 Geeignete Verwendung:**

Diese Anordnung eignet sich ideal für die Aufbewahrung häufig verwendeter, leichter Werkzeuge wie Maßbänder, Zangen und Hämmer.

### **2.2 Sicherheitsvorkehrungen:**

Verwenden Sie zum Aufhängen großer, schwerer Gegenstände keine übermäßig langen Haken, um mögliche Verletzungen durch Haken oder herabfallende Gegenstände zu vermeiden.

Hängen Sie keine schweren Gegenstände auf, die zum Umkippen der Regale führen könnten.

### **2.3 Hakenbelegung:**

- Jede Seitenwand sollte von zwei Haken getragen werden. Insgesamt sind vier Haken vorhanden, passend für zwei Seitenwände.
- Aufgrund von Ausrichtungsproblemen mit den Löchern sollten Sie nicht alle vier Haken zum Aufhängen einer einzelnen Seitenwand verwenden, um sicherzustellen, dass die Wand richtig installiert werden kann.

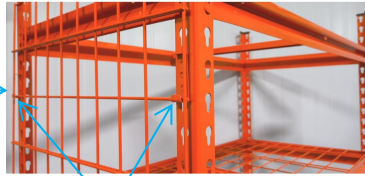

Hook

**Hersteller:** Shanghaimuxinmuyeyouxiangongsi

**Adresse:** Shuangchenglu 803nong11hao1602A-1609shi, baoshanqu, Shanghai 200000 CN.

**Nach AUS importiert:** SIHAO PTY LTD, 1 ROKEVA STREETEASTWOOD NSW 2122 Australien

**Importiert in die USA:** Sanven Technology Ltd., Suite 250, 9166 Anaheim Place, Rancho Cucamonga, CA 91730

EC	REP
----	-----

E-CrossStu GmbH  
Mainzer Landstr.69, 60329 Frankfurt am Main.

UK	REP
----	-----

YH CONSULTING LIMITED.  
C/O YH Consulting Limited Office 147, Centurion House,  
London Road, Staines-upon-Thames, Surrey, TW18 4AX





**VEVOR**<sup>®</sup>

**TOUGH TOOLS, HALF PRICE**

**Technisch Support und E-Garantie-Zertifikat**

**[www.vevor.com/support](http://www.vevor.com/support)**

# **VEVOR<sup>®</sup>**

## **TOUGH TOOLS, HALF PRICE**

Supporto tecnico e certificato di garanzia elettronica

[www.vevor.com/support](http://www.vevor.com/support)

# **RIPIANO IN FILO D'ACCIAIO**

## **MANUALE D' USO**

We continue to be committed to provide you tools with competitive price.

"Save Half", "Half Price" or any other similar expressions used by us only represents an estimate of savings you might benefit from buying certain tools with us compared to the major top brands and does not necessarily mean to cover all categories of tools offered by us. You are kindly reminded to verify carefully when you are placing an order with us if you are actually saving half in comparison with the top major brands.

# VEVOR<sup>®</sup>

TOUGH TOOLS, HALF PRICE

## STEEL WIRE SHELF

**MODELLO:** 6361QQUOV0 / 848E5KW7V0 / 040L9EDJV0 / 048EEK17V0  
448JA98TV0 / 8483M37BV0 / 040OGMXUV0

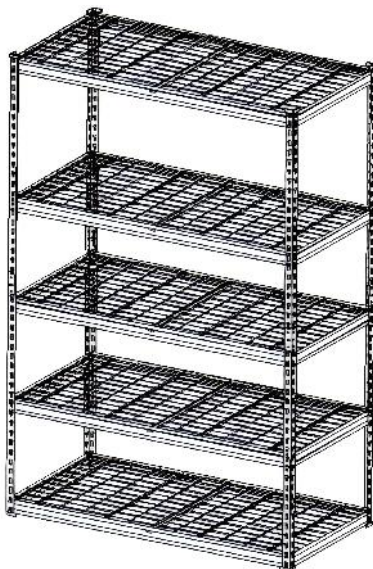

### NEED HELP? CONTACT US!



Have product questions? Need technical support? Please feel free to contact us:

**Technical Support and E-Warranty Certificate**  
**[www.vevor.com/support](http://www.vevor.com/support)**

This is the original instruction, please read all manual instructions carefully before operating. VEVOR reserves a clear interpretation of our user manual. The appearance of the product shall be subject to the product you received. Please forgive us that we won't inform you again if there are any technology or software updates on our product.



## IMPORTANT SAFETY INSTRUCTIONS

	Attenzione - Per ridurre il rischio di lesioni, l'utente deve leggere attentamente il manuale di istruzioni.
	Questo simbolo, posto prima di un commento sulla sicurezza, indica un tipo di precauzione, avviso o pericolo. Ignorare questo avviso può causare un incidente. Per ridurre il rischio di lesioni, incendi o folgorazione, seguire sempre le raccomandazioni mostrate di seguito.
	Attenzione: assicurarsi di indossare guanti quando si utilizza questo prodotto.

### **WARNING!**

- 25) Conservare questo manuale per le avvertenze e le precauzioni di sicurezza. Il manuale offre informazioni importanti su come assemblare, utilizzare e mantenere questo prodotto.
- 26) Maneggiare con cura i bordi metallici.
- 27) NON salire sul prodotto né utilizzarlo come scala.
- 28) NON modificare questo prodotto in alcun modo diverso da quello previsto, poiché ciò potrebbe danneggiare il prodotto o causare lesioni personali.
- 29) Eseguire sempre il montaggio su una superficie piana.
- 30) Il peso massimo caricabile su ogni ripiano non è superiore a 180 kg, uniformemente distribuito.
- 31) Conservare gli oggetti più pesanti sui ripiani più bassi.
- 32) Fissare l'unità alla parete se si desidera riempirla completamente (raccordi non inclusi).

## **PRECAUZIONI DI MONTAGGIO**

7. Si prega di assemblare il prodotto seguendo scrupolosamente le istruzioni. Un assemblaggio non corretto potrebbe essere pericoloso.
8. Si prega di indossare occhiali di sicurezza e guanti da lavoro durante il montaggio.
3. Non provare a montare il prodotto quando ci si sente stanchi o sotto l'effetto di alcol, droghe o farmaci.
4. La capacità di carico e gli altri parametri del prodotto si applicano solo al prodotto correttamente e completamente assemblato.
5. Un martello e un paio di guanti può essere utilizzato anche a condizione che tra la testa del martello e le parti venga inserito un panno o un blocco di legno.

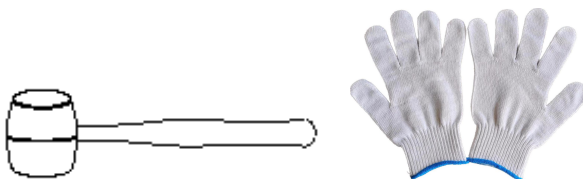

## **PRECAUZIONI D'USO**

1. Questo prodotto non è un giocattolo. Non permettere ai bambini di giocare con questo articolo o di accedervi.
2. Controllare attentamente prima dell'uso. Non utilizzarlo se le parti si allentano o si danneggiano.
4. Utilizzare solo su superfici piane, livellate e dure.
5. Non superare la capacità di carico indicata . Stringere saldamente tutte le manopole prima di posizionare i pesi . Siate consapevoli della capacità di carico dinamica ! Improvvisi cambiamenti di carico possono causare temporaneamente un carico eccessivo, con conseguente guasto del prodotto.

## **SALVA QUESTE ISTRUZIONI**

## PRODUCT PARAMETERS

	1	2	3	4
Modello	6361QQUOV0	848E5KW7V0	040L9EDJV0	048EEK17V0
Dimensioni del prodotto / pollice	Dimensioni: 16×36× 72	18 × 48 × 72	2 0 × 4 0 × 60	Dimensioni : 20 × 48 × 72
Dimensione : La × B / pollice	33. 5 × 13.5	15.5 × 45. 5	17.5 × 37. 5	17.5 × 45. 5
Colore	Nero	Nero	Nero	Nero
Strati	5	5	4	5
Limite di carico totale	2000 libbre	2 5 00 libbre	2 4 00 libbre	3000 libbre
limite di carico per ogni strato	400 libbre	5 00 libbre	6 00 libbre	6 00 libbre



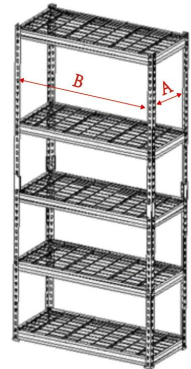







	5	6	7
Modello	448JA98TV0	8483M37BV0	040OGMXUV0
Dimensioni del prodotto / pollice	24 × 48 × 72	18 × 48 × 72	2 0 × 4 0 × 60
Dimensione: La × B / pollice	21.5 × 45. 5	15.5 × 45. 5	17.5 × 37. 5
Colore	Nero	Arancia	Arancia
Strati	5	5	4
Limite di carico totale	3.000 libbre	2 5 00 libbre	2 4 00 libbre
limite di carico per ogni strato	6 00 libbre	5 00 libbre	6 00 libbre













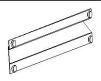

**Nota:** gli oggetti pesanti devono essere distribuiti uniformemente sullo scaffale per evitare deformazioni dovute al carico concentrato. Il peso

massimo di un singolo oggetto pesante non deve superare i 30 kg.

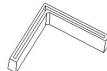
## PART LIST

Part e	Descrizione	Immagine	Parte Qtà			
			6361Q QUOV0	848E5 KW7V0	040L9 EDJV0	048EE K17V0
			Dimensioni : 16×36× 72 pollici	18 ×48× 72 pollici	2 0 × 4 0 × 60 pollici	2 0 × 48 × 72 pollici
UN	Maglia d'acciaio		5	5	4	5
B	palo verticale		8	8	8	8
C	Trave corta del ripiano superiore		10	10	8	10
D	Ripiano superiore trave lunga		10	10	8	10
E	Fissaggi		4	4	4	4
F	Tappo del palo		16	16	16	16
G	Rinforzante		5	5	4	5
H	Gancio		4	4	4	4
IO	Guanti		1 paio	1 paio	1 paio	1 paio
J	Accessori antiribaltamento		2 set	2 set	2 set	2 set

E	Connettore		2	2	2	2
L	Martello		1	1	1	1
Altezza dei ripiani separati			36 pollici	36 pollici	30 pollici	36 pollici

Parte	Descrizione	Immagine	Parte Qtà		
			448JA 98TV0	8483M 37BV0	040OG MXUV0
			24 × 48 × 72 pollici	18 × 48 × 72 pollici	20 × 40 × 60 pollici
UN	Maglia d'acciaio		5	5	4
B	palo verticale		8	8	8
C	Trave corta del ripiano superiore		10	10	8
D	Ripiano superiore trave lunga		10	10	8
E	Fissaggi		4	4	4
F	Tappo del palo		16	16	16
G	Rinforzante		5	5	4
H	Gancio		4	4	4
IO	Guanti		1 paio	1 paio	1 paio
J	Accessori antiribaltamento		2 set	2 set	2 set
E	Connettore		2	2	2
L	Martello		1	1	1
Altezza dei ripiani separati			36 pollici	36 pollici	30 pollici

Rivetti per travi di ripiano superiore ha s un design che consente alla rete d'acciaio di posizionarsi .

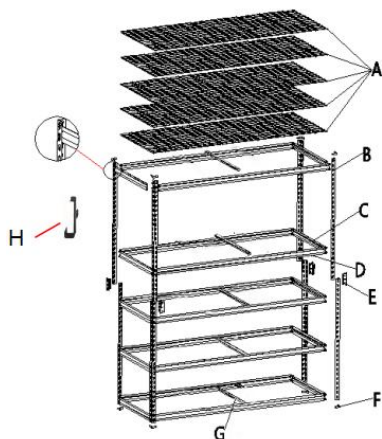

### Attenzione:

Per ulteriori informazioni sulle parti elencate di seguito, fare riferimento allo schema di montaggio in questo manuale. Disimballare e separare tutte le parti in un'area di lavoro libera.

## ASSEMBLY STEP

### Fase 1: assemblaggio del tappo del palo

1. Far scorrere ciascun palo (B) nel tappo del palo (F) come mostrato.
2. Ripetere la stessa operazione per tutti e 4 i pali verticali.

Attenzione: i copripalo sono adatti solo per i piedi in posizione verticale.

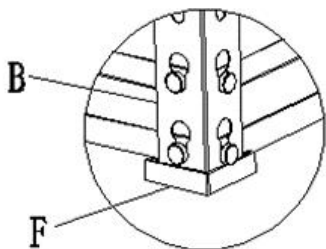

Top shelf beam rivets have a modified design, allowing Steel mesh to sit flush.

## Fase 2: Assemblaggio trave corta e lunga

1. Allineare le travi corte ( C ) e le travi lunghe del ripiano superiore ( D ) alle tacche allineate tra i quattro montanti verticali ( B ).
2. Una volta in posizione, picchiettare con decisione utilizzando un martello di gomma.
3. Ripetere il procedimento per il lato opposto, assicurandosi che entrambe le estremità sono impostati alla stessa altezza.

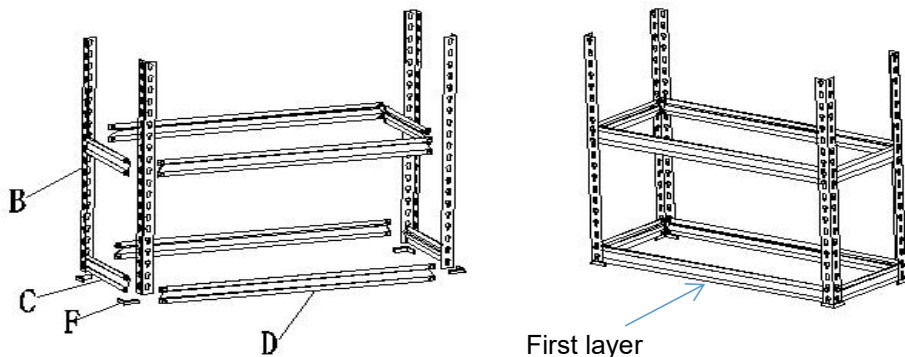

Nota:

- Mantenere il primo strato sollevato da terra entro 1-3 altezze dei fori per evitare che le colonne si deformino e crollino a causa dell'altezza eccessiva.
- Assicurarsi che l'altezza di ogni livello sia il più uniforme possibile.

## Fase 3: Assemblaggio dei fissaggi

1. Fissare i fissaggi (E) nella parte superiore del montante verticale (B) e picchiettare fino in fondo.



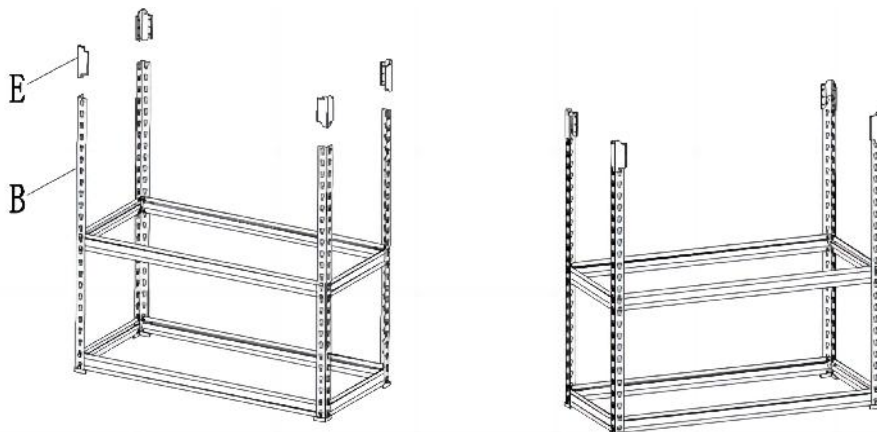

#### **Fase 4: installare il montante verticale**

1. La parte inferiore del montante verticale (B) viene fissata a ciascun elemento di fissaggio (E) e fissata fino in fondo.

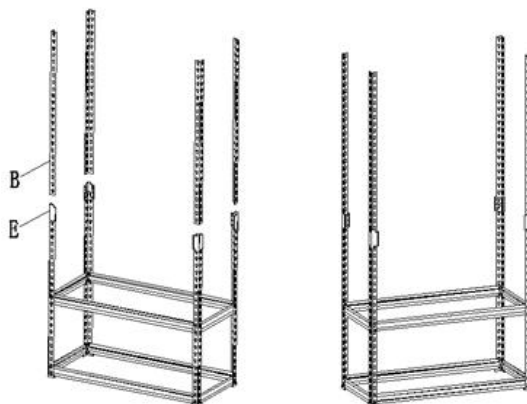

**Fase 5: installare la terza, quarta e quinta trave lunga del ripiano superiore (D) e la trave corta (C); il metodo di installazione è lo stesso della Fase 2.**



## Fase 6: installare il rinforzo.

1. installare la parte G su ciascuna parte D.

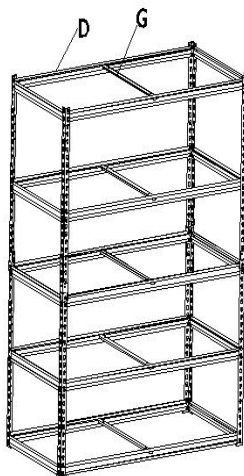

## Fase 7: Montaggio del ripiano superiore in rete d'acciaio

1. Inserire il ripiano superiore in rete d'acciaio (A) sui supporti del ripiano superiore.

2. Assicurarsi che sia a filo con la parte superiore del telaio dell'unità.

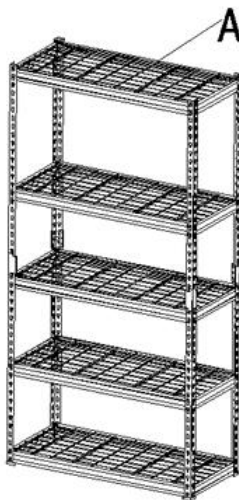

## Fase 8: Installare il piedino superiore per la colla

1. Far scorrere ciascun palo (B) nel tappo del palo (F) come mostrato.
2. Ripetere la stessa operazione per tutti e 4 i pali verticali.
3. Il montaggio è ora completato e l'unità è pronta per l'uso.
4. Gli accessori antiribaltamento (parte J) possono essere utilizzati per fissare il ripiano alla parete ed evitarne il ribaltamento.

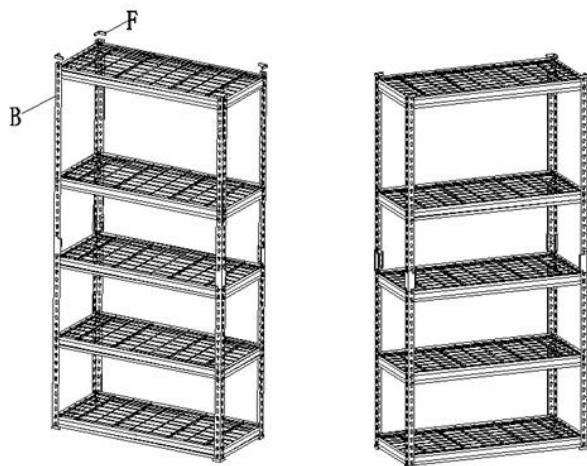

## Additional Functionality

7. Questo prodotto può essere separato in due ripiani . Puoi trovare l'altezza di ogni ripiano nella tabella degli elenchi dei pezzi .

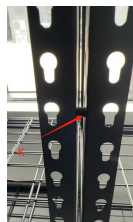
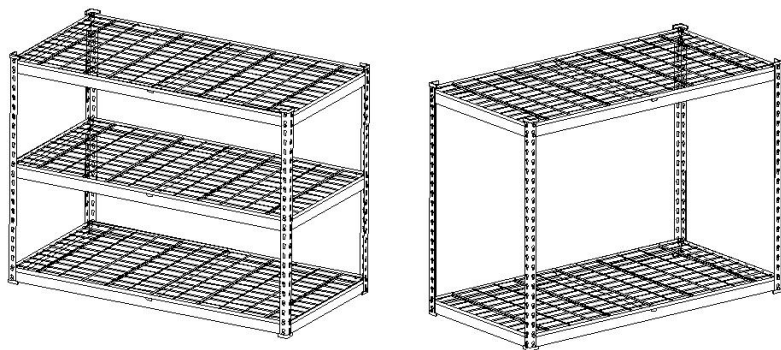

Nota: Una volta divisi per l'uso, i due ripiani possono essere collegati con la parte K come mostrato .

## **8. Conversione della rete metallica in pannelli laterali:**

Fissare il ripiano in rete d'acciaio al lato della scaffalatura utilizzando due (parte H).

### **2.1 Utilizzo appropriato:**

Questa configurazione è ideale per riporre utensili leggeri e di uso comune, come metri a nastro, pinze e martelli.

### **2.2 Precauzioni di sicurezza:**

Non utilizzare ganci eccessivamente lunghi per appendere oggetti grandi e pesanti, per evitare possibili lesioni causate dai ganci stessi o dalla caduta di oggetti.

Evitare di appendere oggetti pesanti che potrebbero causare il ribaltamento della scaffalatura.

### **2.3 Assegnazione del gancio:**

- Ogni pannello laterale deve essere sostenuto da due ganci. Sono forniti in totale quattro ganci, adatti per due pannelli laterali.
- A causa di problemi di allineamento con i fori, non utilizzare tutti e quattro i ganci per appendere un singolo pannello laterale, per garantire che il pannello possa essere installato correttamente.

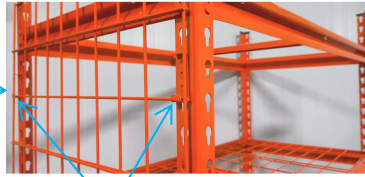

Hook

**Produttore:** Shanghaimuxinmuyeyouxiangongsi

**Indirizzo:** Shuangchenglu 803nong11hao1602A-1609shi, baoshanqu, shanghai 200000 CN.

**Importato in AUS:** SIHAO PTY LTD, 1 ROKEVA STREET EASTWOOD NSW 2122 Australia

**Importato negli USA:** Sanven Technology Ltd., Suite 250, 9166 Anaheim Place, Rancho Cucamonga, CA 91730

<b>EC</b>	<b>REP</b>
-----------	------------

E-CrossStu GmbH  
Mainzer Landstr.69, 60329 Frankfurt am Main.

<b>UK</b>	<b>REP</b>
-----------	------------

YH CONSULTING LIMITED.  
C/O YH Consulting Limited Office 147, Centurion House,  
London Road, Staines-upon-Thames, Surrey, TW18 4AX







**VEVOR**<sup>®</sup>

**TOUGH TOOLS, HALF PRICE**

**Tecnico Supporto e certificato di garanzia elettronica**

**[www.vevor.com/support](http://www.vevor.com/support)**

# **VEVOR<sup>®</sup>**

## **TOUGH TOOLS, HALF PRICE**

Soporte técnico y certificado de garantía electrónica

[www.vevor.com/support](http://www.vevor.com/support)

# **ESTANTE DE ALAMBRE DE ACERO**

## **MANUAL DEL USUARIO**

We continue to be committed to provide you tools with competitive price. "Save Half", "Half Price" or any other similar expressions used by us only represents an estimate of savings you might benefit from buying certain tools with us compared to the major top brands and does not necessarily mean to cover all categories of tools offered by us. You are kindly reminded to verify carefully when you are placing an order with us if you are actually saving half in comparison with the top major brands.

# VEVOR<sup>®</sup>

TOUGH TOOLS, HALF PRICE

## STEEL WIRE SHELF

**MODELO:** 6361QQUOV0 / 848E5KW7V0 / 040L9EDJV0 / 048EEK17V0  
448JA98TV0 / 8483M37BV0 / 040OGMXUV0

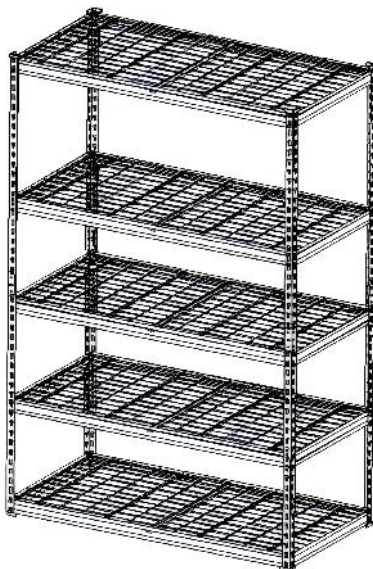



### NEED HELP? CONTACT US!

Have product questions? Need technical support? Please feel free to contact us:

**Technical Support and E-Warranty Certificate**  
**[www.vevor.com/support](http://www.vevor.com/support)**

This is the original instruction, please read all manual instructions carefully before operating. VEVOR reserves a clear interpretation of our user manual. The appearance of the product shall be subject to the product you received. Please forgive us that we won't inform you again if there are any technology or software updates on our product.

## IMPORTANT SAFETY INSTRUCTIONS

	Advertencia: Para reducir el riesgo de lesiones, el usuario debe leer atentamente el manual de instrucciones.
	Este símbolo, colocado antes de un comentario de seguridad, indica un tipo de precaución, advertencia o peligro. Ignorar esta advertencia puede provocar un accidente. Para reducir el riesgo de lesiones, incendios o electrocución, siga siempre las recomendaciones que se muestran a continuación.
	Advertencia: Asegúrese de usar guantes al utilizar este producto.

### **WARNING!**

- 33) Conserve este manual para conocer las advertencias y precauciones de seguridad. El manual ofrece información importante sobre cómo ensamblar, usar y mantener este producto.
- 34) Manipule los bordes metálicos con cuidado.
- 35) NO se suba a este producto ni lo utilice como escalera.
- 36) NO altere este producto de ninguna manera que no sea la prevista, ya que esto puede causar daños al producto o lesiones personales.
- 37) Monte siempre sobre una superficie nivelada.
- 38) El peso máximo cargado por cada estante no es más de 180 kg, distribuidos uniformemente.
- 39) Guarde los artículos más pesados en los estantes inferiores.
- 40) Fije la unidad a la pared si la va a llenar hasta su capacidad máxima (accesorios no incluidos).

## **PRECAUCIONES DE MONTAJE**

9. Por favor, ensamble el producto siguiendo estrictamente las instrucciones. Un montaje incorrecto podría resultar peligroso.
10. Utilice gafas de seguridad y guantes de trabajo adecuadamente durante el montaje.
3. No intente ensamblar el producto si se siente cansado o bajo la influencia de alcohol, drogas o medicamentos.
4. La capacidad de carga y otros parámetros del producto se aplican únicamente al producto ensamblado de forma correcta y completa.
5. Un martillo y un par de guantes. También se puede utilizar, siempre que se coloque un paño o un bloque de madera entre la cabeza del martillo y las piezas.

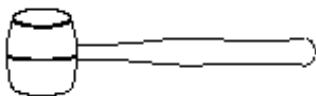

## **PRECAUCIONES DE USO**

1. Este producto no es un juguete. No permita que los niños jueguen con este artículo ni lo utilicen.
2. Verifique cuidadosamente antes de usar. No lo use si las piezas están sueltas o dañadas.
4. Úselo únicamente en superficies planas, niveladas y duras.
5. No exceda la capacidad de carga indicada . Apriete bien todas las perillas antes de colocar pesos sobre el producto . ¡Tenga en cuenta la capacidad de carga dinámica ! Los cambios repentinos de carga pueden provocar temporalmente una carga excesiva, lo que puede provocar una falla del producto.

## **GUARDE ESTAS INSTRUCCIONES**

## PRODUCT PARAMETERS

	1	2	3	4
Modelo	6361QQUOV0	848E5KW7V0	040L9EDJV0	048EEK17V0
Tamaño del producto / pulgada	16×36× 72	18 × 48 × 72	2 0 × 4 0 × 60	2 0 × 48 × 72
Dimensión: A × B / pulgada	33,5 × 13.5	15.5 × 45.5	17.5 × 37.5	17.5 × 45.5
Color	Negro	Negro	Negro	Negro
Capas	5	5	4	5
Límite de carga total	2000 libras	2 5 00 libras	2 4 00 libras	3000 libras
límite de carga para cada capa	400 libras	500 libras	600 libras	600 libras



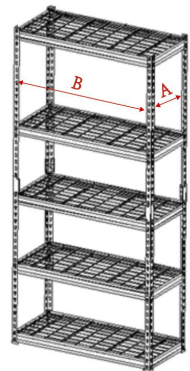





	5	6	7
Modelo	448JA98TV0	8483M37BV0	040OGMXUV0
Tamaño del producto / pulgada	24 × 48 × 72	18 × 48 × 72	2 0 × 4 0 × 60
Dimensión: A × B / pulgada	21,5 × 45.5	15.5 × 45.5	17.5 × 37.5
Color	Negro	Naranja	Naranja
Capas	5	5	4
Límite de carga total	3000 libras	2 5 00 libras	2 4 00 libras
límite de carga para cada capa	600 libras	500 libras	600 libras



capa			
------	--	--	--











**Nota:** Los objetos pesados deben distribuirse uniformemente en el estante para evitar deformaciones debido a la concentración de la carga. El peso máximo de un solo objeto pesado no debe superar los 30 kg.

## PART LIST

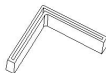
Parte	Descripción	Imagen	Cantidad de piezas			
			6361Q QUOV0	848E5 KW7V0	040L9 EDJV0	048EE K17V0
			16×36× 72 pulgadas	18 × 48 × 72 pulgadas	20 × 40 × 60 pulgadas	20 × 48 × 72 pulgadas
A	Malla de acero		5	5	4	5
B	Poste vertical		8	8	8	8
do	Estante superior de viga corta		10	10	8	10
D	Estante superior con viga larga		10	10	8	10
mi	Fijaciones		4	4	4	4
F	Tapa del poste		16	16	16	16
GR AM O	Reforzador		5	5	4	5
yo	Gancho		4	4	4	4

I	Guantes		1 par	1 par	1 par	1 par
Yo	Accesorios antivuelco		2 juegos	2 juegos	2 juegos	2 juegos
K	Conector		2	2	2	2
yo	Martillo		1	1	1	1
Altura de los estantes separados			36 pulgadas	36 pulgadas	30 pulgadas	36 pulgadas



Parte	Descripción	Imagen	Cantidad de piezas		
			448JA 98TV0	8483M 37BV0	040OG MXUV0
			24 × 48 × 72 pulgadas	18 × 48 × 72 pulgadas	20 × 40 × 60 pulgadas
A	Malla de acero		5	5	4
B	Poste vertical		8	8	8
do	Estante superior de viga corta		10	10	8
D	Estante superior con viga larga		10	10	8
mi	Fijaciones		4	4	4
F	Tapa del poste		16	16	16
GRAMO	Reforzador		5	5	4
yo	Gancho		4	4	4
I	Guantes		1 par	1 par	1 par
Yo	Accesorios antivuelco		2 juegos	2 juegos	2 juegos
K	Conector		2	2	2
yo	Martillo		1	1	1

Altura de los estantes separados		36 pulgadas	36 pulgadas	30 pulgadas
----------------------------------	--	----------------	----------------	----------------

Los remaches de la viga del estante superior tienen un diseño que permite que la malla de acero se asiente.

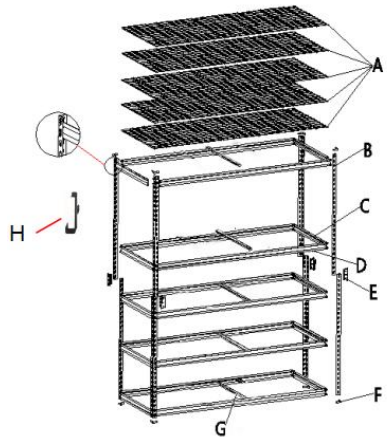

**Atención:**

Para obtener información adicional sobre las piezas que se enumeran a continuación, consulte el diagrama de ensamblaje de este manual. Desembale y separe todas las piezas en un área de trabajo despejada.

**ASSEMBLY STEP**

**Paso 1: Montaje de la tapa del poste**

1. Deslice cada poste (B) en la tapa del poste (F) como se muestra.
2. Repita el procedimiento para los 4 postes verticales.

Atención: Las tapas de los postes son solo para patas verticales.

Top shelf beam rivets have a modified design,

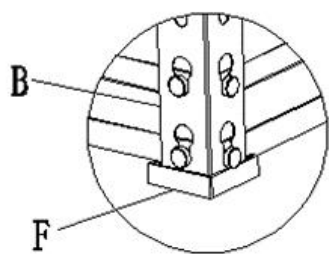

## Paso 2: Ensamblaje de vigas cortas y largas

1. Alinee las vigas cortas ( C ) y las vigas largas del estante superior ( D ) con las muescas alineadas entre los cuatro postes verticales ( B ).
2. Una vez en posición, golpéelo firmemente usando un mazo de goma.
3. Repita el proceso para el lado opuesto, asegurándose de que ambos extremos estén situados a la misma altura.

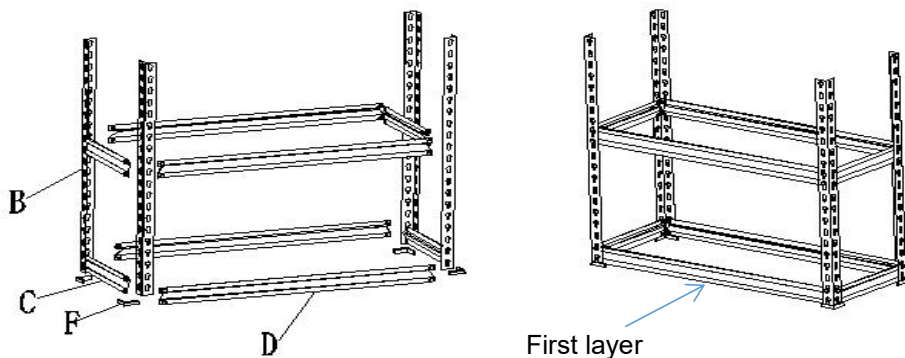

Nota:

- Mantenga la primera capa separada del suelo entre 1 y 3 alturas de agujeros para evitar que las columnas se deformen y colapsen debido a la altura excesiva.
- Asegúrese de que la altura de cada nivel sea lo más uniforme posible.

## Paso 3: Montaje de fijaciones

1. Fije las fijaciones (E) en la parte superior del poste vertical (B) y golpéelas hasta el final.

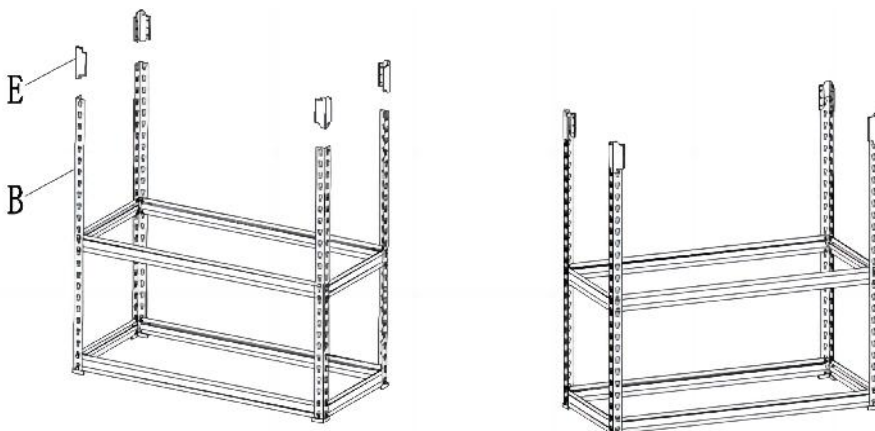

#### Paso 4: Instale el poste vertical

1. La parte inferior del poste vertical (B) se fija a cada fijación (E) y se golpea hasta el final.

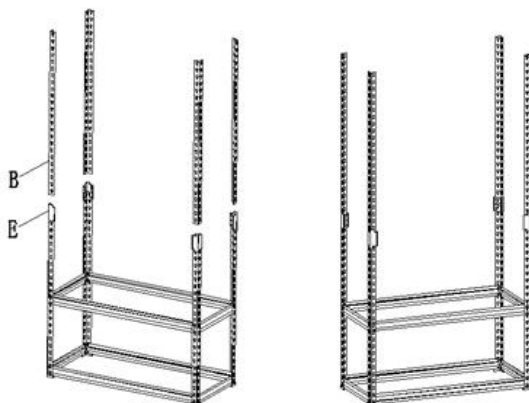

**Paso 5: Instale la tercera, cuarta y quinta viga larga (D) y la viga corta (C) del estante superior; el método de instalación es el mismo que el del paso 2.**



## Paso 6: Instale el reforzador.

1. Instale la parte G en cada parte D.

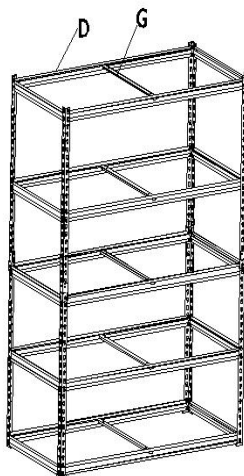

## Paso 7: Montaje del estante superior de malla de acero

1. Inserte el estante superior de malla de acero (A) sobre los soportes del estante superior.

2. Asegúrese de que quede al ras con la parte superior del marco de la unidad.

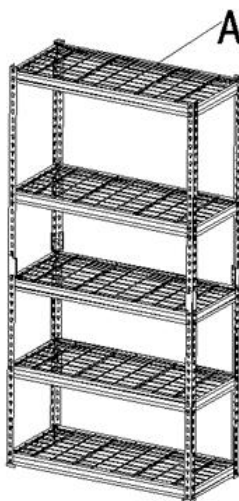

## Paso 8: Instale el pie adhesivo superior

1. Deslice cada poste (B) en la tapa del poste (F) como se muestra.
2. Repita el procedimiento para los 4 postes verticales.
3. El ensamblaje ahora está completo y su unidad está lista para usarse.
4. Se pueden utilizar accesorios antivuelco (Parte J) para asegurar el estante a la pared y evitar que se vuelque.

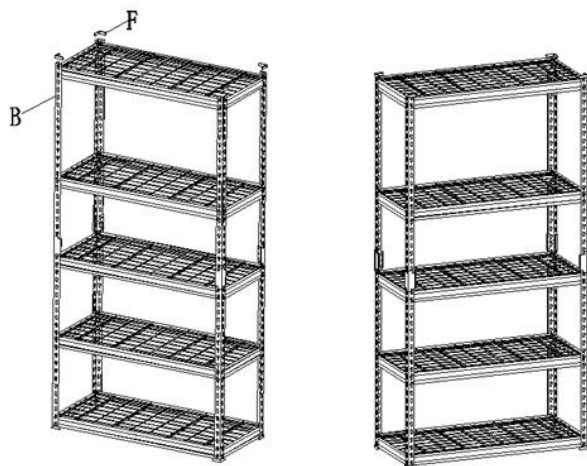

## Additional Functionality

9. Este producto se puede separar en dos estantes . Puede encontrar la altura de cada estante en la tabla de listas de piezas .

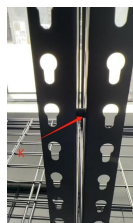
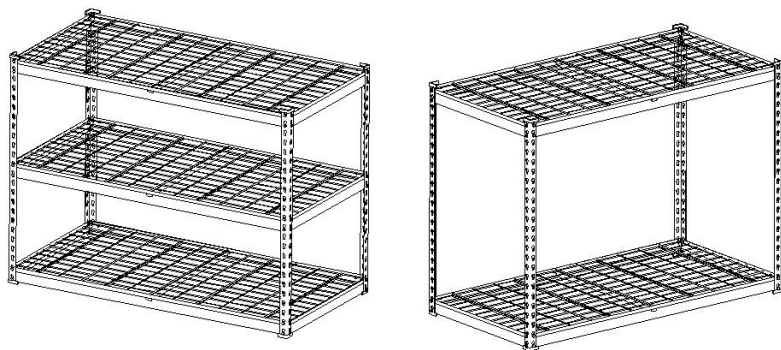

Nota: Cuando se dividen para su uso, los dos estantes se pueden conectar con la parte K como mostrado .

## **10. Conversión de malla de acero en paneles laterales:**

Fije el estante de malla de acero al costado de la estantería usando dos (Parte H).

### **2.1 Uso adecuado:**

Esta configuración es ideal para almacenar herramientas livianas de uso común, como cintas métricas, alicates y martillos.

### **2.2 Precauciones de seguridad:**

No utilice ganchos excesivamente largos para colgar objetos grandes y pesados para evitar posibles lesiones causadas por ganchos u objetos que caen.

Evite colgar objetos pesados que puedan provocar que las estanterías se vuelquen.

### **2.3 Asignación de ganchos:**

- Cada panel lateral debe estar sujeto por dos ganchos. Se proporcionan cuatro ganchos en total, adecuados para dos paneles laterales.
- Debido a problemas de alineación con los orificios, no utilice los cuatro ganchos para colgar un solo panel lateral para garantizar que el panel se pueda instalar correctamente.



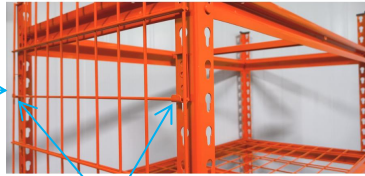

Hook

**Fabricante:** Shanghaimuxinmuyeyouxiangongsi

**Dirección:** Shuangchenglu 803nong11hao1602A-1609shi, baoshanqu, shanghai 200000 CN.

**Importado a AUS:** SIHAO PTY LTD, 1 ROKEVA STREETEASTWOOD NSW 2122 Australia

**Importado a EE. UU.:** Sanven Technology Ltd., Suite 250, 9166 Anaheim Place, Rancho Cucamonga, CA 91730

EC	REP
----	-----

E-CrossStu GmbH  
Mainzer Landstr.69, 60329 Frankfurt am Main.

UK	REP
----	-----

YH CONSULTING LIMITED.  
C/O YH Consulting Limited Office 147, Centurion House,  
London Road, Staines-upon-Thames, Surrey, TW18 4AX





**VEVOR<sup>®</sup>**

**TOUGH TOOLS, HALF PRICE**

**Técnico Certificado de soporte y garantía electrónica**

**[www.vevor.com/support](http://www.vevor.com/support)**

# **VEVOR<sup>®</sup>**

## **TOUGH TOOLS, HALF PRICE**

Wsparcie techniczne i certyfikat e-gwarancji

[www.vevor.com/support](http://www.vevor.com/support)

# **PÓŁKA Z DRUTU STALOWEGO**

## **INSTRUKCJA OBSŁUGI**

We continue to be committed to provide you tools with competitive price.

"Save Half", "Half Price" or any other similar expressions used by us only represents an estimate of savings you might benefit from buying certain tools with us compared to the major top brands and does not necessarily mean to cover all categories of tools offered by us. You are kindly reminded to verify carefully when you are placing an order with us if you are actually saving half in comparison with the top major brands.

# VEVOR®

TOUGH TOOLS, HALF PRICE

## STEEL WIRE SHELF

**MODELE:** 6361QQUOV0 / 848E5KW7V0 / 040L9EDJV0 / 048EEK17V0  
448JA98TV0 / 8483M37BV0 / 040OGMXUV0

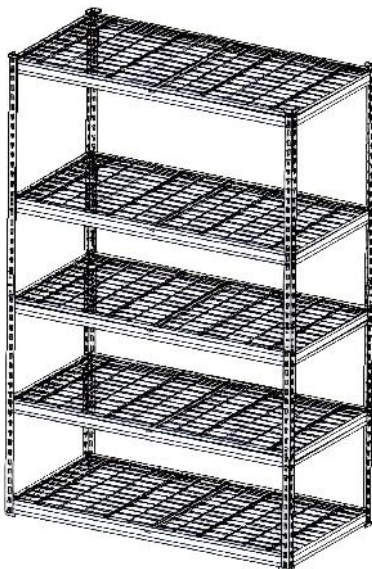



### NEED HELP? CONTACT US!

Have product questions? Need technical support? Please feel free to contact us:

**Technical Support and E-Warranty Certificate**  
**[www.vevor.com/support](http://www.vevor.com/support)**

This is the original instruction, please read all manual instructions carefully before operating. VEVOR reserves a clear interpretation of our user manual. The appearance of the product shall be subject to the product you received. Please forgive us that we won't inform you again if there are any technology or software updates on our product.

## IMPORTANT SAFETY INSTRUCTIONS

	Ostrzeżenie - Aby zminimalizować ryzyko obrażeń, użytkownik powinien uważnie przeczytać instrukcję obsługi.
	Ten symbol, umieszczony przed komentarzem dotyczącym bezpieczeństwa, wskazuje na rodzaj ostrożności, ostrzeżenia lub niebezpieczeństwa. Zignorowanie tego ostrzeżenia może doprowadzić do wypadku. Aby zmniejszyć ryzyko obrażeń, pożaru lub porażenia prądem, zawsze postępuj zgodnie z zaleceniami podanymi poniżej.
	Ostrzeżenie: Podczas stosowania tego produktu należy nosić rękawiczki.

### **WARNING!**

- 41) Zachowaj tę instrukcję ze względu na ostrzeżenia i środki ostrożności dotyczące bezpieczeństwa. Instrukcja zawiera ważne informacje na temat montażu, użytkowania i konserwacji tego produktu.
- 42) Prosimy o ostrożne obchodzenie się z krawędziami metalowymi.
- 43) NIE stawaj na tym produkcie i NIE używaj go jako drabiny.
- 44) NIE modyfikuj tego produktu w żaden sposób niezgodny z przeznaczeniem, gdyż może to spowodować uszkodzenie produktu lub obrażenia ciała.
- 45) Zawsze montuj na równej powierzchni.
- 46) Maksymalne obciążenie każdej półki nie przekracza 180 kg, przy równomiernym rozłożeniu ciężaru.
- 47) Przechowuj najcięższe przedmioty na dolnych półkach.
- 48) Jeśli zbiornik jest pełny, należy go przymocować do ściany (elementy mocujące nie są dołączone).

## **ŚRODKI OSTROŻNOŚCI PODCZAS MONTAŻU**

11. Proszę złożyć produkt ściśle według instrukcji. Nieprawidłowy montaż może być niebezpieczny.
12. Podczas montażu należy prawidłowo założyć okulary ochronne i rękawice robocze.
3. Nie należy podejmować prób montażu produktu, jeśli jest się zmęczonym lub pod wpływem alkoholu, narkotyków lub leków.
4. Nośność i inne parametry produktu odnoszą się wyłącznie do produktu prawidłowo i kompletnie zmontowanego.
5. Młotek i para rękawiczek Można również stosować tę metodę, pod warunkiem umieszczenia szmatki lub klocka drewnianego między głowicą młotka a częściami.

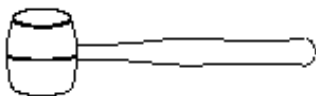

## **ŚRODKI OSTROŻNOŚCI**

1. Ten produkt nie jest zabawką. Nie pozwalaj dzieciom bawić się tym przedmiotem ani mieć do niego dostępu.
2. Przed użyciem sprawdź dokładnie. Nie używaj, jeśli części się poluzują lub ulegną uszkodzeniu.
4. Stosować wyłącznie na płaskich, równych i twardych powierzchniach.
5. Nie przekraczaj podanej nośności . Mocno dokręć wszystkie pokrętła przed umieszczeniem na nim ciężarków . Zwróć uwagę na dynamiczną nośność ! Nagłe zmiany obciążenia mogą tymczasowo spowodować nadmierne obciążenie, co może doprowadzić do uszkodzenia produktu.

## **ZAPISZ TE INSTRUKCJE**



## PRODUCT PARAMETERS

	1	2	3	4
Model	6361QQUOV0	848E5KW7V0	040L9EDJV0	048EEK17V0
Rozmiar produktu / cal	16×36× 72	18 ×48× 72	2 0 × 4 0 × 60	2 0 × 48 × 72
Wymiar : A × B / cal	33,5 × 13.5	15,5 × 45.5	17,5 × 37.5	17,5 × 45.5
Kolor	Czarny	Czarny	Czarny	Czarny
Warstwy	5	5	4	5
Całkowity limit obciążenia	2000 funtów	2 5 00 funtów	2 4 00 funtów	3000 funtów
limit obciążenia dla każdej warstwy	400 funtów	5 00 funtów	6 00 funtów	6 00 funtów



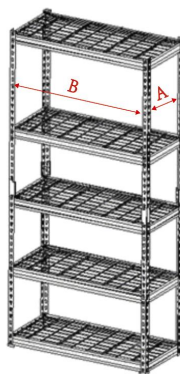





	5	6	7
Model	448JA98TV0	8483M37BV0	040OGMXUV0
Rozmiar produktu / cal	24 × 48 × 72	18 × 48 × 72	2 0 × 4 0 × 60
Wymiar: A × B / cal	21,5 × 45.5	15,5 × 45.5	17,5 × 37.5
Kolor	Czarny	Pomarań czowy	Pomarańczowy
Warstwy	5	5	4
Całkowity limit obciążenia	3 000 funtów	2 5 00 funtów	2 4 00 funtów
limit	6 00 funtów	5 00 funtów	6 00 funtów













obciążenia dla każdej warstwy			
-------------------------------------	--	--	--

**Uwaga:** Ciężkie przedmioty powinny być równomiernie rozłożone na półce, aby uniknąć deformacji spowodowanej skoncentrowanym obciążeniem. Maksymalna waga pojedynczego ciężkiego przedmiotu nie powinna przekraczać 30 kg.

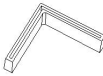
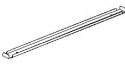
## PART LIST

Część	Opis	Zdjęcie	Ilość części			
			6361P KOLORO WO	848E5 KW7V0	040L9 EDJV0	048EE K17V0
			16×36× 72 cale	18 ×48× 72 cale	2 0 × 4 0 × 60 cali	2 0 × 48 × 72 cale
A	Siatka stalowa		5	5	4	5
B	Słupek pionowy		8	8	8	8
C	Górna półka krótka belka		10	10	8	10
D	Długa belka górnej półki		10	10	8	10
mi	Mocowania		4	4	4	4
F	Czapka słupka		16	16	16	16
G	Wzmacniacz		5	5	4	5
H	Hak		4	4	4	4

I	Rękawice		1 para	1 para	1 para	1 para
J	Akcesoria zabezpieczające przed wywróceniem		2 zestawy	2 zestawy	2 zestawy	2 zestawy
K	Złącze		2	2	2	2
L	Młotek		1	1	1	1
Wysokość oddzielnych pótek			36 cali	36 cali	30 cali	36 cali

Część	Opis	Zdjęcie	Ilość części		
			448JA 98TV0	8483 mln 37BV0	040OG MXUV0
			24 × 48 × 72 cale	18 × 48 × 72 cale	20 × 40 × 60 cali
A	Siatka stalowa		5	5	4
B	Słupek pionowy		8	8	8
C	Górna półka krótka belka		10	10	8
D	Długa belka górnej półki		10	10	8
mi	Mocowania		4	4	4
F	Czapka słupka		16	16	16
G	Wzmacniacz		5	5	4
H	Hak		4	4	4
I	Rękawice		1 para	1 para	1 para
J	Akcesoria zabezpieczające przed wywróceniem		2 zestawy	2 zestawy	2 zestawy
K	Złącze		2	2	2
L	Młotek		1	1	1

Wysokość oddzielnych półek		36 cali	36 cali	30 cali
----------------------------	--	---------	---------	---------

Nity belki górnej półki mają konstrukcja umożliwiającą osadzenie siatki stalowej .

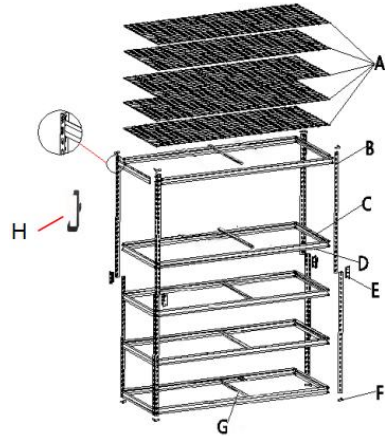

### Uwaga:

Aby uzyskać dodatkowe informacje dotyczące części wymienionych poniżej, zapoznaj się ze schematem montażu w tym podręczniku. Rozpakuj i oddziel wszystkie części w czystym miejscu roboczym.

## ASSEMBLY STEP

### Krok 1: Montaż nasadki słupka

1. Wsuń każdy słupek (B) do nasadki słupka (F), jak pokazano.
2. Powtórz tę czynność dla wszystkich 4 słupków pionowych.

Uwaga: Nakładki na słupki przeznaczone są wyłącznie do nóg w pozycji pionowej.

Top shelf beam rivets have  
a modified design,

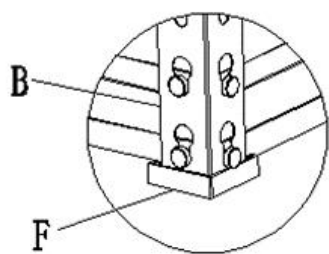

## Krok 2: Montaż belki krótkiej i długiej

1. Wyrównaj krótkie belki ( C ) i długie belki górnej półki ( D ) z wyrównanymi wycięciami pomiędzy czterema pionowymi słupkami ( B ).
2. Po umieszczeniu na miejscu należy mocno uderzyć gumowym młotkiem.
3. Powtórz proces po przeciwnej stronie, upewniając się, że oba końce są dobrze połączone.  
są ustawione na tej samej wysokości.

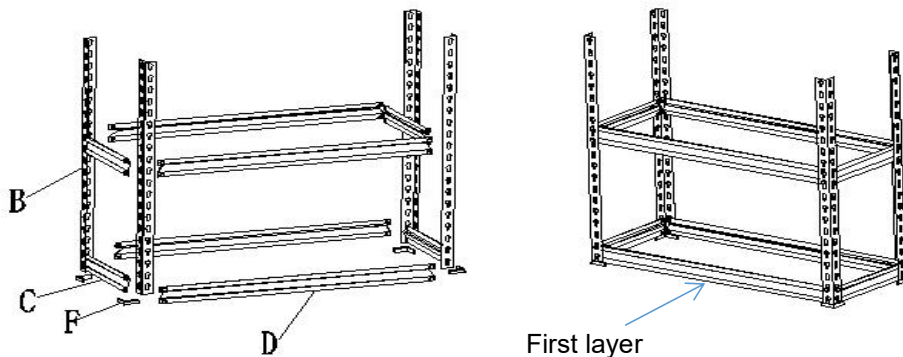

Notatka:

- Utrzymuj pierwszą warstwę nad ziemią na wysokości od 1 do 3 otworów, aby zapobiec odkształceniu i zawaleniu się kolumn z powodu zbyt dużej wysokości.
- Upewnij się, że wysokość każdego poziomu jest możliwie najbardziej jednolita.

## Krok 3: Montaż elementów mocujących

1. Zamontuj elementy mocujące ( E ) na górze słupka pionowego ( B ) i dobij je do końca.

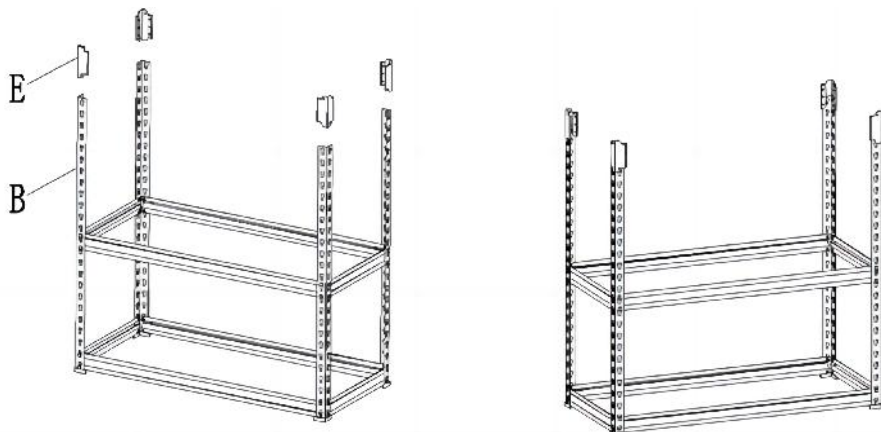

#### **Krok 4: Zainstaluj słupek pionowy**

1. Dolną część słupka pionowego (B) należy przymocować do każdego mocowania (E), a następnie dobić do końca.

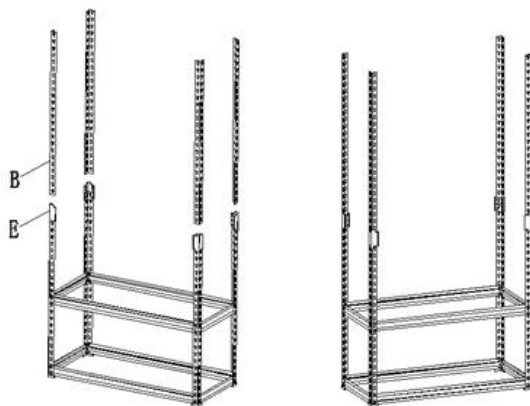

**Krok 5: Zamontuj trzecią, czwartą i piątą górną półkę – długą belkę (D) i krótką belkę (C); metoda montażu jest taka sama, jak w kroku 2.**





## Krok 6: Zainstaluj wzmocniacz.

1. Zamontuj część G na każdej części D.

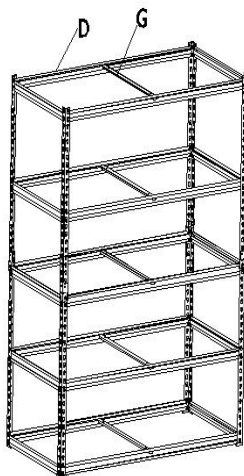

## Krok 7: Montaż górnej półki z siatki stalowej

1. Włóż górną półkę z siatki stalowej (A) na wsporniki górnej półki.
2. Upewnij się, że przylega równo do górnej krawędzi ramy urządzenia.

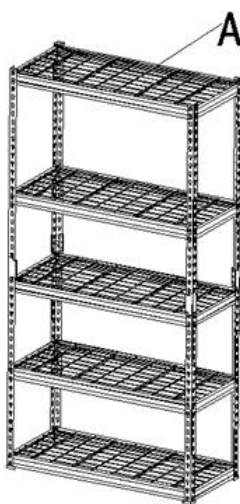

## Krok 8: Zamontuj górną stopkę klejącą

1. Wsuń każdy słupek (B) do nasadki słupka (F), jak pokazano.
2. Powtórz tę czynność dla wszystkich 4 słupków pionowych.
3. Montaż jest teraz ukończony i urządzenie jest gotowe do użycia.
4. Akcesoria zabezpieczające (część J) można wykorzystać do zabezpieczenia półki przed przewróceniem się, aby przymocować ją do ściany.

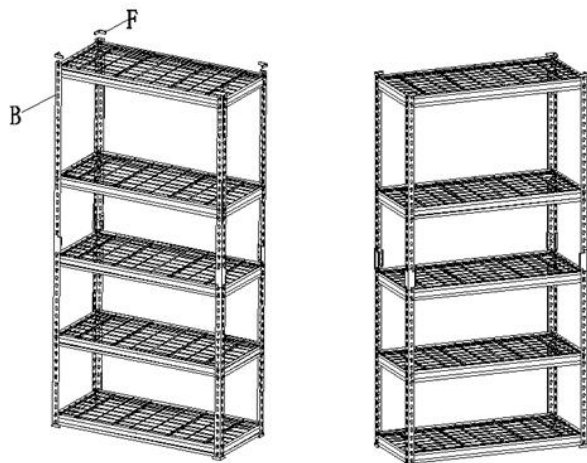

## Additional Functionality

11. Ten produkt można rozdzielić na dwie półki . Wysokość każdej półki można znaleźć w tabeli list części .

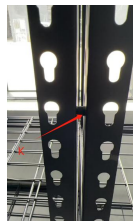
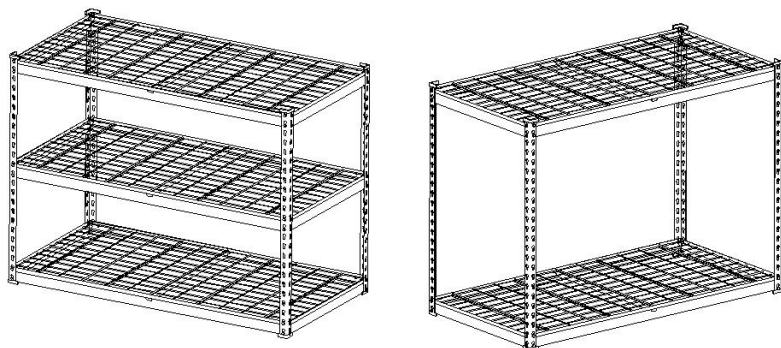

Notatka: Po rozdzieleniu w celu użycia, dwie półki można połączyć za

pomocą części K jako pokazano .

## **12. Konwersja siatki stalowej na panele boczne:**

Przymocuj półkę z siatki stalowej do boku regału za pomocą dwóch (część H).

### **2.1 Właściwe zastosowanie:**

Tego typu rozwiązanie jest idealne do przechowywania powszechnie używanych, lekkich narzędzi, takich jak miary krawieckie, szcypce i młotki.

### **2.2 Środki ostrożności:**

Nie używaj zbyt długich haków do wieszania dużych, ciężkich przedmiotów, aby uniknąć potencjalnych obrażeń spowodowanych hakami lub spadającymi przedmiotami.

Unikaj wieszania ciężkich przedmiotów, które mogą spowodować przewrócenie się regału.

### **2.3 Przydział haka:**

- Każdy panel boczny powinien być podparty dwoma haczykami. Łącznie przewidziano cztery haki, odpowiednie dla dwóch paneli bocznych.
- Ze względu na problemy z wyrównaniem otworów, nie używaj wszystkich czterech haczyków do zawieszania pojedynczego panelu bocznego, aby mieć pewność, że panel zostanie zainstalowany prawidłowo.

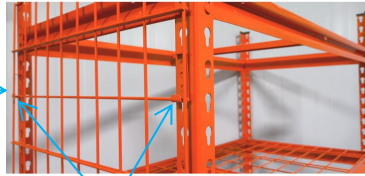

Hook

**Producent:** Shanghaimuxinmuyeyouxiangongsi

**Adres:** Shuangchenglu 803nong11hao1602A-1609shi, baoshanqu, szanghaj 200000 CN.

**Importowane do AUS:** SIHAO PTY LTD, 1 ROKEVA STREETEASTWOOD NSW 2122 Australia

**Importowane do USA:** Sanven Technology Ltd., Suite 250, 9166 Anaheim Place, Rancho Cucamonga, CA 91730

EC	REP
----	-----

E-CrossStu GmbH  
Mainzer Landstr.69, 60329 Frankfurt am Main.

UK	REP
----	-----

YH CONSULTING LIMITED.  
C/O YH Consulting Limited Office 147, Centurion House,  
London Road, Staines-upon-Thames, Surrey, TW18 4AX





**VEVOR<sup>®</sup>**

**TOUGH TOOLS, HALF PRICE**

**Techniczny Wsparcie i certyfikat e-gwarancji**

**[www.vevor.com/support](http://www.vevor.com/support)**



# **VEVOR<sup>®</sup>**

## **TOUGH TOOLS, HALF PRICE**

Technische ondersteuning en e-garantiecertificaat

[www.vevor.com/support](http://www.vevor.com/support)

# **STALEN DRAADPLANK GEBRUIKSAANWIJZING**

We continue to be committed to provide you tools with competitive price.

"Save Half", "Half Price" or any other similar expressions used by us only represents an estimate of savings you might benefit from buying certain tools with us compared to the major top brands and does not necessarily mean to cover all categories of tools offered by us. You are kindly reminded to verify carefully when you are placing an order with us if you are actually saving half in comparison with the top major brands.

# VEVOR®

TOUGH TOOLS, HALF PRICE

## STEEL WIRE SHELF

**MODEL:** 6361QQUOV0 / 848E5KW7V0 / 040L9EDJV0 / 048EEK17V0  
448JA98TV0 / 8483M37BV0 / 040OGMXUV0

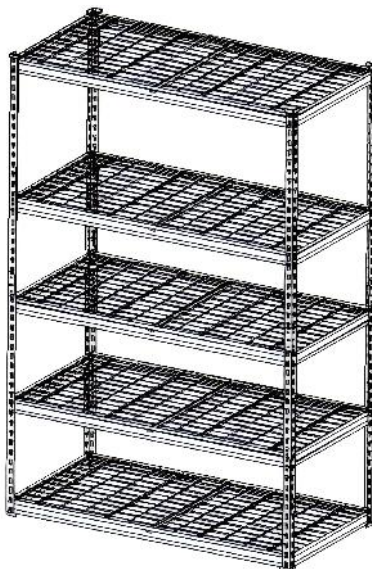



### NEED HELP? CONTACT US!

Have product questions? Need technical support? Please feel free to contact us:

**Technical Support and E-Warranty Certificate**  
**[www.vevor.com/support](http://www.vevor.com/support)**

This is the original instruction, please read all manual instructions carefully before operating. VEVOR reserves a clear interpretation of our user manual. The appearance of the product shall be subject to the product you received. Please forgive us that we won't inform you again if there are any technology or software updates on our product.

## IMPORTANT SAFETY INSTRUCTIONS

	Waarschuwing - Om het risico op letsel te verkleinen, dient de gebruiker de gebruiksaanwijzing zorgvuldig te lezen.
	Dit symbool, geplaatst voor een veiligheidsopmerking, geeft een soort voorzorgsmaatregel, waarschuwing of gevaar aan. Het negeren van deze waarschuwing kan leiden tot een ongeluk. Om het risico op letsel, brand of elektrocutie te verminderen, dient u altijd de onderstaande aanbevelingen op te volgen.
	Waarschuwing: draag handschoenen wanneer u dit product gebruikt.

### **WARNING!**

- 49) Bewaar deze handleiding voor de veiligheidswaarschuwingen en voorzorgsmaatregelen. De handleiding biedt belangrijke informatie over hoe u dit product kunt monteren, gebruiken en onderhouden.
- 50) Ga voorzichtig om met metalen randen.
- 51) Ga NIET op dit product staan en gebruik het niet als ladder.
- 52) Wijzig dit product NIET op een manier die niet de bedoeling is, omdat dit schade aan het product of persoonlijk letsel kan veroorzaken.
- 53) Monteer het geheel altijd op een vlakke ondergrond.
- 54) Het maximale belastbare gewicht per plank bedraagt maximaal 180 kg, gelijkmatig verdeeld.
- 55) Bewaar de zwaarste spullen op de onderste planken.
- 56) Bevestig het apparaat aan de muur als u het tot de maximale capaciteit wilt vullen (bevestigingsstukken niet inbegrepen).

## **MONTAGEVOORZORGSMAATREGELEN**

13. Monteer het product strikt volgens de instructies. Onjuiste montage kan gevaarlijk zijn.
14. Draag tijdens de montage een veiligheidsbril en werkhandschoenen.
3. Probeer het product niet in elkaar te zetten als u zich moe voelt of onder invloed bent van alcohol, drugs of medicijnen.
4. Het draagvermogen en andere productparameters worden uitsluitend toegepast op een correct en volledig gemonteerd product.
5. Een hamer en een paar handschoenen kan ook worden gebruikt, mits er een doek of blok hout tussen de hamerkop en de onderdelen wordt geplaatst.

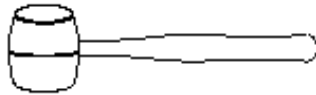

## **GEBRUIK VOORZORGSMAATREGELEN**

1. Dit product is geen speelgoed. Laat kinderen niet met dit item spelen of toegang ertoe krijgen.
2. Controleer zorgvuldig voor gebruik. Gebruik het niet als onderdelen losraken of beschadigd raken.
4. Alleen gebruiken op vlakke, vlakke en harde oppervlakken.
5. Overschrijd de vermelde draagkracht niet . Draai alle knoppen stevig vast voordat u er gewichten op plaatst . Wees u bewust van de dynamische draagkracht ! Plotselinge veranderingen in de belasting kunnen tijdelijk een te hoge belasting veroorzaken, wat kan leiden tot productfalen.

## **BEWAAR DEZE INSTRUCTIES**

## PRODUCT PARAMETERS

	1	2	3	4
Model	6361QQUOV0	848E5KW7V0	040L9EDJV0	048EEK17V0
Productgrootte / duim	16×36× 72	18 × 48 × 72	2 0 × 4 0 × 60	2 0 × 48 × 72
Afmeting: Een × B / duim	33,5 × 13.5	15.5 × 45.5	17.5 × 37.5	17.5 × 45.5
Kleur	Zwart	Zwart	Zwart	Zwart
Lagen	5	5	4	5
Totale belastinglimiet	2000 pond	2 500 pond	2 400 pond	3000 pond
belastinglimiet voor elke laag	400 pond	500 pond	600 pond	600 pond



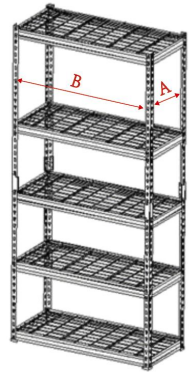







	5	6	7
Model	448JA98TV0	8483M37BV0	040OGMXUV0
Productgrootte	24 × 48 × 72 inch	18 × 48 × 72 inch	2 0 × 4 0 × 60 inch
Dimensie: Een × B / duim	21.5 × 45.5	15.5 × 45.5	17.5 × 37.5
Kleur	Zwart	Oranje	Oranje
Lagen	5	5	4
Totale belastinglimiet	3000 pond	2 500 pond	2 400 pond
belastinglimiet voor elke laag	600 pond	500 pond	600 pond













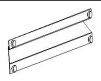

**Let op:** Zware objecten moeten gelijkmatig over de plank worden verdeeld om vervorming door geconcentreerde belasting te voorkomen. Het maximale gewicht van een enkel zwaar object mag niet meer dan 30

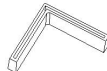
kg bedragen.

## PART LIST

Deel	Beschrijving	Afbeelding	Onderdeel Hoeveelheid			
			6361Q QUOV0	848E5 KW7V0	040L9 EDJV0	048EE K17V0
			16×36× 72 inch	18 ×48× 72 inch	20 × 40 × 60 inch	20 × 48 × 72 inch
A	Stalen gaas		5	5	4	5
B	Rechtopstaande paal		8	8	8	8
C	Bovenste plank korte balk		10	10	8	10
D	Bovenste plank lange balk		10	10	8	10
Ik	Bevestigingen		4	4	4	4
F	Postdop		16	16	16	16
G	Versterker		5	5	4	5
H	Haak		4	4	4	4
I	Handschoenen		1 paar	1 paar	1 paar	1 paar
J	Anti-kantel accessoires		2 sets	2 sets	2 sets	2 sets
Ik	Verbindingsstuk		2	2	2	2

Ik	Hamer		1	1	1	1
Hoogte van de gescheiden planken			36 inch	36 inch	30 inch	36 inch

Deel	Beschrijving	Afbeelding	Onderdeel Hoeveelheid		
			448JA 98TV0	8483M 37BV0	040OG MXUV0
			24 × 48 × 72 inch	18 × 48 × 72 inch	20 × 40 × 60 inch
A	Stalen gaas		5	5	4
B	Rechtopstaande paal		8	8	8
C	Bovenste plank korte balk		10	10	8
D	Bovenste plank lange balk		10	10	8
Ik	Bevestigingen		4	4	4
F	Postdop		16	16	16
G	Versterker		5	5	4
H	Haak		4	4	4
I	Handschoenen		1 paar	1 paar	1 paar
J	Anti-kantel accessoires		2 sets	2 sets	2 sets
Ik	Verbindingsstuk		2	2	2
Ik	Hamer		1	1	1
Hoogte van de gescheiden planken			36 inch	36 inch	30 inch



Bovenste plankbalk klinknagels hebben s een ontwerp waarbij het stalen gaas kan blijven zitten .

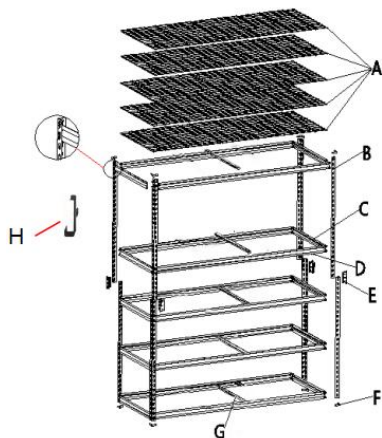

### Aandacht:

Voor aanvullende informatie over de hieronder vermelde onderdelen, raadpleegt u het montageschema in deze handleiding. Pak alle onderdelen uit en scheid ze in een open werkgebied.

## ASSEMBLY STEP

### Stap 1: Montage van de paalkap

1. Schuif elke paal (B) in de paalkap (F) zoals afgebeeld.
2. Herhaal dit voor alle 4 de staande palen.

Let op: Paaldoppen zijn alleen geschikt voor staande voeten.

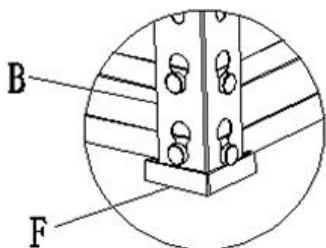

## Stap 2: Montage van korte en lange balken

1. Lijn de korte balken ( C ) en de lange balken van de bovenste plank ( D ) uit met de uitgelijnde inkepingen tussen de vier rechtopstaande palen ( B ).
2. Zodra de onderdelen op hun plaats zitten, tikt u ze stevig aan met een rubberen hamer.
3. Herhaal het proces aan de andere kant en zorg ervoor dat beide uiteinden op dezelfde hoogte zijn ingesteld.

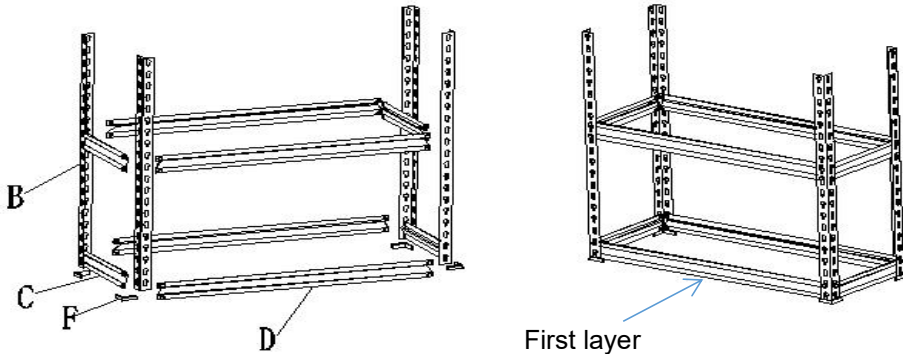

Opmerking:

- Zorg ervoor dat de eerste laag 1 tot 3 gaten hoger is dan de grond, om te voorkomen dat de kolommen vervormen en instorten vanwege de te hoge hoogte.
- Zorg ervoor dat de hoogte van elk niveau zo gelijk mogelijk is.

## Stap 3: Montage van de bevestigingen

1. Bevestig de bevestigingen ( E ) bovenaan de staander ( B ) en tik ze tot het einde vast.

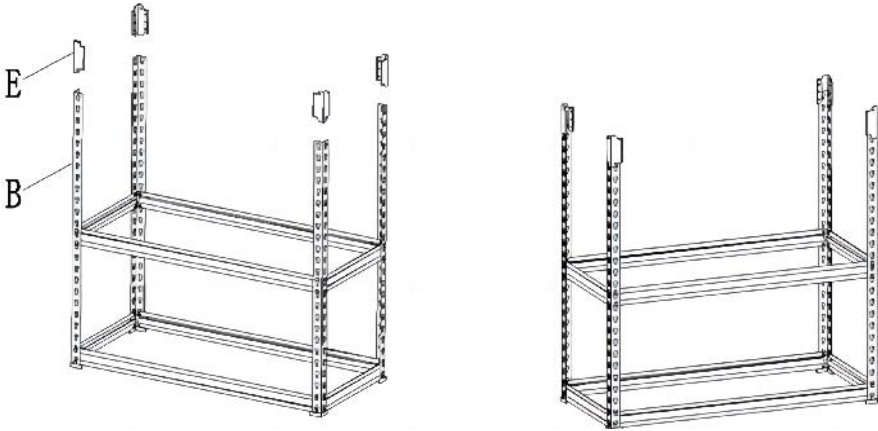

#### Stap 4: De staande paal installeren

1. De onderkant van de staander (B) wordt aan elke bevestiging (E) vastgemaakt en tot het einde vastgeschroefd.

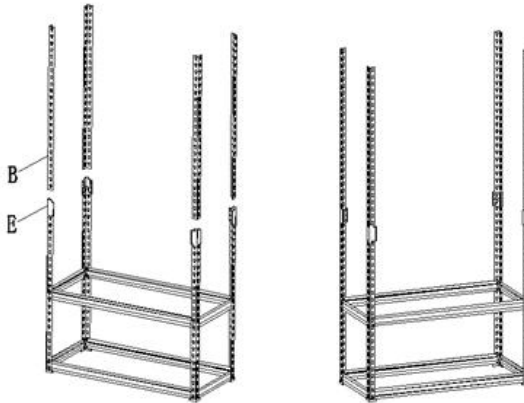

**Stap 5: Installeer de derde, vierde en vijfde bovenste plank, de lange balk (D) en de korte balk (C). De installatiemethode is hetzelfde als in stap 2.**



## Stap 6: Installeer de versteviger.

1. Installeer onderdeel G op elk onderdeel D.

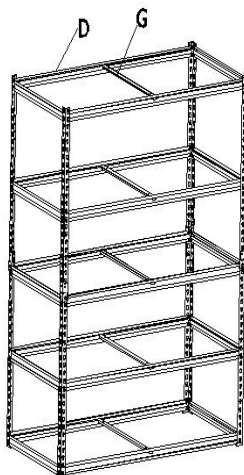

## Stap 7: Montage van de stalen gaasbovenplank

1. Plaats de bovenste plank van staalgaas (A) op de steunen van de bovenste plank.
2. Zorg ervoor dat het gelijk ligt met de bovenkant van het frame van de unit.

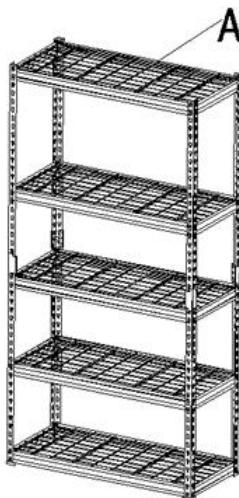

## Stap 8: Installeer de bovenste lijmvoot

1. Schuif elke paal (B) in de paalkap (F) zoals afgebeeld.
2. Herhaal dit voor alle 4 de staande palen.
3. De montage is nu voltooid en uw apparaat is klaar voor gebruik.
4. Met behulp van anti-kantelaccessoires (onderdeel J) kunt u de plank aan de muur bevestigen om kantelen te voorkomen.

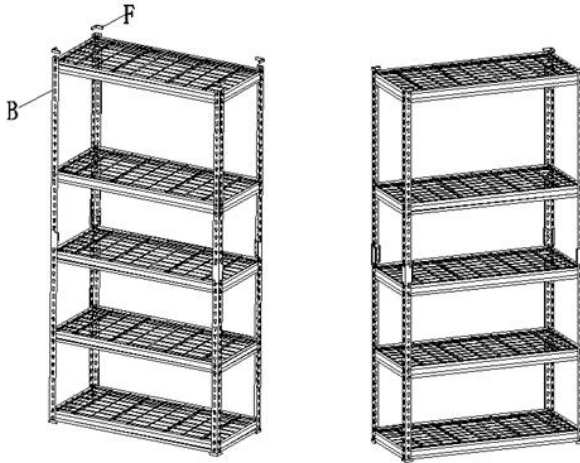

## Additional Functionality

13. Dit product kan worden verdeeld in twee planken . U kunt de hoogte van elke plank vinden in de tabel met stuklijsten .

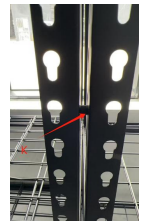
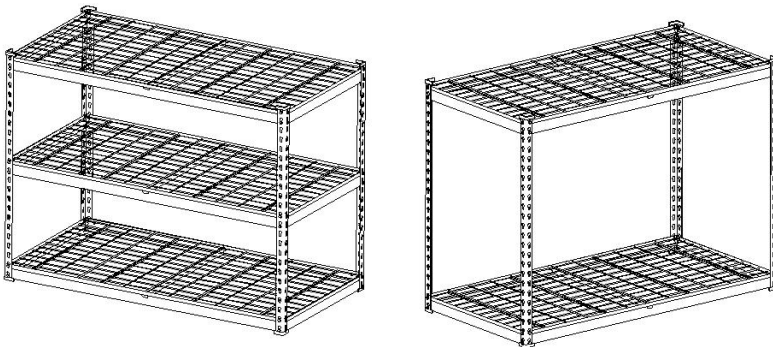

Opmerking: Bij gebruik kunnen de twee planken met deel K worden verbonden. getoond .

## 14. Conversie van stalen gaas naar zijpanelen:

Bevestig het stalen gaasschap met twee schroeven aan de zijkant van de stellingkast (onderdeel H).

### 2.1 Geschikt gebruik:

Deze opstelling is ideaal voor het opbergen van veelgebruikte, lichte gereedschappen zoals rolmaten, tangen en hamers.

### 2.2 Veiligheidsmaatregelen:

Gebruik geen te lange haken om grote, zware voorwerpen op te hangen.

Zo voorkomt u verwondingen door haken of vallende voorwerpen.

Hang geen zware voorwerpen op, want daardoor kunnen de planken omvallen.

### 2.3 Hook-toewijzing:

- Elk zijpaneel moet worden ondersteund door twee haken. Er worden in totaal vier haken meegeleverd, geschikt voor twee zijpanelen.
- Vanwege uitlijningsproblemen met de gaten mag u niet alle vier de haken gebruiken om één zijpaneel op te hangen. Zo weet u zeker dat het paneel correct kan worden geïnstalleerd.



Hook

**Fabrikant:** Shanghaimuxinmuyeyouxiangongsi

**Adres:** Shuangchenglu 803nong11hao1602A-1609shi, baoshanqu, shanghai 200000 CN.

**Geïmporteerd naar AUS:** SIHAO PTY LTD, 1 ROKEVA STREETEASTWOOD NSW 2122 Australië

**Geïmporteerd naar de VS:** Sanven Technology Ltd., Suite 250, 9166 Anaheim Place, Rancho Cucamonga, CA 91730

<b>EC</b>	<b>REP</b>
-----------	------------

E-CrossStu GmbH  
Mainzer Landstr.69, 60329 Frankfurt am Main.

<b>UK</b>	<b>REP</b>
-----------	------------

YH CONSULTING LIMITED.  
C/O YH Consulting Limited Office 147, Centurion House,  
London Road. Staines-upon-Thames. Surrey. TW18 4AX





**VEVOR**<sup>®</sup>

**TOUGH TOOLS, HALF PRICE**

**Technisch Ondersteuning en E-garantiecertificaat**

**[www.vevor.com/support](http://www.vevor.com/support)**

# **VEVOR®**

## **TOUGH TOOLS, HALF PRICE**

Teknisk support och e-garanticertifikat

[www.vevor.com/support](http://www.vevor.com/support)

# **STÅLTRÅDSHYLLA**

## **ANVÄNDARMANUAL**

We continue to be committed to provide you tools with competitive price.

"Save Half", "Half Price" or any other similar expressions used by us only represents an estimate of savings you might benefit from buying certain tools with us compared to the major top brands and does not necessarily mean to cover all categories of tools offered by us. You are kindly reminded to verify carefully when you are placing an order with us if you are actually saving half in comparison with the top major brands.

# VEVOR®

TOUGH TOOLS, HALF PRICE

## STEEL WIRE SHELF

**MODELL:** 6361QQUOV0 / 848E5KW7V0 / 040L9EDJV0 / 048EEK17V0  
448JA98TV0 / 8483M37BV0 / 040OGMXUV0

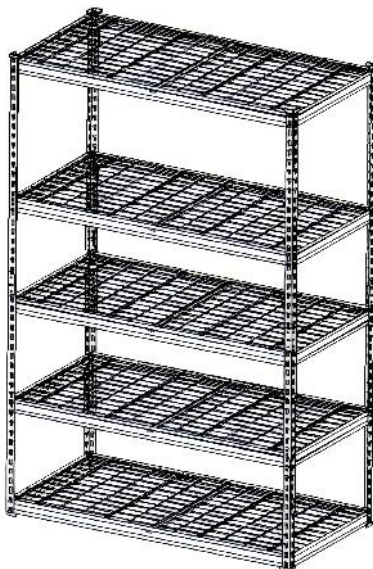



### NEED HELP? CONTACT US!

Have product questions? Need technical support? Please feel free to contact us:

**Technical Support and E-Warranty Certificate**  
**[www.vevor.com/support](http://www.vevor.com/support)**

This is the original instruction, please read all manual instructions carefully before operating. VEVOR reserves a clear interpretation of our user manual. The appearance of the product shall be subject to the product you received. Please forgive us that we won't inform you again if there are any technology or software updates on our product.

## IMPORTANT SAFETY INSTRUCTIONS

	Varning - För att minska risken för skada måste användaren läsa bruksanvisningen noggrant.
	Denna symbol, placerad före en säkerhetskommentar, indikerar en slags försiktighetsåtgärd, varning eller fara. Att ignorera denna varning kan leda till en olycka. För att minska risken för skada, brand eller elstöt, följ alltid rekommendationerna nedan .
	Varning- Var noga med att bära handskar när du använder denna produkt.

### **WARNING!**

- 57) Spara denna handbok för säkerhetsvarningar och försiktighetsåtgärder. Manualen ger viktig information om hur man monterar, använder och underhåller denna produkt.
- 58) Vänligen hantera metallkanter försiktigt.
- 59) STÅ INTE på denna produkt eller använd den som en stege.
- 60) Ändra INTE denna produkt på något sätt som inte är avsett, eftersom detta kan orsaka produktskada eller personskada.
- 61) Montera alltid på en jämn yta.
- 62) Den maximala lastvikten för varje hylla är inte mer än 180 kg, jämnt fördelat.
- 63) Förvara de tyngsta föremålen på de nedre hyllorna.
- 64) Fäst enheten på väggen vid fyllning till kapacitet (beslag ingår ej).

## FÖRSIKTIGHETSÅTGÄRDER FÖR MONTERING

15. Vänligen montera produkten i strikt enlighet med instruktionerna. Felaktig montering kan vara farligt.
16. Vänligen använd skyddsglasögon och arbetshandskar ordentligt under monteringen.
3. Försök inte att montera produkten när du känner dig trött eller är påverkad av alkohol, droger eller medicin.
4. Bärförmåga och andra produktparametrar tillämpas endast på den korrekt och färdigmonterade produkten.
5. En hammare och ett par handskar kan också användas, förutsatt att en duk eller tråkloss placeras mellan hammarhuvudet och delarna.

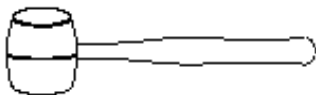

## ANVÄND FÖRSIKTIGHETSÅTGÄRDER

1. Den här produkten är inte en leksak. Tillåt inte barn att leka med eller få tillgång till detta föremål.
2. Kontrollera noggrant före användning. Använd den inte om delar lossnar eller skadas.
4. Använd endast på plana, jämna och hårda ytor.
5. Överskrid inte den angivna bärförmågan. Dra åt alla knoppar ordentligt innan du placerar vikter på den. Var uppmärksam på den dynamiska belastningen - bärighet! Plötsliga belastningsändringar kan tillfälligt orsaka överbelastning, vilket resulterar i produktfel.

## SPARA DESSA INSTRUKTIONER

## PRODUCT PARAMETERS





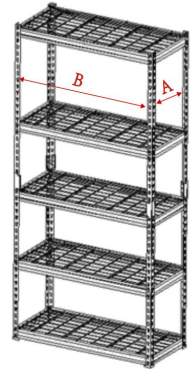







	1	2	3	4
Modell	6361QQUOV0	848E5KW7V0	040L9EDJV0	048EEK17V0
Produktstorlek / tum	16×36× 72	18 × 48 × 72	2 0 × 4 0 × 60	2 0 × 48 × 72
Dimension: A × B / tum	33. 5 × 13. 5	15.5 × 45. 5	17.5 × 37. 5	17.5 × 45. 5
Färg	Svart	Svart	Svart	Svart
Lager	5	5	4	5
Total lastgräns	2000 pund	2 5 00 pund	2 4 00 pund	3000 pund
belastningsgräns för varje lager	400 pund	5 00 pund	6 00 pund	6 00 pund

	5	6	7
Modell	448JA98TV0	8483M37BV0	040OGMXUV0
Produktstorlek	24 × 48 × 72 tum	18 × 48 × 72 tum	2 0 × 4 0 × 60 tum
Dimensionera: A × B / tum	21. 5 × 45. 5	15.5 × 45. 5	17.5 × 37. 5
Färg	Svart	Orange	Orange
Lager	5	5	4
Total lastgräns	3 000 pund	2 5 00 pund	2 4 00 pund
belastningsgräns ns för varje lager	6 00 pund	5 00 pund	6 00 pund











**Obs:** Tung föremål bör vara jämnt fördelade på hyllan för att undvika deformation på grund av koncentrerad belastning. Den maximala vikten för ett enda tungt föremål bör inte överstiga 30 kg.

## PART LIST

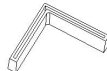
Del	Beskrivning	Bild	Del Antal			
			6361Q QUOV0	848E5 KW7V0	040L9 EDJV0	048EE K17V0
			16×36× 72 tum	18 × 48 × 72 tum	2 0 × 4 0 × 60 tum	2 0 × 48 × 72 tum
A	Stålnät		5	5	4	5
B	Upprätt stolpe		8	8	8	8
C	Översta hyllan kort balk		10	10	8	10
D	Översta hyllan lång balk		10	10	8	10
E	Fästen		4	4	4	4
F	Stolplock		16	16	16	16
G	Förstärkare		5	5	4	5
H	Krok		4	4	4	4
jag	Handskar		1 par	1 par	1 par	1 par
J	Tippskyddstillbehör		2 set	2 set	2 set	2 set
K	Anslutning		2	2	2	2
L	Hammare		1	1	1	1



Höjd på separerade hyllor		36 tum	36 tum	30 tum	36 tum
------------------------------	---	--------	--------	--------	--------

Del	Beskrivning	Bild	Del Antal		
			448JA 98TV0	8483M 37BV0	040OG MXUV0
			24 × 48 × 72 tum	18 × 48 × 72 tum	20 × 40 × 60 tum
A	Stålnät		5	5	4
B	Upprätt stolpe		8	8	8
C	Översta hyllan kort balk		10	10	8
D	Översta hyllan lång balk		10	10	8
E	Fästen		4	4	4
F	Stolplock		16	16	16
G	Förstärkare		5	5	4
H	Krok		4	4	4
jag	Handskar		1 par	1 par	1 par
J	Tippskyddstillbehör		2 set	2 set	2 set
K	Anslutning		2	2	2
L	Hammare		1	1	1
Höjd på separerade hyllor			36 tum	36 tum	30 tum

Översta hyllan balkknitar ha s en design som gör att stålnät kan sitta .

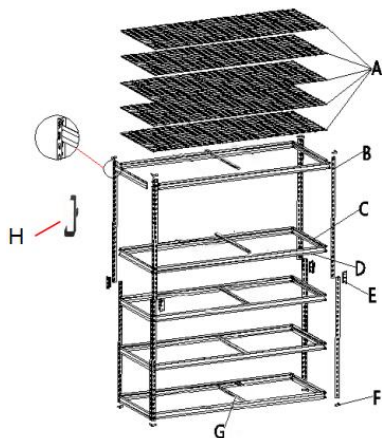

### Uppmärksamhet:

För ytterligare information om delarna som listas nedan, se monteringsdiagrammet i denna manual. Packa upp och separera alla delar på ett tydligt arbetsområde.

## ASSEMBLY STEP

### Steg 1: Montering av stolplock

1. Skjut in varje stolpe (B) i stolplocket (F) enligt bilden.
  2. Upprepa för alla fyra upprättstående stolparna.
- OBS: P ostkåpor är endast för upprättstående fötter.

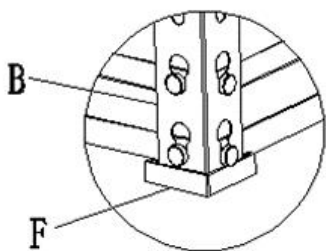

## Steg 2: Kort- och långstrålemontering

1. Rikta in korta balkar ( C ) och den långa balken s på översta hyllan ( D ) mot inriktade skåror mellan fyra upprättstående stolpar ( B ).
2. Väl på plats, knacka ordentligt med en gummiklubba.
3. Upprepa processen för motsatt sida, se till att båda ändarna är inställda på samma höjd.

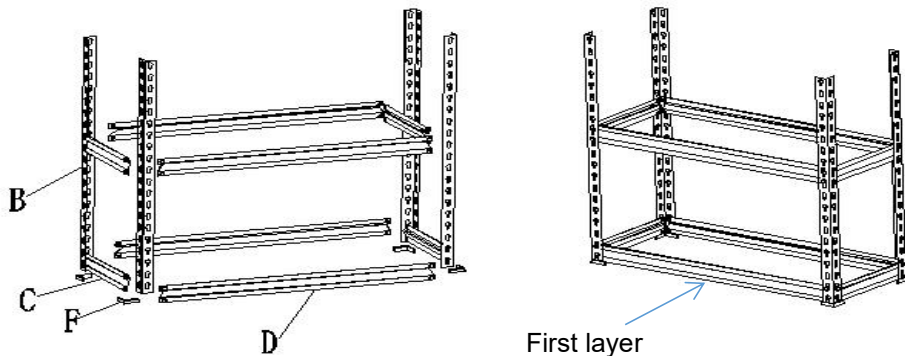

Notera:

- Håll det första lagret från marken inom 1 till 3 hålhöjder för att förhindra att kolonnerna deformeras och kollapsar på grund av för hög höjd.
- Se till att höjden på varje nivå är så enhetlig som möjligt.

## Steg 3: Montering av fästelement

1. Fäst fästena ( E ) överst på den upprättstående stolpen ( B ) och knacka ner till slutet.

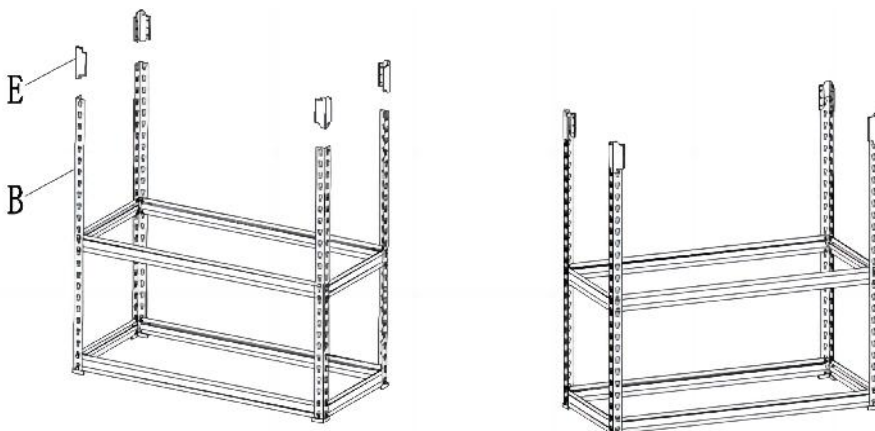

#### Steg 4: Installera den upprättstående stolpen

1. Botten av den upprättstående stolpen (B) fästs vid varje fäste (E), och knacka ner till slutet.

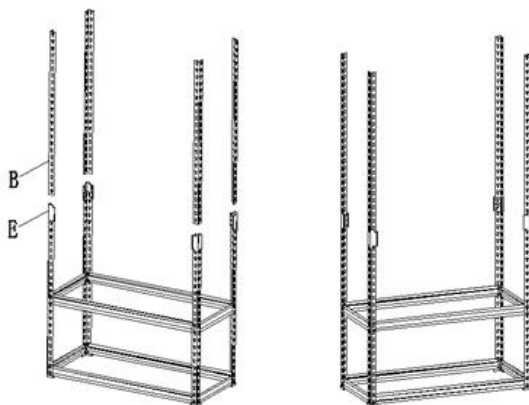

Steg 5: Installera den tredje, fjärde och femte översta hyllan lång balk(D) och kort balk(C); installationsmetoden är densamma som steg 2.



## Steg 6: Installera förstärkaren.

1. installera del G på varje del D.

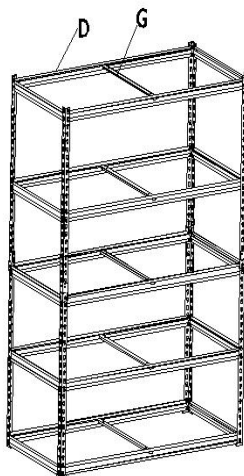

## Steg 7: Montering av den övre hyllan i stål nät

1. Sätt in den övre hyllan i stål nät (A) på de övre hyllstöden.
2. Se till att den sitter i jämnhöjd med toppen av enhetens ram.

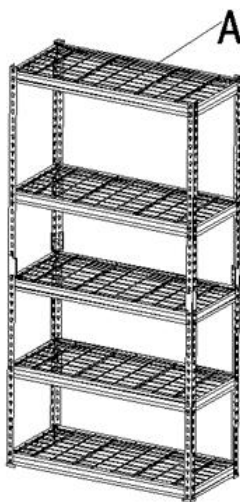

## Steg 8: Installera den övre limfoten

1. Skjut in varje stolpe (B) i stolplocket (F) enligt bilden.
2. Upprepa för alla fyra upprättstående stolparna.
3. Monteringen är nu klar och din enhet är redo att användas.
4. Tippskyddstillbehör (del J) kan användas för att fästa hyllan på väggen för att förhindra tippning.

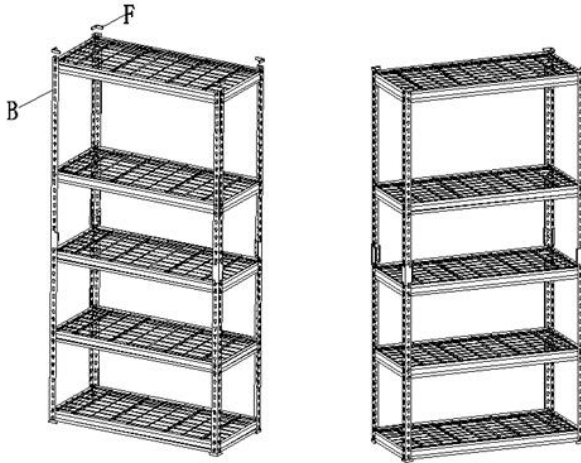

## Additional Functionality

15. Produkten kan delas upp i två hyllor . Du kan hitta höjden på varje hylla i tabellen över artikellistan .

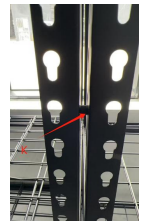
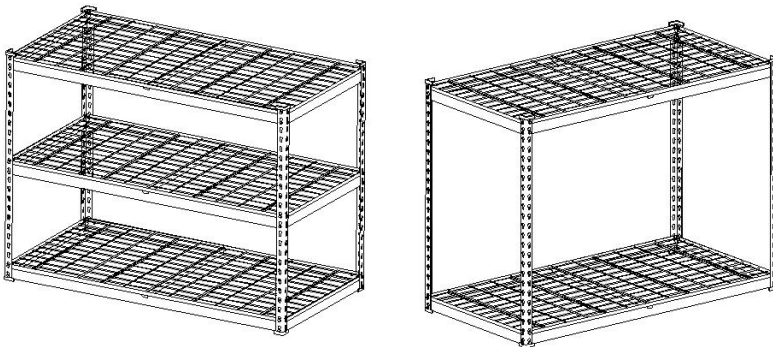

Notera: När de är delade för användning kan de två hyllorna kopplas ihop med del K as visas .

## 16. Konvertering av stålnät till sidopaneler:

Fäst näthyllan av stål på sidan av hyllenheten med hjälp av två (del H).

### 2.1 Lämplig användning:

Denna uppställning är idealisk för förvaring av vanliga lättviktsverktyg som måttband, tång och hammare.

### 2.2 Säkerhetsföreskrifter:

Använd inte för långa krokar för att hänga upp stora, tunga föremål för att förhindra potentiella skador från krokar eller fallande föremål.

Undvik att hänga tunga föremål som kan få hyllorna att välta.

### 2.3 Hook Allocation:

- Varje sidopanel ska stödjas av två krokar. Totalt fyra krokar tillhandahålls, lämpliga för två sidopaneler.
- På grund av inriktningsproblem med hålen, använd inte alla fyra krokarna för att hänga en enda sidopanel för att säkerställa att panelen kan installeras korrekt.



Hook



**Tillverkare:** Shanghaimuxinmuyeyouxiangongsi

**Address:** Shuangchenglu 803nong11hao1602A-1609shi, baoshanqu, shanghai 200000 CN.

**Importerad till AUS:** SIHAO PTY LTD, 1 ROKEVA STREETEASTWOOD NSW 2122 Australien

**Importerad till USA:** Sanven Technology Ltd., Suite 250, 9166 Anaheim Place, Rancho Cucamonga, CA 91730

<b>EC</b>	<b>REP</b>
-----------	------------

E-CrossStu GmbH  
Mainzer Landstr.69, 60329 Frankfurt am Main.

<b>UK</b>	<b>REP</b>
-----------	------------

YH CONSULTING LIMITED.  
C/O YH Consulting Limited Office 147, Centurion House,  
London Road, Staines-upon-Thames, Surrey, TW18 4AX



**VEVOR**<sup>®</sup>

**TOUGH TOOLS, HALF PRICE**

**Teknisk Support och e-garanticertifikat**

**[www.vevor.com/support](http://www.vevor.com/support)**