

VEVOR[®]

TOUGH TOOLS, HALF PRICE

Technical Support and E-Warranty Certificate www.vevor.com/support

ELECTRIC CONVEYOR TOASTER

MODEL:TT-150 TT-300 TT-450

We continue to be committed to provide you tools with competitive price.

"Save Half", "Half Price" or any other similar expressions used by us only represents an estimate of savings you might benefit from buying certain tools with us compared to the major top brands and does not necessarily mean to cover all categories of tools offered by us. You are kindly reminded to verify carefully when you are placing an order with us if you are actually saving half in comparison with the top major brands.

VEVOR®

TOUGH TOOLS, HALF PRICE

ELECTRIC CONVEYOR TOASTER

MODEL:TT-150 TT-300 TT-450

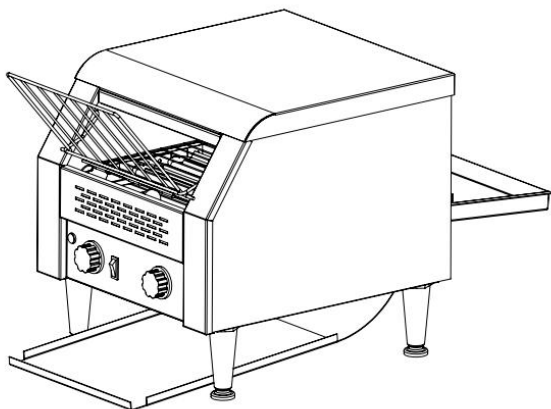

NEED HELP? CONTACT US!

Have product questions? Need technical support? Please feel free to contact us:

Technical Support and E-Warranty Certificate
www.vevor.com/support

This is the original instruction, please read all manual instructions carefully before operating. VEVOR reserves a clear interpretation of our user manual. The appearance of the product shall be subject to the product you received. Please forgive us that we won't inform you again if there are any technology or software updates on our product.

Specification of the toaster for different models:

Model	Region	Capacity (slices/per hour)	Size (mm)	Voltage, Frequency (V, Hz)	Power (w)
TT-150	USA	150-180	735*285*435	120, 60	1300
	EU	150-180	735*285*435	220-240, 50/60	1300
TT-300	USA	300-350	735*365*435	120, 60	1770
	EU	300-350	735*365*435	220-240, 50/60	2200
TT-450	USA	450-500	735*465*415	120, 60	1770
	EU	450-500	735*465*435	220-240, 50/60	2600

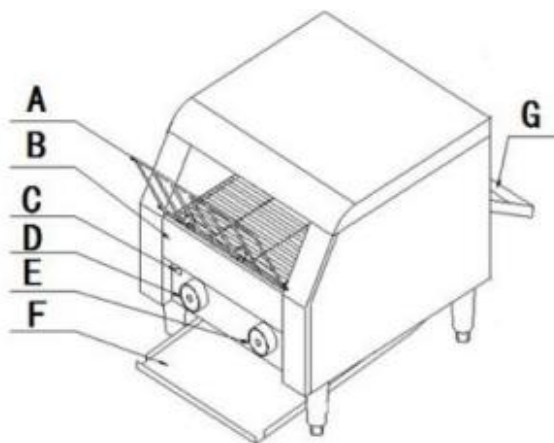

Name of the Components:

- A. Inputting net: Put bread on the net
- B. Trash tray: For putting trash during producing
- C. Power light(green): Machine is working well When power is on.
- D. Speed button: Adjusting speed of chain network
- E. Gear button: For adjusting temperature of the bread.
- F. Front side bread tray: Food sliding to front side after baking
- G. Back side bread tray: Food sliding to back side after baking

IMPORTANT SAFEGUARDS:

When using the electrical appliance, basic safety precautions should always be followed including the following. Read the instructions.

1. Please read the relevant instructions carefully before using the products.
2. This appliance can be used by children aged 8 years and above and persons with reduced physical, sensory, or mental capabilities or lack of experience and knowledge if they have been given supervision or instruction concerning using the appliance safely and understand the hazards. Children shall not play with the appliance. Cleaning and children shall not make user maintenance unless they are older than 8 and supervised.
3. Keep the appliance and cord out of reach of children less than 8 years.
3. If the supply cord is damaged, it must be replaced by the manufacturer, its service agent, or similarly qualified persons to avoid a hazard.
4. CAUTION: Hot surfaces. Do not touch hot surfaces. Use handles or knobs, Do not let the cord hang over the edge of a table or hot surface.
5. To protect against electric shock, do not immerse the cord, plugs, or housing in water or other liquid.
6. Please don't share the same power and other high-power appliances to prevent overloading and cause other hazards.
7. Never touch the plate or around while the products is working or just close because they are very hot, it could result in burn.
8. If you have a child near the machine, please take extra care to use the product, don't let children alone and place the product in baby hand can reach.
9. Don't allow the product to be used in unattended.
10. Please don't contact the power line with sharp objects and hot surfaces, avoiding damaging the power line.
11. Always check the power line and plug if damaged, please stop using it once there are signs of damage, then looking for professional worker to repair or replacement.
12. Don't damage, excessively bend, stretch, twist the power line and put heavy objects on the power line or nip the power line.

13. After using it, the thermostat knob should be turned to the "O" position, and then pull the plug from the socket, to avoid the occurrence of leakage or insulation aging shock.

14. The product should be installed in a dry, clean, well-ventilated location and placed in level position.

15. In order to ensure safety, the product must be grounded, and install the leakage switch, ensure personal safety, otherwise shall not be used.

16. Please pull off the plug and until the product is completely cooled before moving, check or clean up.

17. Don't insert or unplug the plug with wet hand, avoiding the risk of electric shock.

18. If a longer extension cable is used:

1) The marked electrical rating of the power cord group or extension cord should be at least as large as the electrical rating of the appliance;

2) The power cord shall be arranged so that it will not hang on the table or desktop to prevent children from unintentionally pulling or tripping.

19. If the appliance is grounded, the extension wire shall be grounded 3-core.

a) A short power-supply cord should be used to reduce the risk resulting from becoming entangled in or tripping over a longer cord.

b) Longer extension cords are available and may be used if care is exercised in their use.

c) If a longer extension cord is used:

1) The marked electrical rating of the cord set or extension cord should be at least as great as the electrical rating of the appliance; and

2) The cord should be arranged so that it will not drape over the countertop or table top where it can be pulled on by children or tripped over unintentionally.

If the appliance is of the grounded type, the extension cord should be a grounding-type 3-wire cord.

SAVE THESE INSTRUCTIONS

Note for the first time use:

1. Pls check if power of the machine comply with your local power or not before using the machine.
2. Power light turns on after connecting the power, Press D to “3” gear (note: Chain network will work faster if color is lighter). Pls turn the button to “bread” on right side of the machine, then heats will come from both upper and lower heating tubes, it will heat up gradually. Inside temperature of the toaster will reach 284°C in 12 minutes when bread has been put inside, then temperature will be constant at 284°C.
3. Machine should be pre-heat from 10-12 minutes, then bake 1-2 slices of bread for testing and check if color of the bread is OK or not, if color is too light, and you want darker color, pls adjust D more than “3” gear (note: Chain network will work slower if color of the bread is darker). After adjusting speed of the chain network, pls put the bread to chain network, bread will be moved inside of the machine when chain network is moving.
4. Bread will slide to Front side bread tray from firepot.
5. There is back side bread tray on back of the toaster, pls put the hook of the back tray down, the bread will slide to back side bread tray, pls put hook of the back tray up after getting the bread.
6. Pls adjust the gear to “BUNS” position, then only upper heating tube will work when baking steamed bread, pls adjust gear to “STBY” position when you only need warm up function.
7. Pls turn the button to “OFF” position and pull off plug.
8. Pls do not use the machine to heat up food with sugar or food will become liquid after heating, or it will damage the toaster.
9. If cable of toaster is broken, ONLY professional engineers can change it with specialized cable, pls be noted.

Care and Cleaning

1. Unplug the power cable and ensure that the product is cooled completely, then cleaning and collection.
2. Cleaning cooking surface with a soft cloth or sponge dampened in a mild detergent.
3. Please don't use wire brush, stiff brush or other corrosive liquids to clean it, avoiding damage the surface coating.

4. Never clean the product by sprinkling water and immersed in water.

Special Declaration

1. All the contents of this information have been checked carefully, if there is any misunderstanding because of printing and content, our company will reserve the right of final explanations.
2. If there is a technical improvement, we will compiled new specification into the Instructions, without prior notice. If the appearance of the product, color changes, please make the object as the standard.

CORRECT DISPOSAL



This product is subject to the provision of european Directive 2012/19/EU. The symbol showing a wheelie bin crossed through indicates that the product requires separate refuse collection in the European Union. This applies to the product and all accessories marked with this symbol. Products marked as such may not be discarded with normal domestic waste, but must be taken to a collection point for recycling electrical and electronic devices.

Manufacturer: Shanghaimuxinmuyeyouxiangongsi

Address: Shuangchenglu 803nong11hao1602A-1609shi, baoshanqu, shanghai 200000 CN.

Imported to AUS: SIHAO PTY LTD. 1 ROKEVA STREET EASTWOOD NSW 2122 Australia

Imported to USA: Sanven Technology Ltd. Suite 250, 9166 Anaheim Place, Rancho Cucamonga, CA 91730

UK	REP
-----------	------------

YH CONSULTING LIMITED. C/O YH Consulting Limited Office 147, Centurion House, London Road, Staines-upon-Thames, Surrey, TW18 4AX

EC	REP
-----------	------------

E-CrossStu GmbH
Mainzer Landstr.69,
60329 Frankfurt am Main.

VEVOR[®]

TOUGH TOOLS, HALF PRICE

Technical Support and E-Warranty Certificate

www.vevor.com/support