

VEVOR[®]

TOUGH TOOLS, HALF PRICE

Technical Support and E-Warranty Certificate

www.vevor.com/support

FISHING CART

MODEL: YK-400

We continue to be committed to provide you tools with competitive price.

"Save Half", "Half Price" or any other similar expressions used by us only represents an estimate of savings you might benefit from buying certain tools with us compared to the major top brands and does not necessarily mean to cover all categories of tools offered by us. You are kindly reminded to verify carefully when you are placing an order with us if you are actually saving half in comparison with the top major brands.

VEVOR[®]

TOUGH TOOLS, HALF PRICE

FISHING CART

MODEL: YK-400



NEED HELP? CONTACT US!

Have product questions? Need technical support? Please feel free to contact us:

Technical Support and E-Warranty Certificate
www.vevor.com/support

This is the original instruction, please read all manual instructions carefully before operating. VEVOR reserves a clear interpretation of our user manual. The appearance of the product shall be subject to the product you received. Please forgive us that we won't inform you again if there are any technology or software updates on our product.

SAFETY INSTRUCTIONS

1. Please check and confirm that the cart is intact and the tire pressure is normal before each use. Please inflate a little before using the wheels, and be careful not to over-inflate!
2. It is forbidden to carry people any condition.
3. It is forbidden to load articles on uneven and hilly terrains.
4. Overload is strictly prohibited.
5. Don't move too fast when passing pothole areas.

MODEL AND PARAMETERS

Model	YK-400
Max. Load	350lbs
Wheels	18inch(After Inflated size), inflatable, PU wheels*2
Fishing Rod Barrel	8
Frame Size (inside)	41.5 x 18 x 8inch
Material	Aluminium alloy
Color	White

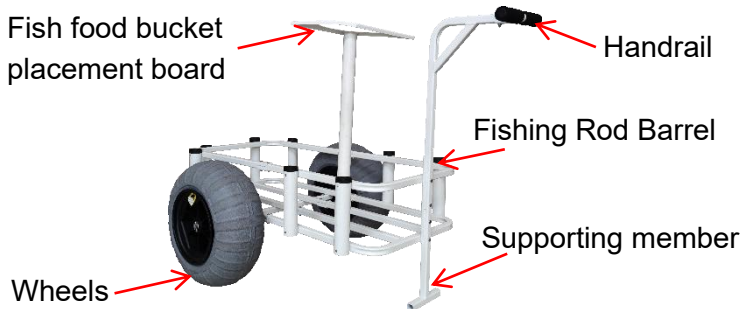

STRUCTURE DIAGRAM



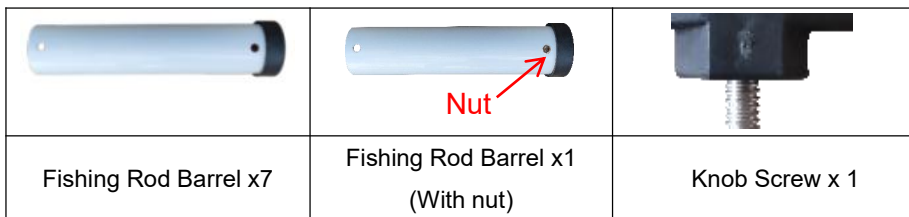
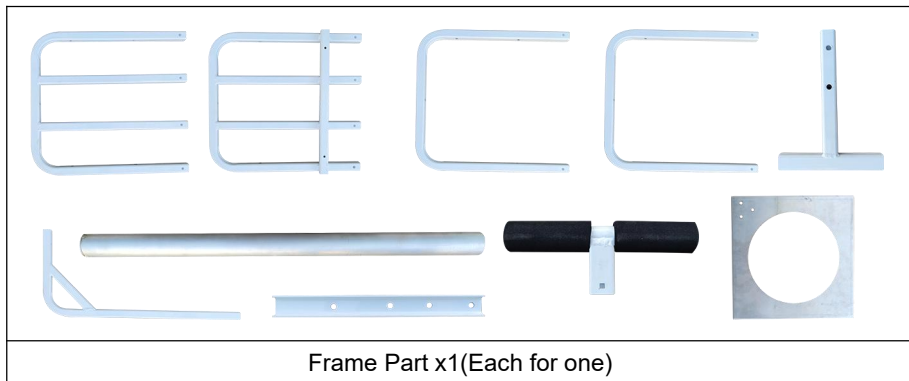

INSTALLATION



		
M6x50 Bolts x3 (Need two, one more)	M5x35 Bolts x14 (Need thirteen, one more)	M5x16 Bolts x19 (Need eighteen, one more)

		
M5x60 Bolts x2 (Need one, one more)	M6x25 Bolts x3 (Need two, one more)	Wheel jig cardboard x1

		
User Manual x1	Hand Pump x1	

Step 1: Connect the two lower frames together using the M5x35 bolts and the connection block.

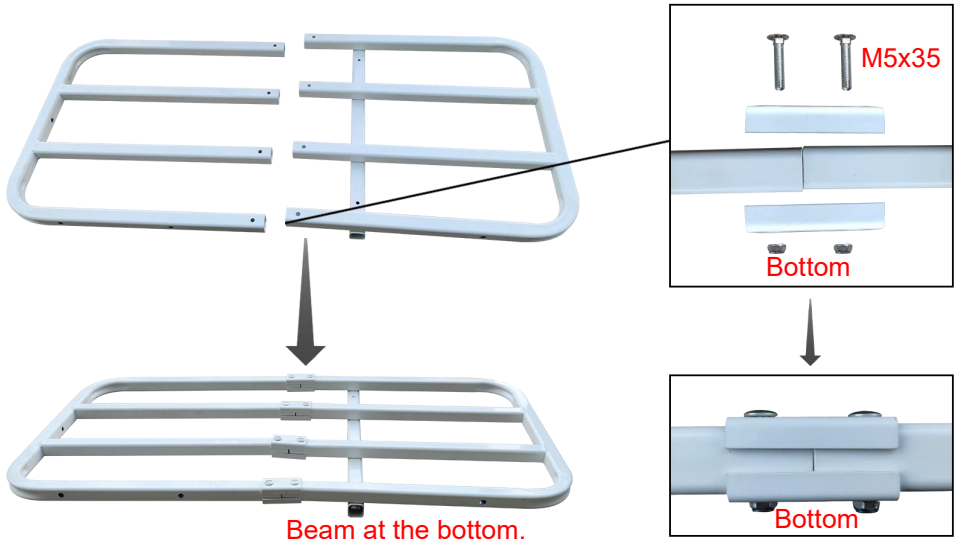

Step 2: Attach the upper frame in the same manner.

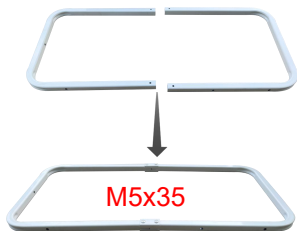

Step 3: Mounting the frame.

NOTE: The frames have pre-drilled holes for mounting the fishing barrels. The number of pre-drilled holes on the upper and lower frames on the same side should be the same.

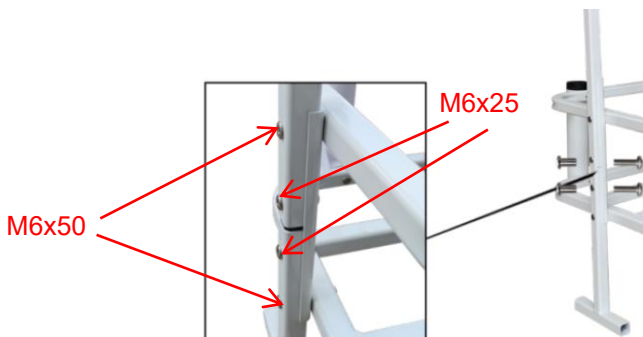
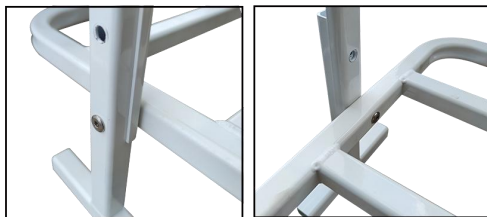

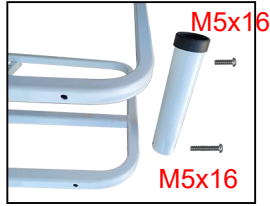

NOTE: M6X60 is required for the bottom bolt of the fishing rod barrel where the fish food bucket is placed.

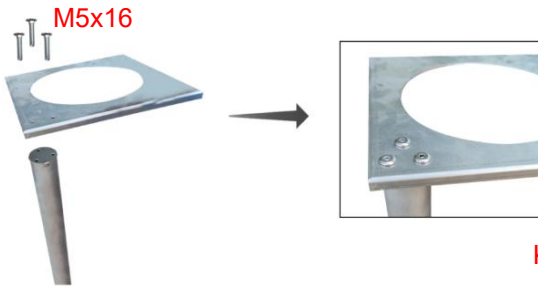

Tip: There is only one bucket with a nut, the upper end uses a Knob Screw and the lower end uses an M5X60 bolt, all other buckets are mounted with an M5X16 bolt.

Step 4: Install all rod barrels, then fix the handrail and the wheels.

NOTE: Please inflate the wheels before installation.



1 Take out the wheel and cardboard jig.



2 Insert the cardboard jig over the top of the wheel.



3 Insert tire valve into top valve of the hand pump. Bend the plastic handle forward to create a seal so that the tire will inflate more quickly.



4 Inflate until the tire fills the circumference of the cardboard jig.

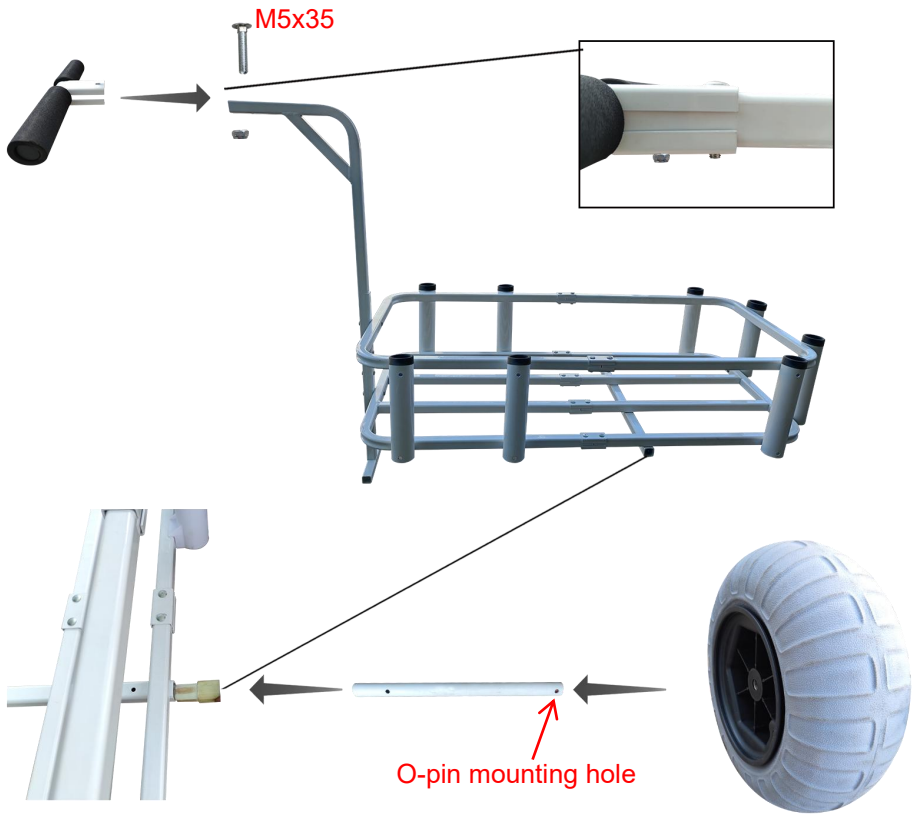

NOTE: Insert the plastic parts of the wheel axle into the ends of the bottom cross member of the frame, then insert the wheel axle, and finally install the wheel on it.

Step 5: Put in the washer first, then insert the O-pin.

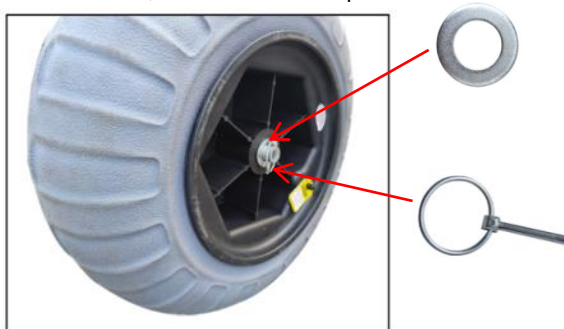

MAINTENANCE

1. Clean the surface after each use.
2. Please check and confirm that the cart is intact and the tire pressure is normal before each use.
3. Check that the bolts are tight.

Address: Baoshanqu Shuangchenglu 803long 11hao 1602A-1609shi
Shanghai

Imported to AUS: SIHAO PTY LTD, 1 ROKEVA STREETEASTWOOD
NSW 2122 Australia

Imported to USA: Sanven Technology Ltd, Suite 250, 9166 Anaheim
Place, Rancho Cucamonga, CA 91730



SHUNSHUN GmbH
Römeräcker 9 Z2021, 76351
Linkenheim-Hochstetten, Germany



Pooledas Group Ltd
Unit 5 Albert Edward House, The
Pavilions Preston, United Kingdom

Made In China

VEVOR[®]

TOUGH TOOLS, HALF PRICE

Technical Support and E-Warranty Certificate

www.vevor.com/support

VEVOR[®]

TOUGH TOOLS, HALF PRICE

Assistance technique et certificat de garantie électronique

www.vevor.com/support

CHARIOT DE PÊCHE

MODÈLE : YK-400

We continue to be committed to provide you tools with competitive price.

"Save Half", "Half Price" or any other similar expressions used by us only represents an estimate of savings you might benefit from buying certain tools with us compared to the major top brands and does not necessarily mean to cover all categories of tools offered by us. You are kindly reminded to verify carefully when you are placing an order with us if you are actually saving half in comparison with the top major brands.

VEVOR®

TOUGH TOOLS, HALF PRICE

FISHING CART

MODÈLE : YK-400



NEED HELP? CONTACT US!

Have product questions? Need technical support? Please feel free to contact us:

Technical Support and E-Warranty Certificate
www.vevor.com/support

This is the original instruction, please read all manual instructions carefully before operating. VEVOR reserves a clear interpretation of our user manual. The appearance of the product shall be subject to the product you received. Please forgive us that we won't inform you again if there are any technology or software updates on our product.

SAFETY INSTRUCTIONS

1. Veuillez vérifier et confirmer que le chariot est intact et que la pression des pneus est correcte.
normal avant chaque utilisation. Veuillez gonfler un peu avant d'utiliser les roues, et veillez à ne pas trop gonfler !
2. Il est interdit de transporter des personnes dans quelque condition que ce soit.
3. Il est interdit de charger des articles sur des terrains irréguliers et vallonnés.
4. La surcharge est strictement interdite.
5. Ne vous déplacez pas trop vite lorsque vous passez des zones de nids-de-poule.

MODEL AND PARAMETERS

Modèle	YK-400
Max. Charger	350 livres
roues	18 pouces (taille après gonflé) , gonflable, roues
Baril de canne à pêche	8
du cadre (intérieur)	41,5 x 18 x 8 pouces
Matériel	Alliage d'aluminium
Couleur	Blanc

STRUCTURE DIAGRAM

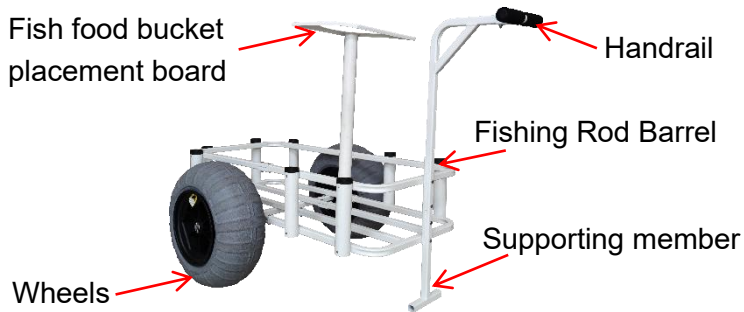

INSTALLATION

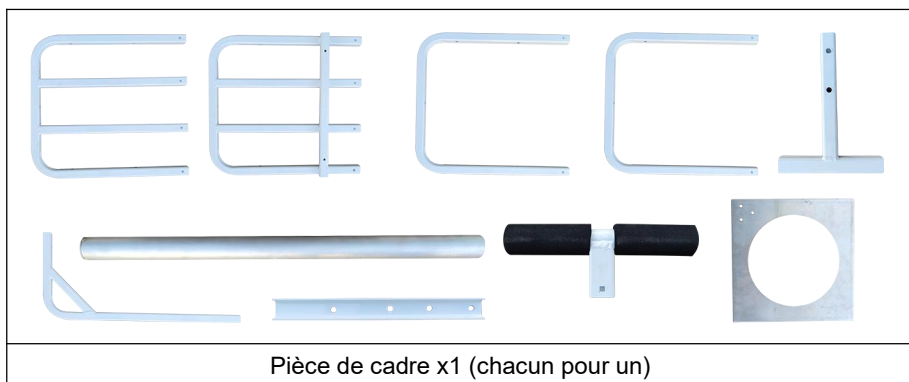



Connexion B lock x12	roues x2	Rondelle x2

Un essieu x 2	O- pin x2	Entretoise d'essieu x2

Baril de canne à pêche x	Baril de canne à pêche x	Vis de bouton x 1

7	1 (Avec écrou)	
---	-------------------	--

		
Clé hexagonale de 4 mm x 2	Clé hexagonale de 3 mm x 1	Clé _ x1 _

		
Boulons M6x50 x3 (Il en faut deux, un de plus)	Boulons M5x35 x14 (Il en faut treize, un de plus)	Boulons M5x16 x19 (Il en faut dix-huit, un de plus)

		
Boulons M5x60 x2 (J'en ai besoin d'un, un de plus)	Boulons M6x25 x3 (Il en faut deux, un de plus)	Carton de gabarit de roue x 1

		
Manuel d'utilisation x1	Pompe à main x1	

Étape 1: Reliez les deux cadres inférieurs ensemble à l'aide des boulons M5x35 et du bloc de connexion.

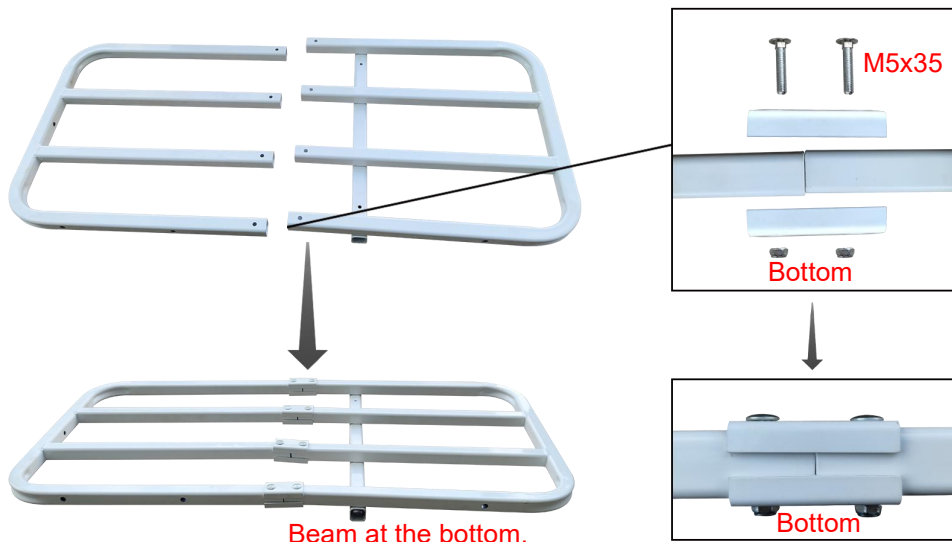

Étape 2: Fixez le cadre supérieur de la même manière.

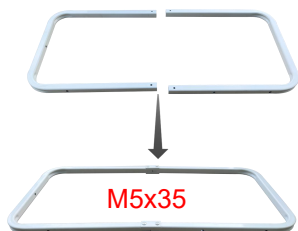

Étape 3: Montage du cadre .

REMARQUE : Les cadres comportent des trous pré-perçés pour le montage des barils de pêche. Le nombre de trous pré-perçés sur les cadres supérieur et inférieur du même côté doit être le même.



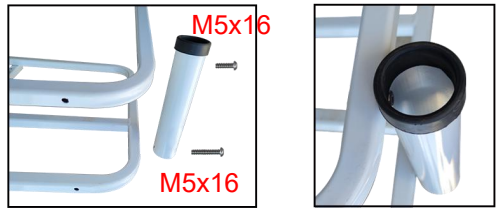
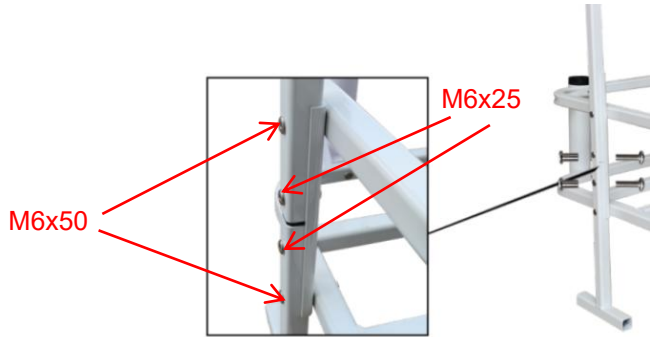
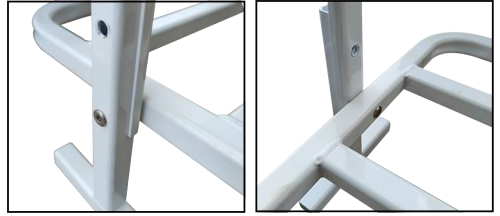

REMARQUE : M6X60 est requis pour le boulon inférieur du canon de la canne à pêche où est placé le seau de nourriture pour poisson .

M5x16

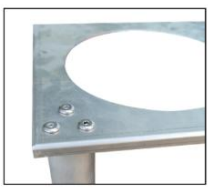

Tip: There is only one bucket with a nut, the upper end uses a Knob Screw and the lower end uses an M5X60 bolt, all other buckets are mounted with an M5X16 bolt.

Étape 4: Installez tous les barillets de tige, puis fixez la main courante et les roues .

REMARQUE : Veuillez gonfler les roues avant l'installation.



1 Take out the wheel and cardboard jig.



2 Insert the cardboard jig over the top of the wheel.



3 Insert tire valve into top valve of the hand pump. Bend the plastic handle forward to create a seal so that the tire will inflate more quickly.



4 Inflate until the tire fills the circumference of the cardboard jig.

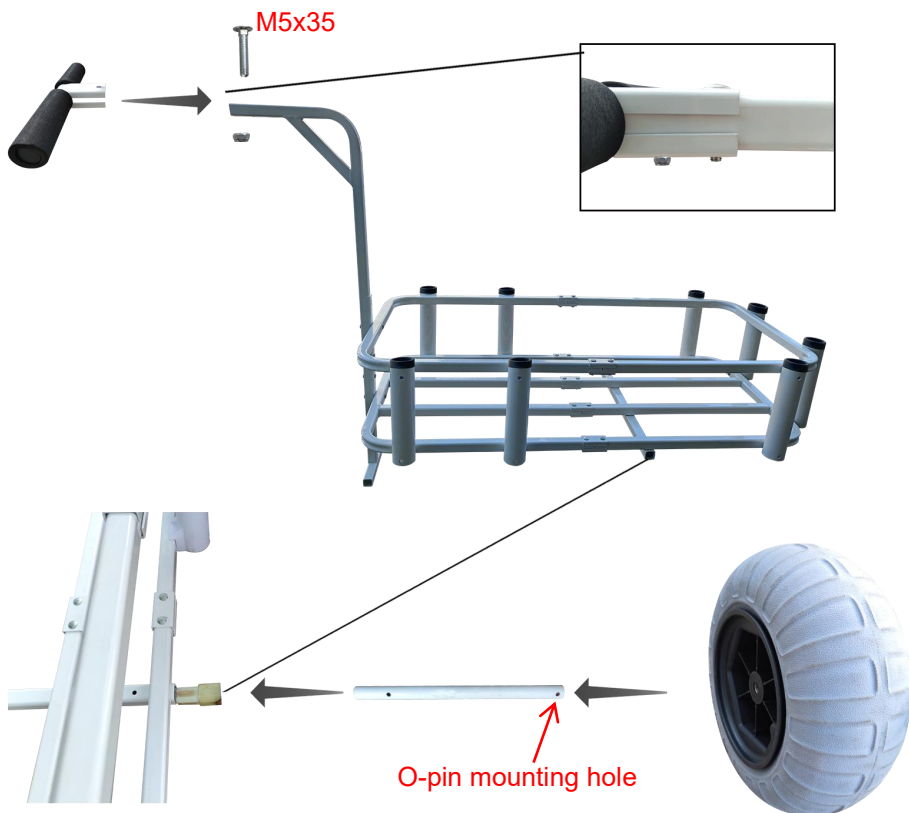

REMARQUE : Insérez les pièces en plastique de l'axe de roue dans les extrémités de la traverse inférieure du cadre, puis insérez l'axe de roue et enfin installez la roue dessus.

Étape 5 : Mettez d'abord la rondelle , puis insérez la goupille O.

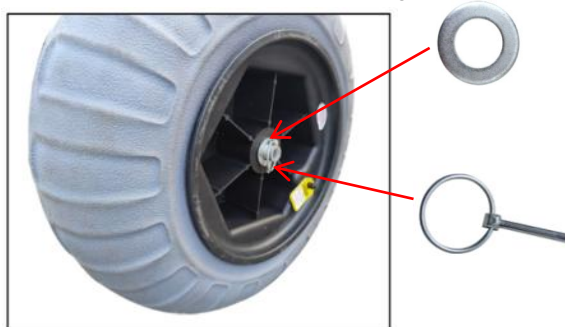

MAINTENANCE

4. Nettoyez la surface après chaque utilisation.
5. Veuillez vérifier et confirmer que le chariot est intact et que la pression des pneus est correcte.
normal avant chaque utilisation.
6. Vérifiez que les boulons sont serrés .

Adresse : Baoshanqu Shuangchenglu 803long 11hao 1602A-1609shi
Shanghai

Importé en Australie : SIHAO PTY LTD, 1 ROKEVA STREETASTWOOD
NSW 2122 Australie

Importé aux États-Unis : Sanven Technology Ltd, Suite 250, 9166
Anaheim Place, Rancho Cucamonga, CA 91730



SHUNSHUN GmbH
Römeräcker 9 Z2021, 76351
Linkenheim-Hochstetten, Germany



Pooledas Group Ltd
Unit 5 Albert Edward House, The
Pavilions Preston, United Kingdom

Fabriqué en Chine

VEVOR[®]

TOUGH TOOLS, HALF PRICE

Technique Assistance et certificat de garantie électronique

www.vevor.com/support

VEVOR[®]

TOUGH TOOLS, HALF PRICE

Zertifikat für technischen Support und E-Garantie

www.vevor.com/support

ANGELWAGEN

MODELL: YK-400

We continue to be committed to provide you tools with competitive price.

"Save Half", "Half Price" or any other similar expressions used by us only represents an estimate of savings you might benefit from buying certain tools with us compared to the major top brands and does not necessarily mean to cover all categories of tools offered by us. You are kindly reminded to verify carefully when you are placing an order with us if you are actually saving half in comparison with the top major brands.

VEVOR®

TOUGH TOOLS, HALF PRICE

FISHING CART

MODELL: YK-400



NEED HELP? CONTACT US!

Have product questions? Need technical support? Please feel free to contact us:

Technical Support and E-Warranty Certificate
www.vevor.com/support

This is the original instruction, please read all manual instructions carefully before operating. VEVOR reserves a clear interpretation of our user manual. The appearance of the product shall be subject to the product you received. Please forgive us that we won't inform you again if there are any technology or software updates on our product.

SAFETY INSTRUCTIONS

1. Bitte überprüfen und bestätigen Sie, dass der Wagen intakt ist und der Reifendruck stimmt normal vor jedem Gebrauch. Bitte pumpen Sie die Räder ein wenig auf, bevor Sie sie verwenden, und achten Sie darauf, nicht zu viel aufzupumpen!
2. Es ist verboten, Personen jeglicher Art zu befördern.
3. Das Verladen von Gegenständen auf unebenem und hügeligem Gelände ist verboten.
4. Überlastung ist strengstens untersagt.
5. Fahren Sie nicht zu schnell, wenn Sie an Schlaglochstellen vorbeifahren.

MODEL AND PARAMETERS

Modell	YK-400
Max. Belastung	350 Pfund
Räder	18 Zoll (Größe nach dem Aufblasen) , aufblasbar,
Angelrutenfass	8
Rahmengröße (innen)	41,5 x 18 x 8 Zoll
Material	Aluminiumlegierung
Farbe	Weiß

STRUCTURE DIAGRAM

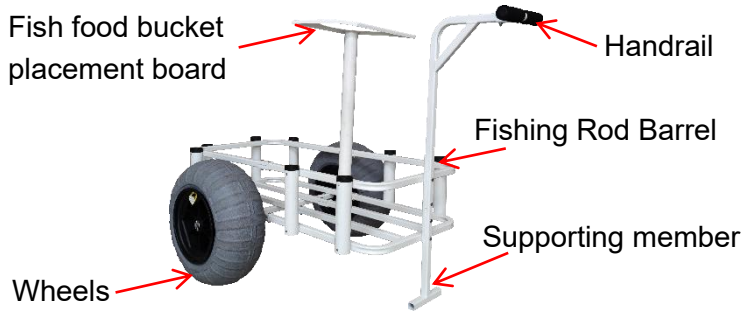



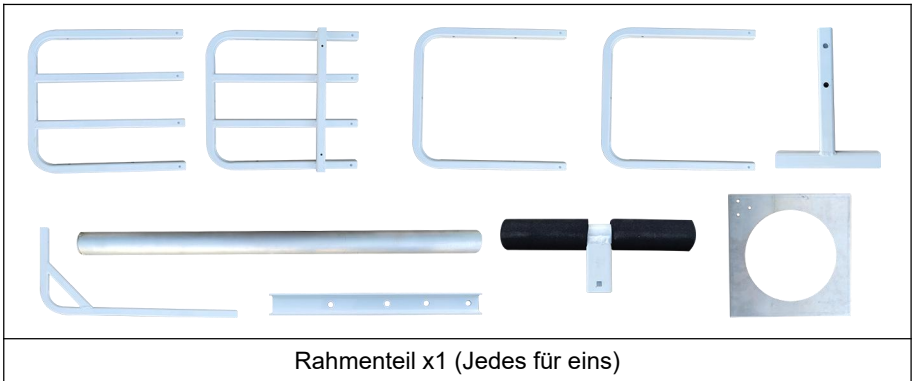







INSTALLATION



Anschluss B - Sperre x12	Räder x2	Unterlegscheibe x2

Eine xle x 2	O- Pin x2	Achsabstandshalter x2

Angelrutenfass x 7	Angelrutenfass x 1	Knopfschraube x 1

	(Mit Mutter)	
		
4-mm- Inbusschlüssel x 2	3 mm Sechskantschlüssel x 1	Schraubenschlüssel _ x 1
		
M6x50 Schrauben x3 (Brauchen zwei, noch eins)	M5x35 Schrauben x14 (Brauchen dreizehn, noch eins)	M5x16 Schrauben x19 (Brauchen achtzehn, noch eins)
		
M5x60 Schrauben x2 (Brauche noch eins, noch eins)	M6x25 Schrauben x3 (Brauchen zwei, noch eins)	Radlehre aus Pappe x 1
		
Benutzerhandbuch x1	Handpumpe x1	

Schritt 1: Verbinden Sie die beiden unteren Rahmen mit den M5x35-Schrauben und dem Verbindungsblock miteinander.

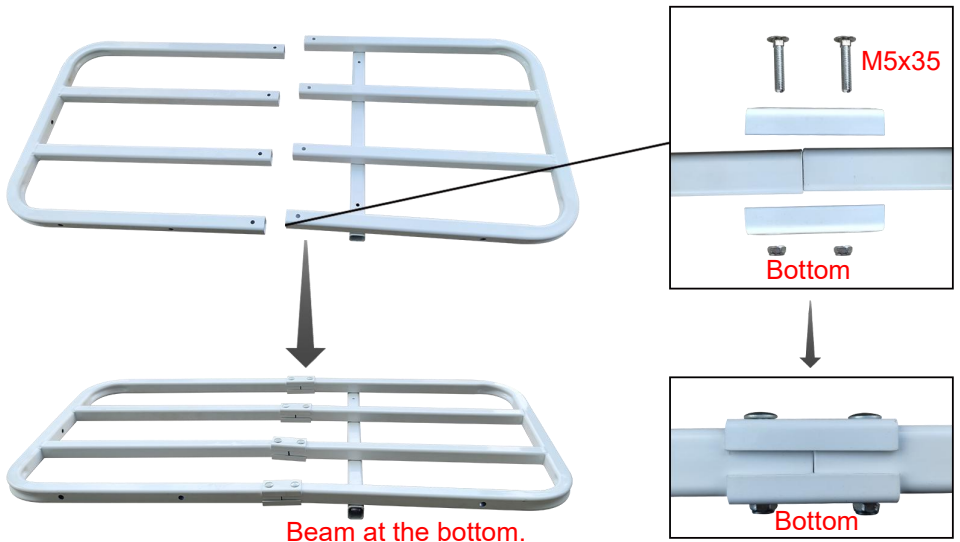

Schritt 2: Befestigen Sie den oberen Rahmen auf die gleiche Weise.

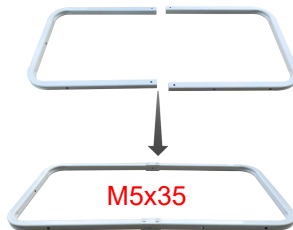

Schritt 3: Montage des Rahmens .

HINWEIS: Die Rahmen verfügen über vorgebohrte Löcher zur Montage der Angelfässer. Die Anzahl der vorgebohrten Löcher am oberen und unteren Rahmen auf derselben Seite sollte gleich sein.



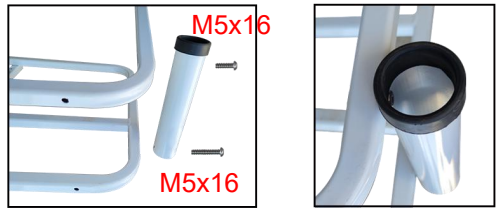
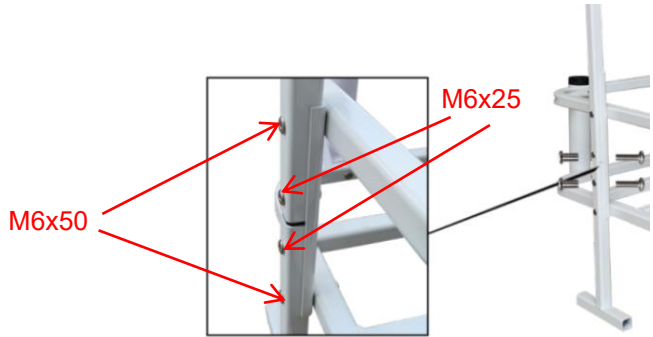
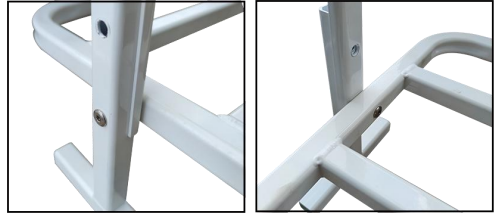

HINWEIS: Für die untere Schraube des Angelrutenrohrs, wo der Fischfuttereimer platziert wird, ist M6X60 erforderlich .

M5x16

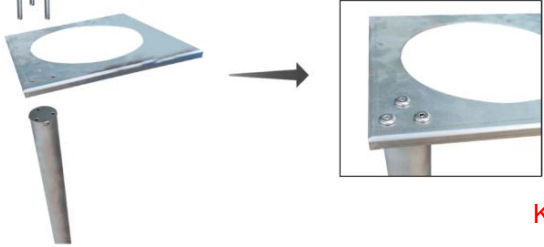

Knob Screw

M5x60



Tip: There is only one bucket with a nut, the upper end uses a Knob Screw and the lower end uses an M5X60 bolt, all other buckets are mounted with an M5X16 bolt.

Schritt 4: Montieren Sie alle Stangenrohre und befestigen Sie dann den Handlauf und die Räder .

HINWEIS: Bitte pumpen Sie die Räder vor der Montage auf.



1 Take out the wheel and cardboard jig.



2 Insert the cardboard jig over the top of the wheel.



3 Insert tire valve into top valve of the hand pump. Bend the plastic handle forward to create a seal so that the tire will inflate more quickly.



4 Inflate until the tire fills the circumference of the cardboard jig.

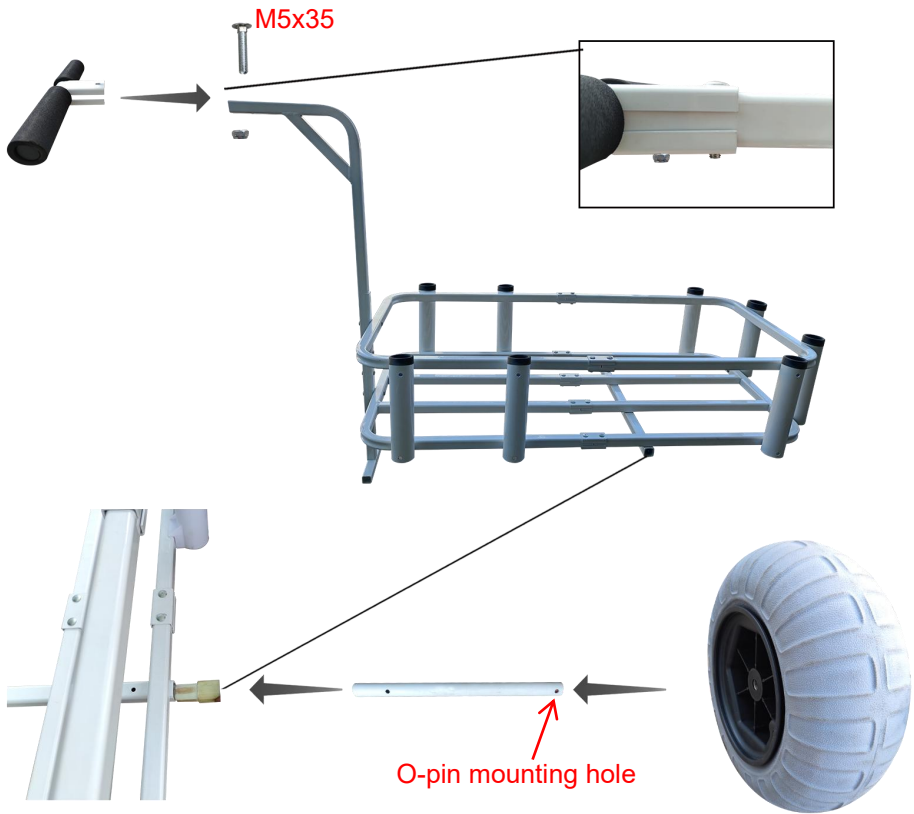

HINWEIS: Stecken Sie die Kunststoffteile der Radachse in die Enden des unteren Querträgers des Rahmens, setzen Sie dann die Radachse ein und montieren Sie schließlich das Rad darauf.

Schritt 5: Setzen Sie zuerst die Unterlegscheibe ein und setzen Sie dann den O- Stift ein.

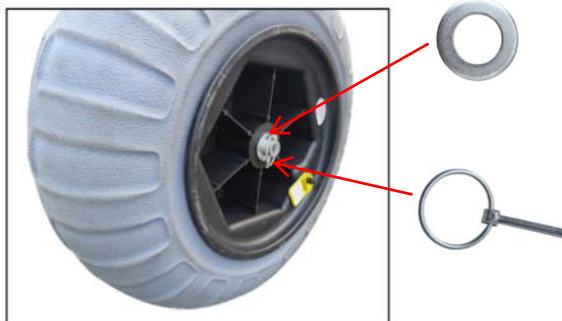

MAINTENANCE

7. Reinigen Sie die Oberfläche nach jedem Gebrauch.
8. Bitte überprüfen und bestätigen Sie, dass der Wagen intakt ist und der Reifendruck stimmt normal vor jedem Gebrauch.
9. Überprüfen Sie, ob die Schrauben fest sitzen .

Adresse: Baoshanqu Shuangchenglu 803long 11hao 1602A-1609shi
Shanghai

Importiert nach AUS: SIHAO PTY LTD, 1 ROKEVA STREETEASTWOOD
NSW 2122 Australien

In die USA importiert: Sanven Technology Ltd, Suite 250, 9166 Anaheim
Place, Rancho Cucamonga, CA 91730

EC	REP	SHUNSHUN GmbH Römeräcker 9 Z2021, 76351 Linkenheim-Hochstetten, Germany
-----------	------------	---

UK	REP	Pooledas Group Ltd Unit 5 Albert Edward House, The Pavilions Preston, United Kingdom
-----------	------------	--

In China hergestellt

VEVOR[®]

TOUGH TOOLS, HALF PRICE

Technisch Support- und E-Garantiezertifikat

www.vevor.com/support

VEVOR[®]

TOUGH TOOLS, HALF PRICE

Supporto tecnico e certificato di garanzia elettronica

www.vevor.com/support

CARRELLO DA PESCA

MODELLO: YK-400

We continue to be committed to provide you tools with competitive price.

"Save Half", "Half Price" or any other similar expressions used by us only represents an estimate of savings you might benefit from buying certain tools with us compared to the major top brands and does not necessarily mean to cover all categories of tools offered by us. You are kindly reminded to verify carefully when you are placing an order with us if you are actually saving half in comparison with the top major brands.

VEVOR[®]

TOUGH TOOLS, HALF PRICE

FISHING CART

MODELLO: YK-400



NEED HELP? CONTACT US!

Have product questions? Need technical support? Please feel free to contact us:

Technical Support and E-Warranty Certificate
www.vevor.com/support

This is the original instruction, please read all manual instructions carefully before operating. VEVOR reserves a clear interpretation of our user manual. The appearance of the product shall be subject to the product you received. Please forgive us that we won't inform you again if there are any technology or software updates on our product.

SAFETY INSTRUCTIONS

1. Controllare e confermare che il carrello sia integro e che la pressione dei pneumatici lo sia normale prima di ogni utilizzo. Si prega di gonfiare un po' prima di utilizzare le ruote e fare attenzione a non gonfiare eccessivamente!
2. È vietato trasportare persone in qualsiasi condizione.
3. È vietato caricare articoli su terreni sconnessi e collinari.
4. Il sovraccarico è severamente vietato.
5. Non muoverti troppo velocemente quando attraversi aree con buche.

MODEL AND PARAMETERS

Modello	YK-400
Massimo. Carico	350 libbre
Ruote	18 pollici (dopo la dimensione gonfiata) , ruote
Canna da pesca	8
Dimensioni cornice (interna)	41,5 x 18 x 8 pollici
Materiale	Lega di alluminio
Colore	Bianco

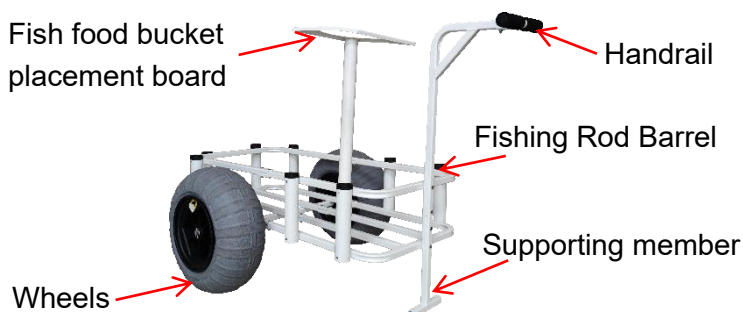

STRUCTURE DIAGRAM



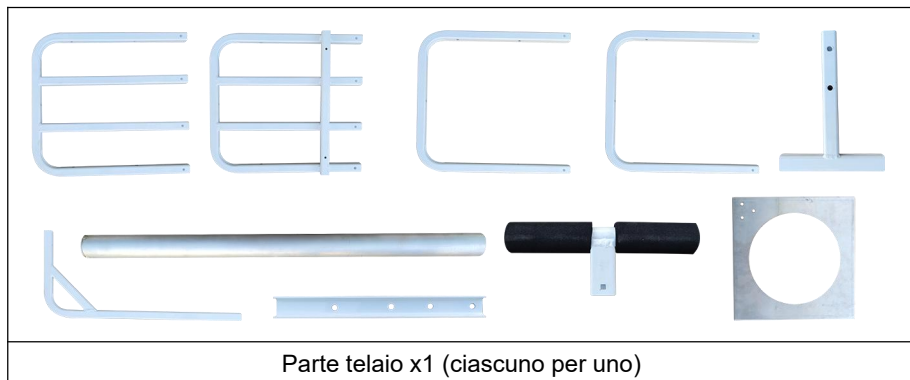

INSTALLATION



		
Blocco connessione B x12	ruotex2	Rondella x2

		
Un asse x 2	O- pin x2	Distanziatore dell'asse x2

		
Canna da pesca x 7	Canna da pesca x 1 (Con dado)	Vite manopola x 1

		
---	---	---

Chiave esagonale da 4 mm x 2	Chiave esagonale da 3 mm x 1	W rench x1 _
------------------------------	------------------------------	--------------

		
Bulloni M6x50x3 (Ne servono due, uno in più)	Bulloni M5x35 x14 (Ne servono tredici, uno in più)	Bulloni M5x16x19 (Ne servono diciotto, uno in più)

		
Bulloni M5x60x2 (Ne serve uno, uno in più)	Bulloni M6x25x3 (Ne servono due, uno in più)	Cartone per maschera per ruote x 1

		
Manuale utente x1	Pompa a mano x1	

Passo 1: Collegare insieme i due telai inferiori utilizzando i bulloni M5x35 e il blocco di connessione.

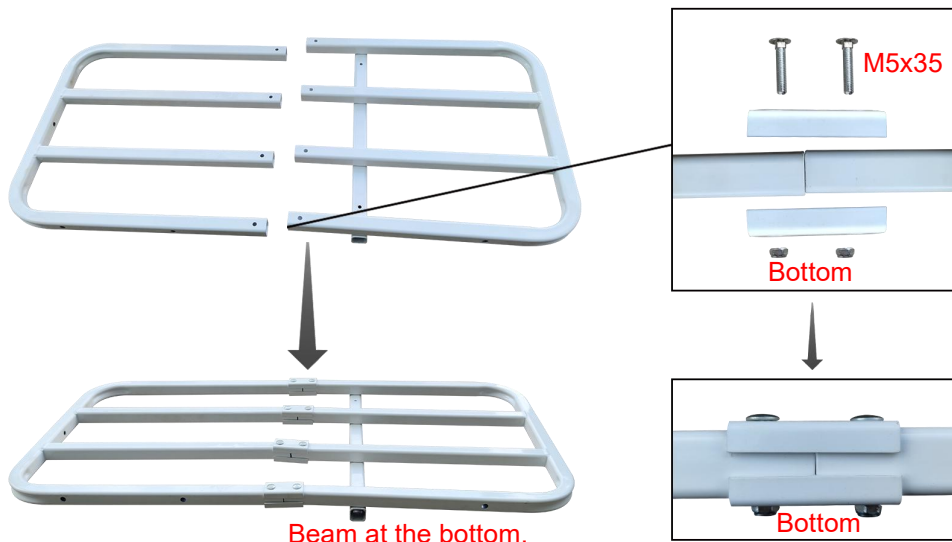

Passo 2: Fissare il telaio superiore allo stesso modo.

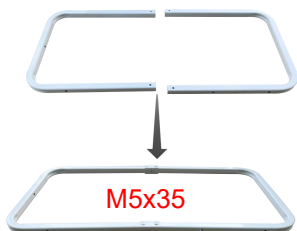

Passaggio 3: Montaggio del telaio .

NOTA: i telai sono dotati di fori predisposti per il montaggio delle canne da pesca. Il numero di fori preforati sui telai superiore e inferiore sullo stesso lato deve essere lo stesso.



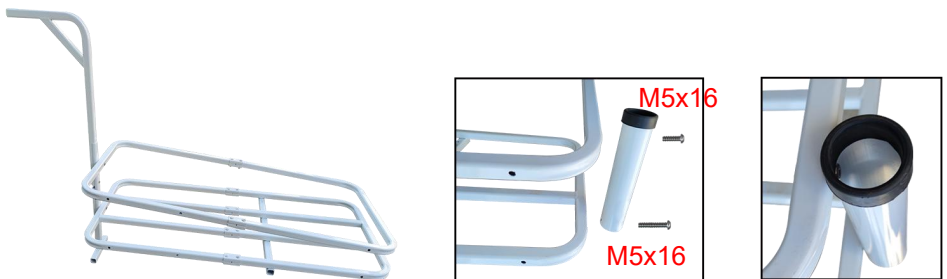
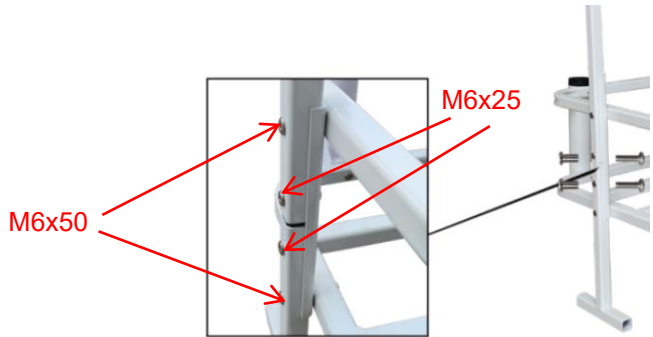
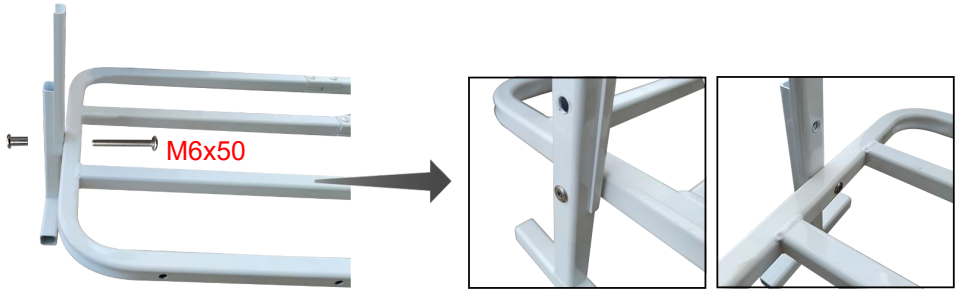

NOTA: è necessario M6X60 per il bullone inferiore del barile della canna da pesca dove è posizionato il secchio del cibo per pesci .

M5x16

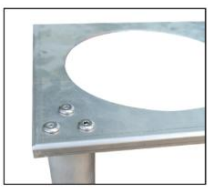

Tip: There is only one bucket with a nut, the upper end uses a Knob Screw and the lower end uses an M5X60 bolt, all other buckets are mounted with an M5X16 bolt.

Passaggio 4: Installare tutti i cilindri delle aste, quindi fissare il corrimano e le ruote .

NOTA: gonfiare le ruote prima dell'installazione.



1 Take out the wheel and cardboard jig.



2 Insert the cardboard jig over the top of the wheel.



3 Insert tire valve into top valve of the hand pump. Bend the plastic handle forward to create a seal so that the tire will inflate more quickly.



4 Inflate until the tire fills the circumference of the cardboard jig.

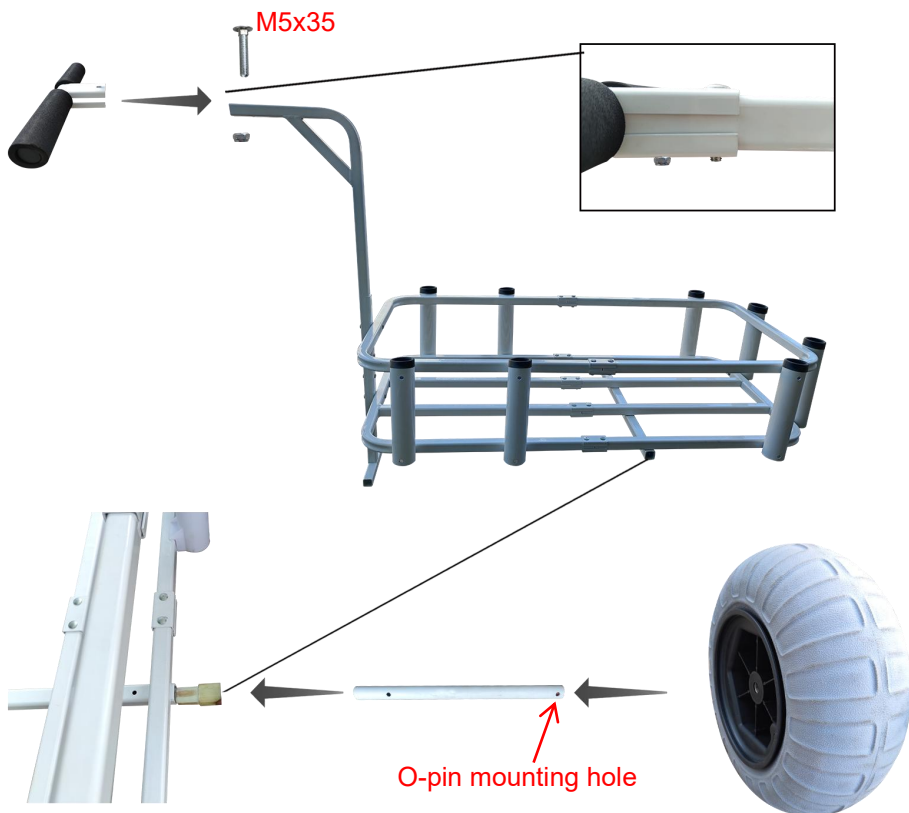

NOTA: inserire le parti in plastica dell'asse della ruota nelle estremità della traversa inferiore del telaio, quindi inserire l'asse della ruota e infine installare la ruota su di esso.

Passaggio 5: Inserire prima la rondella , quindi inserire l' O- pin.

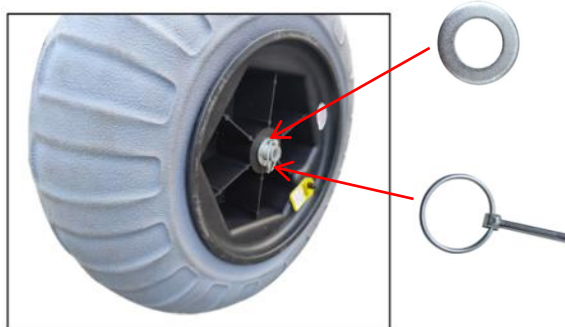

MAINTENANCE

10. Pulire la superficie dopo ogni utilizzo.
11. Si prega di controllare e confermare che il carrello sia integro e che la pressione dei pneumatici lo sia normale prima di ogni utilizzo.
12. Controllare che i bulloni siano serrati .

Indirizzo: Baoshanqu Shuangchenglu 803long 11hao 1602A-1609shi
Shanghai

Importato in AUS: SIHAO PTY LTD, 1 ROKEVA STREETEASTWOOD
NSW 2122 Australia

Importato negli Stati Uniti: Sanven Technology Ltd, Suite 250, 9166
Anaheim Place, Rancho Cucamonga, CA 91730



SHUNSHUN GmbH
Römeräcker 9 Z2021, 76351
Linkenheim-Hochstetten, Germany



Pooledas Group Ltd
Unit 5 Albert Edward House, The
Pavilions Preston, United Kingdom

Made in China

VEVOR[®]

TOUGH TOOLS, HALF PRICE

Tecnico Supporto e certificato di garanzia elettronica

www.vevor.com/support

VEVOR[®]

TOUGH TOOLS, HALF PRICE

Soporte técnico y certificado de garantía electrónica

www.vevor.com/support

CARRO DE PESCA

MODELO: YK-400

We continue to be committed to provide you tools with competitive price.

"Save Half", "Half Price" or any other similar expressions used by us only represents an estimate of savings you might benefit from buying certain tools with us compared to the major top brands and does not necessarily mean to cover all categories of tools offered by us. You are kindly reminded to verify carefully when you are placing an order with us if you are actually saving half in comparison with the top major brands.

VEVOR[®]

TOUGH TOOLS, HALF PRICE

FISHING CART

MODELO: YK-400



NEED HELP? CONTACT US!

Have product questions? Need technical support? Please feel free to contact us:

Technical Support and E-Warranty Certificate
www.vevor.com/support

This is the original instruction, please read all manual instructions carefully before operating. VEVOR reserves a clear interpretation of our user manual. The appearance of the product shall be subject to the product you received. Please forgive us that we won't inform you again if there are any technology or software updates on our product.

SAFETY INSTRUCTIONS

1. Verifique y confirme que el carrito esté intacto y que la presión de los neumáticos sea normal antes de cada uso. Infle un poco antes de usar las ruedas y tenga cuidado de no inflar demasiado.
2. Está prohibido el transporte de personas en cualquier condición.
3. Está prohibido cargar artículos en terrenos irregulares y montañosos.
4. La sobrecarga está estrictamente prohibida.
5. No se mueva demasiado rápido al pasar por zonas con baches.

MODEL AND PARAMETERS

Modelo	YK-400
Máx. Carga	350 libras
Ruedas	18 pulgadas (después del tamaño inflado) ,
Barril de caña de	8
Tamaño del marco (interior)	41,5 x 18 x 8 pulgadas
Material	Aleación de aluminio
Color	Blanco

STRUCTURE DIAGRAM

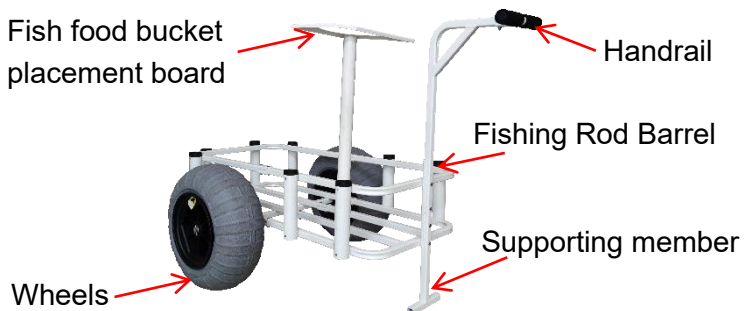

INSTALLATION

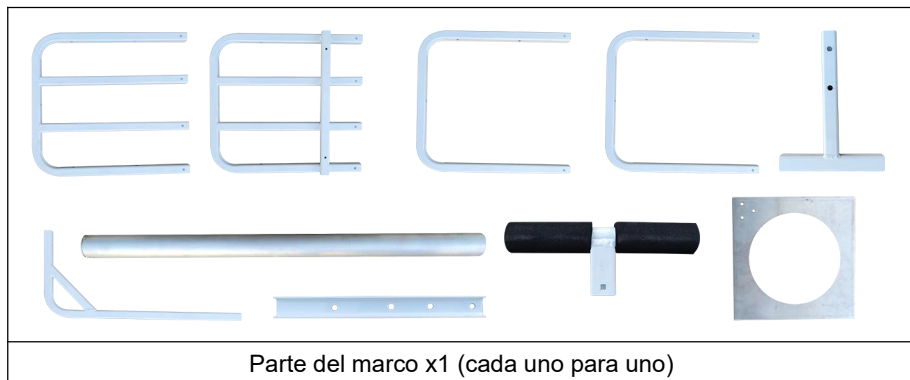

Bloqueo de conexión x12	ruedas x2	Lavadora x2

Un eje x 2	O- pin x2	Espaciador del eje x2

Barril de caña de pescar x 7	Barril de caña de pescar x 1 (Con tuerca)	Tornillo de perilla x 1

2 llaves hexagonales de	1 llave hexagonal de 3	llave inglesa x1 _

4 mm .	mm .	
--------	------	--

		
Pernos M6x50 x3 (Necesito dos, uno más)	Pernos M5x35 x14 (Necesita trece, uno más)	Pernos M5x16 x19 (Necesita dieciocho, uno más)

		
Pernos M5x60 x2 (Necesito uno, uno más)	Pernos M6x25 x3 (Necesito dos, uno más)	Cartón de plantilla de rueda x 1

		
Manual de usuario x1	Bomba de mano x1	

Paso 1: Conecte los dos marcos inferiores entre sí utilizando los pernos M5x35 y el bloque de conexión.

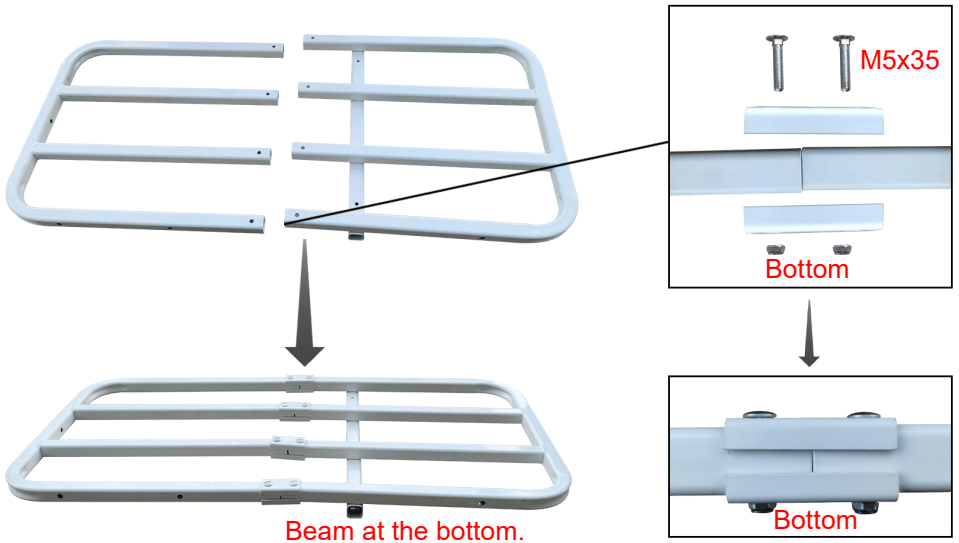

Paso 2: Fije el marco superior de la misma manera.

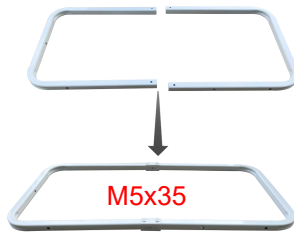

Paso 3: Montaje del marco .

NOTA: Los marcos tienen orificios pretaladrados para montar los barriles de pesca. El número de orificios previamente perforados en los marcos superior e inferior del mismo lado debe ser el mismo.



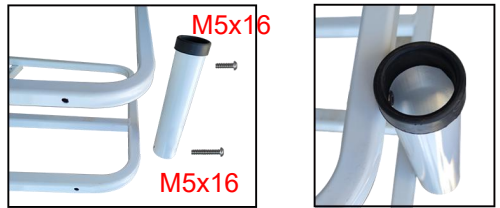
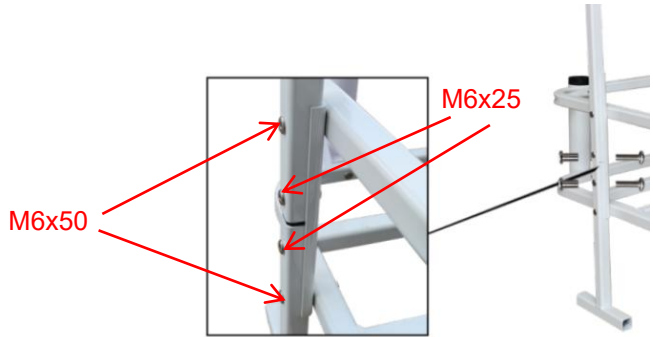
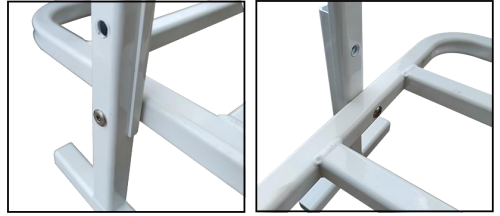

NOTA: Se requiere M6X60 para el perno inferior del barril de la caña de pescar donde se coloca el cubo de comida para peces .

M5x16

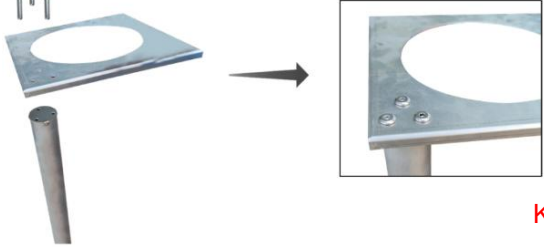

Tip: There is only one bucket with a nut, the upper end uses a Knob Screw and the lower end uses an M5X60 bolt, all other buckets are mounted with an M5X16 bolt.

Etapa 4: Instale todos los cilindros de las varillas, luego fije el pasamanos y las ruedas .

NOTA: Infle las ruedas antes de la instalación.



1 Take out the wheel and cardboard jig.



2 Insert the cardboard jig over the top of the wheel.



3 Insert tire valve into top valve of the hand pump. Bend the plastic handle forward to create a seal so that the tire will inflate more quickly.



4 Inflate until the tire fills the circumference of the cardboard jig.

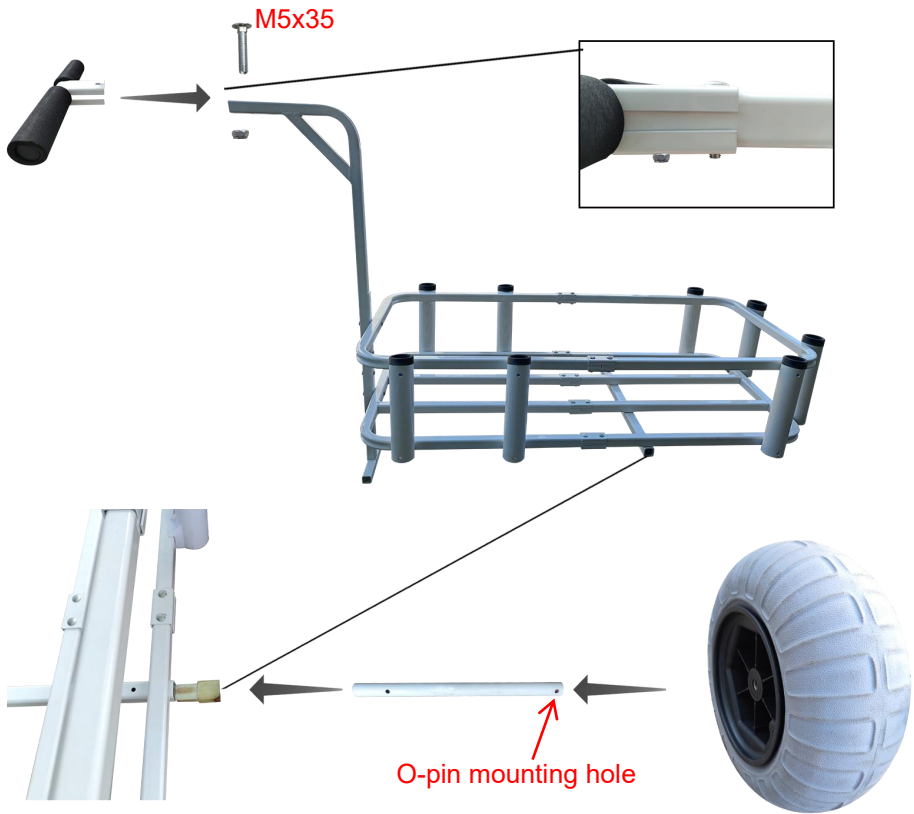

NOTA: Inserte las piezas de plástico del eje de la rueda en los extremos del travesaño inferior del marco, luego inserte el eje de la rueda y finalmente instale la rueda en él.

Paso 5: Coloque primero la lavadora y luego inserte el pasador O.

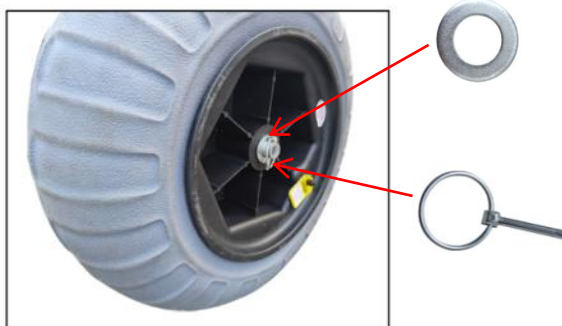

MAINTENANCE

13. Limpiar la superficie después de cada uso.
14. Verifique y confirme que el carrito esté intacto y que la presión de los neumáticos sea normal antes de cada uso.
15. Compruebe que los tornillos estén apretados .

Dirección: Baoshanqu Shuangchenglu 803long 11hao 1602A-1609shi
Shanghai

Importado a AUS: SIHAO PTY LTD, 1 ROKEVA STREETEASTWOOD
NSW 2122 Australia

Importado a EE. UU.: Sanven Technology Ltd, Suite 250, 9166 Anaheim
Place, Rancho Cucamonga, CA 91730



SHUNSHUN GmbH
Römeräcker 9 Z2021, 76351
Linkenheim-Hochstetten, Germany



Pooledas Group Ltd
Unit 5 Albert Edward House, The
Pavilions Preston, United Kingdom

Hecho en china

VEVOR[®]

TOUGH TOOLS, HALF PRICE

Técnico Certificado de soporte y garantía electrónica

www.vevor.com/support

VEVOR[®]

TOUGH TOOLS, HALF PRICE

Wsparcie techniczne i certyfikat e-gwarancji

www.vevor.com/support

WÓZEK WĘDKARSKI

MODEL: YK-400

We continue to be committed to provide you tools with competitive price.

"Save Half", "Half Price" or any other similar expressions used by us only represents an estimate of savings you might benefit from buying certain tools with us compared to the major top brands and does not necessarily mean to cover all categories of tools offered by us. You are kindly reminded to verify carefully when you are placing an order with us if you are actually saving half in comparison with the top major brands.

VEVOR®

TOUGH TOOLS, HALF PRICE

FISHING CART

MODEL: YK-400



NEED HELP? CONTACT US!

Have product questions? Need technical support? Please feel free to contact us:

Technical Support and E-Warranty Certificate
www.vevor.com/support

This is the original instruction, please read all manual instructions carefully before operating. VEVOR reserves a clear interpretation of our user manual. The appearance of the product shall be subject to the product you received. Please forgive us that we won't inform you again if there are any technology or software updates on our product.

SAFETY INSTRUCTIONS

1. Sprawdź i potwierdź, że wózek jest nienaruszony i czy ciśnienie w oponach jest prawidłowe normalne przed każdym użyciem. Przed użyciem kół należy trochę napompować i uważać, aby nie napompować nadmiernie!
2. Zabrania się przewożenia osób w jakimkolwiek stanie.
3. Zabrania się ładowania artykułów na terenie nierównym i pagórkowatym.
4. Przeciążanie jest surowo zabronione.
5. Nie poruszaj się zbyt szybko, mijając dziury.

MODEL AND PARAMETERS

Model	YK-400
Maks. Obciążenie	350 funtów
Koła	18-calowe (po napompowaniu) , nadmuchiwane
Beczka na wędkę	8
Rozmiar ramy (wewnętrzny)	41,5 x 18 x 8 cali
Materiał	Stop aluminium
Kolor	Biały

STRUCTURE DIAGRAM

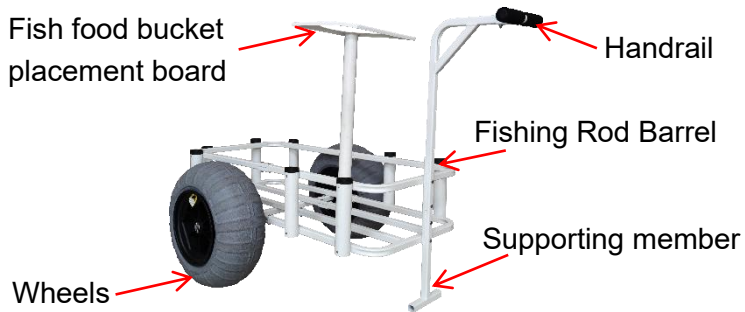

INSTALLATION



Blokada połączenia B x12	koła x2	Podkładka x2

X1e x 2 _	O- pin x2	Rozpórka osi x2

--	--	--

Beczka na wędkę x 7	Beczka na wędkę x 1 (Z nakrętką)	Śruba z gałką x 1
		
Klucz sześciokątny 4 mm x 2	Klucz sześciokątny 3 mm x 1	W rench x 1
		
Śruby M6x50 x3 (Potrzebuję dwóch, jeszcze jednego)	Śruby M5x35 x14 (Potrzebuję trzynastu, jeszcze jednego)	Śruby M5x16 x19 (Potrzebuję osiemnastu, jeszcze jednego)
		
Śruby M5x60 x2 (Potrzebuję jednego, jeszcze jednego)	Śruby M6x25 x3 (Potrzebuję dwóch, jeszcze jednego)	Kartonowy przyrząd do mocowania kół x 1
		
Instrukcja obsługi x1	Pompka ręczna x1	

Krok 1: Połącz ze sobą dwie dolne ramy za pomocą śrub M5x35 i bloku łączącego.

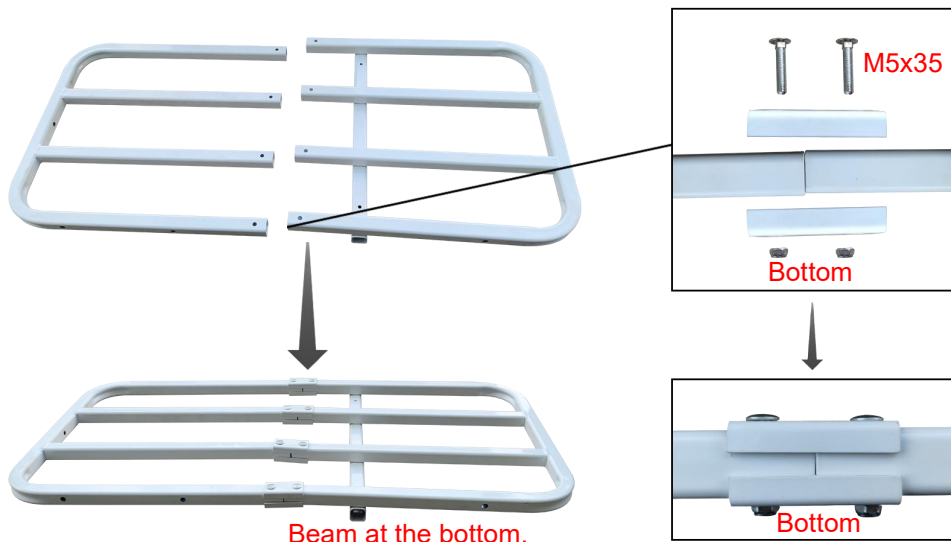

Krok 2: **W ten sam sposób** przymocuj górną ramę.

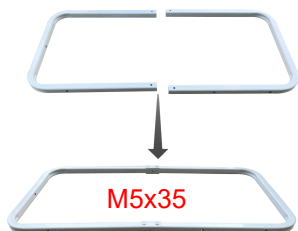

Krok 3: Montaż ramy . _

UWAGA: Ramy posiadają wstępnie nawiercone otwory do montażu beczek wędkarskich. Liczba wstępnie nawierconych otworów w ramie górnej i dolnej po tej samej stronie powinna być taka sama.



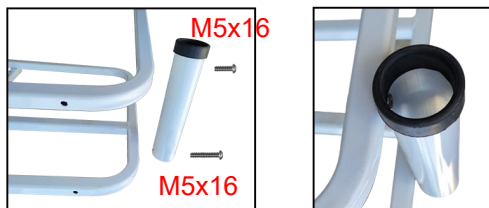
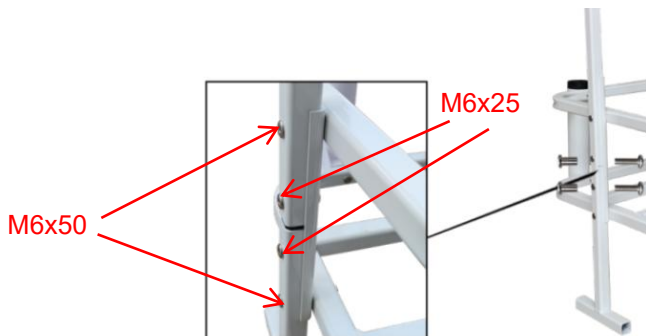
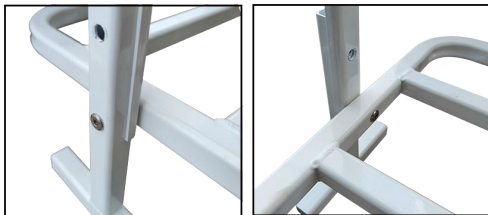

UWAGA: Do dolnej śruby korpusu wędki, w której znajduje się wiadro z karmą dla ryb, wymagany jest śruba M6X60 .

M5x16

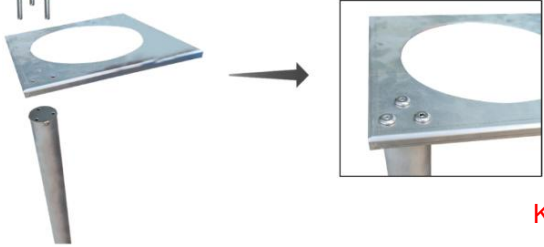

Tip: There is only one bucket with a nut, the upper end uses a Knob Screw and the lower end uses an M5X60 bolt, all other buckets are mounted with an M5X16 bolt.

Krok 4: Zamontuj wszystkie tulejki prętów, następnie przymocuj poręcz i koła .

UWAGA: Przed montażem należy napompować koła.



1 Take out the wheel and cardboard jig.



2 Insert the cardboard jig over the top of the wheel.



3 Insert tire valve into top valve of the hand pump. Bend the plastic handle forward to create a seal so that the tire will inflate more quickly.



4 Inflate until the tire fills the circumference of the cardboard jig.

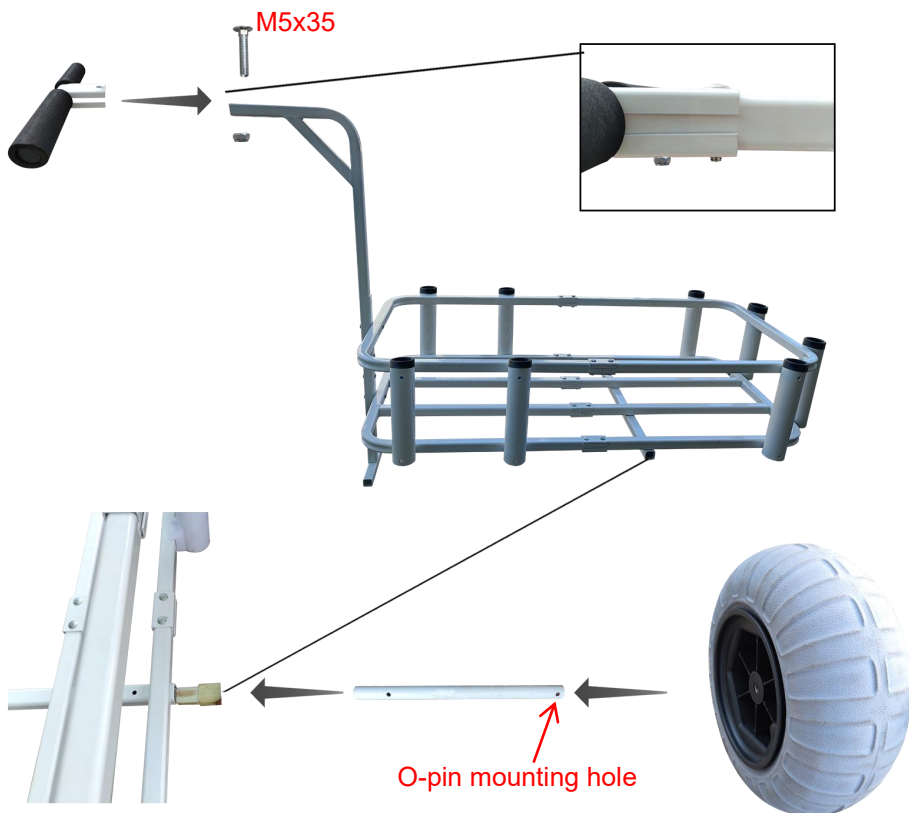

UWAGA: Włóż plastikowe części osi koła w końcówki dolnej poprzeczki ramy, następnie włóż oś koła i na koniec zamontuj na niej koło.

Krok 5: Najpierw włóż podkładkę , a następnie włóż kolek O.

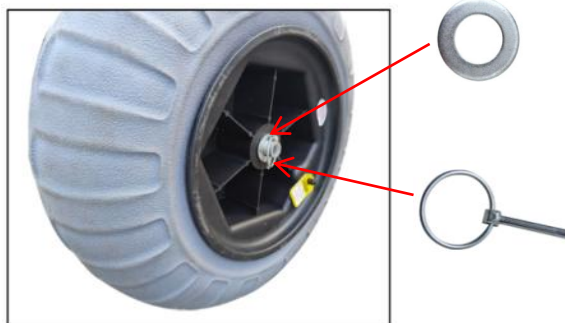

MAINTENANCE

16. Po każdym użyciu należy oczyścić powierzchnię.
17. Sprawdź i potwierdź, że wózek jest nienaruszony i czy ciśnienie w oponach jest prawidłowe normalne przed każdym użyciem.
18. Sprawdź, czy śruby są dokręcone .

Adres: Baoshanqu Shuangchenglu 803long 11hao 1602A-1609shi
Szanghaj

Import do AUS: SIHAO PTY LTD, 1 ROKEVA STREETEASTWOOD NSW
2122 Australia

Import do USA: Sanven Technology Ltd, Suite 250, 9166 Anaheim Place,
Rancho Cucamonga, CA 91730

EC	REP
-----------	------------

SHUNSHUN GmbH
Römeräcker 9 Z2021, 76351
Linkenheim-Hochstetten, Germany

UK	REP
-----------	------------

Pooledas Group Ltd
Unit 5 Albert Edward House, The
Pavilions Preston, United Kingdom

Wyprodukowano w Chinach

VEVOR[®]

TOUGH TOOLS, HALF PRICE

Techniczny Certyfikat wsparcia i e-gwarancji

www.vevor.com/support

VEVOR[®]

TOUGH TOOLS, HALF PRICE

Technische ondersteuning en e-garantiecertificaat

www.vevor.com/support

VISSERSKAR

MODEL: YK-400

We continue to be committed to provide you tools with competitive price.

"Save Half", "Half Price" or any other similar expressions used by us only represents an estimate of savings you might benefit from buying certain tools with us compared to the major top brands and does not necessarily mean to cover all categories of tools offered by us. You are kindly reminded to verify carefully when you are placing an order with us if you are actually saving half in comparison with the top major brands.

VEVOR[®]

TOUGH TOOLS, HALF PRICE

FISHING CART

MODEL: YK-400



NEED HELP? CONTACT US!

Have product questions? Need technical support? Please feel free to contact us:

Technical Support and E-Warranty Certificate
www.vevor.com/support

This is the original instruction, please read all manual instructions carefully before operating. VEVOR reserves a clear interpretation of our user manual. The appearance of the product shall be subject to the product you received. Please forgive us that we won't inform you again if there are any technology or software updates on our product.

SAFETY INSTRUCTIONS

1. Controleer en bevestig dat de wagen intact is en dat de bandenspanning hoog is normaal vóór elk gebruik. Blaas een beetje op voordat u de wielen gebruikt, en pas op dat u de wielen niet te hard opblaast!
2. Het is onder alle omstandigheden verboden mensen te vervoeren.
3. Het is verboden artikelen te laden op oneffen en heuvelachtig terrein.
4. Overbelasting is ten strengste verboden.
5. Beweeg niet te snel bij het passeren van kuilen.

MODEL AND PARAMETERS

Model	YK-400
Max. Laden	350 pond
Wielen	18 inch (na opgeblazen maat) , opblaasbaar,
Hengel vat	8
Framemaat (binnenkant)	41,5 x 18 x 8 inch
Materiaal	Aluminium legering
Kleur	Wit

STRUCTURE DIAGRAM

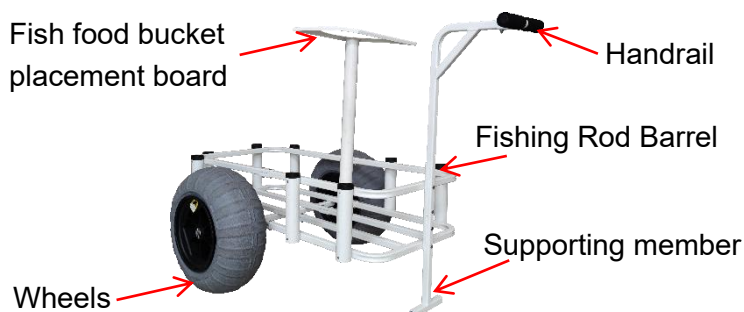

INSTALLATION

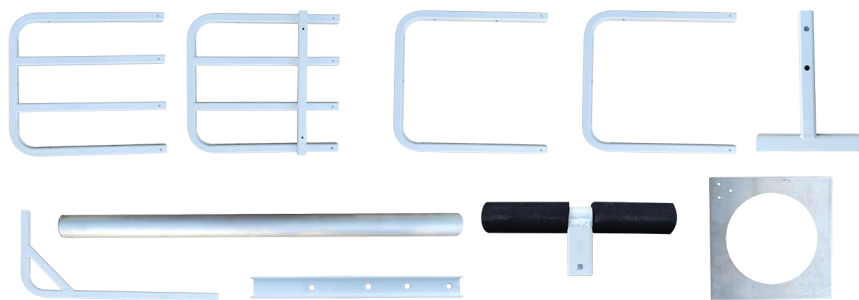

Framedeel x1 (elk voor één)



Verbindingsblokslot x12



wielen x2



Wasmachine x2



Een xl x 2



O- pin x2



As afstandhouder x2



Hengeltou x 7



Hengelvat x 1
(Met moer)



Knopschroef x 1



4 mm inbussleutel x 2



3 mm inbussleutel x 1



W rench x 1

		
M6x50 Bouten x3 (Ik heb er twee nodig, nog één)	M5x35 Bouten x14 (Dertien nodig, nog één)	M5x16 Bouten x19 (Ik heb achttien nodig, nog één)

		
M5x60 Bouten x2 (Ik heb er nog één nodig)	M6x25 Bouten x3 (Ik heb er twee nodig, nog één)	Wielmal karton x 1

		
Gebruikershandleiding x1	Handpomp x1	

Stap 1: Verbind de twee onderste frames met elkaar met behulp van de M5x35 bouten en het verbindingsblok.

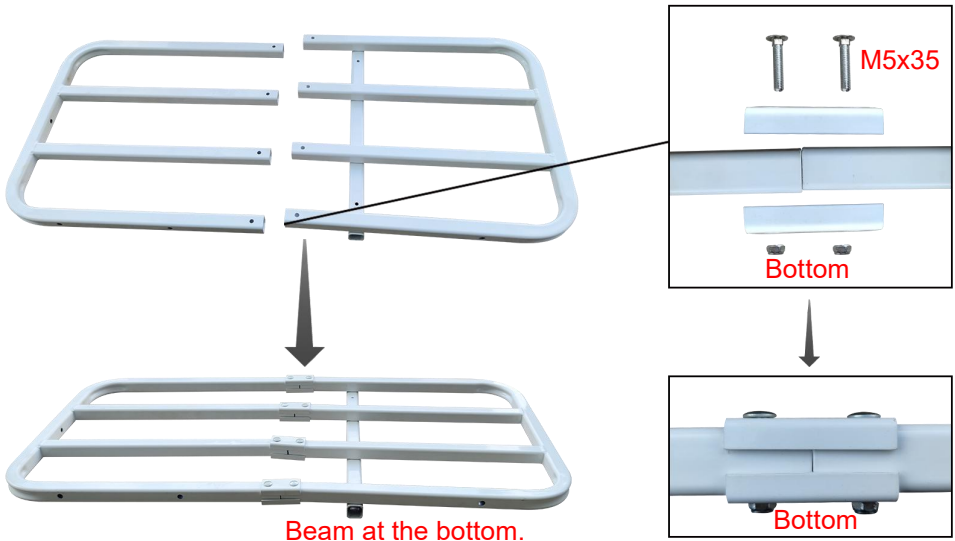

Stap 2: Bevestig het bovenframe op dezelfde manier.

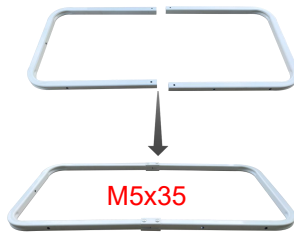

Stap 3: Monteren van het kozijn .

OPMERKING: De frames zijn voorzien van voorgeboorde gaten voor het monteren van de vistonnen. Het aantal voorgeboorde gaten op het bovenste en onderste frame aan dezelfde kant moet hetzelfde zijn.



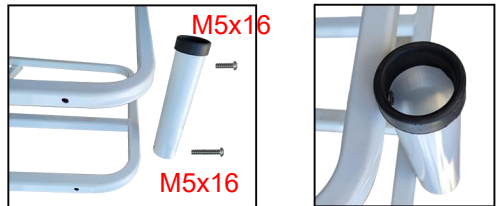
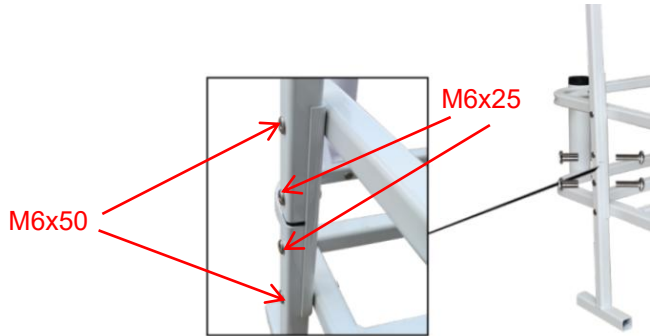
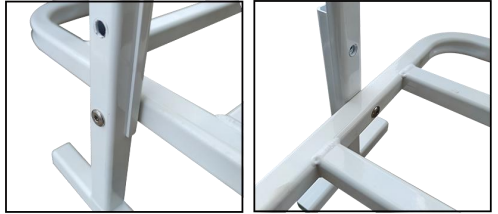

OPMERKING: M6X60 is vereist voor de onderste bout van de hengelloop waar de visvoeremmer wordt geplaatst .

M5x16

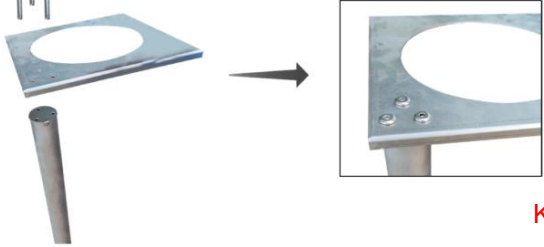

Tip: There is only one bucket with a nut, the upper end uses a Knob Screw and the lower end uses an M5X60 bolt, all other buckets are mounted with an M5X16 bolt.

Stap 4: Installeer alle stangtonnen en bevestig vervolgens de leuning en de wielen .

OPMERKING: Pomp de wielen op voordat u ze installeert.



1 Take out the wheel and cardboard jig.



2 Insert the cardboard jig over the top of the wheel.



3 Insert tire valve into top valve of the hand pump. Bend the plastic handle forward to create a seal so that the tire will inflate more quickly.



4 Inflate until the tire fills the circumference of the cardboard jig.

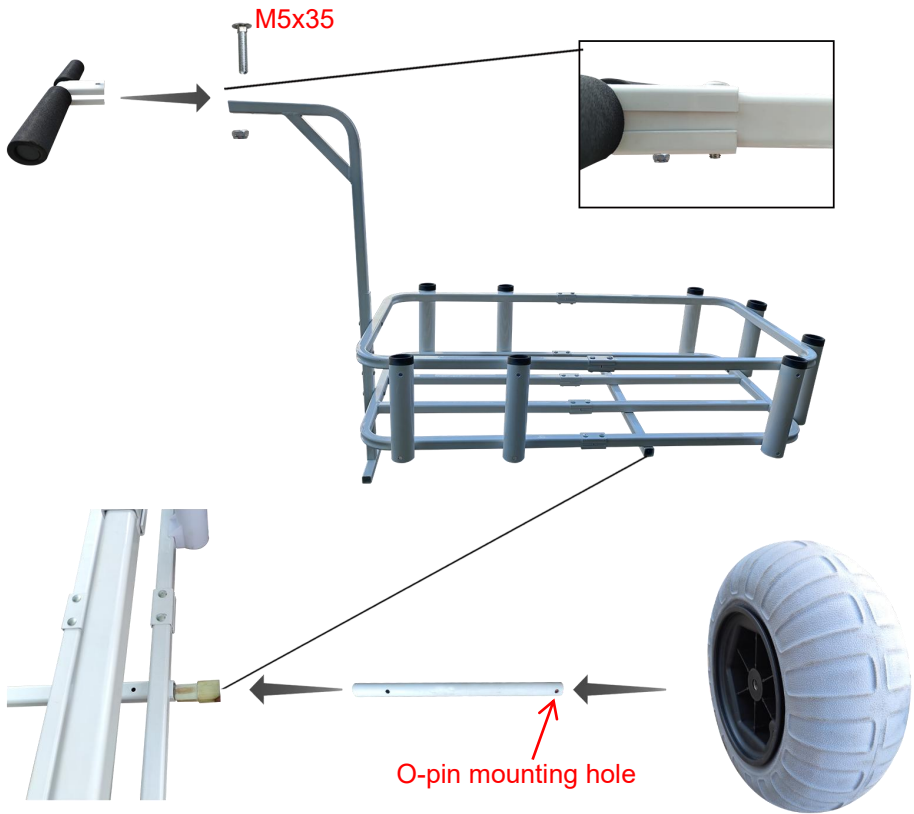

OPMERKING: Steek de plastic delen van de wielas in de uiteinden van de onderste dwarsbalk van het frame, steek vervolgens de wielas erin en monteer tenslotte het wiel erop.

Stap 5: Plaats eerst de sluitring en plaats vervolgens de O- pin.

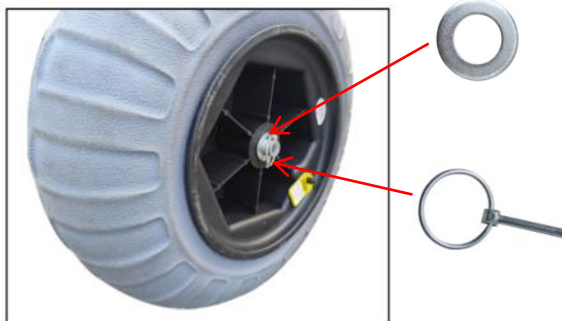

MAINTENANCE

19. Reinig het oppervlak na elk gebruik.
20. Controleer en bevestig dat de wagen intact is en dat de bandenspanning hoog is normaal vóór elk gebruik.
21. Controleer of de bouten goed vastzitten .

Adres: Baoshanqu Shuangchenglu 803long 11hao 1602A-1609shi
Shanghai

Geïmporteerd naar AUS: SIHAO PTY LTD, 1 ROKEVA
STREETEASTWOOD NSW 2122 Australië

Geïmporteerd naar de VS: Sanven Technology Ltd, Suite 250, 9166
Anaheim Place, Rancho Cucamonga, CA 91730



SHUNSHUN GmbH
Römeräcker 9 Z2021, 76351
Linkenheim-Hochstetten, Germany



Pooledas Group Ltd
Unit 5 Albert Edward House, The
Pavilions Preston, United Kingdom

Gemaakt in China

VEVOR[®]

TOUGH TOOLS, HALF PRICE

Technisch Ondersteuning en e-garantiecertificaat

www.vevor.com/support

VEVOR[®]

TOUGH TOOLS, HALF PRICE

Teknisk support och e-garanticertifikat

www.vevor.com/support

FISKEVAGN

MODELL: YK-400

We continue to be committed to provide you tools with competitive price.

"Save Half", "Half Price" or any other similar expressions used by us only represents an estimate of savings you might benefit from buying certain tools with us compared to the major top brands and does not necessarily mean to cover all categories of tools offered by us. You are kindly reminded to verify carefully when you are placing an order with us if you are actually saving half in comparison with the top major brands.

VEVOR[®]

TOUGH TOOLS, HALF PRICE

FISHING CART

MODELL: YK-400



NEED HELP? CONTACT US!

Have product questions? Need technical support? Please feel free to contact us:

Technical Support and E-Warranty Certificate
www.vevor.com/support

This is the original instruction, please read all manual instructions carefully before operating. VEVOR reserves a clear interpretation of our user manual. The appearance of the product shall be subject to the product you received. Please forgive us that we won't inform you again if there are any technology or software updates on our product.

SAFETY INSTRUCTIONS

1. Kontrollera och bekräfta att vagnen är hel och att däcktrycket är normalt före varje användning. Blås upp lite innan du använder hjulen och var försiktig så att du inte blåser upp för mycket!
2. Det är förbjudet att bära människor under alla omständigheter.
3. Det är förbjudet att lasta föremål i ojämn och kuperad terräng.
4. Överbelastning är strängt förbjuden.
5. Rör dig inte för snabbt när du passerar gropar.

MODEL AND PARAMETERS

Modell	YK-400
Max. Ladda	350 pund
Hjul	18 tum (efter uppblåst storlek) , uppblåsbara,
Fiskspö fat	8
Ramstorlek (inuti)	41,5 x 18 x 8 tum
Material	Aluminiumlegering
Färg	Vit

STRUCTURE DIAGRAM

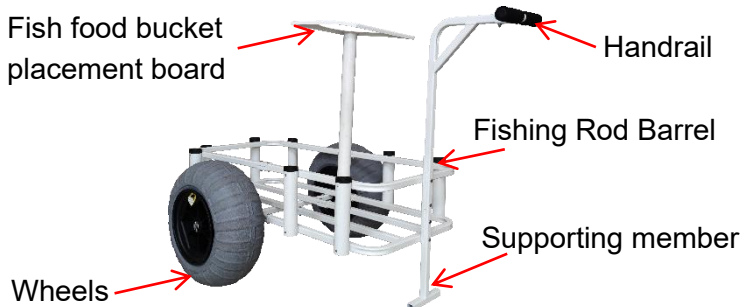

INSTALLATION

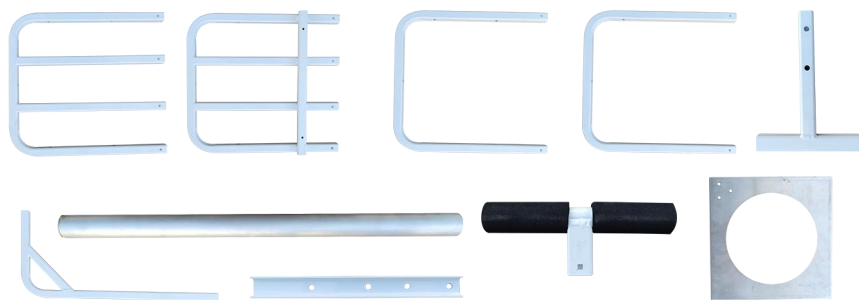

Ramdel x1 (Var och en för en)



Anslutning B lås x12



hjul x2



Bricka x2



A xle x 2



O- stift x2



Axeldistans x2



Fiskspö fat x 7



Fiskspö fat x 1
(Med mutter)



Knoppskruv x 1



4 mm sexkantsnyckel x 2





3 mm insexnyckel x 1



W rench x 1

		
M6x50 Bultar x3 (Behöver två, en till)	M5x35 Bultar x14 (Behöver tretton, en till)	M5x16 Bultar x19 (Behöver arton, en till)

		
M5x60 Bultar x2 (Behöver en, en till)	M6x25 Bultar x3 (Behöver två, en till)	Hjuljigg kartong x 1

		
Användarmanual x1	Handpump x1	

Steg 1: Koppla ihop de två nedre ramarna med M5x35-bultarna och anslutningsblocket.

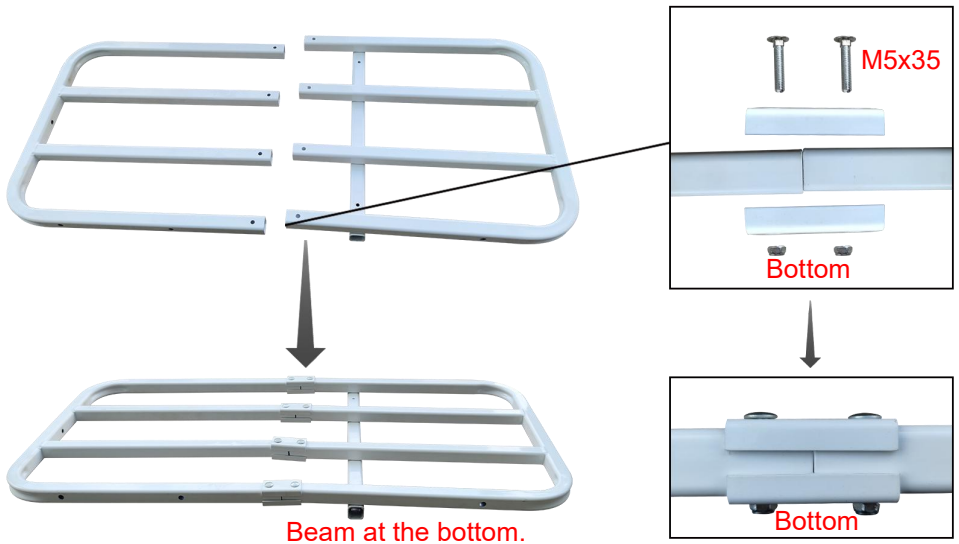

Steg 2: Fäst den övre ramen på samma sätt.

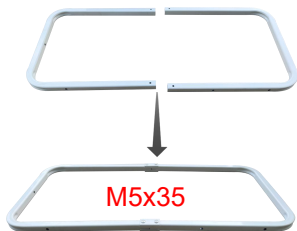

Steg 3: Montering av ramen .

OBS: Ramarna har förborrade hål för montering av fisketunnorna. Antalet förborrade hål på den övre och nedre ramen på samma sida ska vara detsamma.



Pay attention to the location of the fishing rod barrel.

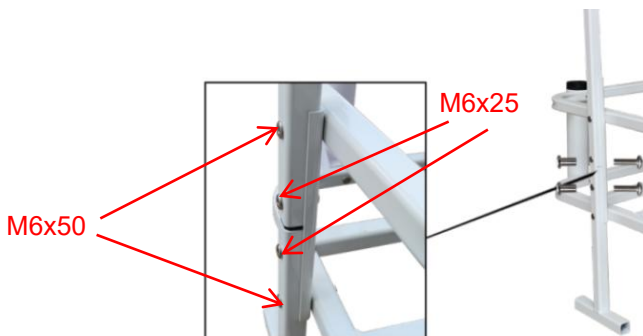
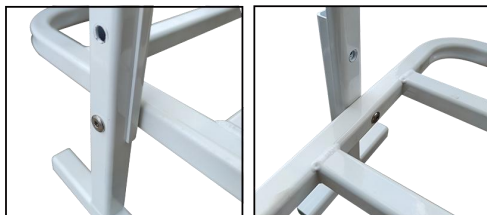

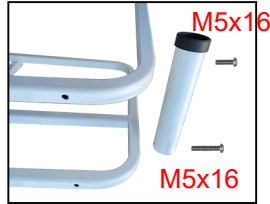

OBS: M6X60 krävs för bottenbulten på fiskespöpipan där fiskmatshinken placeras .

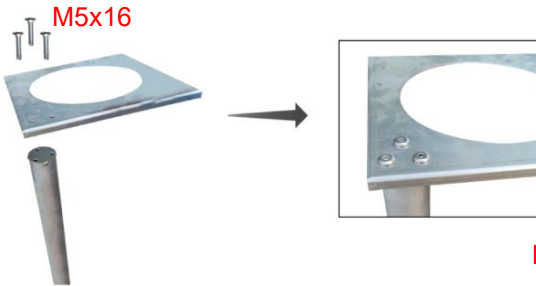

Tip: There is only one bucket with a nut, the upper end uses a Knob Screw and the lower end uses an M5X60 bolt, all other buckets are mounted with an M5X16 bolt.

Steg 4: Installera alla stångcylindrar och fixera sedan ledstången och hjulen .

OBS: Blås upp hjulen före installation.



1 Take out the wheel and cardboard jig.



2 Insert the cardboard jig over the top of the wheel.



3 Insert tire valve into top valve of the hand pump. Bend the plastic handle forward to create a seal so that the tire will inflate more quickly.



4 Inflate until the tire fills the circumference of the cardboard jig.

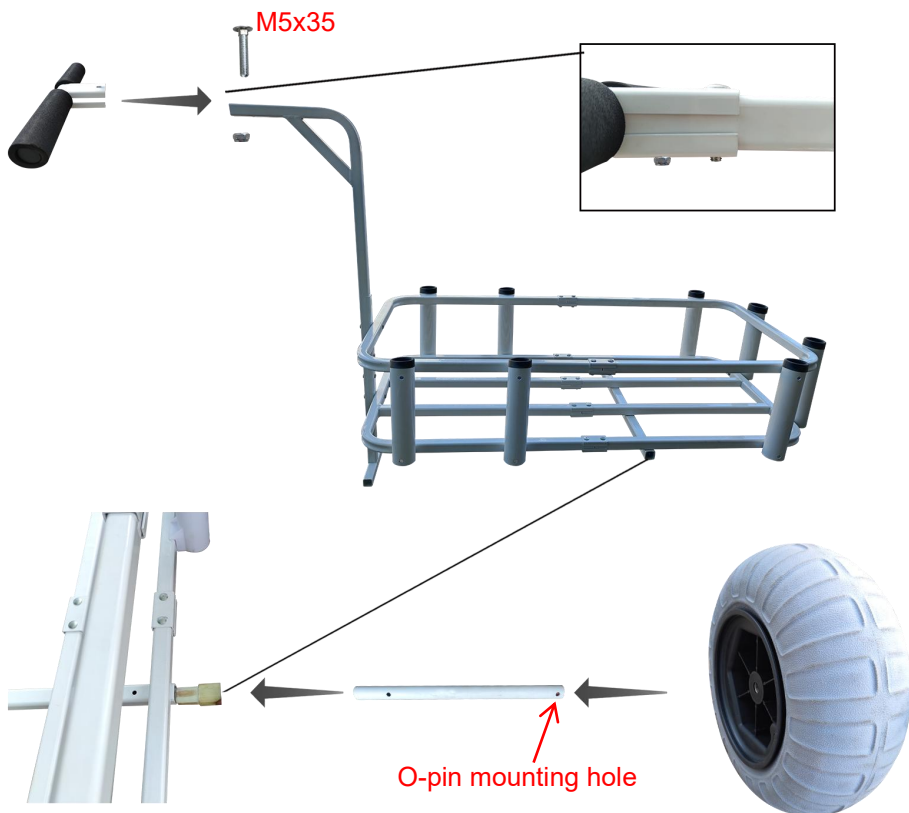

OBS: Sätt in plastdelarna på hjulaxeln i ändarna av den nedre tvärbalken på ramen, sätt sedan in hjulaxeln och installera slutligen hjulet på den.

Steg 5: Sätt först i brickan och sätt sedan in O- stiftet.

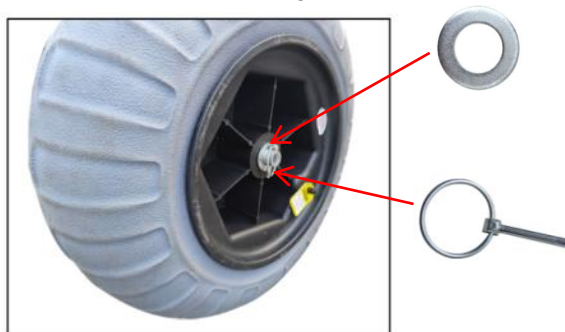

MAINTENANCE

22. Rengör ytan efter varje användning.
23. Kontrollera och bekräfta att vagnen är hel och att däcktrycket är normalt före varje användning.
24. Kontrollera att bultarna är åtdragna .

Adress: Baoshanqu Shuangchenglu 803long 11hao 1602A-1609shi
Shanghai

Importerad till AUS: SIHAO PTY LTD, 1 ROKEVA STREETEASTWOOD
NSW 2122 Australien

Importerad till USA: Sanven Technology Ltd, Suite 250, 9166 Anaheim
Place, Rancho Cucamonga, CA 91730

EC	REP	SHUNSHUN GmbH Römeräcker 9 Z2021, 76351 Linkenheim-Hochstetten, Germany
-----------	------------	---

UK	REP	Pooledas Group Ltd Unit 5 Albert Edward House, The Pavilions Preston, United Kingdom
-----------	------------	--

Tillverkad i Kina

VEVOR[®]

TOUGH TOOLS, HALF PRICE

Teknisk Support och e-garanticertifikat

www.vevor.com/support