

# VEVOR

**Upgrade · The Home Creator Way**

Dog Treadmill

MODEL: SSKL-3 SSKM-3

**MODEL: SSKL-3 SSKM-3**

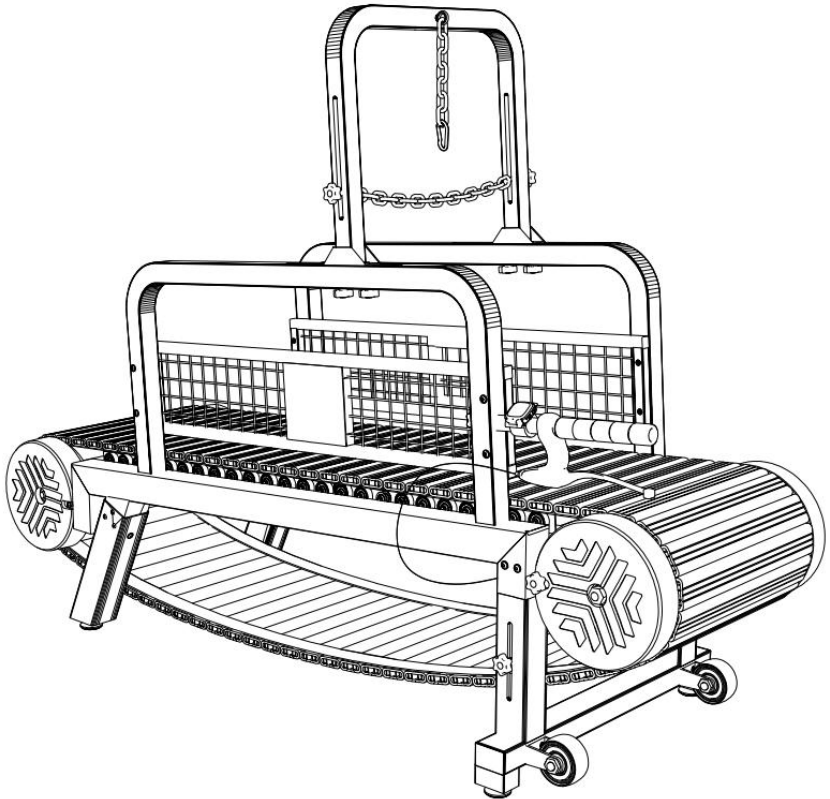

This is the original instruction, please read all manual instructions carefully before operating. VEVOR reserves a clear interpretation of our user manual. The appearance of the product shall be subject to the product you received. Please forgive us that we won't inform you again if there are any technology or software updates on our product.

# Dog Treadmill Manual Instruction

## Important Safety Information:

- Read all instructions before using the treadmill.
- Do not use the treadmill if your dog has any health problems or injuries that may be exacerbated by exercise.
- Always supervise your dog when using the treadmill.
- Keep children and other pets away from the treadmill when in use.
- Connect your dog to the treadmill by the harness rather than a collar.
- Use the treadmill in short intervals (no more than 20 minutes at a time, with 10 minutes of running and 10 minutes of walking separated) to prevent your dog from becoming overheated or exhausted. Reduce the time if your dog is not in great condition or feel uncomfortable.

## Using the Treadmill:

1. Allow your dog to explore the machine and make your dog acclimate to it. Simply having them feel comfortable standing or sitting on it.
2. Attach your dog to the treadmill with the harness on. Never rely on them to figure out what to do just yet be patience. Position yourself in front of them and call them directly. Encourage them to move their paws slowly. Don't be concerned if they don't. Wait, give them praise.
3. Repeat Step#2 until they can walk on it by themselves. Always keep them walk around instead of running at first. This can help them get used to the machine entirely. After getting familiar with the machine, encourage them to run by standing in front of them and applauding or calling them to you.
4. When finished using the treadmill clean up the treadmill.

## Maintenance:

- Keep the treadmill clean and free of debris.
- Regularly inspect the machine for signs of wear and tear or damage
- Lubricate the treadmill as directed by the manufacturer.
- Store the treadmill in a dry and safe location when not in use.

## **FCC INFORMATION**

**CAUTION:** Changes or modifications not expressly approved by the party responsible for compliance could void the user's authority to operate the equipment!

This device complies with Part 15 of the FCC Rules. Operation is subject to the following two conditions:

- 1) This product may cause harmful interference.
- 2) This product must accept any interference received, including interference that may cause undesired operation.

**WARNING:** Changes or modifications to this product not expressly approved by the party responsible for compliance could void the user's authority to operate the product.

**Note:** This product has been tested and found to comply with the limits for a Class B digital device pursuant to Part 15 of the FCC Rules. These limits are designed to provide reasonable protection against harmful interference in a residential installation.

This product generates, uses and can radiate radio frequency energy, and if not installed and used in accordance with the instructions, may cause harmful interference to radio communications. However, there is no guarantee that interference will not occur in a particular installation. If this product does cause harmful interference to radio or television reception, which can be determined by turning the product off and on, the user is encouraged to try to correct the interference by one or more of the following measures.

- Reorient or relocate the receiving antenna.
- Increase the distance between the product and receiver.
- Connect the product to an outlet on a circuit different from that to which the receiver is connected.
- Consult the dealer or an experienced radio/TV technician for assistance.



# WARNING!

**INGESTION HAZARD:** This product contains a button cell or coin battery.  
**DEATH** or serious injury can occur if ingested.  
 A swallowed button cell or coin battery can cause internal **Chemical Burns**  
 in as little as **2 hours**.  
 KEEP new and used batteries **OUT OF REACH of CHILDREN**.  
**Seek immediate medical attention** if a battery is suspected to be  
 swallowed or inserted inside any part of the body.



# WARNING!

**INGESTION HAZARD:** This product contains a button cell or coin battery.  
**DEATH** or serious injury can occur if ingested.  
 A swallowed button cell or coin battery can cause internal **Chemical Burns**  
 in as little as **2 hours**.  
 KEEP new and used batteries **OUT OF REACH of CHILDREN**.  
**Seek immediate medical attention** if a battery is suspected to be  
 swallowed or inserted inside any part of the body.











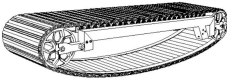

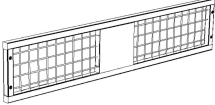
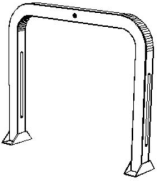
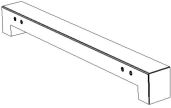
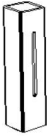

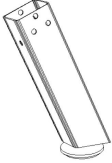

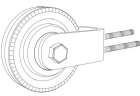

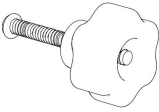
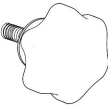
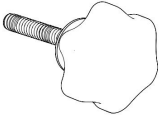
## SPECIFICATIONS

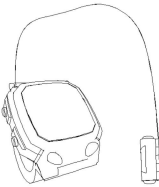
Model	SSKL-3
Product Size	1910*570*1400mm
Color	Black

Model	SSKM-3
Product Size	1750*510*1360mm
Color	Black

# PARTS LIST



 <p>A x1</p>	 <p>B x2</p>	 <p>C x2</p>	 <p>D x1</p>
 <p>E x1</p>	 <p>F x2</p>	 <p>G x2</p>	 <p>H x2</p>
 <p>M8*80mm J x4</p>	 <p>K x2</p>	 <p>L x1</p>	 <p>M x1</p>
 <p>N x4</p>	 <p>P x2</p>	 <p>Q x3</p>	 <p>T x4</p>
 <p>U x1</p>	 <p>M8*60mm S x20</p>	 <p>M8*25mm V x16</p>	 <p>W x2</p>
		 <p>R x50</p>	 <p>Y x1</p>

# ASSEMBLY STEPS



<b>STEP1</b>										
	E	X1	F	X2	G	X2	P	X2	R	X2

	The height of the treadmill can be adjusted by part P										
S	X2										

<b>STEP2</b>										
	A	X1	H	X2	R	X12	V	X12		

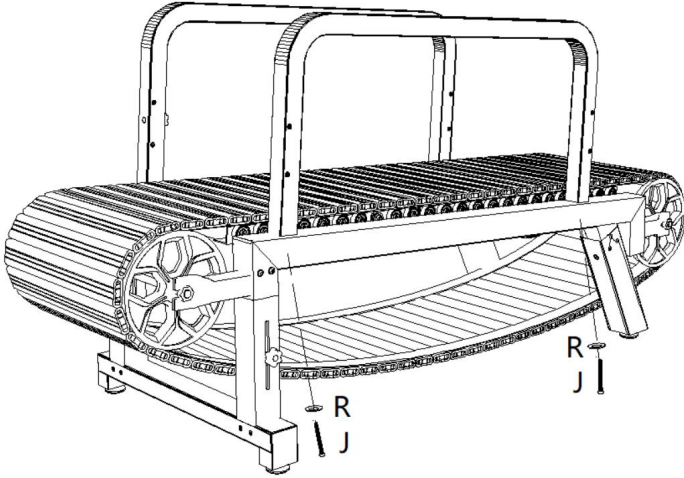
<b>STEP3</b>						
	B	X2	R	X4	J	X4

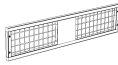

<b>STEP4</b>						
	C	X2	R	X8	S	X8

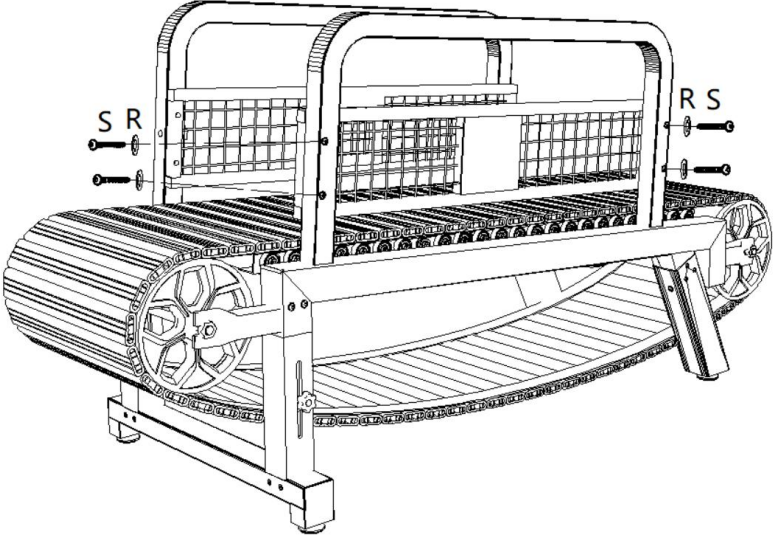

<b>STEP5</b>										
	D	X1	L	X1	M	X1	N	X4	R	X14

Component M can be fixed on the top (position) or on Component L.

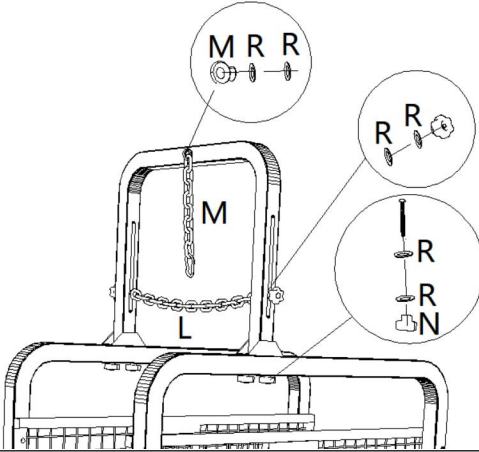

<b>STEP6</b>		
	K	X2

Remove the nut from component K, pass it through bracket E, and then tighten the nut.

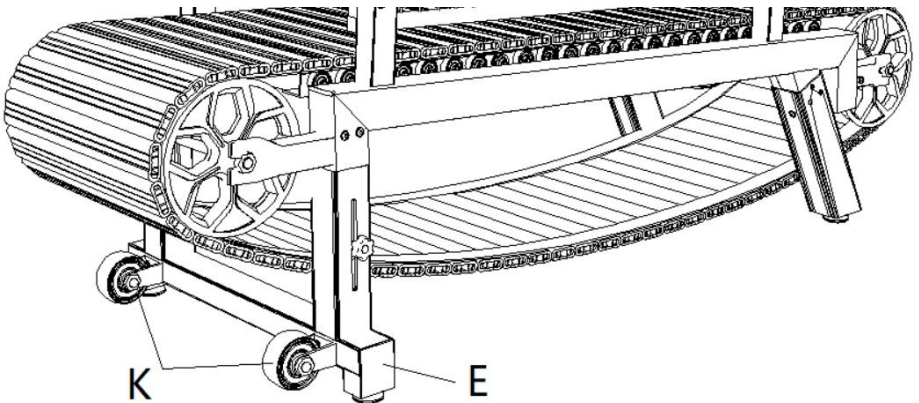

**STEP7**

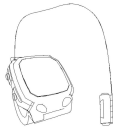

T

X1

U

X1

Install the sensor flush with the position shown in the diagram. Route the outgoing wire through the slot, and during installation, ensure the wire does not come into contact with the rotating wheel.

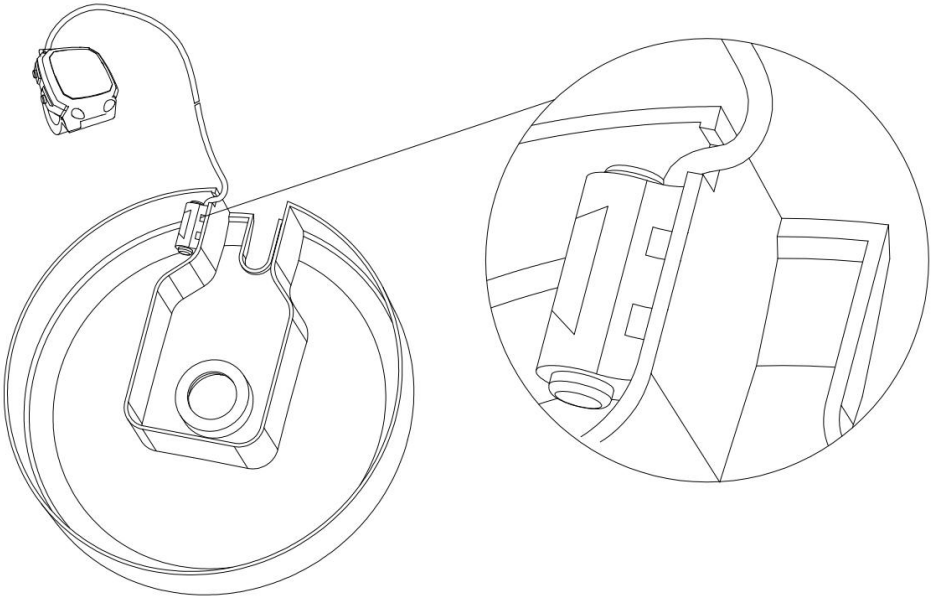

<b>STEP8</b>									
	T	X4	V	X4	R	X4	Q	X2	

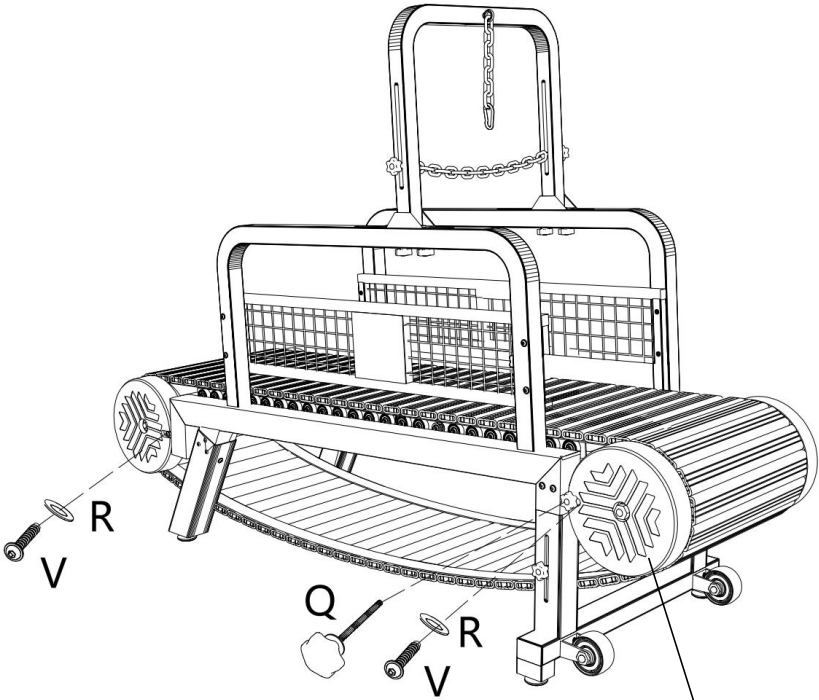

Install component T (equipped with a sensor) from the previous Step 7 at this position.

The running resistance of the treadmill can be adjusted by the tightness adjustment of part Q.

**STEP9**

Q

X1

R

X1

U

X1

Install the brake and secure the odometer.

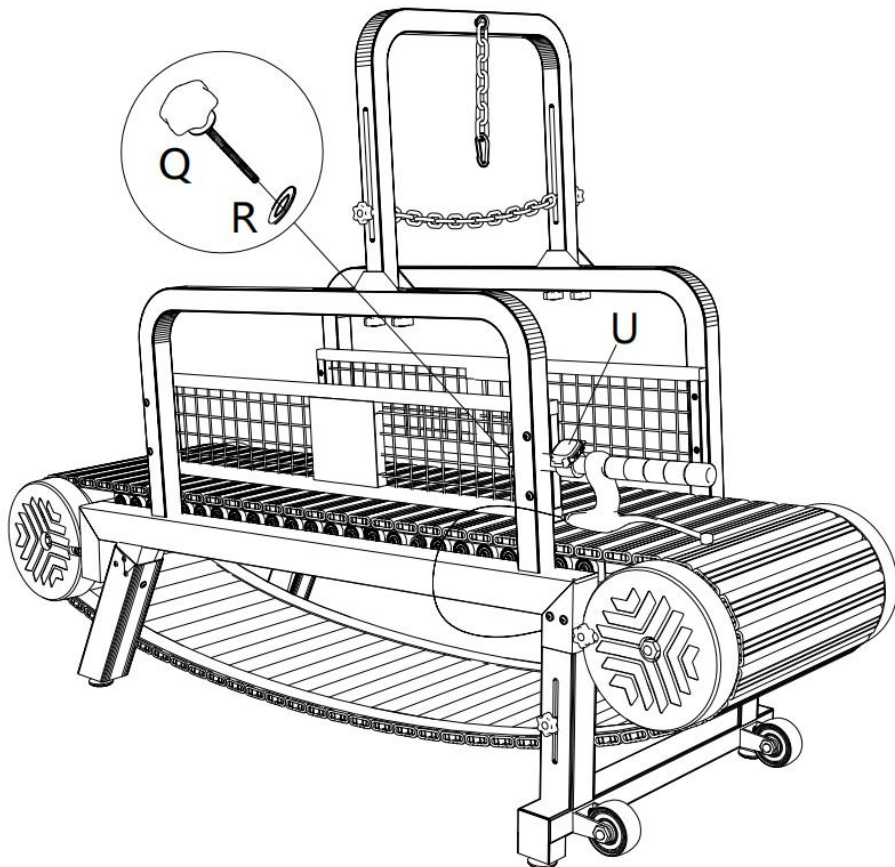

**Manufacturer:**Shanghaimuxinmuyeyouxiangongsi

**Address:** Shuangchenglu 803nong11hao1602A700x450x12451609shi,  
baoshanqu, shanghai 200000 CN.

**Imported to AUS:** SIHAO PTY LTD. 1 ROKEVA STREETEASTWOOD  
NSW 2122 Australia

**Imported to USA:** Sanven Technology Ltd. Suite 250, 9166 Anaheim  
Place, Rancho Cucamonga, CA 91730

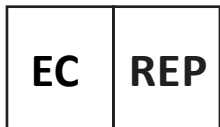

E-CrossStu GmbH

Mainzer Landstr.69, 60329 Frankfurt am Main.



YH CONSULTING LIMITED.

C/O YH Consulting Limited Office 147, Centurion House,  
London Road, Staines-upon-Thames, Surrey, TW18 4AX





# VEVOR

**Upgrade · The Home Creator Way**

Hundelaufband

MODELL: SSKL-3 SSKM-3

**MODELL: SSKL-3 SSKM-3**

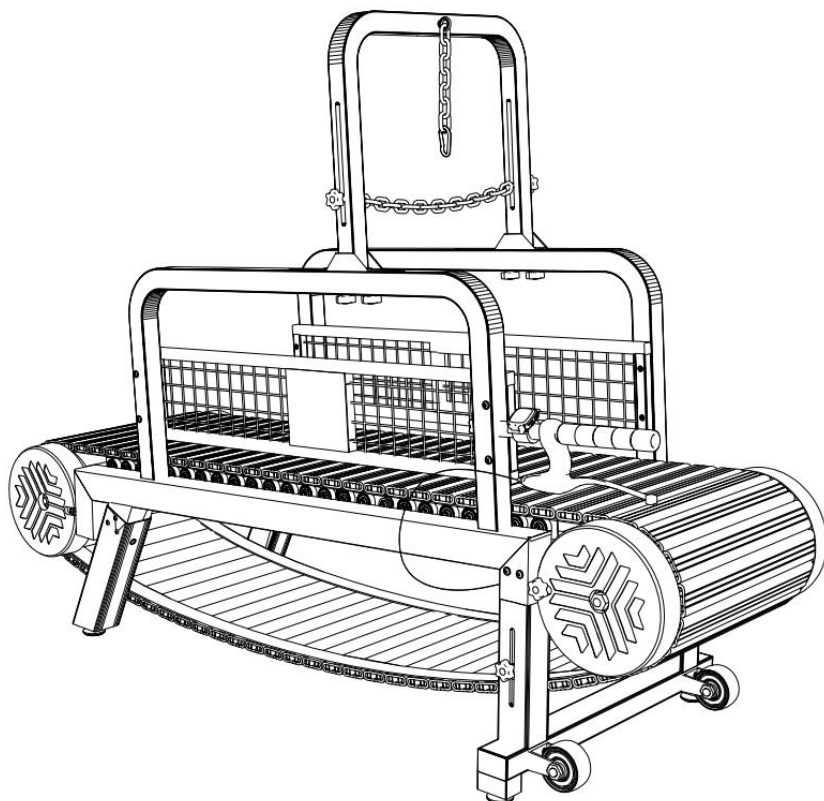

Dies ist die Originalanleitung. Bitte lesen Sie die gesamte Bedienungsanleitung vor der Inbetriebnahme sorgfältig durch. VEVOR behält sich die Auslegung der Bedienungsanleitung vor. Das Aussehen des Produkts kann von dem gelieferten Produkt abweichen. Wir bitten um Verständnis, dass wir Sie nicht erneut über etwaige Technologie- oder Software-Updates informieren werden.

# Bedienungsanleitung für das Hundelaufband

## Wichtige Sicherheitshinweise:

- Alles lesen Bitte lesen Sie die Anweisungen vor der Benutzung des Laufbands.
- Nicht verwenden das Laufband krank wenn Ihr Hund hat irgendwelche gesundheitlichen Probleme oder Verletzungen Dies kann durch körperliche Anstrengung noch verstärkt werden.
- Beaufsichtigen Sie Ihren Hund immer, wenn Sie das Laufband benutzen .
- Halten Sie Kinder und andere Haustiere vom Laufband fern , wenn es in Betrieb ist. verwenden .
- Verbinden Sie Ihr Hund zum Laufband durch das Geschirr anstatt durch ein Halsband .
- Verwenden Die Tretmühle Zusammenfassend Intervalle (maximal 20 Minuten am Stück, aufgeteilt in 10 Minuten Laufen und 10 Minuten Gehen), um zu verhindern, dass Ihr Hund überhitzt oder erschöpft wird. Verkürzen Sie die Laufzeit, wenn Ihr Hund zu müde ist. Der Hund ist nicht in bester Verfassung oder fühlt sich unwohl .

## Nutzung des Laufbands:

5. Erlauben Sie Ihrem Hund Erkunden Sie die Maschine und gewöhnen Sie Ihren Hund daran . Sorgen Sie einfach dafür, dass er sich wohlfühlt , wenn er darauf steht oder sitzt. Es.
6. Befestigen Sie Ihren Hund mit dem Geschirr am Laufband. Verlassen Sie sich niemals darauf, dass sie herausfinden, was Noch ist Geduld gefragt. Positioniere dich vor ihnen und rufe. sie direkt. Ermutigen Sie sie, ihre Pfoten langsam zu bewegen. Machen Sie sich keine Sorgen, wenn sie es nicht tun. Warten Sie ab und loben Sie sie .
7. Wiederholen Sie Schritt 2. bis sie darauf laufen können von selbst. Sorgen Sie immer dafür, dass sie herumlaufen. anstatt Anfangs sollten sie laufen . Das kann ihnen helfen , sich vollständig an die Maschine zu gewöhnen. Nachdem ich mich mit der Maschine vertraut gemacht hatte , Ermutigen Sie sie zum Laufen, indem Sie sich vor sie stellen und applaudieren oder sie zu sich rufen .
8. Nach dem Training auf dem Laufband Das Laufband reinigen.

## Wartung :

- Halten das Laufband sauber und frei von Trümmer.
- Regelmäßig Überprüfen Sie die Maschine auf Anzeichen von Verschleiß oder Schaden
- Schmieren Sie das Laufband gemäß den Anweisungen des Herstellers.
- Verstauen Sie das Laufband In A trockener und sicherer Ort, wenn nicht in Gebrauch.

## **FCC - INFORMATIONEN**

**VORSICHT:** Änderungen oder Modifikationen, die nicht ausdrücklich von der für die Einhaltung der Vorschriften verantwortlichen Partei genehmigt wurden, können zum Erlöschen der Berechtigung des Benutzers zum Betrieb des Geräts führen!

Dieses Gerät entspricht Teil 15 der FCC-Bestimmungen. Der Betrieb unterliegt den folgenden zwei Bedingungen:

- 1) Dieses Produkt kann schädliche Störungen verursachen.
- 2) Dieses Produkt muss alle empfangenen Störungen akzeptieren, einschließlich solcher, die einen unerwünschten Betrieb verursachen können.

**WARNUNG:** Änderungen oder Modifikationen an diesem Produkt, die nicht ausdrücklich von der für die Einhaltung der Bestimmungen verantwortlichen Partei genehmigt wurden, können zum Verlust der Berechtigung des Benutzers zum Betrieb des Produkts führen.



**Notiz:** Dieses Produkt wurde geprüft und entspricht den Grenzwerten für digitale Geräte der Klasse B gemäß Teil 15 der FCC-Bestimmungen. Diese Grenzwerte sollen einen angemessenen Schutz vor schädlichen Störungen in Wohngebieten gewährleisten.



Dieses Produkt erzeugt, verwendet und kann Hochfrequenzenergie abstrahlen. Bei nicht vorschriftsmäßiger Installation und Verwendung kann es Störungen des Funkverkehrs verursachen. Es kann jedoch nicht ausgeschlossen werden, dass in bestimmten Fällen Störungen auftreten. Sollte dieses Produkt Störungen beim Radio- oder Fernsehempfang verursachen (was durch Ein- und Ausschalten des Produkts festgestellt werden kann), wird dem Benutzer empfohlen, die Störung durch eine oder mehrere der folgenden Maßnahmen zu beheben.

- Die Empfangsantenne neu ausrichten oder an einem anderen Ort aufstellen.
- Vergrößern Sie den Abstand zwischen Produkt und Empfänger.
- Schließen Sie das Produkt an eine Steckdose an, die zu einem

anderen Stromkreis gehört als der, an dem der Empfänger angeschlossen ist.

- Wenden Sie sich an Ihren Händler oder einen erfahrenen Radio-/Fernsehtechniker, um Unterstützung zu erhalten.

 <b>WARNING!</b>	
<p><b>INGESTION HAZARD:</b> This product contains a button cell or coin battery. <b>DEATH</b> or serious injury can occur if ingested. A swallowed button cell or coin battery can cause internal <b>Chemical Burns</b> in as little as <b>2 hours</b>. KEEP new and used batteries <b>OUT OF REACH of CHILDREN</b>. <b>Seek immediate medical attention</b> if a battery is suspected to be swallowed or inserted inside any part of the body.</p>	











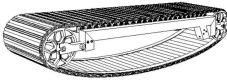

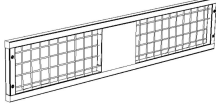
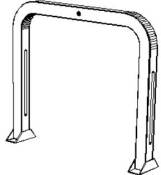
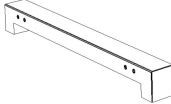
 <b>WARNING!</b>	
<p><b>INGESTION HAZARD:</b> This product contains a button cell or coin battery. <b>DEATH</b> or serious injury can occur if ingested. A swallowed button cell or coin battery can cause internal <b>Chemical Burns</b> in as little as <b>2 hours</b>. KEEP new and used batteries <b>OUT OF REACH of CHILDREN</b>. <b>Seek immediate medical attention</b> if a battery is suspected to be swallowed or inserted inside any part of the body.</p>	

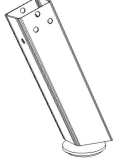

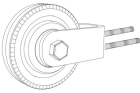

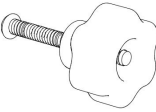

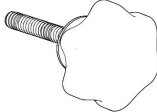
## SPEZIFIKATIONEN

Modell	SSKL- 3
Produktgröße	1910*570*1400mm
Farbe	Schwarz

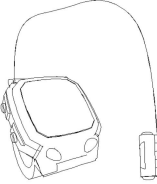



Modell	SSKM- 3
Produktgröße	1750*510*1360 mm
Farbe	Schwarz

## TEILELISTE

			
A x1	B x2	C x2	D x1
			
E x1	F x2	G x2	H x2
 M8*80mm			
J x4	K x2	L x1	M x1
			

N x4	P x2	Q x3	T x4
		 M8*25 mm	
U x1	M8*60mm S x20	V x16	W x2
			
		R x50	Y x1

## MONTAGESTRITT S

<b>SCHRITT 1</b>									
	E	X1	F	X2	G	X2	P	X2	R



S	X2
---	----

Die Höhe des Laufbands kann mit dem Teil P verstellt werden.

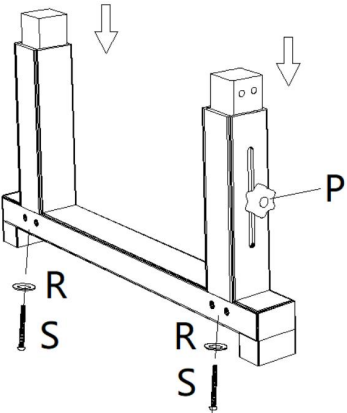

**SCHRI  
TT 2**



A

X1

H

X2

R

X12

V

X12

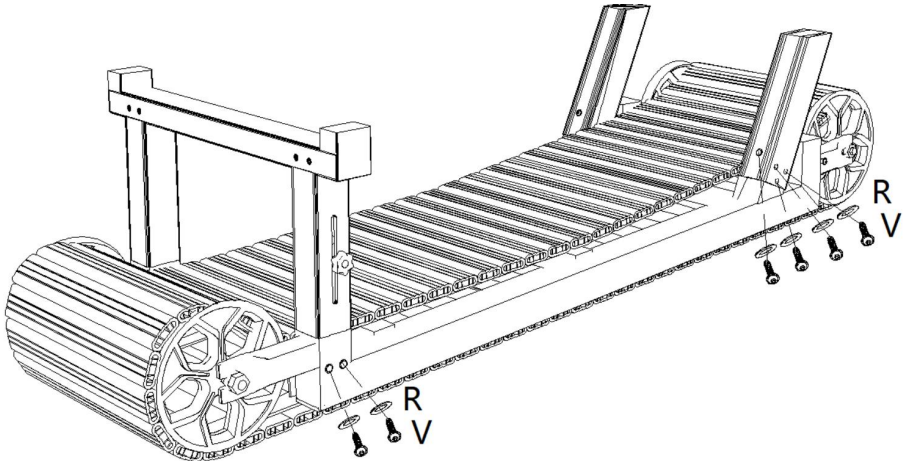

**SCHRI  
TT 3**



B

X2



R

X4



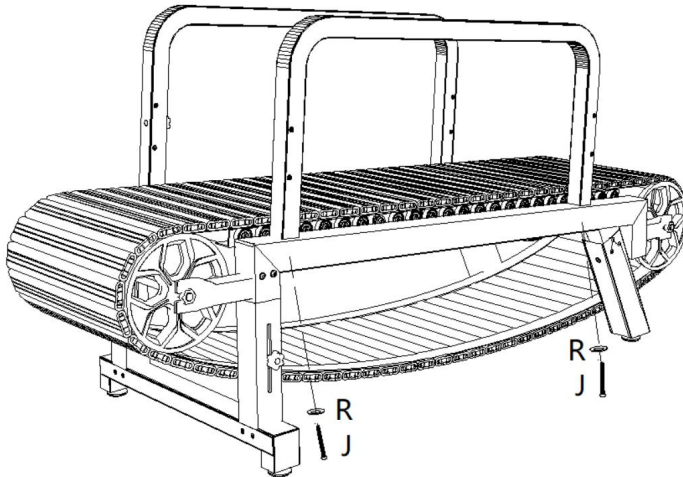

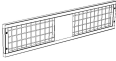
J

X4

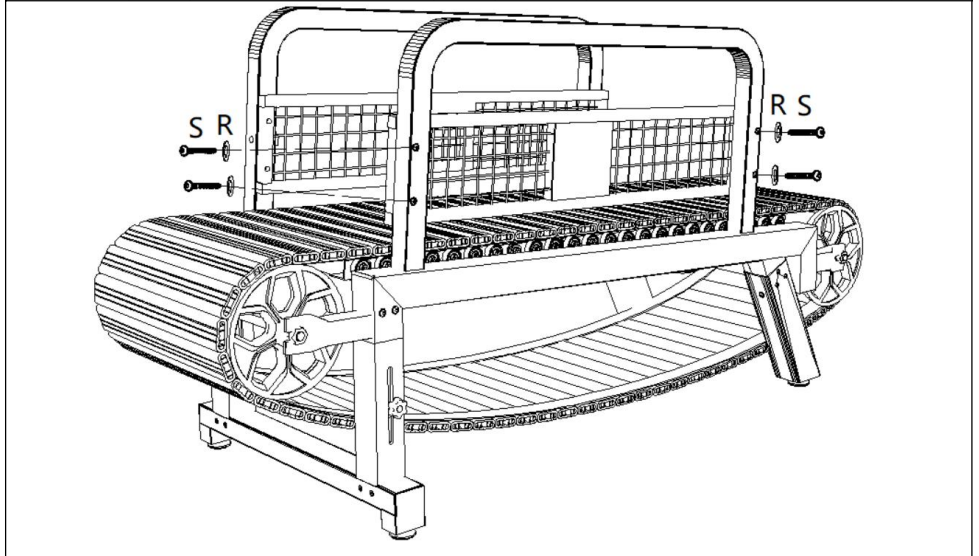

<b>SCHRI TT 4</b>								
	C	X2	R	X8	S	X8		



<b>SCHRI TT 5</b>										
	D	X1	L	X1	M	X1	N	X4	R	X14

Komponente M kann oben (Position) oder auf Komponente L befestigt werden.

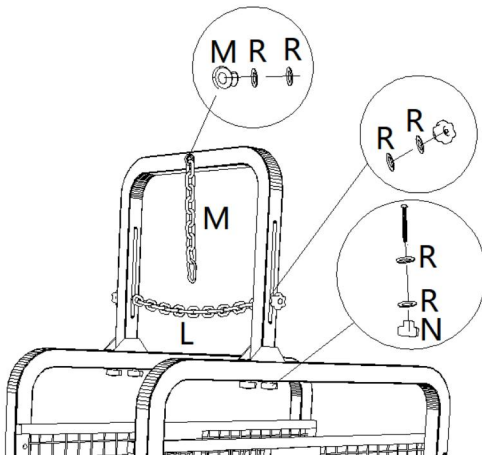

**SCHRI  
TT 6**

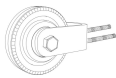



K

X2

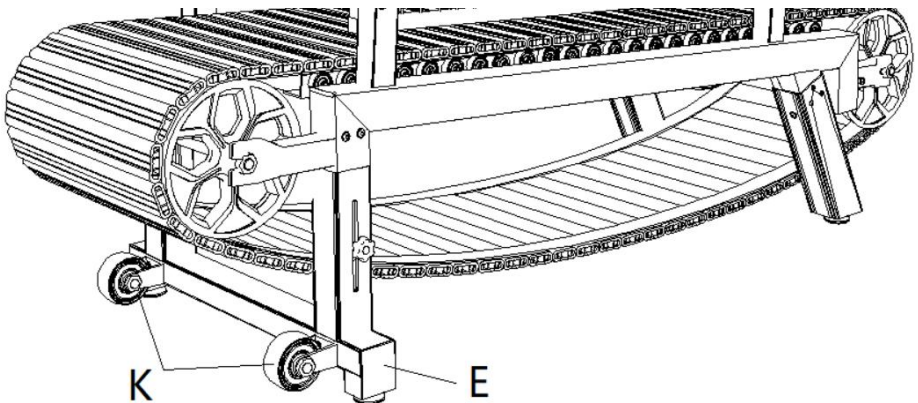
Die Mutter vom Bauteil K entfernen, durch die Halterung E führen und dann die Mutter festziehen.



**SCHRI  
TT 7**

			
T	X1	U	X1

Montieren Sie den Sensor bündig an der in der Abbildung gezeigten Position. Führen Sie das abgehende Kabel durch den Schlitz und achten Sie bei der Installation darauf, dass das Kabel nicht mit dem rotierenden Rad in Berührung kommt.

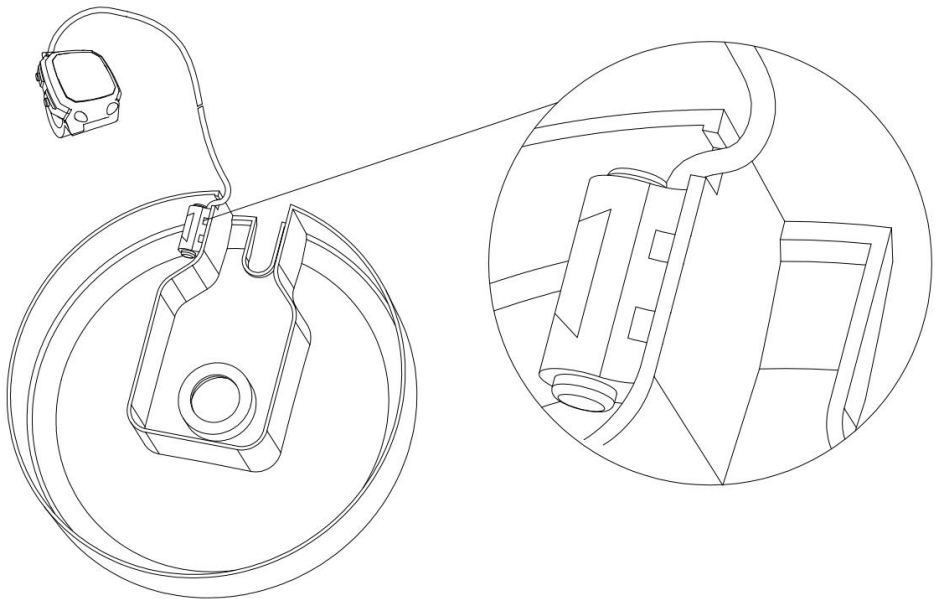

**SCHRI  
TT 8**



T

X4

V

X4

R

X4

Q

X2

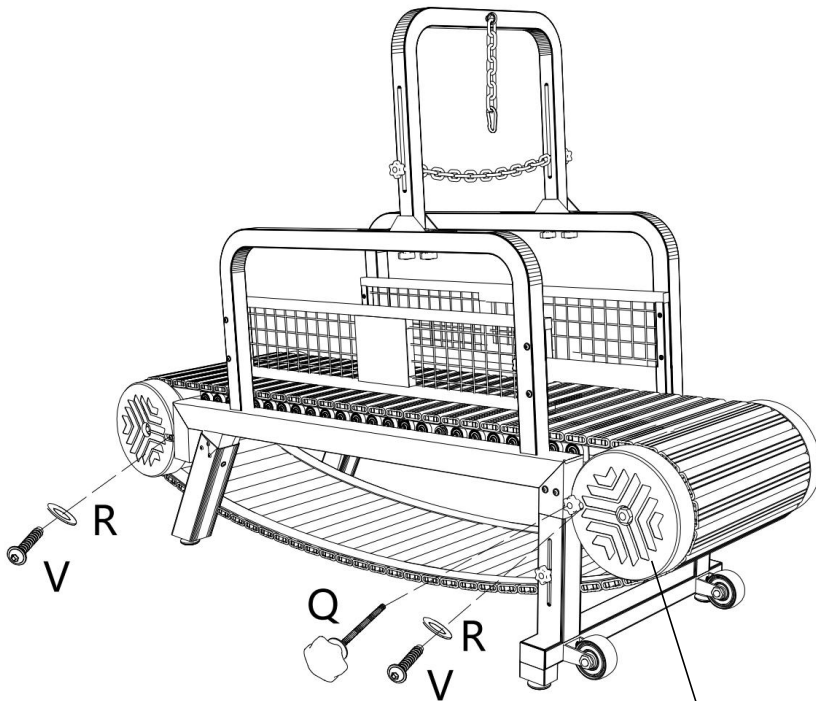

Bauen Sie das Bauteil T (mit Sensor ausgestattet) aus dem vorherigen Schritt 7 an dieser Position ein.

Der Laufwiderstand des Laufbandes kann durch die Einstellschraube des Teils Q angepasst werden.

**SCHRI  
TT 9**



Q

X1

R

X1

U

X1

Montieren Sie die Bremse und befestigen Sie den Kilometerzähler.

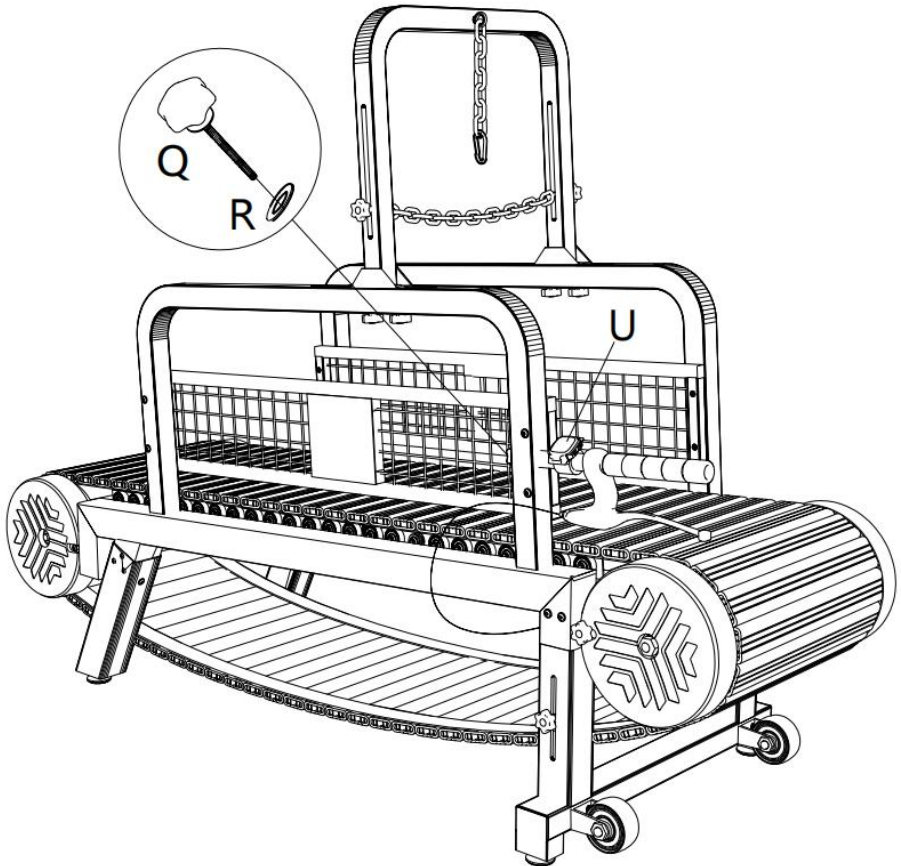

**Hersteller :** Shanghaimuxinmuyeyouxiangongsi

**Adresse:** Shuangchenglu 803nong11hao1602A700 x 450 x 12451609shi,  
baoshanqu, Shanghai 200000 CN.

**Importiert nach Australien:** SIHAO PTY LTD. 1 ROKEVA STREET,  
EASTWOOD NSW 2122, Australien

**Importiert in die USA:** Sanven Technology Ltd. Suite 250, 9166 Anaheim  
Ort, Rancho Cucamonga, CA 91730



E-CrossStu GmbH

Mainzer Landstr.69, 60329 Frankfurt am Main.



YH CONSULTING LIMITED.

C/O YH Consulting Limited Office 147, Centurion House,  
London Road, Staines-upon-Thames, Surrey, TW18 4AX





# VEVOR

**Upgrade · The Home Creator Way**

Tapis roulant pour chien

**MODÈLE : SSKL-3 SSKM-3**

MODÈLE : SSKL-3 SSKM-3

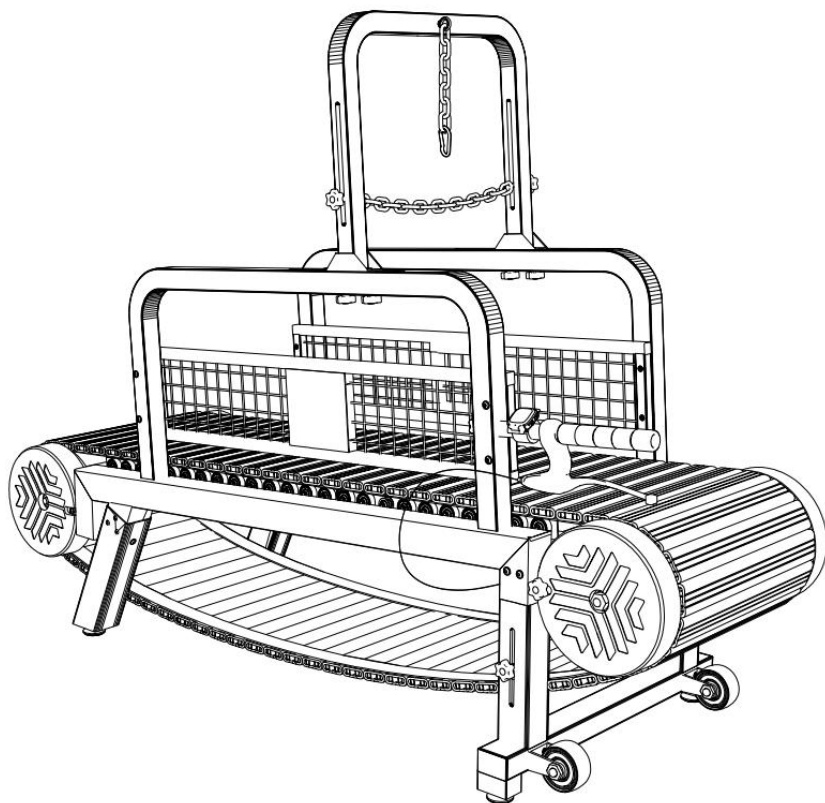

Voici les instructions originales. Veuillez lire attentivement toutes les instructions du manuel avant utilisation. VEVOR se réserve le droit d'interpréter ce manuel à sa guise. L'apparence du produit que vous recevrez peut différer. Nous vous prions de nous excuser si nous vous informons des mises à jour techniques ou logicielles concernant notre produit.

# Manuel d'utilisation du tapis roulant pour chien

## Informations importantes relatives à la sécurité :

- Lire toutes les instructions avant d'utiliser le tapis roulant .
- Ne pas utiliser le tapis roulant malade si votre chien a-t-il des problèmes de santé ou blessures qui peuvent être exacerbés par l'exercice physique.
- Surveillez toujours votre chien lorsqu'il utilise le tapis roulant .
- Gardez les enfants et les autres animaux domestiques éloignés du tapis roulant lorsqu'il est utilisé. utiliser .
- Connectez votre chien au tapis roulant je vais par le harnais plutôt que par un collier .
- Utiliser le tapis roulant en bref Faites des intervalles (pas plus de 20 minutes d'affilée, avec 10 minutes de course et 10 minutes de marche séparées) pour éviter que votre chien n'ait trop chaud ou ne s'épuise. Réduisez le temps si votre Le chien n'est pas en grande forme ou ne semble pas à l'aise .

## Utilisation du tapis roulant :

9. Autorisez votre chien à Explorez la machine et habituez votre chien à l'utiliser . Il suffit qu'il se sente à l'aise debout ou assis dessus. il.

10. Attachez votre chien au tapis roulant avec le harnais. Ne comptez jamais sur eux pour deviner ce qui Soyez patient. Placez-vous devant eux et appelez-les. directement avec eux. Encouragez-les à bouger leurs pattes lentement. Ne vous inquiétez pas s'ils ne le font pas. Attendez, félicitez-les .

11. Répétez l'étape n° 2 jusqu'à ce qu'ils puissent marcher dessus par eux-mêmes. Faites - les toujours marcher. au lieu de Au début, faites-les courir . Cela peut les aider à s'habituer complètement à la machine. Après s'être familiarisé avec la machine , Encouragez-les à courir en vous plaçant devant eux et en les applaudissant ou en les appelant .

12. Une fois l'utilisation du tapis roulant terminée Nettoyez le tapis roulant.

## Entretien :

- Garder le tapis roulant propre et exempt de débris.
- Régulièrement inspecter la machine pour détecter les signes d'usure ou de dommage
- Lubrifiez le tapis roulant conformément aux instructions du fabricant.
- Rangez le tapis roulant dans un endroit sec et sûr lorsque Non utilisé.

## **INFORMATIONS FCC**

**PRUDENCE:** Les changements ou modifications non expressément approuvés par la partie responsable de la conformité pourraient annuler le droit de l'utilisateur à utiliser l'équipement !

Cet appareil est conforme à la partie 15 des règles de la FCC. Son fonctionnement est soumis aux deux conditions suivantes :

- 1) Ce produit peut provoquer des interférences nuisibles.
- 2) Ce produit doit accepter toute interférence reçue, y compris les interférences pouvant entraîner un fonctionnement indésirable.

**AVERTISSEMENT:** Toute modification apportée à ce produit sans l'approbation expresse de la partie responsable de la conformité pourrait annuler le droit de l'utilisateur à utiliser le produit.

**Note:** Ce produit a été testé et déclaré conforme aux limites applicables aux appareils numériques de classe B, conformément à la partie 15 de la réglementation de la FCC. Ces limites sont conçues pour offrir une protection raisonnable contre les interférences nuisibles dans une installation résidentielle.

Ce produit génère, utilise et peut émettre de l'énergie radiofréquence. S'il n'est pas installé et utilisé conformément aux instructions, il peut causer des interférences nuisibles aux communications radio. Toutefois, il n'existe aucune garantie que des interférences ne se produiront pas dans une installation particulière. Si ce produit cause des interférences nuisibles à la réception radio ou télévisée (ce qui peut être déterminé en l'éteignant et en le rallumant), l'utilisateur est invité à essayer de corriger ces interférences en appliquant une ou plusieurs des mesures suivantes.

- Réorienter ou déplacer l'antenne de réception.
- Augmenter la distance entre le produit et le destinataire.
- Branchez le produit sur une prise de courant d'un circuit différent de celui auquel le récepteur est branché.
- Consultez votre revendeur ou un technicien radio/TV expérimenté pour obtenir de l'aide.



## WARNING!

**INGESTION HAZARD:** This product contains a button cell or coin battery.  
**DEATH** or serious injury can occur if ingested.  
A swallowed button cell or coin battery can cause internal **Chemical Burns** in as little as **2 hours**.  
KEEP new and used batteries **OUT OF REACH of CHILDREN**.  
**Seek immediate medical attention** if a battery is suspected to be swallowed or inserted inside any part of the body.



## WARNING!

**INGESTION HAZARD:** This product contains a button cell or coin battery.  
**DEATH** or serious injury can occur if ingested.  
A swallowed button cell or coin battery can cause internal **Chemical Burns** in as little as **2 hours**.  
KEEP new and used batteries **OUT OF REACH of CHILDREN**.  
**Seek immediate medical attention** if a battery is suspected to be swallowed or inserted inside any part of the body.











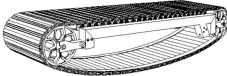

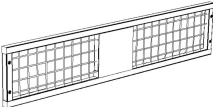
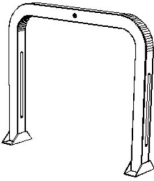
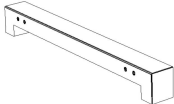

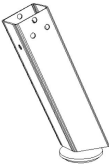

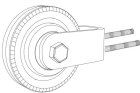

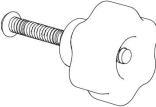

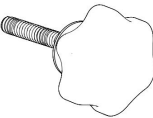
## CARACTÉRISTIQUES

Modèle	SSKL- 3
Taille du produit	1910*570*1400 mm
Couleur	Noir





Modèle	SSKM- 3
Taille du produit	1750*510*1360 mm
Couleur	Noir

## LISTE DES PIÈCES

 <p>A x1</p>	 <p>B x2</p>	 <p>C x2</p>	 <p>D x1</p>
 <p>E x1</p>	 <p>F x2</p>	 <p>G x2</p>	 <p>H x2</p>
 <p>M8*80 mm</p> <p>J x4</p>	 <p>K x2</p>	 <p>L x1</p>	 <p>M x1</p>
 <p>N x4</p>	 <p>P x2</p>	 <p>Q x3</p>	 <p>T x4</p>
		 <p>M8*25 mm</p>	

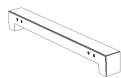
	M8*60 mm	V x16	W x2
U x1	S x20	 R x50	 Y x1

## ÉTAPE D'ASSEMBLAGE S

ÉTAPE 1									
	E	X1	F	X2	G	X2	P	X2	R

La hauteur du tapis roulant peut être réglée par la pièce P

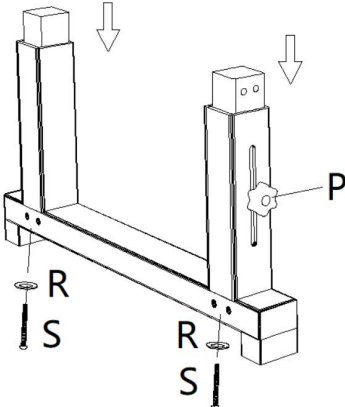

	
S	X2

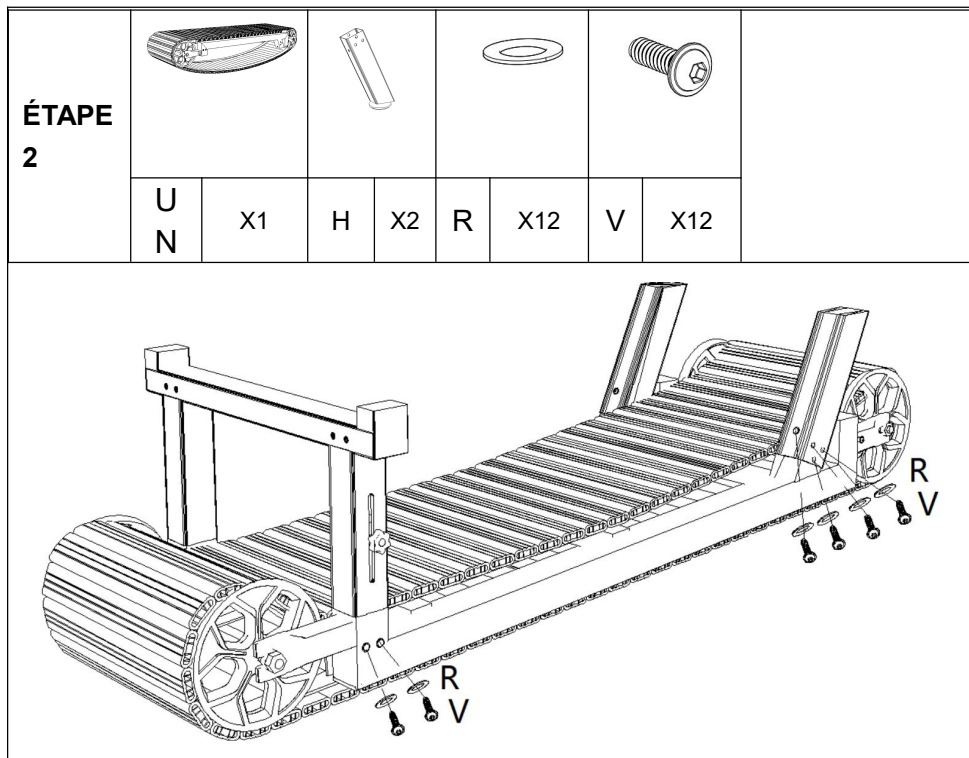



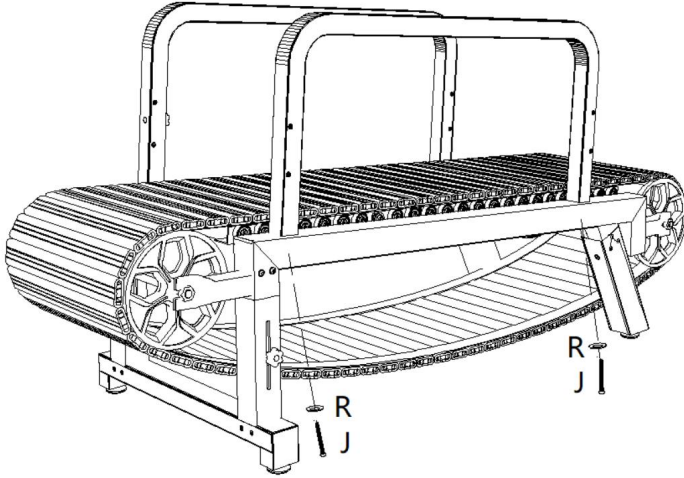

<b>ÉTAPE</b> <b>3</b>						
	B	X2	R	X4	J	X4

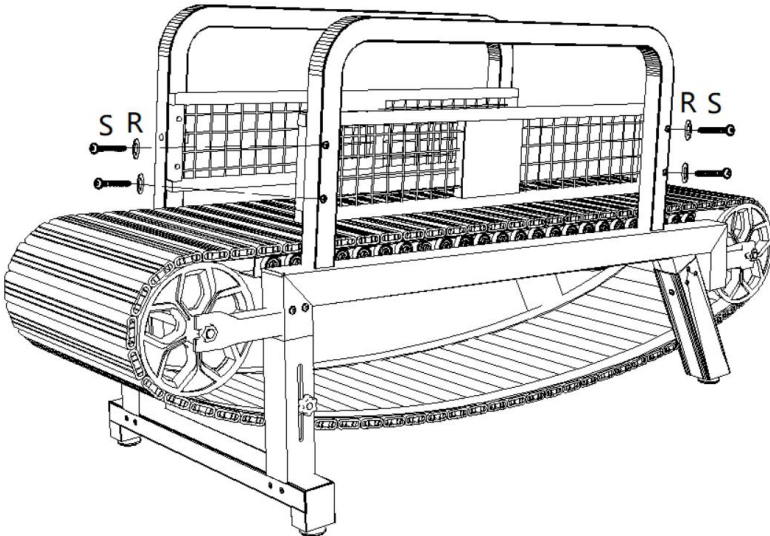



<b>ÉTAPE</b> <b>4</b>						
	C	X2	R	X8	S	X8

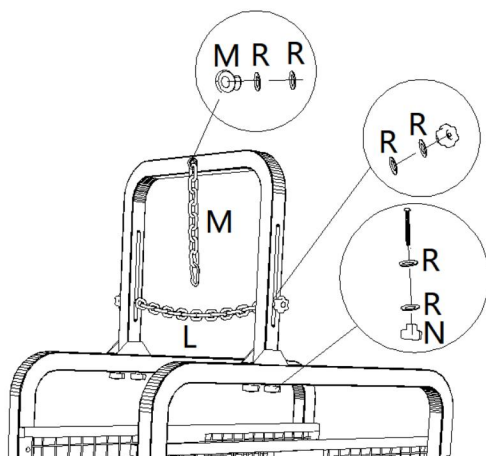

<b>ÉTAPE</b> <b>5</b>										
	D	X1	L	X1	M	X1	N	X4	R	X14

Le composant M peut être fixé sur le dessus (position) ou sur le composant L.



<b>ÉTAPE</b> <b>6</b>		
	K	X2

Retirez l'écrou du composant K, faites-le passer à travers le support E, puis serrez l'écrou.

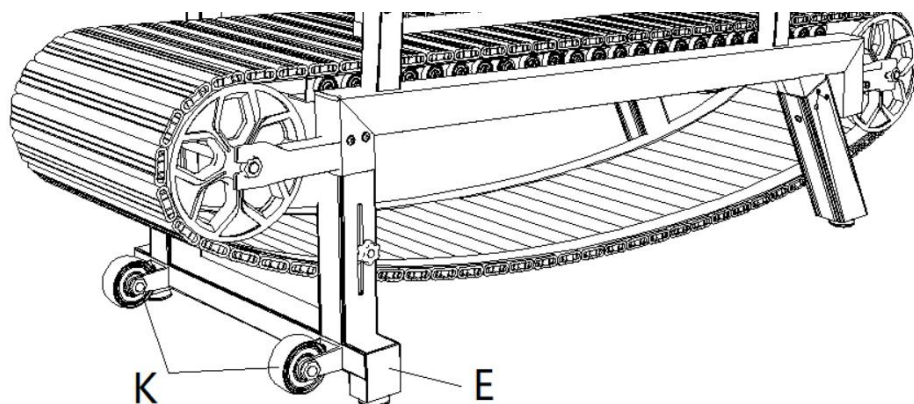

**ÉTAPE**  
**7**



T

X1

U

X1

Installez le capteur à fleur de l'emplacement indiqué sur le schéma. Faites passer le fil sortant par la fente et, lors de l'installation, veillez à ce qu'il n'entre pas en contact avec la roue en rotation.

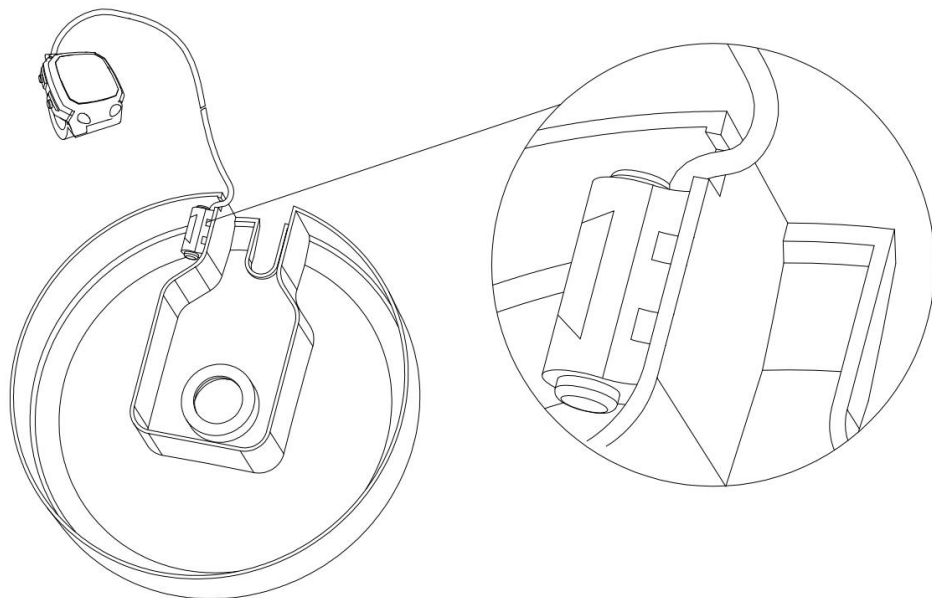

**ÉTAPE**  
**8**



T

X4

V

X4

R

X4

Q

X2

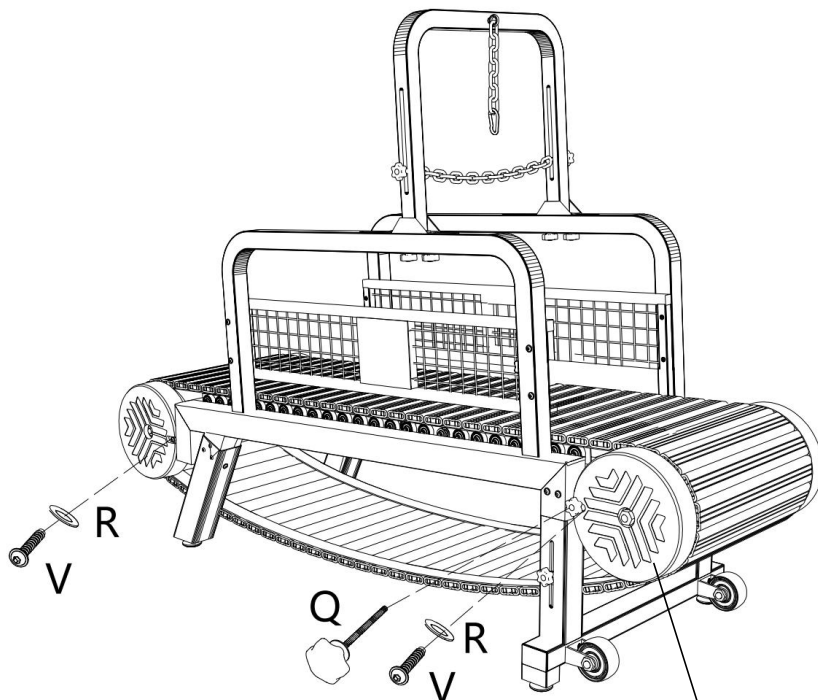

Installez le composant T (équipé d'un capteur) de l'étape 7 précédente à cet emplacement.

La résistance à la course du tapis roulant peut être ajustée par le réglage de la tension de la pièce Q.

**ÉTAPE**  
**9**



Q

X1

R

X1

U

X1

Installez le frein et fixez le compteur kilométrique.

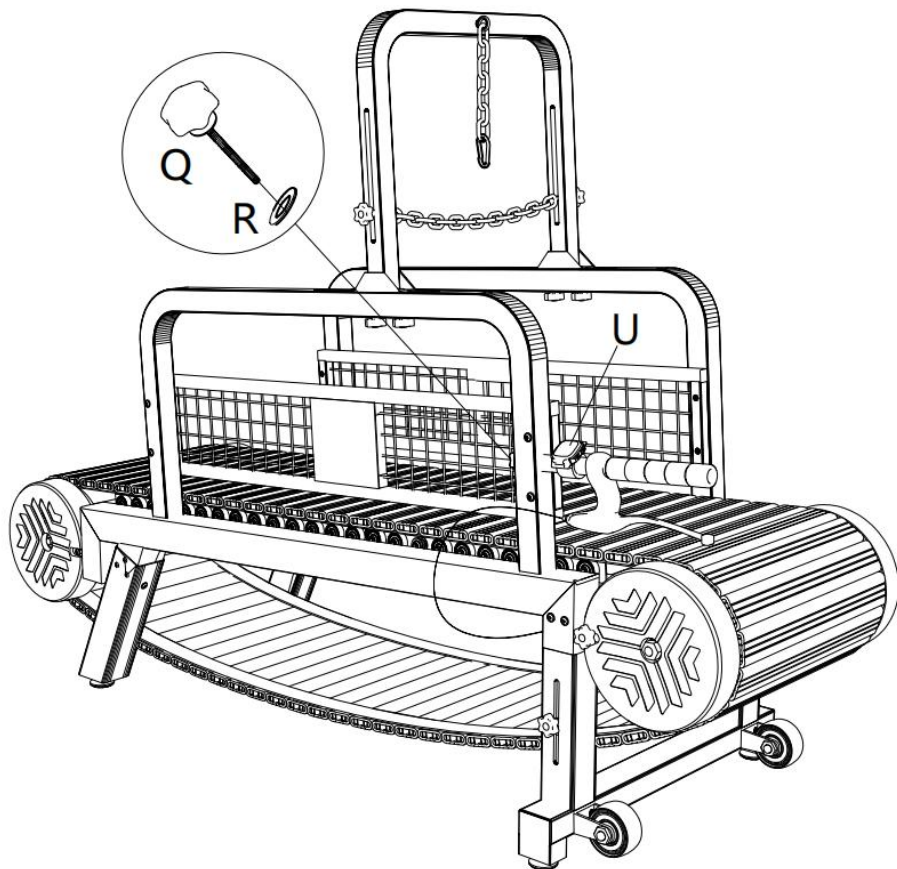

**Fabricant** : Shanghaimuxinmuyeyouxiangongsi

**Adresse** : Shuangchenglu 803nong11hao1602A700 x 450 x 12451609shi,  
baoshanqu, shanghai 200000 CN.

**Importé en Australie** : SIHAO PTY LTD. 1 ROKEVA STREET, ESTWOOD  
NSW 2122, Australie

**Importé aux États-Unis** : Sanven Technology Ltd., Suite 250, 9166  
Anaheim

Rancho Cucamonga, CA 91730

<b>EC</b>	<b>REP</b>
-----------	------------

E-CrossStu GmbH

Mainzer Landstr.69, 60329 Frankfurt am Main.

<b>UK</b>	<b>REP</b>
-----------	------------

YH CONSULTING LIMITED.

C/O YH Consulting Limited Office 147, Centurion House,  
London Road, Staines-upon-Thames, Surrey, TW18 4AX





# VEVOR

**Upgrade · The Home Creator Way**

Hondenloopband

MODEL: SSKL-3 SSKM-3

**MODEL: SSKL-3 SSKM-3**

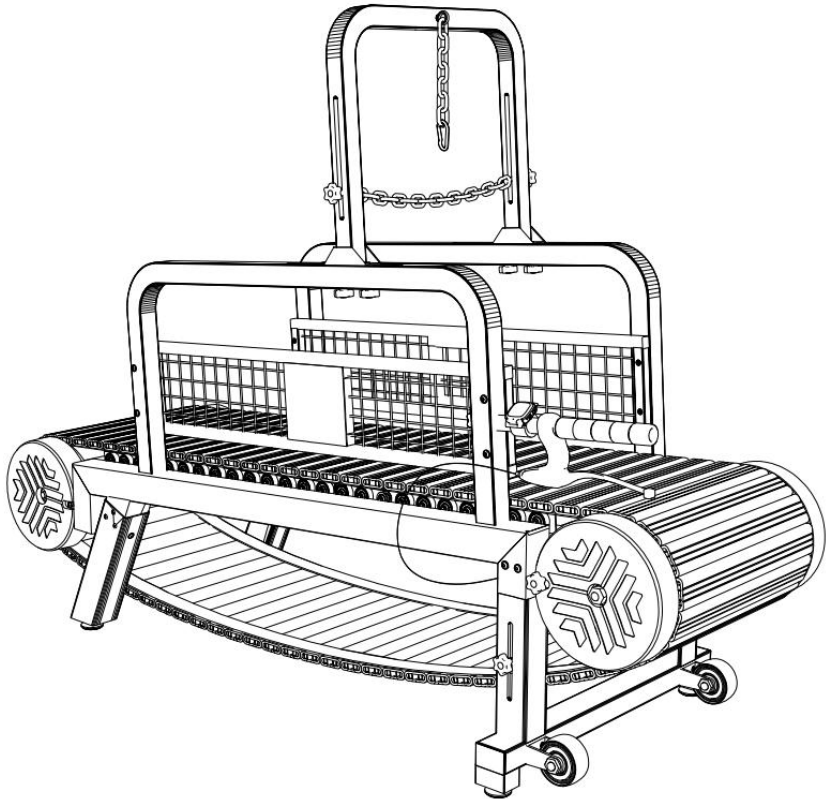

Dit is de originele handleiding. Lees alle instructies zorgvuldig door voordat u het product gebruikt. VEVOR behoudt zich het recht voor om de gebruiksaanwijzing duidelijk te interpreteren. Het uiterlijk van het product is afhankelijk van het product dat u hebt ontvangen. Neemt u het ons niet kwalijk dat we u niet meer op de hoogte stellen van eventuele technologische of software-updates voor ons

product.

## Handleiding voor de hondenloopband

### Belangrijke veiligheidsinformatie:

- Lees alles instructies voordat u de loopband gebruikt .
- Niet gebruiken de treadmill ziek als uw hond heeft gezondheidsproblemen of verwondt die door lichaamsbeweging kunnen verergeren.
- Houd altijd toezicht op uw hond wanneer u de loopband gebruikt .
- Houd kinderen en andere huisdieren uit de buurt van de loopband wanneer deze in gebruik is. gebruik .
- Sluit uw hond naar de treadmill door het tuig in plaats van een halsband .
- Gebruik de loopband kortom intervallen (niet langer dan 20 minuten per keer, met 10 minuten rennen en 10 minuten wandelen ertussen) om te voorkomen dat uw hond oververhit of uitgeput raakt. Verkort de tijd die u nodig heeft hond is niet in goede conditie of voelt zich ongemakkelijk .

### De loopband gebruiken:

13. Laat uw hond ontdek de machine en laat uw hond eraan wennen . Door ze simpelweg comfortabel te laten staan of zitten Het.

14. Bevestig uw hond aan de loopband met het harnas om. Vertrouw er nooit op dat zij zullen uitvinden wat om nog even geduld te hebben. Ga voor hen staan en bel hen rechtstreeks. Moedig ze aan om hun poten langzaam te bewegen. Maak je geen zorgen als ze dat niet doen. Wacht, geef ze een compliment .

15. Herhaal stap 2 tot ze erop kunnen lopen door henzelf. Zorg ervoor dat ze altijd rondlopen in plaats van Laat ze eerst even rennen . Dit kan hen helpen om helemaal aan de machine te wennen. Nadat u vertrouwd bent geraakt met de machine, Moedig ze aan om te rennen door voor ze te gaan staan en te applaudisseren of door ze naar je toe te roepen.

16. Wanneer u klaar bent met het gebruik van de loopband Maak de loopband schoon.

### Onderhoud :

- Houden de loopband schoon en vrij van brokstukken.
- Regelmatig Controleer de machine op tekenen van slijtage of schade
- Smeer de loopband zoals aangegeven door de fabrikant.
- Bewaar de loopband in A droge en veilige locatie wanneer niet in gebruik.

## **FCC INFORMATIE**

**VOORZICHTIGHEID:** Wijzigingen of aanpassingen die niet uitdrukkelijk zijn goedgekeurd door de partij die verantwoordelijk is voor de naleving, kunnen de bevoegdheid van de gebruiker om het apparaat te bedienen ongeldig maken!

Dit apparaat voldoet aan Deel 15 van de FCC-regels. Gebruik is onderworpen aan de volgende twee voorwaarden:

- 1) Dit product kan schadelijke interferentie veroorzaken.
- 2) Dit product moet alle ontvangen interferentie accepteren, inclusief interferentie die een ongewenste werking kan veroorzaken.

**WAARSCHUWING:** Wijzigingen of aanpassingen aan dit product die niet uitdrukkelijk zijn goedgekeurd door de partij die verantwoordelijk is voor de naleving, kunnen de bevoegdheid van de gebruiker om het product te bedienen ongeldig maken.

**Opmerking:** Dit product is getest en voldoet aan de limieten voor een digitaal apparaat van klasse B, conform Deel 15 van de FCC-regels.

Deze limieten zijn bedoeld om redelijke bescherming te bieden tegen schadelijke interferentie in een woonomgeving.

Dit product genereert, gebruikt en kan radiofrequentie-energie uitstralen.

Indien niet geïnstalleerd en gebruikt volgens de instructies, kan het schadelijke interferentie veroorzaken in radiocommunicatie. Er is echter geen garantie dat er in een bepaalde installatie geen interferentie zal optreden. Als dit product schadelijke interferentie veroorzaakt in radio- of televisieontvangst, wat kan worden vastgesteld door het product uit en weer in te schakelen, wordt de gebruiker aangeraden de interferentie te verhelpen door een of meer van de volgende maatregelen te nemen.

- Heroriënteer of verplaats de ontvangstantenne.
- Vergroot de afstand tussen het product en de ontvanger.
- Sluit het product aan op een stopcontact in een ander circuit dan waarop de ontvanger is aangesloten.
- Raadpleeg de dealer of een ervaren radio-/tv-technicus voor hulp.



## WARNING!

**INGESTION HAZARD:** This product contains a button cell or coin battery.  
**DEATH** or serious injury can occur if ingested.  
A swallowed button cell or coin battery can cause internal **Chemical Burns** in as little as **2 hours**.  
KEEP new and used batteries **OUT OF REACH of CHILDREN**.  
**Seek immediate medical attention** if a battery is suspected to be swallowed or inserted inside any part of the body.



## WARNING!

**INGESTION HAZARD:** This product contains a button cell or coin battery.  
**DEATH** or serious injury can occur if ingested.  
A swallowed button cell or coin battery can cause internal **Chemical Burns** in as little as **2 hours**.  
KEEP new and used batteries **OUT OF REACH of CHILDREN**.  
**Seek immediate medical attention** if a battery is suspected to be swallowed or inserted inside any part of the body.











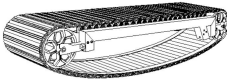

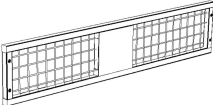
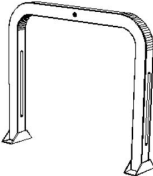
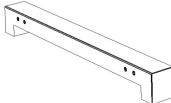

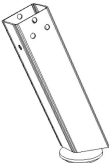

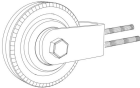

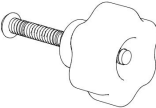

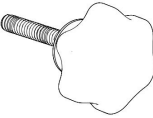
## SPECIFICATIES

Model	SSKL- 3
Productgrootte	1910*570*1400mm
Kleur	Zwart

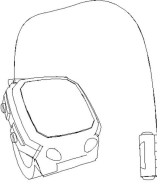





Model	SSKM- 3
Productgrootte	1750*510*1360mm
Kleur	Zwart

## ONDERDELENLIJST

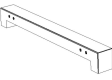
 <p>Een x1</p>	 <p>B x2</p>	 <p>C x2</p>	 <p>D x1</p>
 <p>E x1</p>	 <p>F x2</p>	 <p>G x2</p>	 <p>H x2</p>
 <p>M8*80mm</p> <p>J x4</p>	 <p>K x2</p>	 <p>L x1</p>	 <p>M x1</p>
 <p>N x4</p>	 <p>P x2</p>	 <p>Q x3</p>	 <p>T x4</p>

 <b>U x1</b>	 <b>M8*60mm</b> <b>S x20</b>	 <b>M8*25 mm</b> <b>V x16</b>	 <b>B x2</b>
		 <b>R x50</b>	 <b>Y x1</b>

## MONTAGESTAP S

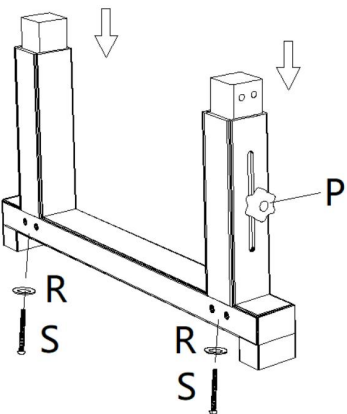
<b>STAP</b> <b>1</b>										
	<b>E</b>	<b>X1</b>	<b>F</b>	<b>X2</b>	<b>G</b>	<b>X2</b>	<b>P</b>	<b>X2</b>	<b>R</b>	<b>X2</b>
	<p>De hoogte van de loopband is verstelbaar door middel van onderdeel P</p> 									
<b>S</b>	<b>X2</b>									

**STAP  
2**



A

X1

H

X2

R

X12

V

X12

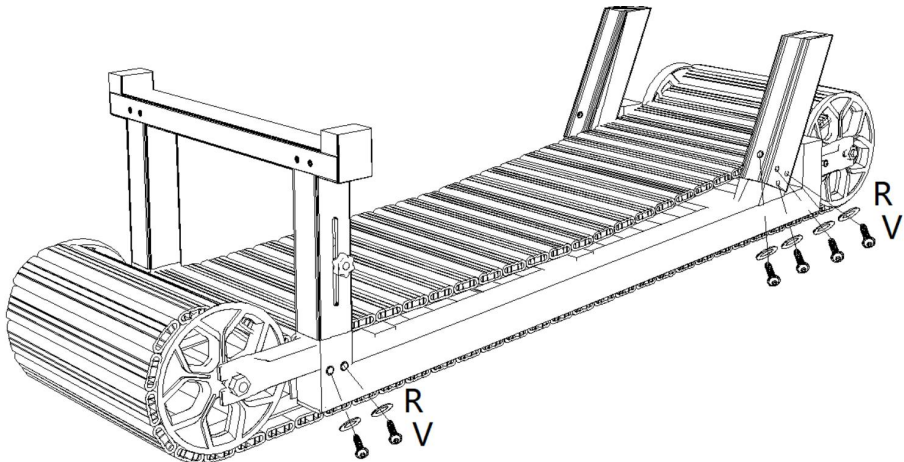

**STAP  
3**



B

X2



R

X4



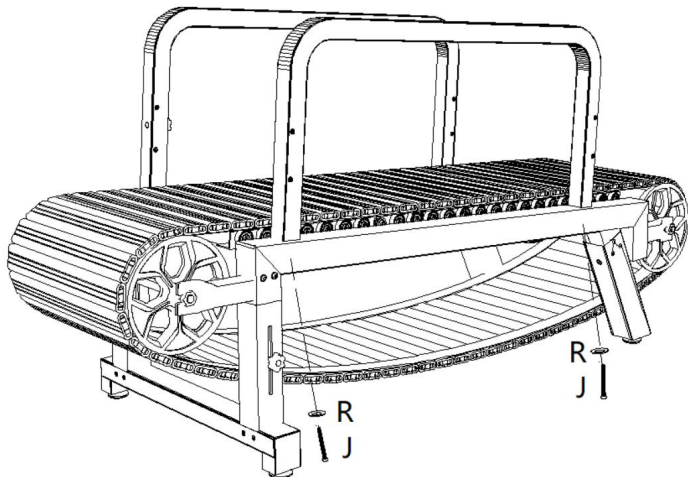

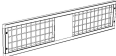
J

X4

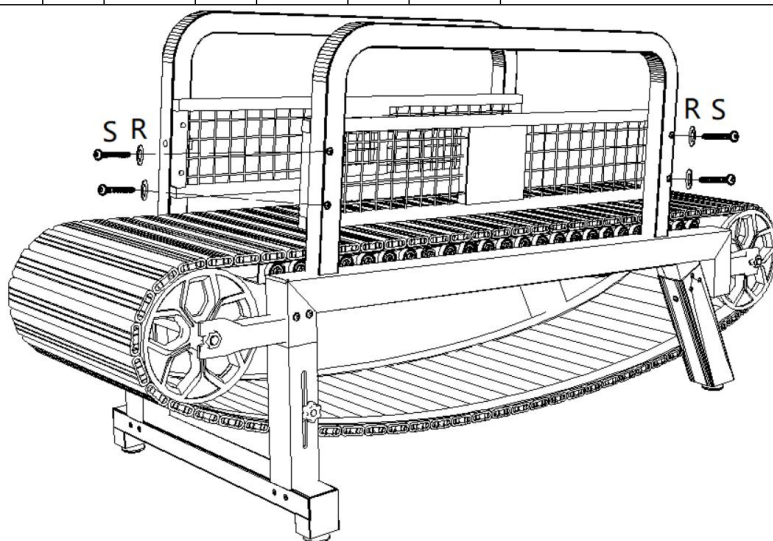

<b>STAP 4</b>								
	C	X2	R	X8	S	X8		



<b>STAP 5</b>										
	D	X1	L	X1	M	X1	N	X4	R	X14

Component M kan bovenop (positie) of op component L worden bevestigd.

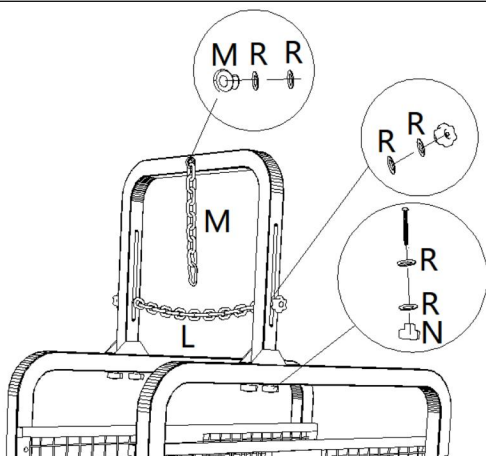

**STAP  
6**

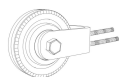

K

X2

Verwijder de moer van onderdeel K, steek deze door beugel E en draai de moer vervolgens vast.

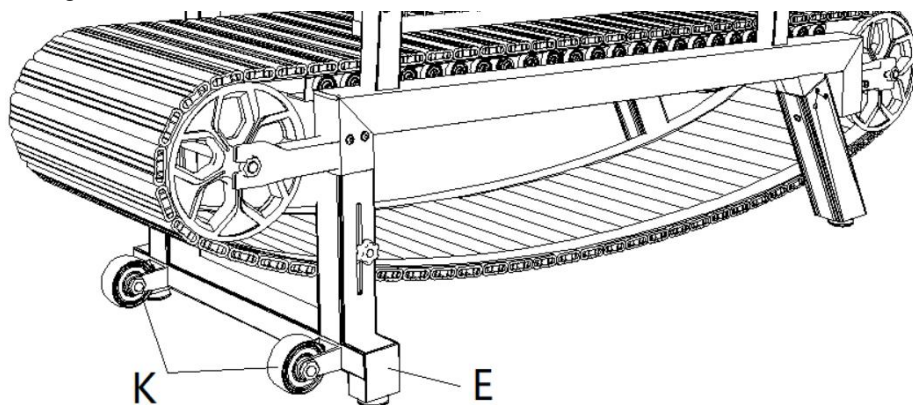

**STAP  
7**



T

X1

jij

X1

Installeer de sensor vlak op de positie die in het schema is aangegeven. Leid de uitgaande draad door de sleuf en zorg er tijdens de installatie voor dat de draad niet in contact komt met het draaiende wiel.

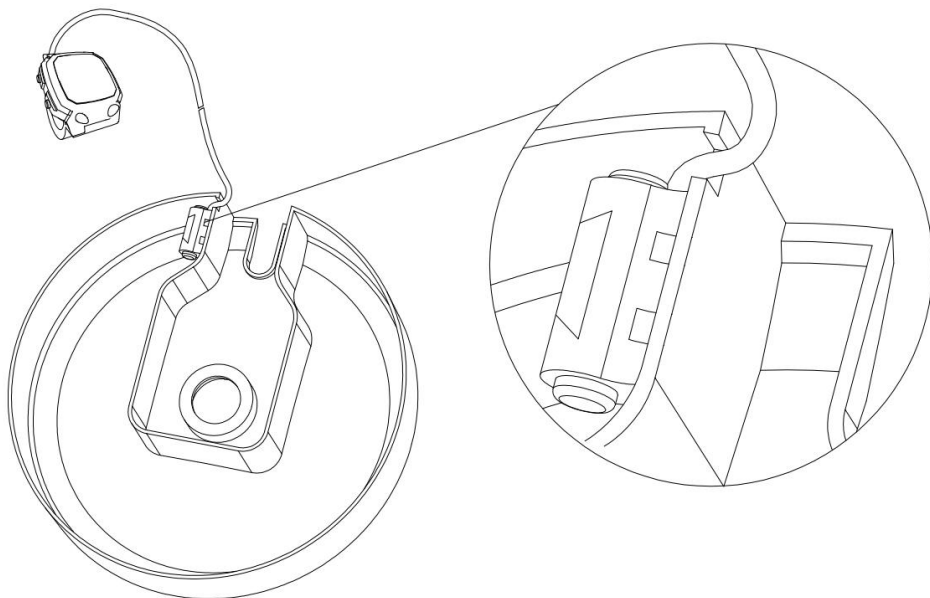

**STAP  
8**



T

X4

V

X4

R

X4

Q

X2

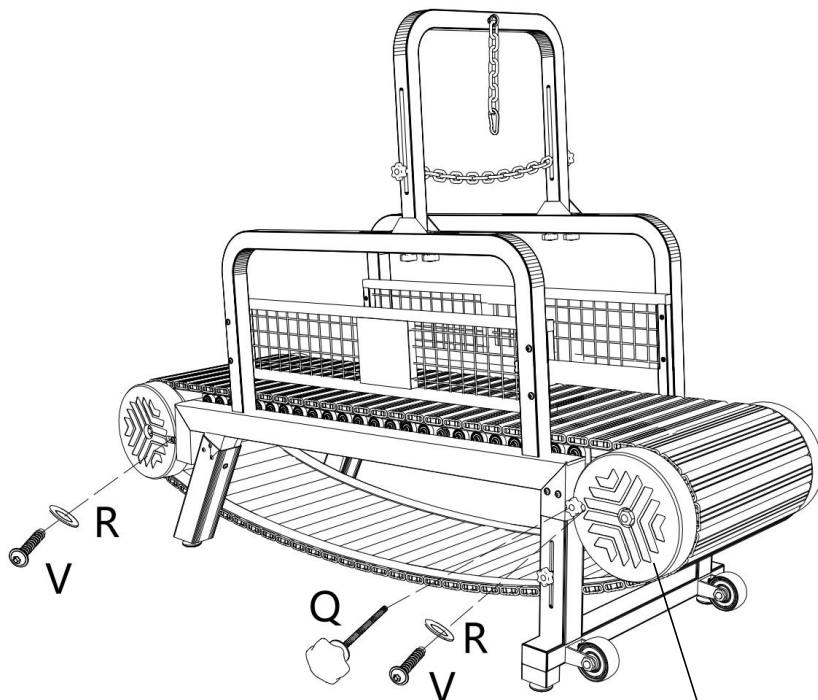

Installeer component T (voorzien van een sensor) uit de vorige stap 7 op deze positie.

De loopweerstand van de loopband kan worden aangepast door de stevigheidsinstelling van onderdeel Q.

**STAP  
9**



Q

X1

R

X1

jij

X1

Monteer de rem en zet de kilometerteller vast.

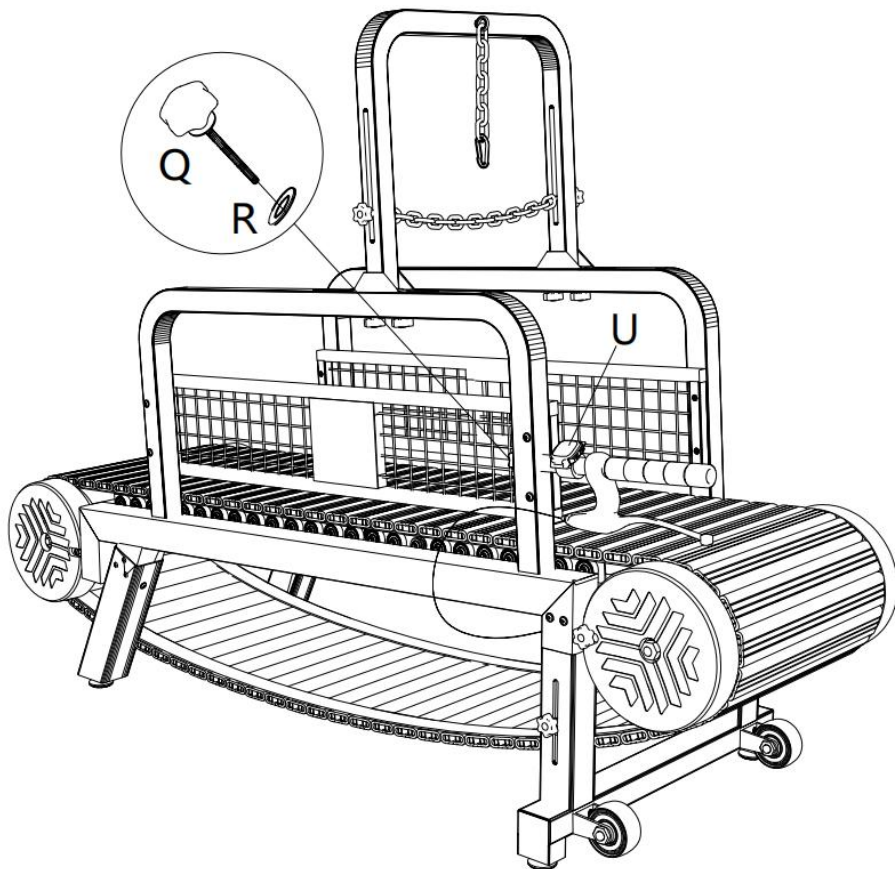

**Fabrikant :** Shanghaimuxinmuyeyouxiangongsi

**Adres:** Shuangchenglu 803nong11hao1602A700 x 450 x 12451609shi,  
baoshanqu, shanghai 200000 CN.

**Geïmporteerd naar AUS:** SIHAO PTY LTD. 1 ROKEVA  
STREETEASTWOOD NSW 2122 Australië

**Geïmporteerd naar de VS:** Sanven Technology Ltd. Suite 250, 9166  
Anaheim

Plaats, Rancho Cucamonga, CA 91730

<b>EC</b>	<b>REP</b>
-----------	------------

E-CrossStu GmbH

Mainzer Landstr.69, 60329 Frankfurt am Main.

<b>UK</b>	<b>REP</b>
-----------	------------

YH CONSULTING LIMITED.

C/O YH Consulting Limited Office 147, Centurion House,  
London Road, Staines-upon-Thames, Surrey, TW18 4AX





# VEVOR

**Upgrade · The Home Creator Way**

Hundlöpband

MODELL: SSKL-3 SSKM-3

**MODELL: SSKL-3 SSKM-3**

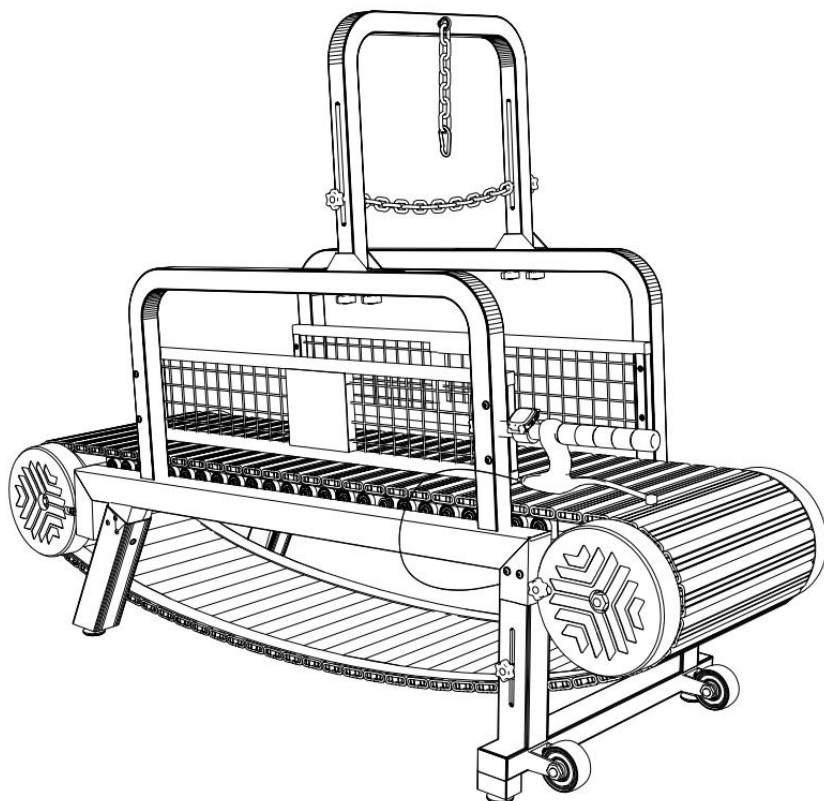

Detta är originalinstruktionerna, vänligen läs alla instruktioner noggrant innan du använder produkten. VEVOR förbehåller sig en tydlig tolkning av vår användarmanual. Produktens utseende ska vara beroende av den produkt du mottagit. Vi ber om ursäkt för att vi inte kommer att informera dig igen om det finns några teknik- eller programuppdateringar för vår produkt.

# Manuell instruktion för hundlöpband

## Viktig säkerhetsinformation:

- Läs alla instruktionerna innan du använder löpbandet .
- Använd inte löpbandet sjukt om din hund har några hälsoproblem eller skador som kan förvärras av träning.
- Håll alltid uppsikt över din hund när du använder löpbandet .
- Håll barn och andra husdjur borta från löpbandet när det är i användning .
- Anslut din hund till löpbandet jag ska av selen snarare än ett halsband .
- Använda de löpband kort sagt intervaller (högst 20 minuter åt gången, med 10 minuters löpning och 10 minuters promenader separerade) för att förhindra att din hund blir överhettad eller utmattad. Minska tiden du behöver för att Hunden är inte i bra skick eller känner sig obekvämt .

## Använda löpbandet:

17. Låt din hund Utforska maskinen och låt din hund vänja sig vid den. Låt den helt enkelt känna sig bekväm när den står eller sitter på den. det.

18. Fäst din hund på löpbandet med selen på. Lita aldrig på dem för att lista ut vad att göra bara ännu ha tålamod. Placera dig framför dem och ring dem direkt. Uppmuntra dem att röra sina tasslar långsamt. Oroa dig inte om de inte gör det. Vänta, ge dem beröm .

19. Upprepa steg #2 tills de kan gå på den av sig själva. Håll dem alltid gående i stället för springa i början . Detta kan hjälpa dem att vänja sig vid maskinen helt och hållet . Efter att ha blivit bekant med maskinen , Uppmuntra dem att springa genom att stå framför dem och applådera eller kalla dem till dig.

20. När du är klar med löpbandet städa upp löpbandet.

## Underhåll :

- Behåll löpbandet rent och fritt från skräp.
- Regelbundet inspektera maskinen för tecken på slitage eller skada
- Smörj löpbandet enligt tillverkarens anvisningar .
- Förvara löpbandet i en torr och säker plats när inte i bruk.

## FCC - INFORMATION

**FÖRSIKTIGHET:** Ändringar eller modifieringar som inte uttryckligen godkänts av den part som ansvarar för efterlevnaden kan upphäva användarens rätt att använda utrustningen!

Denna enhet uppfyller del 15 i FCC-reglerna. Användning är underkastad följande två villkor:

- 1) Denna produkt kan orsaka skadliga störningar.
- 2) Denna produkt måste acceptera alla mottagna störningar, inklusive störningar som kan orsaka oönskad drift.

**WARNING:** Ändringar eller modifieringar av denna produkt som inte uttryckligen godkänts av den part som ansvarar för efterlevnaden kan upphäva användarens rätt att använda produkten.

**Notera:** Denna produkt har testats och befunnits uppfylla gränserna för en digital enhet av klass B i enlighet med del 15 i FCC-reglerna. Dessa gränser är utformade för att ge rimligt skydd mot skadlig störning i en bostadsinstallation.

Denna produkt genererar, använder och kan utstråla radiofrekvensenergi, och om den inte installeras och används i enlighet med instruktionerna kan den orsaka skadliga störningar på radiokommunikation. Det finns dock ingen garanti för att störningar inte kommer att uppstå i en viss installation. Om denna produkt orsakar skadliga störningar på radio- eller tv-mottagning, vilket kan fastställas genom att stänga av och slå på produkten, uppmanas användaren att försöka korrigera störningen med en eller flera av följande åtgärder.

- Rikta om eller flytta mottagarantennen.
- Öka avståndet mellan produkten och mottagaren.
- Anslut produkten till ett uttag på en annan krets än den som mottagaren är ansluten till.
- Kontakta återförsäljaren eller en erfaren radio-/TV-tekniker för hjälp.



## WARNING!

**INGESTION HAZARD:** This product contains a button cell or coin battery.  
**DEATH** or serious injury can occur if ingested.  
A swallowed button cell or coin battery can cause internal **Chemical Burns** in as little as **2 hours**.  
KEEP new and used batteries **OUT OF REACH of CHILDREN**.  
**Seek immediate medical attention** if a battery is suspected to be swallowed or inserted inside any part of the body.



## WARNING!

**INGESTION HAZARD:** This product contains a button cell or coin battery.  
**DEATH** or serious injury can occur if ingested.  
A swallowed button cell or coin battery can cause internal **Chemical Burns** in as little as **2 hours**.  
KEEP new and used batteries **OUT OF REACH of CHILDREN**.  
**Seek immediate medical attention** if a battery is suspected to be swallowed or inserted inside any part of the body.











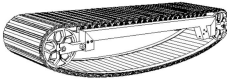

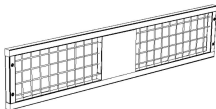
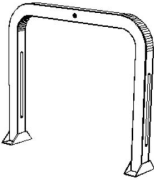
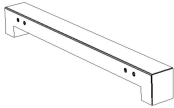

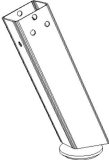

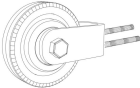

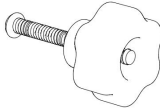
## SPECIFIKATIONER

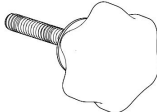
Modell	SSKL- 3
Produktstorlek	1910*570*1400 mm
Färg	Svart

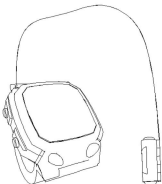
Modell	SSKM- 3
Produktstorlek	1750*510*1360 mm
Färg	Svart

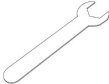
# DELLISTA

 <p>En x1</p>	 <p>B x2</p>	 <p>C x2</p>	 <p>D x1</p>
 <p>E x1</p>	 <p>F x2</p>	 <p>G x2</p>	 <p>H x2</p>
 <p>M8*80mm J x4</p>	 <p>K x2</p>	 <p>L x1</p>	 <p>M x1</p>
 <p>N x4</p>	 <p>P x2</p>	 <p>Q x3</p>	 <p>T x4</p>
 <p>U x1</p>	 <p>M8*60mm S x20</p>	 <p>M8*25 mm V x16</p>	 <p>B x2</p>
		 <p>R x50</p>	 <p>Y x1</p>

# MONTERINGSSTEG S

<b>STEG1</b>										
	E	X1	F	X2	G	X2	P	X2	R	X2
		Löpbandets höjd kan justeras med del P								
S	X2									

**STEG2**

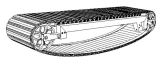

En

X1

H

X2

R

X12

V

X12

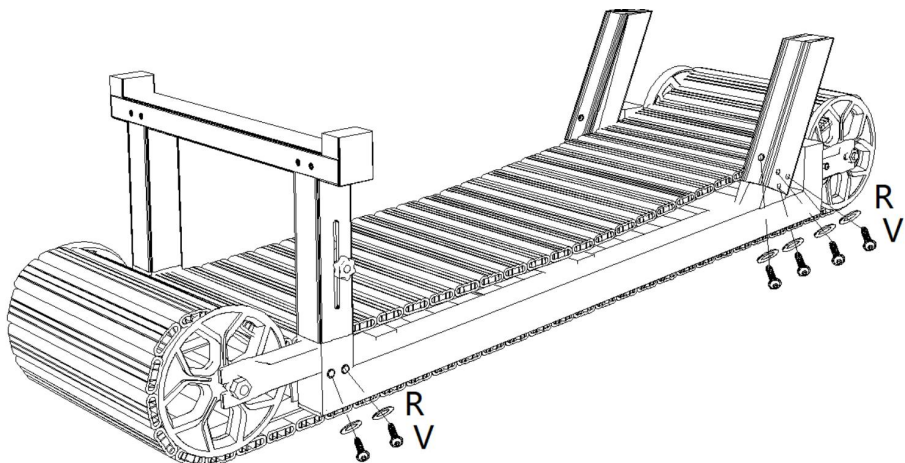

**STEG3**



B

X2



R

X4



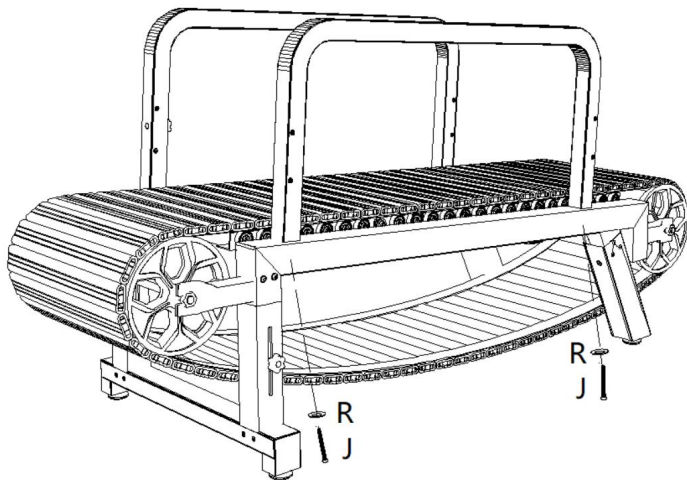

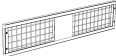
J

X4

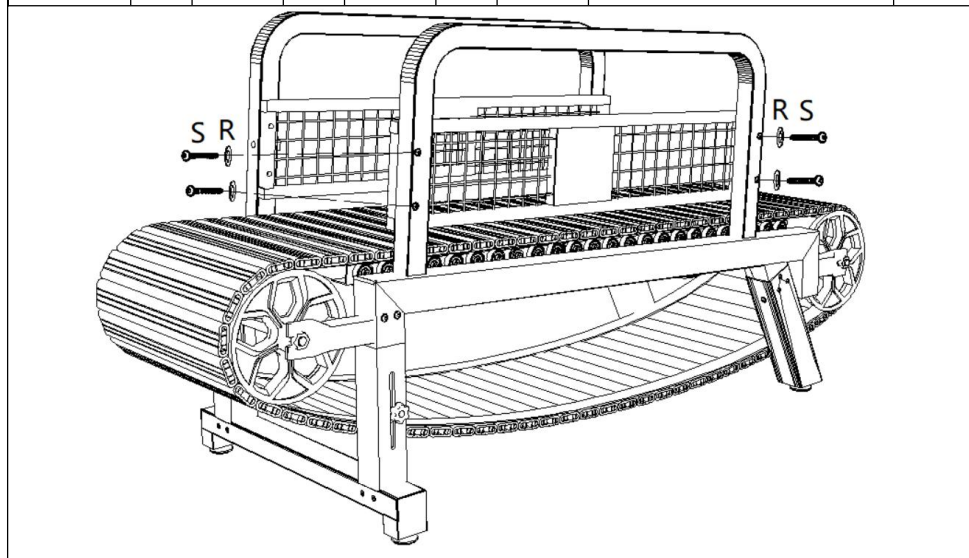

<b>STEG4</b>								
	C	X2	R	X8	S	X8		



<b>STEG5</b>										
	D	X1	L	X1	M	X1	N	X4	R	X14

Komponent M kan fästas på toppen (position) eller på komponent L.

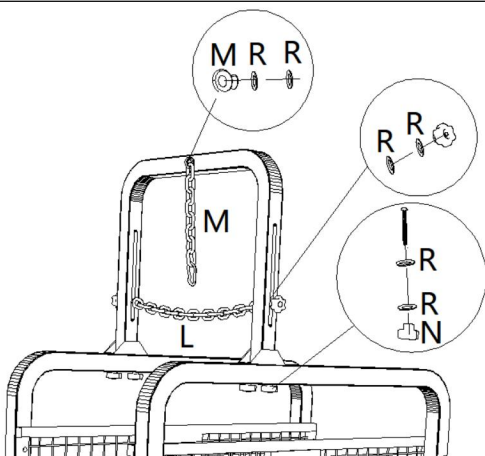

**STEG6**

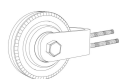

K

X2

Ta bort muttern från komponent K, för den genom fästet E och dra sedan åt muttern.

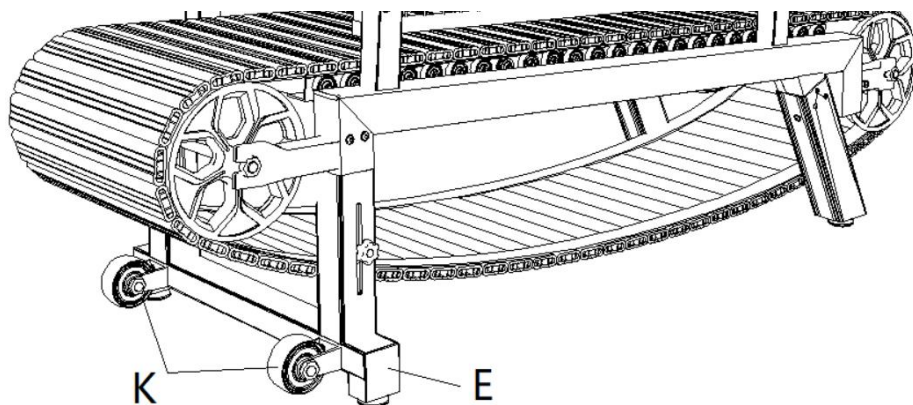

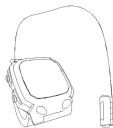
**STEG 7**

T

X1

U

X1

Montera sensorn i jämnhöjd med den position som visas i diagrammet. Dra den utgående kabeln genom springan och se till att kabeln inte kommer i kontakt med det roterande hjulet under installationen.

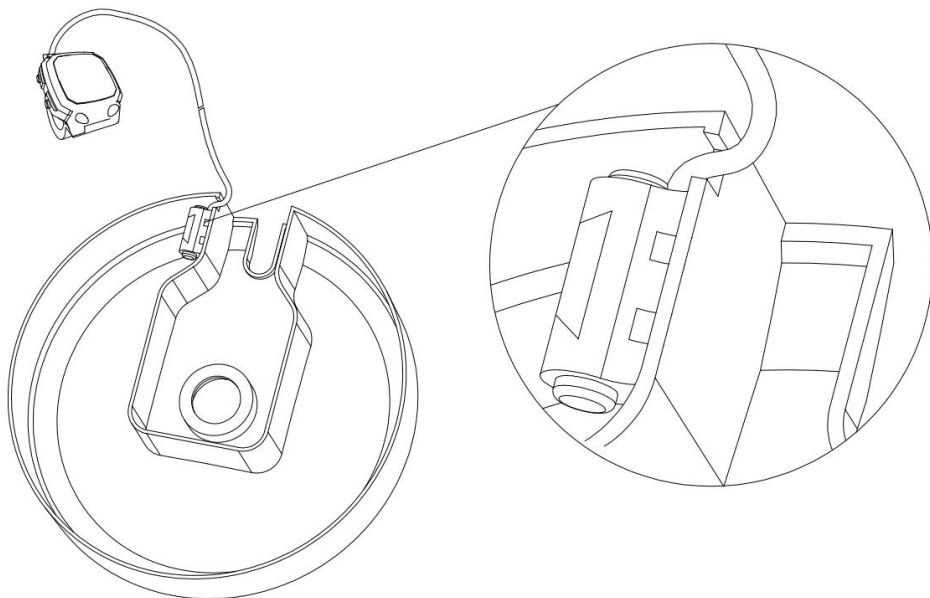

**STEG 8**

T

X4

V

X4

R

X4

Q

X2

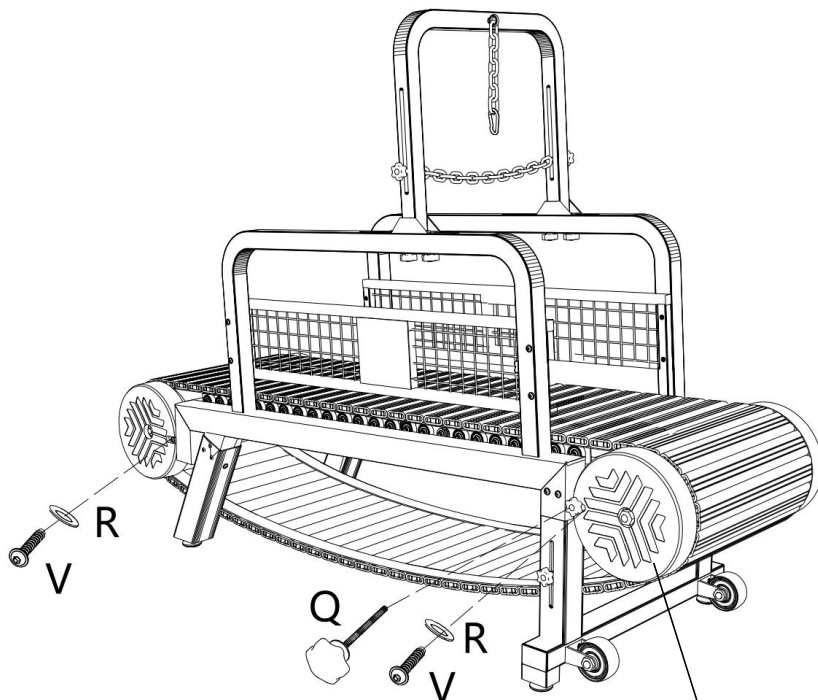

Montera komponent T (utrustad med en sensor) från föregående steg 7 på denna position.

Löpbåndets löpmotstånd kan justeras med hjälp av spänningsjusteringen i del Q.

**STEG9**

Q

X1

R

X1

U

X1

Montera bromsen och säkra vägmätaren.

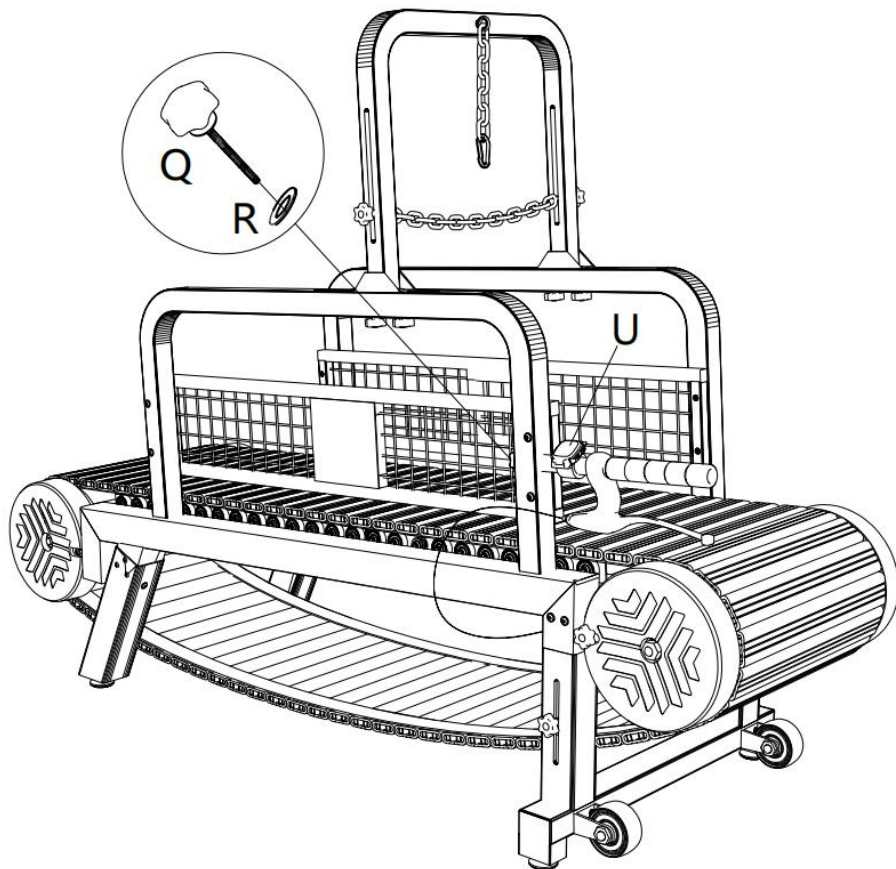

**Tillverkare :** Shanghaimuxinmuyeyouxiangongsi

**Adress:** Shuangchenglu 803nong11hao1602A700 x 450 x 12451609shi,  
baoshanqu, shanghai 200000 CN.

**Importerad till Australien:** SIHAO PTY LTD. 1 ROKEVA  
STREETEASTWOOD NSW 2122 Australien

**Importerad till USA:** Sanven Technology Ltd. Suite 250, 9166 Anaheim  
Plats, Rancho Cucamonga, Kalifornien 91730



E-CrossStu GmbH

Mainzer Landstr.69, 60329 Frankfurt am Main.



YH CONSULTING LIMITED.

C/O YH Consulting Limited Office 147, Centurion House,  
London Road, Staines-upon-Thames, Surrey, TW18 4AX





# VEVOR

**Upgrade · The Home Creator Way**

Cinta de correr para perros

MODELO: SSKL-3 SSKM-3

**MODELO: SSKL-3 SSKM-3**

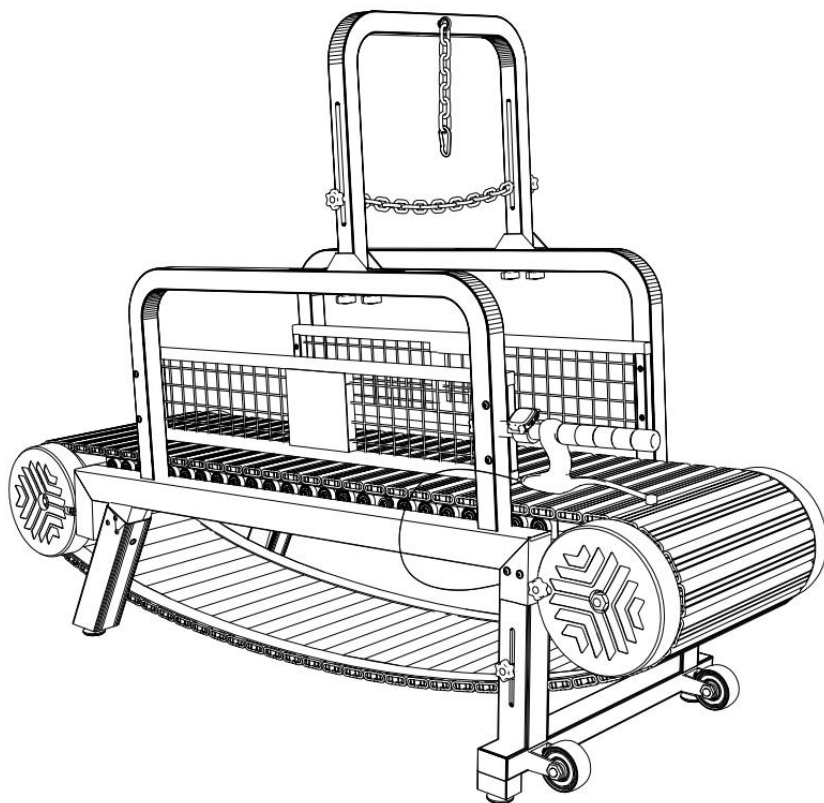

Estas son las instrucciones originales. Lea atentamente todas las instrucciones del manual antes de usar el producto. VEVOR se reserva el derecho de interpretar este manual de usuario. El aspecto del producto puede variar. Le pedimos disculpas por no informarle sobre actualizaciones de tecnología o software de nuestro producto.

# Manual de instrucciones de la cinta de correr para perros

## Información importante de seguridad:

- Lea todo Instrucciones antes de usar la cinta de correr.
- No usar el andar mal si ¿ Su perro tiene algún problema de salud ? lesiones que puede verse exacerbada por el ejercicio.
- Supervise siempre a su perro cuando utilice la cinta de correr .

Mantenga a los niños y otras mascotas alejados de la cinta de correr cuando esté en uso.  
usar .

- Conecta tu perro a la cinta transportadora lo haré por el arnés en lugar de un collar .
- Usar el rueda de andar en breve Intervalos (no más de 20 minutos seguidos, con 10 minutos de carrera y 10 minutos de caminata separados) para evitar que tu perro se acalore o se agote. Reduce el tiempo si tu perro... El perro no está en buenas condiciones o se siente incómodo .

## Usando la cinta de correr:

21. Permite que tu perro Explora la máquina y acostumbra a tu perro a ella . Simplemente logra que se sienta cómodo de pie o sentado sobre ella. él.

22. Sujeta a tu perro a la cinta de correr con el arnés puesto. Nunca confíes en ellos para averiguar qué Aún no lo hagas, ten paciencia. Colócate frente a ellos y llámalos. directamente a ellos. Anímalos a mover las patas despacio. No te preocupes si no lo hacen. Espera y elógielos .

23. Repita el paso n.º 2 hasta que puedan caminar sobre ella por sí mismos. Siempre manténgalos caminando. en lugar de Al principio , pueden empezar a usar la máquina. Esto les ayudará a familiarizarse completamente con ella. Tras familiarizarme con la máquina ,

Anímalos a correr poniéndote frente a ellos y aplaudiéndolos o llamándolos hacia ti.

24. Cuando termine de usar la cinta de correr Limpia la cinta de correr.

## Mantenimiento :

- Mantener la cinta de correr limpia y libre de escombros.
- Regularmente inspeccione la máquina para detectar signos de desgaste o roturas.  
daño
- Lubrique la cinta de correr según las instrucciones del fabricante.
- Guarda la cinta de correr en a lugar seco y seguro cuando No está en uso.

## **INFORMACIÓN DE LA FCC**

**PRECAUCIÓN:** ¡Los cambios o modificaciones no aprobados expresamente por la parte responsable del cumplimiento podrían anular la autorización del usuario para operar el equipo!

Este dispositivo cumple con la Parte 15 de las normas de la FCC. Su funcionamiento está sujeto a las dos condiciones siguientes:

- 1) Este producto puede causar interferencias perjudiciales.
- 2) Este producto debe aceptar cualquier interferencia recibida, incluyendo interferencias que puedan causar un funcionamiento no deseado.



**ADVERTENCIA:** Los cambios o modificaciones a este producto que no hayan sido expresamente aprobados por la parte responsable del cumplimiento podrían anular la autorización del usuario para operar el producto.



**Nota:** Este producto ha sido probado y cumple con los límites para un dispositivo digital de Clase B según la Parte 15 de las Normas de la FCC. Estos límites están diseñados para proporcionar una protección razonable contra interferencias perjudiciales en una instalación residencial.

Este producto genera, utiliza y puede irradiar energía de radiofrecuencia y, si no se instala y utiliza de acuerdo con las instrucciones, puede causar interferencias perjudiciales en las comunicaciones de radio. Sin embargo, no se garantiza que no se produzcan interferencias en una instalación en particular. Si este producto causa interferencias perjudiciales en la recepción de radio o televisión, lo cual se puede determinar apagando y encendiendo el producto, se recomienda al usuario que intente corregir la interferencia mediante una o más de las siguientes medidas.

- Reoriente o cambie de lugar la antena receptora.
- Aumentar la distancia entre el producto y el receptor.

- Conecte el producto a una toma de corriente de un circuito diferente al que está conectado el receptor.
- Consulte al distribuidor o a un técnico de radio/TV con experiencia para obtener ayuda.

 <b>WARNING!</b>	
<p><b>INGESTION HAZARD:</b> This product contains a button cell or coin battery. <b>DEATH</b> or serious injury can occur if ingested. A swallowed button cell or coin battery can cause internal <b>Chemical Burns</b> in as little as <b>2 hours</b>.  <b>KEEP</b> new and used batteries <b>OUT OF REACH of CHILDREN</b>.  <b>Seek immediate medical attention</b> if a battery is suspected to be swallowed or inserted inside any part of the body.</p>	









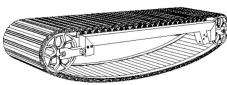
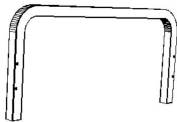
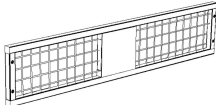
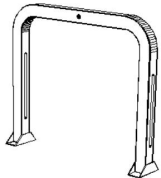
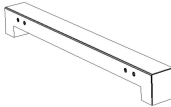

 <b>WARNING!</b>	
<p><b>INGESTION HAZARD:</b> This product contains a button cell or coin battery. <b>DEATH</b> or serious injury can occur if ingested. A swallowed button cell or coin battery can cause internal <b>Chemical Burns</b> in as little as <b>2 hours</b>.  <b>KEEP</b> new and used batteries <b>OUT OF REACH of CHILDREN</b>.  <b>Seek immediate medical attention</b> if a battery is suspected to be swallowed or inserted inside any part of the body.</p>	

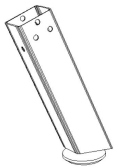

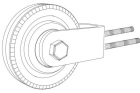

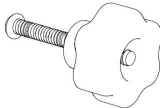

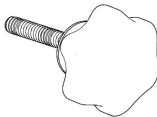
## PRESUPUESTO

Modelo	SSKL- 3
Tamaño del producto	1910*570*1400 mm
Color	Negro

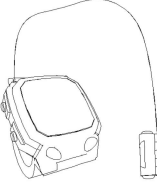





Modelo	SSKM- 3
Tamaño del producto	1750*510*1360 mm
Color	Negro

## LISTA DE PIEZAS

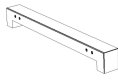
			
Un x1	B x2	C x2	D x1
			
E x1	F x2	G x2	H x2
			
M8*80 mm J x4	K x2	L x1	M x1
			

N x4	P x2	Q x3	T x4
		 M8*25 mm	
U x1	M8*60 mm	V x16	Ancho x2
	S x20		
		R x50	Y x1

## **PASO DE MONTAJE S**

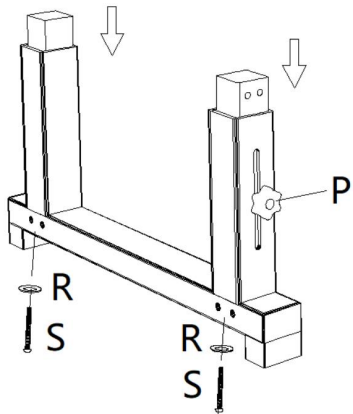
<b>PASO 1</b>										
	mi	X1	F	X2	GRAMO	X2	PAG	X2	R	X2
	La altura de la cinta de correr se puede ajustar mediante la pieza P.									
S	X2									

**PASO  
2**



A

X1

H

X2

R

X12

V

X12

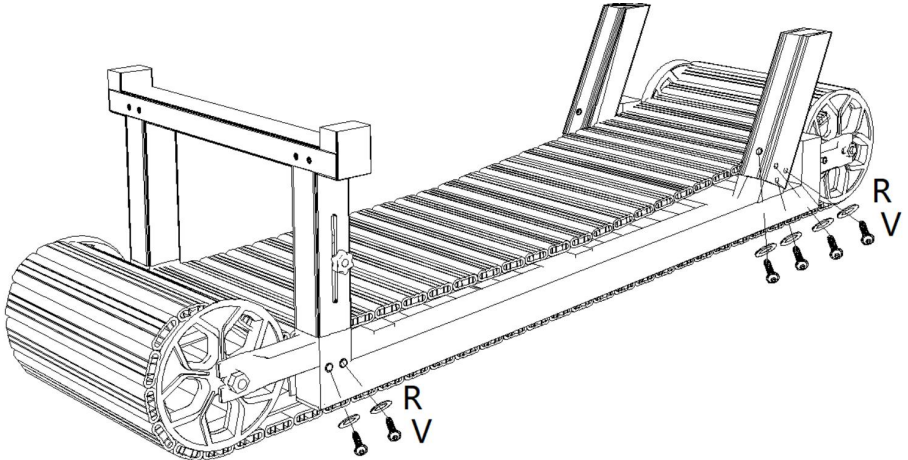

**PASO  
3**



B

X2



R

X4



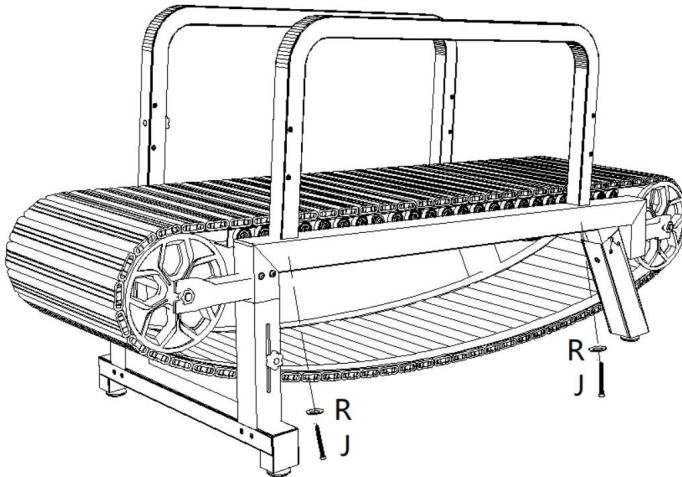

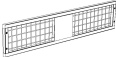
J

X4

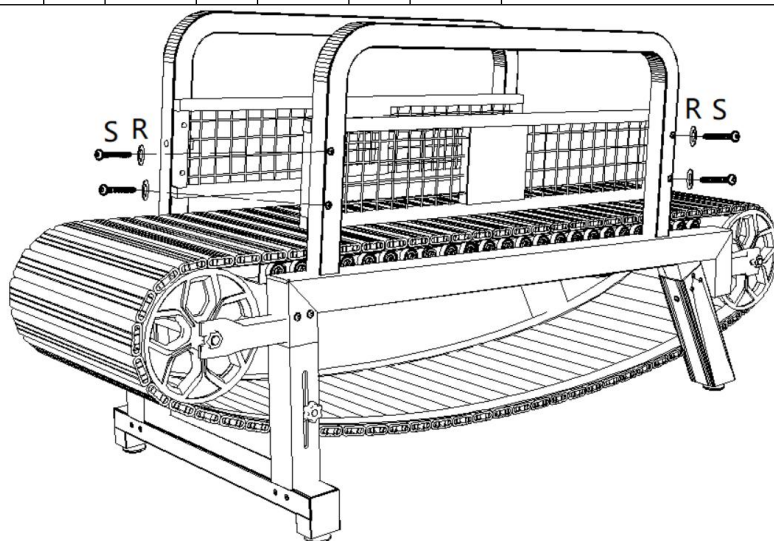

<b>PASO 4</b>								
	do	X2	R	X8	S	X8		



<b>PASO 5</b>										
	D	X1	L	X1	M E T R O	X1	no rte	X4	R	X14

El componente M se puede fijar en la parte superior (posición) o en el componente L.

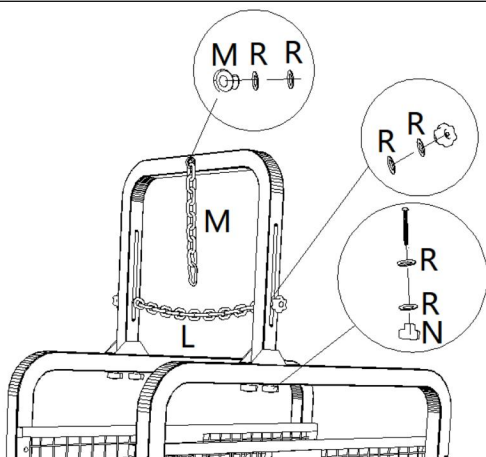

**PASO**  
**6**

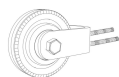

K X2

Retire la tuerca del componente K, pásela a través del soporte E y luego apriete la tuerca.

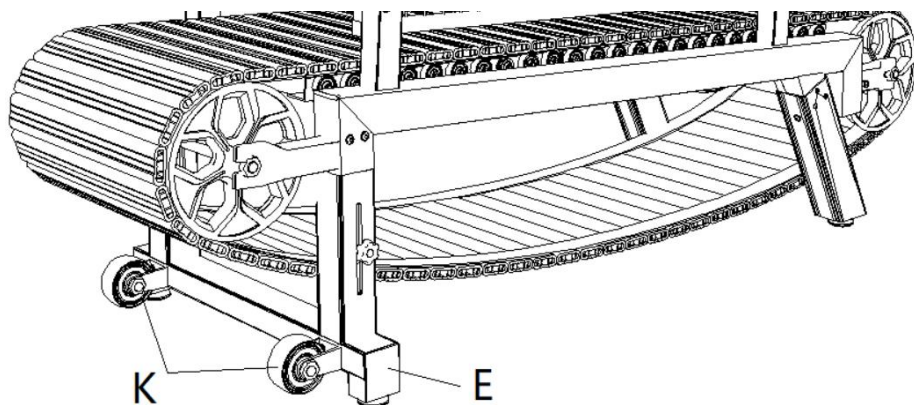

**PASO**  
**7**



T

X1

U

X1

Instale el sensor al ras con la posición que se muestra en el diagrama. Pase el cable de salida por la ranura y, durante la instalación, asegúrese de que el cable no entre en contacto con la rueda giratoria.

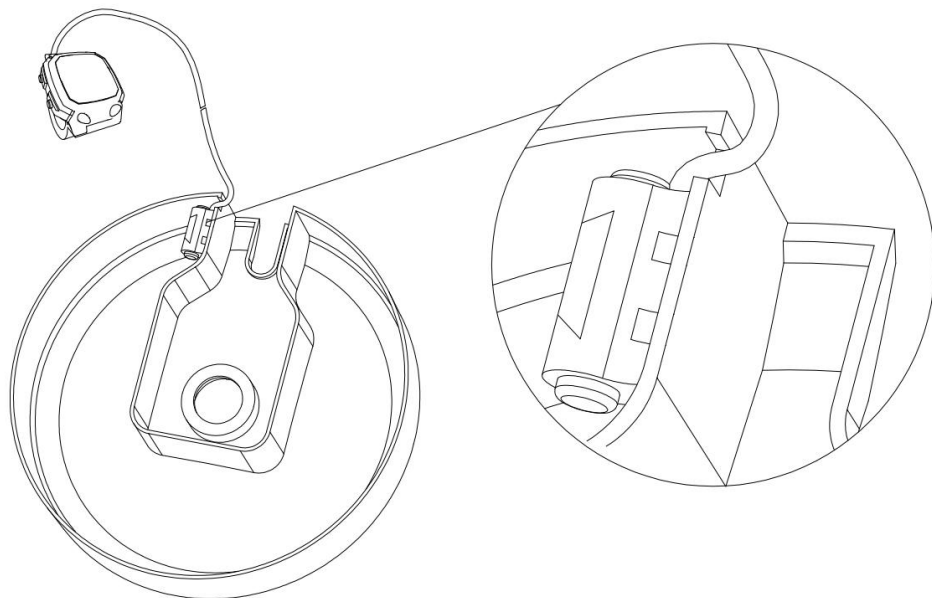

**PASO  
8**



T

X4

V

X4

R

X4

Q

X2

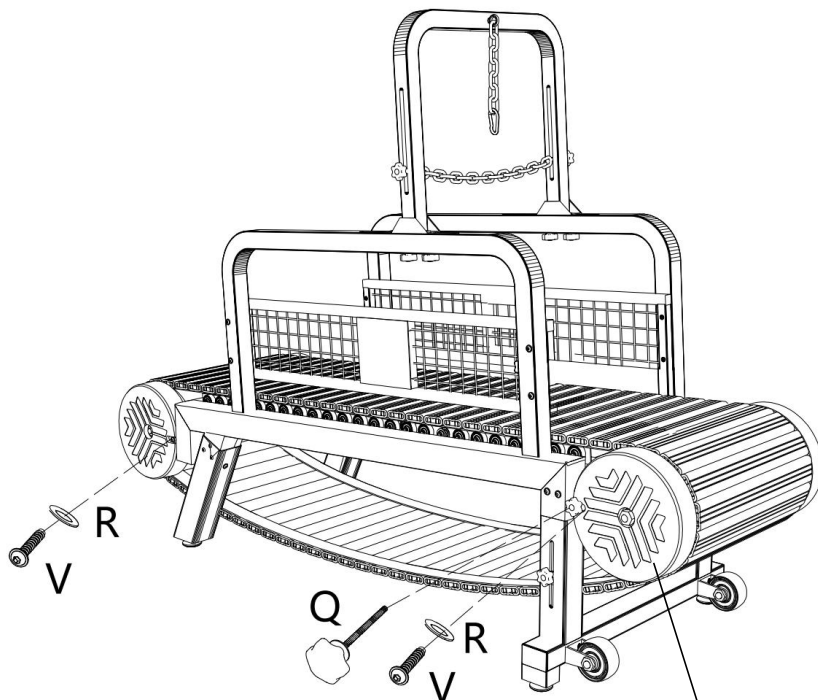

Instale el componente T (equipado con un sensor) del paso 7 anterior en esta posición.

La resistencia al correr de la cinta de correr se puede ajustar mediante el ajuste de tensión de la pieza Q.

**PASO**  
**9**



Q

X1

R

X1

U

X1

Instala el freno y fija el cuentakilómetros.

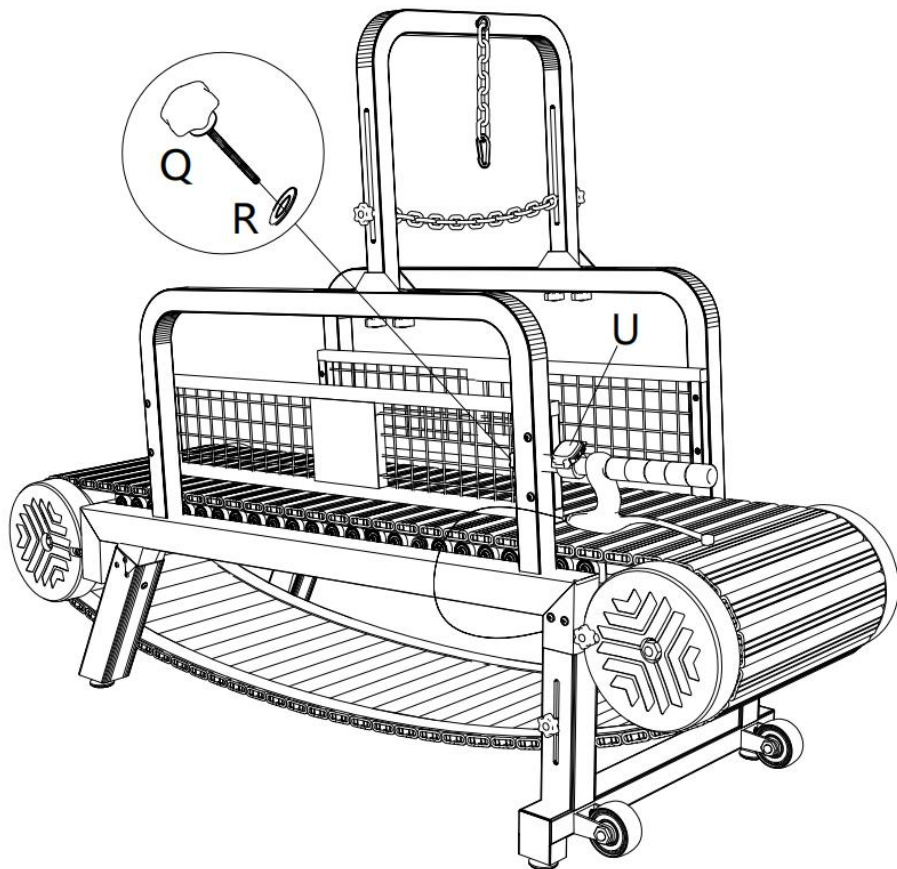

**Fabricante :** Shanghaimuxinmuyeyouxiangongsi

**Dirección:** Shuangchenglu 803nong11hao1602A700 x 450 x 12451609shi,  
baoshanqu, shanghai 200000 CN.

**Importado a Australia:** SIHAO PTY LTD. 1 ROKEVA STREET,  
EASTWOOD NSW 2122, Australia

**Importado a EE. UU.:** Sanven Technology Ltd. Suite 250, 9166 Anaheim  
Lugar: Rancho Cucamonga, CA 91730

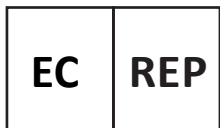

E-CrossStu GmbH

Mainzer Landstr.69, 60329 Frankfurt am Main.



YH CONSULTING LIMITED.

C/O YH Consulting Limited Office 147, Centurion House,  
London Road, Staines-upon-Thames, Surrey, TW18 4AX





# VEVOR

**Upgrade · The Home Creator Way**

Tapis roulant per cani

MODELLO: SSKL-3 SSKM-3

**MODELLO: SSKL-3 SSKM-3**

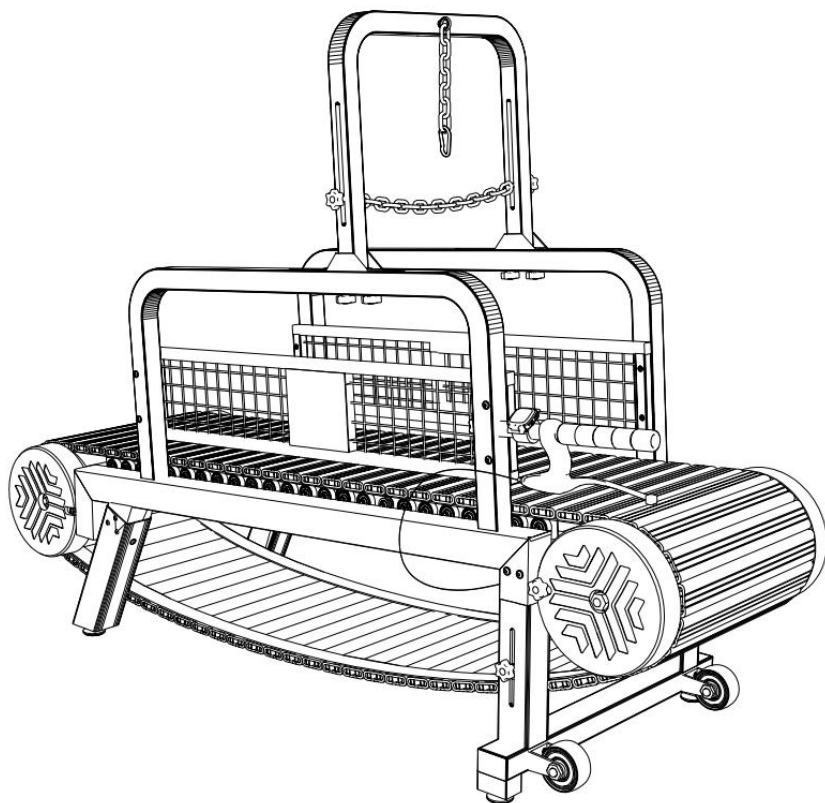

Queste sono le istruzioni originali, si prega di leggere attentamente tutte le istruzioni del manuale prima dell'uso. VEVOR si riserva la piena interpretazione del proprio manuale utente. L'aspetto del prodotto dipenderà dal prodotto ricevuto. Vi preghiamo di scusarci se non vi informeremo più in caso di aggiornamenti tecnologici o software sul nostro prodotto.

# Manuale di istruzioni del tapis roulant per cani

## Informazioni importanti sulla sicurezza:

- Leggi tutto istruzioni prima di utilizzare il tapis roulant.
- Non utilizzare il tapis roulant è malato se il tuo cane ha qualche problema di salute o ferisce che può essere aggravato dall'esercizio fisico.
- Sorvegliare sempre il cane quando utilizza il tapis roulant .
- Tenere i bambini e gli altri animali domestici lontani dal tapis roulant quando è in funzione utilizzo .
- Collega il tuo cane al tapis roulant io Il tramite l' imbracatura piuttosto che tramite un collare .
- Utilizzo IL tapis roulant insomma intervalli (non più di 20 minuti alla volta, con 10 minuti di corsa e 10 minuti di camminata separati) per evitare che il cane si surriscaldi o si esaurisca. Ridurre il tempo se il tuo il cane non è in ottime condizioni o si sente a disagio .

## Utilizzo del tapis roulant:

25. Permetti al tuo cane di esplorare la macchina e far sì che il tuo cane si abitui ad essa . Semplicemente facendolo sentire a suo agio in piedi o seduto su Esso.

26. Attacca il tuo cane al tapis roulant con l'imbracatura. Non fare mai affidamento su di loro per capire cosa per farlo ancora bisogna avere pazienza. Posizionarsi di fronte a loro e chiamare direttamente. Incoraggiateli a muovere le zampe lentamente. Non preoccupatevi se non lo fanno. Aspettate, lodateli .

27. Ripeti il passaggio n. 2 finché non potranno camminarci sopra da soli. Tenerli sempre in giro invece di all'inizio correre . Questo può aiutarli ad abituarsi completamente alla macchina . Dopo aver preso familiarità con la macchina, incoraggiateli a correre stando di fronte a loro e applaudendoli o chiamandoli a voi.

28. Una volta terminato l'utilizzo del tapis roulant pulire il tapis roulant.

## Manutenzione :

- Mantenere il tapis roulant pulito e privo di detriti.
- Regolarmente ispezionare la macchina per segni di usura o danno
- Lubrificare il tapis roulant come indicato dal produttore.
- Conservare il tapis roulant In UN luogo asciutto e sicuro quando non in uso.

## **FCC IN FORMAZIONE**

**ATTENZIONE:** Cambiamenti o modifiche non espressamente approvati dalla parte responsabile della conformità potrebbero invalidare l'autorizzazione dell'utente a utilizzare l'apparecchiatura!

Questo dispositivo è conforme alla Parte 15 delle Norme FCC. Il funzionamento è soggetto alle seguenti due condizioni:

- 1) Questo prodotto può causare interferenze dannose.
- 2) Questo prodotto deve accettare qualsiasi interferenza ricevuta, comprese quelle che potrebbero causare un funzionamento indesiderato.

**AVVERTIMENTO:** Eventuali modifiche o alterazioni apportate al prodotto non espressamente approvate dalla parte responsabile della conformità potrebbero invalidare l'autorizzazione dell'utente a utilizzare il prodotto.

**Nota:** Questo prodotto è stato testato e ritenuto conforme ai limiti previsti per i dispositivi digitali di Classe B, ai sensi della Parte 15 delle Norme FCC. Tali limiti sono concepiti per fornire una protezione ragionevole contro interferenze dannose in installazioni residenziali.

Questo prodotto genera, utilizza e può irradiare energia a radiofrequenza e, se non installato e utilizzato secondo le istruzioni, può causare interferenze dannose alle comunicazioni radio. Tuttavia, non vi è alcuna garanzia che tali interferenze non si verifichino in una particolare installazione. Se questo prodotto causa interferenze dannose alla ricezione radiofonica o televisiva, verificabili spegnendo e riaccendendo il prodotto, si consiglia all'utente di provare a correggere l'interferenza adottando una o più delle seguenti misure.

- Riorientare o riposizionare l'antenna ricevente.
- Aumentare la distanza tra il prodotto e il ricevitore.
- Collegare il prodotto a una presa di corrente su un circuito diverso da quello a cui è collegato il ricevitore.
- Per assistenza, consultare il rivenditore o un tecnico radio/TV esperto.



## WARNING!

**INGESTION HAZARD:** This product contains a button cell or coin battery.  
**DEATH** or serious injury can occur if ingested.  
A swallowed button cell or coin battery can cause internal **Chemical Burns** in as little as **2 hours**.  
KEEP new and used batteries **OUT OF REACH of CHILDREN**.  
**Seek immediate medical attention** if a battery is suspected to be swallowed or inserted inside any part of the body.



## WARNING!

**INGESTION HAZARD:** This product contains a button cell or coin battery.  
**DEATH** or serious injury can occur if ingested.  
A swallowed button cell or coin battery can cause internal **Chemical Burns** in as little as **2 hours**.  
KEEP new and used batteries **OUT OF REACH of CHILDREN**.  
**Seek immediate medical attention** if a battery is suspected to be swallowed or inserted inside any part of the body.











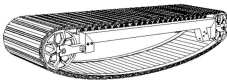
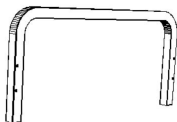
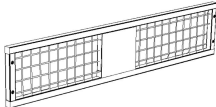
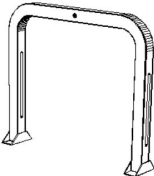
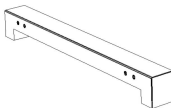

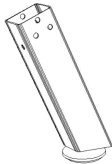
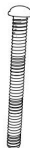
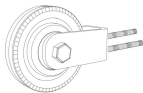

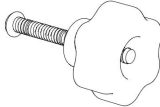
## SPECIFICHE

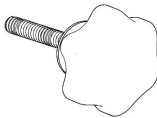
Modello	SSKL- 3
Dimensioni del prodotto	1910*570*1400mm
Colore	Nero

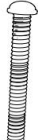





Modello	SSKM- 3
Dimensioni del prodotto	1750*510*1360mm
Colore	Nero





## ELENCO DEI PEZZI

			
Un x1	B x2	C x2	D x1
			
E x1	F x2	Sol x2	Altezza x2
			
M8*80mm J x4	K x2	L x1	M x1
			
N x4	P x2	Domanda x3	T x4
			
		M8*25 mm	

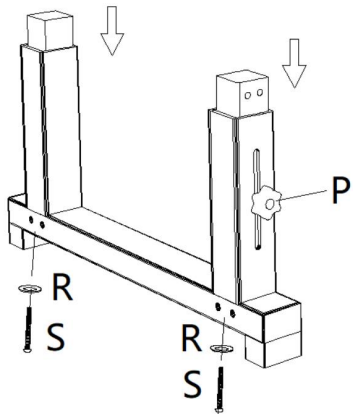
	M8*60mm	V x16	L x2
U x1	S x20	 R x50	 Y x1



## FASE DI MONTAGGIO S

<b>PASSO 1</b>										
	E	X1	F	X2	G	X2	P	X2	R	X2
	L'altezza del tapis roulant può essere regolata tramite la parte P									
S	X2									

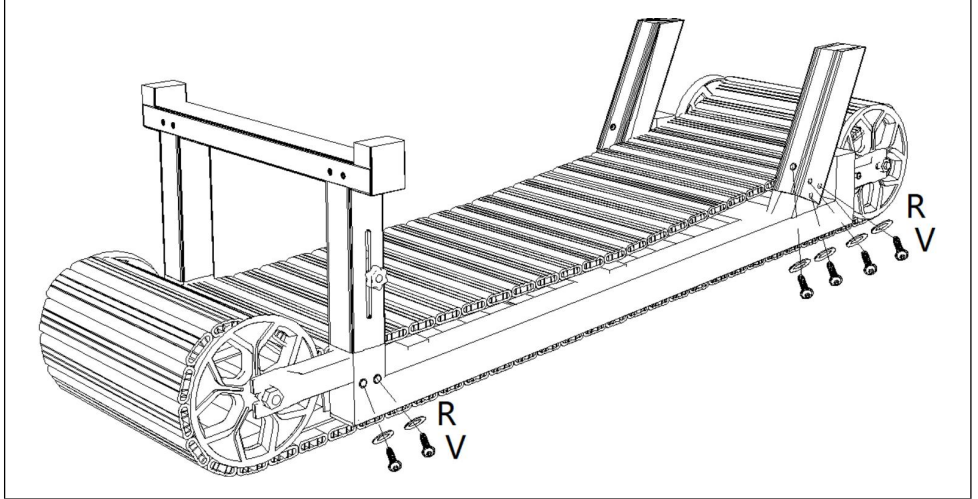
<b>PASS</b> <b>O 2</b>									
	<b>U</b> <b>N</b>	X1	H	X2	R	X12	V	X12	





**PASS  
O 3**

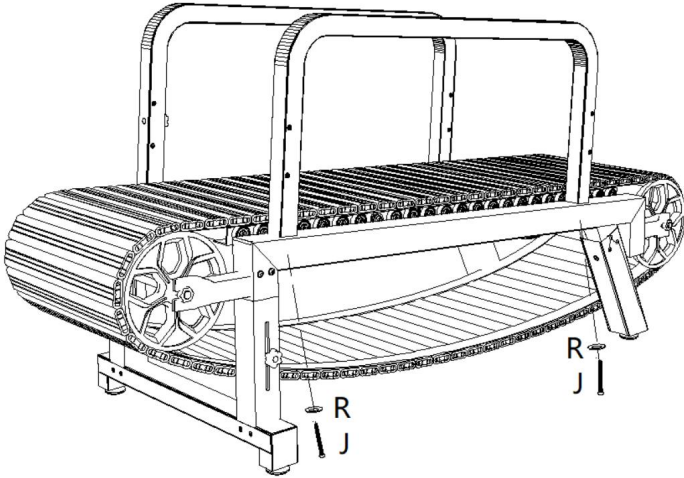

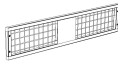

					
B	X2	R	X4	J	X4

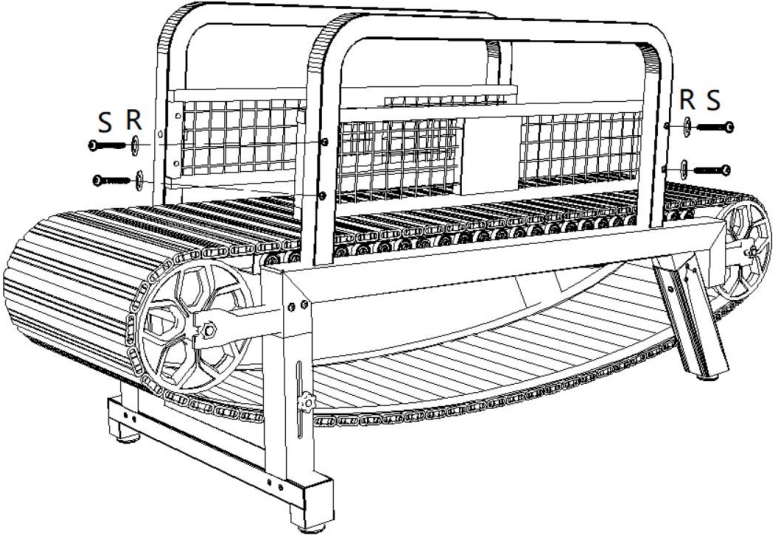

**PASS  
O 4**

					
C	X2	R	X8	S	X8



<b>PASS O 5</b>										
	D	X1	L	X1	M	X1	N	X4	R	X14

Il componente M può essere fissato in alto (posizione) o sul componente L.

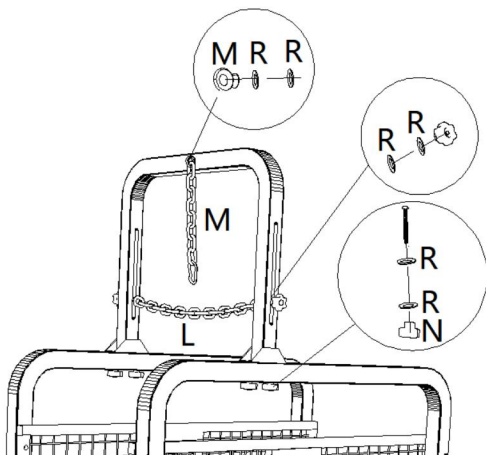

<b>PASS O 6</b>		
	K	X2

Rimuovere il dado dal componente K, farlo passare attraverso la staffa E e quindi serrare il dado.

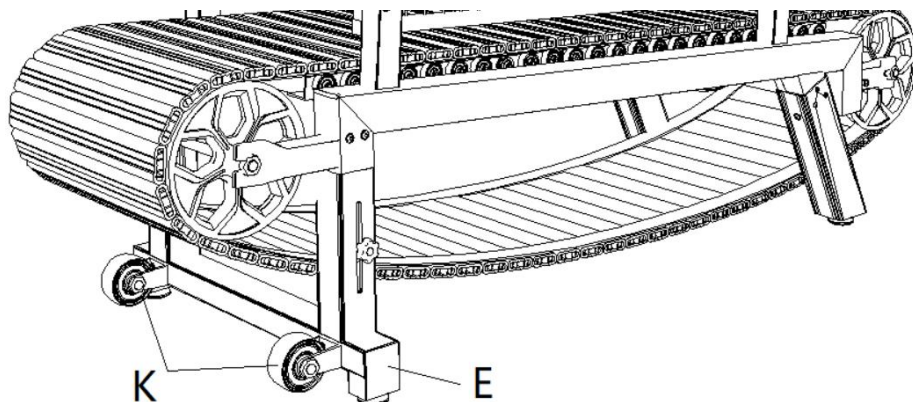

**PASS  
07**



T

X1

Tu

X1

Installare il sensore a filo con la posizione indicata nello schema. Far passare il filo in uscita attraverso la fessura e, durante l'installazione, assicurarsi che il filo non entri in contatto con la ruota in rotazione.

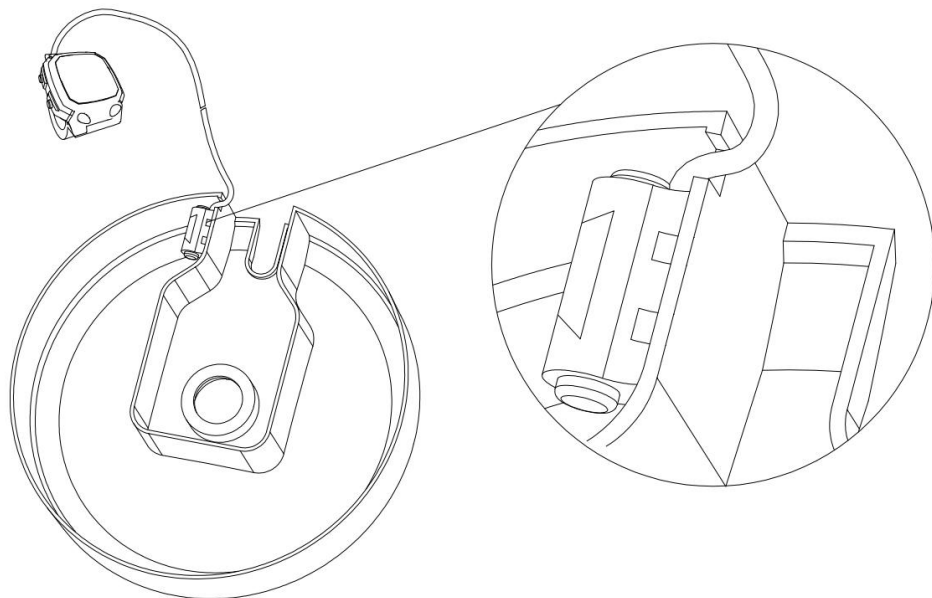

<b>PASS</b> <b>O 8</b>								
	T	X4	V	X4	R	X4	Q	X2

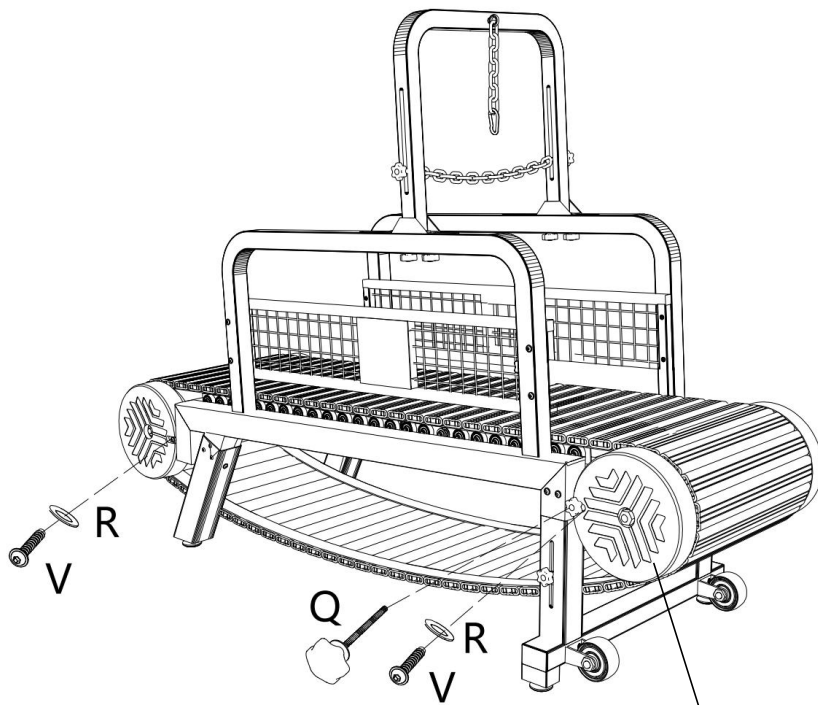

Installare il componente T (dotato di sensore) del precedente passaggio 7 in questa posizione.

La resistenza alla corsa del tapis roulant può essere regolata tramite la regolazione della tensione della parte Q.

**PASS  
09**



Q

X1

R

X1

Tu

X1

Installare il freno e fissare il contachilometri.

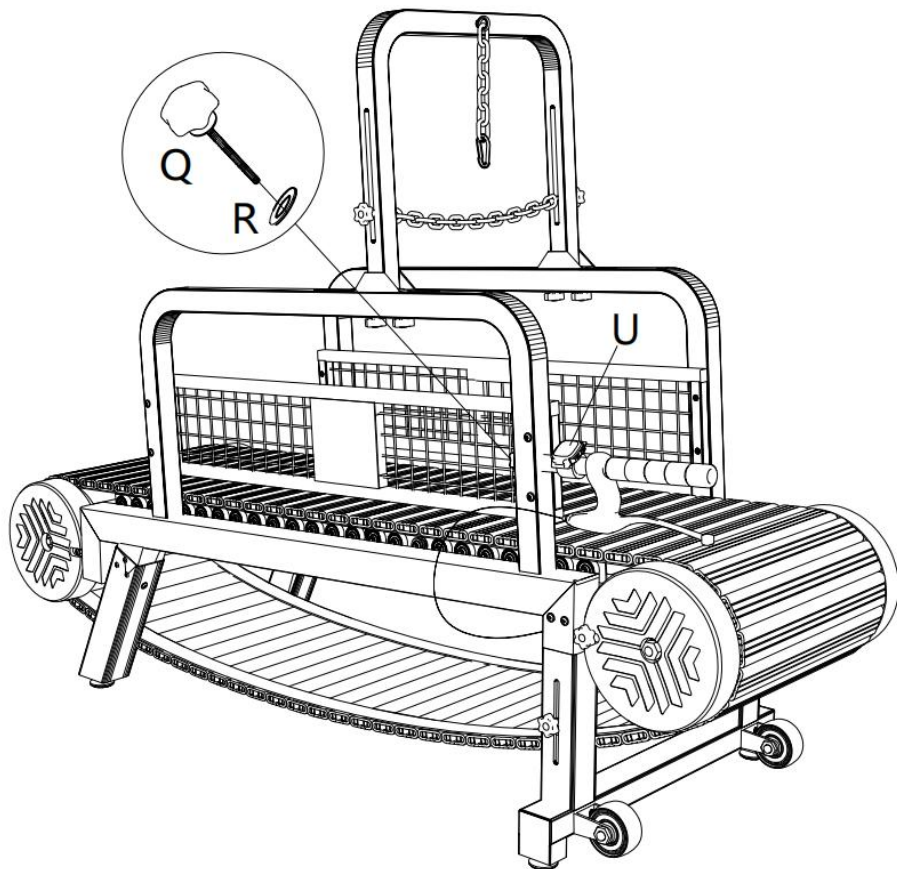

**Produttore** : Shanghaimuxinmuyeyouxiangongsi

**Indirizzo**: Shuangchenglu 803nong11hao1602A700 x 450 x 12451609shi,  
baoshanqu, shanghai 200000 CN.

**Importato in AUS**: SIHAO PTY LTD. 1 ROKEVA STREETEASTWOOD  
NSW 2122 Australia

**Importato negli USA**: Sanven Technology Ltd. Suite 250, 9166 Anaheim  
Luogo, Rancho Cucamonga, CA 91730

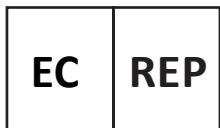

E-CrossStu GmbH

Mainzer Landstr.69, 60329 Frankfurt am Main.



YH CONSULTING LIMITED.

C/O YH Consulting Limited Office 147, Centurion House,  
London Road, Staines-upon-Thames, Surrey, TW18 4AX





# VEVOR

**Upgrade · The Home Creator Way**

Bieżnia dla psa

MODEL: SSKL-3 SSKM-3

**MODEL: SSKL-3 SSKM-3**

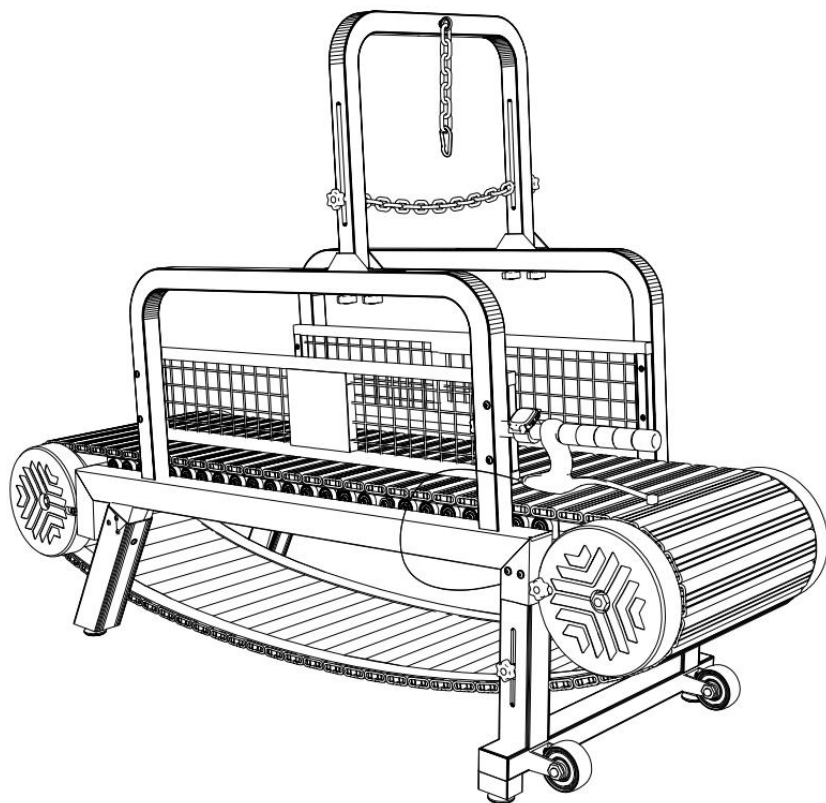

To jest oryginalna instrukcja obsługi. Przed użyciem prosimy o dokładne zapoznanie się z treścią instrukcji. Firma VEVOR zastrzega sobie prawo do jednoznacznej interpretacji niniejszej instrukcji obsługi. Wygląd produktu zależy od stanu, w jakim go otrzymali Państwo. Prosimy o wyrozumiałość, ale nie będziemy Państwa ponownie informować o aktualizacjach technologicznych lub

oprogramowania naszego produktu.

## **Instrukcja obsługi bieżni dla psa**

### **Ważne informacje dotyczące bezpieczeństwa:**

- Przeczytaj wszystkie instrukcje przed użyciem bieżni .
- Nie używać bieżni, jeśli Twój pies ma jakieś problemy zdrowotne lub rani, które mogą się nasilać podczas ćwiczeń.
- Zawsze nadzoruj swojego psa podczas korzystania z bieżni .
- Trzymaj dzieci i inne zwierzęta z dala od bieżni , gdy jest włączona. używać .
- Połącz swoje pies na bieżnię, ja będę za pomocą uprzęży , a nie kołnierza .
- Używać ten kierat krótko mówiąc przerwy (nie dłuższe niż 20 minut na raz, z 10 minutami biegu i 10 minutami marszu oddzielnymi), aby zapobiec przegrzaniu lub wyczerpaniu psa. Skróć czas, jeśli Twój Pies nie jest w najlepszym stanie lub czuje się niekomfortowo .

### **Korzystanie z bieżni:**

29. Pozwól swojemu psu Poznaj maszynę i pozwól psu się do niej przyzwycząć . Po prostu spraw, by czuł się komfortowo stojąc lub siedząc. To.

30. Przypnij psa do bieżni zakładając mu uprząż. Nigdy nie polegaj na nich, żeby dowiedzieć się, co jeszcze tylko uzbroj się w cierpliwość. Stań przed nimi i zadzwoń bezpośrednio do nich. Zachęcaj je do powolnego poruszania łapkami. Nie martw się, jeśli tego nie zrobią. Poczekaaj i pochwal je .

31. Powtórz krok nr 2 dopóki nie będą mogli po nim chodzić przez nich samych. Zawsze każ im chodzić zamiast Na początku nie uruchamiaj urządzenia . To może pomóc im całkowicie przyzwycząć się do maszyny. Po zapoznaniu się z maszyną , zachęcaj ich do biegania, stając przed nimi i bijąc im brawo lub wołając ich do siebie.

32. Po zakończeniu korzystania z bieżni posprzątaj bieżnię.

### **Konserwacja :**

- Trzymać bieżnia czysta i wolna od gruz.
- Regularnie sprawdź maszynę pod kątem oznak zużycia lub uszkodzenia szkoda
- Należy smarować bieżnię zgodnie z zaleceniami producenta.
- Przechowuj bieżnię W A suchym i bezpiecznym miejscu, gdy nieużywane.

## **FCC W FORMACJI**

**OSTROŻNOŚĆ:** Zmiany lub modyfikacje dokonane bez wyraźnej zgody strony odpowiedzialnej za zgodność mogą spowodować unieważnienie prawa użytkownika do korzystania ze sprzętu!

To urządzenie jest zgodne z częścią 15 przepisów FCC. Jego eksploatacja podlega dwóm następującym warunkom:

- 1) Ten produkt może powodować szkodliwe zakłócenia.
- 2) Produkt ten musi być odporny na wszelkie zakłócenia, w tym zakłócenia mogące powodować niepożądane działanie.

**OSTRZEŻENIE:** Zmiany lub modyfikacje tego produktu, które nie zostały wyraźnie zatwierdzone przez stronę odpowiedzialną za zgodność, mogą unieważnić prawo użytkownika do korzystania z produktu.

**Notatka:** Ten produkt został przetestowany i uznany za zgodny z ograniczeniami dla urządzeń cyfrowych klasy B, zgodnie z częścią 15 przepisów FCC. Ograniczenia te mają na celu zapewnienie odpowiedniej ochrony przed szkodliwymi zakłóceniami w instalacjach domowych.

Ten produkt generuje, wykorzystuje i może emitować energię o częstotliwości radiowej i jeśli nie zostanie zainstalowany i używany zgodnie z instrukcją, może powodować szkodliwe zakłócenia w komunikacji radiowej. Nie ma jednak gwarancji, że zakłócenia nie wystąpią w danej instalacji. Jeśli ten produkt powoduje szkodliwe zakłócenia w odbiorze sygnału radiowego lub telewizyjnego, co można sprawdzić, wyłączając i włączając urządzenie, zaleca się, aby użytkownik spróbował skorygować zakłócenia, stosując jeden lub kilka z poniższych środków.

- Zmiana orientacji lub położenia anteny odbiorczej.
- Zwiększ odległość między produktem i odbiornikiem.
- Podłączyć produkt do gniazdka w innym obwodzie niż ten, do którego podłączony jest odbiornik.
- Aby uzyskać pomoc, skontaktuj się ze sprzedawcą lub doświadczonym technikiem radiowo-telewizyjnym.



## WARNING!

**INGESTION HAZARD:** This product contains a button cell or coin battery.  
**DEATH** or serious injury can occur if ingested.  
A swallowed button cell or coin battery can cause internal **Chemical Burns** in as little as **2 hours**.  
KEEP new and used batteries **OUT OF REACH of CHILDREN**.  
**Seek immediate medical attention** if a battery is suspected to be swallowed or inserted inside any part of the body.



## WARNING!

**INGESTION HAZARD:** This product contains a button cell or coin battery.  
**DEATH** or serious injury can occur if ingested.  
A swallowed button cell or coin battery can cause internal **Chemical Burns** in as little as **2 hours**.  
KEEP new and used batteries **OUT OF REACH of CHILDREN**.  
**Seek immediate medical attention** if a battery is suspected to be swallowed or inserted inside any part of the body.











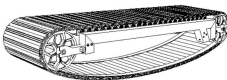

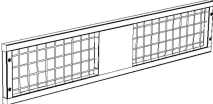
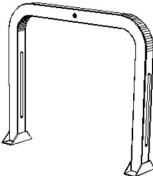
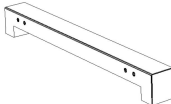

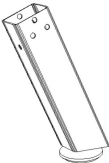
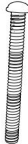
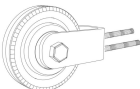

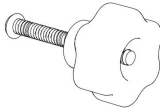
## SPECYFIKACJE

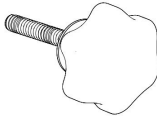
Model	SSKL- 3
Rozmiar produktu	1910*570*1400 mm
Kolor	Czarny

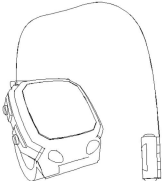

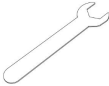

Model	SSKM- 3
Rozmiar produktu	1750*510*1360mm
Kolor	Czarny

# LISTA CZĘŚCI

			
A x1	B x2	C x2	D x1
			
E x1	F x2	G x2	Wysokość x2
			
M8*80mm J x4	K x2	Długość x1	M x1
			
N x4	P x2	Q x3	T x4
			
		M8*25 mm V x16	Szerokość x2

	M8*60mm		
U x1	S x20	R x50	Y x1

## S MONTAŻU

<b>KROK 1</b>					
	m i	X1	F X2	G X2	P X2



Wysokość bieżni można regulować za pomocą części P

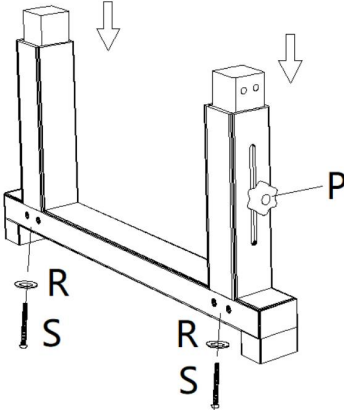

S	X2
---	----

**KROK  
2**



A

X1

H

X2

R

X12

V

X12

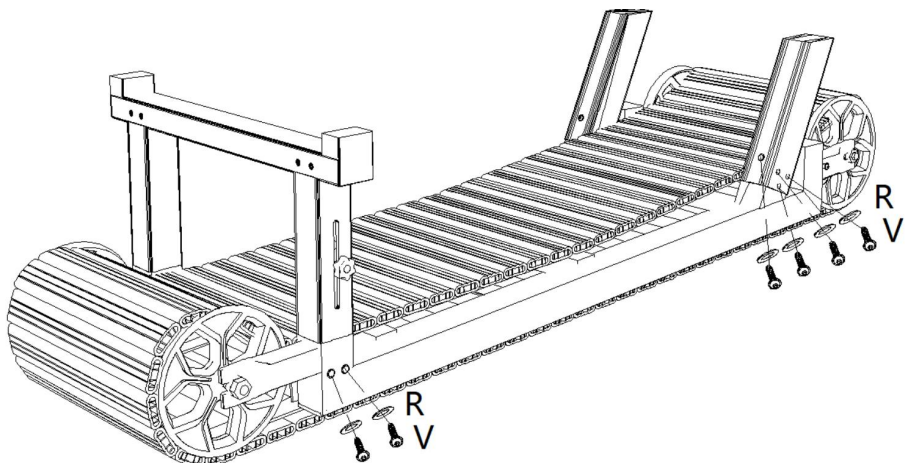

**KROK  
3**



B

X2



R

X4



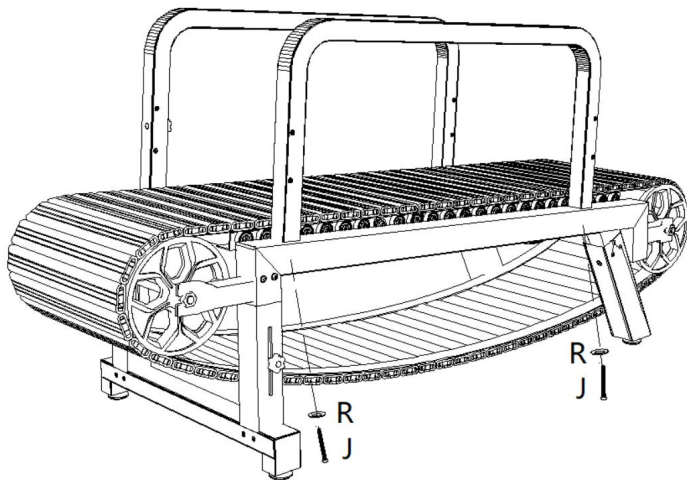

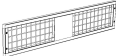
J

X4

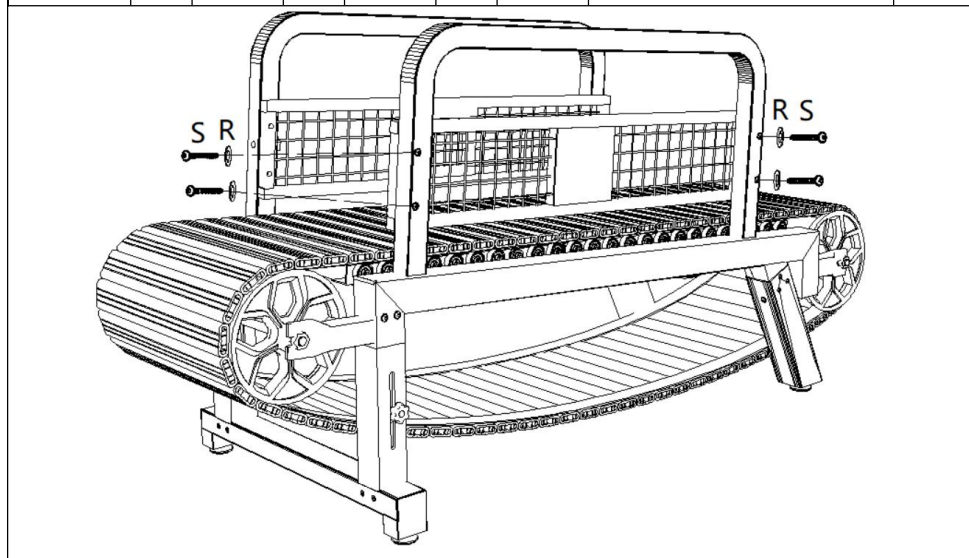

<b>KROK 4</b>								
	C	X2	R	X8	S	X8		



<b>KROK 5</b>										
	D	X1	L	X1	M	X1	N	X4	R	X14

Komponent M może być zamocowany na górze (pozycja) lub na komponente L.

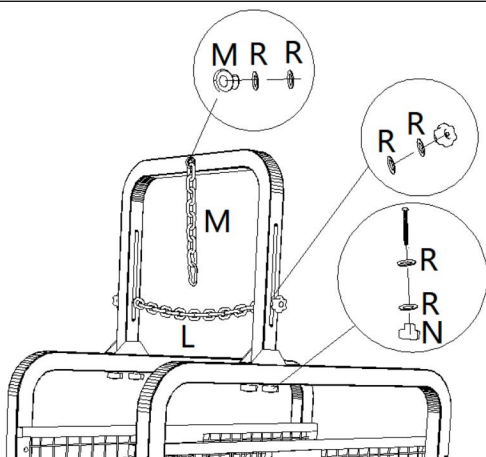

**KROK  
6**

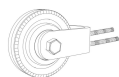

K X2

Odkręć nakrętkę od elementu K, przełóż ją przez wspornik E, a następnie dokręć nakrętkę.

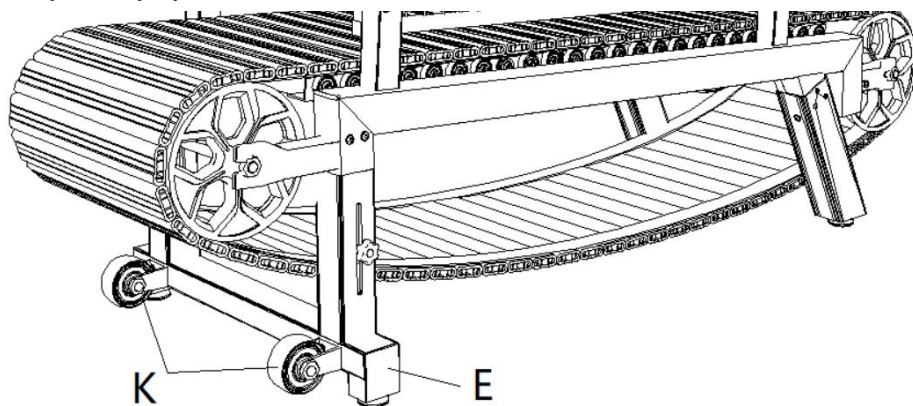

**KROK  
7**



T

X1

U

X1

Zamontuj czujnik w miejscu pokazanym na schemacie. Przeprowadź przewód wychodzący przez szczelinę i podczas montażu upewnij się, że przewód nie styka się z obracającym się kołem.

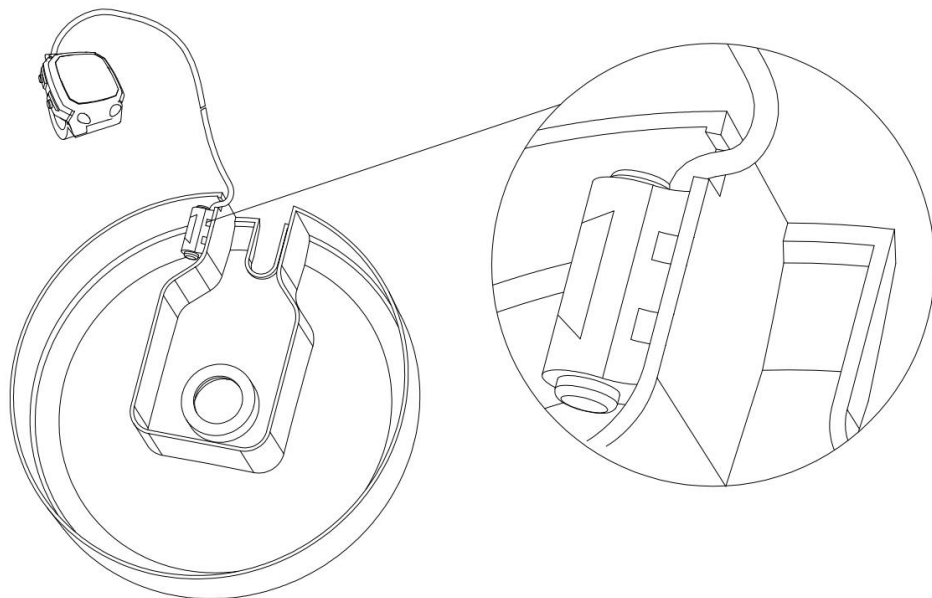

**KROK  
8**



T

X4

V

X4

R

X4

Q

X2

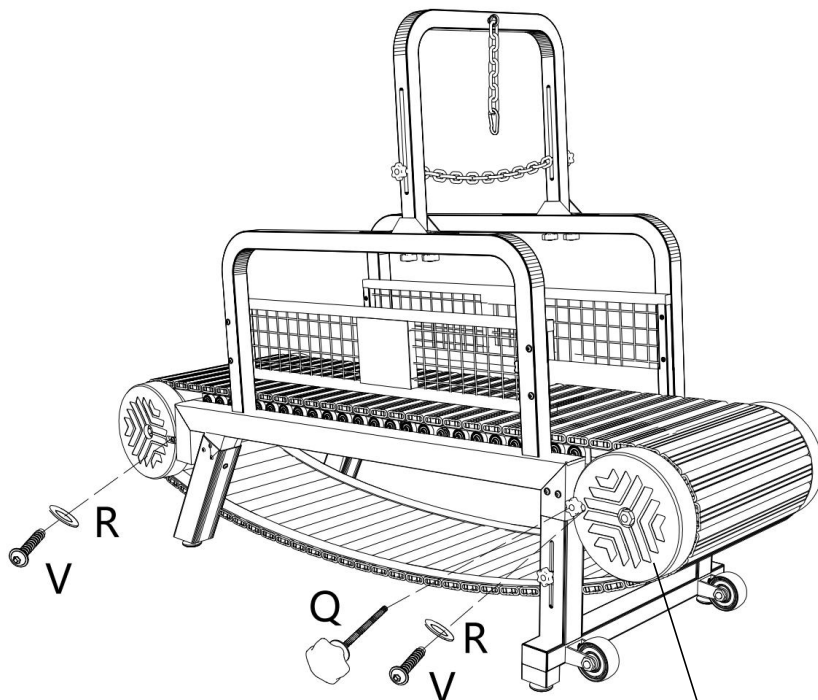

Zainstaluj w tym miejscu komponent T (wyposażony w czujnik) z poprzedniego kroku 7.

Opór bieżni można regulować poprzez regulację napięcia części Q.

**KROK  
9**



Q

X1

R

X1

U

X1

Zamontuj hamulec i zabezpiecz licznik kilometrów.

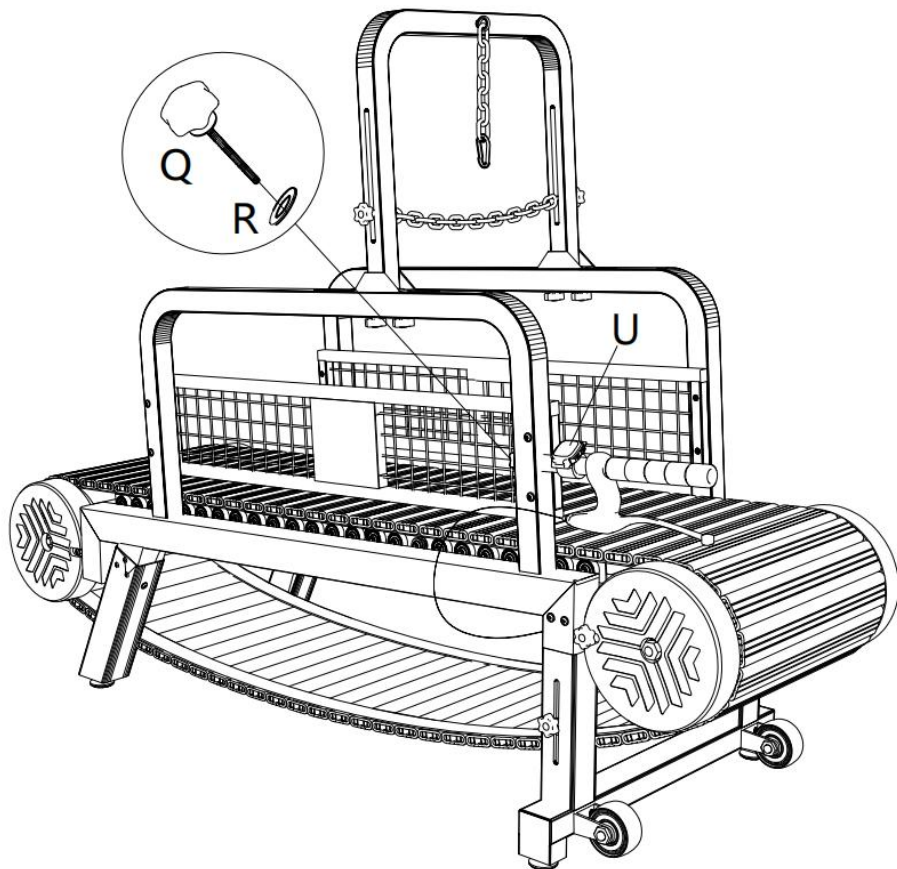

**Producent** : Shanghaimuxinmuyeyouxiangongsi

**Adres**: Shuangchenglu 803nong11hao1602A700 x 450 x 12451609shi,  
baoshanqu, szanghaj 200000 CN.

**Importowane do Australii**: SIHAO PTY LTD. 1 ROKEVA  
STREETEASTWOOD NSW 2122 Australia

**Importowane do USA**: Sanven Technology Ltd. Suite 250, 9166 Anaheim  
Miejsce, Rancho Cucamonga, CA 91730

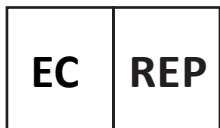

E-CrossStu GmbH

Mainzer Landstr.69, 60329 Frankfurt am Main.



YH CONSULTING LIMITED.

C/O YH Consulting Limited Office 147, Centurion House,  
London Road, Staines-upon-Thames, Surrey, TW18 4AX



