

VEVOR

Affordable. Reliable. Home Improvement.

MULTIPLE SHOWER HEADS

MODEL: FS10282-BN, FS10282-BN-G, FS10282-MB, FS10282-MB-G,
FS10281-CP, FS10281-CP-G, FS10281-BG, FS10281-BG-G,
FS10281-MB, FS10281-MB-G,
FS10280-BN, FS10280-BN-G, FS10280-MB, FS10280-MB-G,
FS10283-CP, FS10283-CP-G

VEVOR

Affordable. Reliable. Home Improvement.

MULTIPLE SHOWER HEADS

FS10280-BN, FS10280-BN-G
FS10280-MB, FS10280-MB-G

FS10281-CP, FS10281-CP-G
FS10281-BG, FS10281-BG-G
FS10281-MB, FS10281-MB-G

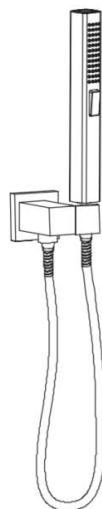
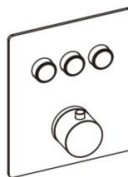
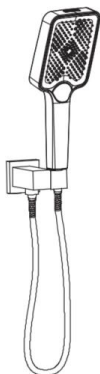
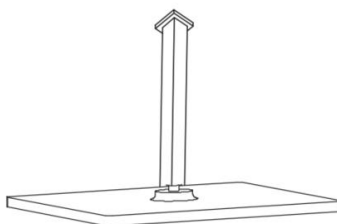
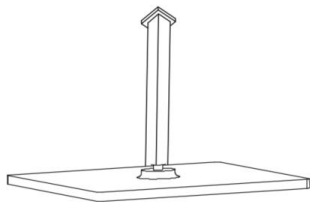

**FS10282-BN, FS10282-BN-G
FS10282-MB, FS10282-MB-G**

FS10283-CP, FS10283-CP-G

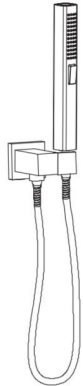
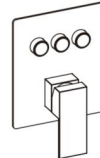
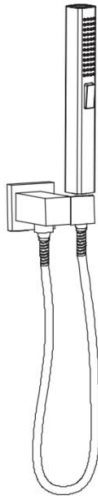
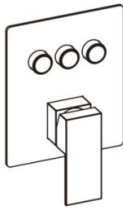
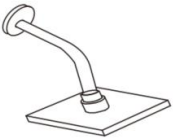
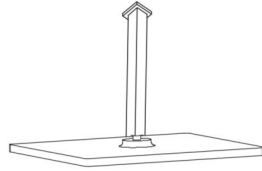
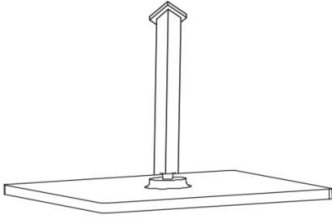

This is the original instruction, please read all manual instructions carefully before operating. VEVOR reserves a clear interpretation of our user manual. The appearance of the product shall be subject to the product you received. Please forgive us that we won't inform you again if there are any technology or software updates on our product.



Warning-To reduce the risk of injury, user must read instructions manual carefully.

INSTRUCTIONS

Warning Tips:

1. During the installation process, it is best to wear gloves to prevent sharp corners on the panel from scratching the palm of the hand.
2. When installing the shower, ensure that all joints are fully tightened to avoid water leakage.
3. When the shower is not in use, please close the switch valve of the shower.
4. Not be liable for any of the following claims : 1. Damage and/or breakdown caused by improper use and/or maintenance; Or any unauthorized Rebuild; including any damage caused by abuse (e.g. falls, drops, etc.) 2. Hire a professional plumber. Not responsible for any damage and/or failure caused by incorrect installation. 3. Damage and/or failure caused by removal after installation or other factors.
5. Damage and/or failure caused by applications beyond the scope of use.
6. Damage and/or failure caused by sand, dust and other impurities
7. Damage and/or failure caused by improper / inadequate maintenance; Rust surface treatment, etc.
8. Damage and/or failure caused by fire, earthquake, flood, lightning and other natural disasters, pollution, harmful gas, salt, abnormal voltage, and other factors.

Installation precautions.

1. Before installing the spool, clean the dirty water, residue, sand, and impurities remaining in the pipe before installing the spool. Do not open the protective cover before installing the spool to avoid impurities
2. Faucets and hot and cold water pipes must be installed correctly. Facing the faucet, connect hot water on the left and cold water on the right
3. Check the installation size. Do not forcibly install the product to avoid damaging the parts. How to Clean a shower head: In order to maintain the external brightness and good performance of the shower, please care for the shower in the following ways:
 - a. Rinse with water only and dry with a soft cotton cloth.
 - b. Place the shower head in a pot and fill the pot with enough white vinegar to cover the shower head. The acid in the vinegar helps dissolve the deposits on the

white mineral nozzle. Let the shower head soak in vinegar for 30 minutes. The dirtier the shower head, the longer you'll need to soak it in vinegar.

c. Mild liquid and colorless glass cleaner can be used to remove surface dirt and dirt film, not abrasive polish agent 4. Do not use acid detergent, insoluble granular detergent, soap, etc.

SAVE THESE INSTRUCTIONS

INSTALLATION INSTRUCTIONS

Model	FS10280	FS10281	FS10282	FS10283
Control Valve	Common Temperature	Constant Temperature	Common Temperature	Common Temperature
Head's Shower	12 Inch	12 Inch	10 Inch	10 Inch
Head's Shower	Square	Strip	Strip	Strip
Arm's Shower	6 Inch	6 Inch	6 Inch	Null
Back's Shower	Null	Null	Null	2 Inch
Flow Rate Description	2.2 GPM (8.3L/min)			
Pipe Threads	Null=NPT1/2"		-G=G1/2"	
Color	-BN=Brushed Nickel, -MB=Matte Black, -BG=Brushed Gold, -CP=Chrome Plating,			

PARTS LIST

Tools you may need



Wrench

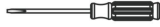





Screwdriver



Teflon Tape

Install Accessories

Hexagon Wrench (1pcs)	Teflon Tape (1pcs)	Screws (4pcs)	Bolt (4pcs)	Flat (4pcs)
				

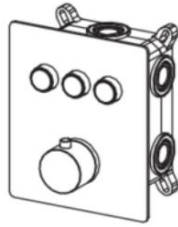

FS10281

Parts included

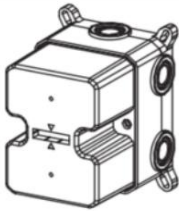

① Faucet Body

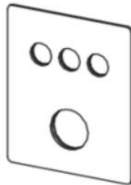

② Panel



③ Showerhead



④ Shower arm



⑤ Showerhead

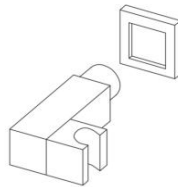

⑥ Shower Socket



⑦ Shower Hose

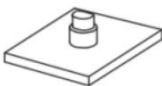

⑧ Showerhead

+



⑨ Shower arm

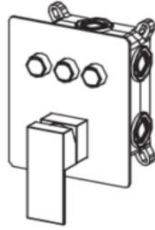

FS10280
FS10282
FS10283

Parts included

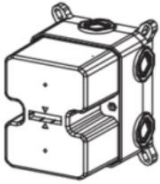

① Faucet Body

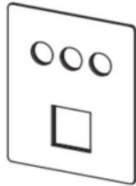

② Panel



③ Handle



④ Showerhead



⑤ Shower arm

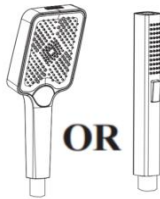

OR



⑥ Showerhead

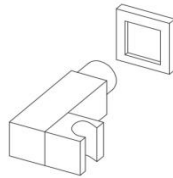

⑦ Shower Socket



⑧ Shower Hose

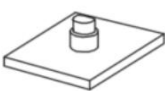

⑨ Showerhead

+

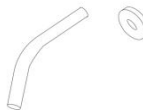

⑩ Shower arm

OR

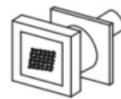

⑨ Back Spray*6

INSTALLATION STEPS

Suggest Installation Dimension

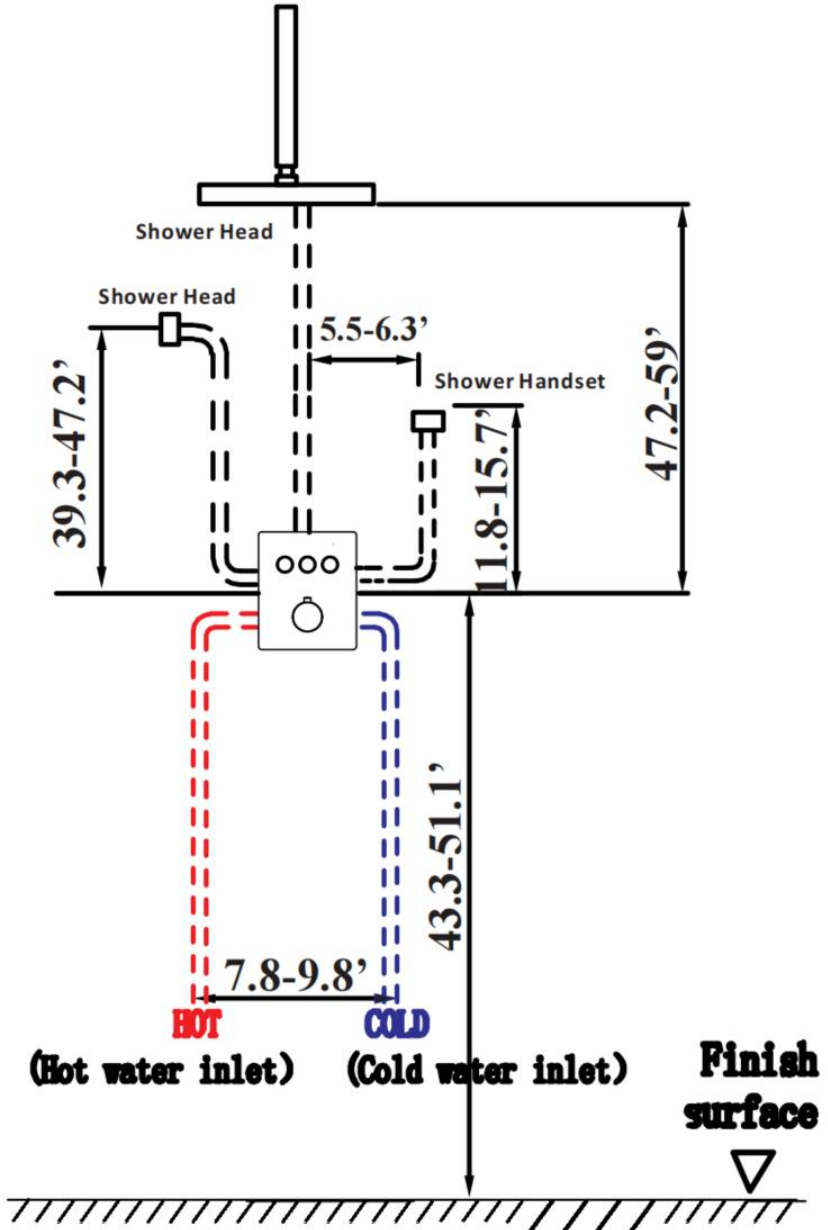

1. According to the site conditions and the installation size requirement and to make a hole,the hole size is 7in (length)* 5.5in (width) *2.75-3.15in (deep)

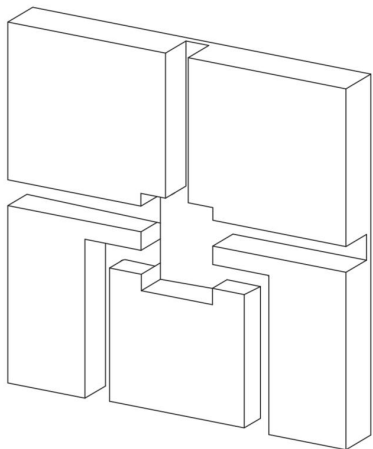

2. According to the site conditions and the installation size requirement to set up the pipe line. (2). Connect the plastic box to the pipe, put the plastic box on the hole, then adjust the levels(the bubble in the middle of the leveller).(3). Make the positioning holes.

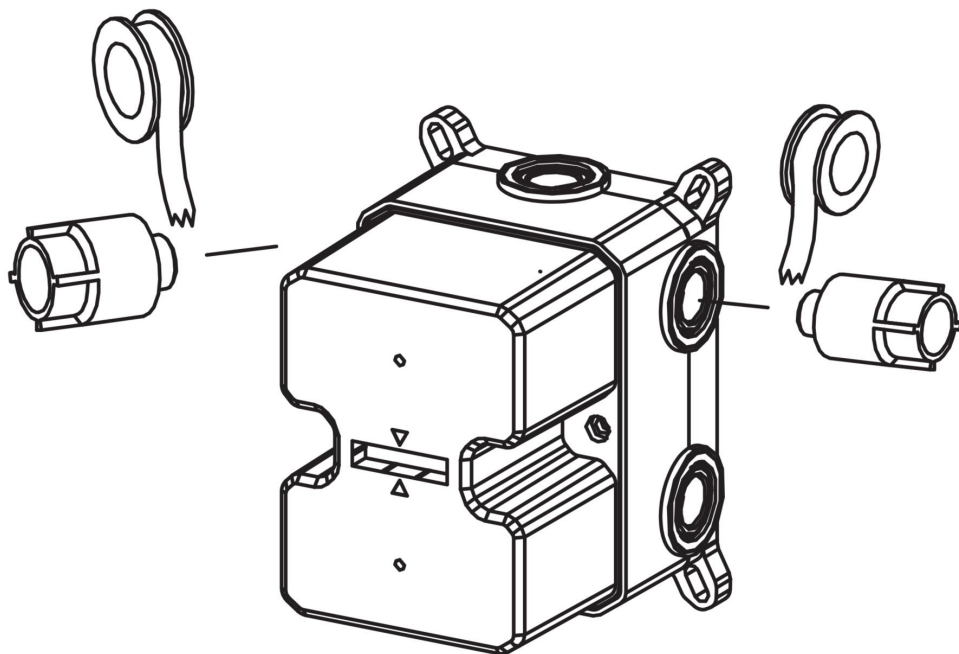

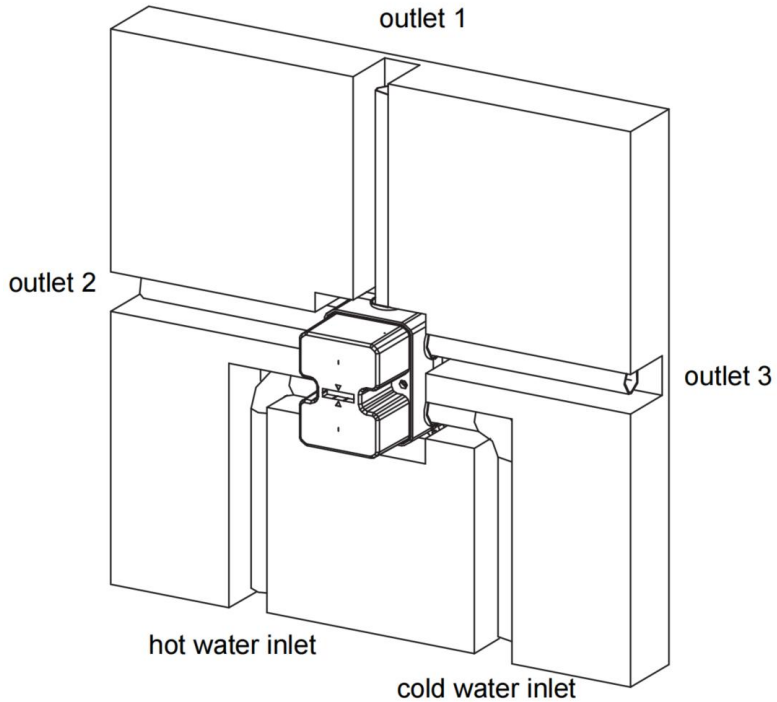

3. Remove the protective cover when the finished wall is completed and install the escutcheon (B) to the valve (A) and press it against the finished wall. Then, install the handle (C), tighten set screws (E) with Allen key (F), and put on the indication buttons (G).

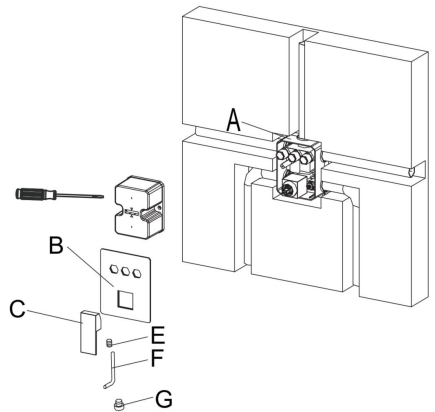
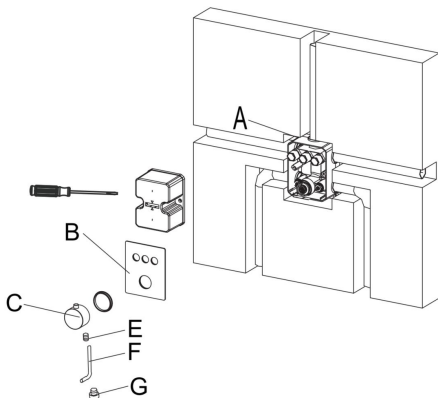

4. Turn the water on for 1 minute to flush any debris. Apply Teflon tape (H) to the threaded tail pipe and install the shower hose (I) into the outlet on the wall. Then connect the top shower (P) to the spout.

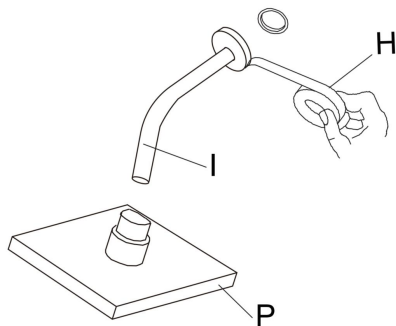
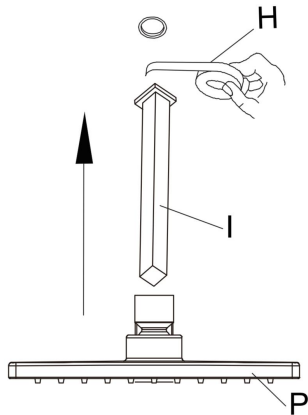

5. Apply Teflon tape (H) to the threaded end, then fix the cover plate (d) onto the wall supply holder (K) and screw the wall supply holder (K) into the hand shower outlet. and screw (E) with Allen key (F).

6. The distance between the bottom of the opening and the surface of the tile is 30mm. Twist the nozzle to the pipe embedded in the wall;

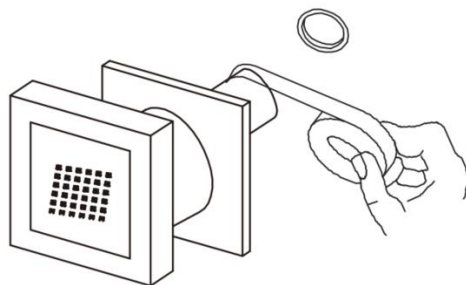
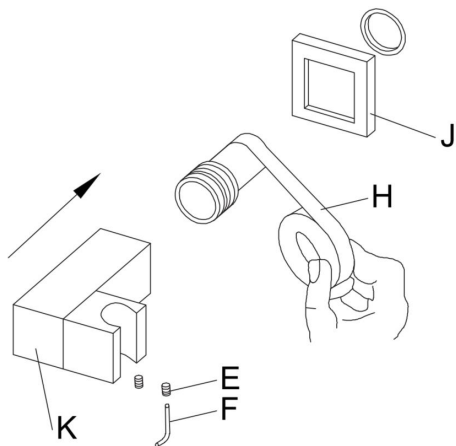

Product usage

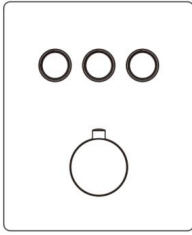

Key switch

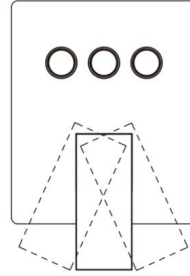

Key switch

Rotating temperature control

Rotating temperature control

CLEANING

1. To maintain proper working conditions or cleaning is required when mineral deposits appear on spray nozzles. To clean mineral deposits or gently rub rubber nozzles on the face of shower head to dislodge.
2. To clean heavier deposits/remove shower head and soak face down in a cup of white vinegar for 2-3 hours. Replace shower head and run in each spray setting to flush out vinegar, DO NOT use harsh chemicals/heavy-duty cleaners or abrasives. This may damage parts or finished product and may void warranty.

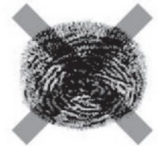

Manufacturer: Shanghaimuxinmuyeyouxiangongsi

Address: Shuangchenglu 803nong11hao1602A-1609shi, baoshanqu, shanghai 200000 CN.

Imported to AUS: SIHAO PTY LTD. 1 ROKEVA STREETEASTWOOD NSW 2122 Australia

Imported to USA: Sanven Technology Ltd. Suite 250, 9166 Anaheim Place, Rancho Cucamonga, CA 91730

UK	REP
-----------	------------

YH CONSULTING LIMITED. C/O YH Consulting Limited Office 147, Centurion House, London Road, Staines-upon-Thames, Surrey, TW18 4AX

EC	REP
-----------	------------

E-CrossStu GmbH
Mainzer Landstr.69,
60329 Frankfurt am Main.



VEVOR

Affordable. Reliable. Home Improvement.

POMMES DE DOUCHE MULTIPLES

MODÈLE: FS10282-BN, FS10282-BN-G, FS10282-MB, FS10282-MB-G,
FS10281-CP, FS10281-CP-G, FS10281-BG, FS10281-BG-G,
FS10281-MB, FS10281-MB-G ,
FS10280-BN, FS10280-BN-G, FS10280-MB, FS10280-MB-G,
FS10283-CP, FS10283-CP-G

VEVOR

Affordable. Reliable. Home Improvement.

MULTIPLE SHOWER HEADS

FS10280-BN , FS10280-BN-G
FS10280-MB , FS10280-MB-G

FS10281-CP , FS10281-CP-G
FS10281-BG , FS10281-BG-G
FS10281-MB , FS10281-MB-G

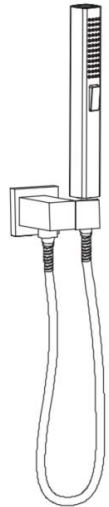
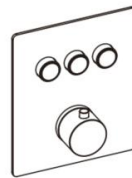
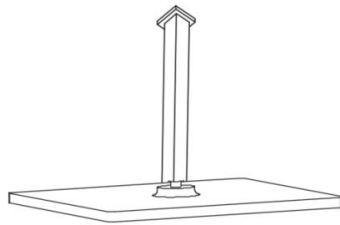
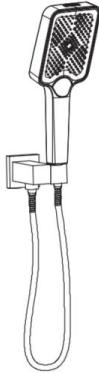
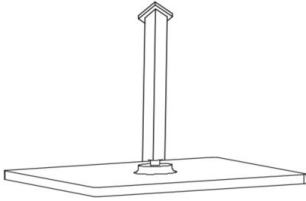

**FS10282-BN, FS10282-BN-G
FS10282-MB, FS10282-MB-G**

FS10283-CP, FS10283-CP-G

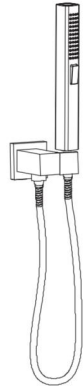
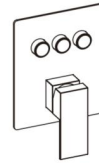
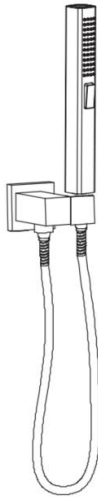
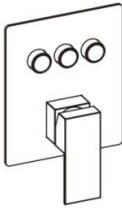
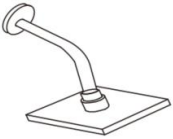
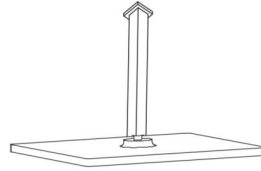
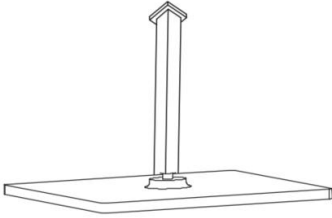

Ceci est le mode d'emploi d'origine. Veuillez lire attentivement l'intégralité du manuel avant utilisation. VEVOR se réserve le droit d'interpréter clairement ce manuel d'utilisation. L'apparence du produit dépend du produit que vous avez reçu. Veuillez nous excuser pour les éventuelles mises à jour technologiques ou logicielles.



Avertissement - Pour réduire le risque de blessure, l'utilisateur doit lire attentivement le manuel d'instructions.

INSTRUCTIONS

Conseils d'avertissement :

9. Pendant le processus d'installation, il est préférable de porter des gants pour éviter que les coins pointus du panneau ne rayent la paume de la main.
10. Lors de l'installation de la douche, assurez-vous que tous les joints sont bien serrés pour éviter les fuites d'eau.
11. Lorsque la douche n'est pas utilisée, veuillez fermer la vanne de commutation de la douche.
12. Ne sera pas responsable de l'une des réclamations suivantes : 1. Dommages et/ou pannes causés par une utilisation et/ou un entretien inappropriés ; ou toute reconstruction non autorisée ; y compris tout dommage causé par un abus (par exemple chutes, gouttes, etc.) 2. Faites appel à un plombier professionnel. Nous déclinons toute responsabilité en cas de dommages ou de pannes causés par une installation incorrecte. 3. Dommages et/ou défaillances causés par le retrait après l'installation ou par d'autres facteurs.
13. Dommages et/ou pannes causés par des applications dépassant le cadre d'utilisation.
14. Dommages et/ou pannes causés par le sable, la poussière et d'autres impuretés
15. Dommages et/ou pannes causés par un entretien inapproprié/inadéquat ; Traitement de surface antirouille, etc.
16. Dommages et/ou pannes causés par un incendie, un tremblement de terre, une inondation, la foudre et d'autres catastrophes naturelles, la pollution, les gaz nocifs, le sel, une tension anormale et d'autres facteurs.

Précautions d'installation.

1. Avant d'installer la bobine, nettoyez le tuyau de l'eau sale, des résidus, du sable et des impuretés. N'ouvrez pas le couvercle de protection avant d'installer la bobine afin d'éviter les impuretés.
2. Les robinets et les conduites d'eau chaude et froide doivent être correctement installés. Face au robinet, raccordez l'eau chaude à gauche et l'eau froide à droite.
3. Vérifiez les dimensions de l'installation. Ne forcez pas pour éviter d'endommager les pièces. Comment nettoyer un pommeau de douche : Pour

préserver la luminosité extérieure et le bon fonctionnement de votre douche, veuillez suivre les conseils suivants :

- d. Rincer à l'eau uniquement et sécher avec un chiffon doux en coton.
- e. Placez le pommeau de douche dans un récipient et remplissez-le de vinaigre blanc pour le recouvrir. L'acidité du vinaigre dissout les dépôts sur la buse minérale blanche. Laissez tremper le pommeau dans le vinaigre pendant 30 minutes. Plus le pommeau est sale, plus le temps de trempage sera long.
- f. Un nettoyeur pour vitres liquide doux et incolore peut être utilisé pour éliminer la saleté de surface et le film de saleté, et non un agent de polissage abrasif. 4. N'utilisez pas de détergent acide, de détergent granulaire insoluble, de savon, etc.

CONSERVEZ CES INSTRUCTIONS

INSTALLATION INSTRUCTIONS

Modèle	FS10280	FS10281	FS10282	FS10283
vanne de régulation	Température commune	Température constante	Température commune	Température commune
Tête Douche	12 pouces	12 pouces	10 pouces	10 pouces
Tête Douche	Carré	Bande	Bande	Bande
Douche à bras	6 pouces	6 pouces	6 pouces	Nul
Douche du dos	Nul	Nul	Nul	2 pouces
Description du débit	2,2 GPM (8,3 L / min)			
Filetages de tuyaux	Nul = NPT1/2" -G = G1/2"			
Couleur	-B N=Nickel brossé, -M B= Noir mat , -B G=Or brossé, -C P=Chrome,			

PARTS LIST

Outils dont vous pourriez avoir besoin



Wrench

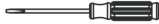





Screwdriver



Teflon Tape

Installer des accessoires

Clé hexagonale (1 pièce)	Ruban Téflon (1 pièce)	Vis (4 pièces)	Boulon (4 pièces)	Plat (4 pièces)
				

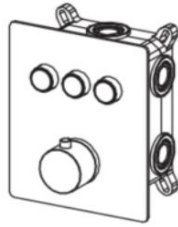

FS10281

Parts included

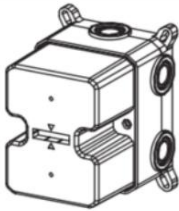

① Faucet Body

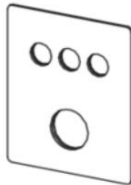

② Panel



③ Showerhead



④ Shower arm



⑤ Showerhead

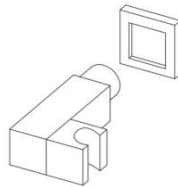

⑥ Shower Socket



⑦ Shower Hose

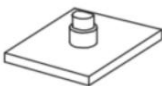

⑧ Showerhead

+



⑨ Shower arm

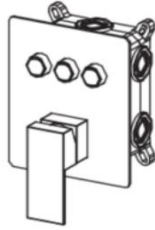

FS10280
FS10282
FS10283

Parts included

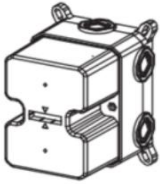

① Faucet Body

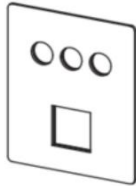

② Panel



③ Handle



④ Showerhead



⑤ Shower arm

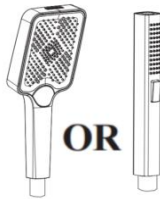

OR



⑥ Showerhead

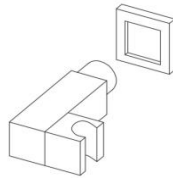

⑦ Shower Socket



⑧ Shower Hose

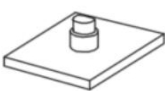

⑨ Showerhead

+

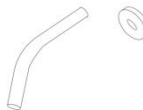

⑩ Shower arm

OR

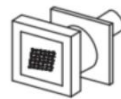

⑨ Back Spray*6

INSTALLATION STEPS

Suggérer des dimensions d'installation

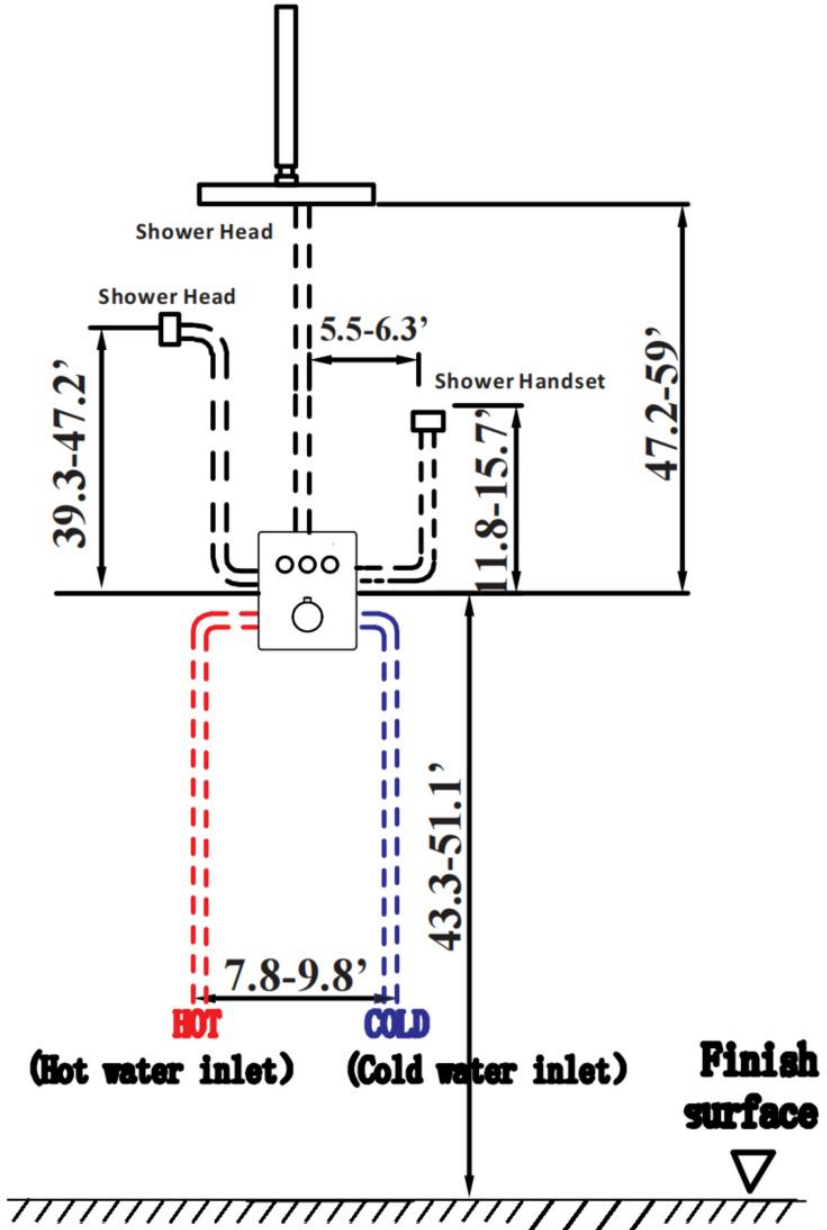

7. Selon les conditions du site et l'exigence de taille d'installation et pour faire un trou, la taille du trou est de 7 pouces (longueur)* 5,5 pouces (largeur) *2,75-3,15 pouces (profond)

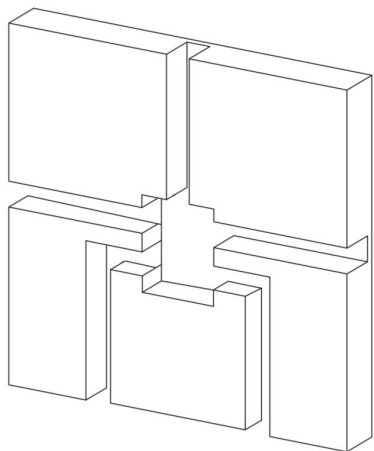

8. Selon les conditions du site et l'installation Dimensions requises pour l'installation du pipeline. (2). Connecter la boîte en plastique au tuyau, placez la boîte en plastique sur le trou, puis ajustez les niveaux (la bulle au milieu du niveleur).(3). Réalisez les trous de positionnement.

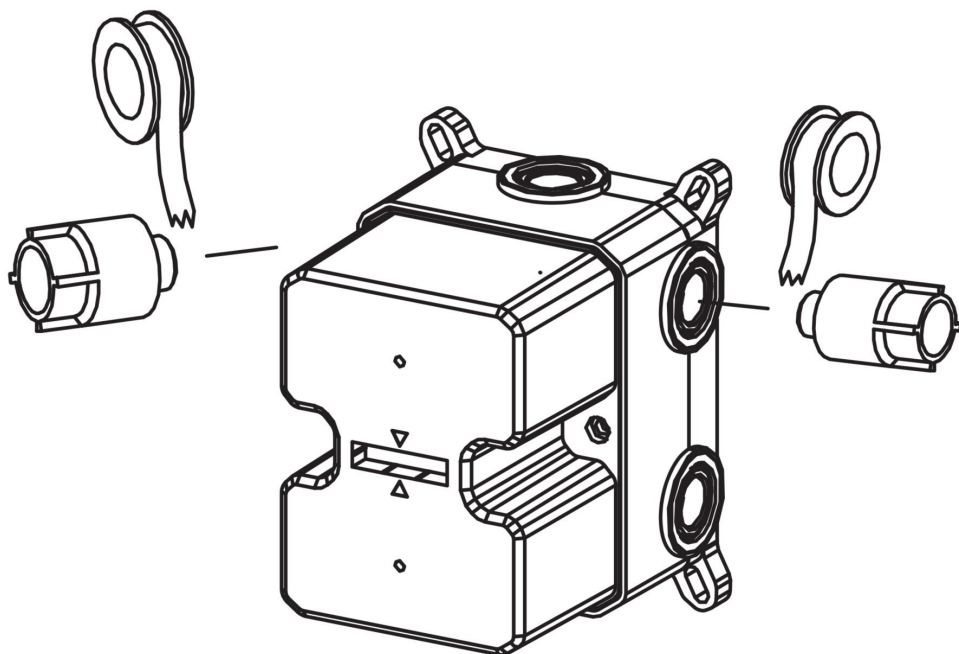

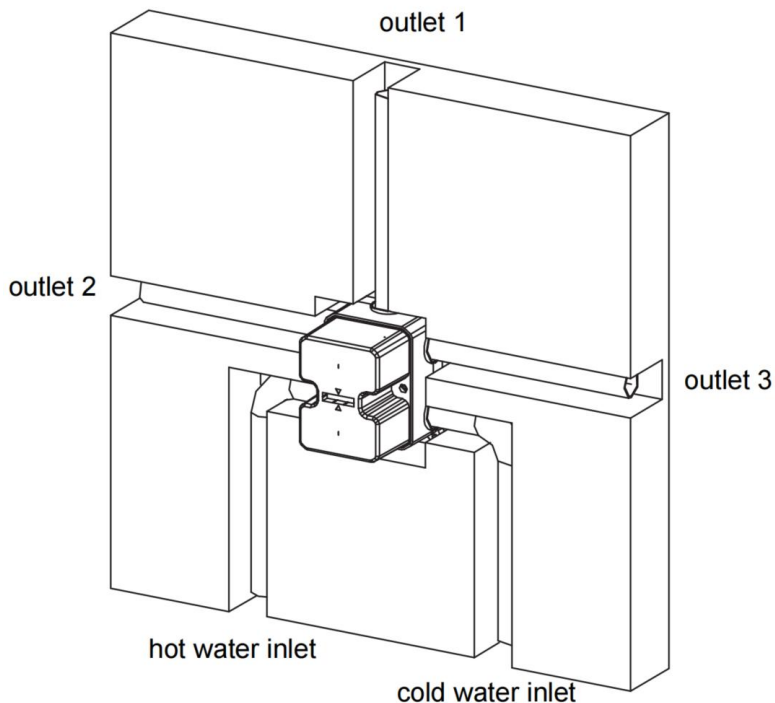

9. Retirez le couvercle de protection lorsque le mur fini est terminé et installez le Fixez l'écusson (B) à la vanne (A) et appuyez-le contre le mur fini. Installez ensuite la poignée (C), serrez les vis de réglage (E) avec la clé Allen (F) et installez la vanne. boutons d'indication (G).

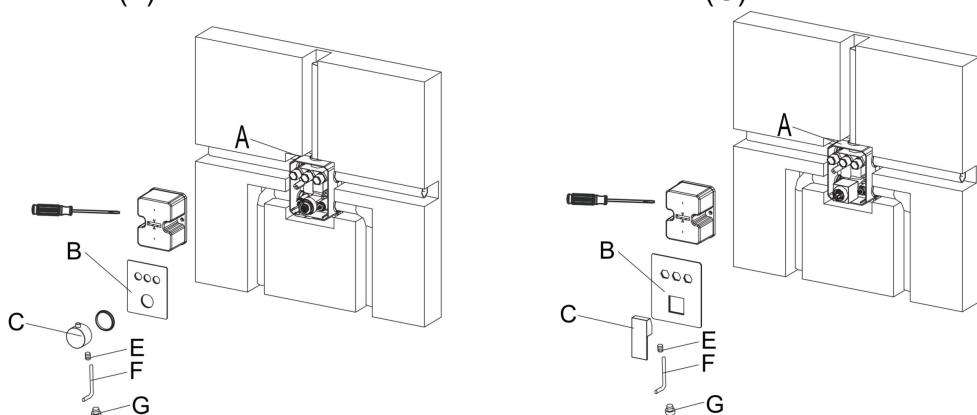

10. Ouvrez l'eau pendant 1 minute pour éliminer les débris. Appliquez du ruban Téflon (H) le tuyau d'échappement fileté et installez le tuyau de douche (I) dans la sortie sur le mur. Ensuite, connectez la douche supérieure (P) au bec .

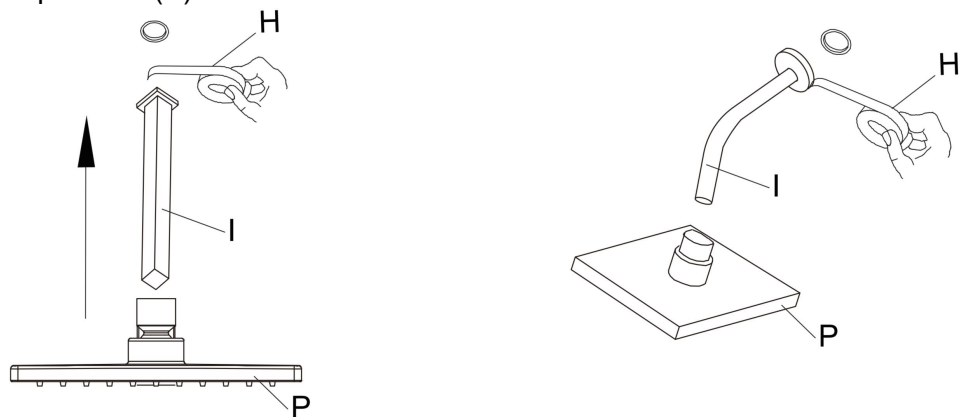

11. Appliquez du ruban Téflon (H) sur l'extrémité fileté, puis fixez le plaque de recouvrement (d) sur le support d'alimentation mural (K) et vissez le support d'alimentation mural (K) dans la sortie de la douchette et vissez (E) avec une clé Allen (F).

12. La distance entre le bas de l'ouverture et la surface du carreau est de 30 mm. Tournez la buse vers la tuyau encastré dans le mur;

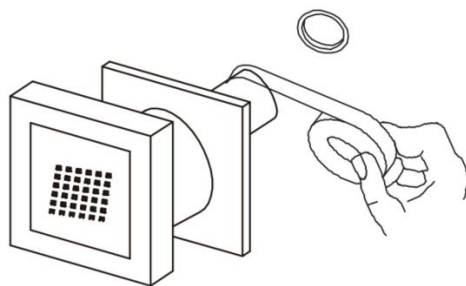
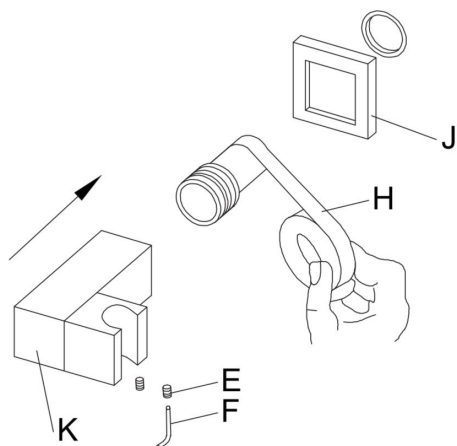

Utilisation du produit

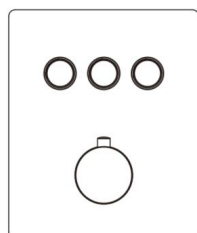

Key switch

Rotating temperature control

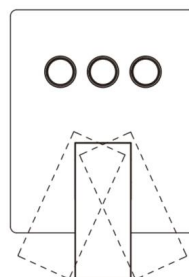

Key switch

Rotating temperature control

CLEANING

3. Pour maintenir de bonnes conditions de travail ou un nettoyage est nécessaire lorsque des gisements minéraux apparaissent sur les buses de pulvérisation. Pour nettoyer les dépôts minéraux ou frotter délicatement les buses en caoutchouc sur visage de pommeau de douche à déloger.

4. Pour nettoyer les dépôts plus importants / retirez la pomme de douche et trempez-la face vers le bas dans une tasse d'eau blanche vinaigre pendant 2 à 3 heures. Remettez le pommeau de douche en place et faites-le tourner à chaque jet pour rincer. vinaigre, NE PAS utiliser de produits chimiques agressifs, de nettoyeurs puissants ou d'abrasifs. Cela pourrait endommager les pièces ou le produit fini et peut annuler la garantie.



Fabricant : Shanghai muxinmuyeyouxiangongsi

Adresse : Shuangchenglu 803nong11hao1602A-1609shi, baoshanqu, Shanghai 200 000 CN.

Importé en Australie : SIHAO PTY LTD. 1 ROKEVA STREET, ASTWOOD NSW 2122 Australie

Importé aux États-Unis : Sanven Technology Ltd. Suite 250, 9166 Anaheim

Lieu, Rancho Cucamonga, CA 91730

UK	REP
-----------	------------

YH CONSULTING LIMITED. C/O YH Consulting Limited Office 147, Centurion House, London Road, Staines-upon-Thames, Surrey, TW18 4AX

EC	REP
-----------	------------

E-CrossStu GmbH
Mainzer Landstr.69,
60329 Frankfurt am Main.



VEVOR

Affordable. Reliable. Home Improvement.

MEHRERE DUSCHKÖPFE

MODELL: FS10282-BN, FS10282-BN-G, FS10282-MB, FS10282-MB-G,
FS10281-CP, FS10281-CP-G, FS10281-BG, FS10281-BG-G,
FS10281-MB, FS10281-MB-G ,
FS10280-BN, FS10280-BN-G, FS10280-MB, FS10280-MB-G,
FS10283-CP, FS10283-CP-G

VEVOR

Affordable. Reliable. Home Improvement.

MULTIPLE SHOWER HEADS

FS10280-BN , FS10280-BN-G
FS10280-MB , FS10280-MB-G

FS10281-CP , FS10281-CP-G
FS10281-BG , FS10281-BG-G
FS10281-MB , FS10281-MB-G

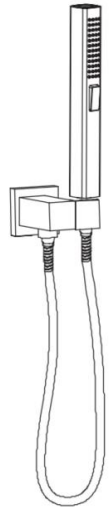
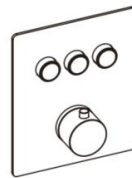
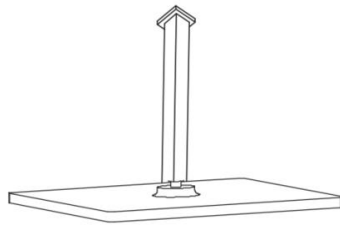
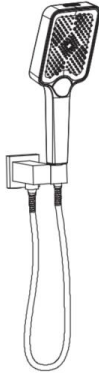
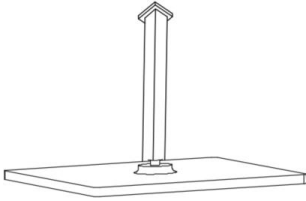

**FS10282-BN, FS10282-BN-G
FS10282-MB, FS10282-MB-G**

FS10283-CP, FS10283-CP-G

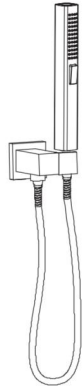
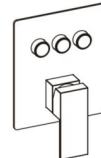
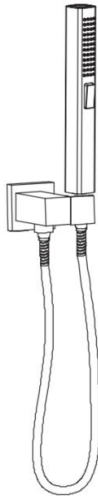
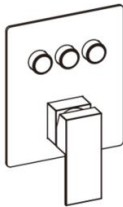
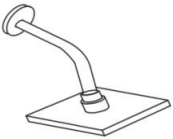
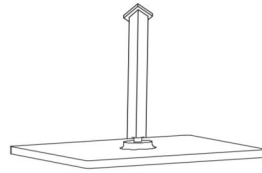
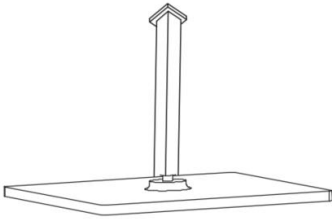

Dies ist die Originalanleitung. Bitte lesen Sie alle Anweisungen sorgfältig durch, bevor Sie das Gerät in Betrieb nehmen. VEVOR behält sich eine klare Auslegung unserer Bedienungsanleitung vor. Das Aussehen des Produkts hängt vom gelieferten Produkt ab. Bitte haben Sie Verständnis dafür, dass wir Sie nicht erneut über Technologie- oder Software-Updates



Warnung: Um das Verletzungsrisiko zu verringern, muss der Benutzer die Bedienungsanleitung sorgfältig lesen.

informieren.

INSTRUCTIONS

Warnhinweise :

17. Tragen Sie während der Montage am besten Handschuhe, um zu verhindern, dass scharfe Ecken des Panels die Handfläche zerkratzen.
18. Achten Sie bei der Installation der Dusche darauf, dass alle Verbindungen vollständig festgezogen sind, um Wasserlecks zu vermeiden.
19. Wenn die Dusche nicht benutzt wird, schließen Sie bitte das Umschaltventil der Dusche.
20. Keine Haftung für die folgenden Ansprüche : 1. Schäden und/oder Ausfälle, die durch unsachgemäße Verwendung und/oder Wartung verursacht wurden; oder durch nicht autorisierte Umbauten; einschließlich Schäden, die durch Missbrauch verursacht wurden (zB Stürze, Tropfen usw.) 2. Beauftragen Sie einen professionellen Klempner. Keine Haftung für Schäden und/oder Ausfälle, die durch eine falsche Installation entstehen. 3. Schäden und/oder Fehler, die durch die Entfernung nach der Installation oder andere Faktoren verursacht wurden.
21. Schäden und/oder Ausfälle, die durch Anwendungen außerhalb des Verwendungszwecks verursacht werden.
22. Schäden und/oder Ausfälle durch Sand, Staub und andere Verunreinigungen
23. Schäden und/oder Ausfälle durch unsachgemäße/unzureichende Wartung; Rostoberflächenbehandlung usw.
24. Schäden und/oder Ausfälle durch Feuer, Erdbeben, Überschwemmung, Blitzschlag und andere Naturkatastrophen, Umweltverschmutzung, schädliche Gase, Salz, anormale Spannung und andere Faktoren.

Vorsichtsmaßnahmen bei der Installation.

1. Reinigen Sie vor dem Einbau der Spule das im Rohr verbleibende Schmutzwasser, Rückstände, Sand und Verunreinigungen. Öffnen Sie die Schutzabdeckung nicht vor dem Einbau der Spule, um Verunreinigungen zu vermeiden.
2. Wasserhähne sowie Warm- und Kaltwasserleitungen müssen korrekt installiert werden. Schließen Sie mit Blick auf den Wasserhahn links Warmwasser und rechts Kaltwasser an.
3. Überprüfen Sie die Einbaumaße. Um Beschädigungen zu vermeiden, sollten

Sie das Produkt nicht mit Gewalt einbauen. So reinigen Sie einen Duschkopf: Um die Helligkeit und die gute Leistung der Dusche zu erhalten, pflegen Sie die Dusche bitte wie folgt:

- g. Nur mit Wasser abspülen und mit einem weichen Baumwolltuch trocknen.
- h. Legen Sie den Duschkopf in einen Topf und füllen Sie diesen mit so viel weißem Essig, dass der Duschkopf bedeckt ist. Die Säure im Essig hilft, die Ablagerungen auf der weißen Mineraldüse aufzulösen. Lassen Sie den Duschkopf 30 Minuten im Essig einweichen. Je schmutziger der Duschkopf, desto länger müssen Sie ihn im Essig einweichen.
- i. Milder flüssiger und farbloser Glasreiniger zum Entfernen von oberflächlichem Schmutz und Schmutzfilm, kein abrasives Poliermittel 4. Verwenden Sie keine säurehaltigen Reinigungsmittel, unlöslichen körnigen Reinigungsmittel, Seife usw.

BEWAHREN SIE DIESE ANWEISUNGEN AUF

INSTALLATION INSTRUCTIONS

Modell	FS10280	FS10281	FS10282	FS10283
Steuerventil	Gemeinsame Temperatur	Konstante Temperatur	Gemeinsame Temperatur	Gemeinsame Temperatur
Kopf Dusche	12 Zoll	12 Zoll	10 Zoll	10 Zoll
Kopf Dusche	Quadrat	Streifen	Streifen	Streifen
Arm' s Dusche	6 Zoll	6 Zoll	6 Zoll	Null
Zurück ' s Dusche	Null	Null	Null	2 Zoll
Durchflussrate Beschreibung	2,2 GPM (8,3 l / min)			
Rohrgewinde	Null = NPT1/2" -G = G1/2"			
Farbe	-B N = Gebürstetes Nickel, -M B = Mattschwarz , -B G=Gebürstetes Gold, -C P=Verchromt,			

PARTS LIST

Werkzeuge, die Sie möglicherweise benötigen



Wrench







Screwdriver



Teflon Tape

Zubehör installieren

Sechskantschlüssel (1 Stück)	Teflonband (1 Stück)	Schrauben (4 Stück)	Bolzen (4 Stück)	Wohnung (4 Stück)
				

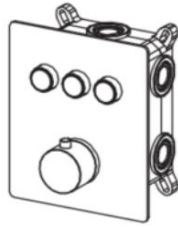

FS10281

Parts included

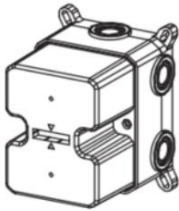

① Faucet Body

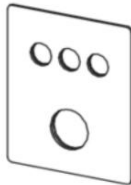

② Panel



③ Showerhead



④ Shower arm



⑤ Showerhead

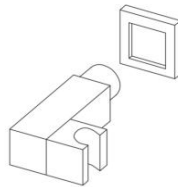

⑥ Shower Socket



⑦ Shower Hose

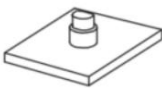

⑧ Showerhead

+



⑨ Shower arm

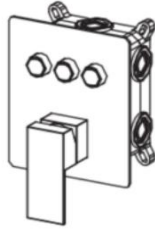

FS10280
FS10282
FS10283

Parts included

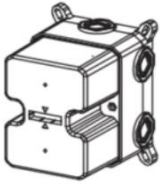

① Faucet Body

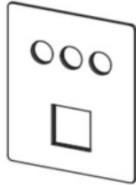

② Panel



③ Handle



④ Showerhead



⑤ Shower arm

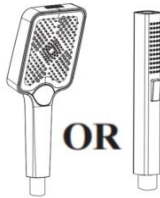

⑥ Showerhead

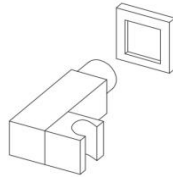

⑦ Shower Socket



⑧ Shower Hose

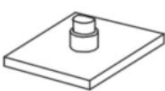

⑨ Showerhead

+



⑩ Shower arm

OR

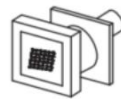

⑨ Back Spray*6

INSTALLATION STEPS

Empfohlene Einbaumaße

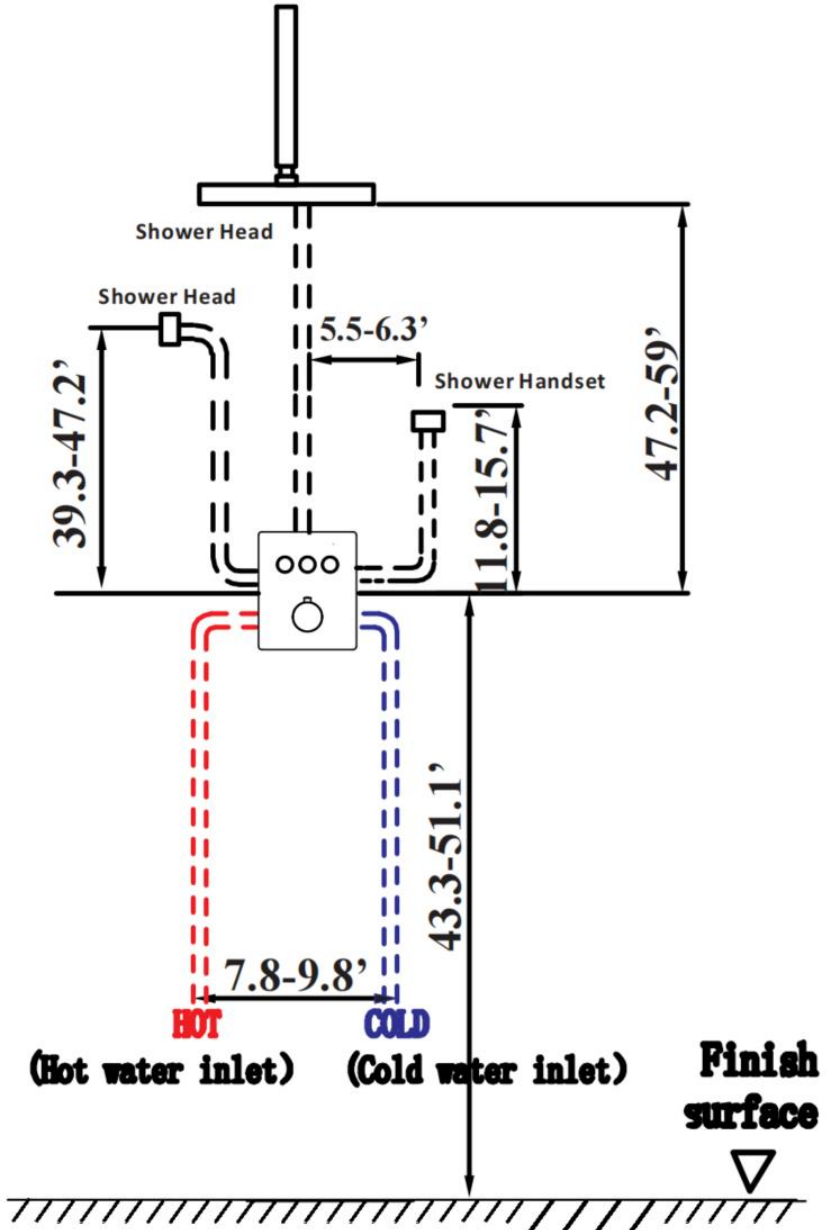

13. Je nach Standortbedingungen und die erforderliche Installationsgröße und um ein Loch zu machen, ist die Lochgröße 7 Zoll (Länge)* 5,5 Zoll (Breite) *2,75-3,15 Zoll (tief)

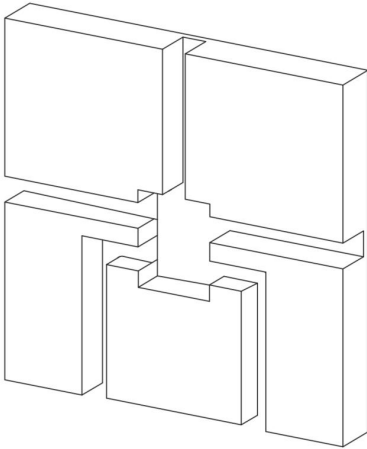

14. Je nach Standortbedingungen und Installation Größenanforderung zum Einrichten der Rohrleitung. (2). Verbinden die Plastikbox an das Rohr, setzen Sie die Plastikbox auf die Loch, dann passen Sie die Ebenen an (die Blase in der Mitte der Überladebrücke).(3). Bohren Sie die Positionierungslöcher.

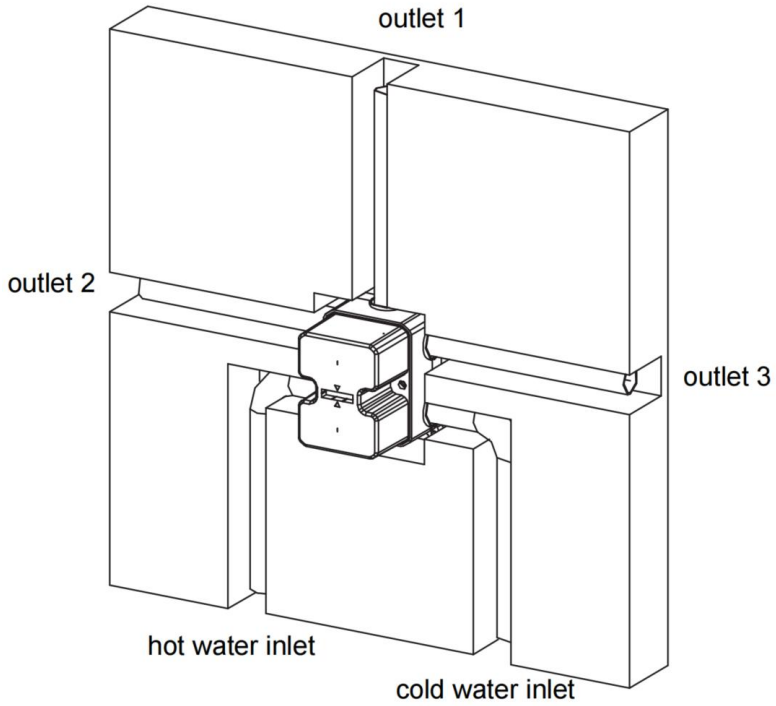
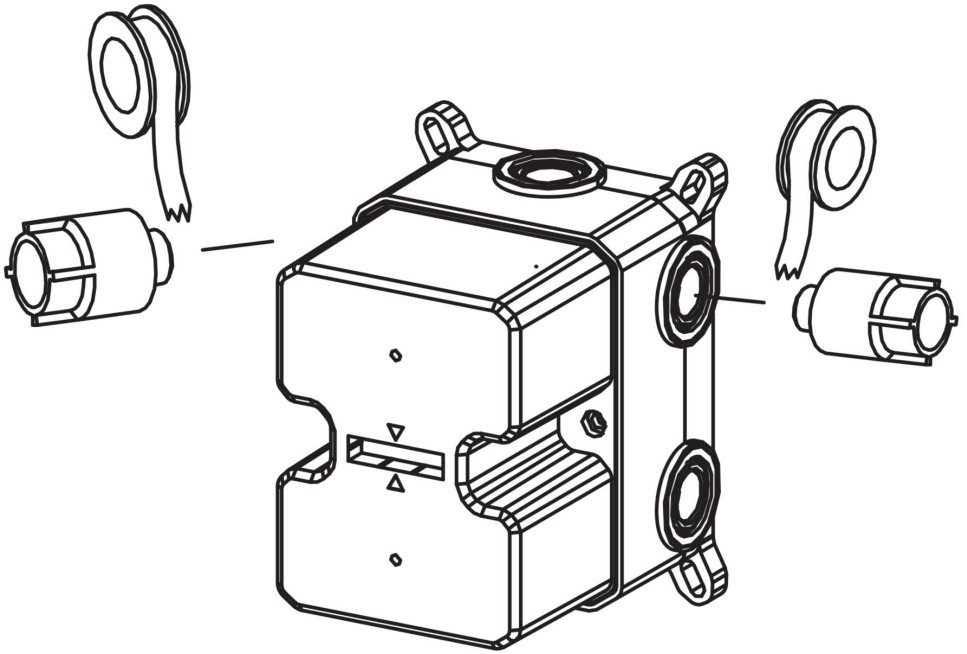

15. Entfernen Sie die Schutzabdeckung, wenn die fertige Wand fertiggestellt ist, und installieren Sie die Rosette (B) auf das Ventil (A) aufstecken und gegen die fertige Wand drücken. Anschließend den Griff (C) montieren, die Stellschrauben (E) mit dem Inbusschlüssel (F) festziehen und die Anzeigetasten (G).

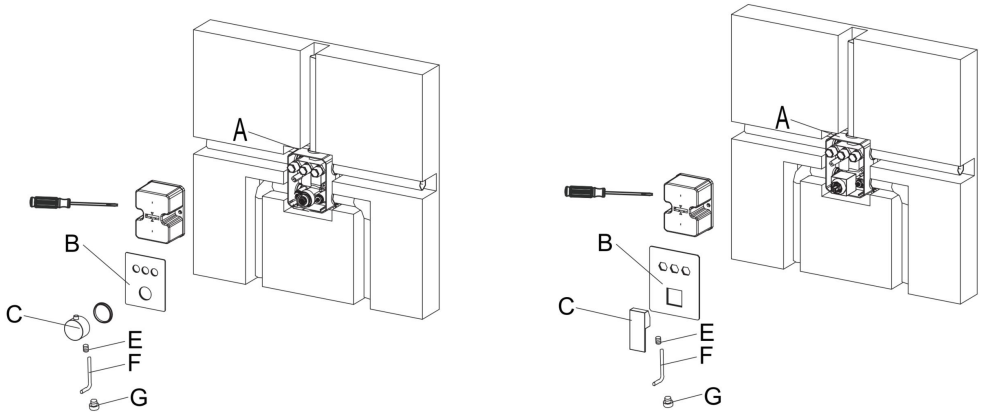

16. Drehen Sie das Wasser für 1 Minute auf, um alle Rückstände auszuspülen. Bringen Sie Teflonband (H) an das Gewinde-Endrohr und installieren Sie den Brauseschlauch (I) im Auslass an der Wand. Schließen Sie dann die obere Brause (P) an den Auslauf an .

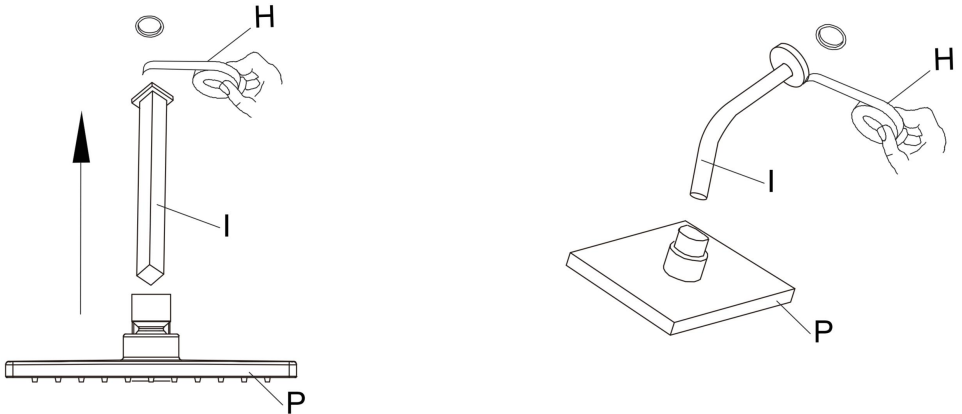

17. Tragen Sie Teflonband (H) auf das Gewindeende auf und fixieren Sie das

18. Der Abstand zwischen Boden der Öffnung und die Oberfläche der Fliese

Abdeckplatte (d) auf den Wandversorgungshalter (K) stecken und anschrauben Den Wandanschlusshalter (K) in den Handbrausenabgang stecken und mit einem Inbusschlüssel (E) festschrauben (F).

ist 30mm.Drehen Sie die Düse auf die Rohr eingebettet in der Wand;

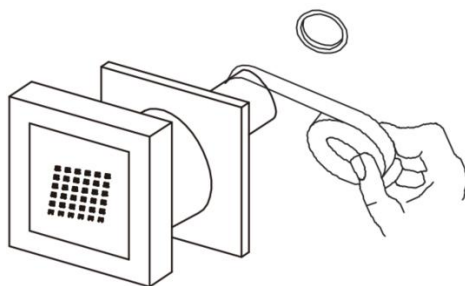
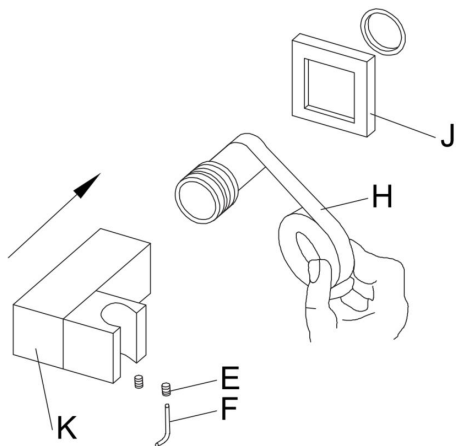

Produktverwendung

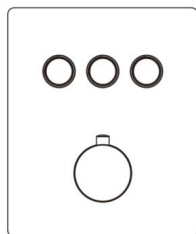

Key switch

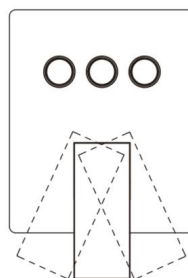

Key switch

Rotating temperature control

Rotating temperature control

CLEANING

5. Um ordnungsgemäße Arbeitsbedingungen oder Reinigung ist erforderlich, wenn Mineralablagerungen erscheinen auf Sprühdüsen. Um Mineralablagerungen zu reinigen oder sanft Gummidüsen auf der Gesicht von Duschkopf kann sich lösen.

6. Um stärkere Ablagerungen zu entfernen , nehmen Sie den Duschkopf ab und legen Sie ihn mit dem Gesicht nach unten in eine Tasse Essig für 2-3 Stunden. Setzen Sie den Duschkopf wieder auf und lassen Sie jede Sprüheinstellung laufen, um Essig, verwenden Sie KEINE aggressiven Chemikalien / Hochleistungsreiniger oder Scheuermittel. Dies kann Teile oder das fertige Produkt beschädigen und zum Erlöschen der Garantie führen.

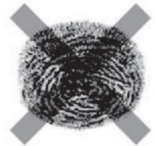

Hersteller: Shanghaimuxinmuyeyouxiangongsi

Adresse: Shuangchenglu 803nong11hao1602A-1609shi, baoshanqu, Shanghai 200000 CN.

Importiert nach AUS: SIHAO PTY LTD. 1 ROKEVA STREETEASTWOOD NSW 2122 Australien

Importiert in die USA: Sanven Technology Ltd. Suite 250, 9166 Anaheim Place, Rancho Cucamonga, CA 91730

UK	REP
-----------	------------

YH CONSULTING LIMITED. C/O YH Consulting
Limited Office 147, Centurion House, London
Road, Staines-upon-Thames, Surrey, TW18 4AX

EC	REP
-----------	------------

E-CrossStu GmbH
Mainzer Landstr.69,
60329 Frankfurt am Main.



VEVOR

Affordable. Reliable. Home Improvement.

SOFFIONI DOCCIA MULTIPLI

MODELLO: FS10282-BN, FS10282-BN-G, FS10282-MB, FS10282-MB-G,
FS10281-CP, FS10281-CP-G, FS10281-BG, FS10281-BG-G,
FS10281-MB, FS10281-MB-G ,
FS10280-BN, FS10280-BN-G, FS10280-MB, FS10280-MB-G,
FS10283-CP, FS10283-CP-G

VEVOR

Affordable. Reliable. Home Improvement.

MULTIPLE SHOWER HEADS

FS10280-BN , FS10280-BN-G
FS10280-MB , FS10280-MB-G

FS10281-CP , FS10281-CP-G
FS10281-BG , FS10281-BG-G
FS10281-MB , FS10281-MB-G

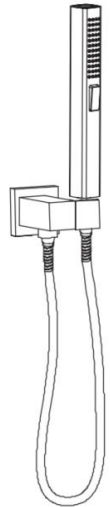
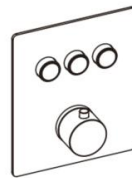
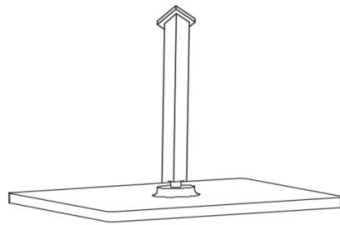
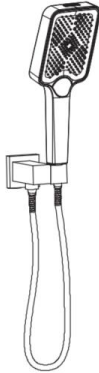
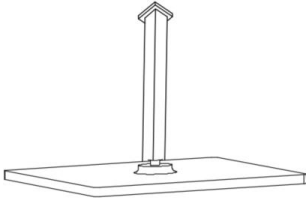

**FS10282-BN, FS10282-BN-G
FS10282-MB, FS10282-MB-G**

FS10283-CP, FS10283-CP-G

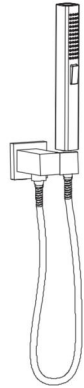
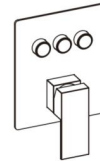
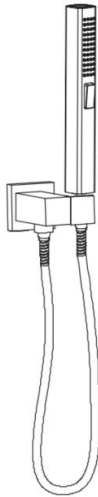
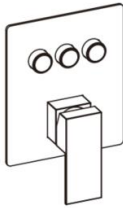
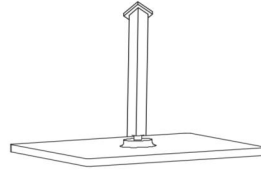
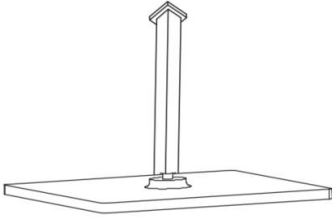

Queste sono le istruzioni originali, si prega di leggere attentamente tutte le istruzioni del manuale prima dell'uso. VEVOR si riserva la piena interpretazione del proprio manuale utente. L'aspetto del prodotto dipenderà dal prodotto ricevuto. Vi preghiamo di scusarci se non vi informeremo più in caso di aggiornamenti tecnologici o software sul nostro



Avvertenza: per ridurre il rischio di lesioni, l'utente deve leggere attentamente il manuale di istruzioni.

prodotto.

INSTRUCTIONS

Suggerimenti di avvertimento :

25. Durante l'installazione è consigliabile indossare dei guanti per evitare che gli angoli taglienti del pannello graffino il palmo della mano.
26. Durante l'installazione della doccia, assicurarsi che tutti i giunti siano ben serrati per evitare perdite d'acqua.
27. Quando la doccia non è in uso, chiudere la valvola di commutazione della doccia.
28. Non sarà ritenuto responsabile per nessuna delle seguenti rivendicazioni : 1. Danni e/o guasti causati da uso e/o manutenzione impropri; o qualsiasi ricostruzione non autorizzata; inclusi eventuali danni causati da abuso (ad esempio cadute, cadute, ecc.) 2. Assumere un idraulico professionista. Non ci assumiamo alcuna responsabilità per eventuali danni e/o guasti causati da un'installazione errata. 3. Danni e/o guasti causati dalla rimozione dopo l'installazione o da altri fattori.
29. Danni e/o guasti causati da applicazioni che esulano dall'ambito di utilizzo.
30. Danni e/o guasti causati da sabbia, polvere e altre impurità
31. Danni e/o guasti causati da manutenzione impropria/inadeguata; trattamento superficiale antiruggine, ecc.
32. Danni e/o guasti causati da incendi, terremoti, inondazioni, fulmini e altri disastri naturali, inquinamento, gas nocivi, sale, tensione anomala e altri fattori.

Precauzioni per l'installazione.

1. Prima di installare la bobina, pulire l'acqua sporca, i residui, la sabbia e le impurità rimaste nel tubo prima di installare la bobina. Non aprire il coperchio protettivo prima di installare la bobina per evitare impurità.
2. I rubinetti e le tubature dell'acqua calda e fredda devono essere installati correttamente. Guardando il rubinetto, collegare l'acqua calda a sinistra e l'acqua fredda a destra.
3. Controllare le dimensioni di installazione. Non forzare l'installazione del prodotto per evitare di danneggiare i componenti. Come pulire un soffione doccia: per mantenere la luminosità esterna e le buone prestazioni della doccia, si prega di prendersene cura come segue:

- j. Risciacquare solo con acqua e asciugare con un panno morbido di cotone.
- k. Metti il soffione della doccia in una pentola e riempila con aceto bianco a sufficienza per coprirlo completamente. L'acido contenuto nell'aceto aiuta a sciogliere i depositi sull'ugello minerale bianco. Lascia il soffione della doccia in ammollo nell'aceto per 30 minuti. Più il soffione della doccia è sporco, più a lungo dovrai lasciarlo in ammollo nell'aceto.
- l. Per rimuovere lo sporco superficiale e la pellicola di sporco è possibile utilizzare un detergente per vetri liquido delicato e incolore, non un agente lucidante abrasivo.
4. Non utilizzare detersivi acidi, detersivi granulari insolubili, saponi, ecc.

CONSERVARE QUESTE ISTRUZIONI

INSTALLATION INSTRUCTIONS

Modello	FS10280	FS10281	FS10282	FS10283
Valvola di controllo	Temperatura comune	Temperatura costante	Temperatura comune	Temperatura comune
Testa Doccia	12 pollici	12 pollici	10 pollici	10 pollici
Testa Doccia	Piazza	Striscia	Striscia	Striscia
Doccia Arm 's	6 pollici	6 pollici	6 pollici	Nulla
Doccia di schiena	Nulla	Nulla	Nulla	2 pollici
Descrizione della portata	2 . 2 GPM (8 . 3 L/min)			
Filettature per tubi	Nulla = NPT1/2" -G = G1/2"			
Colore	-B N=Nichel spazzolato, -M B= Nero opaco , -B G=Oro spazzolato, -C P=Cromatura,			

PARTS LIST

Strumenti di cui potresti aver bisogno



Wrench



Screwdriver



Teflon Tape

Installare gli accessori

Chiave esagonale (1 pz)	Nastro in teflon (1 pz)	Viti (4 pezzi)	Bullone (4 pezzi)	Piatto (4 pezzi)
				

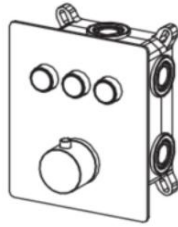

FS10281

Parts included

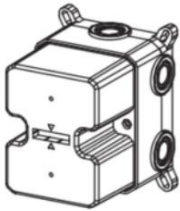

① Faucet Body

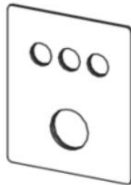

② Panel



③ Showerhead



④ Shower arm



⑤ Showerhead

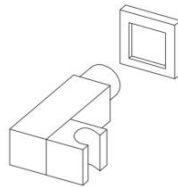

⑥ Shower Socket



⑦ Shower Hose

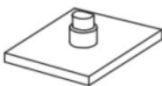

⑧ Showerhead

+



⑨ Shower arm

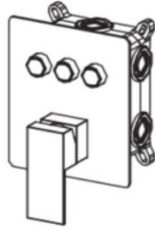

FS10280
FS10282
FS10283

Parts included

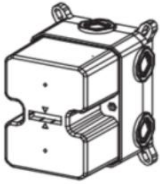

① Faucet Body

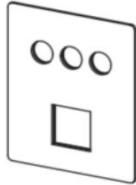

② Panel



③ Handle



④ Showerhead



⑤ Shower arm

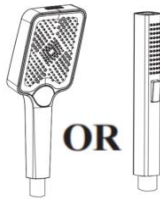

OR



⑥ Showerhead

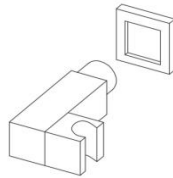

⑦ Shower Socket



⑧ Shower Hose

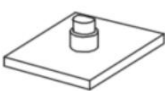

⑨ Showerhead

+

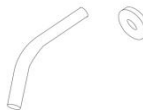

⑩ Shower arm

OR

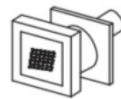

⑨ Back Spray*6

INSTALLATION STEPS

Suggerisci la dimensione di installazione

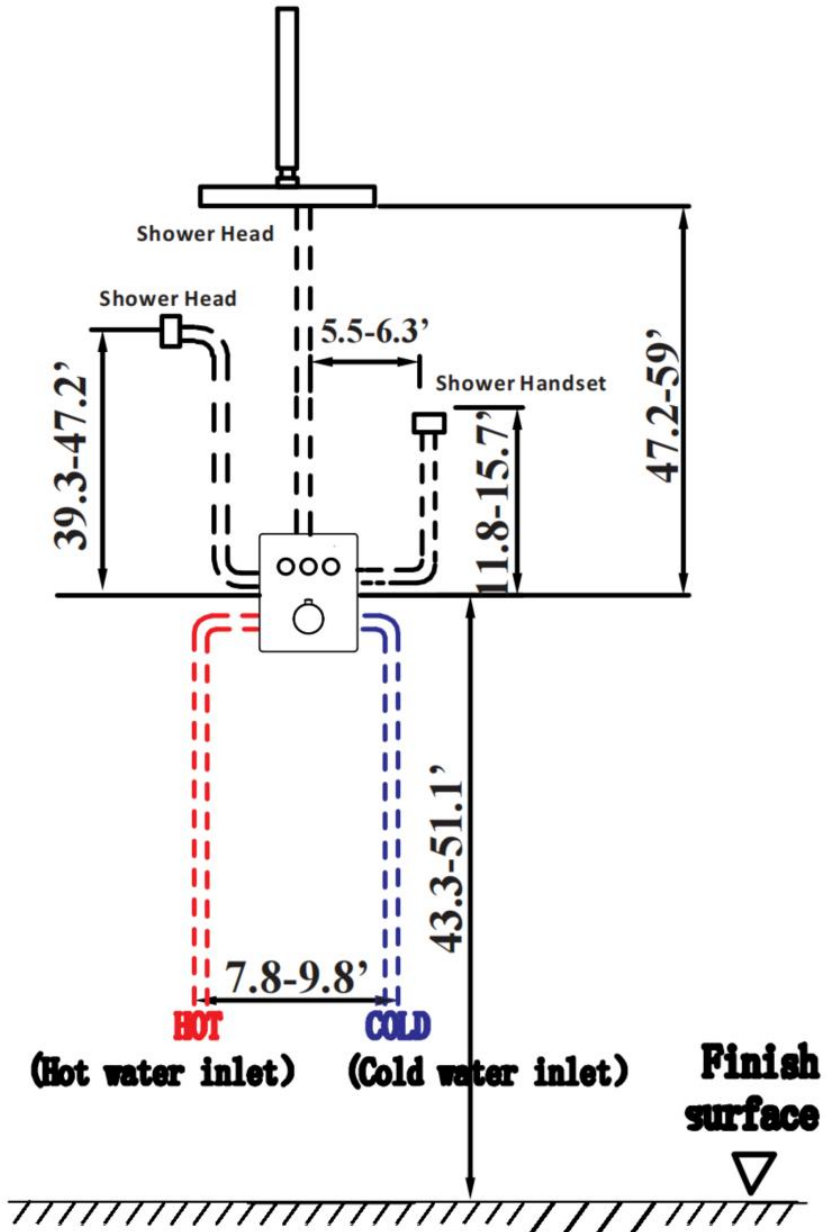

19. Secondo le condizioni del sito e il requisito di dimensione dell'installazione e per fare un foro, la dimensione del foro è 7 pollici (lunghezza)* 5,5 pollici (larghezza) *2,75-3,15 pollici (profondo)

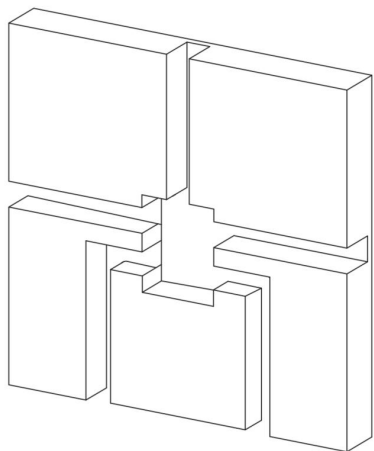

20. In base alle condizioni del sito e all'installazione requisito di dimensione per installare la tubazione. (2). Collegare la scatola di plastica al tubo, mettere la scatola di plastica sul buco, quindi regola i livelli (la bolla al centro del livellatore).(3). Eseguire i fori di posizionamento.

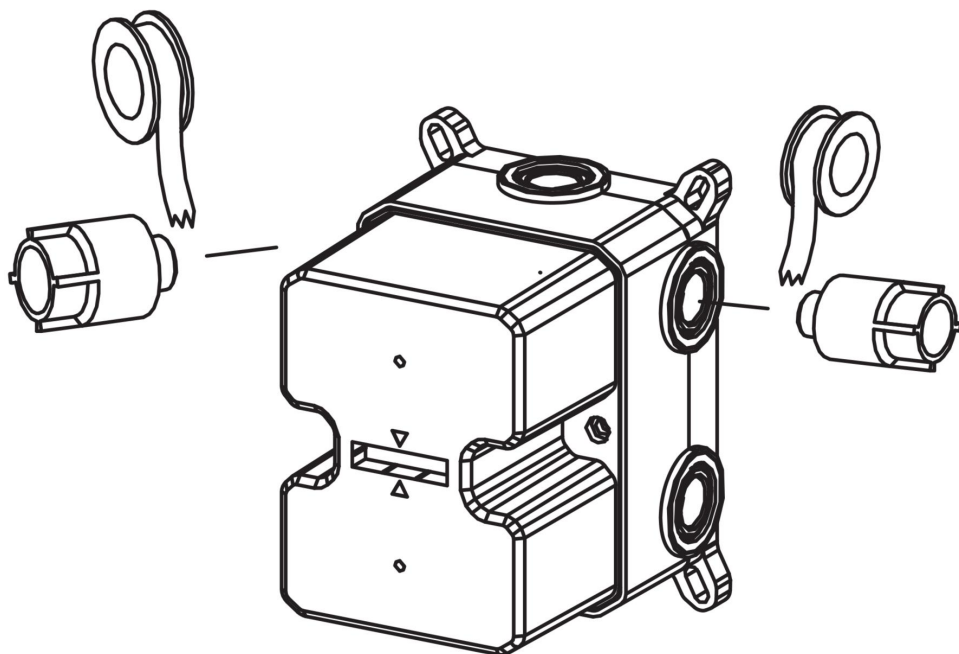

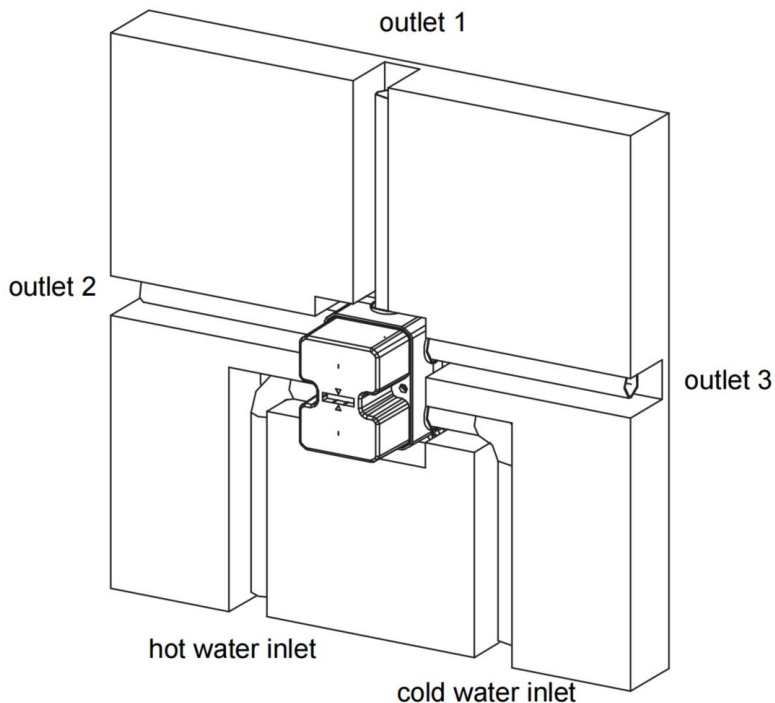

21. Rimuovere la copertura protettiva una volta completata la parete finita e installare la rosetta (B) alla valvola (A) e premerla contro la parete finita. Quindi, installare la maniglia (C), serrare le viti di fissaggio (E) con la chiave a brugola (F) e posizionare pulsanti di indicazione (G).

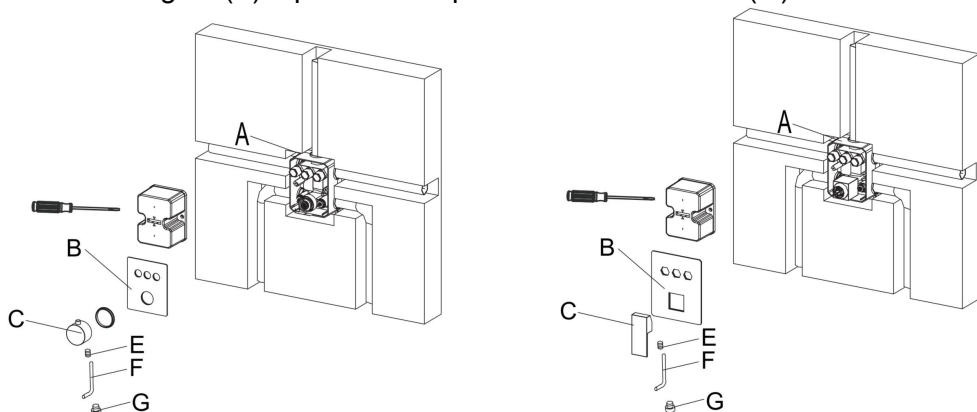

22. Aprire l'acqua per 1 minuto per eliminare eventuali detriti. Applicare il nastro in Teflon (H) il tubo di scarico filettato e installare il tubo flessibile della doccia (I) nella presa a parete (P). Quindi collegare la doccia superiore (P) al beccuccio .

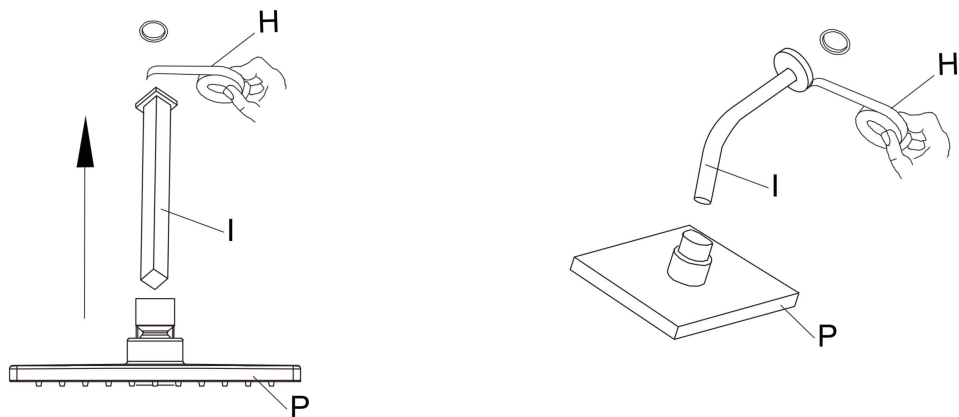

23. Applicare il nastro in Teflon (H) all'estremità filettata, quindi fissare il piastra di copertura (d) sul supporto di alimentazione a parete (K) e avvitare il supporto di alimentazione a parete (K) nell'uscita della doccetta e avvitare (E) con la chiave a brugola (F).

24. La distanza tra il fondo dell'apertura e la superficie della piastrella è di 30 mm. Ruotare l'ugello verso tubo incorporato nel muro;

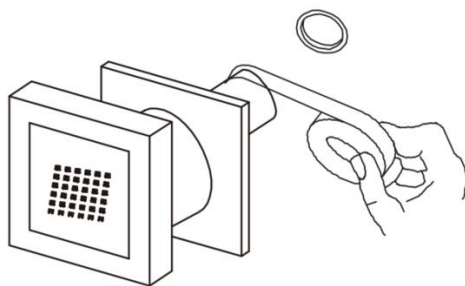
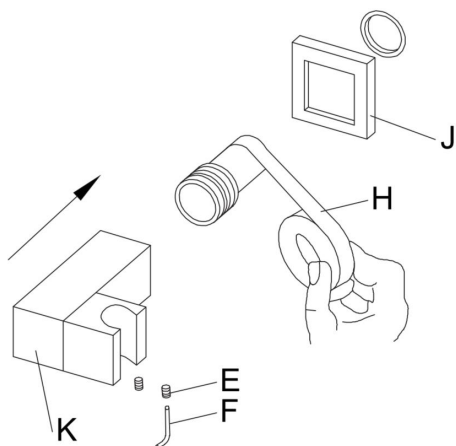

Utilizzo del prodotto

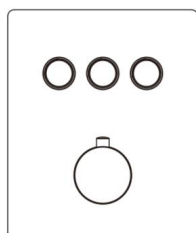

Key switch

Rotating temperature control

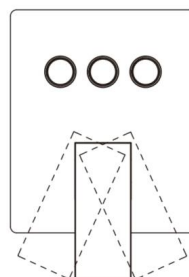

Key switch

Rotating temperature control

CLEANING

7. Per mantenere le condizioni di lavoro adeguate o la pulizia è necessaria quando i depositi minerali appaiono sugli ugelli di spruzzatura. Per pulire i depositi minerali o strofinare delicatamente gli ugelli di gomma sul faccia di soffione della doccia per staccarlo.

8. Per pulire i depositi più ostinati / rimuovere il soffione della doccia e immergerlo a faccia in giù in una tazza di bianco aceto per 2-3 ore. Riposizionare il soffione della doccia e far funzionare ogni getto per sciacquare aceto, NON utilizzare prodotti chimici aggressivi / detersivi pesanti o abrasivi. Questo potrebbe danneggiare parti o il prodotto finito e potrebbe invalidare la garanzia.



Produttore: Shanghaimuxinmuyeyouxiangongsi

Indirizzo: Shuangchenglu 803nong11hao1602A-1609shi, baoshanqu, Shanghai 200000 CN.

Importato in AUS: SIHAO PTY LTD. 1 ROKEVA STREETEASTWOOD
Nuovo Galles del Sud 2122 Australia

Importato negli USA: Sanven Technology Ltd. Suite 250, 9166 Anaheim
Luogo, Rancho Cucamonga, CA 91730

UK	REP
-----------	------------

YH CONSULTING LIMITED. C/O YH Consulting
Limited Office 147, Centurion House, London
Road, Staines-upon-Thames, Surrey, TW18 4AX

EC	REP
-----------	------------

E-CrossStu GmbH
Mainzer Landstr.69,
60329 Frankfurt am Main.



VEVOR

Affordable. Reliable. Home Improvement.

CABEZALES DE DUCHA MÚLTIPLES

MODELO: FS10282-BN, FS10282-BN-G, FS10282-MB, FS10282-MB-G,
FS10281-CP, FS10281-CP-G, FS10281-BG, FS10281-BG-G,
FS10281-MB, FS10281-MB-G ,
FS10280-BN, FS10280-BN-G, FS10280-MB, FS10280-MB-G,
FS10283-CP, FS10283-CP-G

VEVOR

Affordable. Reliable. Home Improvement.

MULTIPLE SHOWER HEADS

FS10280-BN , FS10280-BN-G
FS10280-MB , FS10280-MB-G

FS10281-CP , FS10281-CP-G
FS10281-BG , FS10281-BG-G
FS10281-MB , FS10281-MB-G

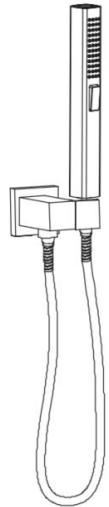
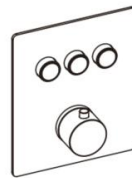
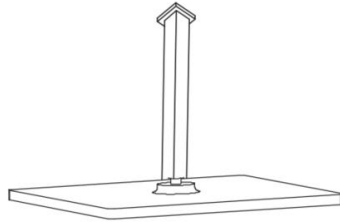
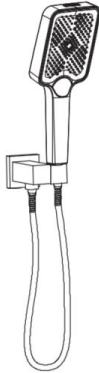
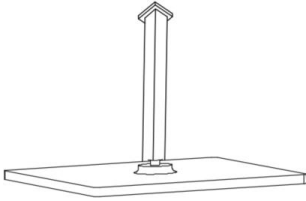

**FS10282-BN, FS10282-BN-G
FS10282-MB, FS10282-MB-G**

FS10283-CP, FS10283-CP-G

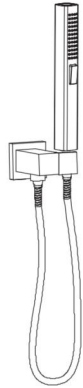
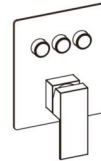
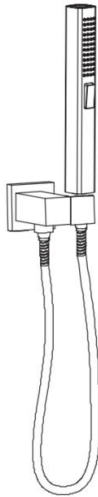
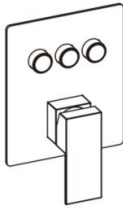
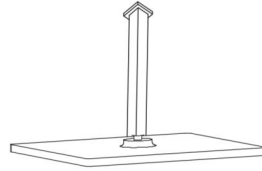
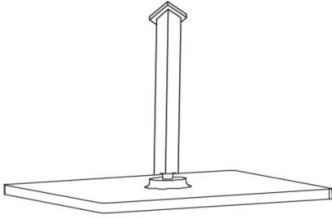

Estas son las instrucciones originales; lea atentamente todas las instrucciones del manual antes de utilizarlo. VEVOR se reserva el derecho de interpretar su manual de usuario. La apariencia del producto dependerá del producto que haya recibido. Le rogamos que nos disculpe si no le informamos de nuevo si hay actualizaciones tecnológicas o de software en



Advertencia: Para reducir el riesgo de lesiones, el usuario debe leer atentamente el manual de instrucciones.

nuestro producto.

INSTRUCTIONS

Consejos de advertencia :

33. Durante el proceso de instalación, es mejor usar guantes para evitar que las esquinas afiladas del panel rayen la palma de la mano.

34. Al instalar la ducha, asegúrese de que todas las juntas estén completamente apretadas para evitar fugas de agua.

35. Cuando la ducha no esté en uso, cierre la válvula de interruptor de la ducha.

36. No será responsable de ninguna de las siguientes reclamaciones : 1. Daños y/o averías causados por uso y/o mantenimiento inadecuado; o cualquier reconstrucción no autorizada; incluido cualquier daño causado por abuso (por ejemplo caídas, gotas, etc.) 2. Contrate a un plomero profesional. No nos hacemos responsables de daños ni averías causadas por una instalación incorrecta. 3. Daños y/o fallas causados por la remoción después de la instalación u otros factores.

37. Daños y/o fallos causados por aplicaciones fuera del ámbito de uso.

38. Daños y/o fallas causados por arena, polvo y otras impurezas

39. Daños y/o fallas causados por mantenimiento inadecuado/incorrecto; Tratamiento de superficies oxidadas, etc.

40. Daños y/o fallas causados por incendios, terremotos, inundaciones, rayos y otros desastres naturales, contaminación, gases nocivos, sal, voltaje anormal y otros factores.

Precauciones de instalación.

1. Antes de instalar el carrete, limpie el agua sucia, los residuos, la arena y las impurezas que queden en la tubería. No abra la cubierta protectora antes de instalar el carrete para evitar impurezas.

2. Los grifos y las tuberías de agua caliente y fría deben estar correctamente instalados. De frente al grifo, conecte el agua caliente a la izquierda y el agua fría a la derecha.

3. Verifique el tamaño de la instalación. No fuerce la instalación para evitar dañar las piezas. Cómo limpiar el cabezal de la ducha: Para mantener el brillo exterior y el buen rendimiento de la ducha, siga estos pasos:

m. Enjuagar sólo con agua y secar con un paño suave de algodón.

n. Coloque el cabezal de la ducha en una olla y llénela con suficiente vinagre blanco para cubrirlo. El ácido del vinagre ayuda a disolver los depósitos en la boquilla mineral blanca. Deje el cabezal de la ducha en remojo en vinagre durante 30 minutos. Cuanto más sucio esté, más tiempo necesitará remojarlo en vinagre.

o. Se puede utilizar un limpiador de vidrios líquido suave e incoloro para eliminar la suciedad de la superficie y la película de suciedad, no un agente de pulido abrasivo.

4. No utilice detergentes ácidos, detergentes granulares insolubles, jabón, etc.

GUARDE ESTAS INSTRUCCIONES

INSTALLATION INSTRUCTIONS

Modelo	FS10280	FS10281	FS10282	FS10283
Válvula de control	Temperatura común	Temperatura constante	Temperatura común	Temperatura común
Cabeza Ducha	12 pulgadas	12 pulgadas	10 pulgadas	10 pulgadas
Cabeza Ducha	Cuadrado	Banda	Banda	Banda
Ducha de brazo	6 pulgadas	6 pulgadas	6 pulgadas	Nulo
Ducha de espalda	Nulo	Nulo	Nulo	2 pulgadas
Descripción del caudal	2,2 GPM (8,3 L / min)			
Roscas de tubería	Nulo= NPT1/2" -G= G1/2"			
Color	-B N=Níquel cepillado, -M B= Negro mate , -B G=Oro cepillado, -C P=Chapado en cromo,			

PARTS LIST

Herramientas que puedes necesitar



Wrench





Screwdriver



Teflon Tape

Instalar accesorios

Instalar accesorios				
Llave hexagonal (1 pieza)	Cinta de teflón (1 pieza)	Tornillos (4 piezas)	Tornillo (4 piezas)	Departamento (4 piezas)
				

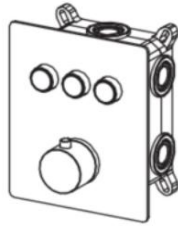

FS10281

Parts included

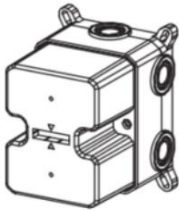

① Faucet Body

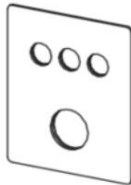

② Panel



③ Showerhead



④ Shower arm



⑤ Showerhead

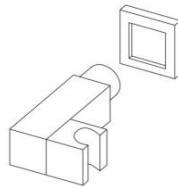

⑥ Shower Socket



⑦ Shower Hose

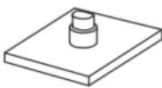

⑧ Showerhead

+

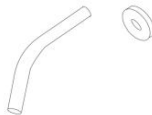

⑨ Shower arm

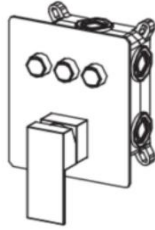

FS10280
FS10282
FS10283

Parts included

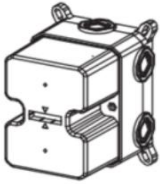

① Faucet Body

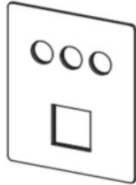

② Panel



③ Handle



④ Showerhead



⑤ Shower arm

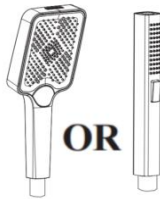

OR



⑥ Showerhead

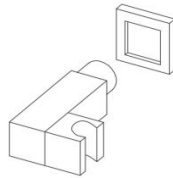

⑦ Shower Socket



⑧ Shower Hose

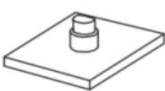

⑨ Showerhead

+

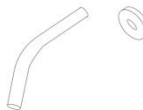

⑩ Shower arm

OR

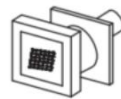

⑨ Back Spray*6

INSTALLATION STEPS

Sugerir dimensión de instalación

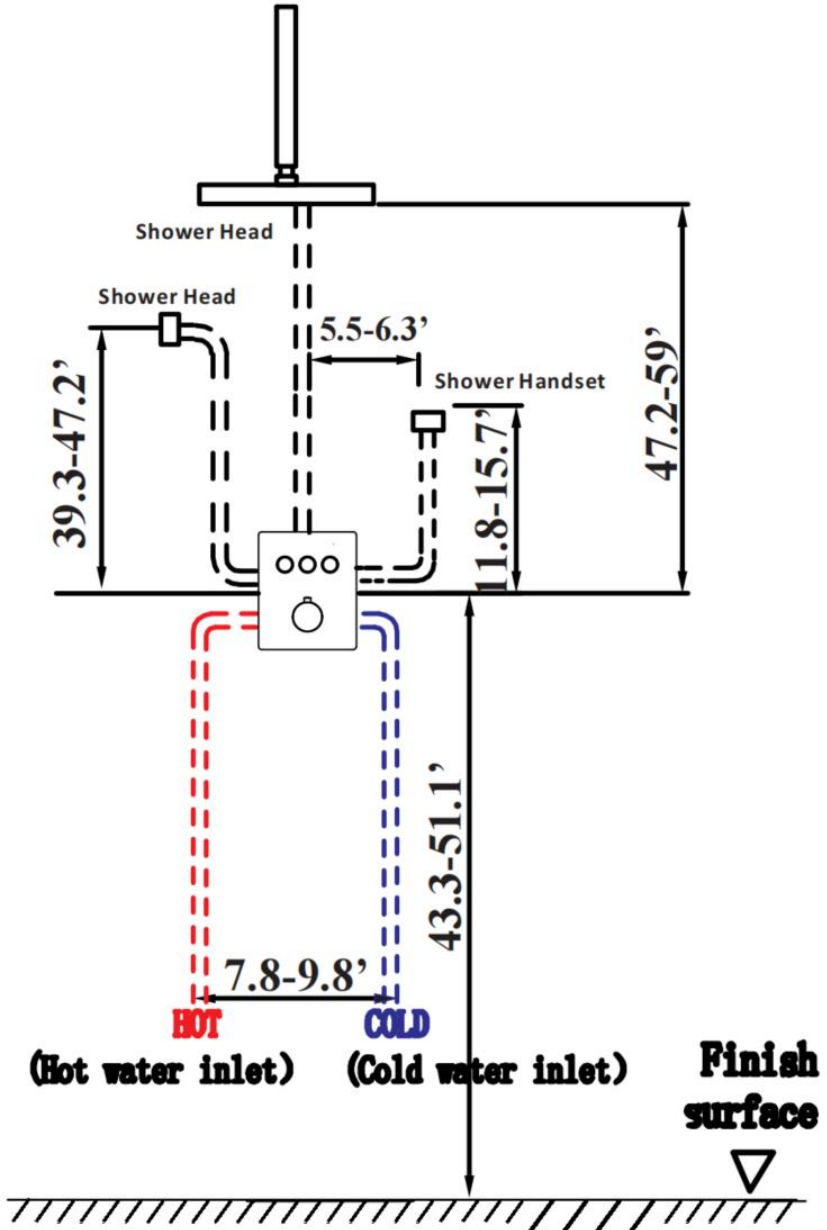

25. Según las condiciones del sitio y el requisito de tamaño de la instalación y para hacer un agujero, el tamaño del agujero es de 7 pulgadas (longitud) * 5,5 pulgadas (ancho) * 2,75-3,15 pulgadas (profundo)

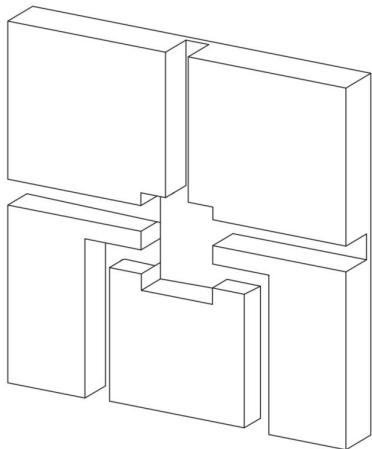

26. Según las condiciones del sitio y la instalación Requisito de tamaño para instalar la tubería. (2). Conectar la caja de plástico a la tubería, coloque la caja de plástico en la agujero, Luego ajuste los niveles (la burbuja en el medio) del nivelador).(3). Realizar los agujeros de posicionamiento.

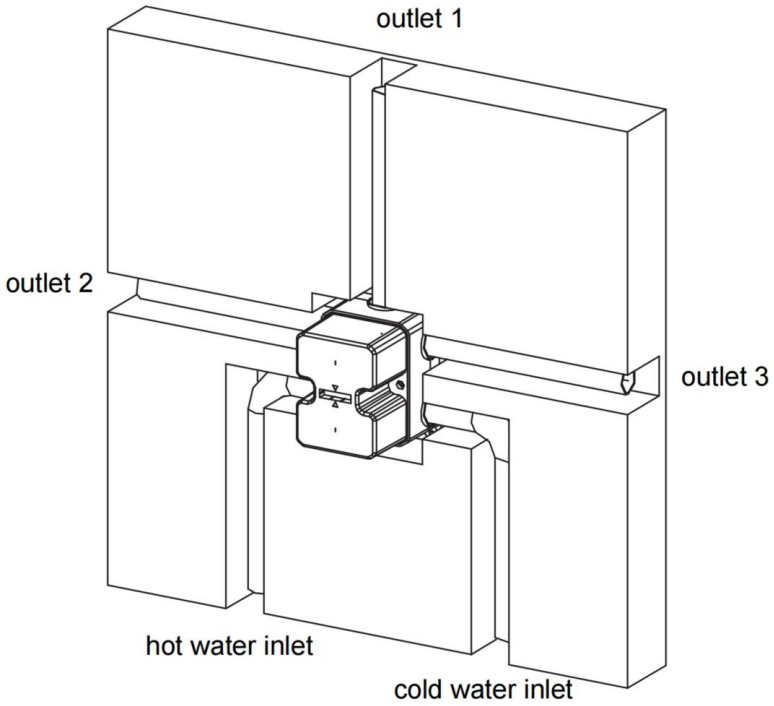
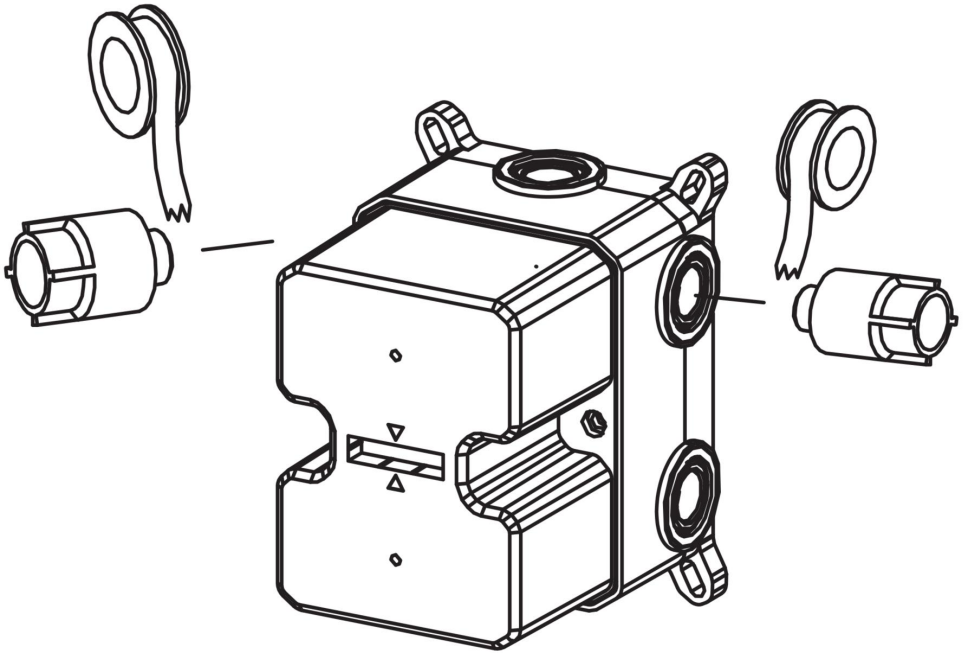

27. Retire la cubierta protectora cuando la pared terminada esté terminada e instale la Coloque el escudo (B) en la válvula (A) y presiónelo contra la pared terminada. Luego, instale la manija (C), apriete los tornillos de fijación (E) con la llave Allen (F) y coloque la Botones de indicación (G).

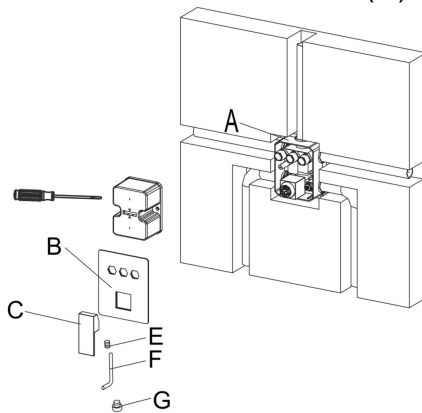
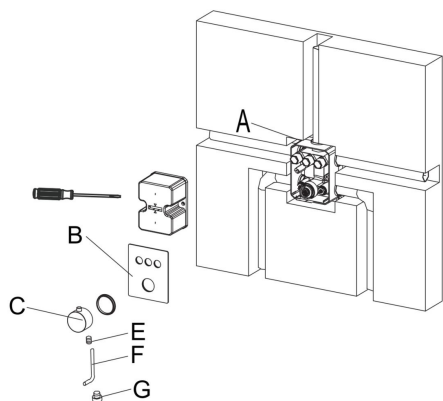

28. Abra el agua durante 1 minuto para eliminar cualquier residuo. Aplique cinta de teflón (H) a el tubo de cola roscado e instale la manguera de la ducha (I) en la salida de la pared. Luego, conecte la ducha superior (P) al caño .

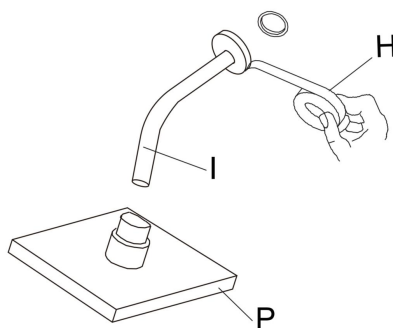
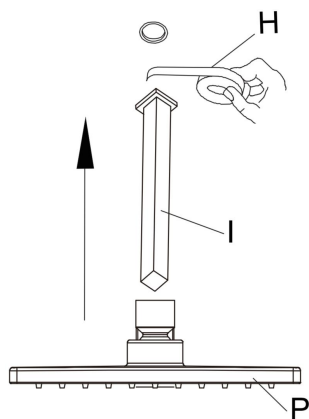

29. Aplique cinta de teflón (H) al extremo roscado y fíjelo. Coloque la placa de cubierta (d) en el soporte de la fuente de

30. La distancia entre el parte inferior de la abertura y La superficie de la baldosa es de 30 mm. Gire la boquilla

alimentación de pared (K) y atorníllela. Coloque el soporte de suministro de pared (K) en la salida de la ducha de mano y atorníllelo (E) con una llave Allen. (F).

hacia la tubería incrustada en la pared;

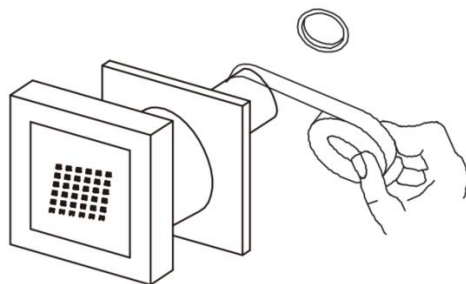
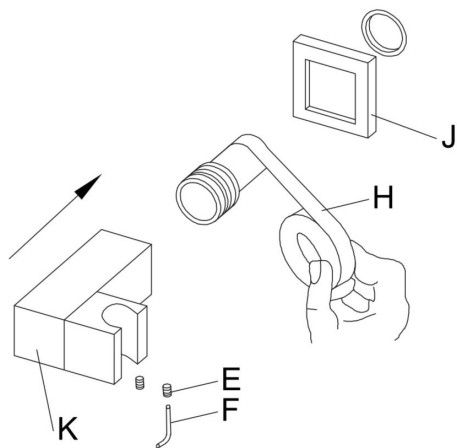

Uso del producto

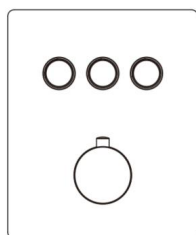

Key switch

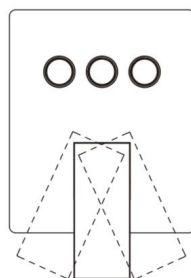

Key switch

Rotating temperature control

Rotating temperature control

CLEANING

9. Para mantener las condiciones de trabajo adecuadas se requiere limpieza

cuando hay depósitos minerales . Aparecen en las boquillas de pulverización.
Para limpiar los depósitos minerales o frotar suavemente las boquillas de goma en el cara de cabezal de la ducha para desalojarlo.

10. Para limpiar depósitos más pesados , retire el cabezal de la ducha y sumérgalo boca abajo en una taza de agua blanca. Vinagre durante 2-3 horas. Vuelva a colocar el cabezal de la ducha y ábralo en cada configuración de rociado para enjuagar. vinagre, NO utilice productos químicos agresivos ni limpiadores fuertes ni abrasivos. Esto puede dañar piezas o el producto terminado y puede anular la garantía.

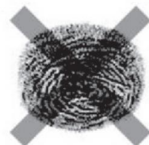

Fabricante: Shanghaimuxinmuyeyouxiangongsi

Dirección: Shuangchenglu 803nong11hao1602A-1609shi, baoshanqu, Shanghái 200000 CN.

Importado a AUS: SIHAO PTY LTD. 1 ROKEVA STREET, EASTWOOD NSW 2122 Australia

Importado a EE. UU.: Sanven Technology Ltd. Suite 250, 9166 Anaheim Lugar, Rancho Cucamonga, CA 91730

UK	REP
-----------	------------

YH CONSULTING LIMITED. C/O YH Consulting
Limited Office 147, Centurion House, London
Road, Staines-upon-Thames, Surrey, TW18 4AX

EC	REP
-----------	------------

E-CrossStu GmbH
Mainzer Landstr.69,
60329 Frankfurt am Main.



VEVOR

Affordable. Reliable. Home Improvement.

WIELE GŁOWIC PRYSZNICOWYCH

MODEL: FS10282-BN, FS10282-BN-G, FS10282-MB, FS10282-MB-G,
FS10281-CP, FS10281-CP-G, FS10281-BG, FS10281-BG-G,
FS10281-MB, FS10281-MB-G ,
FS10280-BN, FS10280-BN-G, FS10280-MB, FS10280-MB-G,
FS10283-CP, FS10283-CP-G

VEVOR

Affordable. Reliable. Home Improvement.

MULTIPLE SHOWER HEADS

FS10280-BN , FS10280-BN-G
FS10280-MB , FS10280-MB-G

FS10281-CP , FS10281-CP-G
FS10281-BG , FS10281-BG-G
FS10281-MB , FS10281-MB-G

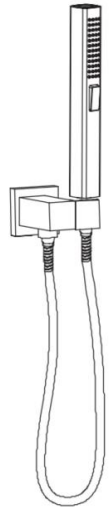
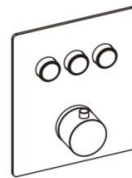
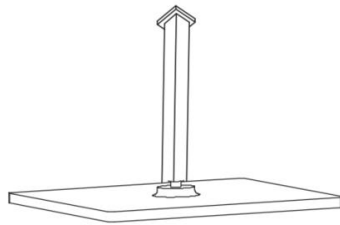
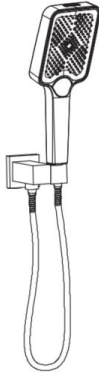
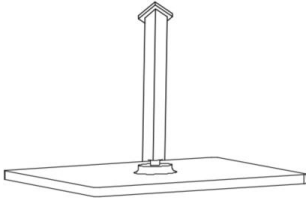

**FS10282-BN, FS10282-BN-G
FS10282-MB, FS10282-MB-G**

FS10283-CP, FS10283-CP-G

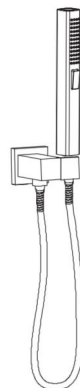
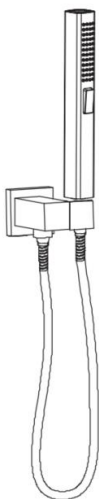
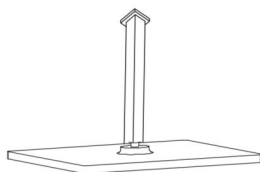
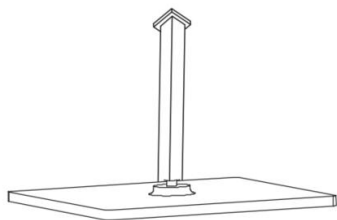

To jest oryginalna instrukcja obsługi. Przed użyciem prosimy o dokładne zapoznanie się z treścią instrukcji. Firma VEVOR zastrzega sobie prawo do jednoznacznej interpretacji niniejszej instrukcji obsługi. Wygląd produktu zależy od stanu, w jakim go otrzymali Państwo. Prosimy o wyrozumiałość, ale nie będziemy Państwa ponownie informować o



Ostrzeżenie: Aby zminimalizować ryzyko obrażeń, użytkownik powinien uważnie przeczytać instrukcję obsługi.

aktualizacjach technologicznych lub oprogramowania naszego produktu.

INSTRUCTIONS

Wskazówki ostrzegawcze :

41. Podczas montażu najlepiej jest założyć rękawice, aby zapobiec porysowaniu dłoni ostrymi krawędziami panelu.
42. Podczas montażu prysznicza należy upewnić się, że wszystkie połączenia są dokładnie dokręcone, aby uniknąć wycieku wody.
43. Jeżeli nie używasz prysznicza, zamknij zawór przełączający prysznicza.
44. Nie ponosimy odpowiedzialności za żadne z następujących roszczeń : 1. Uszkodzenia i/lub awarie spowodowane niewłaściwym użytkowaniem i/lub konserwacją; lub nieautoryzowaną przebudową; w tym uszkodzenia spowodowane nadużyciem (np. upadki, krople, itp.) 2. Zatrudnij profesjonalnego hydraulika. Nie ponosimy odpowiedzialności za jakiegokolwiek uszkodzenia i/lub awarie spowodowane nieprawidłową instalacją. 3. Uszkodzenia i/lub awarie spowodowane demontażem po instalacji lub innymi czynnikami.
45. Uszkodzenia i/lub awarie spowodowane przez aplikacje wykraczające poza zakres użytkowania.
46. Uszkodzenia i/lub awarie spowodowane przez piasek, pył i inne zanieczyszczenia
47. Uszkodzenia i/lub awarie spowodowane niewłaściwą/niedostateczną konserwacją; rdza na powierzchni itp.
48. Uszkodzenia i/lub awarie spowodowane przez pożar, trzęsienie ziemi, powódź, uderzenie pioruna i inne klęski żywiołowe, zanieczyszczenie, szkodliwy gaz, sól, nieprawidłowe napięcie i inne czynniki.

Środki ostrożności podczas instalacji.

1. Przed montażem szpuli należy oczyścić rurę z brudnej wody, osadów, piasku i zanieczyszczeń. Nie otwierać osłony ochronnej przed montażem szpuli, aby uniknąć zanieczyszczeń.
2. Krany oraz rury ciepłej i zimnej wody muszą być prawidłowo zamontowane. Stojąc twarzą do kranu, podłącz ciepłą wodę po lewej stronie, a zimną po prawej.
3. Sprawdź rozmiar instalacji. Nie instaluj produktu na siłę, aby uniknąć uszkodzenia części. Jak czyścić głowicę prysznicową: Aby zachować jasność zewnętrzną i dobrą wydajność prysznicza, należy dbać o niego w następujący

sposób:

p. Spłukać wyłącznie wodą i osuszyć miękką bawełnianą ściereczką.

q. Umieść głowicę prysznica w garnku i napełnij go octem w ilości wystarczającej, aby ją przykryć. Kwas zawarty w occie pomaga rozpuścić osady na białej dyszy. Pozostaw głowicę prysznica w occie na 30 minut. Im bardziej brudna głowica, tym dłużej trzeba będzie ją moczyć w occie.

r. Do usuwania brudu i osadu z powierzchni można używać łagodnego, bezbarwnego środka do czyszczenia szkła, nie jest to jednak środek ścierny 4. Nie należy używać detergentów kwaśnych, nierozpuszczalnych detergentów w granulach, mydła itp.

ZACHOWAJ TE INSTRUKCJE

INSTALLATION INSTRUCTIONS

Model	FS10280	FS10281	FS10282	FS10283
Zawór sterujący	Typowa temperatura	Stała temperatura	Typowa temperatura	Typowa temperatura
Głowa Prysznic	12 cali	12 cali	10 cali	10 cali
Głowa Prysznic	Kwadrat	Pas	Pas	Pas
Prysznic Arm 's	6 cali	6 cali	6 cali	Nieważny
Prysznic z tyłu	Nieważny	Nieważny	Nieważny	2 cale
Opis natężenia przepływu	2,2 GPM (8,3 l / min)			
Gwinty rurowe	Zero= NPT1/2" -G= G1/2"			
Kolor	-B N=Szczotkowany nikiel, -M B= Matowa czerń , -B G=Szczotkowane złoto, -C P=Chromowanie,			

PARTS LIST

Narzędzia, których możesz potrzebować



Wrench



Screwdriver



Teflon Tape

Zainstaluj akcesoria

Klucz imbusowy (1 szt.)



Taśma
teflonowa
(1 szt.)



Śruby
(4 szt.)



Śruba
(4 szt.)



Płaski
(4 szt.)



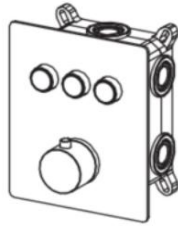

FS10281

Parts included

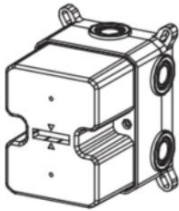

① Faucet Body

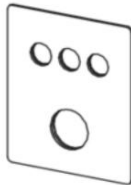

② Panel



③ Showerhead



④ Shower arm



⑤ Showerhead

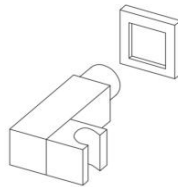

⑥ Shower Socket



⑦ Shower Hose



⑧ Showerhead

+



⑨ Shower arm

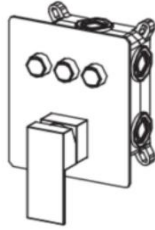

FS10280
FS10282
FS10283

Parts included

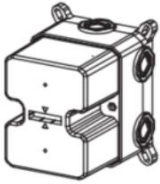

① Faucet Body

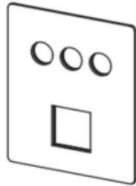

② Panel



③ Handle



④ Showerhead



⑤ Shower arm

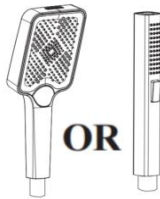

⑥ Showerhead

OR



⑦ Shower Socket

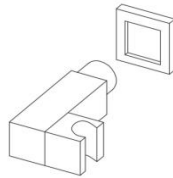

⑧ Shower Hose

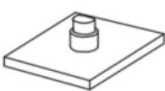

⑨ Showerhead

+

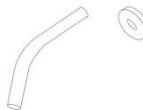

⑩ Shower arm

OR

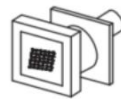

⑨ Back Spray*6

INSTALLATION STEPS

Sugerowane wymiary instalacji

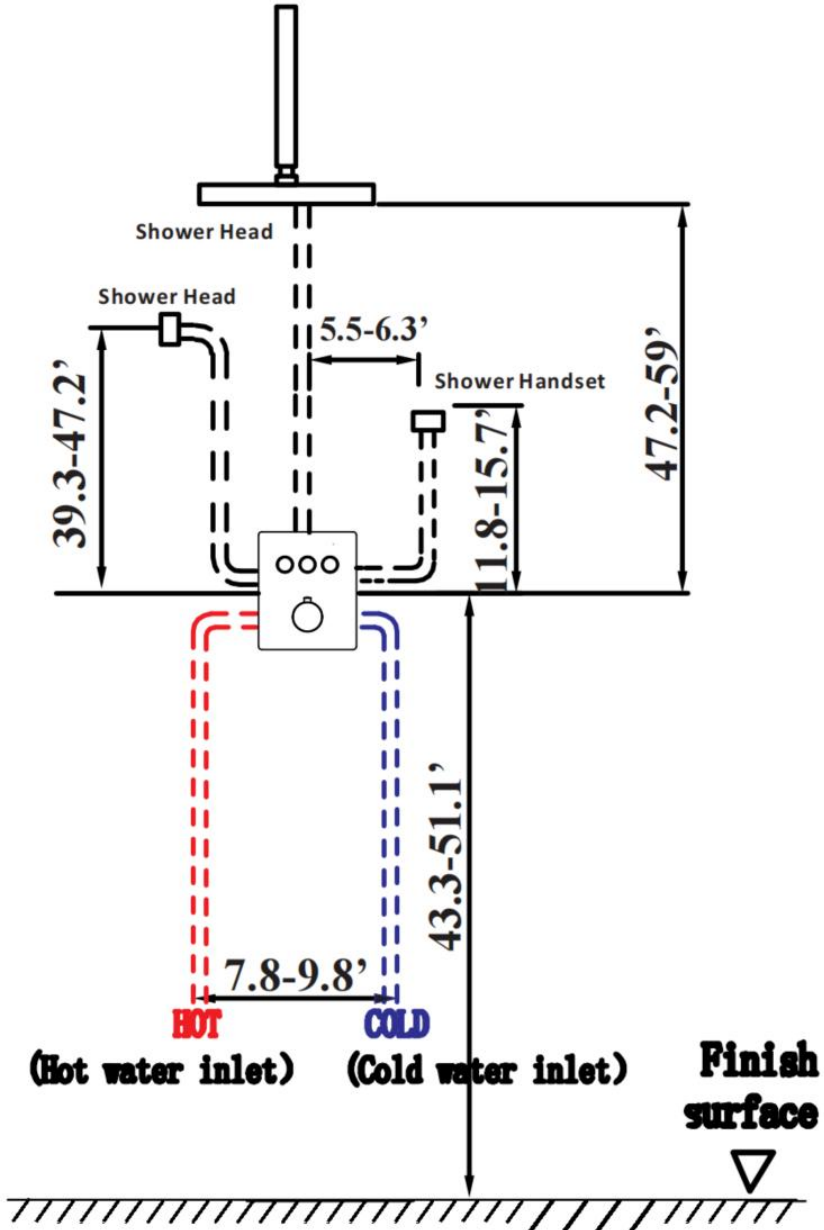

31. Zgodnie z warunkami na miejscu i wymagania dotyczące rozmiaru instalacji a żeby zrobić otwór, rozmiar otworu wynosi 7 cali (długość)* 5,5 cala (szerokość) *2,75-3,15 cala (głęboko)

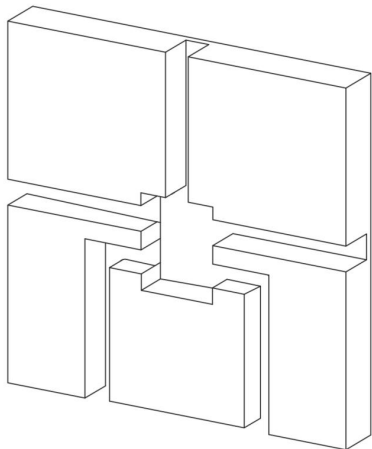

32. Zgodnie z warunkami na miejscu i instalacją wymagania dotyczące rozmiaru potrzebnego do ułożenia rurociągu. (2). Podłącz plastikowe pudełko do rury, umieść plastikowe pudełko na otwór, następnie dostosuj poziomy (bąbelek na środku) wyrównywacza).(3). Wykonaj otwory pozycjonujące.

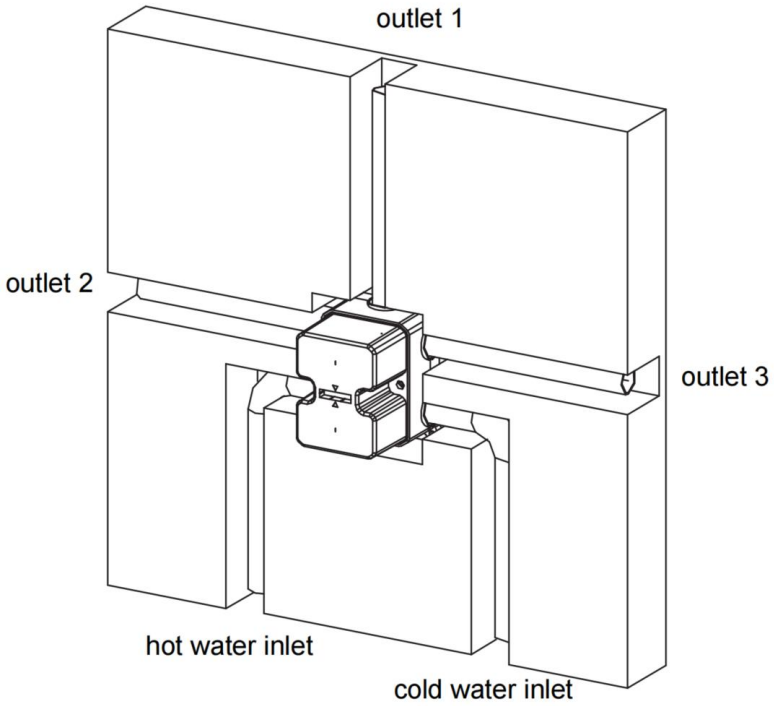
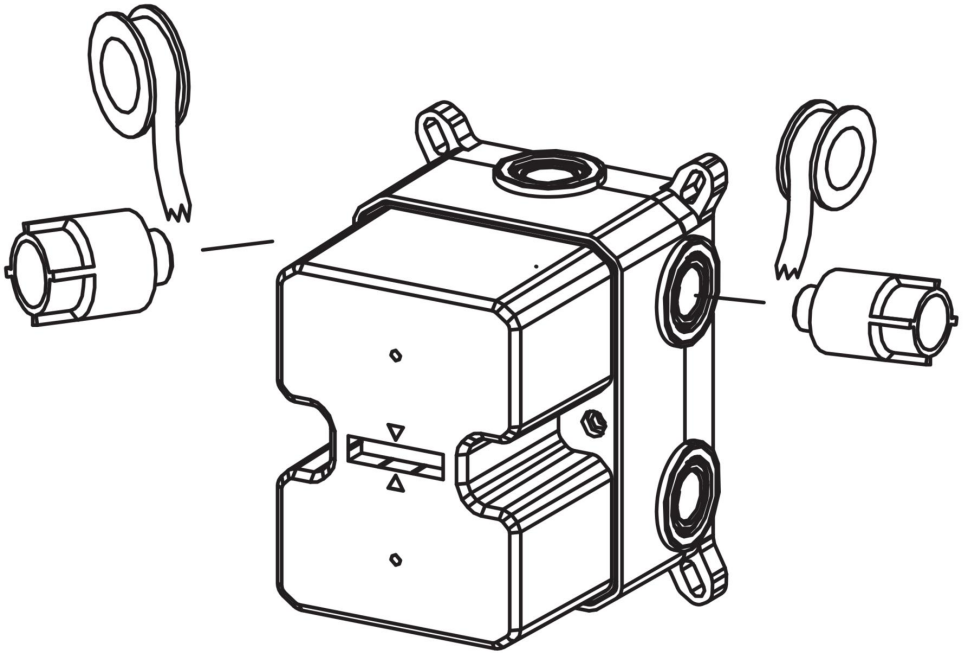

33. Po zakończeniu prac nad ścianą zdejmij osłonę ochronną i zamontuj Przymocuj rozetę (B) do zaworu (A) i dociśnij ją do wykończonej ściany. Następnie zamontuj klamkę (C), dokręć śruby ustalające (E) kluczem imbusowym (F) i załóż przyciski sygnalizacyjne (G).

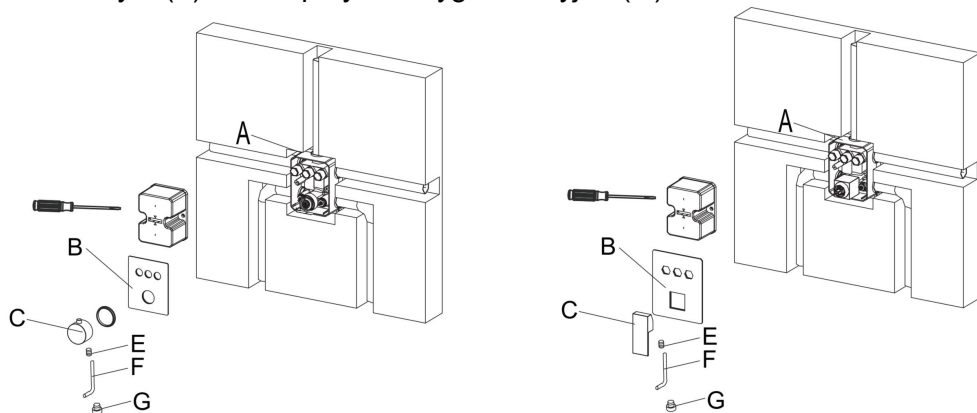

34. Włącz wodę na 1 minutę, aby wypłukać wszelkie zanieczyszczenia. Przyklej taśmę teflonową (H) rurę wylotową z gwintem i zamontuj wąż prysznicowy (I) do wylotu w ścianie. Następnie podłącz górny prysznic (P) do wylewki .

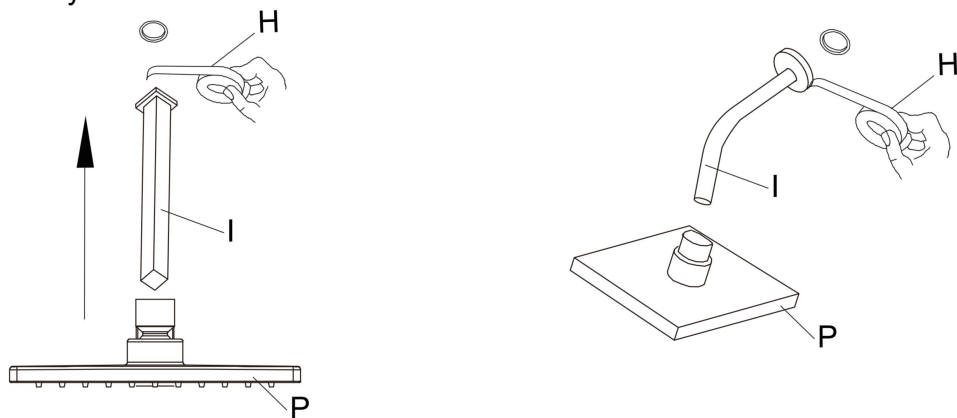

35. Nałóż taśmę teflonową (H) na gwintowany koniec i zamocuj zamontuj płytkę osłonową (d) na uchwycie

36. Odległość między dno otworu i powierzchnia płytki wynosi 30mm. Przekręć dyszę do rura osadzona w

ściennym (K) i przykręć uchwyt ścienny (K) do wyjścia słuchawki prysznicowej i przykręć (E) kluczem imbusowym (F).

ścianie;

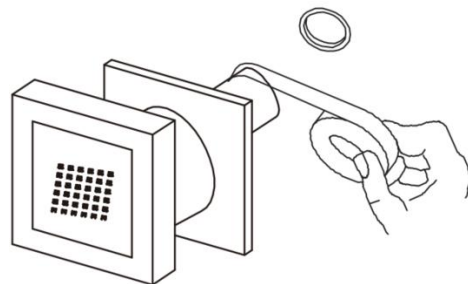
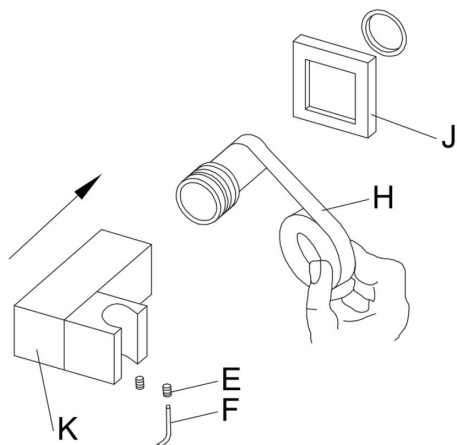

Zastosowanie produktu

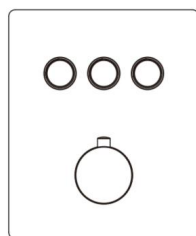

Key switch

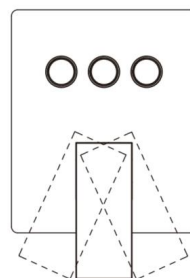

Key switch

Rotating temperature control

Rotating temperature control

CLEANING

11. Aby utrzymać odpowiednie warunki pracy lub w przypadku osadów mineralnych konieczne jest czyszczenie pojawiają się na dyszach spryskiwaczy. Aby oczyścić osady mineralne lub delikatnie przetrzeć gumowe dysze twarz

głowica prysznicowa do wyjęcia.

12. Aby usunąć większe osady / zdejmij głowicę prysznica i zanurz twarz w kubku z białą wodą Ocet przez 2-3 godziny. Załóż głowicę prysznica i ustaw każdy tryb strumienia, aby wypłukać. Ocet, NIE UŻYWAJ agresywnych środków chemicznych / silnych środków czyszczących ani materiałów ściernych. Może to uszkodzić części lub gotowy produkt i spowodować unieważnienie gwarancji.



Producent: Shanghaimuxinmuyeyouxiangongsi

Adres: Shuangchenglu 803nong11hao1602A-1609shi, baoshanqu, szanghaj 200000 CN.

Importowane do AUS: SIHAO PTY LTD. 1 ROKEVA STREETEASTWOOD NSW 2122 Australia

Importowane do USA: Sanven Technology Ltd. Suite 250, 9166 Anaheim Miejsce, Rancho Cucamonga, CA 91730

UK	REP
-----------	------------

YH CONSULTING LIMITED. C/O YH Consulting
Limited Office 147, Centurion House, London
Road, Staines-upon-Thames, Surrey, TW18 4AX

EC	REP
-----------	------------

E-CrossStu GmbH
Mainzer Landstr.69,
60329 Frankfurt am Main.



VEVOR

Affordable. Reliable. Home Improvement.

MEERDERE DOUCHEKOPPEN

MODEL: FS10282-BN, FS10282-BN-G, FS10282-MB, FS10282-MB-G,
FS10281-CP, FS10281-CP-G, FS10281-BG, FS10281-BG-G,
FS10281-MB, FS10281-MB-G ,
FS10280-BN, FS10280-BN-G, FS10280-MB, FS10280-MB-G,
FS10283-CP, FS10283-CP-G

VEVOR

Affordable. Reliable. Home Improvement.

MULTIPLE SHOWER HEADS

FS10280-BN , FS10280-BN-G
FS10280-MB , FS10280-MB-G

FS10281-CP , FS10281-CP-G
FS10281-BG , FS10281-BG-G
FS10281-MB , FS10281-MB-G

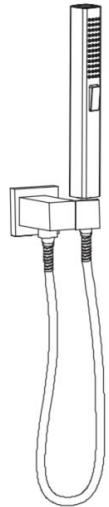
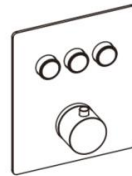
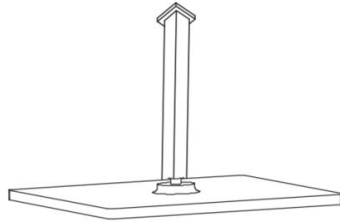
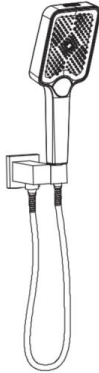
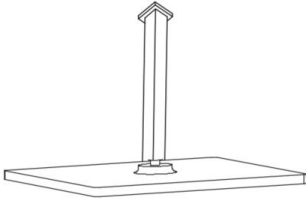

**FS10282-BN, FS10282-BN-G
FS10282-MB, FS10282-MB-G**

FS10283-CP, FS10283-CP-G

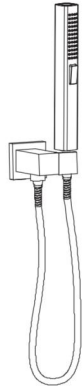
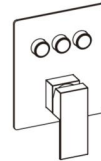
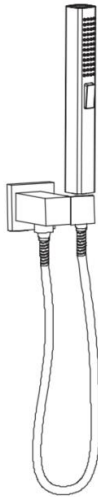
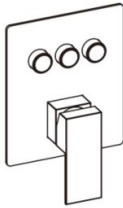
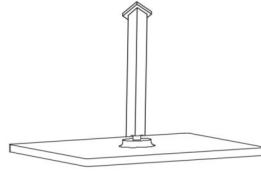
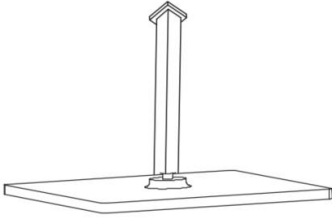

Dit is de originele handleiding. Lees alle instructies zorgvuldig door voordat u het product gebruikt. VEVOR behoudt zich het recht voor om de gebruiksaanwijzing duidelijk te interpreteren. Het uiterlijk van het product is afhankelijk van het product dat u hebt ontvangen. Neemt u het ons niet kwalijk dat we u niet meer op de hoogte stellen van eventuele



Waarschuwing: om het risico op letsel te verminderen, moet de gebruiker de gebruiksaanwijzing zorgvuldig lezen.

technologische of software-updates voor ons product.

INSTRUCTIONS

Waarschuwingstips :

49. Tijdens de installatie is het raadzaam om handschoenen te dragen om te voorkomen dat scherpe hoeken van het paneel uw handpalm beschadigen.
50. Zorg er bij het installeren van de douche voor dat alle verbindingen goed vastgedraaid zijn om waterlekage te voorkomen.
51. Wanneer u de douche niet gebruikt, sluit u de hoofdkraan van de douche.
52. Niet aansprakelijk zijn voor de volgende claims : 1. Schade en/of defecten veroorzaakt door onjuist gebruik en/of onderhoud; of elke ongeoorloofde herbouw; inclusief schade veroorzaakt door misbruik (bijv. vallen, laten vallen, etc.) 2. Schakel een professionele loodgieter in. Wij zijn niet verantwoordelijk voor schade en/of storingen veroorzaakt door een onjuiste installatie. 3. Schade en/of defecten veroorzaakt door verwijdering na installatie of andere factoren.
53. Schade en/of storingen veroorzaakt door toepassingen die buiten het gebruiksbereik vallen.
54. Schade en/of defecten veroorzaakt door zand, stof en andere onzuiverheden
55. Schade en/of defecten veroorzaakt door onjuist/onvoldoende onderhoud; roestbehandeling van het oppervlak, etc.
56. Schade en/of defecten veroorzaakt door brand, aardbevingen, overstromingen, bliksem en andere natuurrampen, vervuiling, schadelijk gas, zout, abnormale spanning en andere factoren.

Voorzorgsmaatregelen bij de installatie.

1. Verwijder vóór het installeren van de spoel het vuile water, resten, zand en andere onzuiverheden uit de leiding. Open de beschermkap niet voordat u de spoel installeert om onzuiverheden te voorkomen.
2. Kranen en warm- en koudwaterleidingen moeten correct worden geïnstalleerd. Sluit, tegenover de kraan, warm water aan de linkerkant en koud water aan de rechterkant aan.
3. Controleer de installatiemaat. Forceer de installatie van het product niet om beschadiging van de onderdelen te voorkomen. Hoe een douchekop te reinigen: Om de helderheid van de buitenkant en de goede prestaties van de douche te behouden, dient u de douche op de volgende manieren te onderhouden:

- s. Alleen afspoelen met water en drogen met een zachte katoenen doek.
- t. Plaats de douchekop in een pan en vul de pan met zoveel witte azijn dat de douchekop helemaal onder staat. Het zuur in de azijn helpt de afzettingen op de witte mineraalproeikop op te lossen. Laat de douchekop 30 minuten in azijn weken. Hoe vuiler de douchekop, hoe langer je hem in azijn moet laten weken.
- u. Voor het verwijderen van oppervlaktevuil en vuilfilm kan een milde vloeibare en kleurloze glasreiniger worden gebruikt, geen schurend polijstmiddel 4. Gebruik geen zure reinigingsmiddelen, onoplosbare korrelvormige reinigingsmiddelen, zeep, enz.

BEWAAR DEZE INSTRUCTIES

INSTALLATION INSTRUCTIONS

Model	FS10280	FS10281	FS10282	FS10283
Regelklep	Gewone temperatuur	Constante temperatuur	Gewone temperatuur	Gewone temperatuur
Hoofd Douche	12 inch	12 inch	10 inch	10 inch
Hoofd Douche	Vierkant	Strip	Strip	Strip
Arm 's Douche	6 inch	6 inch	6 inch	Nul
Terug ' s Douche	Nul	Nul	Nul	2 inch
Beschrijving van de stroomsnelheid	2,2 GPM (8,3 L / min)			
Pijpdraden	Nul = NPT1/2" -G = G1/2"			
Kleur	-B N = Geborsteld nikkel, -M B = Matzwart , -B G=Geborsteld goud, -C P=Chroomplating,			

PARTS LIST

Gereedschappen die u mogelijk nodig heeft



Wrench







Screwdriver



Teflon Tape

Accessoires installeren

Inbussleutel (1 stuk)	Teflontape (1 stuk)	Schroeven (4 stuks)	Bout (4 stuks)	Vlak (4 stuks)
				

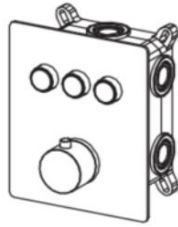

FS10281

Parts included

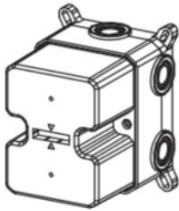

① Faucet Body

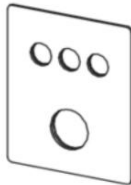

② Panel



③ Showerhead



④ Shower arm



⑤ Showerhead

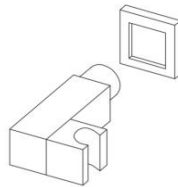

⑥ Shower Socket



⑦ Shower Hose

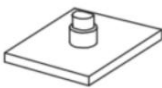

⑧ Showerhead

+



⑨ Shower arm

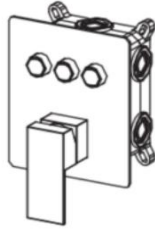

FS10280
FS10282
FS10283

Parts included

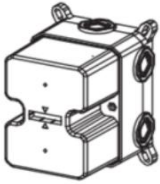

① Faucet Body

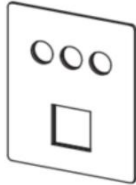

② Panel



③ Handle



④ Showerhead



⑤ Shower arm

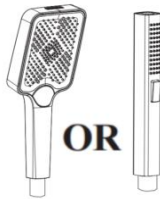

⑥ Showerhead

OR



⑦ Shower Socket

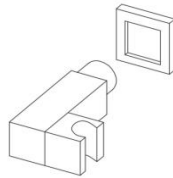

⑧ Shower Hose

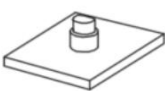

⑨ Showerhead

+

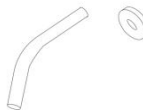

⑩ Shower arm

OR

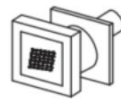

⑨ Back Spray*6

INSTALLATION STEPS

Stel installatieafmetingen voor

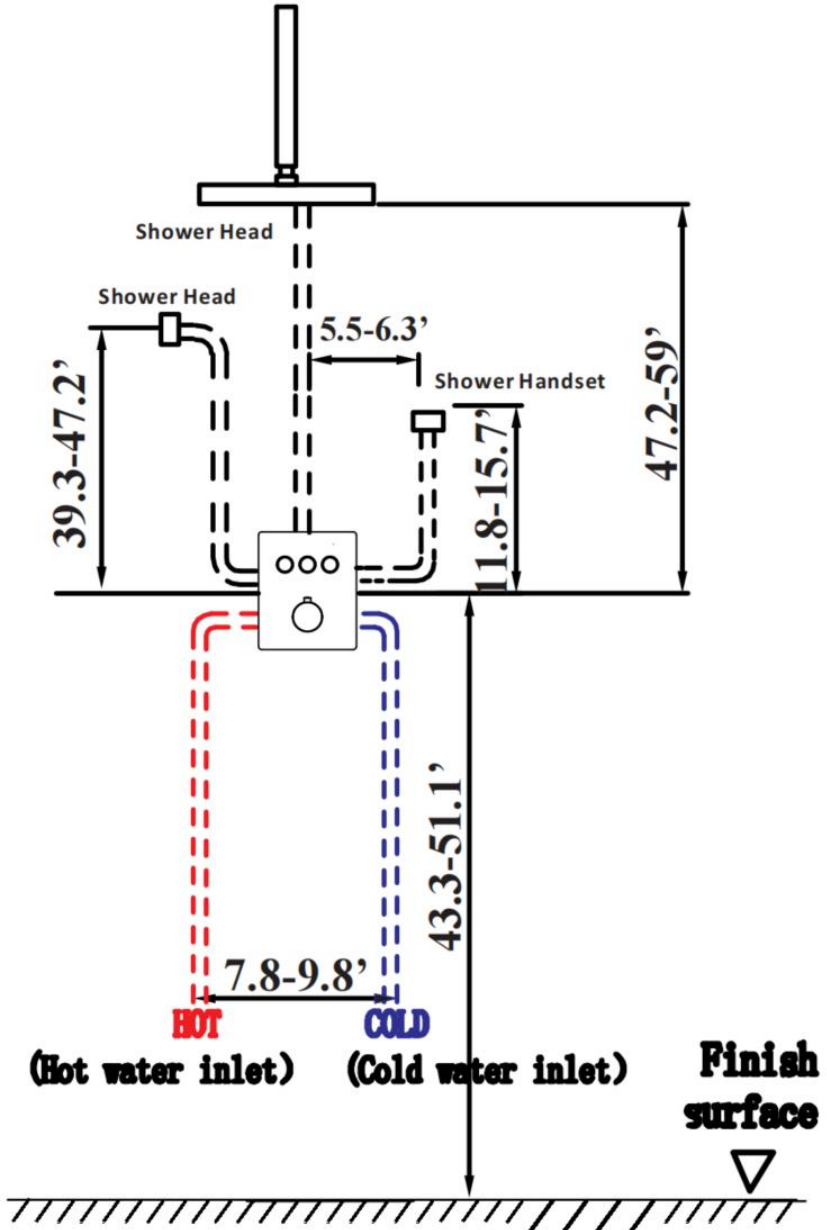

37. Volgens de omstandigheden ter plaatse en de vereiste installatiegrootte en om een gat te maken, is de gatgrootte 7 inch (lengte)* 5,5 inch (breedte) *2,75-3,15 inch (diep)

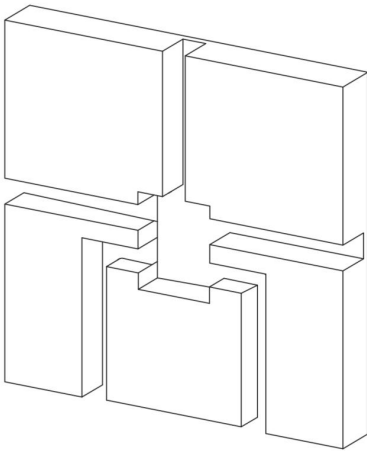

38. Afhankelijk van de omstandigheden ter plaatse en de installatie Groottevereisten voor het opzetten van de pijpleiding. (2). Verbinden de plastic doos aan de pijp, plaats de plastic doos op de gat, Pas dan de niveaus aan (de bel in het midden) van de waterpas).(3). Maak de positioneringsgaten.

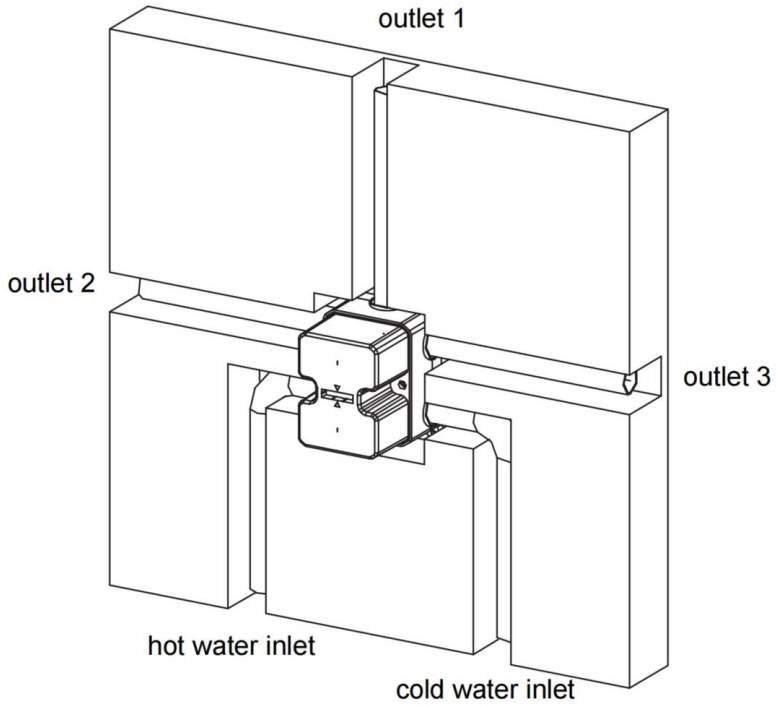
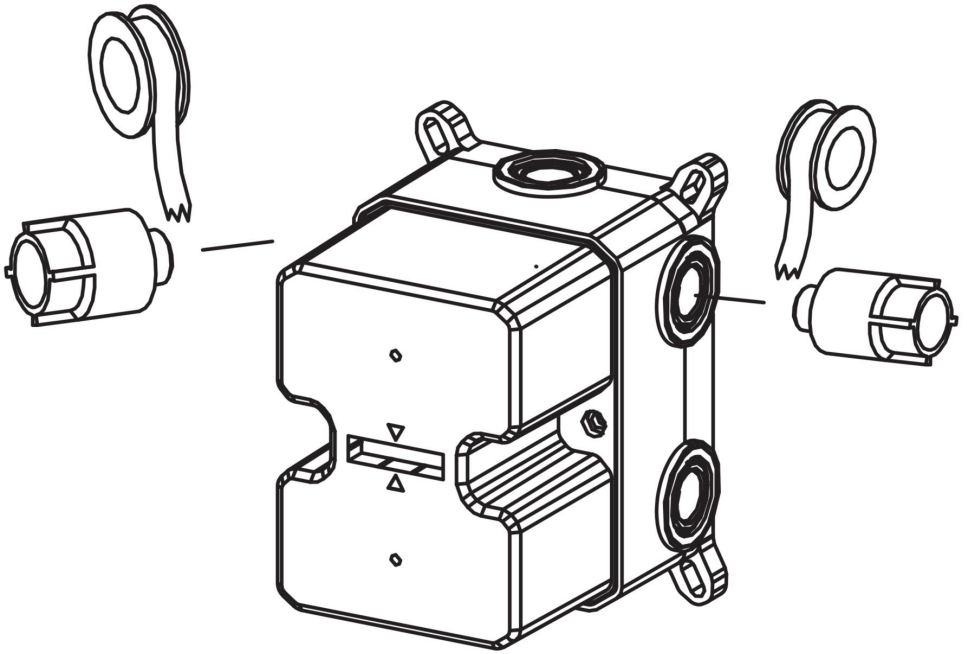

39. Verwijder de beschermkap wanneer de afgewerkte muur voltooid is en installeer de rozet (B) op de klep (A) en druk deze tegen de afgewerkte wand. Monteer vervolgens de hendel (C), draai de stelschroeven (E) vast met inbussleutel (F) en plaats de indicatielampjes (G).

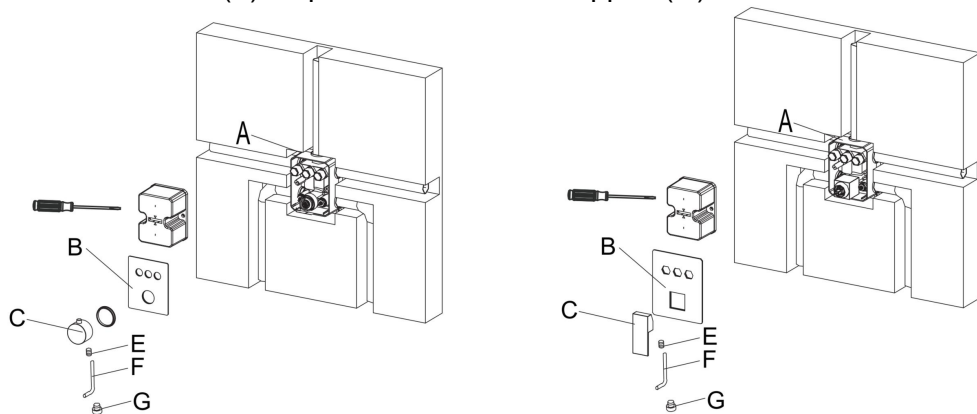

40. Zet het water 1 minuut aan om eventuele rommel weg te spoelen. Breng teflontape (H) aan de schroefdraad van de uitlaatpijp en installeer de doucheslang (I) in de uitlaat op de muur. Sluit vervolgens de bovenste douche (P) aan op de uitloop .

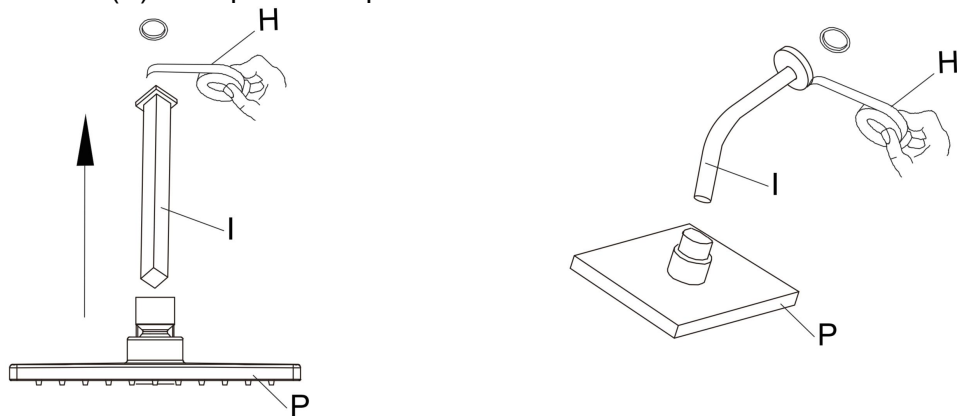

41. Breng teflontape (H) aan op het uiteinde met de schroefdraad en bevestig de afdekplaat (d) op de

42. De afstand tussen de onderkant van de opening en het oppervlak van de tegel is 30 mm. Draai het mondstuk

wandaansluithouder (K) en schroef de wandhouder (K) in de handdouche-uitlaat steken en (E) met inbussleutel (H) vastschroeven (F).

naar de ingebedde pijp in de muur;

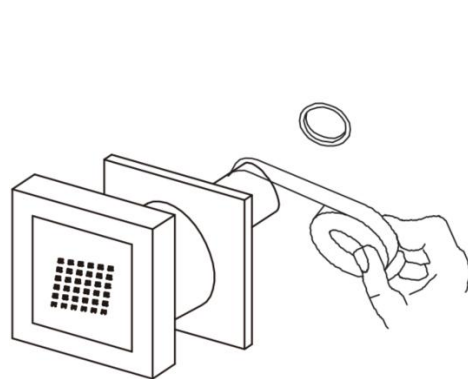
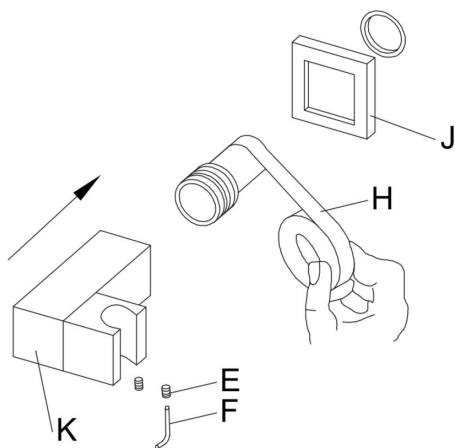

Productgebruik

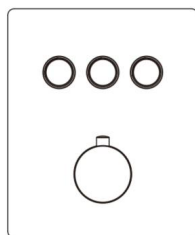

Key switch

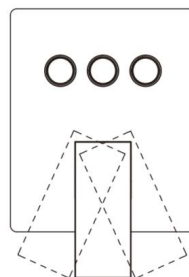

Key switch

Rotating temperature control

Rotating temperature control

CLEANING

13. Om de juiste werkomstandigheden te behouden of om reiniging te vereisen wanneer er minerale afzettingen zijn verschijnen op sproeikoppen. Om minerale

afzettingen te verwijderen of om zachtjes over de rubberen sproeikoppen te wrijven gezicht van douchekop losraken.

14. Om hardnekkige afzettingen te verwijderen / de douchekop verwijderen en met de voorkant naar beneden in een kopje witte zeep laten weken azijn gedurende 2-3 uur. Plaats de douchekop terug en laat hem op elke sproeistand draaien om door te spoelen. Gebruik GEEN agressieve chemicaliën / zware reinigingsmiddelen of schuurmiddelen. Dit kan onderdelen of het eindproduct beschadigen en de garantie ongeldig maken.



Fabrikant: Shanghaimuxinmuyeyouxiangongsi

Adres: Shuangchenglu 803nong11hao1602A-1609shi, baoshanqu, shanghai 200000 CN.

Geïmporteerd naar AUS: SIHAO PTY LTD. 1 ROKEVA STREETEASTWOOD

NSW 2122 Australië

Geïmporteerd naar de VS: Sanven Technology Ltd. Suite 250, 9166 Anaheim

Plaats, Rancho Cucamonga, CA 91730

UK	REP
-----------	------------

YH CONSULTING LIMITED. C/O YH Consulting
Limited Office 147, Centurion House, London
Road, Staines-upon-Thames, Surrey, TW18 4AX

EC	REP
-----------	------------

E-CrossStu GmbH
Mainzer Landstr.69,
60329 Frankfurt am Main.



VEVOR

Affordable. Reliable. Home Improvement.

FLERA DUSCHMUNSTYCKEN

MODELL: FS10282-BN, FS10282-BN-G, FS10282-MB, FS10282-MB-G,
FS10281-CP, FS10281-CP-G, FS10281-BG, FS10281-BG-G,
FS10281-MB, FS10281-MB-G ,
FS10280-BN, FS10280-BN-G, FS10280-MB, FS10280-MB-G,
FS10283-CP, FS10283-CP-G

VEVOR

Affordable. Reliable. Home Improvement.

MULTIPLE SHOWER HEADS

FS10280-BN , FS10280-BN-G
FS10280-MB , FS10280-MB-G

FS10281-CP , FS10281-CP-G
FS10281-BG , FS10281-BG-G
FS10281-MB , FS10281-MB-G

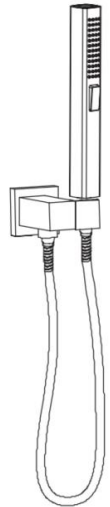
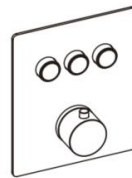
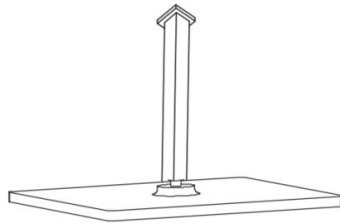
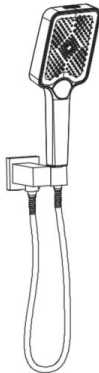
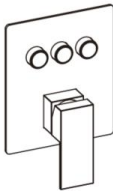
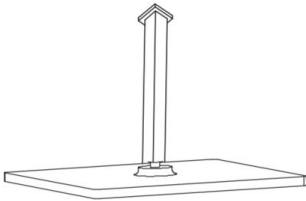

**FS10282-BN, FS10282-BN-G
FS10282-MB, FS10282-MB-G**

FS10283-CP, FS10283-CP-G

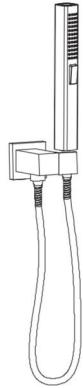
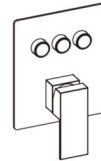
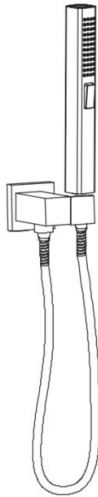
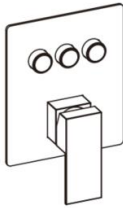
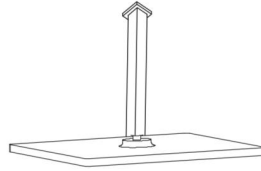
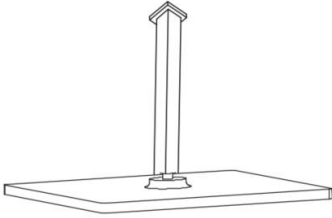

Detta är originalinstruktionerna, vänligen läs alla instruktioner noggrant innan du använder produkten. VEVOR förbehåller sig en tydlig tolkning av vår användarmanual. Produktens utseende ska vara beroende av den produkt du mottagit. Vi ber om ursäkt för att vi inte kommer att informera dig igen om det finns några teknik- eller programuppdateringar för vår



Varning – För att minska risken för skador måste användaren läsa instruktionsmanualen noggrant.

produkt.

INSTRUCTIONS

Varningstips :

57. Under installationsprocessen är det bäst att bära handskar för att förhindra att vassa hörn på panelen repar handflatan.
58. När du installerar duschen, se till att alla skarvar är ordentligt åtdragna för att undvika vattenläckage.
59. När duschen inte används, stäng duschens omkopplingsventil.
60. Inte ansvarig för något av följande anspråk : 1. Skador och/eller haverier orsakade av felaktig användning och/eller underhåll; Eller obehörig ombyggnad; inklusive skador orsakade av missbruk (t.ex. fall, dropp etc.) 2. Anlita en professionell rörmokare. Vi ansvarar inte för skador och/eller fel orsakade av felaktig installation. 3. Skador och/eller fel orsakade av borttagning efter installation eller andra faktorer.
61. Skador och/eller fel orsakade av tillämpningar utanför användningsområdet.
62. Skador och/eller fel orsakade av sand, damm och andra föroreningar
63. Skador och/eller fel orsakade av felaktigt/otillräckligt underhåll; Rostbehandling av ytor etc.
64. Skador och/eller fel orsakade av brand, jordbävning, översvämning, blixtnedslag och andra naturkatastrofer, föroreningar, skadlig gas, salt, onormal spänning och andra faktorer.

Installationsförsiktighetsåtgärder.

1. Innan du monterar spolen, rengör röret från smutsvatten, rester, sand och föroreningar. Öppna inte skyddskåpan innan du monterar spolen för att undvika föroreningar.
2. Kranar och varm- och kallvattenrör måste installeras korrekt. Vänd mot kranen, anslut varmvatten till vänster och kallvatten till höger.
3. Kontrollera installationsstorleken. Installera inte produkten med våld, annars kan delarna skadas. Så här rengör du ett duschmunstycke: För att bibehålla duschens ljusstyrka och goda prestanda, sköt om duschen på följande sätt:
 - v. Skölj endast med vatten och torka med en mjuk bomullstrasa.
 - w. Placera duschmunstycket i en kastrull och fyll kastrullen med tillräckligt med vitt vinäger för att täcka duschmunstycket. Syran i vinägern hjälper till att lösa upp

avlagringarna på det vita mineralmunstycket. Låt duschmunstycket ligga i blöt i vinäger i 30 minuter. Ju smutsigare duschmunstycket är, desto längre tid behöver du låta det ligga i blöt i vinäger.

x. Mild flytande och färglös glasrengöring kan användas för att ta bort ytsmuts och smutsfilm, inte slipande polermedel 4. Använd inte surt rengöringsmedel, olösligt granulärt rengöringsmedel, tvål etc.

SPARA DESSA INSTRUKTIONER

INSTALLATION INSTRUCTIONS

Modell	FS10280	FS10281	FS10282	FS10283
Kontrollventil	Vanlig temperatur	Konstant temperatur	Vanlig temperatur	Vanlig temperatur
Huvuden Dusch	12 tum	12 tum	10 tum	10 tum
Huvuden Dusch	Fyrkant	Remsa	Remsa	Remsa
Armdusch	6 tum	6 tum	6 tum	Noll
Tillbaka till duschen	Noll	Noll	Noll	2 tum
Flödes hastighet Beskrivning	2,2 GPM (8,3 L / min)			
Rörgångor	Noll= NPT1/2" -G= G1/2"			
Färg	-B N=Borstad nickel, -M B= Mattsvart , -B G=Borstad guld, -C P=Kromplätering,			

PARTS LIST

Verktyg du kan behöva



Wrench

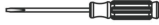





Screwdriver



Teflon Tape

Installera tillbehör

Sexkantsnyckel (1 st)	Teflontejp (1 st)	Skrubar (4 st)	Bult (4 st)	Platt (4 st)
				

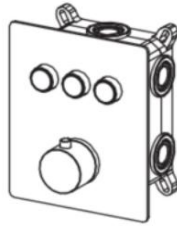

FS10281

Parts included

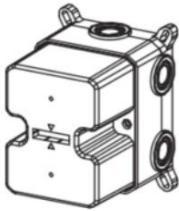

① Faucet Body

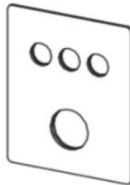

② Panel



③ Showerhead



④ Shower arm



⑤ Showerhead

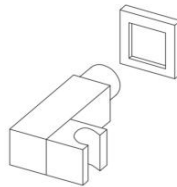

⑥ Shower Socket



⑦ Shower Hose

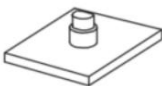

⑧ Showerhead

+



⑨ Shower arm

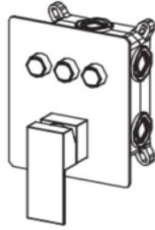

FS10280
FS10282
FS10283

Parts included

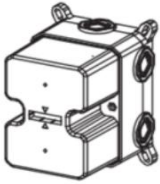

① Faucet Body

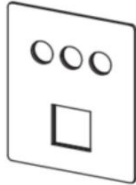

② Panel



③ Handle



④ Showerhead



⑤ Shower arm

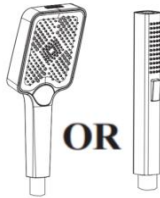

⑥ Showerhead



OR

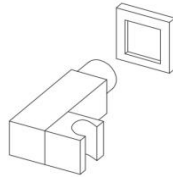

⑦ Shower Socket



⑧ Shower Hose

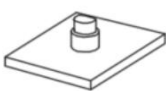

⑨ Showerhead

+

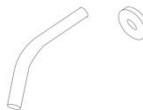

⑩ Shower arm

OR

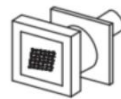

⑨ Back Spray*6

INSTALLATION STEPS

Föreslå installationsdimension

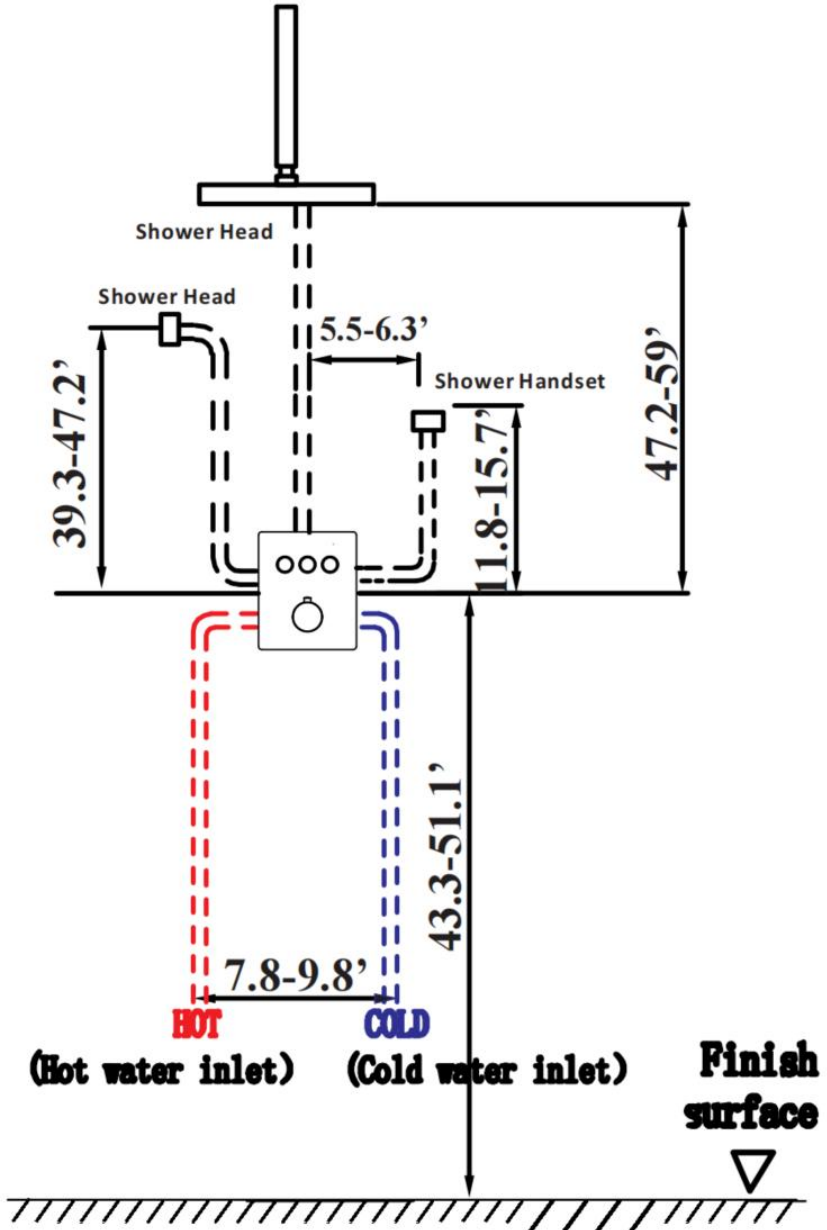

43. Enligt platsförhållandena och kravet på installationsstorlek och för att göra ett hål är hålstorleken 7 tum (längd)* 5,5 tum (bredd) *2,75–3,15 tum (djup)

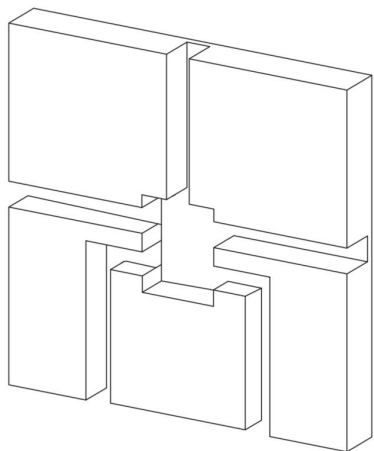

44. Enligt platsförhållandena och installationen storlekskrav för att installera rörledningen. (2). Anslut plastlådan till röret, placera plastlådan på hål, justera sedan bara nivåerna (bubblan i mitten) av nivåutjämnaren).(3). Gör positioneringshålen.

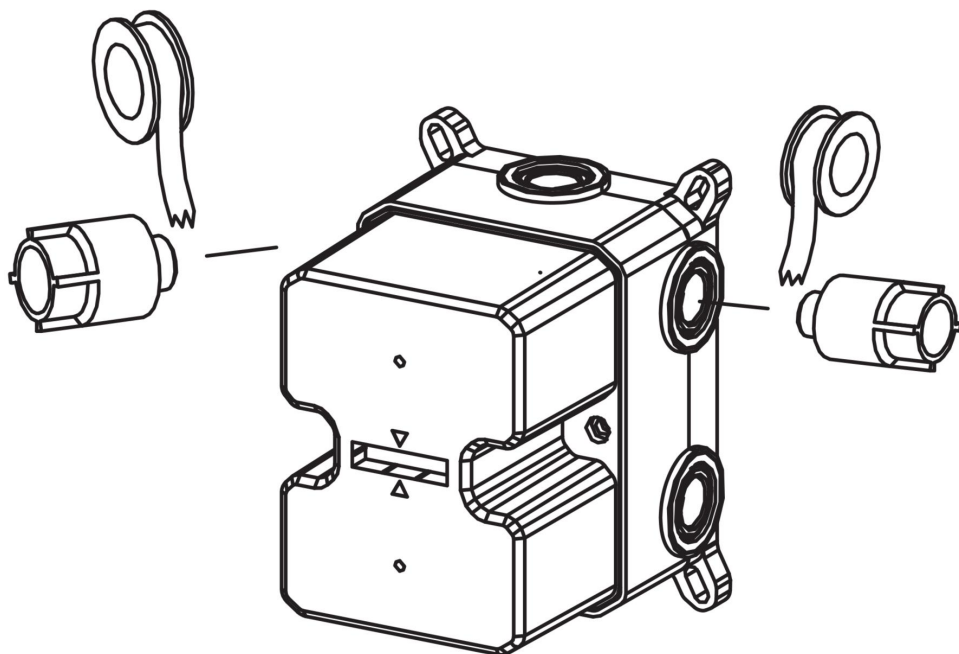

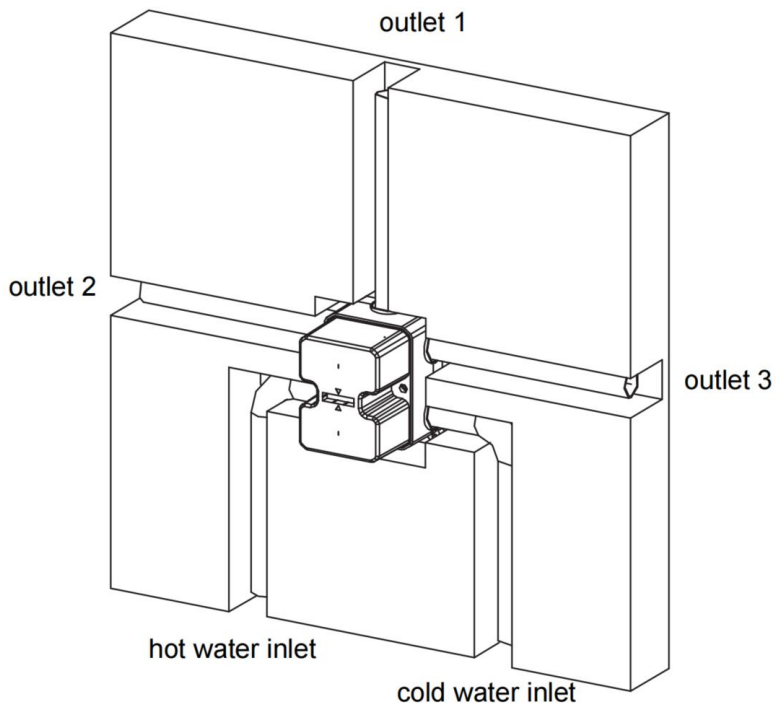

45. Ta bort skyddsloppet när den färdiga väggen är klar och montera Fäst täckbricka (B) på ventilen (A) och tryck den mot den färdiga väggen. Montera sedan handtaget (C), dra åt ställskruvarna (E) med insexnyckeln (F) och sätt på indikationsknappar (G).

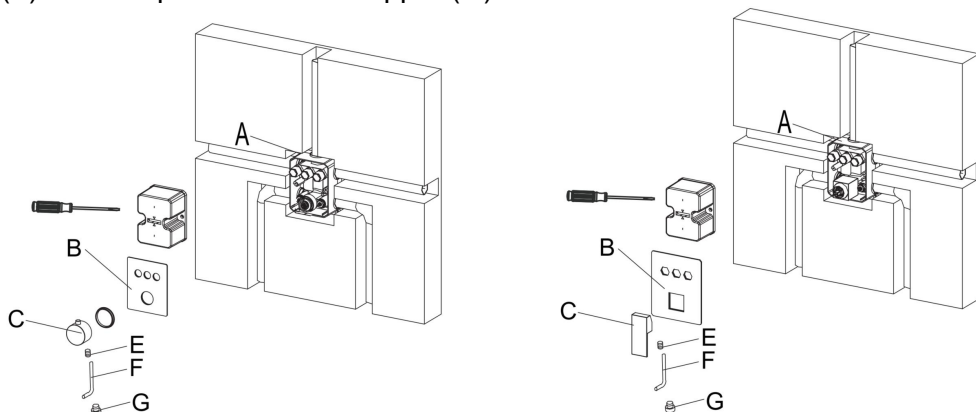

46. Sätt på vattnet i 1 minut för att spola bort eventuellt skräp. Sätt på teflontejp (H) på det gängade avloppsroret och montera duschslangen (I) i utloppet på väggen. Anslut sedan den övre duschen (P) till pipen .

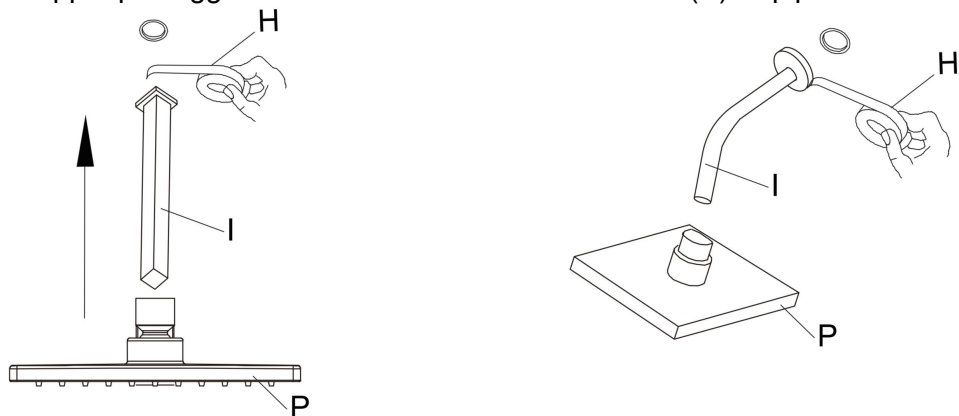

47. Applicera teflontejp (H) på den gängade änden, fixera sedan täckplattan (d) på vägguttagshållaren (K) och skruva fast den vägguttagshållaren (K) i handduschuttaget och skruva fast (E) med insexnyckel (F).

48. Avståndet mellan botten av öppningen och Kakelns yta är 30 mm. Vrid munstycket till rör inbäddat i väggen;

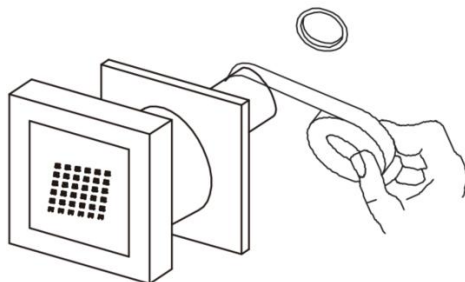
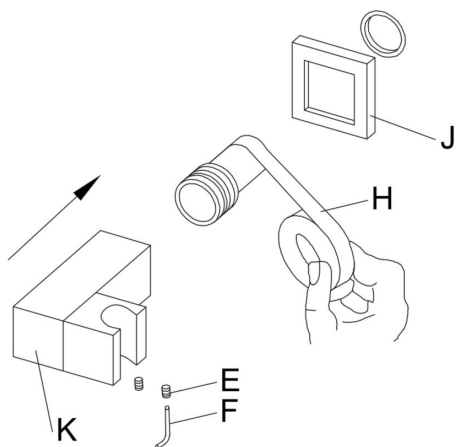

Produktanvändning

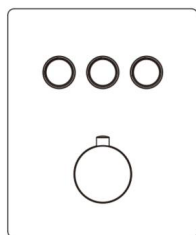

Key switch

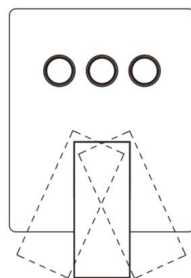

Key switch

Rotating temperature control

Rotating temperature control

CLEANING

15. För att upprätthålla goda arbetsförhållanden krävs rengöring vid mineralavlagringar . syns på sprutmunstyckena. För att rengöra mineralavlagringar eller försiktigt gnugga gummimunstyckena på ansiktet av duschmunstycket att lossna.

16. För att rengöra tyngre avlagringar / ta bort duschmunstycket och blötlägg med ansiktet nedåt i en kopp vitt vatten vinäger i 2–3 timmar. Sätt tillbaka duschmunstycket och spola med varje strålenivå. vinäger, ANVÄND INTE starka kemikalier / tunga rengöringsmedel eller slipmedel. Detta kan skada delar eller färdig produkt och kan upphäva garantin.



Tillverkare: Shanghaimuxinmuyeyouxiangongsi

Address: Shuangchenglu 803nong11hao1602A-1609shi, baoshanqu, Shanghai 200 000 kanadensiska republiken.

Importerad till Australien: SIHAO PTY LTD. 1 ROKEVA STREETEASTWOOD

NSW 2122 Australien

Importerad till USA: Sanven Technology Ltd. Suite 250, 9166 Anaheim Plats, Rancho Cucamonga, Kalifornien 91730

UK	REP
-----------	------------

YH CONSULTING LIMITED. C/O YH Consulting Limited Office 147, Centurion House, London Road, Staines-upon-Thames, Surrey, TW18 4AX

EC	REP
-----------	------------

E-CrossStu GmbH
Mainzer Landstr.69,
60329 Frankfurt am Main.

