

VEVOR

Affordable. Reliable. Home Improvement.

SNOWBOARD ROOF RACK

MODEL: RN-2101

VEVOR

Affordable. Reliable. Home Improvement.

SNOWBOARD ROOF RACK

MODEL : RN-2101

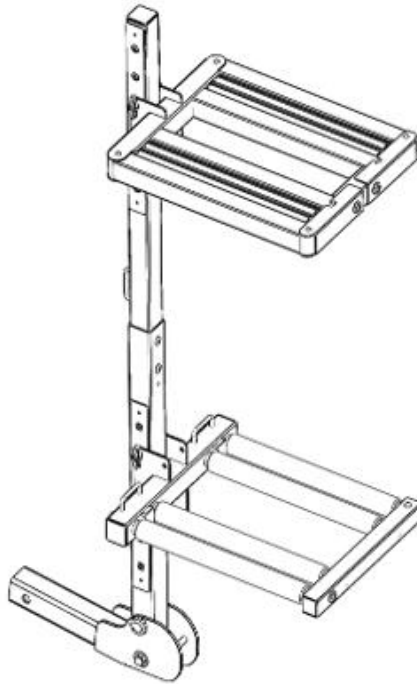

This is the original instruction, please read all manual instructions carefully before operating. VEVOR reserves a clear interpretation of our user manual. The appearance of the product shall be subject to the product you received. Please forgive us that we won't inform you again if there are any technology or software updates on our product.



Warning-To reduce the risk of injury, user must read instructions manual carefully.

WARNING:

PLEASE READ AND UNDERSTAND ALL SAFETY RULES BEFORE ASSEMBLY AND USE OF THE SNOWBOARD ROOF RACK.

RULES FOR SAFE OPERATION:

1. Do not carry more than six pairs of skis or more than four snowboard on the carrier.
2. The ski / snowboard carrier raises the overall height of the vehicle. Pay attention to overhead obstacles when driving with the ski / snowboard carrier.
3. Before and after driving, or after loading skis or a snowboard on the carrier, check the security of the carrier mounts and retighten them as necessary.
4. Install the ski / snowboard carrier after installing the crossbars on the roof.
5. Do not damage the roof and other finished surfaces of the body when installing the ski/ snowboard carrier.
6. Notice the ski / snowboard before opening the tailgate or hatchback.
7. Remove the ski / snowboard carriers before entering automatic car washes.
8. The weight of the cargo must not exceed the maximum weight limit of 165 lbs (75kg).
9. Check the mounting bolts before use every time and drive under 120km/h (75mph) for security.

PRECAUTION



1. Avoid sudden starts or stops with the carrier on the vehicle. It may cause fasteners to loosen.
2. Obey local laws and regulations.
3. Before driving, check that the carrier is locked securely regardless of whether or not skis or a snowboard are mounted on the carrier.
4. Do not use the ski / snowboard carrier to carry goods other than ski and snowboard.







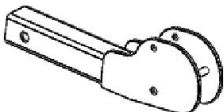

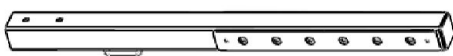
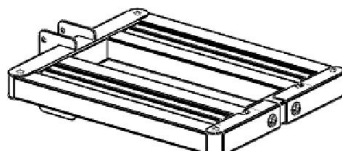
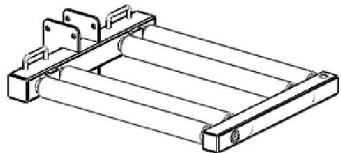

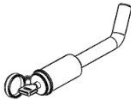



Save the instructions

SPECIFICATIONS

Model	RN-2101
Material	Steel
Color	Black
Load Capacity	6 Pr Skis / 4 Snowboards
Loading Width	400mm * 2
Hitch Receiver	2"
Max Weight	165 lbs (75kg)

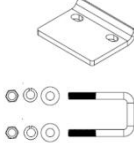
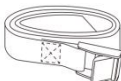
PACKAGE CONTENTS

Part	Description	picture	QTY
1	Hitch Bar		1
2	Bottom Post		1
3	Top Post		1
4	Top Rack		1
5	Bottom Rack		1

6	Hitch Lock		1
7	M10*80 Quick Bolt		1
8	M10 Lock Nut		1
9	M12*80 Hex Bolt		1
10	M12 Washer		2
11	M12 Nut		1
12	T Style M8*80 Bolts		4
13	M8 Plum Blossom Nut		4
14	Carriage M8*60 Bolt		2
15	M8 Nut		2
16	Hitch Stabilizer		1
17	Straps		3
18	Strap Protector		4
19	Key		3
20	Wrench		1

INSTALLATION GUIDE:

Step 1 Installing the hitch bar (1) into the car 2" hitch receiver, secure with hitch lock (6). Then Install the hitch stabilizer (16).

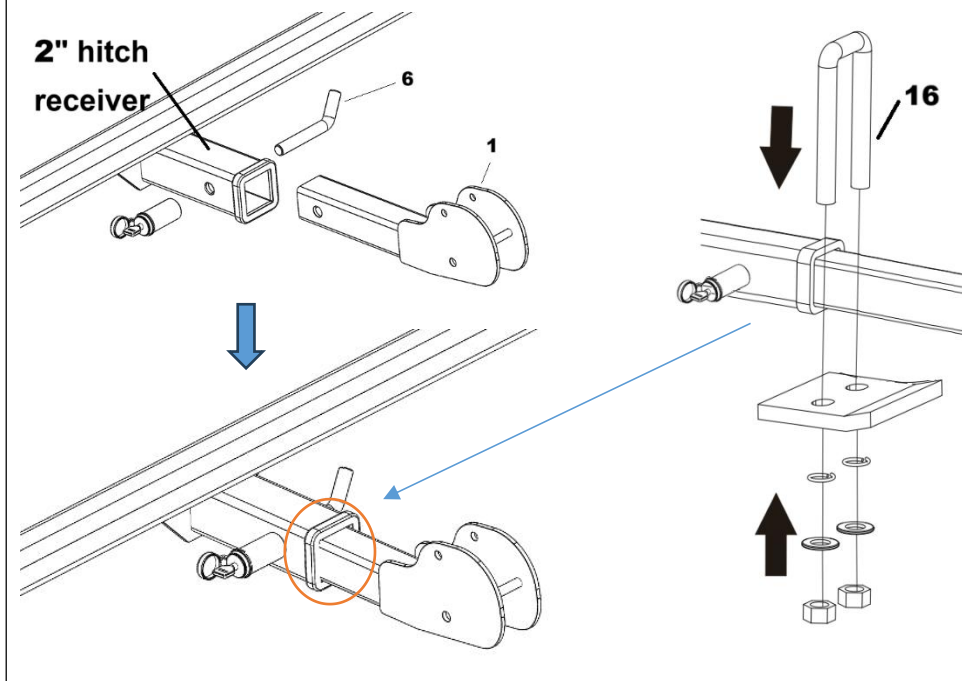

Step 2 Assemble the lower post(2) onto the hitch bar(1) with part bolts.

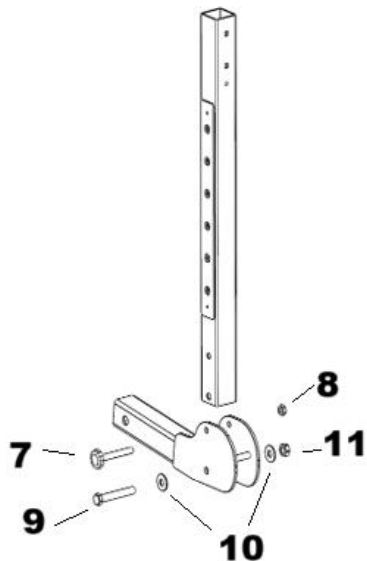

Step 3 Assemble the top post(3) into the bottom post(2) with bolts and nuts.

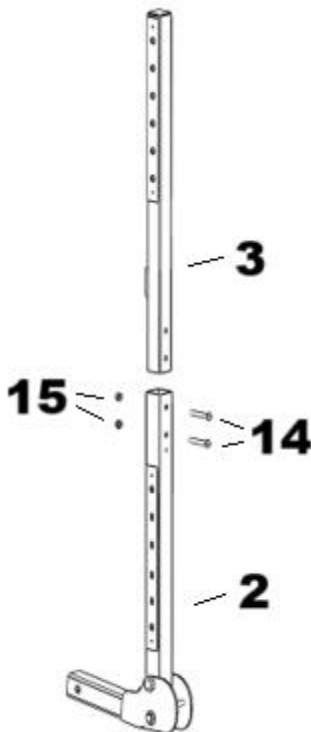

Step 4 Assemble the top rack on the top post by parts 12 and 13, assemble the bottom rack on the bottom post at suitable height.

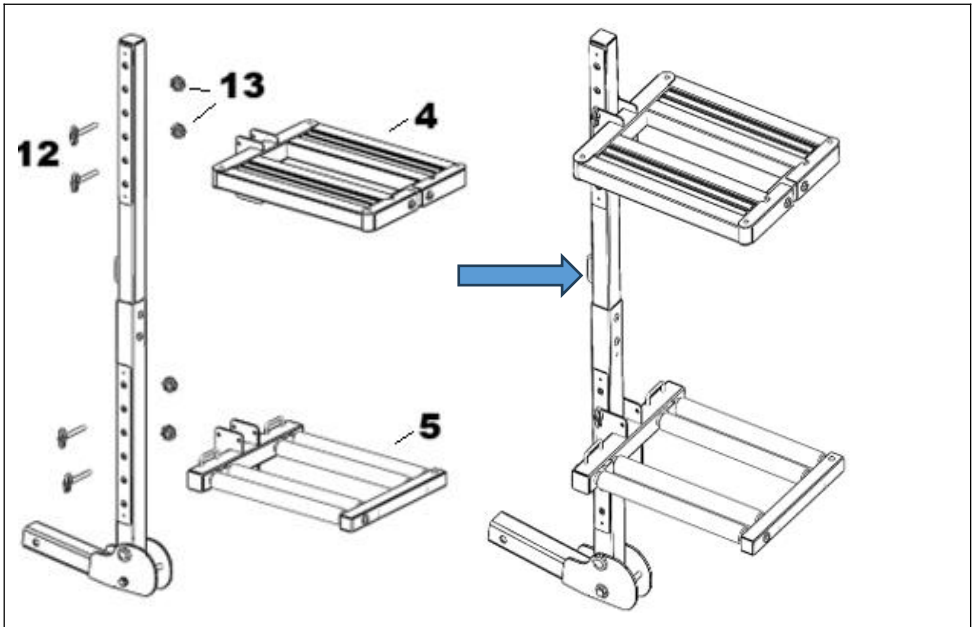

Step 5 Open the 3 locks, put the skis or snowboards (6 Pair Skis/4 Snowboards/ 2 snowboards+3 pairs of skis) in. Please distribute the load evenly on the rack, and don't overload.

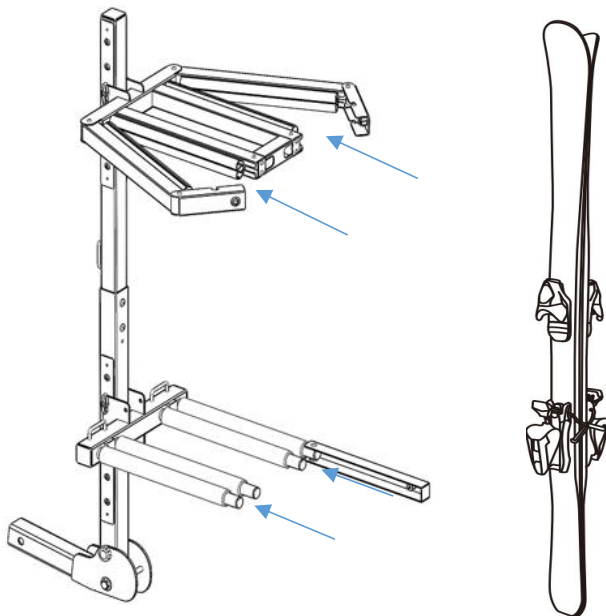

Then lock the rack, and please make sure lock it, and inspect the lock each time before using it.

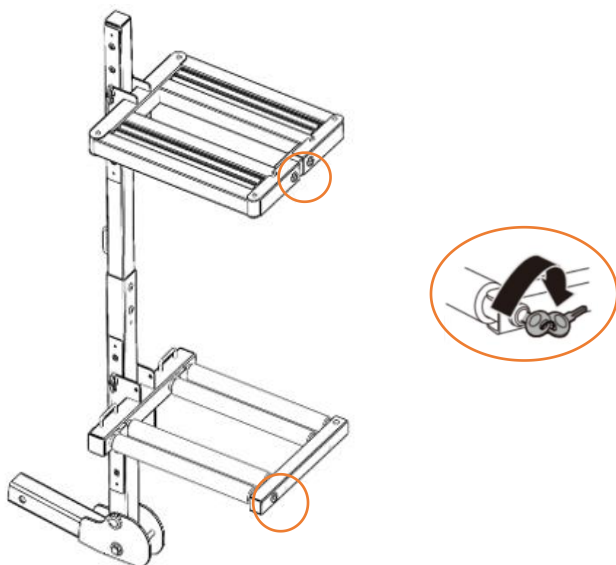

Step 6 Put the 4 pcs strap protectors onto the strap, and put them through the hook, adjust the protector position, secure the 3 pcs straps as shown below.

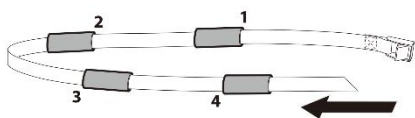

**Rack
Back**

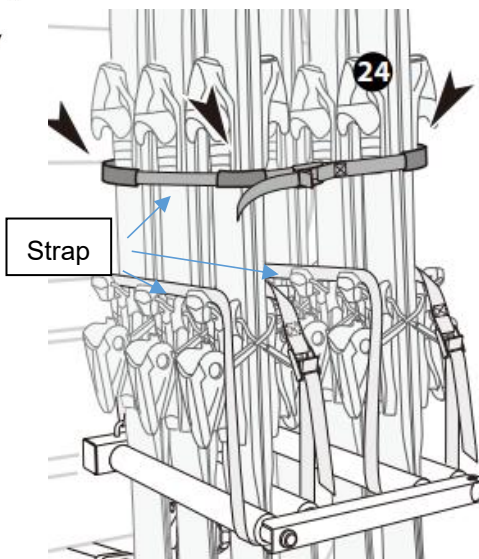

Step 7 Inspect again, and make sure the top rack and bottom rack's height is suitable for the snowboard, keep high from the snowboard bottom to the floor.

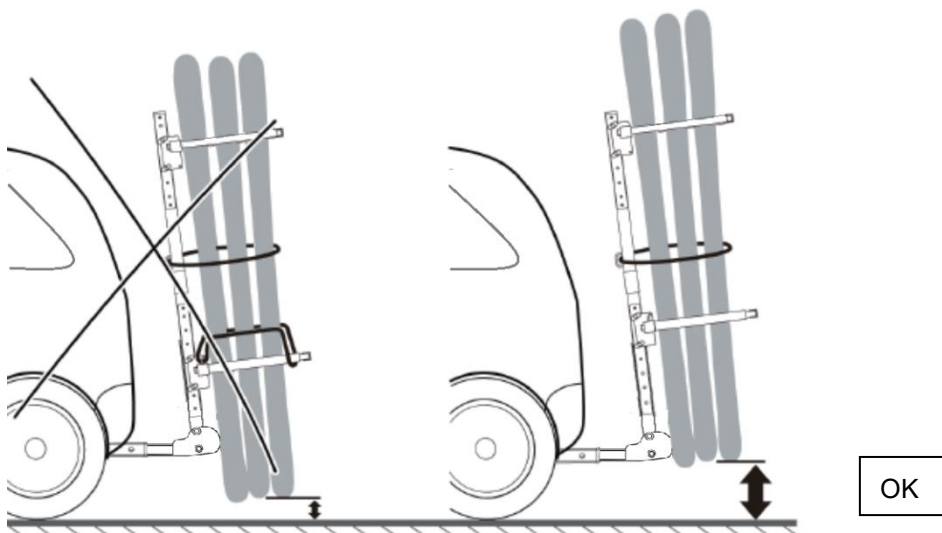

Step 9 Remove the T style M8*80 bolt, fold the bottom rack first, then remove the T style M8*80 and fold the upper rack second, and secure with the T style M8*80 bolt when not in use.

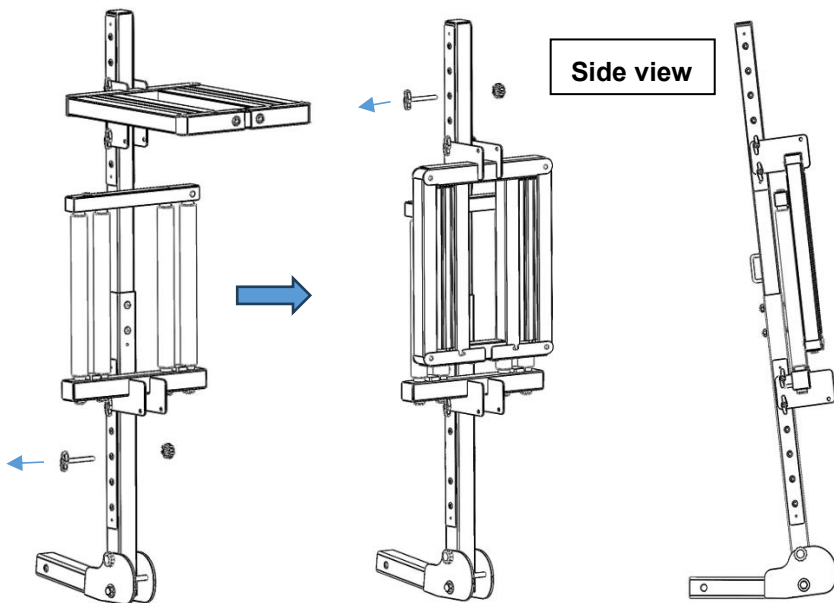

Step 10 Remove the M10*80 quick bolt and tilt the hitch rack , then you can open the car back door and get the luggage.

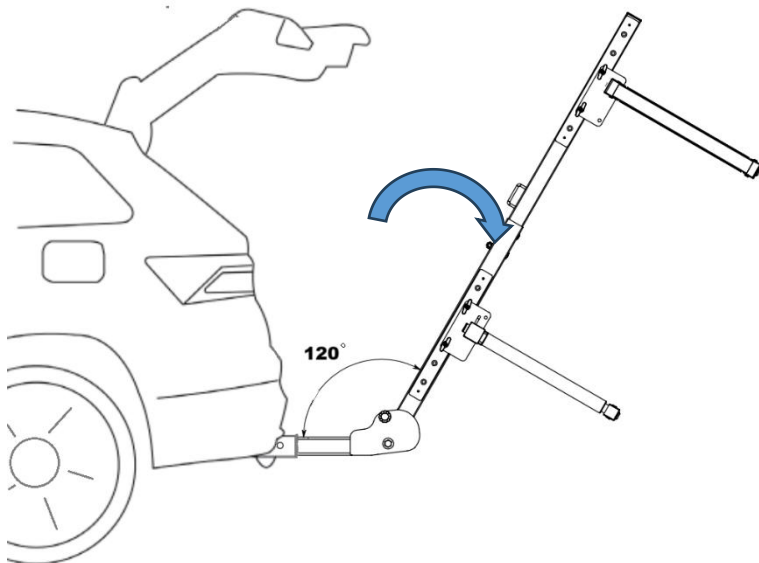

Manufacturer: Shanghaimuxinmuyeyouxiangongsi

Address: Shuangchenglu 803nong11hao1602A-1609shi, baoshanqu, shanghai 200000 CN.

Imported to AUS: SIHAO PTY LTD. 1 ROKEVA STREETEASTWOOD NSW 2122 Australia

Imported to USA: Sanven Technology Ltd. Suite 250, 9166 Anaheim Place, Rancho Cucamonga, CA 91730

UK	REP
-----------	------------

YH CONSULTING LIMITED.

C/O YH Consulting Limited Office 147, Centurion House, London Road, Staines-upon-Thames, Surrey, TW18 4AX

EC	REP
-----------	------------

E-CrossStu GmbH
Mainzer Landstr.69,
60329 Frankfurt am Main.



VEVOR

Affordable. Reliable. Home Improvement.

PORTE-SNOWBOARD SUR LE TOIT

MODÈLE : RN-2101

VEVOR

Affordable. Reliable. Home Improvement.

SNOWBOARD ROOF RACK

MODÈLE : RN-2101

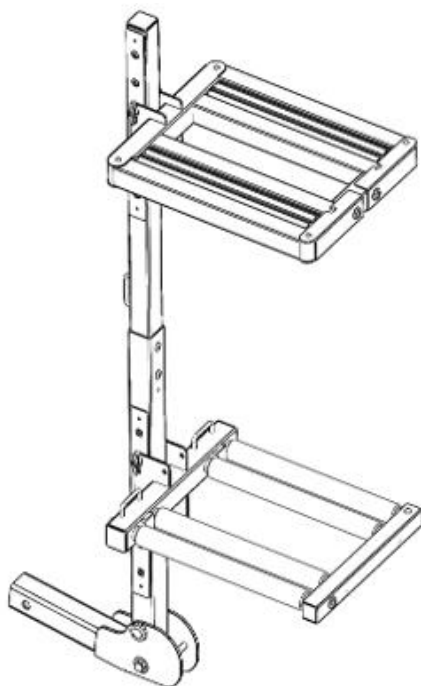

Ceci est le mode d'emploi d'origine. Veuillez lire attentivement l'intégralité du manuel avant utilisation. VEVOR se réserve le droit d'interpréter clairement ce manuel d'utilisation. L'apparence du produit dépend du produit que vous avez reçu. Veuillez nous excuser pour les éventuelles mises à jour technologiques ou logicielles.



Avertissement - Pour réduire le risque de blessure, l'utilisateur doit lire attentivement le manuel d'instructions.

AVERTISSEMENT:

VEUILLEZ LIRE ET COMPRENDRE TOUTES LES RÈGLES DE SÉCURITÉ AVANT

MONTAGE ET UTILISATION DE LA GALERIE DE TOIT S NOWBOARD.

RÈGLES DE SÉCURITÉ DE FONCTIONNEMENT :

10. Ne transportez pas plus de six paires de skis ou plus de quatre planches à neige sur le porte-bagages.
11. Le porte-skis/snowboards augmente la hauteur totale du véhicule. Attention au surplomb. obstacles lors de la conduite avec le porte-skis / snowboard.
12. Avant et après la conduite, ou après avoir chargé des skis ou un snowboard sur le porte-skis, vérifiez la sécurité des supports de support et resserrez-les si nécessaire.
13. Installez le porte-skis/snowboard après avoir installé les barres transversales sur le toit.
14. N'endommagez pas le toit et les autres surfaces finies de la carrosserie lors de l'installation du porte-skis/snowboard.
15. Faites attention au ski/snowboard avant d'ouvrir le hayon ou le hayon.
16. Retirez les porte-skis/snowboards avant d'entrer dans les stations de lavage automatique.
17. Le poids de la cargaison ne doit pas dépasser la limite de poids maximale de 165 lb (75 kg).
18. Vérifiez les boulons de montage avant chaque utilisation et conduisez à moins de 120 km/h (75 mph) pour plus de sécurité.

PRÉCAUTION



5. Évitez les démarrages ou les arrêts brusques avec le porte-vélos sur le véhicule. Cela peut provoquer le desserrage des fixations.
6. Respectez les lois et réglementations locales.
7. Avant de conduire, vérifiez que le porte-skis est bien verrouillé, que vous transportiez ou non des skis ou un les snowboards sont montés sur le support.
8. N'utilisez pas le porte-skis/snowboard pour transporter d'autres marchandises que des skis et des snowboards.







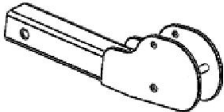

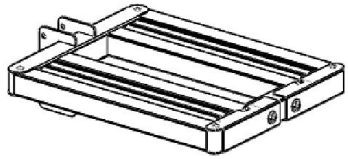

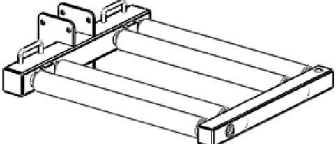
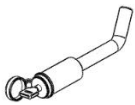

Enregistrez les instructions



CARACTÉRISTIQUES

Modèle	RN-2101
Matériel	Acier
Couleur	Noir
Capacité de charge	6 skis / 4 snowboards
Largeur de chargement	400 mm * 2
Récepteur d'attelage	2"
Poids maximum	165 lb (75 kg)

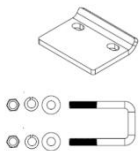
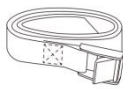
EMBALLER CONTENU

Partie	Description	image	Qté
1	Barre d' attelage		1
2	Poteau inférieur		1
3	Meilleur article		1
4	Panier supérieur		1

5	Panier inférieur		1
6	Verrou d'attelage		1
7	Boulon rapide M10*80		1
8	Serrure M10 Noix		1
9	Boulon hexagonal M12*80		1
10	Rondelle M12		2
11	Écrou M12		1
12	Boulons M8*80 de style T		4
13	Noix de prunier M8		4
14	Boulon de chariot M8*60		2
15	Écrou M8		2
16	Stabilisateur d' attelage		1
17	Sangles		3
18	Sangle de protection o r		4

19	Clé		3
20	Clé		1

GUIDE D' INSTALLATION :

Étape 1 Installation de la barre d'attelage (1) dans le récepteur d'attelage de 2 pouces, sécurisé avec un verrou d'attelage (6). Installez ensuite le stabilisateur d'attelage (16).

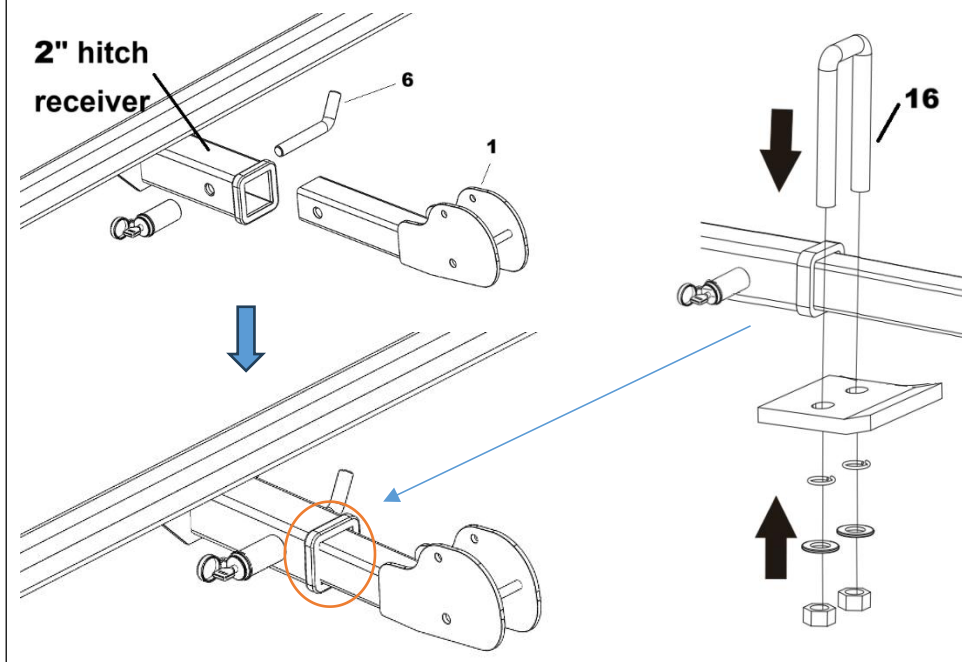

Étape 2 Assemblez le poteau inférieur (2) sur la barre d'attelage (1) avec des boulons partiels.

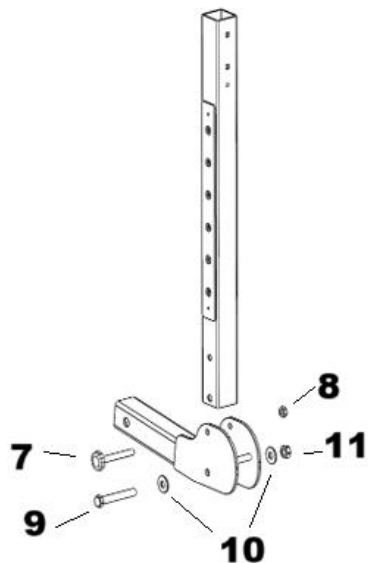

Étape 3 Assemblez le poteau supérieur (3) dans le poteau inférieur (2) avec des boulons et des écrous.

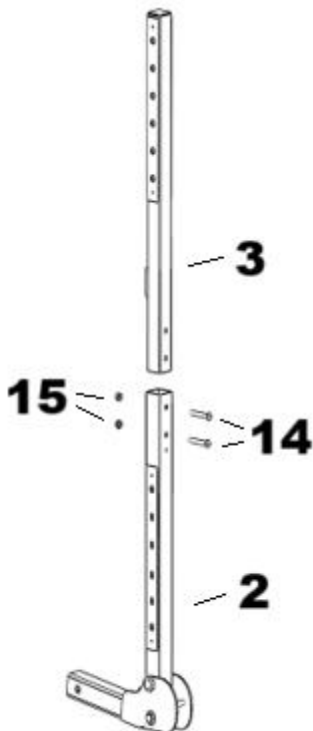

Étape 4 Assemblez le panier supérieur sur le poteau supérieur à l'aide des pièces 12 et 13, puis assemblez le panier inférieur sur le poteau inférieur à une hauteur appropriée.

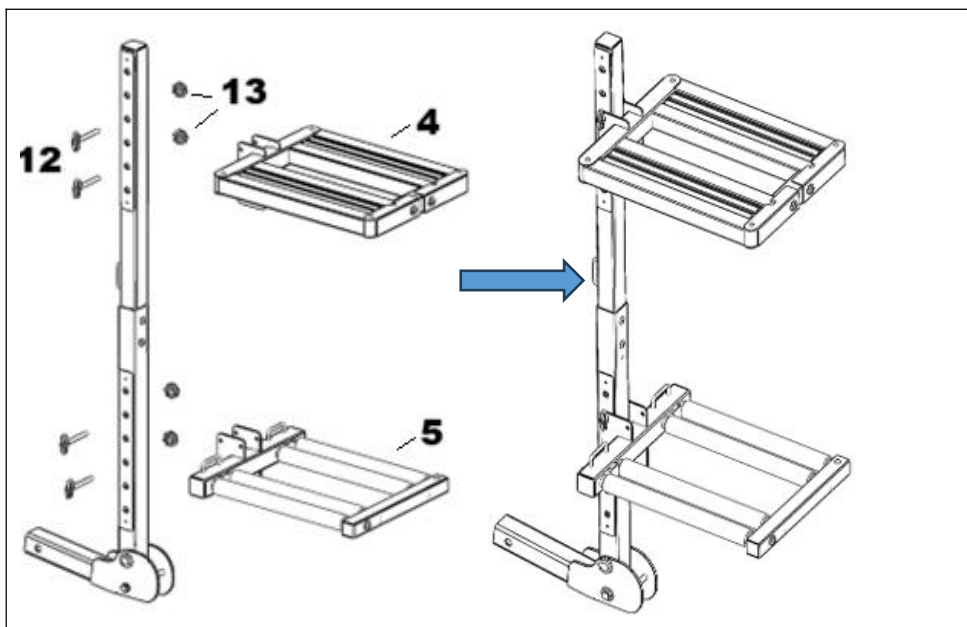

Étape 5 Ouvrez les 3 verrous, placez les skis ou les snowboards (6 paires de skis/4 snowboards/2 snowboards + 3 paires de skis) .
 Veuillez répartir la charge uniformément sur le support et ne pas surcharger .

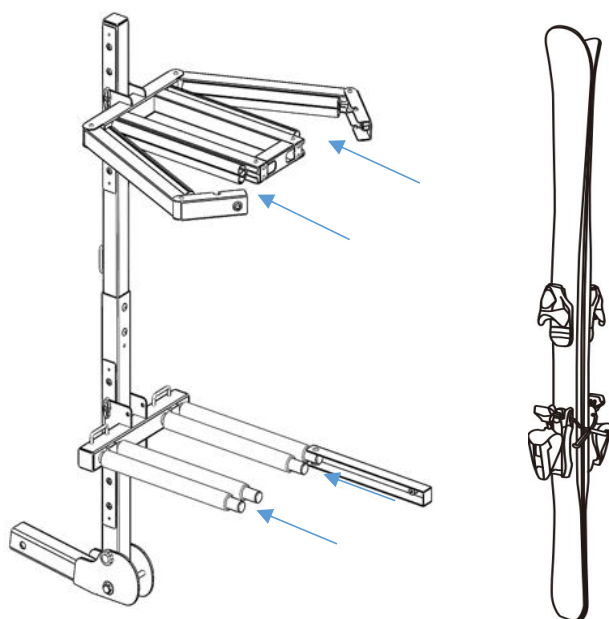

Verrouillez ensuite le rack, assurez-vous de le verrouiller et inspectez le verrou à chaque fois avant de l' utiliser .

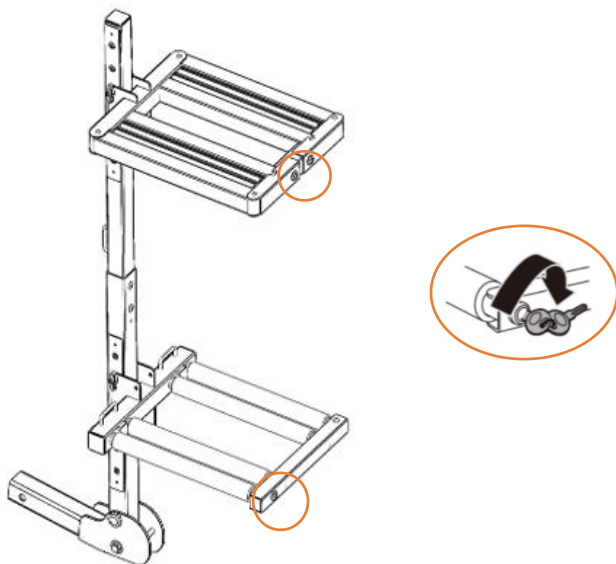

Étape 6 Placez les 4 protecteurs de sangle sur la sangle et passez- les dans le crochet, ajustez la position du protecteur, fixez les 3 sangles comme indiqué ci-dessous .

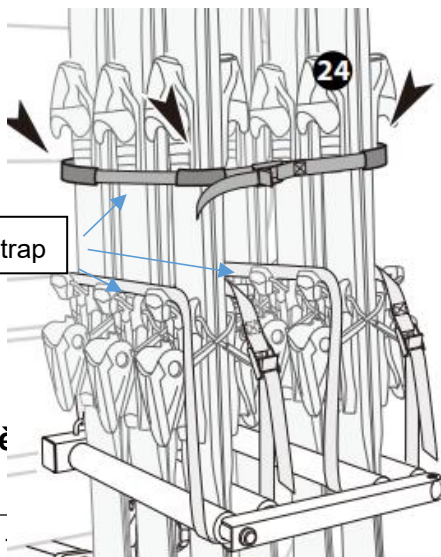
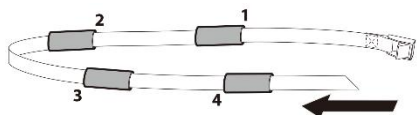

Étape 7 Inspectez à nouveau et assurez-vous que la hauteur du support supérieur et du support inférieur est adaptée au snowboard, maintenez-la haute du bas du snowboard jusqu'au sol.

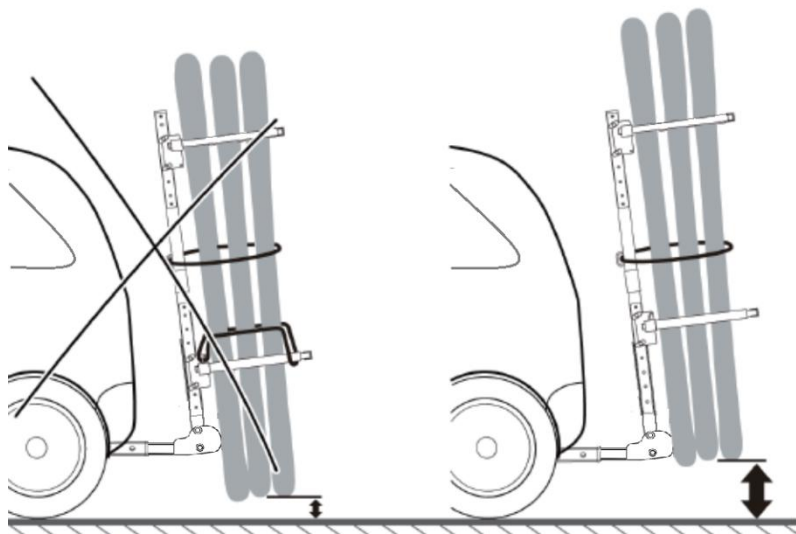

Étape 9 Retirez le boulon de style T M8*80 , pliez d'abord le support inférieur, puis retirez le boulon de style T M8*80 et pliez le support supérieur en second, puis fixez-le avec le boulon de style T M8*80 lorsqu'il n'est pas utilisé .

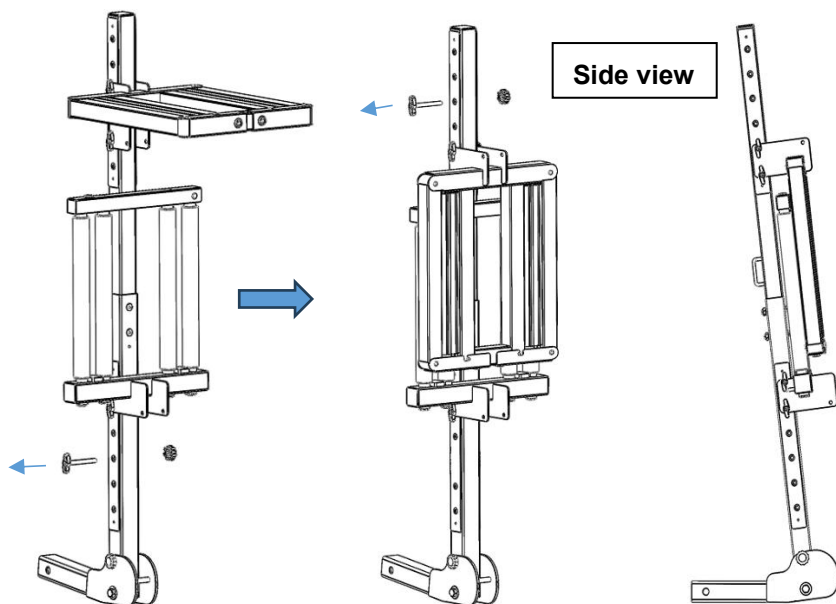

Étape 10 Retirez le boulon rapide M10*80 et inclinez le support d'attelage, puis vous pouvez ouvrir la porte arrière de la voiture et récupérer les bagages.

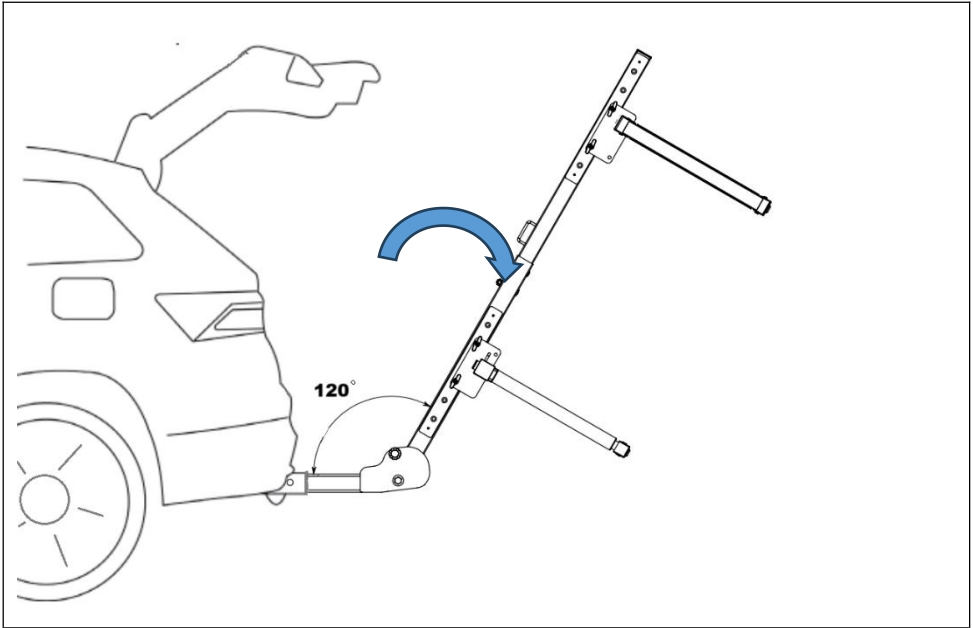

Fabricant : Shanghaimuxinmuyeyouxiangongsi

Adresse : Shuangchenglu 803nong11hao1602A-1609shi, baoshanqu, shanghai 200000 CN.

Importé en Australie : SIHAO PTY LTD. 1 ROKEVA STREET, ASTWOOD NSW 2122, Australie

Importé aux États-Unis : Sanven Technology Ltd. Suite 250, 9166 Anaheim Place, Rancho Cucamonga, CA 91730

UK	REP
----	-----

YH CONSULTING LIMITED.

C/O YH Consulting Limited Office 147, Centurion House, London Road, Staines-upon-Thames, Surrey, TW18 4AX

EC	REP
----	-----

E-CrossStu GmbH

Mainzer Landstr.69,
60329 Frankfurt am Main.



VEVOR

Affordable. Reliable. Home Improvement.

SNOWBOARD-DACHTRÄGER

MODELL : RN-2101

VEVOR

Affordable. Reliable. Home Improvement.

SNOWBOARD ROOF RACK

MODELL: RN-2101

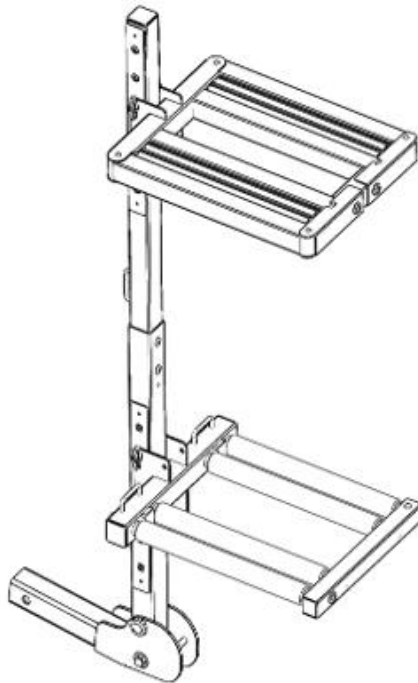

Dies ist die Originalanleitung. Bitte lesen Sie alle Anweisungen sorgfältig durch, bevor Sie das Gerät in Betrieb nehmen. VEVOR behält sich eine klare Auslegung unserer Bedienungsanleitung vor. Das Aussehen des Produkts hängt vom gelieferten Produkt ab. Bitte haben Sie Verständnis dafür, dass wir Sie nicht erneut über Technologie- oder Software-Updates informieren.



Warnung: Um das Verletzungsrisiko zu verringern, muss der Benutzer die Bedienungsanleitung sorgfältig lesen.

WARNUNG:

BITTE LESEN UND VERSTEHEN SIE ALLE SICHERHEITSREGELN, BEVOR MONTAGE UND VERWENDUNG DES SNOWBOARD DACHTRÄGERS.

REGELN FÜR DEN SICHEREN BETRIEB:

19. Transportieren Sie nicht mehr als sechs Paar Ski oder mehr als vier Snowboards auf dem Träger.
20. Der Ski-/Snowboardträger erhöht die Gesamthöhe des Fahrzeugs. Achten Sie auf Überkopf Hindernissen beim Fahren mit dem Ski-/Snowboardträger.
21. Vor und nach der Fahrt oder nach dem Laden von Skiern oder Snowboards auf den Träger überprüfen Sie die Sicherheit der Trägerhalterungen und ziehen Sie diese bei Bedarf nach.
22. Montieren Sie den Ski-/Snowboardträger, nachdem Sie die Querträger auf dem Dach montiert haben.
23. Beschädigen Sie bei der Montage des Ski-/Snowboardträgers nicht das Dach und andere Oberflächen der Karosserie.
24. Achten Sie auf den Ski/das Snowboard, bevor Sie die Heckklappe oder Heckklappe öffnen .
25. Vor dem Betreten von automatischen Waschanlagen die Ski-/Snowboardhalterungen abnehmen.
26. Das Gewicht der Ladung darf das maximale Gewicht von 165 lbs (75 kg) nicht überschreiten.
27. Überprüfen Sie vor jedem Gebrauch die Befestigungsschrauben und fahren Sie aus Sicherheitsgründen weniger als 120 km/h (75 mph).

VORSORGE



9. Vermeiden Sie plötzliches Anfahren oder Anhalten mit dem Träger am Fahrzeug. Dies kann dazu führen, dass sich Befestigungselemente lösen.
10. Befolgen Sie die örtlichen Gesetze und Vorschriften.
11. Prüfen Sie vor der Fahrt, ob der Träger sicher verriegelt ist, unabhängig davon, ob Skier oder ein Snowboard werden auf dem Träger montiert.
12. Verwenden Sie den Ski-/Snowboardträger nicht zum Transport anderer Güter als Ski und Snowboard.







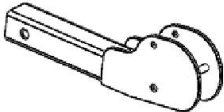

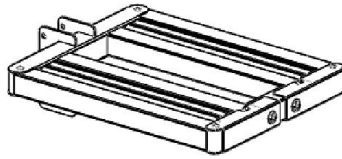

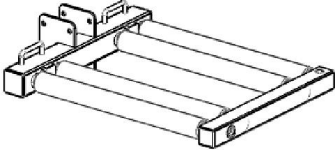
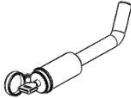
Speichern Sie die Anweisungen



TECHNISCHE DATEN

Modell	RN-2101
Material	Stahl
Farbe	Schwarz
Tragfähigkeit	6 Pr Ski / 4 Snowboards
Ladebreite	400 mm * 2
Anhängerkupplung	2"
Max. Gewicht	75 kg

PAKET INHALT

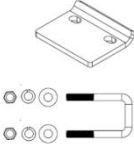
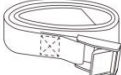
Teil	Beschreibung	Bild	MENGE
1	Anhängerkupplung		1
2	Unterer Pfosten		1
3	Top -Beitrag		1
4	Top Rack		1

5	Unteres Rack		1
6	Anhängerkupplungs- schloss		1
7	M10*80 Schnellschraube		1
8	M10 Schloss Nuss		1
9	M12*80 Sechskantschraube		1
10	M12 Unterlegscheibe		2
11	M12 Mutter		1
12	T-Stil M8*80 Schrauben		4
13	M8 Pflaumenblütenmutter		4
14	Schlitten M8*60 Bolzen		2
15	M8 Mutter		2
16	Anhängerkupplungs- stabilisator		1
17	Riemen		3

18	Strap Protector		4
19	Schlüssel		3
20	Wrench		1

INSTALLATIONSANLEITUNG :

Schritt 1 Anbringen der Deichsel (1) in die 2" Anhängerkupplung des Autos, mit Anhängerkupplungsschloss sichern (6). Installieren Sie dann den Anhängerkupplungsstabilisator (16).

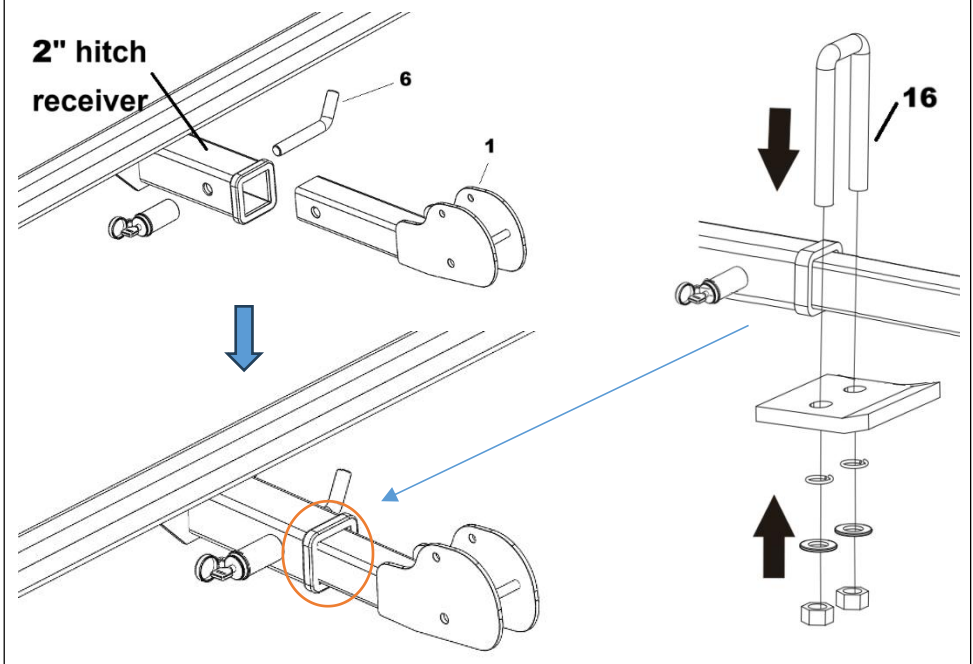

Schritt 2: Montieren Sie den unteren Pfosten (2) mit Teilbolzen an der Deichsel (1) .

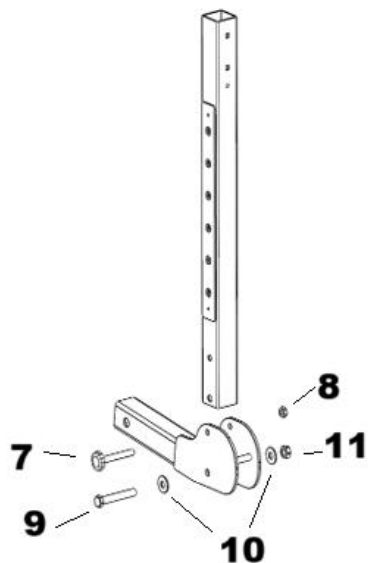

Schritt 3 Montieren Sie den oberen Pfosten (3) mit Schrauben und Muttern in den unteren Pfosten (2) ein .

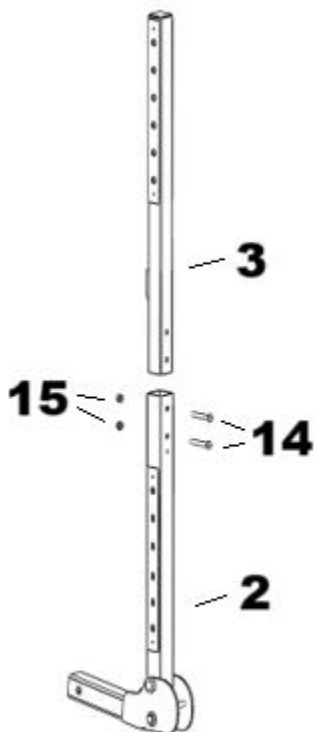

Schritt 4: Montieren Sie das obere Gestell mit den Teilen 12 und 13 am oberen Pfosten und das untere Gestell in geeigneter Höhe am unteren Pfosten .

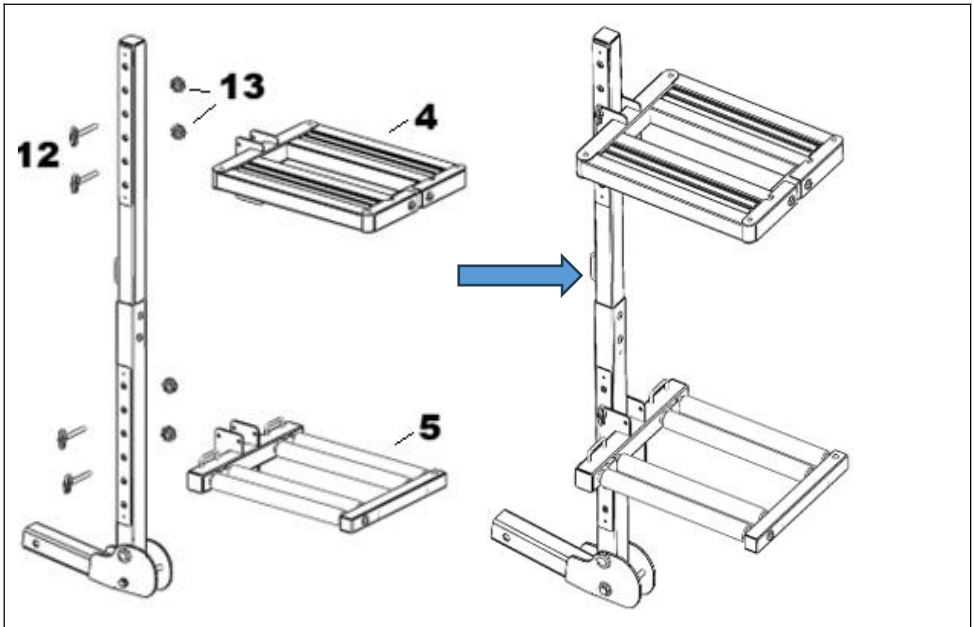

Schritt 5: Öffnen Sie die 3 Schlösser und legen Sie die Skier oder Snowboards (6 Paar Ski/4 Snowboards/2 Snowboards + 3 Paar Ski) hinein . Bitte verteilen Sie die Last gleichmäßig auf dem Gepäckträger und überladen Sie ihn nicht .

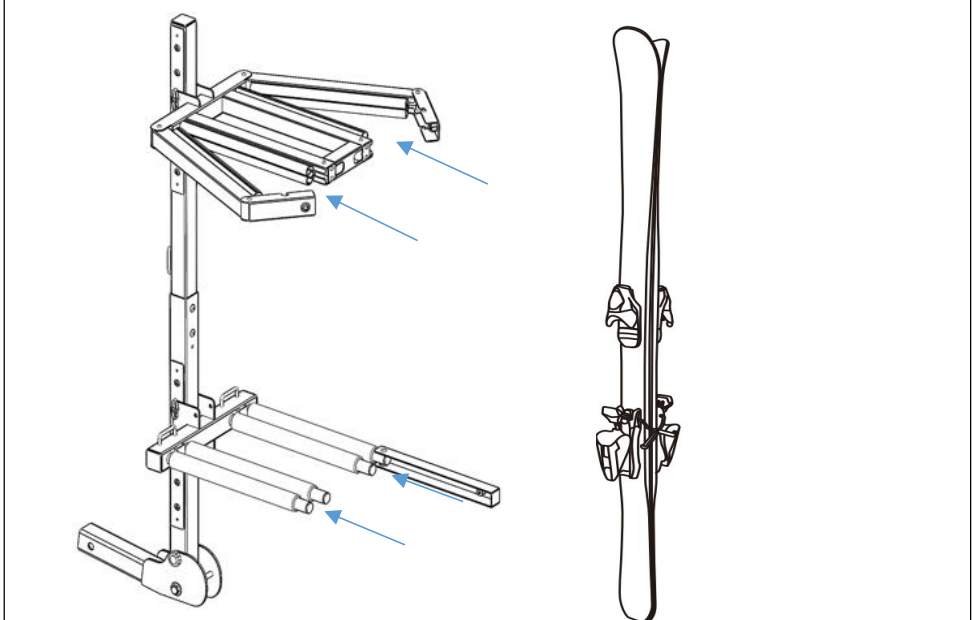

Schließen Sie anschließend das Rack ab. Achten Sie darauf, dass es verschlossen ist, und überprüfen Sie das Schloss vor jeder Verwendung .

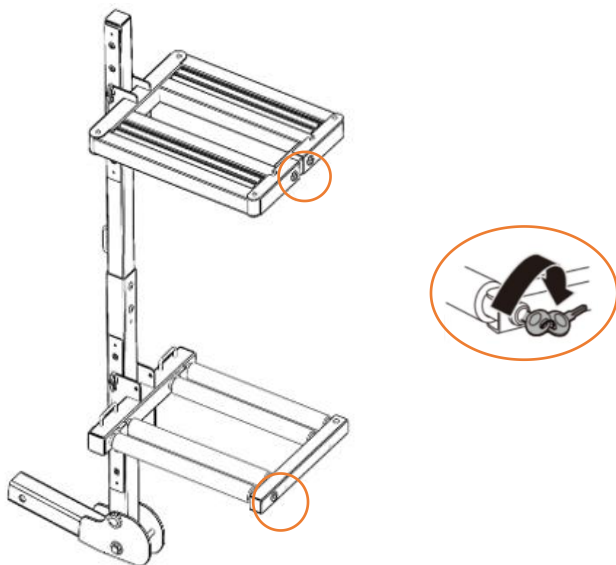

Schritt 6: Setzen Sie die 4 Gurtschützer auf den Gurt und führen Sie sie durch den Haken. Passen Sie die Position des Schutzes an und befestigen Sie die 3 Gurte wie unten gezeigt .

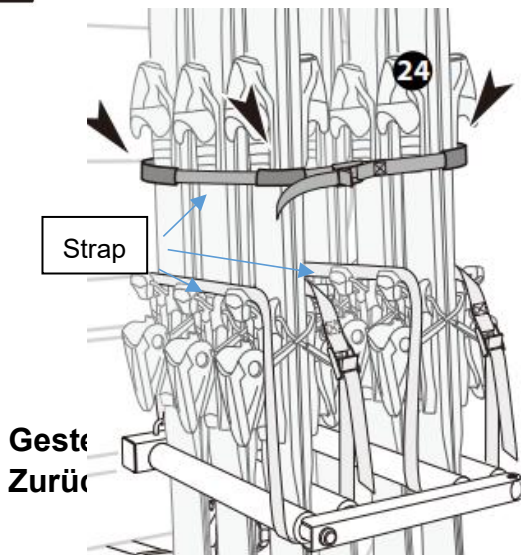
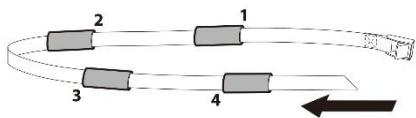

Schritt 7: Überprüfen Sie noch einmal und stellen Sie sicher, dass die Höhe des oberen und unteren Gestells für das Snowboard geeignet ist. Halten Sie den Abstand zwischen der Unterseite des Snowboards und dem Boden hoch.

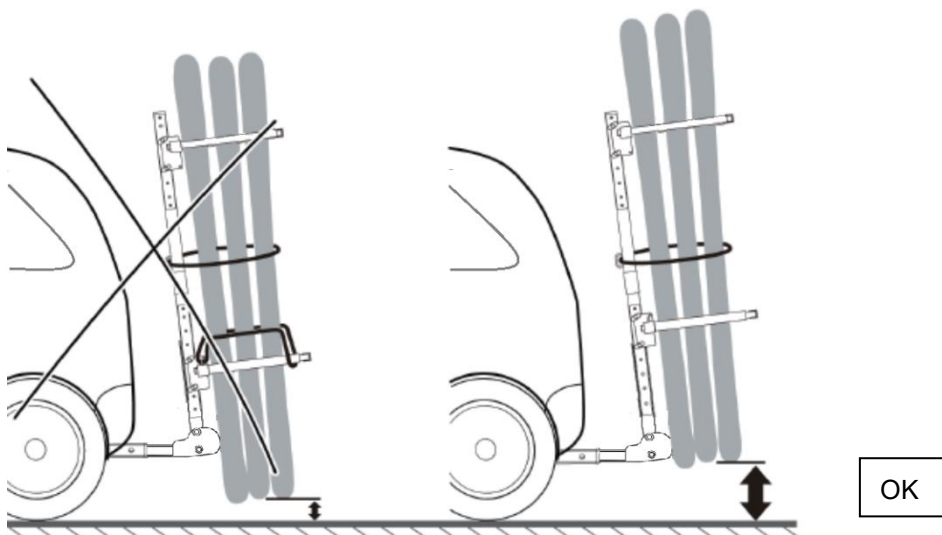

Schritt 9: Entfernen Sie die T-Schraube M8*80 , klappen Sie zuerst das untere Gestell um, entfernen Sie dann die T-Schraube M8*80 und klappen Sie als zweites das obere Gestell um und befestigen Sie es mit der T-Schraube M8*80, wenn es nicht verwendet wird.

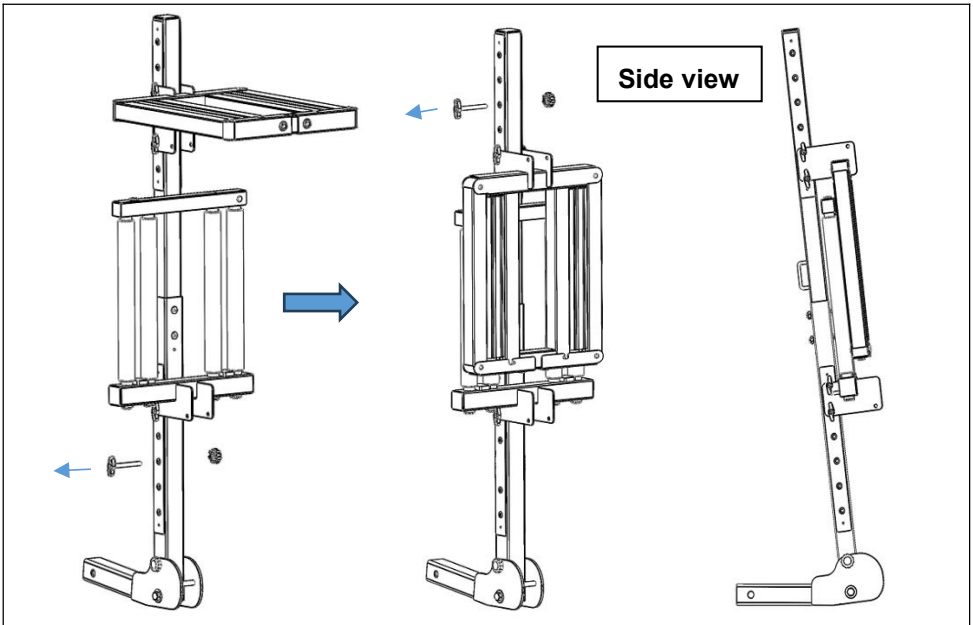

Schritt 10 Entfernen Sie die M10*80-Schnellschraube und kippen Sie den Kupplungsträger. Dann können Sie die hintere Autotür öffnen und das Gepäck herausholen.

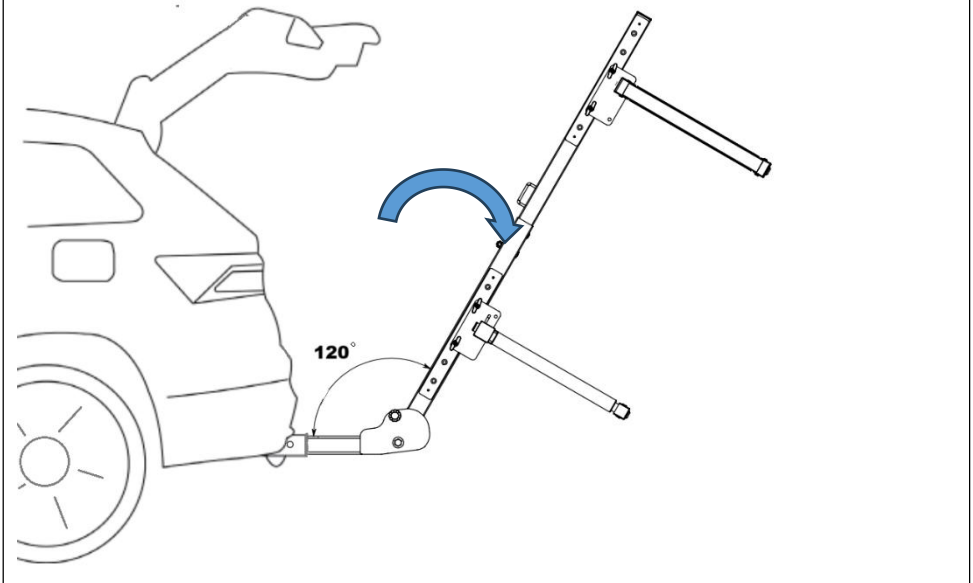

Hersteller: Shanghaimuxinmuyeyouxiangongsi

Adresse: Shuangchenglu 803nong11hao1602A-1609shi, baoshanqu, Shanghai 200000 CN.

Importiert nach AUS: SIHAO PTY LTD. 1 ROKEVA STREETEASTWOOD NSW 2122 Australien

Importiert in die USA: Sanven Technology Ltd. Suite 250, 9166 Anaheim Place, Rancho Cucamonga, CA 91730



YH CONSULTING LIMITED.

C/O YH Consulting Limited Office 147, Centurion House, London Road, Staines-upon-Thames, Surrey, TW18 4AX



E-CrossStu GmbH

Mainzer Landstr.69,
60329 Frankfurt am Main.



VEVOR

Affordable. Reliable. Home Improvement.

PORTAPACCHI PER SNOWBOARD

MODELLO : RN-2101

VEVOR

Affordable. Reliable. Home Improvement.

SNOWBOARD ROOF RACK

MODELLO: RN-2101

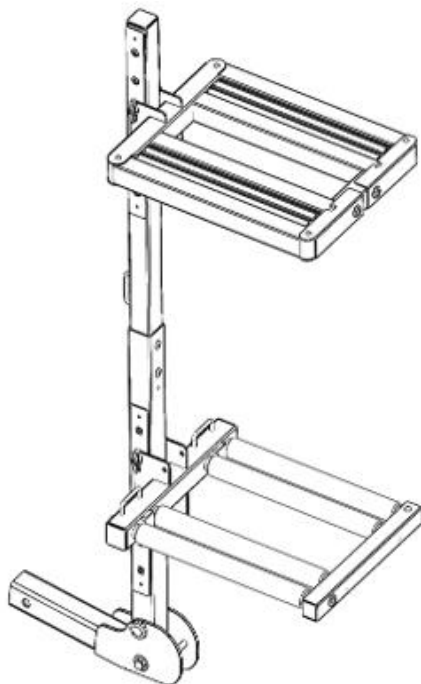

Queste sono le istruzioni originali, si prega di leggere attentamente tutte le istruzioni del manuale prima dell'uso. VEVOR si riserva la piena interpretazione del proprio manuale utente. L'aspetto del prodotto dipenderà dal prodotto ricevuto. Vi preghiamo di scusarci se non vi informeremo più in caso di aggiornamenti tecnologici o software sul nostro prodotto.



Avvertenza: per ridurre il rischio di lesioni, l'utente deve leggere attentamente il manuale di istruzioni.

AVVERTIMENTO:

SI PREGA DI LEGGERE E COMPNDERE TUTTE LE REGOLE DI SICUREZZA PRIMA DI MONTAGGIO E UTILIZZO DEL PORTAPACCHI SNOWBOARD .

REGOLE PER UN FUNZIONAMENTO SICURO:

28. Non trasportare più di sei paia di sci o più di quattro snowboard sul portasci.
29. Il portasci/snowboard aumenta l'altezza complessiva del veicolo. Prestare attenzione al tetto, ostacoli durante la guida con il portasci/snowboard.
30. Prima e dopo la guida, o dopo aver caricato gli sci o uno snowboard sul portasci, controllare la sicurezza dei supporti del supporto e serrarli nuovamente se necessario.
31. Installare il portasci/snowboard dopo aver installato le barre trasversali sul tetto.
32. Non danneggiare il tetto e le altre superfici rifinite della carrozzeria durante l'installazione del portasci/snowboard.
33. Prestare attenzione agli sci/snowboard prima di aprire il portellone posteriore o il portellone posteriore.
34. Rimuovere i portasci/snowboard prima di entrare negli autolavaggi automatici.
35. Il peso del carico non deve superare il limite massimo di 165 libbre (75 kg).
36. Controllare sempre i bulloni di montaggio prima dell'uso e, per motivi di sicurezza, guidare a una velocità inferiore a 120 km/h (75 mph).

PRECAUZIONE



13. Evitare partenze o arresti improvvisi con il portabici sul veicolo. Potrebbero allentare i dispositivi di fissaggio.
14. Rispettare le leggi e i regolamenti locali.
15. Prima di mettersi alla guida, verificare che il portabici sia bloccato saldamente, indipendentemente dal fatto che siano trasportati o meno sci o un gli snowboard sono montati sul portapacchi.
16. Non utilizzare il portasci/snowboard per trasportare merci diverse da sci e snowboard.







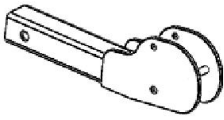

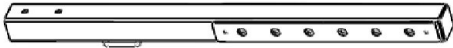
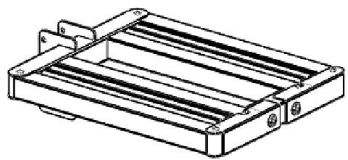

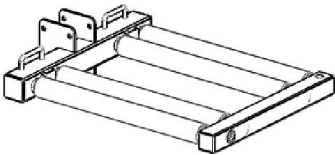
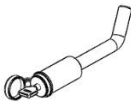

Salva le istruzioni



SPECIFICHE

Modello	RN-2101
Materiale	Acciaio
Colore	Nero
Capacità di carico	6 Pr Sci / 4 Snowboard
Larghezza di carico	400mm * 2
Ricevitore di attacco	2"
Peso massimo	165 libbre (75 kg)

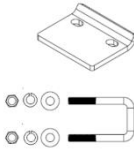
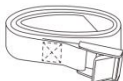
PACCHETTO CONTENUTO

Part e	Descrizione	immagine	QUA NTIT À
1	Barra di traino		1
2	Post inferiore		1
3	Post principale		1
4	Top Rack		1

5	Rack inferiore		1
6	Blocco del gancio		1
7	Bullone rapido M10*80		1
8	Lucchetto M10 Noce		1
9	Bullone esagonale M12*80		1
10	Rondella M12		2
11	Dado M12		1
12	Bulloni M8*80 stile T		4
13	Dado a fiore di prugna M8		4
14	Bullone M8*60 per carrello		2
15	Dado M8		2
16	Stabilizzatore di attacco		1
17	Cinghie		3
18	Cinghia di protezione o		4

19	Chiave		3
20	Chiave inglese		1

GUIDA ALL'INSTALLAZIONE :

Fase 1 Installazione della barra di traino (1) in il ricevitore del gancio di traino da 2" per auto , sicuro con il blocco del gancio (6). Quindi installare lo stabilizzatore del gancio (16).

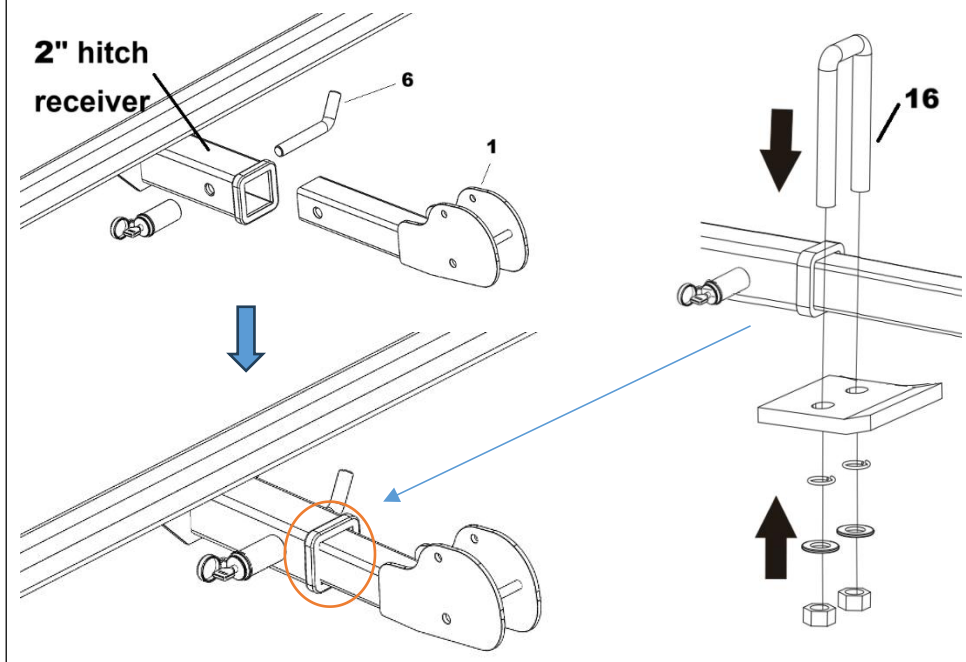

Fase 2 Montare il montante inferiore (2) sulla barra di traino (1) con bulloni parziali.

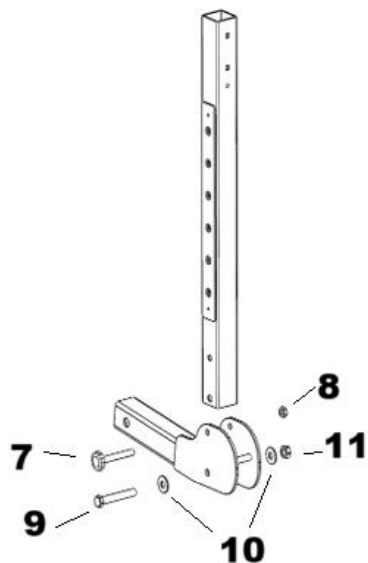

Fase 3 Assemblare il palo superiore (3) nel montante inferiore (2) con bulloni e dadi .

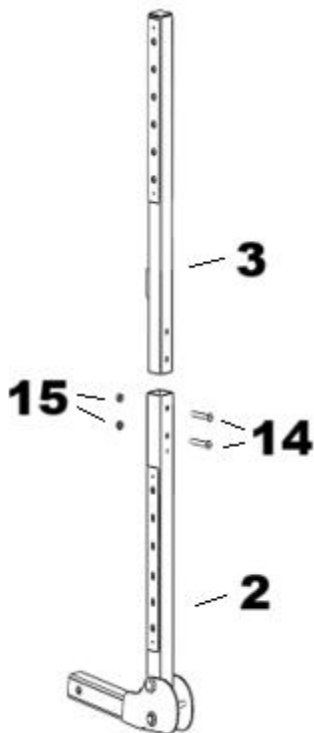

Fase 4: Montare il cestello superiore sul montante superiore tramite le parti 12 e 13 , quindi montare il cestello inferiore sul montante inferiore all'altezza adatta.

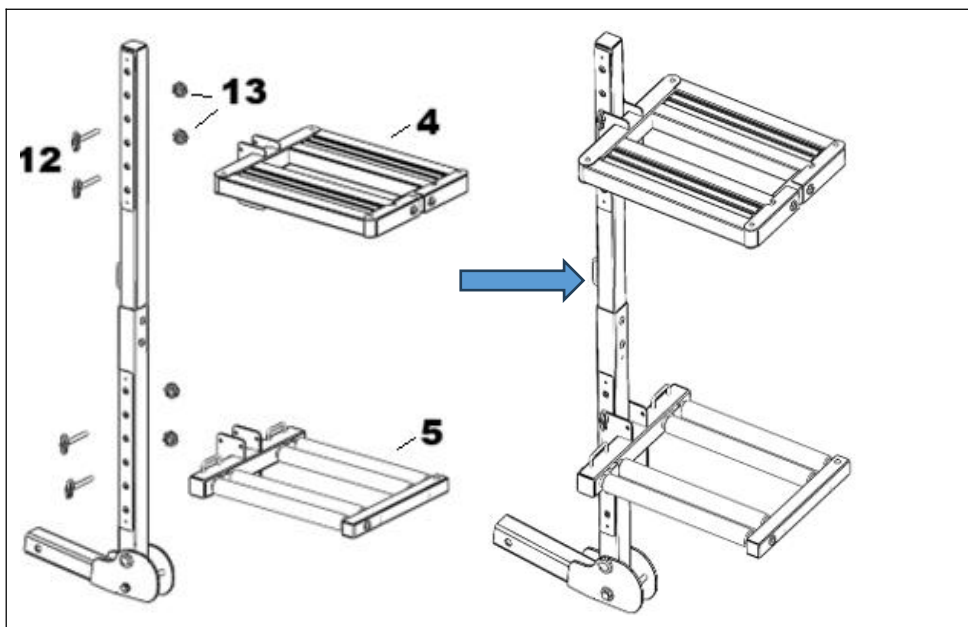

Fase 5 Aprire i 3 blocchi, inserire gli sci o gli snowboard (6 paia di sci/4 snowboard/2 snowboard + 3 paia di sci) . Distribuire il carico uniformemente sul portapacchi e non sovraccaricare .

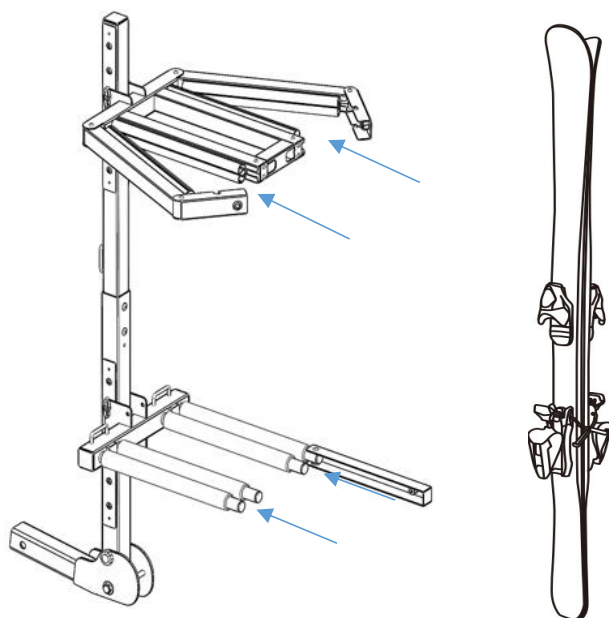

Quindi bloccare il rack e assicurarsi di bloccarlo, controllando il blocco ogni volta prima di utilizzarlo .

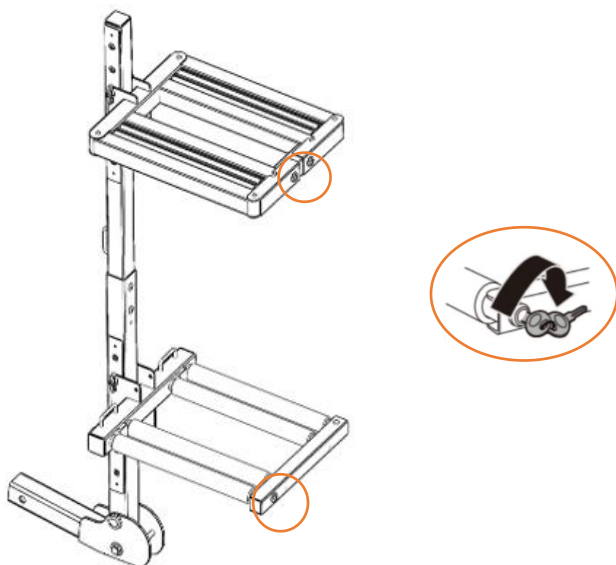

Fase 6: posizionare i 4 protettori del cinturino sul cinturino e farli passare attraverso il gancio, regolare la posizione del protettore e fissare i 3 cinturini come mostrato di seguito .

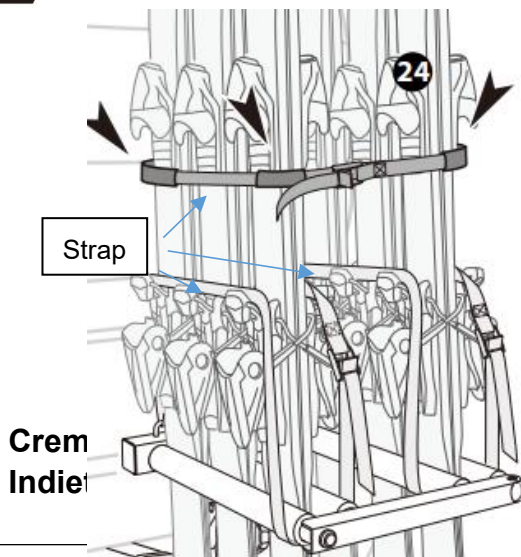
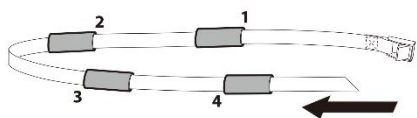

Fase 7 Ispezionare nuovamente e assicurarsi che l'altezza del portapacchi superiore e inferiore sia adatta allo snowboard, mantenendo l'altezza dalla base dello snowboard al pavimento.

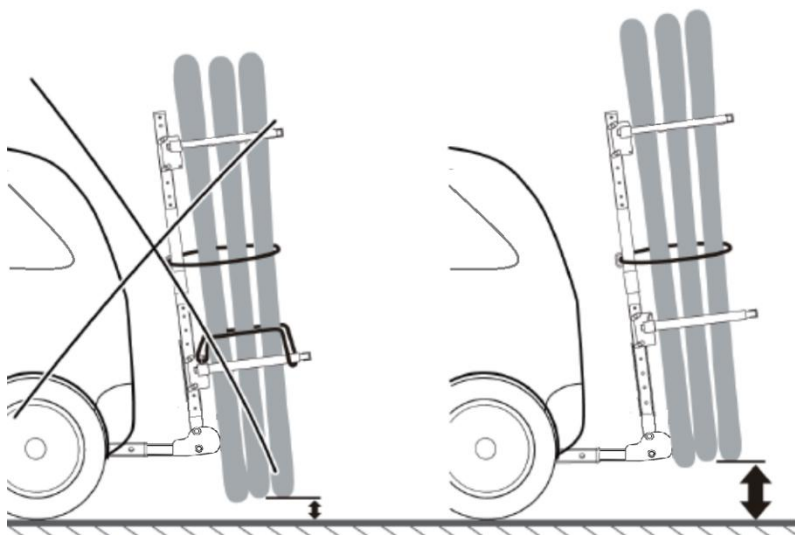

Fase 9 Rimuovere il bullone M8*80 a T , piegare prima il rack inferiore, quindi rimuovere il bullone M8*80 a T e piegare per secondo il rack superiore, quindi fissare con il bullone M8*80 a T quando non in uso.

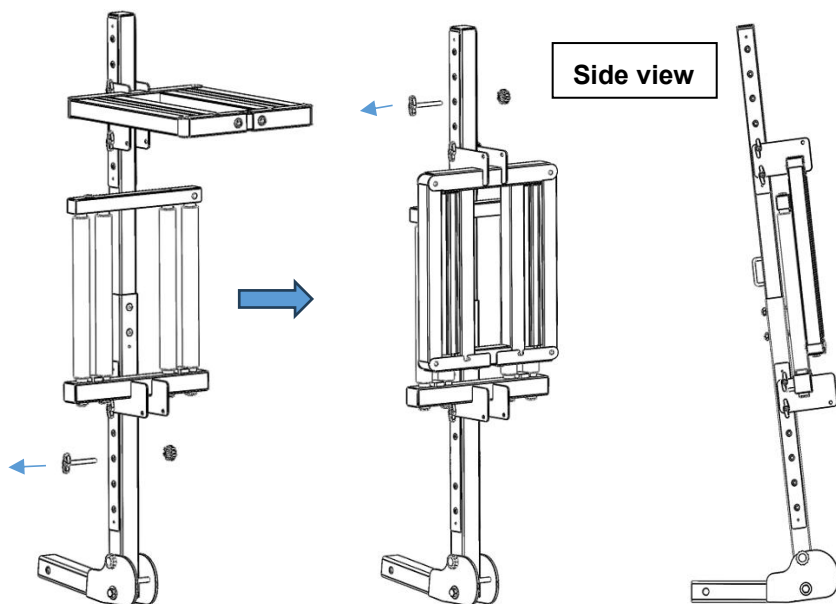

Fase 10 Rimuovere il bullone rapido M10*80 e inclinare il gancio di traino, quindi è possibile aprire il portellone posteriore dell'auto e prendere i bagagli.

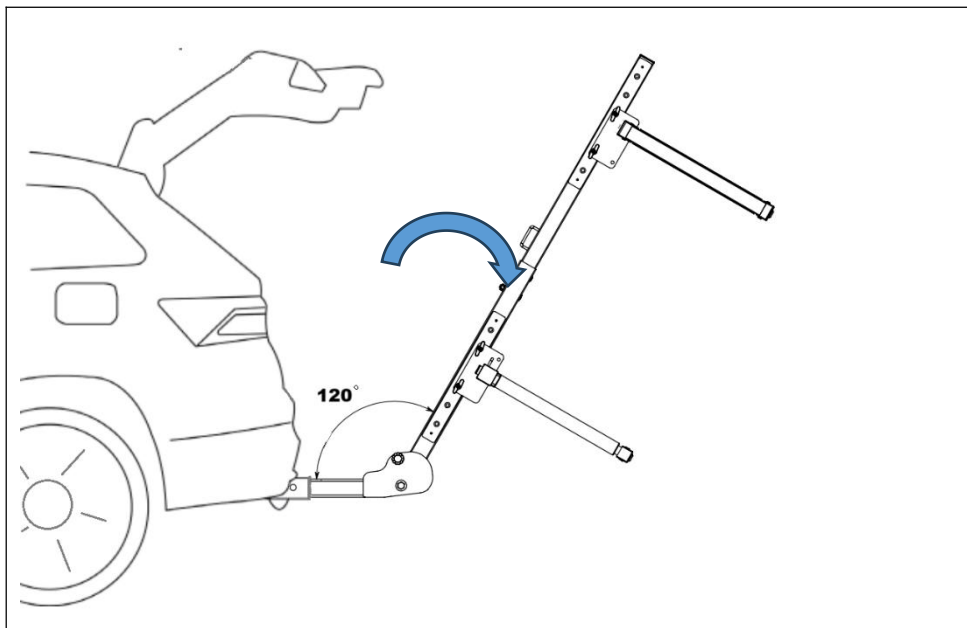

Produttore: Shanghaimuxinmuyeyouxiangongsi

Indirizzo: Shuangchenglu 803nong11hao1602A-1609shi, baoshanqu, shanghai 200000 CN.

Importato in AUS: SIHAO PTY LTD. 1 ROKEVA STREETEASTWOOD NSW 2122 Australia

Importato negli USA: Sanven Technology Ltd. Suite 250, 9166 Anaheim Place, Rancho Cucamonga, CA 91730

UK	REP
-----------	------------

YH CONSULTING LIMITED.

C/O YH Consulting Limited Office 147, Centurion House, London Road, Staines-upon-Thames, Surrey, TW18 4AX

EC	REP
-----------	------------

E-CrossStu GmbH
Mainzer Landstr.69,
60329 Frankfurt am Main.



VEVOR

Affordable. Reliable. Home Improvement.

PORTAEQUIPAJES PARA SNOWBOARD

MODELO : RN-2101

VEVOR

Affordable. Reliable. Home Improvement.

SNOWBOARD ROOF RACK

MODELO: RN-2101

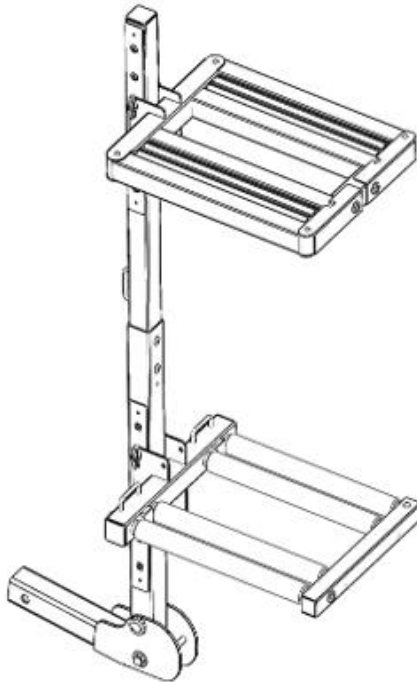

Estas son las instrucciones originales; lea atentamente todas las instrucciones del manual antes de utilizarlo. VEVOR se reserva el derecho de interpretar su manual de usuario. La apariencia del producto dependerá del producto que haya recibido. Le rogamos que nos disculpe si no le informamos de nuevo si hay actualizaciones tecnológicas o de software en nuestro producto.



Advertencia: Para reducir el riesgo de lesiones, el usuario debe leer atentamente el manual de instrucciones.

ADVERTENCIA:

POR FAVOR LEA Y ENTIENDA TODAS LAS NORMAS DE SEGURIDAD ANTES

MONTAJE Y USO DEL BACA SNOWBOARD.

REGLAS PARA UNA OPERACIÓN SEGURA:

37. No transporte más de seis pares de esquís ni más de cuatro tablas de snowboard en el portaequipajes.
38. El portaesquís/snowboard eleva la altura total del vehículo. Preste atención a los límites de altura. obstáculos al conducir con el portaesquís/porta tablas de snowboard.
39. Antes y después de conducir, o después de cargar esquís o una tabla de snowboard en el portaesquís, compruebe el estado de seguridad. de los soportes del portador y vuelva a apretarlos según sea necesario.
40. Instale el portaesquís/snowboard después de instalar las barras transversales en el techo.
41. No dañe el techo ni otras superficies acabadas de la carrocería al instalar el portaesquís/snowboard.
42. Tenga en cuenta el esquí/la tabla de snowboard antes de abrir el portón trasero o la puerta trasera.
43. Retire los portaesquís/snowboard antes de entrar en los lavaderos automáticos de vehículos.
44. El peso de la carga no debe exceder el límite de peso máximo de 165 libras (75 kg).
45. Compruebe los pernos de montaje antes de cada uso y conduzca a menos de 120 km/h (75 mph) por seguridad.

PRECAUCIÓN

17. Evite arranques o paradas repentinas con el portaequipaje en el vehículo. Esto puede provocar que los sujetadores se aflojen.
18. Obedezca las leyes y regulaciones locales.

19. Antes de conducir, compruebe que el portaequipajes esté bien bloqueado, independientemente de si lleva o no esquís o un Las tablas de snowboard se montan en el portaequipajes.



20. No utilice el portaesquís/tablas de snowboard para transportar mercancías que no sean esquís o tablas de snowboard.







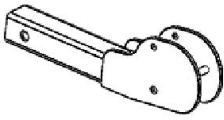

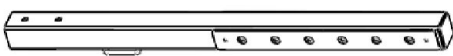
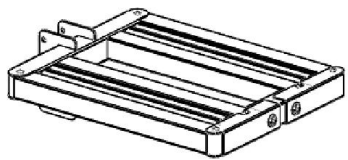

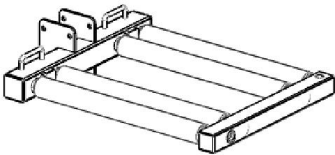
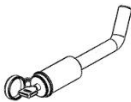

Guarde las instrucciones



PRESUPUESTO

Modelo	RN-2101
Material	Acero
Color	Negro
Capacidad de carga	6 esquís Pr / 4 tablas de snowboard
Ancho de carga	400 mm * 2
Receptor de enganche	2"
Peso máximo	165 libras (75 kg)

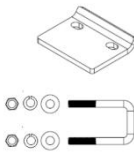
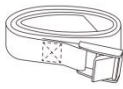
PAQUETE CONTENIDO

Part e	Descripción	imagen	CAN TIDA D
1	Barra de enganche		1
2	Poste inferior		1
3	Publicación superior		1
4	Rejilla superior		1

5	Rejilla inferior		1
6	Bloqueo de enganche		1
7	Perno rápido M10*80		1
8	Cerradura M10 Tuerca		1
9	Perno hexagonal M12*80		1
10	Arandela M12		2
11	Tuerca M12		1
12	Pernos estilo T M8*80		4
13	Tuerca de flor de ciruelo M8		4
14	Perno de carro M8*60		2
15	Tuerca M8		2
16	Estabilizador de enganche		1
17	Correas		3
18	Correa protectora o r		4

19	Llave		3
20	Llave inglesa		1

GUÍA DE INSTALACIÓN :

Paso 1 Instalación de la barra de enganche (1) en Receptor de enganche de 2" para automóvil , seguro con bloqueo de enganche (6) Luego instale el estabilizador del enganche. (16).

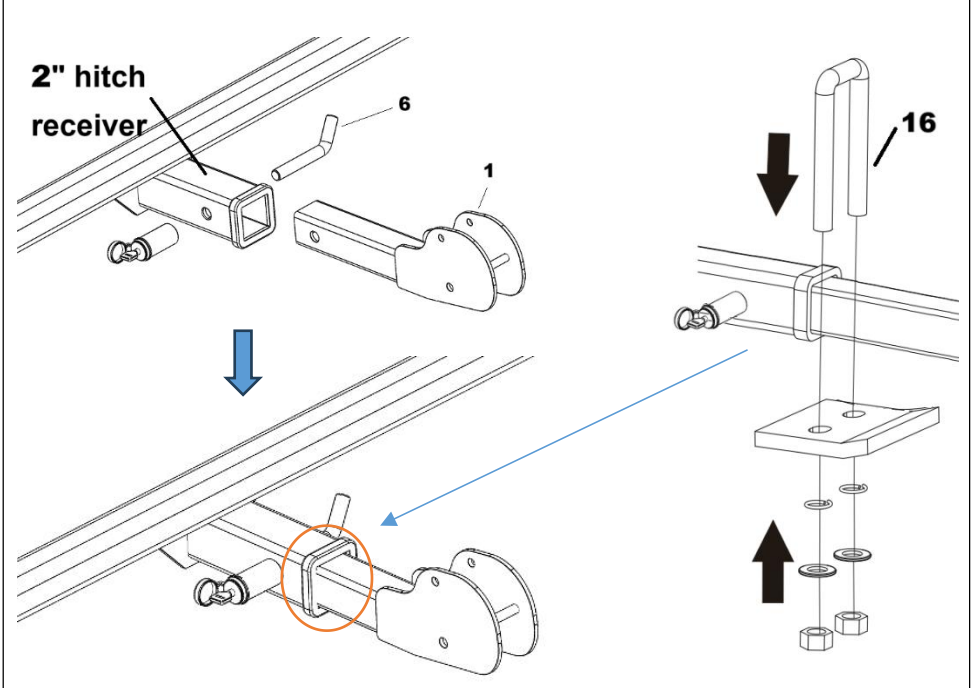

Paso 2 Ensamble el poste inferior (2) en la barra de enganche (1) con pernos parciales.

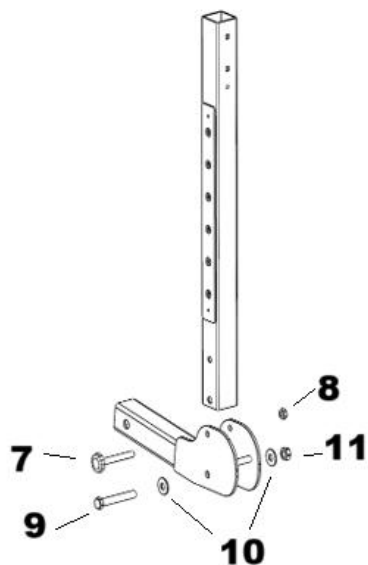

Paso 3 Ensamble el poste superior (3) en el poste inferior (2) con pernos y tuercas .

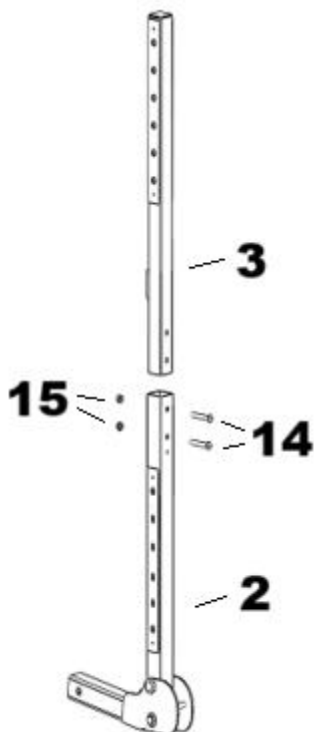

Paso 4 Ensamble el estante superior en el poste superior con las piezas 12 y 13 y luego ensamble el estante inferior en el poste inferior a la altura adecuada.

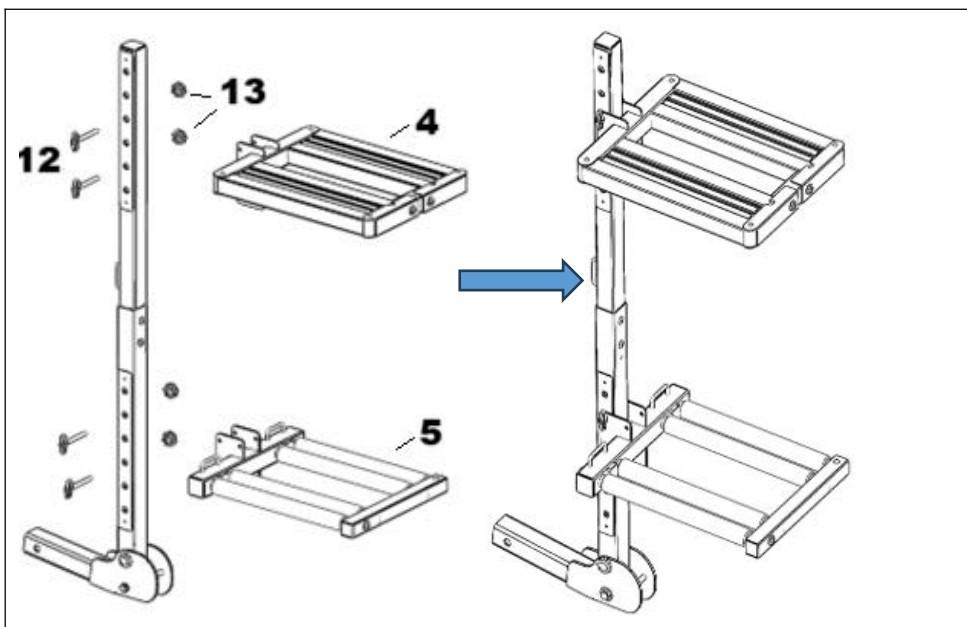

Paso 5 Abra los 3 candados, coloque los esquís o tablas de snowboard (6 pares de esquís/4 tablas de snowboard/2 tablas de snowboard + 3 pares de esquís) . Distribuya la carga uniformemente en el portaesquí y no lo sobrecargue .

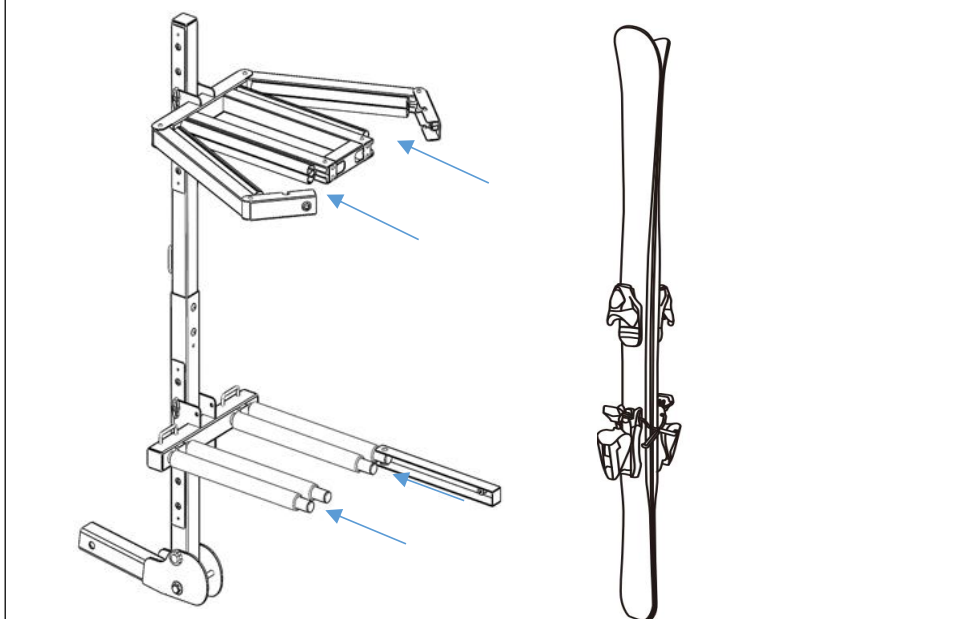

A continuación, bloquee el estante y asegúrese de bloquearlo e inspecciónelo cada vez antes de usarlo .

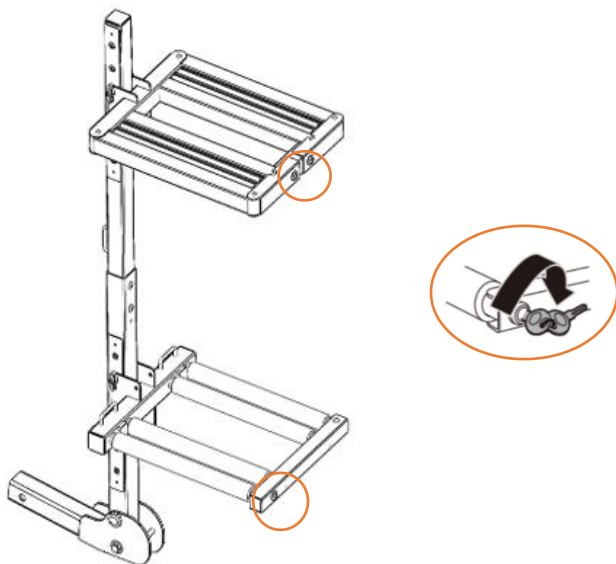

Paso 6 Coloque los 4 protectores de correa en la correa y páselos por el gancho, ajuste la posición del protector y asegure las 3 correas como se muestra a continuación .

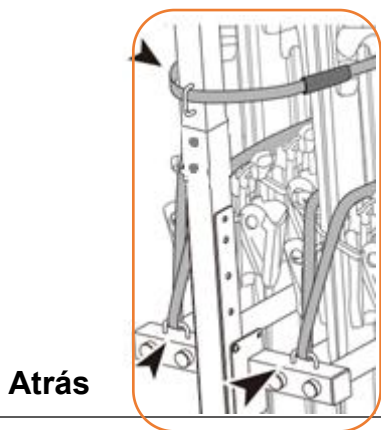
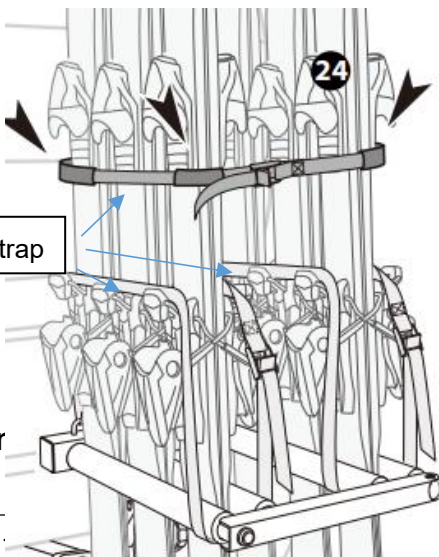
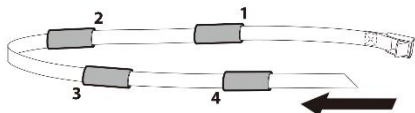

Estar

Atrás

Paso 7 Inspeccione nuevamente y asegúrese de que la altura del estante superior e inferior sea adecuada para la tabla de snowboard, manténgala alta desde la parte inferior de la tabla de snowboard hasta el piso.

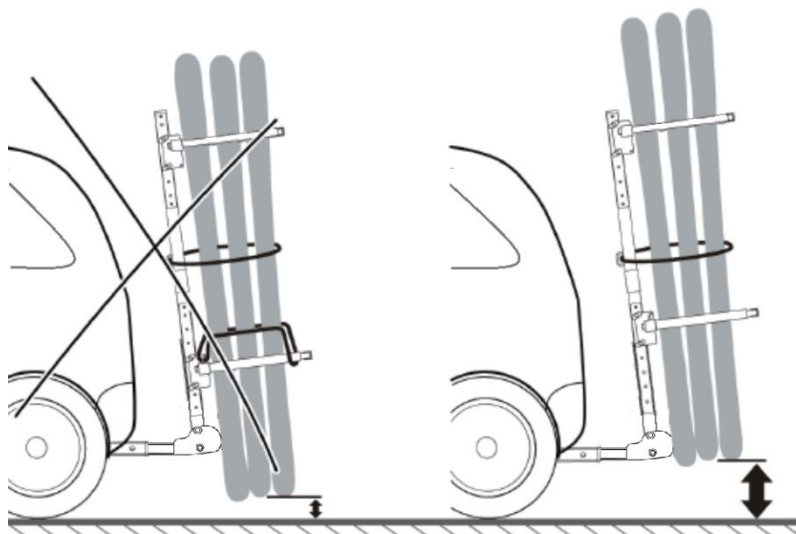

Paso 9 Retire el perno estilo T M8*80 , doble primero el estante inferior, luego retire el perno estilo T M8*80 y doble el estante superior por segundo, y asegúrelo con el perno estilo T M8*80 cuando no esté en uso.

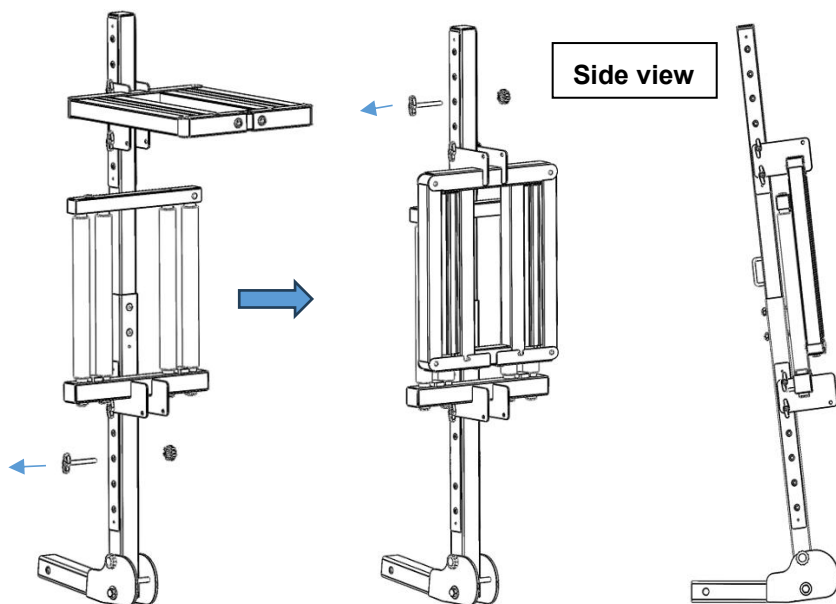

Paso 10 Retire el perno rápido M10*80 e incline el portaequipaje, luego podrá abrir la puerta trasera del automóvil y sacar el equipaje.

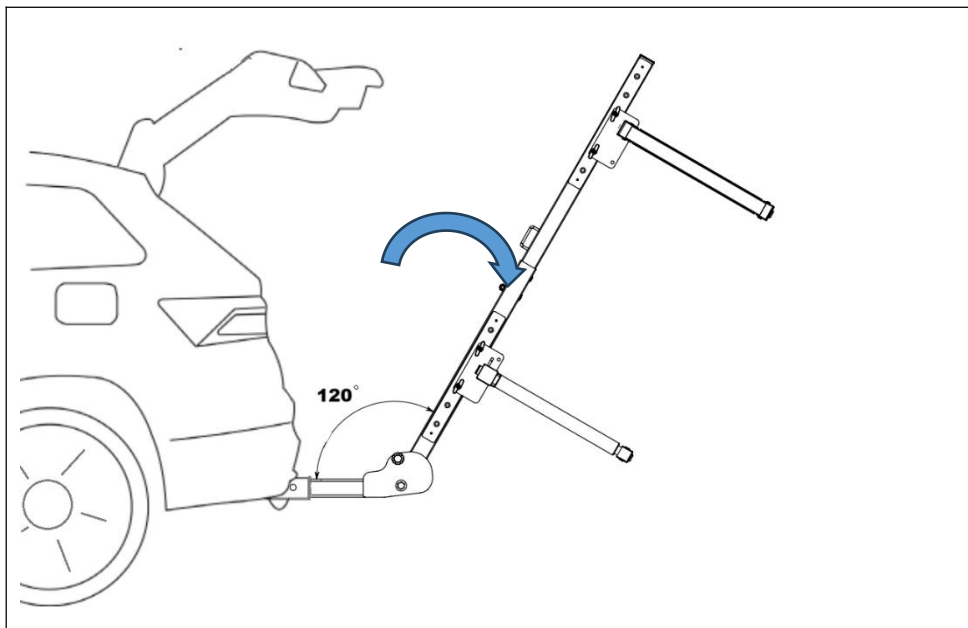

Fabricante: Shanghaimuxinmuyeyouxiangongsi

Dirección: Shuangchenglu 803nong11hao1602A-1609shi, baoshanqu, shanghai 200000 CN.

Importado a AUS: SIHAO PTY LTD. 1 ROKEVA STREET, EASTWOOD, NSW 2122, Australia

Importado a EE. UU.: Sanven Technology Ltd. Suite 250, 9166 Anaheim Place, Rancho Cucamonga, CA 91730

UK	REP
-----------	------------

YH CONSULTING LIMITED.

C/O YH Consulting Limited Office 147, Centurion House, London Road, Staines-upon-Thames, Surrey, TW18 4AX

EC	REP
-----------	------------

E-CrossStu GmbH
Mainzer Landstr.69,
60329 Frankfurt am Main.



VEVOR

Affordable. Reliable. Home Improvement.

BAGAŻNIK DACHOWY NA SNOWBOARD

MODEL : RN-2101

VEVOR

Affordable. Reliable. Home Improvement.

SNOWBOARD ROOF RACK

MODEL: RN-2101

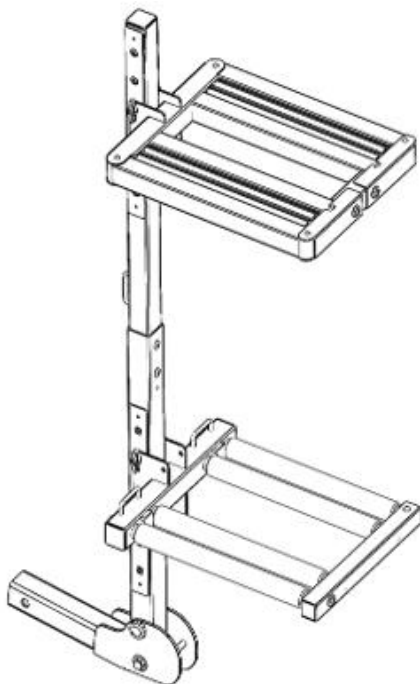

To jest oryginalna instrukcja obsługi. Przed użyciem prosimy o dokładne zapoznanie się z treścią instrukcji. Firma VEVOR zastrzega sobie prawo do jednoznacznej interpretacji niniejszej instrukcji obsługi. Wygląd produktu zależy od stanu, w jakim go otrzymali Państwo. Prosimy o wyrozumiałość, ale nie będziemy Państwa ponownie informować o aktualizacjach technologicznych lub oprogramowania naszego produktu.



Ostrzeżenie: Aby zminimalizować ryzyko obrażeń, użytkownik powinien uważnie przeczytać instrukcję obsługi.

OSTRZEŻENIE:

PRZED PRZYJŚCIEM PRZECZYTAJ I ZROZUMIEJ WSZYSTKIE ZASADY BEZPIECZEŃSTWA

MONTAŻ I UŻYTKOWANIE BAGAŻNIKA DACHOWEGO NA SNOWBOARD. ZASADY BEZPIECZNEJ EKSPLOATACJI:

46. Na bagażniku nie należy przewozić więcej niż sześciu par nart lub czterech desek snowboardowych.
47. Uchwyt na narty/snowboard podnosi całkowitą wysokość pojazdu. Zwróć uwagę na wysokość nad głową, przeszkody podczas jazdy z uchwytem na narty/snowboard.
48. Przed i po jeździe lub po załadowaniu nart lub deski snowboardowej na bagażnik należy sprawdzić jego bezpieczeństwo, mocowań nośnika i dokręć je w razie potrzeby.
49. Uchwyt na narty/snowboard należy zamontować po uprzednim zamontowaniu poprzeczek na dachu.
50. Podczas montażu uchwyty na narty/snowboard uważaj, aby nie uszkodzić dachu i innych wykończonych powierzchni nadwozia.
51. Zwróć uwagę na narty/snowboard przed otwarciem tylnej klapy lub bagażnika.
52. Przed wjazdem do automatycznej myjni samochodowej należy zdjąć uchwyty na narty/snowboard.
53. Waga ładunku nie może przekraczać maksymalnego limitu wagowego wynoszącego 165 funtów (75 kg).
54. Przed każdym użyciem należy sprawdzić śruby mocujące i ze względów bezpieczeństwa nie przekraczać prędkości 120 km/h (75 mph).

OSTROŻNOŚĆ

21. Unikaj gwałtownego ruszania i zatrzymywania się z bagażnikiem na pojeździe. Może to spowodować poluzowanie się mocowań.
22. Przestrzegaj lokalnych praw i przepisów.

23. Przed jazdą sprawdź, czy bagażnik jest bezpiecznie zablokowany, niezależnie od tego, czy przewozisz narty, czy rower. snowboard montowany jest na bagażniku.



24. Uchwytu na narty/snowboard nie należy używać do przewożenia innych rzeczy niż narty i snowboard.

Zapisz instrukcje

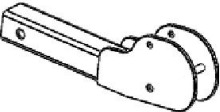

SPECYFIKACJE

Model	RN-2101
Tworzywo	Stal
Kolor	Czarny
Nośność	6 nart Pr / 4 deski snowboardowe
Szerokość załadunku	400 mm * 2
Odbiornik zaczepu	2"
Maksymalna waga	165 funtów (75 kg)

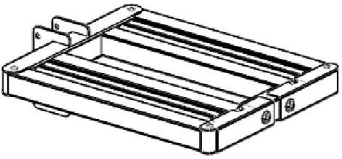
PAKIET ZAWARTOŚĆ

Część	Opis	zdjęcie	ILOŚĆ
1	Zaczep		1
2	Dolny słupek		1
3	Najlepszy post		1
4	Top Rack		1

5	Dolna półka		1
6	Blokada zaczepu		1
7	Śruba szybkozłączna M10*80		1
8	Zamek M10 Nakrętka		1
9	Śruba sześciokątna M12*80		1
10	Podkładka M12		2
11	Nakrętka M12		1
12	Śruby M8*80 typu T		4
13	Orzech M8 Kwiat Śliwy		4
14	Śruba M8*60 do wózka		2
15	Nakrętka M8		2
16	Stabilizator zaczepu		1
17	Paski		3

18	Ochrona paska lub		4
19	Klucz		3
20	W rench		1

INSTRUKCJA INSTALACJI :

Krok 1 Montaż belki zaczepowej (1) do zaczep samochodowy 2" zabezpieczony blokadą zaczepu (6) Następnie zamontuj stabilizator zaczepu (16).

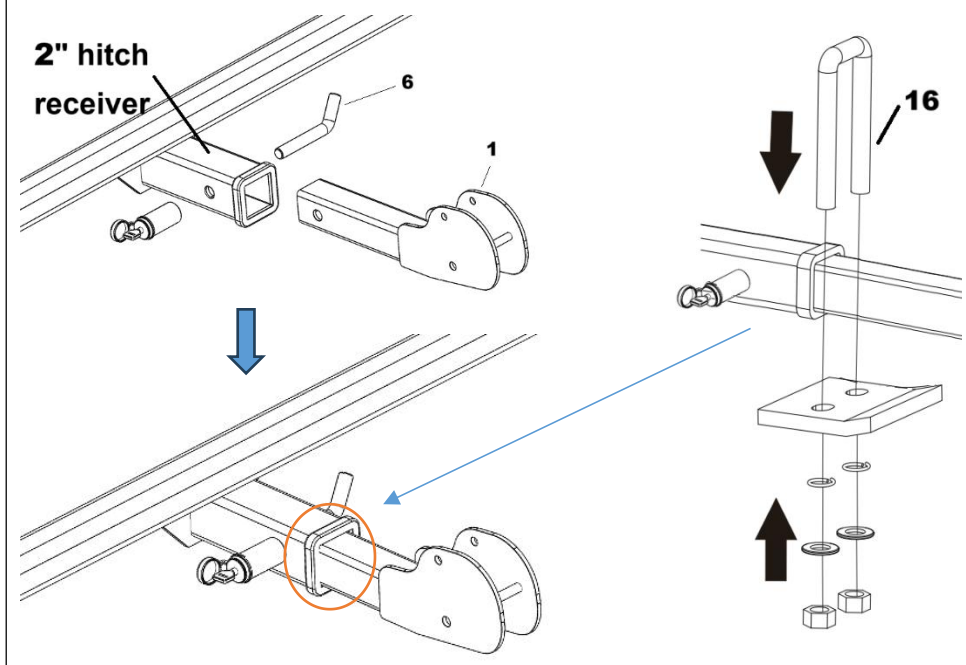

Krok 2 Zamontuj dolny słupek (2) na belce zaczepowej (1) za pomocą śrub częściowych.

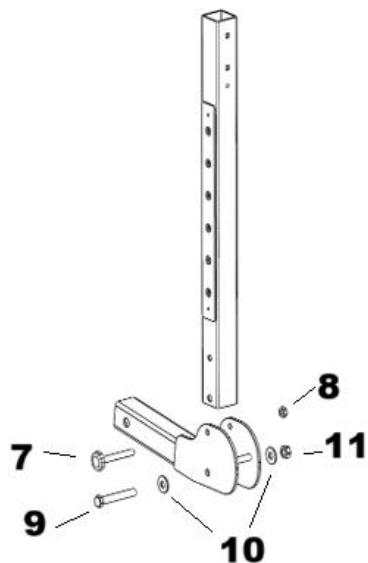

Krok 3 Złóż górny słupek (3) do dolnego słupka (2) za pomocą śrub i nakrętek .

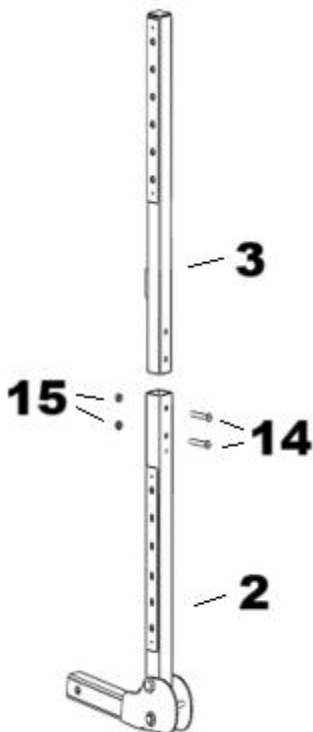

Krok 4 Zamontuj górny bagażnik na górnym słupku za pomocą części 12 i 13 , a następnie zamontuj dolny bagażnik na dolnym słupku na odpowiedniej wysokości.

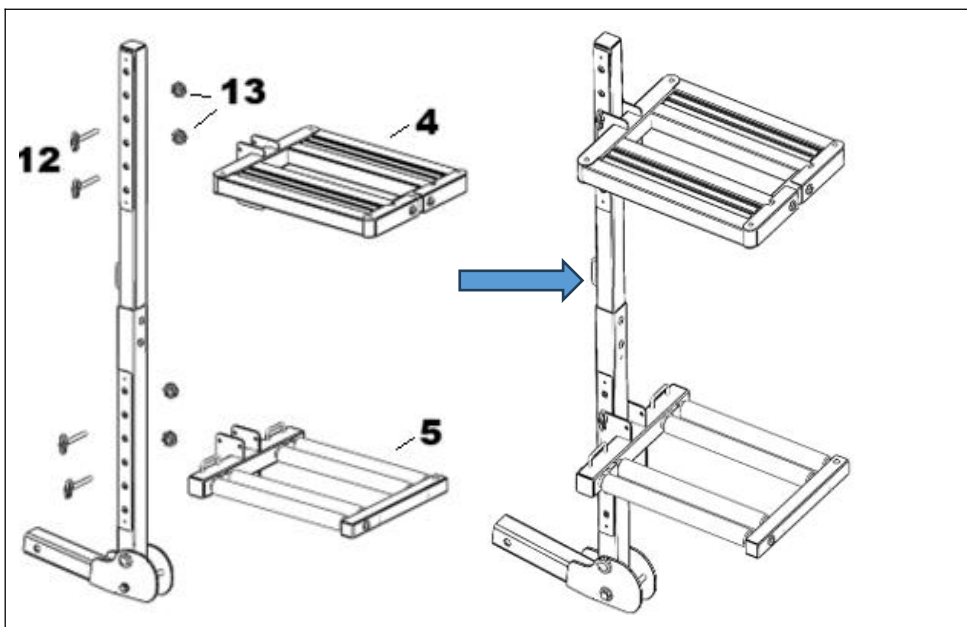

Krok 5 Otwórz 3 zamki i włóż narty lub deski snowboardowe (6 par nart/4 deski snowboardowe/2 deski snowboardowe + 3 pary nart) . Rozłóż równomiernie ciężar na bagażniku i nie przeciążaj go .

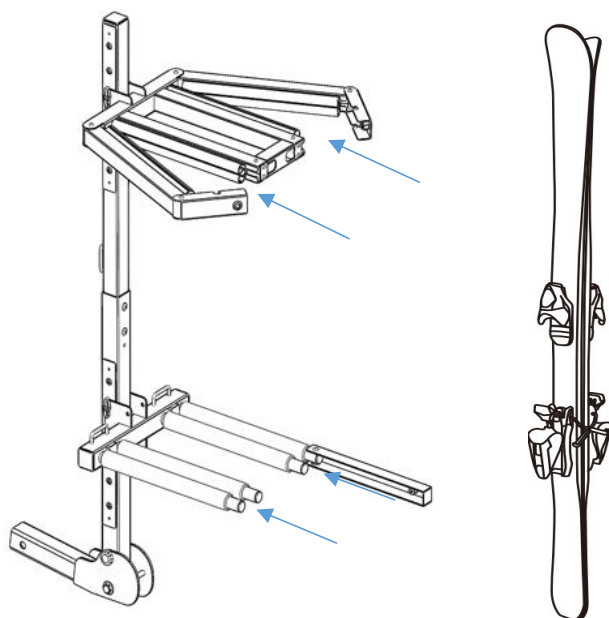

Następnie zamknij stojak, upewnij się, że jest zamknięty i sprawdź zamek przed każdym użyciem .

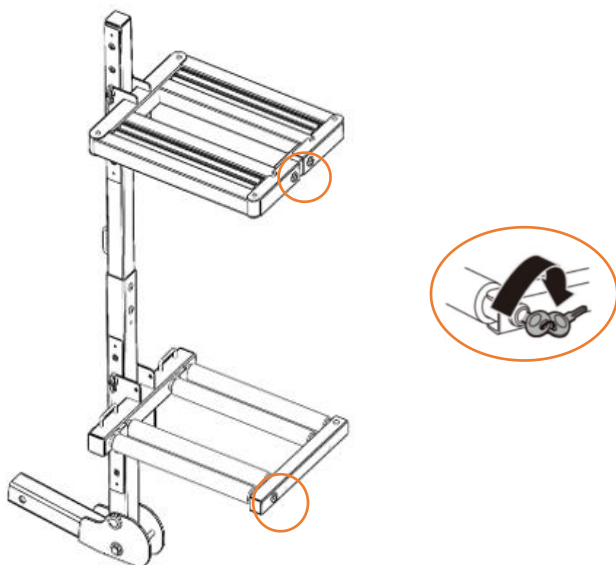

Krok 6 Załóż 4 ochraniacze na pasek , przełóż je przez haczyk, dostosuj położenie ochraniacza i zabezpiecz 3 paski, jak pokazano poniżej .

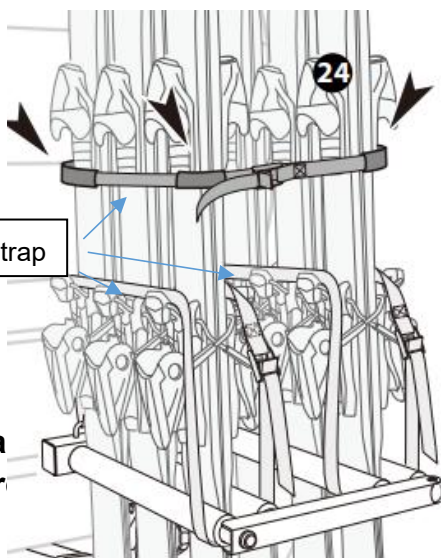
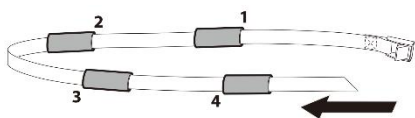

Z

Stoja
powr

Krok 7 Sprawdź jeszcze raz i upewnij się, że wysokość górnego i dolnego bagażnika jest odpowiednia do snowboardu i że bagażnik znajduje się wysoko od spodu snowboardu do podłogi.

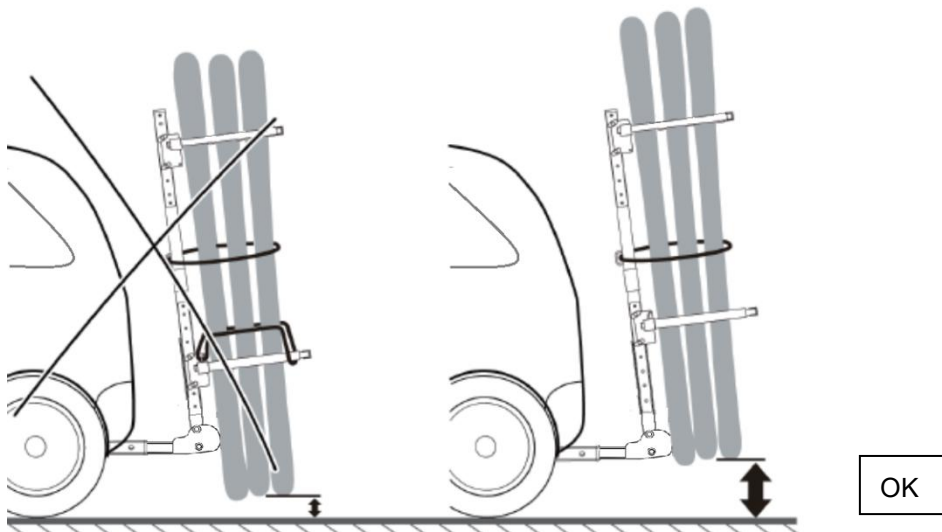

Krok 9 Odkręć śrubę T M8*80 , najpierw złóż dolną półkę, następnie odkręć śrubę T M8*80 i złóż górną półkę jako drugą. Gdy nie jest używana , zabezpiecz ją śrubą T M8*80 .

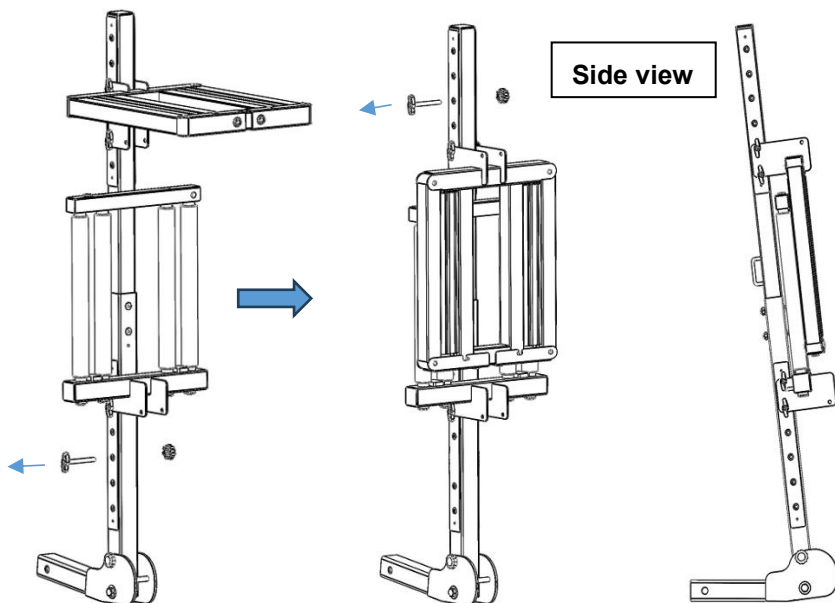

Krok 10 Zdejmij szybkozłączkę M10*80 i przechyl bagażnik, następnie możesz otworzyć tylne drzwi samochodu i wyjąć bagaż.

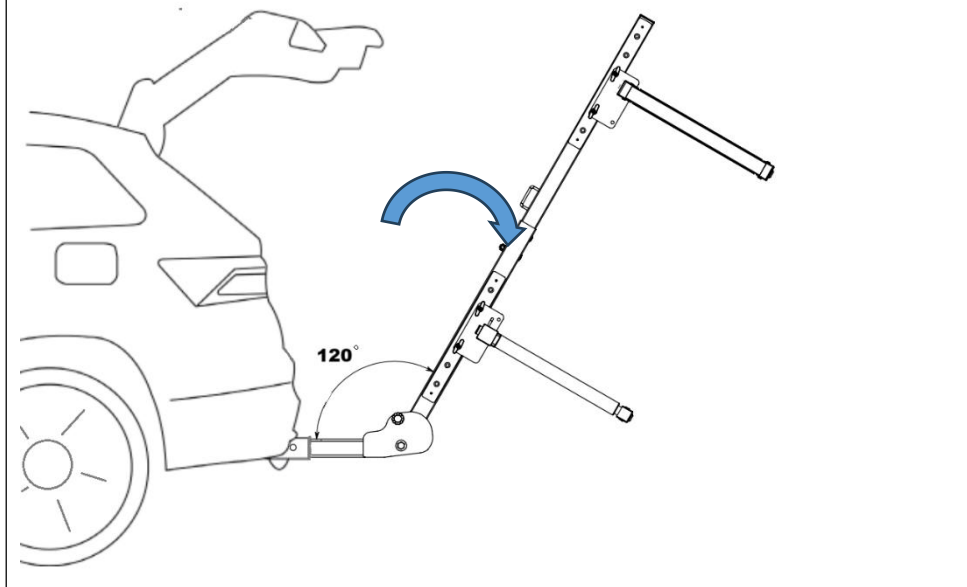

Producent: Shanghai muxin muyeyouxiangongsi

Adres: Shuangchenglu 803nong11hao1602A-1609shi, baoshanqu, szanghaj 200000 CN.

Importowane do Australii: SIHAO PTY LTD. 1 ROKEVA STREET EASTWOOD NSW 2122 Australia

Importowane do USA: Sanven Technology Ltd. Suite 250, 9166 Anaheim Place, Rancho Cucamonga, CA 91730



YH CONSULTING LIMITED.

C/O YH Consulting Limited Office 147, Centurion House, London Road, Staines-upon-Thames, Surrey, TW18 4AX



E-CrossStu GmbH
Mainzer Landstr.69,
60329 Frankfurt am Main.



VEVOR

Affordable. Reliable. Home Improvement.

SNOWBOARD DAKDRAGER

MODEL : RN-2101

VEVOR

Affordable. Reliable. Home Improvement.

SNOWBOARD ROOF RACK

MODEL: RN-2101

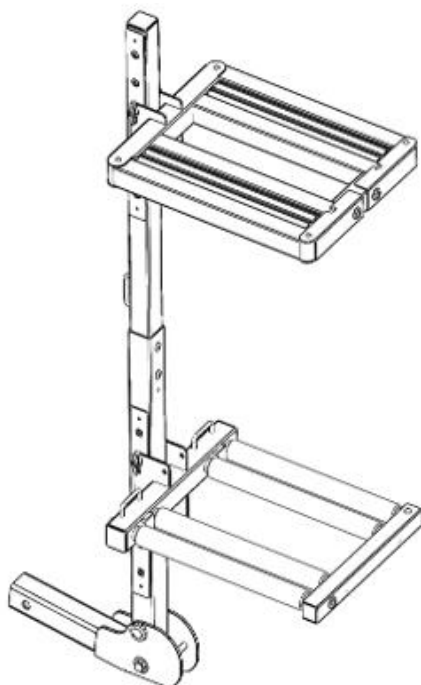

Dit is de originele handleiding. Lees alle instructies zorgvuldig door voordat u het product gebruikt. VEVOR behoudt zich het recht voor om de gebruiksaanwijzing duidelijk te interpreteren. Het uiterlijk van het product is afhankelijk van het product dat u hebt ontvangen. Neemt u het ons niet kwalijk dat we u niet meer op de hoogte stellen van eventuele technologische of software-updates voor ons product.



Waarschuwing: om het risico op letsel te verminderen, moet de gebruiker de gebruiksaanwijzing zorgvuldig lezen.

WAARSCHUWING:

LEES EN BEGRIJP ALLE VEILIGHEIDSREGELS VOORDAT U MONTAGE EN GEBRUIK VAN DE S NOWBOARD DAKRACK.

REGELS VOOR VEILIG GEBRUIK:

55. Vervoer niet meer dan zes paar ski's of meer dan vier snowboards op de drager.
56. De ski-/snowboarddrager verhoogt de totale hoogte van het voertuig. Let op de hoogte, obstakels bij het rijden met de ski-/snowboarddrager.
57. Controleer voor en na het rijden, of na het laden van ski's of een snowboard op de drager, de veiligheidsvoorzieningen, van de dragerbevestigingen en draai ze indien nodig opnieuw vast.
58. Installeer de ski-/snowboarddrager pas nadat u de dwarsbalken op het dak hebt gemonteerd.
59. Zorg ervoor dat het dak en andere afgewerkte oppervlakken van de carrosserie niet beschadigd raken bij het monteren van de ski-/snowboarddrager.
60. Let op de ski/het snowboard voordat u de achterklep of de achterklep opent .
61. Verwijder de ski-/snowboarddragers voordat u de automatische wasstraat inrijdt.
62. Het gewicht van de lading mag het maximale gewicht van 75 kg (165 lbs) niet overschrijden.
63. Controleer voor elk gebruik de bevestigingsbouten en rijd voor de veiligheid niet harder dan 120 km/u (75 mph).

VOORZORGSMAAATREGEL



25. Vermijd plotseling starten of stoppen met de drager op het voertuig. Dit kan ervoor zorgen dat de bevestigingsmiddelen losraken.
26. Houd u aan de plaatselijke wetten en regels.
27. Controleer voor het rijden of de drager goed is vergrendeld, ongeacht of er ski's of een snowboard worden op de drager gemonteerd.
28. Gebruik de ski-/snowboarddrager niet om andere goederen dan ski's en snowboards te vervoeren.







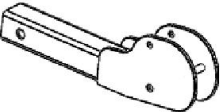

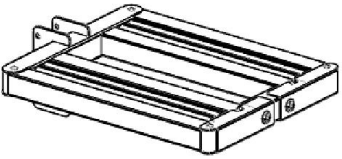

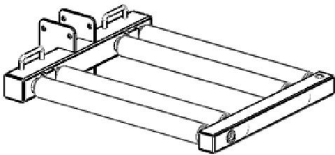
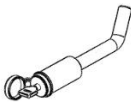

Bewaar de instructies



SPECIFICATIES

Model	RN-2101
Materiaal	Staal
Kleur	Zwart
Laadvermogen	6 Pr-ski's / 4 snowboards
Laadbreedte	400 mm * 2
Trekhaakontvanger	2"
Maximaal gewicht	75 kg

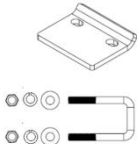
PAKKET INHOUD

Deel	Beschrijving	afbeelding	AAN TAL
1	Hitch Bar		1
2	Onderste bericht		1
3	Bovenste paal		1
4	Bovenrek		1

5	Onderste rek		1
6	Hitch Lock		1
7	M10*80 Snelbout		1
8	M10-slot Moer		1
9	M12*80 Zeskantbout		1
10	M12 ring		2
11	M12 moer		1
12	T-stijl M8*80 bouten		4
13	M8 Pruimenbloesemno ot		4
14	Wagen M8*60 bout		2
15	M8 moer		2
16	Hitch Stabilisator		1
17	Bandjes		3

18	Bandbescherming of		4
19	Sleutel		3
20	Moersleutel		1

INSTALLATIEHANDLEIDING :

Stap 1 Het monteren van de trekhaak (1) in de 2" trekhaakontvanger van de auto , vastzetten met trekhaakslot (6) Installeer vervolgens de trekhaakstabilisator (16).

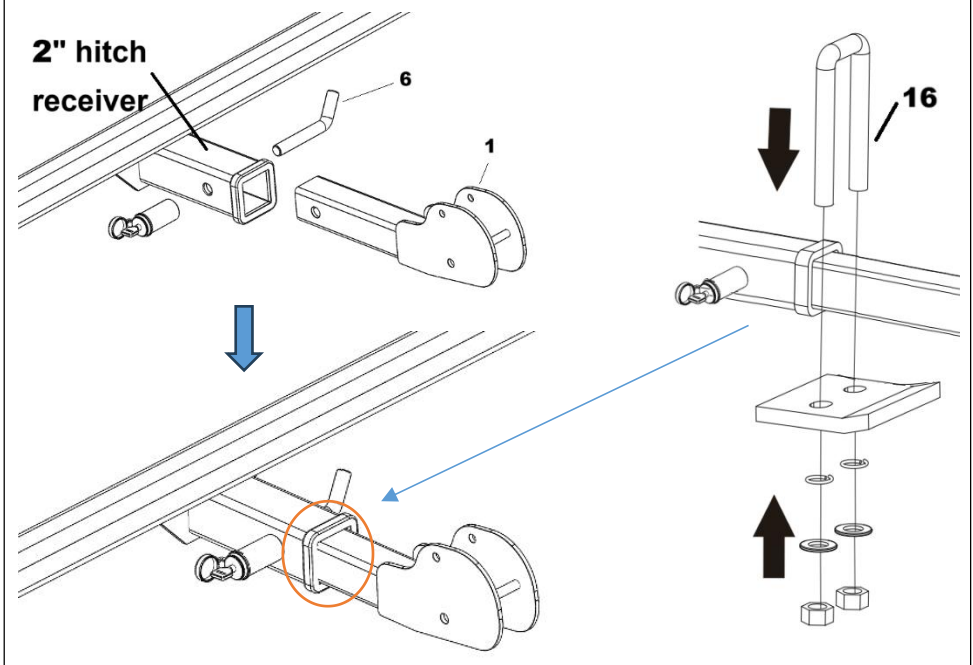

Stap 2 Monteer de onderste paal (2) op de trekstang (1) met behulp van deelbouten.

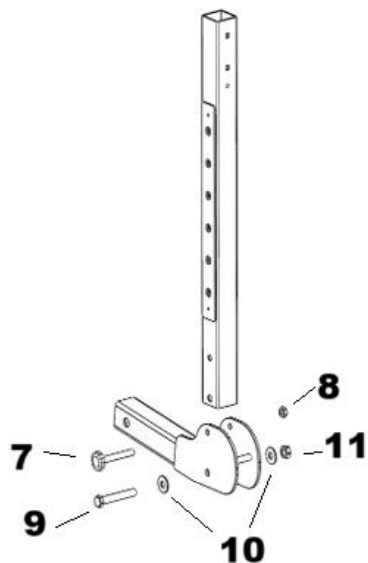

Stap 3 Monteer de bovenste paal (3) met bouten en moeren vast aan de onderste paal (2) .

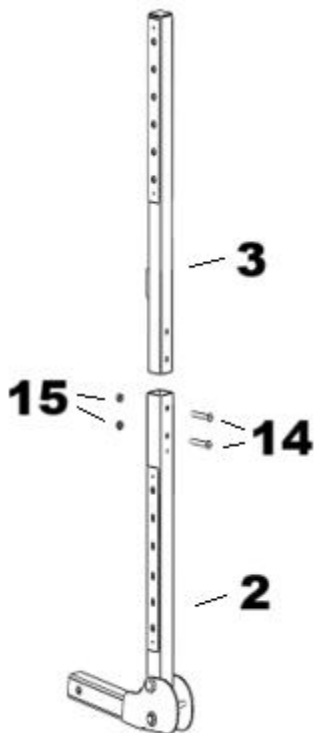

Stap 4 Monteer het bovenste rek op de bovenste paal met behulp van onderdelen 12 en 13 en monteer het onderste rek op de onderste paal op de juiste hoogte.

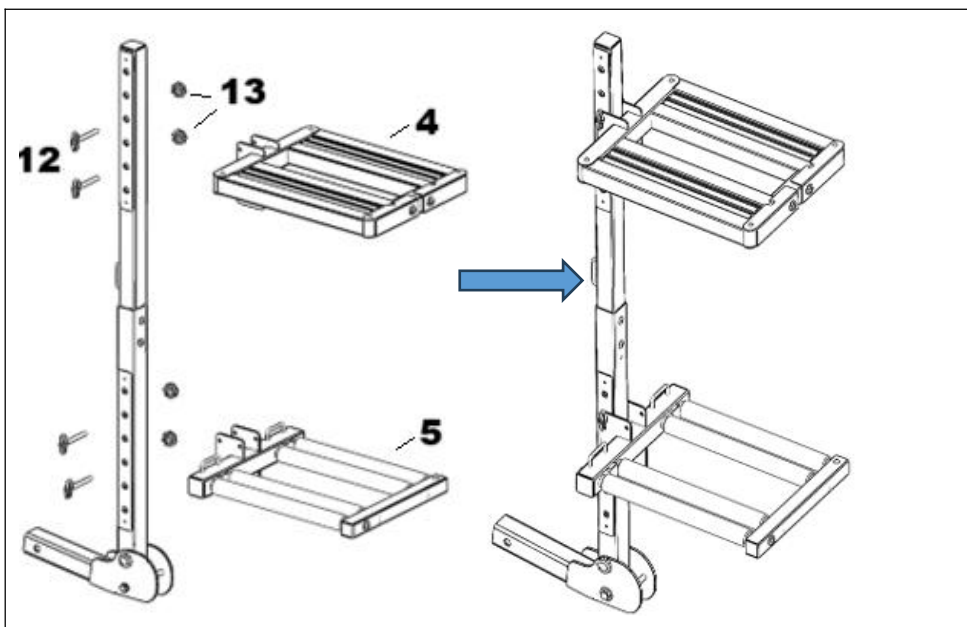

Stap 5 Open de 3 sloten en leg de ski's of snowboards (6 paar ski's/4 snowboards/2 snowboards + 3 paar ski's) erin . Verdeel de lading gelijkmatig over het rek en overbelast het niet .

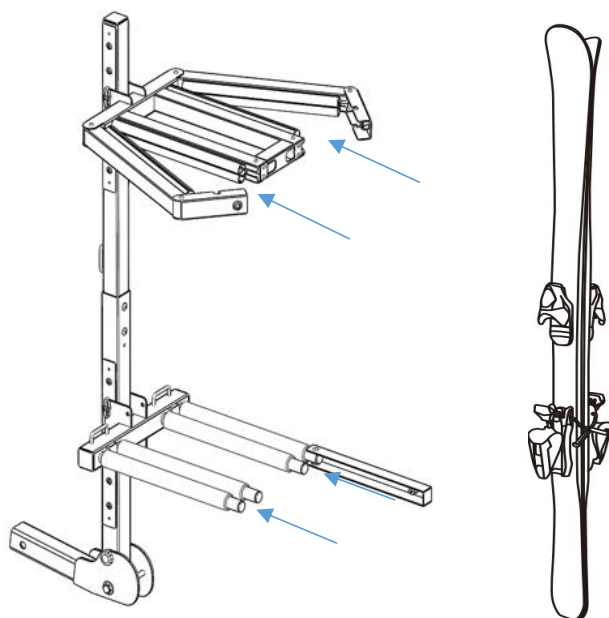

Doe het rek vervolgens op slot. Zorg ervoor dat het slot goed op slot zit en controleer het iedere keer voordat u het gebruikt .

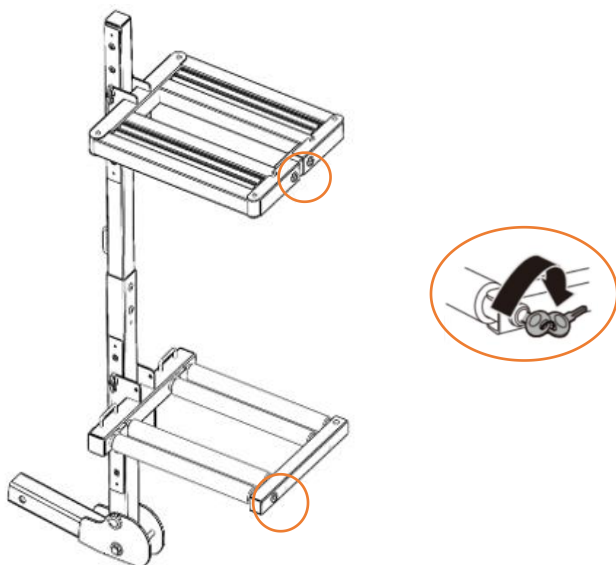

Stap 6 Plaats de 4 riembeschermers op de riem en haal ze door de haak. Pas de positie van de beschermer aan en maak de 3 riembeschermers vast zoals hieronder weergegeven .

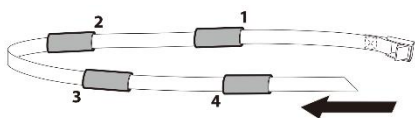

**Rek
Rug**

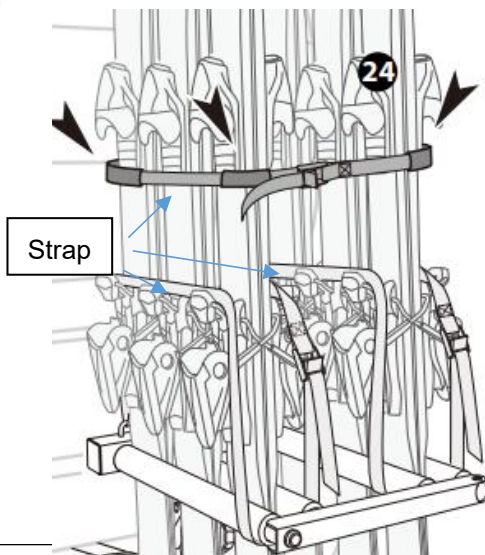

Stap 7 Controleer nogmaals of de bovenste en onderste rekken op de juiste hoogte voor het snowboard staan. Zorg dat de hoogte van de onderkant van het snowboard tot aan de vloer hoog is.

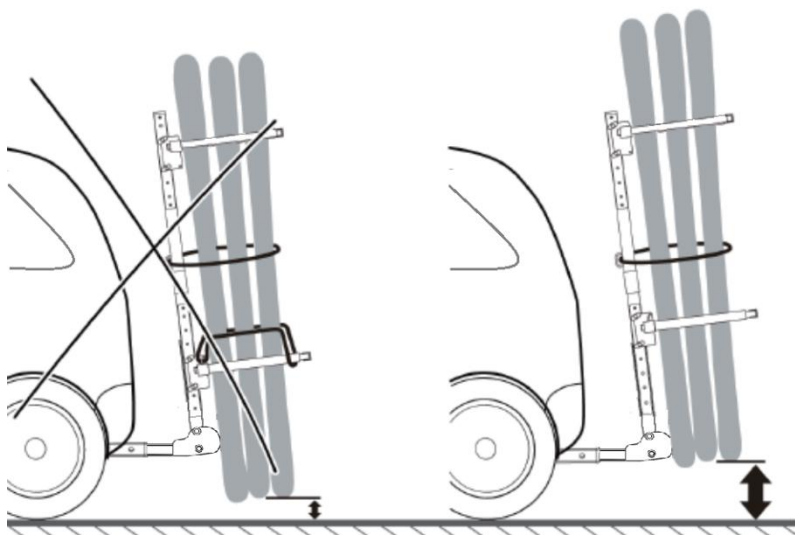

Stap 9 Verwijder de T-bout M8*80 , vouw eerst het onderste rek om, verwijder vervolgens de T-bout M8*80 en vouw vervolgens het bovenste rek om en bevestig het met de T-bout M8*80 wanneer het rek niet in gebruik is.

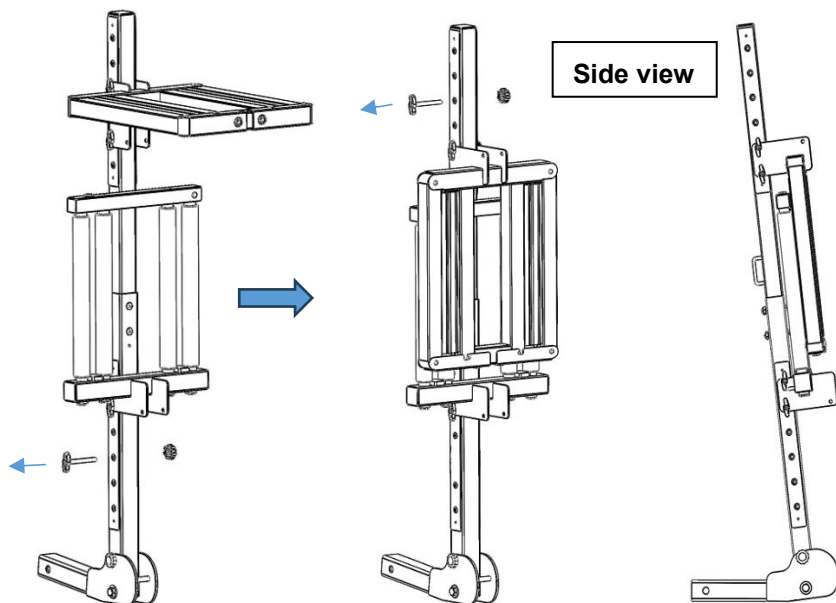

Stap 10 Verwijder de M10*80 snelkoppeling en kantel de trekhaakdrager. Vervolgens kunt u de achterdeur van de auto openen en de bagage eruit halen.

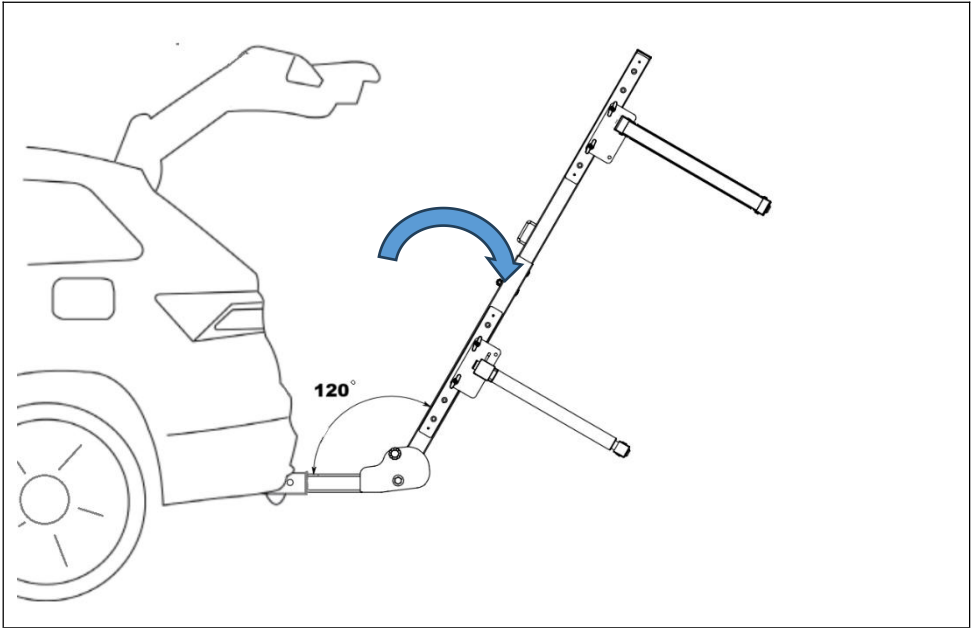

Fabrikant: Shanghaimuxinmuyeyouxiangongsi

Adres: Shuangchenglu 803nong11hao1602A-1609shi, baoshanqu, shanghai 200000 CN.

Geïmporteerd naar AUS: SIHAO PTY LTD. 1 ROKEVA STREETEASTWOOD NSW 2122 Australië

Geïmporteerd naar de VS: Sanven Technology Ltd. Suite 250, 9166 Anaheim Place, Rancho Cucamonga, CA 91730

UK	REP
-----------	------------

YH CONSULTING LIMITED.

C/O YH Consulting Limited Office 147, Centurion House, London Road, Staines-upon-Thames, Surrey, TW18 4AX

EC	REP
-----------	------------

E-CrossStu GmbH

Mainzer Landstr.69,
60329 Frankfurt am Main.



VEVOR

Affordable. Reliable. Home Improvement.

SNOWBOARD TAKRÄCKE

MODELL : RN-2101

VEVOR

Affordable. Reliable. Home Improvement.

SNOWBOARD ROOF RACK

MODELL: RN-2101

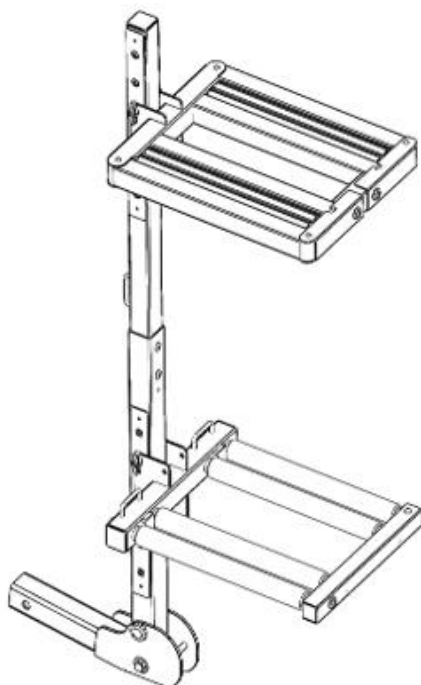

Detta är originalinstruktionerna, vänligen läs alla instruktioner noggrant innan du använder produkten. VEVOR förbehåller sig en tydlig tolkning av vår användarmanual. Produktens utseende ska vara beroende av den produkt du mottagit. Vi ber om ursäkt för att vi inte kommer att informera dig igen om det finns några teknik- eller programuppdateringar för vår produkt.



Varning – För att minska risken för skador måste användaren läsa instruktionsmanualen noggrant.

VARNING:

LÄS OCH FÖRSTÅ ALLA SÄKERHETSREGLER INNAN MONTERING OCH ANVÄNDNING AV TAKRÄCKET S NOWBOARD.

REGLER FÖR SÄKER ANVÄNDNING:

64. Bär inte mer än sex par skidor eller mer än fyra snowboards på hållaren.
65. Skid-/snowboardhållaren höjer fordonets totalhöjd. Var uppmärksam på överliggande hinder vid körning med skid-/snowboardhållaren.
66. Kontrollera säkerhetsåtgärderna före och efter körning, eller efter att du lastat skidor eller snowboard på hållaren. av bärarens fästen och dra åt dem vid behov.
67. Montera skid-/snowboardhållaren efter att du har monterat tvärbalkarna på taket.
68. Skada inte taket och andra ytor på karossen när du monterar skid-/snowboardhållaren.
69. Lägg märke till skidan/snowboarden innan du öppnar bakluckan eller halvkombiet.
70. Ta bort skid-/snowboardhållarna innan du kör in i automatiska biltvättar.
71. Lastens vikt får inte överstiga den maximala viktgränsen på 75 kg.
72. Kontrollera monteringsbultarna före varje användning och kör under 120 km/h (75 mph) för säkerhets skull.

FÖRSIKTIGHETSÅTGÄRD



29. Undvik plötsliga starter eller stopp med hållaren på fordonet. Det kan orsaka att fästena lossnar.
30. Följ lokala lagar och förordningar.
31. Kontrollera innan du kör att hållaren är ordentligt låst, oavsett om det finns skidor eller en snowboarden är monterade på hållaren.
32. Använd inte skid-/snowboardhållaren för att transportera annat än skidor och snowboard.







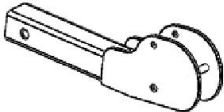

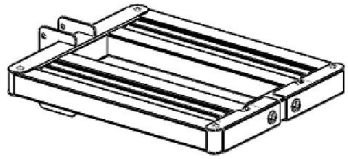

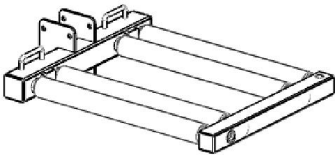
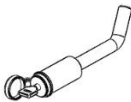
Spara instruktionerna



SPECIFIKATIONER

Modell	RN-2101
Material	Stål
Färg	Svart
Lastkapacitet	6 Pr-skidor / 4 snowboards
Lastbredd	400 mm * 2
Dragkroksmottagare	2"
Maxvikt	75 kg

PAKET INNEHÅLL

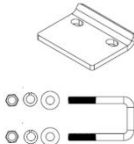
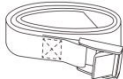
Del	Beskrivning	bild	ANTAL
1	Häckstång		1
2	Bottenstolpe		1
3	Toppinlägg		1
4	Topprack		1

5	Nedersta korgen		1
6	Häklås		1
7	M10*80 snabbult		1
8	M10-lås Mutter		1
9	M12*80 sexkantsbult		1
10	M12 Bricka		2
11	M12-mutter		1
12	T-formade M8*80-bultar		4
13	M8 Plommonbloms Mutter		4
14	Vagn M8*60 Bult		2
15	M8-mutter		2
16	Hick -stabilisator		1
17	Remmar		3

18	Remskydd eller		4
19	Nyckel		3
20	Skiftnyckel		1

INSTALLATIONSGUIDE :

Steg 1 Montera dragkroken (1) in i bilens 2-tums dragkroksfäste , säkra med dragkrokslås (6). Montera sedan dragkroksstabilisatorn (16).

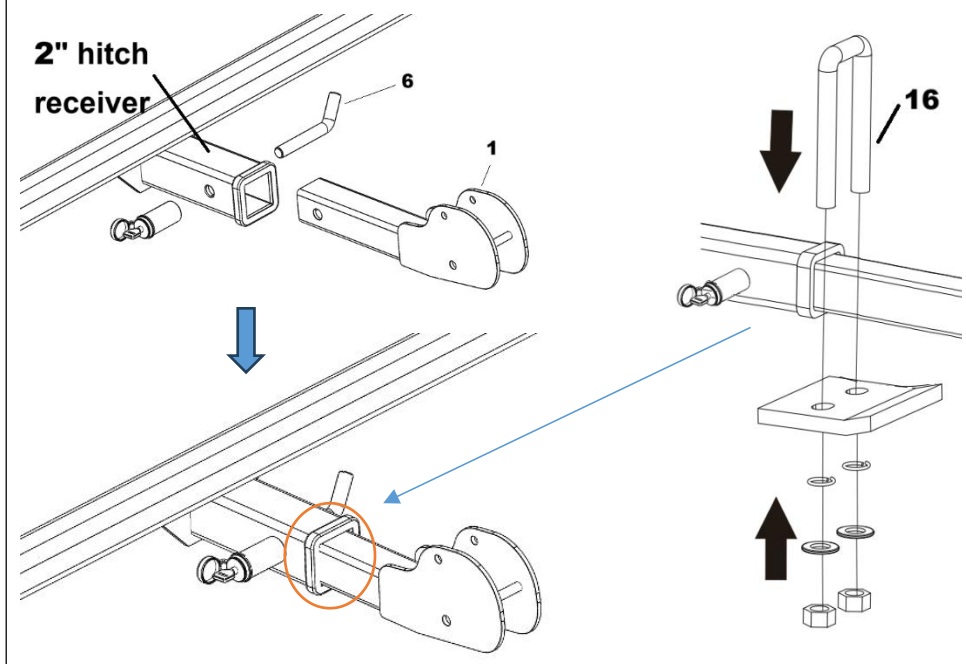

Steg 2 Montera den nedre stolpen (2) på dragkroken (1) med delbultar.

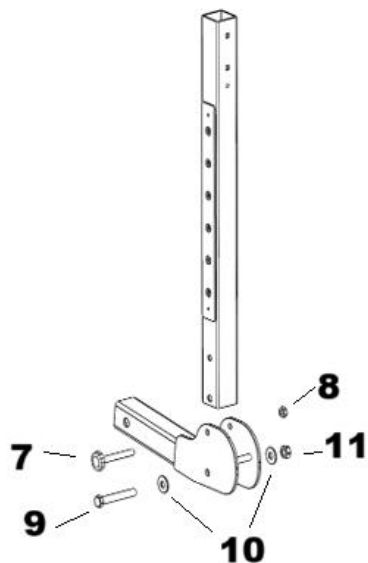

Steg 3 Montera den övre stolpen (3) i den nedre stolpen (2) med bultar och muttrar .

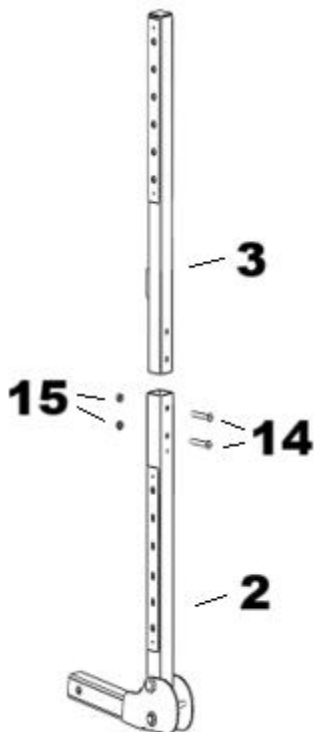

Steg 4 Montera det översta gallret på den översta stolpen med hjälp av delarna 12 och 13 , och montera sedan det nedre gallret på den nedre stolpen på lämplig höjd.

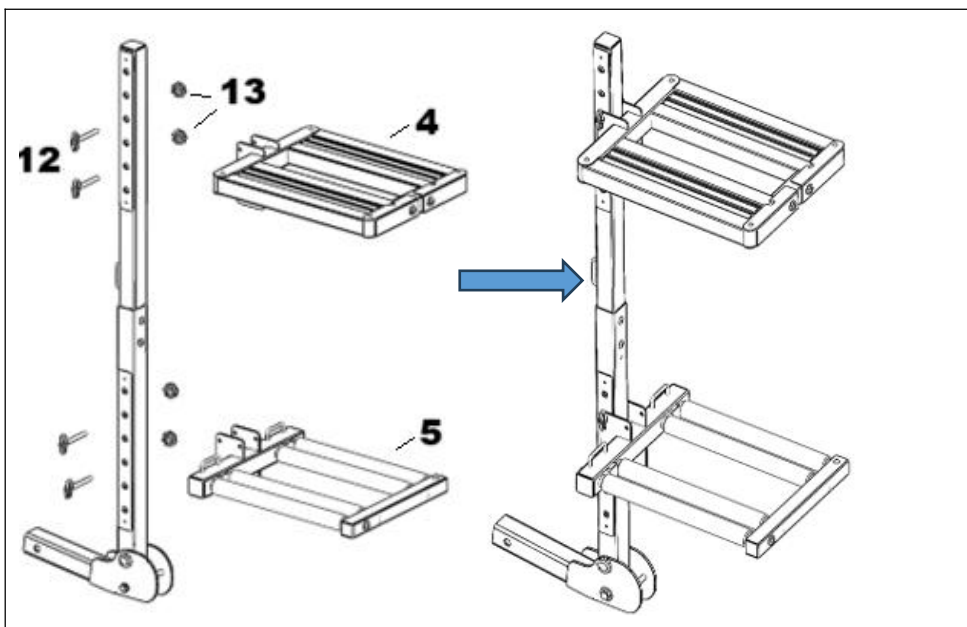

Steg 5 Öppna de 3 låsen, sätt i skidorna eller snowboardarna (6 par skidor/4 snowboardar/2 snowboardar + 3 par skidor) . Fördela lasten jämnt över pakethållaren och överbelasta inte .

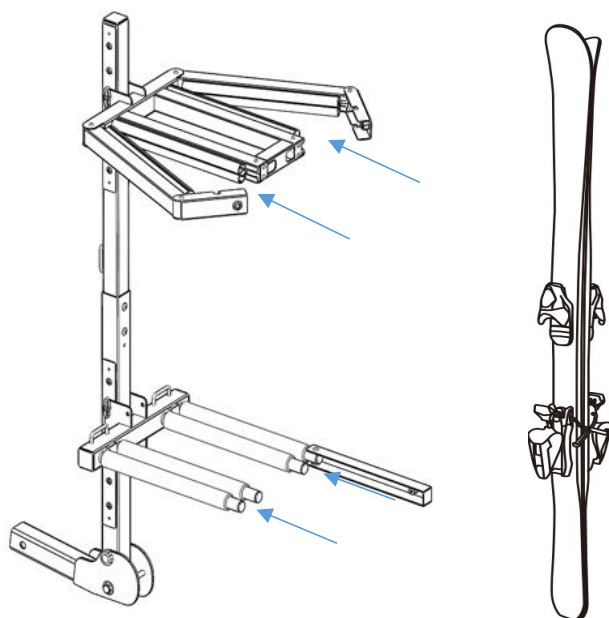

Lås sedan stället, och se till att låsa det, och kontrollera låset varje gång innan du använder det.

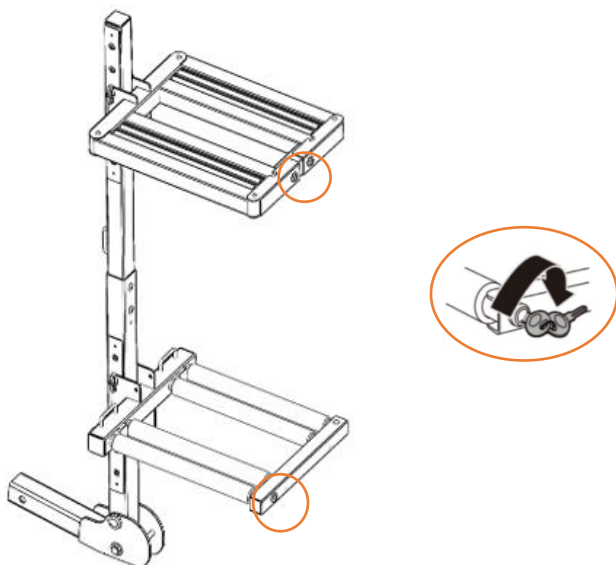

Steg 6 Placera de 4 st remskydden på remmen och trä dem genom kroken. Justera skyddets position och fäst de 3 st remmarna enligt nedan .

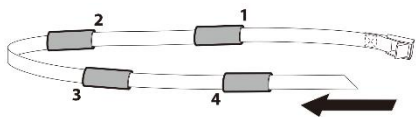

**Kugg
Tillba**

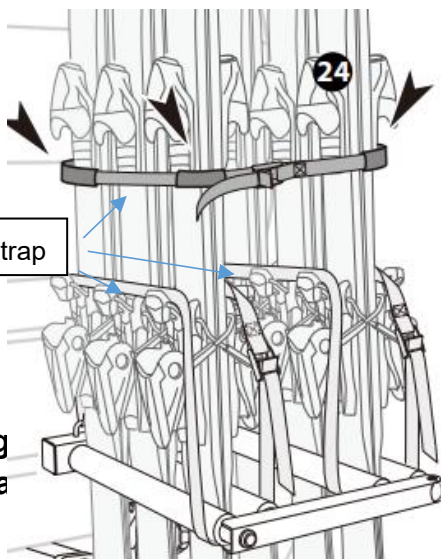

Steg 7 Inspektera igen och se till att det övre och nedre ställets höjd är lämplig för snowboarden, håll dem höga från snowboardens botten till golvet.

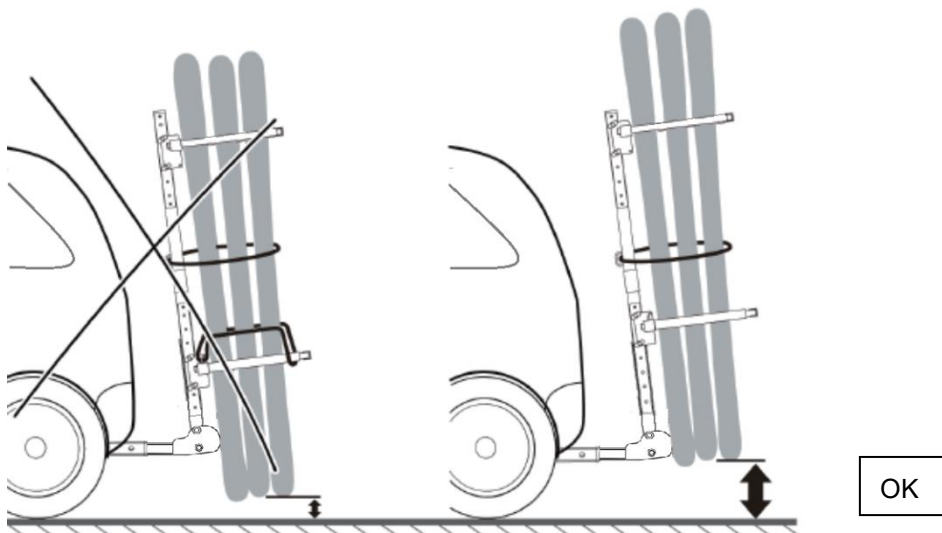

Steg 9 Ta bort T-bulten M8*80 , vik först det nedre gallret, ta sedan bort T-bulten M8*80 och vik upp gallret en sekund senare. Fäst den med T-bulten M8*80 när den inte används .

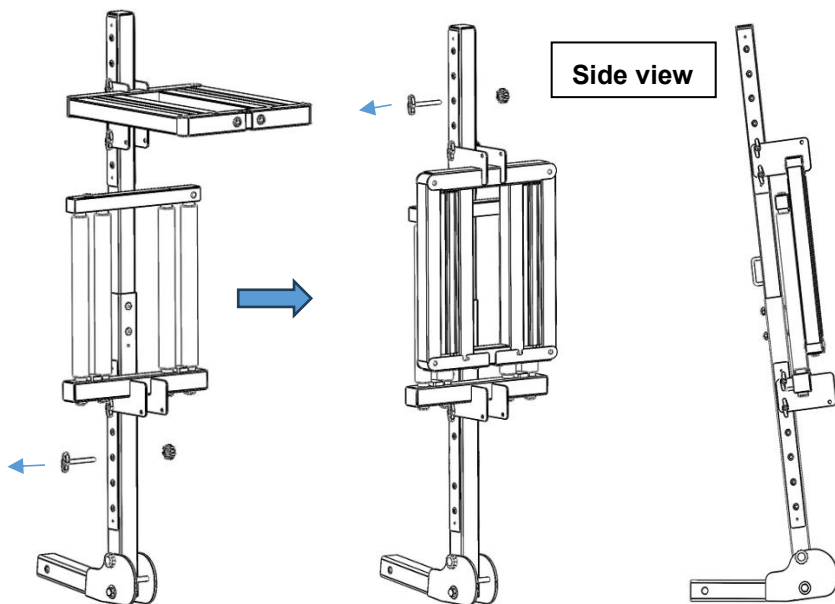

Steg 10 Ta bort M10*80-snabbskruven och luta dragkroksstället, då kan du öppna bilens baddörr och hämta bagaget.

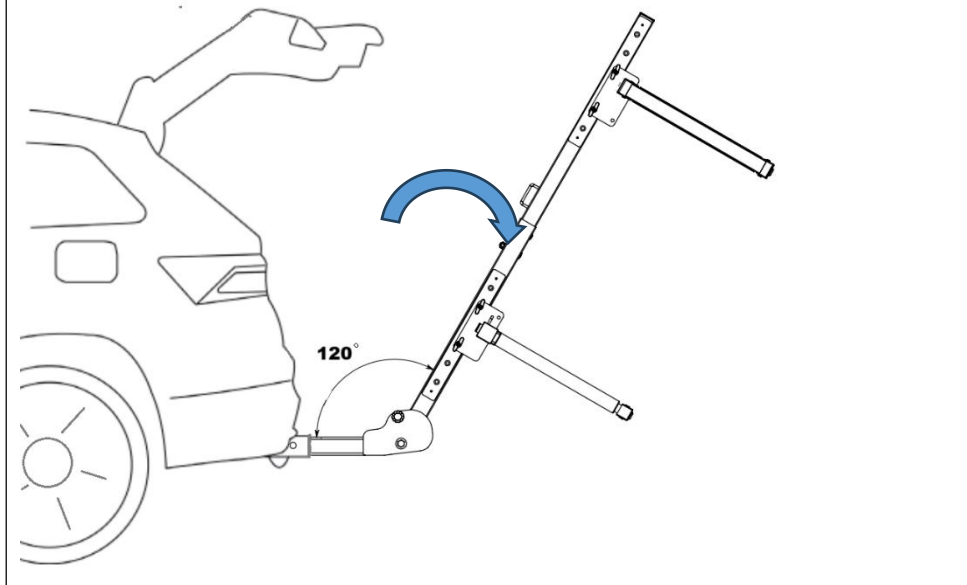

Tillverkare: Shanghaimuxinmuyeyouxiangongsi

Adress: Shuangchenglu 803nong11hao1602A-1609shi, baoshanqu, shanghai 200000 CN.

Importerad till Australien: SIHAO PTY LTD. 1 ROKEVA STREETEASTWOOD NSW 2122 Australien

Importerad till USA: Sanven Technology Ltd. Suite 250, 9166 Anaheim Place, Rancho Cucamonga, CA 91730



YH CONSULTING LIMITED.

C/O YH Consulting Limited Office 147, Centurion House, London Road, Staines-upon-Thames, Surrey, TW18 4AX



E-CrossStu GmbH
Mainzer Landstr.69,
60329 Frankfurt am Main.

